



MEASUREMENT REPORT

FCC PART 15.407 / RSS-247 WLAN 802.11a

FCC ID: 2ACS5-ST16P
IC: 11554B-ST16P
APPLICANT: Yuneec Technology Co., Limited

Application Type: Certification
Product: Personal Ground Station
FCC Model No.: ST16***** (The "*" can be 0 to 9, a to z, A to Z, blank or plus, for marketing purpose.)
IC Model No.: ST16 Pro
Brand Name: YUNEEC
FCC Classification: Unlicensed National Information Infrastructure (UNII)
FCC Rule Part(s): Part 15.407
IC Rule(s): RSS-247 Issue 1, RSS-GEN Issue 4
Test Procedure(s): ANSI C63.10-2013, KDB 789033 D02v01r02
Test Date: January 22 ~ July 20, 2016

Reviewed By
Manager :

Robin Wu

(Robin Wu)

Approved By
CEO :

Marlin Chen

(Marlin Chen)



The test results relate only to the samples tested.

This equipment has been shown to be capable of compliance with the applicable technical standards as indicated in the measurement report and was tested in accordance with the measurement procedures specified in KDB 789033 D02v01r02. Test results reported herein relate only to the item(s) tested.

The test report shall not be reproduced except in full without the written approval of MRT Technology (Suzhou) Co., Ltd.

Revision History

Report No.	Version	Description	Issue Date	Note
1607RSU01403	Rev. 01	Initial report	07-25-2016	Invalid
1607RSU01403	Rev. 02	Add the original 5GHz antenna	08-11-2016	Valid

Compare the original EUT (FCC ID: 2ACS5-ST16)	
RF Parts	Modification
ZigBee	Add the shielding case and change the antenna
WLAN (2.4GHz)	No change
WLAN (5GHz)	Add one antenna
Note 1: Besides the difference as above, add one new adapter and the others are same as before. Note 2: The report was based on the original MRT report 1601RSU02003 and add the RF radiated emission and conducted emission testing.	

CONTENTS

Description	Page
§2.1033 General Information	5
1. INTRODUCTION	6
1.1. Scope	6
1.2. MRT Test Location	6
2. PRODUCT INFORMATION	7
2.1. Equipment Description.....	7
2.2. Product Specification Subjective to this Report.....	7
2.3. Working Frequencies for this report	7
2.4. Description of Available Antennas.....	7
2.5. Description of Antenna RF Port	8
2.6. Test Mode	8
2.7. Test Software	8
2.8. Device Capabilities	9
2.9. Test Configuration	9
2.10. EMI Suppression Device(s)/Modifications.....	9
2.11. Labeling Requirements.....	9
3. DESCRIPTION OF TEST	10
3.1. Evaluation Procedure	10
3.2. AC Line Conducted Emissions	10
3.3. Radiated Emissions	11
4. ANTENNA REQUIREMENTS.....	12
5. TEST EQUIPMENT CALIBRATION DATE.....	13
6. MEASUREMENT UNCERTAINTY.....	15
7. TEST RESULT	16
7.1. Summary	16
7.2. 26dB Bandwidth Measurement.....	18
7.2.1. Test Limit	18
7.2.2. Test Procedure used.....	18
7.2.3. Test Setting.....	18
7.2.4. Test Setup	18
7.2.5. Test Result.....	19
7.3. 6dB Bandwidth Measurement.....	20
7.3.1. Test Limit	20

7.3.2. Test Procedure used.....	20
7.3.3. Test Setting.....	20
7.3.4. Test Setup	20
7.3.5. Test Result.....	21
7.4. Output Power Measurement.....	22
7.4.1. Test Limit	22
7.4.2. Test Procedure Used	22
7.4.3. Test Setting.....	22
7.4.4. Test Setup	22
7.4.5. Test Result.....	23
7.5. Power Spectral Density Measurement	24
7.5.1. Test Limit	24
7.5.2. Test Procedure Used	24
7.5.3. Test Setting.....	24
7.5.4. Test Setup	25
7.5.5. Test Result.....	26
7.6. Frequency Stability Measurement.....	27
7.6.1. Test Limit	27
7.6.2. Test Procedure Used	27
7.6.3. Test Setup	27
7.6.4. Test Result.....	28
7.7. Radiated Spurious Emission Measurement	29
7.7.1. Test Limit	29
7.7.2. Test Procedure Used	29
7.7.3. Test Setting.....	29
7.7.4. Test Setup	30
7.7.5. Test Result.....	32
7.8. Radiated Restricted Band Edge Measurement	41
7.8.1. Test Limit	41
7.8.2. Test Result of Radiated Restricted Band Edge	44
7.9. AC Conducted Emissions Measurement.....	56
7.9.1. Test Limit	56
7.9.2. Test Setup	56
7.9.3. Test Result.....	57
8. CONCLUSION.....	59

§2.1033 General Information

Applicant:	Yunee Technology Co., Limited
Applicant Address:	2/F Man Shung Industrial Building, 7 Lai Yip Street, Kwun Tong, Hong Kong
Manufacturer:	Yunee International (China) Co., Ltd.
Manufacturer Address:	No.388 East Zhengwei Road, Jinxi Town, Kunshan, Jiangsu 215324, China
Test Site:	MRT Technology (Suzhou) Co., Ltd
Test Site Address:	D8 Building, Youxin Industrial Park, No.2 Tian'edang Rd., Wuzhong Economic Development Zone, Suzhou, China
FCC Registration No.:	809388
IC Registration No.:	11384A
FCC Rule Part(s):	Part 15.407
IC Rule(s):	RSS-247 Issue 1, RSS-GEN Issue 4
Test Device Serial No.:	N/A <input type="checkbox"/> Production <input checked="" type="checkbox"/> Pre-Production <input type="checkbox"/> Engineering
FCC Classification:	Unlicensed National Information Infrastructure (UNII)

Test Facility / Accreditations

Measurements were performed at MRT Laboratory located in Tian'edang Rd., Suzhou, China.

- MRT facility is a FCC registered (MRT Reg. No. 809388) test facility with the site description report on file and has met all the requirements specified in Section 2.948 of the FCC Rules.
- MRT facility is an IC registered (MRT Reg. No. 11384A-1) test laboratory with the site description on file at Industry Canada.
- MRT facility is a VCCI registered (R-4179, G-814, C-4664, T-2206) test laboratory with the site description on file at VCCI Council.
- MRT Lab is accredited to ISO 17025 by the American Association for Laboratory Accreditation (A2LA) under the American Association for Laboratory Accreditation Program (A2LA Cert. No. 3628.01) in EMC, Telecommunications and Radio testing for FCC, Industry Canada, EU and TELEC Rules.



1. INTRODUCTION

1.1. Scope

Measurement and determination of electromagnetic emissions (EMC) of radio frequency devices including intentional and/or unintentional radiators for compliance with the technical rules and regulations of the Federal Communications Commission and the Industry Canada Certification and Engineering Bureau.

1.2. MRT Test Location

The map below shows the location of the MRT LABORATORY, its proximity to the Taihu Lake. These measurement tests were conducted at the MRT Technology (Suzhou) Co., Ltd. Facility located at D8 Building, Youxin Industrial Park, No.2 Tian'edang Rd., Wuzhong Economic Development Zone, Suzhou, China. The detailed description of the measurement facility was found to be in compliance with the requirements of § 2.948 according to ANSI C63.4-2009 on September 30, 2013.



2. PRODUCT INFORMATION

2.1. Equipment Description

Product Name	Personal Ground Station
FCC Model No.	ST16***** (The "*" can be 0 to 9, a to z, A to Z, blank or plus, for marketing purpose.)
IC Model No.	ST16 Pro
Brand Name	YUNEEC
WLAN Specification	802.11a/b/g/n
ZigBee Specification	802.15.4
Component	
Adapter	M/N: A31-501000 INPUT: 100-240V ~ 50/60Hz, 0.2A OUTPUT: 5Vdc, 1000mA

2.2. Product Specification Subjective to this Report

Frequency Range	802.11a: 5745~5825MHz
Maximum Average Output Power	802.11a: 21.55dBm
Type of Modulation	802.11a: OFDM

Note: For other features of this EUT, test report will be issued separately.

2.3. Working Frequencies for this report

Channel	Frequency	Channel	Frequency	Channel	Frequency
149	5745 MHz	153	5765 MHz	157	5785 MHz
161	5805 MHz	165	5825 MHz	--	--

2.4. Description of Available Antennas

Antenna Type	Manufacturer	Frequency Band (GHz)	Max Peak Gain (dBi)
Directional Antenna	Cortec Technology Inc.	5	1.50
Omni-directional Antenna	Yuneeec Technology Co., Limited	5	-3.48

2.5. Description of Antenna RF Port

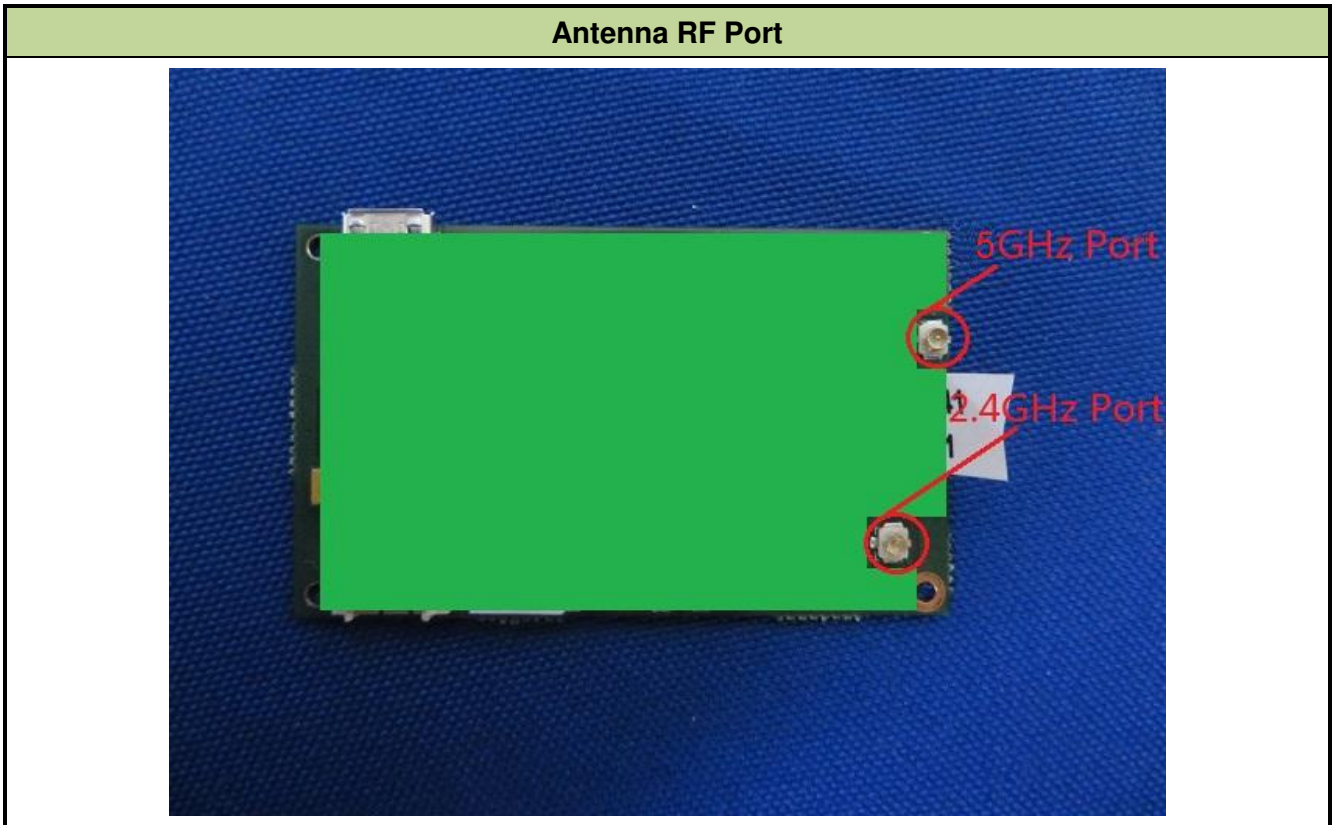

2.6. Test Mode

Test Mode	Mode 1: Transmit by 802.11a
-----------	-----------------------------

2.7. Test Software

The test utility software used during testing was “adb.exe”.

2.8. Device Capabilities

This device contains the following capabilities:

2.4GHz WLAN (DTS) & 2.4GHz ZigBee (DTS) & 5.8GHz WLAN (UNII)

Note: 5GHz (UNII) operation is possible in 20MHz channel bandwidths. The maximum achievable duty cycle was determined based on measurements performed on a spectrum analyzer in zero-span mode with RBW = 8MHz, VBW = 50MHz, and detector = average per the guidance of Section B)2)b) of KDB 789033 D02v01r02. The RBW and VBW were both greater than 50/T, where T is the minimum transmission duration, and the number of sweep points across T was greater than 100.

The duty cycles are as follows:

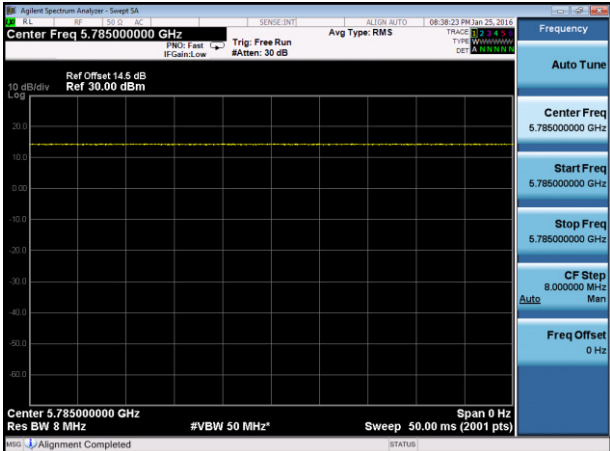
Test Mode	Duty Cycle
802.11a	100 %
	

2.9. Test Configuration

The **Personal Ground Station FCC ID: 2ACS5-ST16P** was tested per the guidance of KDB 789033 D02v01r02. ANSI C63.10-2013 was used to reference the appropriate EUT setup for radiated spurious emissions testing and AC line conducted testing.

2.10. EMI Suppression Device(s)/Modifications

No EMI suppression device(s) were added and/or no modifications were made during testing.

2.11. Labeling Requirements

Per 2.1074 & 15.19; Docket 95-19

The label shall be permanently affixed at a conspicuous location on the device; instruction manual or pamphlet supplied to the user and be readily visible to the purchaser at the time of purchase.

However, when the device is so small wherein placement of the label with specified statement is not practical, only the FCC ID must be displayed on the device per Section 15.19(a)(5). Please see attachment for FCC ID label and label location.

3. DESCRIPTION OF TEST

3.1. Evaluation Procedure

The measurement procedures described in the American National Standard for Testing Unlicensed Wireless Devices (ANSI C63.10-2013), and the guidance provided in KDB 789033 D02v01r02 were used in the measurement of the **Personal Ground Station FCC ID: 2ACS5-ST16P**.

Deviation from measurement procedure.....None

3.2. AC Line Conducted Emissions

The line-conducted facility is located inside an 8'x4'x4' shielded enclosure. A 1m x 2m wooden table 80cm high is placed 40cm away from the vertical wall and 80cm away from the sidewall of the shielded room. Two 10kHz-30MHz, 50Ω/50uH Line-Impedance Stabilization Networks (LISNs) are bonded to the shielded room floor. Power to the LISNs is filtered by external high-current high-insertion loss power line filters. These filters attenuate ambient signal noise from entering the measurement lines. These filters are also bonded to the shielded enclosure.

The EUT is powered from one LISN and the support equipment is powered from the second LISN. All interconnecting cables more than 1 meter were shortened to a 1 meter length by non-inductive bundling (serpentine fashion) and draped over the back edge of the test table. All cables were at least 40cm above the horizontal reference ground-plane. Power cables for support equipment were routed down to the second LISN while ensuring that that cables were not draped over the second LISN.

Sufficient time for the EUT, support equipment, and test equipment was allowed in order for them to warm up to their normal operating condition. The RF output of the LISN was connected to the receiver and exploratory measurements were made to determine the frequencies producing the maximum emission from the EUT. The receiver was scanned from 150kHz to 30MHz. The detector function was set to peak mode for exploratory measurements while the bandwidth of the analyzer was set to 9kHz. The EUT, support equipment, and interconnecting cables were arranged and manipulated to maximize each emission. Each emission was also maximized by varying: power lines, the mode of operation or data exchange speed, or support equipment whichever determined the worst-case emission. Once the worst case emissions have been identified, the one EUT cable configuration/arrangement and mode of operation that produced these emissions are used for final measurements on the same test site. The analyzer is set to CISPR quasi-peak and average detectors with a 9kHz resolution bandwidth for final measurements.

An extension cord was used to connect to a single LISN which powered by EUT. The extension cord was calibrated with LISN, the impedance and insertion loss are compliance with the requirements as stated in ANSI C63.10-2013.

Line conducted emissions test results are shown in Section 7.9.

3.3. Radiated Emissions

The radiated test facilities consisted of an indoor 3 meter semi-anechoic chamber used for final measurements and exploratory measurements, when necessary. The measurement area is contained within the semi-anechoic chamber which is shielded from any ambient interference. For measurements above 1GHz absorbers are arranged on the floor between the turn table and the antenna mast in such a way so as to maximize the reduction of reflections. For measurements below 1GHz, the absorbers are removed. A MF Model 210SS turntable is used for radiated measurement. It is a continuously rotatable, remote controlled, metallic turntable and 2 meters (6.56 ft.) in diameter. The turn table is flush with the raised floor of the chamber in order to maintain its function as a ground plane. An 80cm high PVC support structure is placed on top of the turntable.

For all measurements, the spectrum was scanned through all EUT azimuths and from 1 to 4 meter receive antenna height using a broadband antenna from 30MHz up to the upper frequency shown in 15.33(b)(1) depending on the highest frequency generated or used in the device or on which the device operates or tunes. For frequencies above 1GHz, linearly polarized double ridge horn antennas were used. For frequencies below 30MHz, a calibrated loop antenna was used. When exploratory measurements were necessary, they were performed at 1 meter test distance inside the semi-anechoic chamber using broadband antennas, broadband amplifiers, and spectrum analyzers to determine the frequencies and modes producing the maximum emissions. Sufficient time for the EUT, support equipment, and test equipment was allowed in order for them to warm up to their normal operating condition. The test set-up for frequencies below 1GHz was placed on top of the 0.8 meter high, 1 x 1.5 meter table; and test set-up for frequencies 1-40GHz was placed on top of the 1.5 meter high, 1 x 1.5 meter table. The EUT, support equipment, and interconnecting cables were arranged and manipulated to maximize each emission. Appropriate precaution was taken to ensure that all emissions from the EUT were maximized and investigated. The system configuration, clock speed, mode of operation or video resolution, if applicable, turntable azimuth, and receive antenna height was noted for each frequency found.

Final measurements were made in the semi-anechoic chamber using calibrated, linearly polarized broadband and horn antennas. The test setup was configured to the setup that produced the worst case emissions. The spectrum analyzer was set to investigate all frequencies required for testing to compare the highest radiated disturbances with respect to the specified limits. The turntable containing the EUT was rotated through 360 degrees and the height of the receive antenna was varied 1 to 4 meters and stopped at the azimuth and height producing the maximum emission. Each emission was maximized by changing the orientation of the EUT through three orthogonal planes and changing the polarity of the receive antenna, whichever produced the worst-case emissions. According to 3dB Beam-Width of horn antenna, the horn antenna should be always directed to the EUT when rising height.

4. ANTENNA REQUIREMENTS

Excerpt from §15.203 of the FCC Rules/Regulations:

“An intentional radiator antenna shall be designed to ensure that no antenna other than that furnished by the responsible party can be used with the device. The use of a permanently attached antenna or of an antenna that uses a unique coupling to the intentional radiator shall be considered sufficient to comply with the provisions of this section.”

- The antenna of **Personal Ground Station** uses a unique connector.
- There are no provisions for connection to an external antenna.

Conclusion:

The **Personal Ground Station FCC ID: 2ACS5-ST16P** unit complies with the requirement of §15.203.

5. TEST EQUIPMENT CALIBRATION DATE

Conducted Emissions - SR2

Instrument	Manufacturer	Type No.	Asset No.	Cali. Interval	Cali. Due Date
EMI Test Receiver	R&S	ESR7	MRTSUE06001	1 year	2016/11/03
Two-Line V-Network	R&S	ENV216	MRTSUE06002	1 year	2016/11/03
Two-Line V-Network	R&S	ENV216	MRTSUE06003	1 year	2016/11/03
Temperature/Humidity Meter	Yuhuaze	THC-2	MRTSUE06182	1 year	2016/12/20
Shielding Anechoic Chamber	Mikebang	Chamber-SR2	MRTSUE06215	1 year	2017/05/10

Radiated Emission - AC1

Instrument	Manufacturer	Type No.	Asset No.	Cali. Interval	Cali. Due Date
EXA Signal Analyzer	Agilent	N9010A	MRTSUE06124	1 year	2017/06/23
EMI Test Receiver	R&S	ESR7	MRTSUE06001	1 year	2016/11/03
Microwave System Amplifier	Agilent	83017A	MRTSUE06076	1 year	2017/03/29
Preamplifier	Schwarzbeck	BBV 9721	MRTSUE06121	1 year	2017/04/16
Loop Antenna	Schwarzbeck	FMZB1519	MRTSUE06025	1 year	2016/12/14
TRILOG Antenna	Schwarzbeck	VULB9168	MRTSUE06172	1 year	2016/12/10
Broad-Band Horn Antenna	Schwarzbeck	BBHA9120D	MRTSUE06023	1 year	2016/11/07
Broadband Horn Antenna	Schwarzbeck	BBHA9170	MRTSUE06024	1 year	2017/01/04
RF Cable	HUBER+SU HNER	Cable 01	MRTSUE06055-1	1 year	2017/03/29
RF Cable	HUBER+SU HNER	Cable 02	MRTSUE06055-2	1 year	2017/03/29
Temperature/Humidity Meter	Yuhuaze	HTC-2	MRTSUE06182	1 year	2016/12/20
Anechoic Chamber	TDK	Chamber-AC1	MRTSUE06212	1 year	2017/05/10

Conducted Test Equipment - TR3

Instrument	Manufacturer	Type No.	Asset No.	Cali. Interval	Cali. Due Date
Spectrum Analyzer	Agilent	N9020A	MRTSUE06106	1 year	2016/05/08
USB Wideband Power Sensor	Boonton	55006	MRTSUE06109	1 year	2016/05/08
RF Cable	HUBER+SUHNER	Cable 03	MRTSUE06055-3	1 year	2016/03/29
Attenuator	Woken	WATT-218FS-15	MRTSUE06220	1 year	2016/03/29
DC Block	Woken	00900A1A2A101A	MRTSUE06221	1 year	2016/03/29
Temperature/Humidity Meter	Yuhuaze	HTC-2	MRTSUE06180	1 year	2016/12/20

Software	Version	Function
e3	V 8.3.5	EMI Test Software

6. MEASUREMENT UNCERTAINTY

Where relevant, the following test uncertainty levels have been estimated for tests performed on the EUT as specified in CISPR 16-4-2. This uncertainty represents an expanded uncertainty expressed at approximately the 95% confidence level using a coverage factor of $k = 2$.

AC Conducted Emission Measurement - SR2
Measuring Uncertainty for a Level of Confidence of 95% ($U=2Uc(y)$): 150kHz~30MHz: 3.46dB
Radiated Emission Measurement - AC1
Measuring Uncertainty for a Level of Confidence of 95% ($U=2Uc(y)$): 9kHz ~ 1GHz: 4.18dB 1GHz ~ 40GHz: 4.76dB
Spurious Emissions, Conducted - TR3
Measuring Uncertainty for a Level of Confidence of 95% ($U=2Uc(y)$): 0.78dB
Output Power - TR3
Measuring Uncertainty for a Level of Confidence of 95% ($U=2Uc(y)$): 1.13dB
Power Spectrum Density - TR3
Measuring Uncertainty for a Level of Confidence of 95% ($U=2Uc(y)$): 1.15dB
Occupied Bandwidth - TR3
Measuring Uncertainty for a Level of Confidence of 95% ($U=2Uc(y)$): 0.28%

7. TEST RESULT

7.1. Summary

Company Name: Yuneec Technology Co., Limited
FCC ID: 2ACS5-ST16P
IC: 11554B-ST16P
Data Rate(s) Tested: 6Mbps ~ 54Mbps (a);

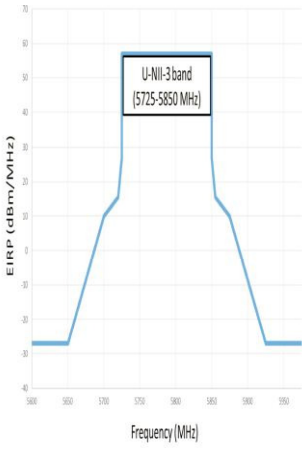
FCC Section(s)	Test Description	Test Limit	Test Condition	Test Result	Reference
15.407(a)	26dB Bandwidth	N/A	Conducted	Pass	Section 7.2
15.407(e)	6dB Bandwidth	≥ 500kHz		Pass	Section 7.3
15.407(a)(3)	Maximum Conducted Output Power	≤ 30 dBm U-NII-3		Pass	Section 7.4
15.407(a)(3), (5)	Peak Power Spectral Density	≤ 30 dBm/500kHz U-NII-3		Pass	Section 7.5
15.407(g)	Frequency Stability	N/A		Pass	Section 7.6
15.407(b)(4)(i)	Undesirable Emissions		Radiated	Pass	Section 7.7 & 7.8
15.205, 15.209 15.407(b)(5), (6), (7)	General Field Strength Limits (Restricted Bands and Radiated Emission Limits)	Emissions in restricted bands must meet the radiated limits detailed in 15.209		Pass	
15.207	RSS-Gen [8.8]	AC Conducted Emissions 150kHz - 30MHz	< FCC 15.207 limits	Line Conducted	Section 7.9

RSS Section(s)	Test Description	Test Limit	Test Condition	Test Result	Reference
RSS-247 §6.2	99% Bandwidth	N/A	Conducted	Pass	Section 7.2
RSS-247 §6.2.4	6dB Bandwidth	>500kHz		Pass	Section 7.3
RSS-247 §6.2.4	Max Conducted Output Power	≤ 30 dBm		Pass	Section 7.4
RSS-247 §6.2.4	Peak Power Spectral Density	≤ 30 dBm/500kHz		Pass	Section 7.5
RSS-Gen [8.11]	Frequency Stability	N/A		Pass	Section 7.6
RSS-247 §6.2.4	Out-of-Band Emissions	≤ -27dBm/MHz EIRP ≤ -17dBm/MHz EIRP	Radiated	Pass	Section 7.7 & 7.8
RSS-247 §6.2.4	General Field Strength Limits (Restricted Bands and Radiated Emission Limits)	Emissions in restricted bands must meet the radiated limits detailed in RSS-Gen [8.9]		Pass	
RSS-Gen [8.8]	AC Conducted Emissions 150kHz - 30MHz	≤ RSS-Gen [8.8] Limit	Line Conducted	Pass	Section 7.9

Notes:

- 1) All channels, modes, and modulations/data rates were investigated among all UNII bands. For radiated emission test, every axis (X, Y, Z) was also verified. The test results shown in the following sections represent the worst case emissions.
- 2) The analyzer plots shown in this section were all taken with a correction table loaded into the analyzer. The correction table was used to account for the losses of the cables and attenuators used as part of the system to connect the EUT to the analyzer at all frequencies of interest.
- 3) All antenna port conducted emissions testing was performed on a test bench with the antenna port of the EUT connected to the spectrum analyzer through calibrated cables and attenuators. The radiated spurious emission and radiated band-edge show the worst case data for the directional antenna in the UNII report.

7.2. 26dB Bandwidth Measurement

7.2.1. Test Limit

N/A

7.2.2. Test Procedure used

KDB 789033 D02v01r02 – Section C.1

7.2.3. Test Setting

1. The analyzers' automatic bandwidth measurement capability was used to perform the 26dB bandwidth measurement. The "X" dB bandwidth parameter was set to $X = 26$. The automatic bandwidth measurement function also has the capability of simultaneously measuring the 99% occupied bandwidth. The bandwidth measurement was not influenced by any intermediated power nulls in the fundamental emission.
2. RBW = approximately 1% of the emission bandwidth.
3. VBW $\geq 3 \times$ RBW.
4. Detector = Peak.
5. Trace mode = max hold.

7.2.4. Test Setup

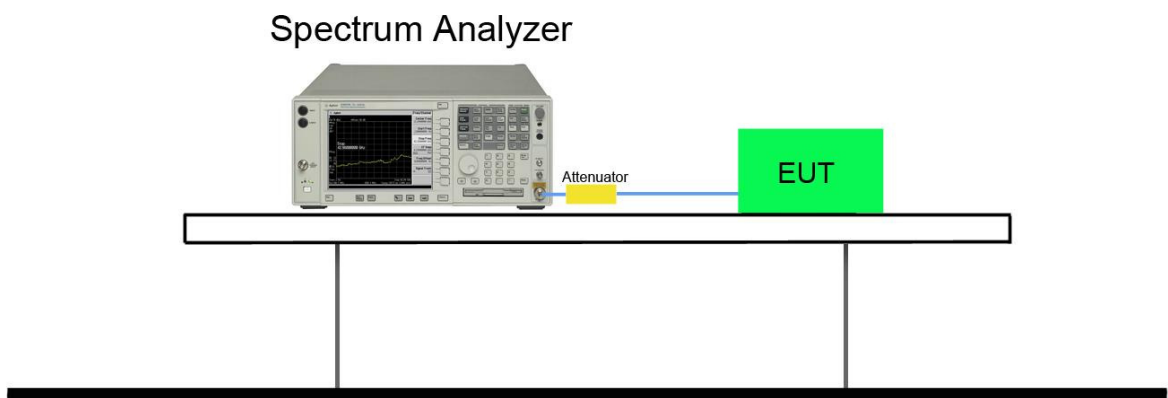

7.2.5. Test Result

Test Mode	Data Rate (Mbps)	Channel No.	Frequency (MHz)	26dB Bandwidth (MHz)	99% Bandwidth (MHz)
802.11a	6	149	5745	21.77	16.70
802.11a	6	157	5785	21.83	16.72
802.11a	6	165	5825	21.76	16.71

802.11a 26dB Bandwidth & 99% Bandwidth

Channel 149 (5745MHz)

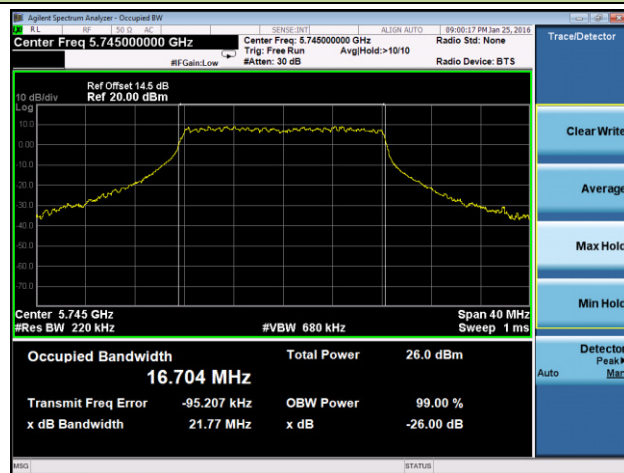

Channel 157 (5785MHz)

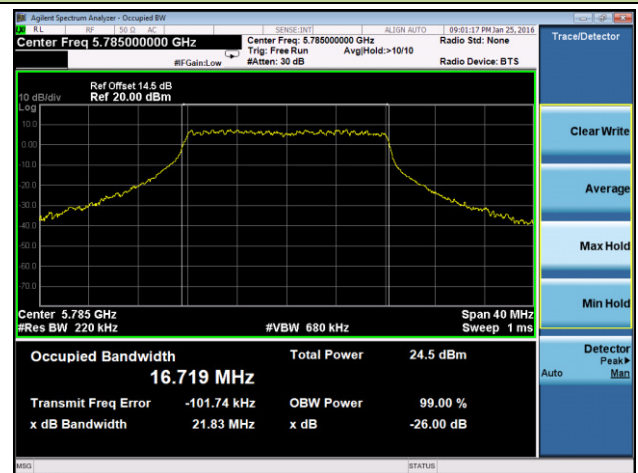

Channel 165 (5825MHz)

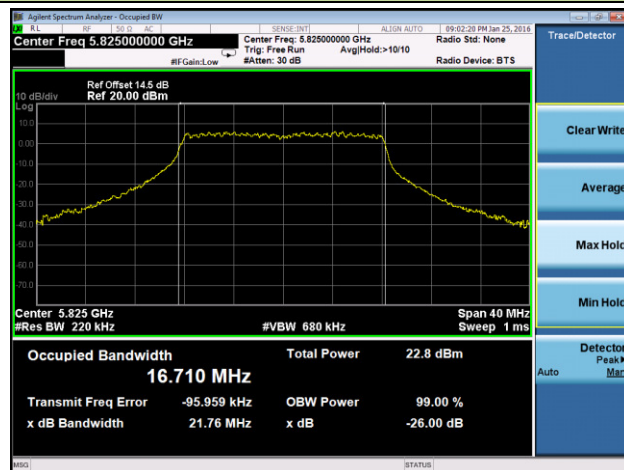

7.3. 6dB Bandwidth Measurement

7.3.1. Test Limit

The minimum 6dB bandwidth shall be at least 500 kHz.

7.3.2. Test Procedure used

KDB 789033 D02v01r02 – Section C.2

7.3.3. Test Setting

1. Set center frequency to the nominal EUT channel center frequency.
2. RBW = 100 kHz.
3. VBW $\geq 3 \times$ RBW.
4. Detector = Peak.
5. Trace mode = max hold.
6. Sweep = auto couple.
7. Allow the trace to stabilize.
8. Measure the maximum width of the emission that is constrained by the frequencies associated with the two outermost amplitude points (upper and lower frequencies) that are attenuated by 6 dB relative to the maximum level measured in the fundamental emission.

7.3.4. Test Setup

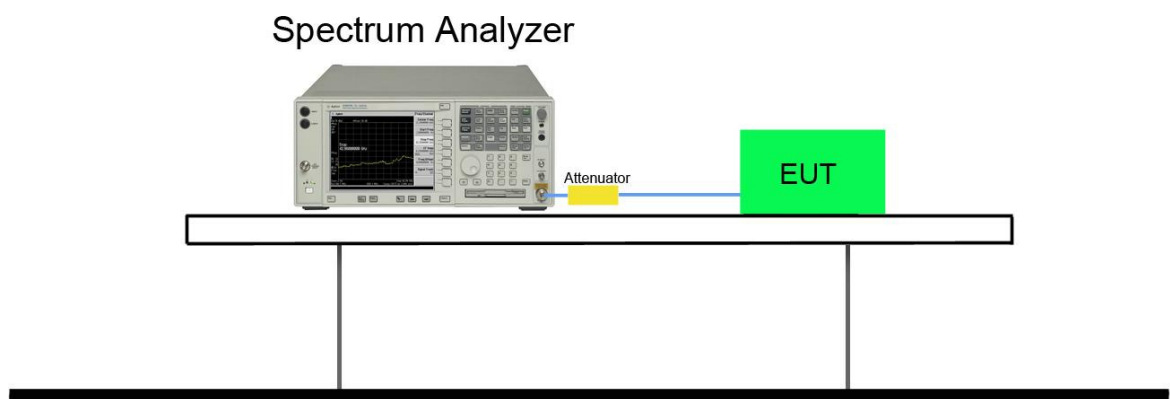

7.3.5. Test Result

Test Mode	Data Rate (Mbps)	Channel No.	Frequency (MHz)	6dB Bandwidth (MHz)	Limit (MHz)	Result
802.11a	6	149	5745	16.54	≥ 0.5	Pass
802.11a	6	157	5785	16.57	≥ 0.5	Pass
802.11a	6	165	5825	16.58	≥ 0.5	Pass

802.11a 6dB Bandwidth

Channel 149 (5745MHz)

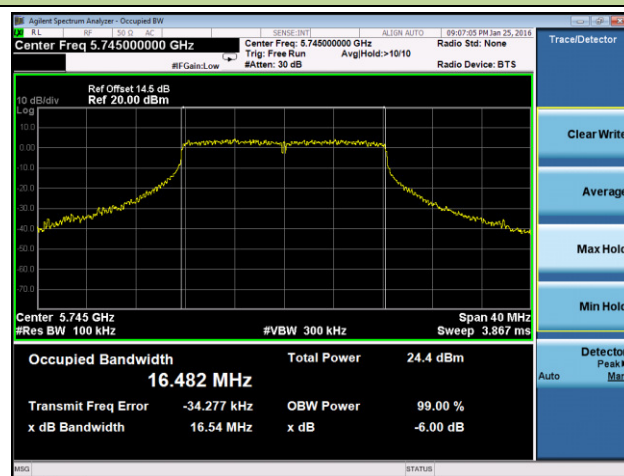

Channel 157 (5785MHz)

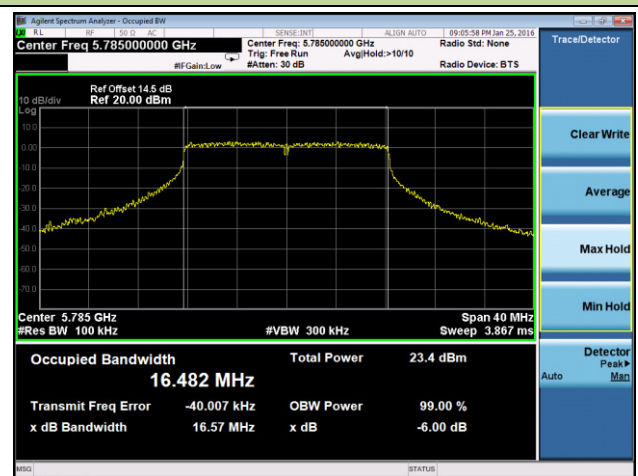

Channel 165 (5825MHz)

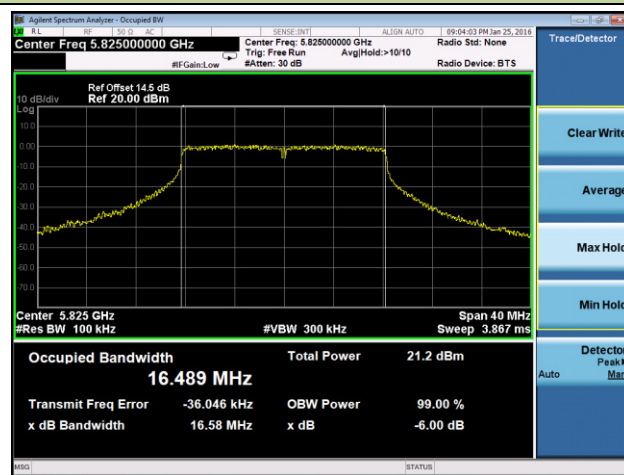

7.4. Output Power Measurement

7.4.1. Test Limit

For FCC

For the band 5.725-5.85 GHz, the maximum conducted output power over the frequency band of operation shall not exceed 1 W (30dBm).

For IC

For the 5.725-5.85 GHz band, the maximum conducted output power shall not exceed 1 W.

7.4.2. Test Procedure Used

KDB 789033 D02v01r02 - Section E) 3) b) Method PM-G

7.4.3. Test Setting

Average power measurements were performed only when the EUT was transmitting at its maximum power control level using a broadband power meter with a pulse sensor. The power meter implemented triggering and gating capabilities which were set up such that power measurements were recorded only during the ON time of the transmitter. The trace was averaged over 100 traces to obtain the final measured average power.

7.4.4. Test Setup

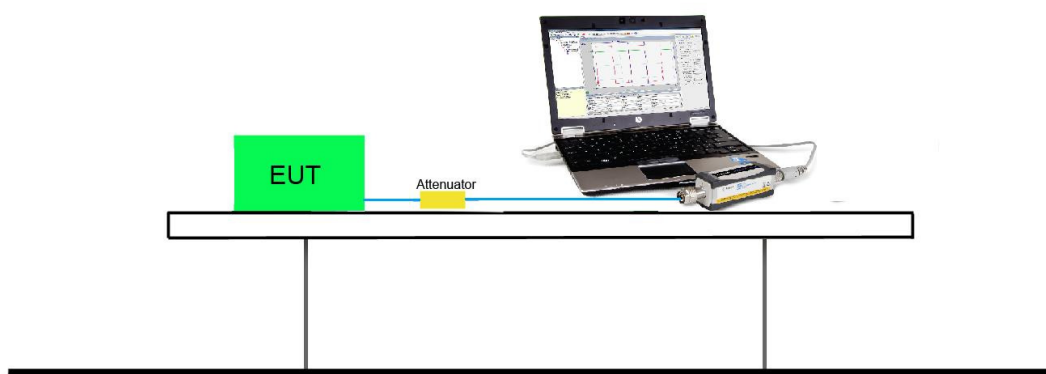

7.4.5. Test Result

Power evaluation under the different rates

Test Mode	Frequency (MHz)	Data Rate (Mbps)	Average Power (dBm)
802.11a	5785	6	19.52
		24	19.31
		54	19.05

Test Mode	Data Rate (Mbps)	Channel No.	Freq. (MHz)	Average Power (dBm)	Limit (dBm)	Result
802.11a	6	149	5745	21.55	≤ 30.00	Pass
802.11a	6	157	5785	19.52	≤ 30.00	Pass
802.11a	6	165	5825	19.42	≤ 30.00	Pass

7.5. Power Spectral Density Measurement

7.5.1. Test Limit

For FCC

For the band 5.725-5.85 GHz, the maximum power spectral density shall not exceed 30 dBm in any 500-kHz band.

For IC

For the 5.725-5.85 GHz band, the power spectral density shall not exceed 30 dBm in any 500 kHz band.

7.5.2. Test Procedure Used

KDB 789033 D02v01r02 - Section F

7.5.3. Test Setting

1. Analyzer was set to the center frequency of the UNII channel under investigation
2. Span was set to encompass the entire 26dB EBW of the signal.
3. RBW = 1MHz, if measurement bandwidth of Maximum PSD is specified in 500 kHz,
RBW = 100 kHz
4. VBW = 3MHz
5. Number of sweep points $\geq 2 \times (\text{span} / \text{RBW})$
6. Detector = power averaging (Average)
7. Sweep time = auto
8. Trigger = free run
9. Use the peak search function on the instrument to find the peak of the spectrum and record its value.
10. Add $10 \cdot \log(1/x)$, where x is the duty cycle, to the measured power in order to compute the average power during the actual transmission times (because the measurement represents an average over both the on and off times of the transmission). For example, add $10 \cdot \log(1/0.25) = 6$ dB if the duty cycle is 25 percent.
11. When the measurement bandwidth of Maximum PSD is specified in 500 kHz, add a constant factor $10 \cdot \log(500\text{kHz}/100\text{kHz}) = 7$ dB to the measured result

7.5.4. Test Setup

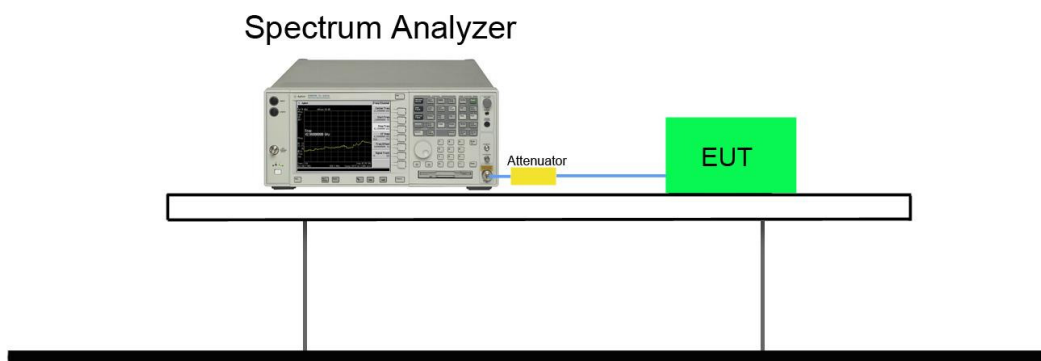

7.5.5. Test Result

Test Mode	Data Rate (Mbps)	Channel No.	Freq. (MHz)	PSD (dBm/100kHz)	Duty Cycle (%)	Constant Factor	Total PSD (dBm/500kHz)	Limit (dBm/500kHz)	Result
802.11a	6	149	5745	-0.352	100	7	6.648	≤ 30.00	Pass
802.11a	6	157	5785	-0.924	100	7	6.076	≤ 30.00	Pass
802.11a	6	165	5825	-2.842	100	7	4.158	≤ 30.00	Pass

Note: When EUT duty cycle = 100%, Total PSD (dBm/500kHz) = PSD (dBm/100kHz) + Constant Factor.

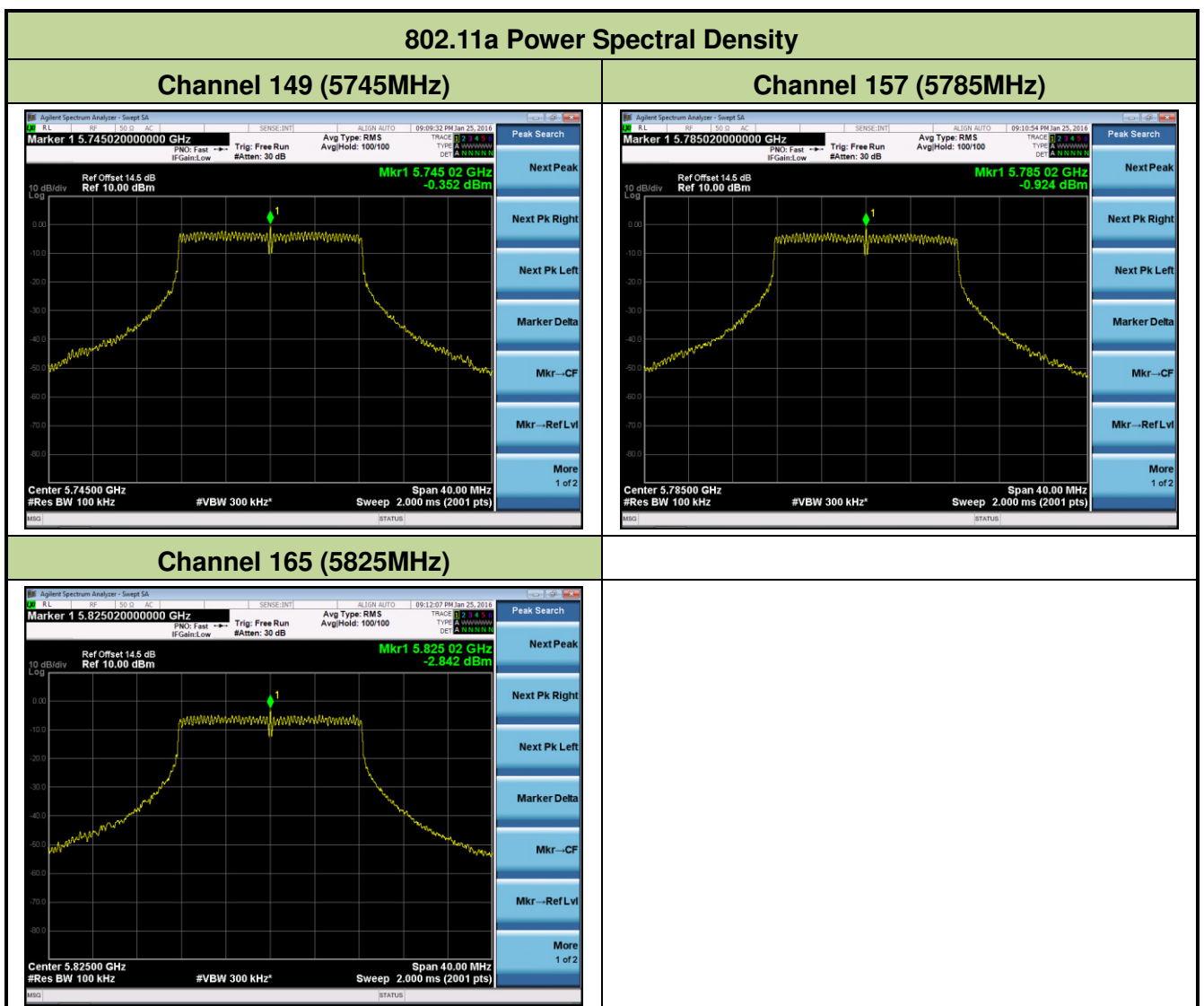

7.6. Frequency Stability Measurement

7.6.1. Test Limit

Manufactures of U-NII devices are responsible for ensuring frequency stability such that an emission is maintained within the band of operation under all conditions of normal operation as specified in the user's manual.

7.6.2. Test Procedure Used

Frequency Stability Under Temperature Variations:

The equipment under test was connected to an external AC or DC power supply and input rated voltage. RF output was connected to a frequency counter or spectrum analyzer via feed through attenuators. The EUT was placed inside the temperature chamber. Set the spectrum analyzer RBW low enough to obtain the desired frequency resolution and measure EUT 20°C operating frequency as reference frequency. Turn EUT off and set the chamber temperature to highest. After the temperature stabilized for approximately 30 minutes recorded the frequency. Repeat step measure with 10°C decreased per stage until the lowest temperature reached.

Frequency Stability Under Voltage Variations:

Set chamber temperature to 20°C. Use a variable AC power supply / DC power source to power the EUT and set the voltage to rated voltage. Set the spectrum analyzer RBW low enough to obtain the desired frequency resolution and recorded the frequency.

Reduce the input voltage to specify extreme voltage variation ($\pm 15\%$) and endpoint, record the maximum frequency change.

7.6.3. Test Setup

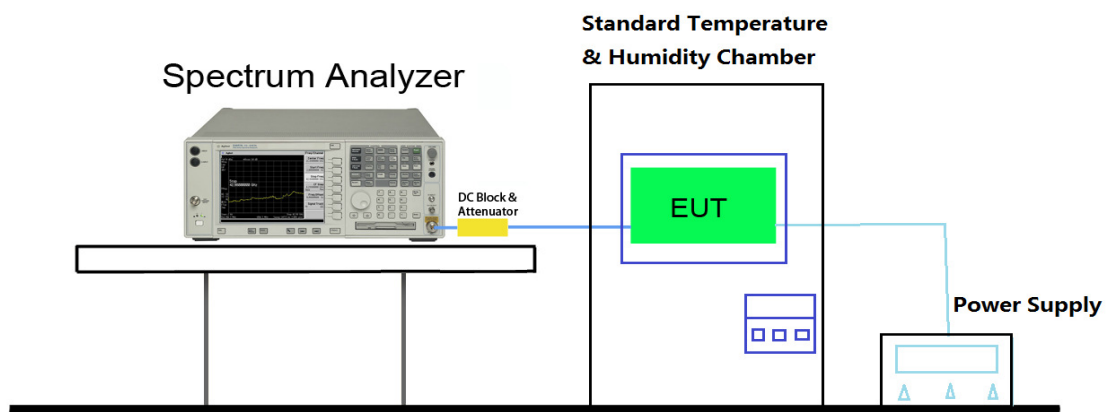

7.6.4. Test Result

Test Engineer	Milo Li	Temperature	-30 ~ 50°C
Test Time	01-26-2016	Relative Humidity	52%RH

Voltage (%)	Power (VAC)	Temp (°C)	Frequency Tolerance (ppm)			
			0 minutes	2 minutes	5 minutes	10 minutes
100%	3.6	- 30	-2.70	-4.66	-3.44	-3.53
		- 20	-1.07	-3.27	1.64	-4.19
		- 10	3.67	-1.95	3.49	-2.07
		0	4.64	-2.21	-1.84	-0.19
		+ 10	2.11	-3.56	-2.17	2.26
		+ 20 (Ref)	-4.65	1.79	-3.67	3.35
		+ 30	1.85	2.65	-2.03	-4.14
		+ 40	-2.03	-3.33	2.84	0.95
		+ 50	-3.01	1.27	-3.54	2.35
115%	4.14	+ 20	-4.15	-1.15	1.98	1.39
85%	3.06	+ 20	-3.82	-2.40	-3.22	-3.44

Note: Frequency Tolerance (ppm) = $\frac{\{[\text{Measured Frequency (Hz)} - \text{Declared Frequency (Hz)}]\}}{\text{Declared Frequency (Hz)}} * 10^6$.

7.7. Radiated Spurious Emission Measurement

7.7.1. Test Limit

All out of band emissions appearing in a restricted band as specified in Section 15.205 of the Title 47 CFR must not exceed the limits shown in Table per Section 15.209.

FCC Part 15 Subpart C Paragraph 15.209		
Frequency [MHz]	Field Strength [uV/m]	Measured Distance [Meters]
0.009 – 0.490	2400/F (kHz)	300
0.490 – 1.705	24000/F (kHz)	30
1.705 - 30	30	30
30 - 88	100	3
88 - 216	150	3
216 - 960	200	3
Above 960	500	3

7.7.2. Test Procedure Used

KDB 789033 D02v01r02 – Section G

7.7.3. Test Setting

Peak Measurements above 1GHz

1. Analyzer center frequency was set to the frequency of the radiated spurious emission of interest
2. RBW = 1MHz
3. VBW = 3MHz
4. Detector = peak
5. Sweep time = auto couple
6. Trace mode = max hold
7. Trace was allowed to stabilize

Quasi-Peak Measurements below 1GHz

1. Analyzer center frequency was set to the frequency of the radiated spurious emission of interest
2. Span was set greater than 1MHz
3. RBW = 120 kHz
4. Detector = CISPR quasi-peak
5. Sweep time = auto couple
6. Trace was allowed to stabilize

Average Measurements above 1GHz (Method AD)

1. Analyzer center frequency was set to the frequency of the radiated spurious emission of interest
2. RBW = 1MHz
3. VBW = 3MHz
4. Detector = power average (Average)
5. Number of measurement points = 1001 (Number of points must be $> 2 \times \text{span}/\text{RBW}$)
6. Sweep time = auto
7. Trace was averaged over at 100 sweeps

7.7.4. Test Setup

9kHz ~ 30MHz Test Setup:

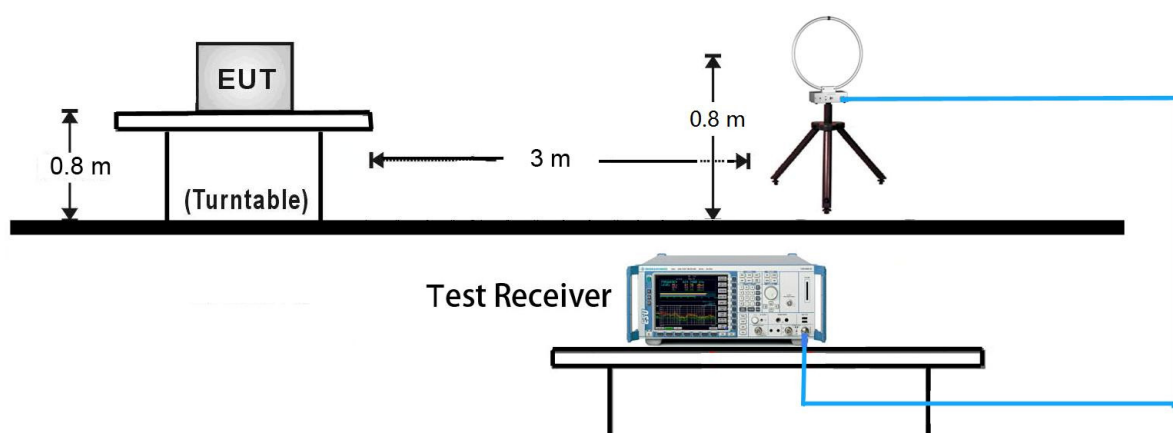

30MHz ~ 1GHz Test Setup:

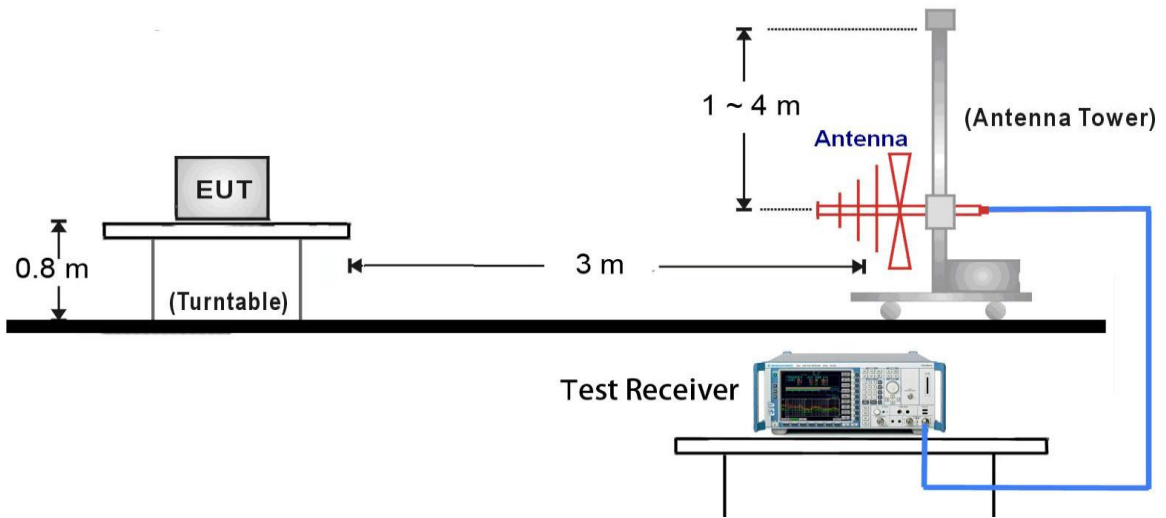

1GHz ~ 18GHz Test Setup:

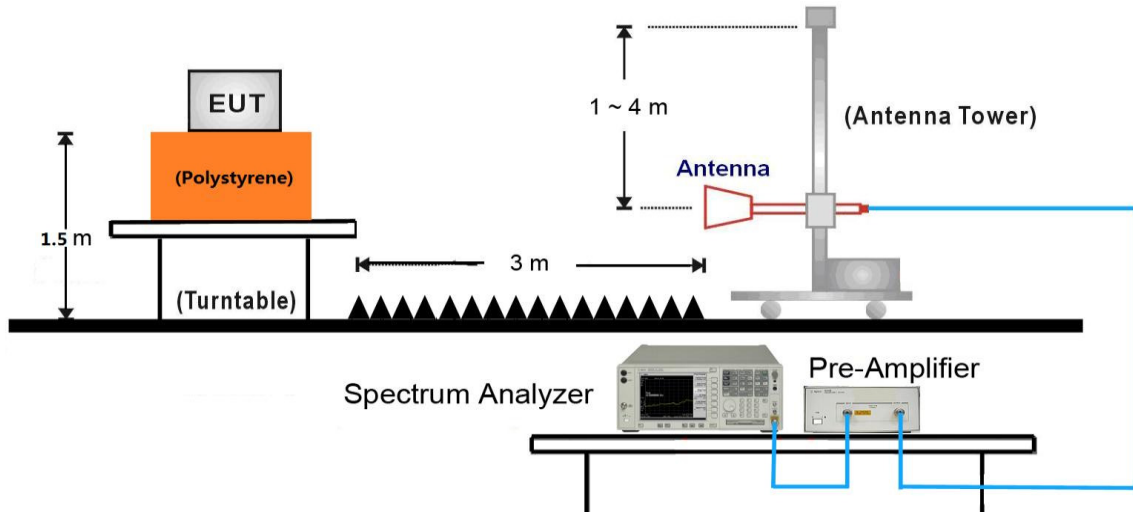

18GHz ~ 40GHz Test Setup:

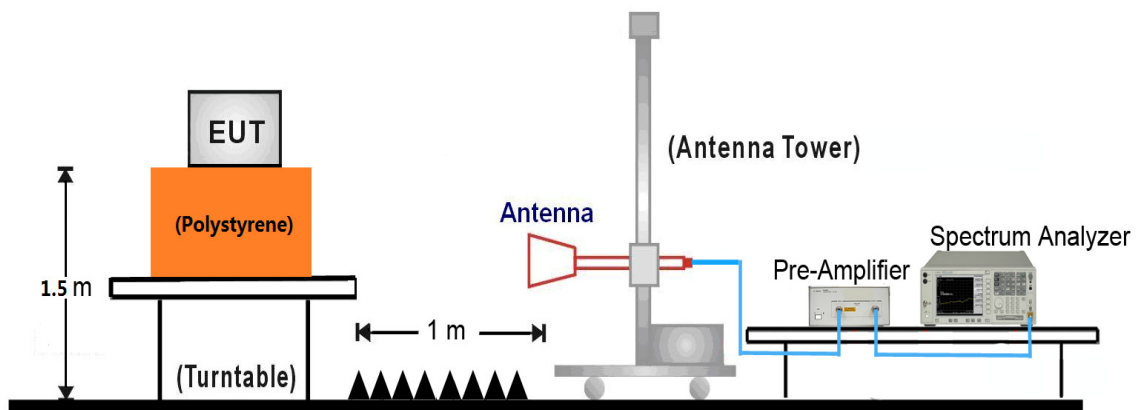

7.7.5. Test Result

Test Mode:	802.11a	Test Site:	AC1
Test Channel:	149	Test Engineer:	Lewis Huang
Remark:	1. Average measurement was not performed if peak level lower than average limit. 2. Other frequency was 20dB below limit line within 1-18GHz, there is not show in the report.		

Mark	Frequency (MHz)	Reading Level (dB μ V)	Factor (dB)	Measure Level (dB μ V/m)	Limit (dB μ V/m)	Margin (dB)	Detector	Polarization
*	6644.0	35.7	6.0	41.7	68.2	-26.5	Peak	Horizontal
*	8692.5	34.6	9.0	43.6	68.2	-24.6	Peak	Horizontal
	9466.0	34.2	10.5	44.7	74.0	-29.3	Peak	Horizontal
	11047.0	35.1	12.9	48.0	74.0	-26.0	Peak	Horizontal
*	6695.0	36.1	5.8	41.9	68.2	-26.3	Peak	Vertical
*	8777.5	35.0	8.9	43.9	68.2	-24.3	Peak	Vertical
	9440.5	34.7	10.5	45.2	74.0	-28.8	Peak	Vertical
	11650.5	38.3	12.3	50.6	74.0	-23.4	Peak	Vertical

Note 1: "*" is not in restricted band, its limit is -27dBm/MHz or -17dBm/MHz. At a distance of 3 meters, the field strength limit in dB μ V/m can be determined by adding a "conversion" factor of 95.2dB to the EIRP limit of -27dBm/MHz to obtain the limit for out of band spurious emissions.

Note 2: Measure Level (dB μ V/m) = Reading Level (dB μ V) + Factor (dB)

Factor (dB) = Cable Loss (dB) + Antenna Factor (dB/m) – Pre_Amplifier Gain (dB)

Test Mode:	802.11a	Test Site:	AC1
Test Channel:	157	Test Engineer:	Lewis Huang
Remark:	1. Average measurement was not performed if peak level lower than average limit. 2. Other frequency was 20dB below limit line within 1-18GHz, there is not show in the report.		

Mark	Frequency (MHz)	Reading Level (dBμV)	Factor (dB)	Measure Level (dBμV/m)	Limit (dBμV/m)	Margin (dB)	Detector	Polarization
*	6576.0	34.9	6.0	40.9	68.2	-27.3	Peak	Horizontal
*	8658.5	34.4	8.8	43.2	68.2	-25.0	Peak	Horizontal
	9423.5	33.6	10.6	44.2	74.0	-29.8	Peak	Horizontal
	11565.5	41.0	12.7	53.7	74.0	-20.3	Peak	Horizontal
*	6822.5	35.2	6.2	41.4	68.2	-26.8	Peak	Vertical
*	8718.0	35.0	9.0	44.0	68.2	-24.2	Peak	Vertical
	9381.0	33.9	10.5	44.4	74.0	-29.6	Peak	Vertical
	11574.0	40.7	12.6	53.3	74.0	-20.7	Peak	Vertical

Note 1: "*" is not in restricted band, its limit is -27dBm/MHz or -17dBm/MHz. At a distance of 3 meters, the field strength limit in dBμV/m can be determined by adding a "conversion" factor of 95.2dB to the EIRP limit of -27dBm/MHz to obtain the limit for out of band spurious emissions.

Note 2: Measure Level (dBμV/m) = Reading Level (dBμV) + Factor (dB)

Factor (dB) = Cable Loss (dB) + Antenna Factor (dB/m) – Pre_Amplifier Gain (dB)

Test Mode:	802.11a	Test Site:	AC1
Test Channel:	165	Test Engineer:	Lewis Huang
Remark:	1. Average measurement was not performed if peak level lower than average limit. 2. Other frequency was 20dB below limit line within 1-18GHz, there is not show in the report.		

Mark	Frequency (MHz)	Reading Level (dBμV)	Factor (dB)	Measure Level (dBμV/m)	Limit (dBμV/m)	Margin (dB)	Detector	Polarization
*	6635.5	34.9	6.0	40.9	68.2	-27.3	Peak	Horizontal
*	8726.5	35.5	9.0	44.5	68.2	-23.7	Peak	Horizontal
	9381.0	34.4	10.5	44.9	74.0	-29.1	Peak	Horizontal
	11490.1	43.2	12.8	56.0	74.0	-18.0	Peak	Horizontal
	11490.1	31.2	12.8	44.0	54.0	-10.0	Average	Horizontal
*	6652.5	34.8	6.0	40.8	68.2	-27.4	Peak	Vertical
*	8718.0	34.7	9.0	43.7	68.2	-24.5	Peak	Vertical
	9338.5	34.3	10.4	44.7	74.0	-29.3	Peak	Vertical
	11490.2	41.6	12.8	54.4	74.0	-19.6	Peak	Vertical
	11490.2	30.3	12.8	43.1	54.0	-10.9	Average	Vertical

Note 1: “*” is not in restricted band, its limit is -27dBm/MHz or -17dBm/MHz. At a distance of 3 meters, the field strength limit in dBμV/m can be determined by adding a “conversion” factor of 95.2dB to the EIRP limit of -27dBm/MHz to obtain the limit for out of band spurious emissions.

Note 2: Measure Level (dBμV/m) = Reading Level (dBμV) + Factor (dB)

Factor (dB) = Cable Loss (dB) + Antenna Factor (dB/m) – Pre_Amplifier Gain (dB)

The worst case of Radiated Emission below 1GHz:

Site: AC1	Time: 2016/07/19 - 18:49
Limit: FCC_Part15.209_RE(3m)	Engineer: Lewis Huang
Probe: VULB9162_0.03-8GHz	Polarity: Horizontal
EUT: Personal Ground Station	Power: By Battery
Worse Case Mode: Transmit at Channel 5745MHz by 802.11a	

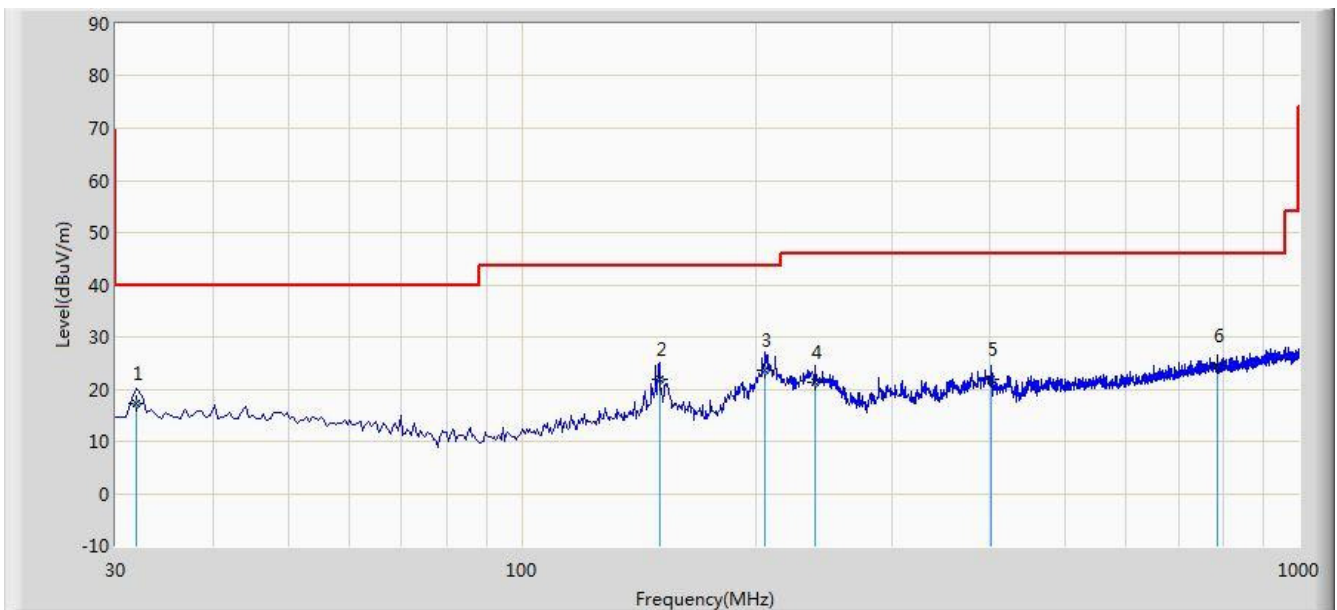

No	Flag	Mark	Frequency (MHz)	Measure Level (dBuV/m)	Reading Level (dBuV)	Over Limit (dB)	Limit (dBuV/m)	Factor (dB)	Type
1			31.940	17.111	3.421	-22.889	40.000	13.690	QP
2			150.280	21.876	6.714	-21.624	43.500	15.162	QP
3		*	205.570	23.564	12.370	-19.936	43.500	11.194	QP
4			238.550	21.372	8.647	-24.628	46.000	12.725	QP
5			401.995	21.863	5.314	-24.137	46.000	16.549	QP
6			785.630	24.483	1.357	-21.517	46.000	23.126	QP

Note: Measure Level (dB μ V/m) = Reading Level (dB μ V) + Factor (dB)

Factor (dB) = Cable Loss (dB) + Antenna Factor (dB/m)

Site: AC1	Time: 2016/07/19 - 18:50
Limit: FCC_Part15.209_RE(3m)	Engineer: Lewis Huang
Probe: VULB9162_0.03-8GHz	Polarity: Vertical
EUT: Personal Ground Station	Power: By Battery
Worse Case Mode: Transmit at Channel 5745MHz by 802.11a	

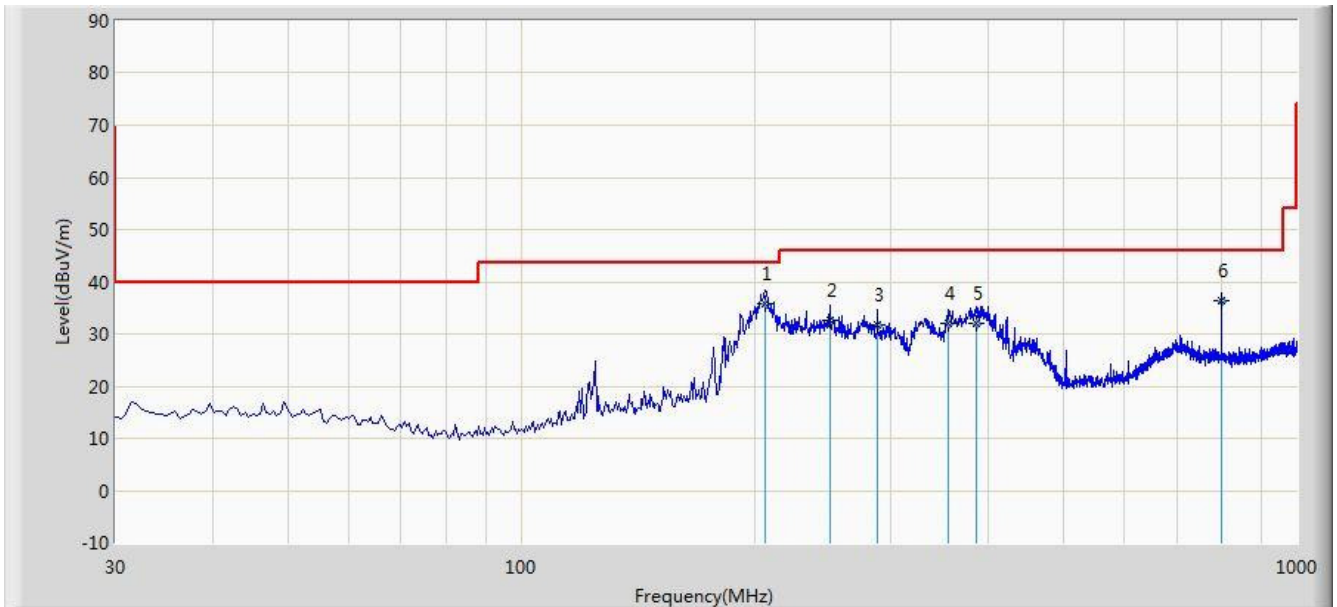

No	Flag	Mark	Frequency (MHz)	Measure Level (dBuV/m)	Reading Level (dBuV)	Over Limit (dB)	Limit (dBuV/m)	Factor (dB)	Type
1		*	206.055	35.834	24.638	-7.666	43.500	11.196	QP
2			250.190	32.590	19.654	-13.410	46.000	12.936	QP
3			288.020	31.642	17.650	-14.358	46.000	13.992	QP
4			355.435	31.933	16.358	-14.067	46.000	15.575	QP
5			385.990	31.911	15.687	-14.089	46.000	16.224	QP
6			800.180	36.435	13.240	-9.565	46.000	23.195	QP

Note: Measure Level (dBuV/m) = Reading Level (dBuV) + Factor (dB)

Factor (dB) = Cable Loss (dB) + Antenna Factor (dB/m)

Site: AC1	Time: 2016/07/15 - 19:18
Limit: FCC_Part15.209_RE(3m)	Engineer: Milo Li
Probe: FMZB1519_0.009-30MHz	Polarity: Face on
EUT: Personal Ground Station	Power: By Battery
Note: There is the ambient noise within frequency range 9kHz~30MHz.	

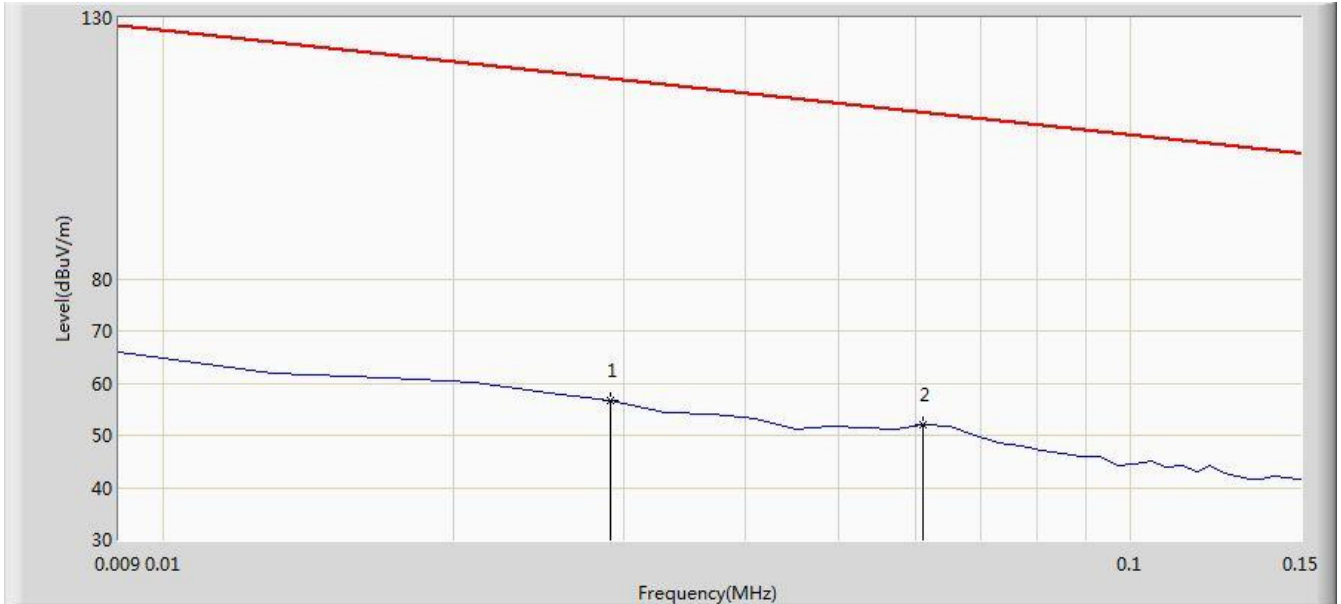

No	Flag	Mark	Frequency (MHz)	Measure Level (dBuV/m)	Reading Level (dBuV)	Over Limit (dB)	Limit (dBuV/m)	Factor (dB)	Type
1			0.029	56.610	35.660	-61.732	118.342	21.049	QP
2		*	0.061	51.899	31.588	-59.988	111.887	20.311	QP

Note: Measure Level (dB μ V/m) = Reading Level (dB μ V) + Factor (dB)

Factor (dB) = Cable Loss (dB) + Antenna Factor (dB/m)

Site: AC1	Time: 2016/07/15 - 19:19
Limit: FCC_Part15.209_RE(3m)	Engineer: Milo Li
Probe: FMZB1519_0.009-30MHz	Polarity: Face on
EUT: Personal Ground Station	Power: By Battery
Note: There is the ambient noise within frequency range 9kHz~30MHz.	

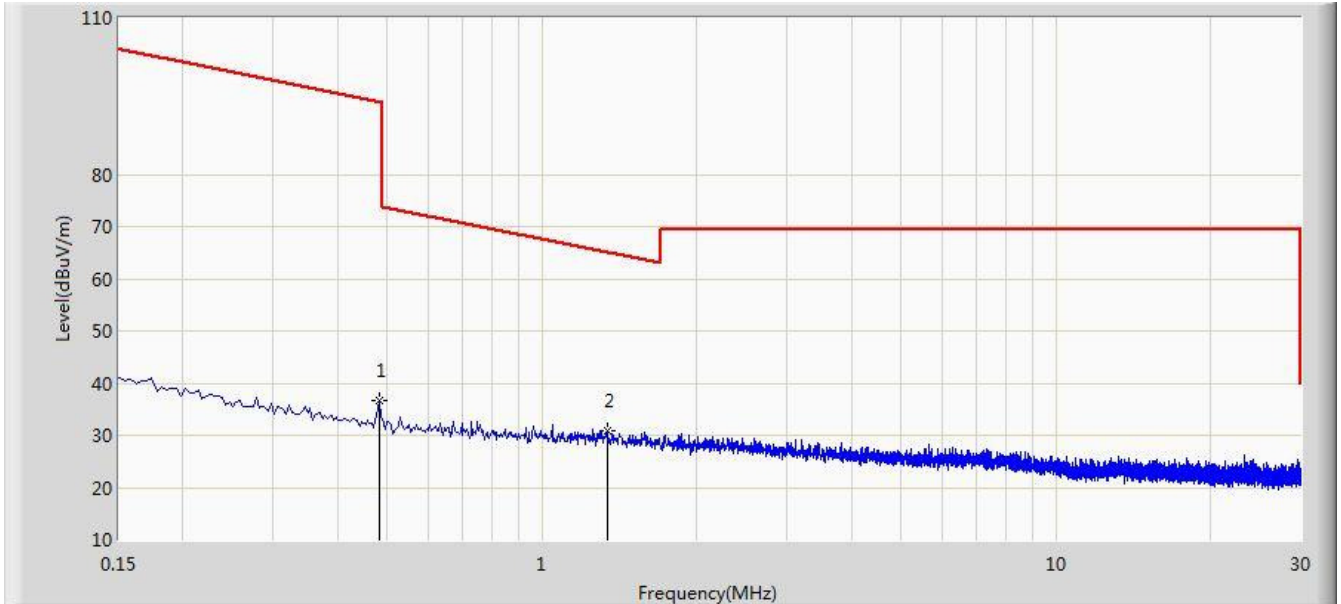

No	Flag	Mark	Frequency (MHz)	Measure Level (dBuV/m)	Reading Level (dBuV)	Over Limit (dB)	Limit (dBuV/m)	Factor (dB)	Type
1			0.482	36.584	16.183	-57.359	93.943	20.401	QP
2		*	1.338	31.001	10.512	-34.098	65.099	20.489	QP

Note: Measure Level (dB μ V/m) = Reading Level (dB μ V) + Factor (dB)

Factor (dB) = Cable Loss (dB) + Antenna Factor (dB/m)

Site: AC1	Time: 2016/07/15 - 17:25
Limit: FCC_Part15.209_RE(1m)	Engineer: Lewis Huang
Probe: BBHA9170_18-40GHz	Polarity: Horizontal
EUT: Personal Ground Station	Power: By Battery
Note: There is the ambient noise within frequency range 18GHz~40GHz.	

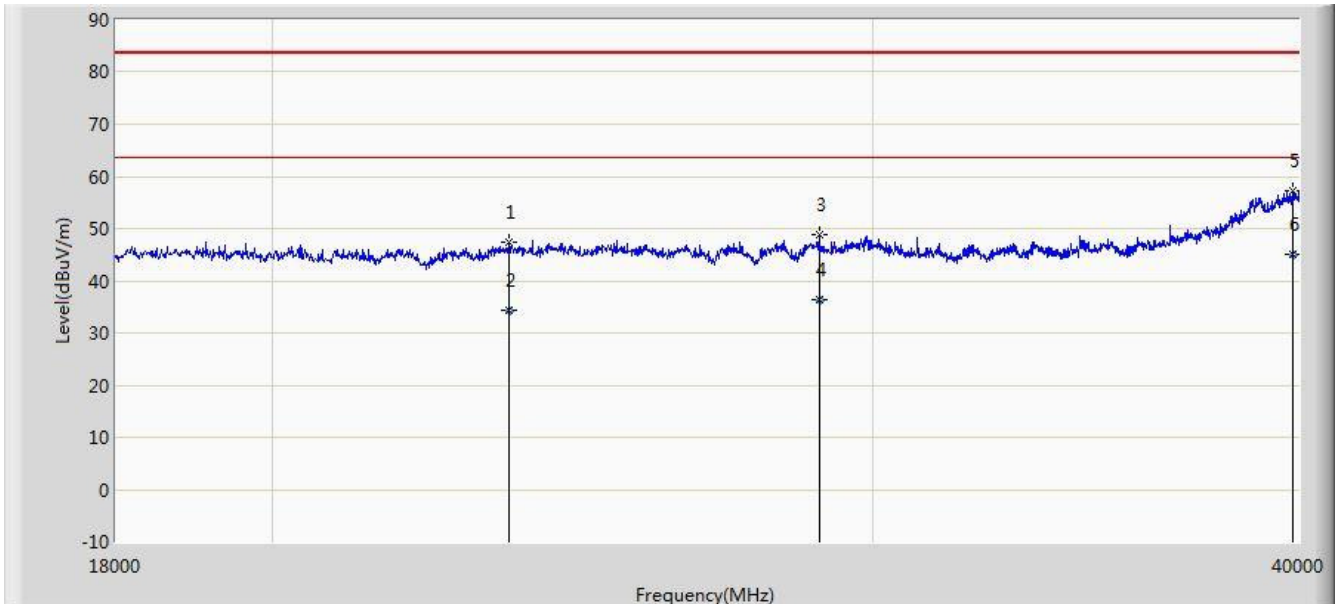

No	Flag	Mark	Frequency (MHz)	Measure Level (dBuV/m)	Reading Level (dBuV)	Over Limit (dB)	Limit (dBuV/m)	Factor (dB)	Type
1			23478.000	47.365	37.708	-36.135	83.500	9.658	PK
2			23478.200	34.298	24.640	-29.202	63.500	9.658	AV
3			28934.000	48.749	35.930	-34.751	83.500	12.819	PK
4			28934.100	36.459	23.640	-27.041	63.500	12.818	AV
5			39857.000	57.224	38.474	-26.276	83.500	18.751	PK
6		*	39857.000	45.090	26.340	-18.410	63.500	18.751	AV

Note: Measure Level (dB μ V/m) = Reading Level (dB μ V) + Factor (dB)

Factor (dB) = Cable Loss (dB) + Antenna Factor (dB/m) – Pre_Amplifier Gain (dB)

Limit@1m = 20*Log(500uV/m) + 20*Log(3m/1m) = 63.5dB μ V/m (Average detector), and 83.5dB μ V/m (Peak detector).

Site: AC1	Time: 2016/07/15 - 17:28
Limit: FCC_Part15.209_RE(1m)	Engineer: Lewis Huang
Probe: BBHA9170_18-40GHz	Polarity: Vertical
EUT: Personal Ground Station	Power: By Battery
Note: There is the ambient noise within frequency range 18GHz~40GHz.	

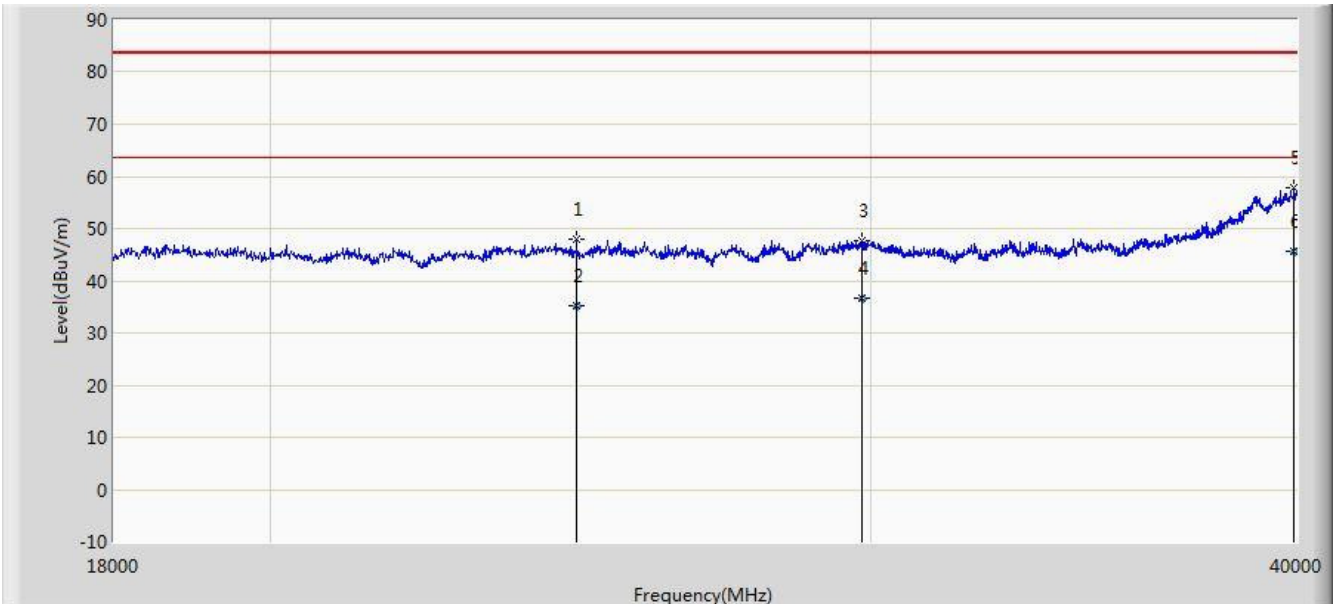

No	Flag	Mark	Frequency (MHz)	Measure Level (dBuV/m)	Reading Level (dBuV)	Over Limit (dB)	Limit (dBuV/m)	Factor (dB)	Type
1			24600.000	47.827	36.853	-35.673	83.500	10.974	PK
2			24600.200	35.124	24.150	-28.376	63.500	10.974	AV
3			29825.000	47.825	34.761	-35.675	83.500	13.064	PK
4			29825.200	36.594	23.530	-26.906	63.500	13.064	AV
5			39923.000	57.939	39.179	-25.561	83.500	18.760	PK
6		*	39923.040	45.610	26.850	-17.890	63.500	18.760	AV

Note: Measure Level (dB μ V/m) = Reading Level (dB μ V) + Factor (dB)

Factor (dB) = Cable Loss (dB) + Antenna Factor (dB/m) – Pre_Amplifier Gain (dB)

Limit@1m = 20*Log(500 μ V/m) + 20*Log(3m/1m) = 63.5dB μ V/m (Average detector), and 83.5dB μ V/m (Peak detector).

7.8. Radiated Restricted Band Edge Measurement

7.8.1. Test Limit

For 15.205 requirement:

Radiated emissions which fall in the restricted bands, as defined in Section 15.205(a) of FCC part 15, must also comply with the radiated emission limits specified in Section 15.209(a).

Frequency (MHz)	Frequency (MHz)	Frequency (MHz)	Frequency (GHz)
0.090 - 0.110	16.42 - 16.423	399.9 - 410	4.5 - 5.15
¹ 0.495 - 0.505	16.69475 - 16.69525	608 - 614	5.35 - 5.46
2.1735 - 2.1905	16.80425 - 16.80475	960 - 1240	7.25 - 7.75
4.125 - 4.128	25.5 - 25.67	1300 - 1427	8.25 - 8.5
4.17725 - 4.17775	37.5 - 38.25	1435 - 1626.5	9.0 - 9.2
4.20725 - 4.20775	73 - 74.6	1645.5 - 1646.5	9.3 - 9.5
6.215 - 6.218	74.8 - 75.2	1660 - 1710	10.6 - 12.7
6.26775 - 6.26825	108 - 121.94	1718.8 - 1722.2	13.25 - 13.4
6.31175 - 6.31225	123 - 138	2200 - 2300	14.47 - 14.5
8.291 - 8.294	149.9 - 150.05	2310 - 2390	15.35 - 16.2
8.362 - 8.366	156.52475 - 156.525	2483.5 - 2500	17.7 - 21.4
8.37625 - 8.38675	156.7 - 156.9	2690 - 2900	22.01 - 23.12
8.41425 - 8.41475	162.0125 - 167.17	3260 - 3267	23.6 - 24.0
12.29 - 12.293	167.72 - 173.2	3332 - 3339	31.2 - 31.8
12.51975 - 12.52025	240 - 285	3345.8 - 3358	36.43 - 36.5
12.57675 - 12.57725	322 - 335.4	3600 - 4400	(²)
13.36 - 13.41	--	--	--

For RSS-Gen Section 8.10 Requirement:

Radiated emissions which fall in the restricted bands, as defined in Section 8.10 of RSS-Gen, must also comply with the radiated emission limits specified in Section 8.9.

Frequency (MHz)	Frequency (MHz)	Frequency (GHz)
0.009 - 0.110	240 - 285	9.0 - 9.2
2.1735 - 2.1905	322 - 335.4	9.3 - 9.5
3.020 - 3.026	399.9 - 410	10.6 - 12.7
4.125 - 4.128	608 - 614	13.25 - 13.4
4.17725 - 4.17775	960 - 1427	14.47 - 14.5
4.20725 - 4.20775	1435 - 1626.5	15.35 - 16.2
5.677 - 5.683	1645.5 - 1646.5	17.7 - 21.4
6.215 - 6.218	1660 - 1710	22.01 - 23.12
6.26775 - 6.26825	1718.8 - 1722.2	23.6 - 24.0
6.31175 - 6.31225	2200 - 2300	31.2 - 31.8
8.291 - 8.294	2310 - 2390	36.43 - 36.5
8.362 - 8.366	2655 - 2900	Above 38.6
8.37625 - 8.38675	3260 - 3267	--
8.41425 - 8.41475	3332 - 3339	
12.29 - 12.293	334.5 - 3358	
12.51975 - 12.52025	3500 - 4400	
12.57675 - 12.57725	4500 - 5150	
13.36 - 13.41	5350 - 5460	
16.42 - 16.423	7250 - 7750	
16.69475 - 16.69525	8025 - 8500	
16.80425 - 16.80475	--	
25.5 - 25.67		
37.5 - 38.25		
73 - 74.6		
74.8 - 75.2		
108 - 138		
156.52475 - 156.525225		
156.7 - 156.9		

Note: *Certain frequency bands listed in Table 6 and in bands above 38.6 GHz are designated for licence-exempt applications. These frequency bands and the requirements that apply to the

devices are set out in the 200- and 300-series of RSSs, such as RSS-210 and RSS-310, which contain the requirements that apply to licence-exempt radio apparatus.

For 15.407(b) requirement:

For transmitters operating in the 5.725-5.85 GHz band: All emissions shall be limited to a level of -27 dBm/MHz at 75 MHz or more above or below the band edge increasing linearly to 10 dBm/MHz at 25 MHz above or below the band edge, and from 25 MHz above or below the band edge increasing linearly to a level of 15.6 dBm/MHz at 5 MHz above or below the band edge, and from 5 MHz above or below the band edge increasing linearly to a level of 27 dBm/MHz at the band edge.

Refer to KDB 789033 D02v01r02 G)2)c), as 15.407(b)(1) - (3) specifies that emissions outside of the respective U-NII bands are subject to a maximum emission limit of -27 dBm/MHz. § 5.407(b)(4) provides two requirement options for devices that operate in the 5.725 - 5.85 GHz band. If the option specified in § 15.407(b)(4)(ii) is exercised, then the procedures specified in Clause 11.11 of ANSI C63.10-2013 and/or in Section 11.0 of KDB Publication 558074 shall be utilized. In general, an out-of-band emission that complies with both the peak and average power limits of § 15.209 is not required to also satisfy the -27 dBm/MHz or -17 dBm/MHz maximum emission limit.

All out of band emissions appearing in a restricted band as specified in Section 15.205 of the Title 47 CFR must not exceed the limits shown in Table per Section 15.209.

FCC Part 15 Subpart C Paragraph 15.209		
Frequency [MHz]	Field Strength [V/m]	Measured Distance [Meters]
0.009 – 0.490	2400/F (kHz)	300
0.490 – 1.705	24000/F (kHz)	30
1.705 - 30	30	30
30 - 88	100	3
88 - 216	150	3
216 - 960	200	3
Above 960	500	3

7.8.2. Test Result of Radiated Restricted Band Edge

For FCC requirement

Site: AC1	Time: 2016/07/13 - 20:14
Limit: FCC_Part15.407_RE(3m)	Engineer: Vince Yu
Probe: BBHA9120D_1-18GHz	Polarity: Horizontal
EUT: Personal Ground Station	Power: By Battery
Test Mode: Transmit by 802.11a at Channel 5745MHz	

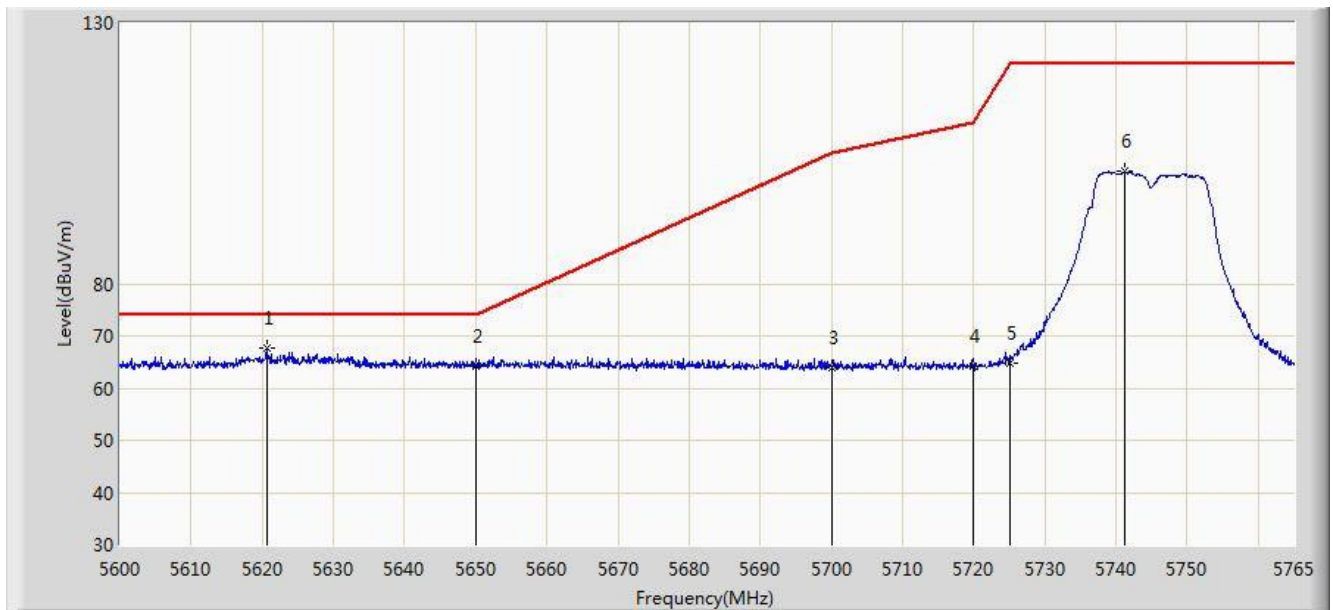

No	Flag	Mark	Frequency (MHz)	Measure Level (dBuV/m)	Reading Level (dBuV)	Over Limit (dB)	Limit (dBuV/m)	Factor (dB)	Type
1		*	5620.625	67.622	29.886	-6.378	74.000	37.735	PK
2			5650.000	64.231	26.444	-9.769	74.000	37.787	PK
3			5700.000	63.886	25.994	-41.314	105.200	37.892	PK
4			5720.000	64.272	26.303	-46.528	110.800	37.970	PK
5			5725.000	64.652	26.662	-57.548	122.200	37.990	PK
6			5741.322	101.466	63.410	N/A	N/A	38.056	PK

Note: Measure Level (dBuV/m) = Reading Level (dBuV) + Factor (dB)

Factor (dB) = Cable Loss (dB) + Antenna Factor (dB/m)

Site: AC1	Time: 2016/07/13 - 20:19
Limit: FCC_Part15.407_RE(3m)	Engineer: Vince Yu
Probe: BBHA9120D_1-18GHz	Polarity: Vertical
EUT: Personal Ground Station	Power: By Battery
Test Mode: Transmit by 802.11a at Channel 5745MHz	

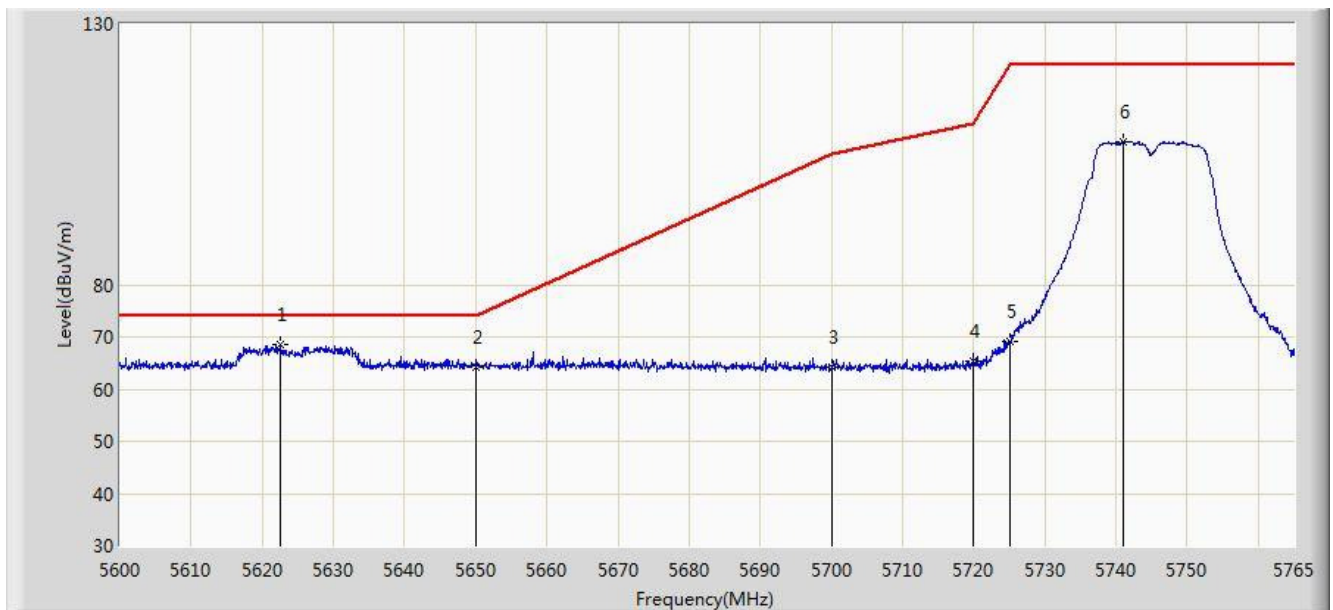

No	Flag	Mark	Frequency (MHz)	Measure Level (dBuV/m)	Reading Level (dBuV)	Over Limit (dB)	Limit (dBuV/m)	Factor (dB)	Type
1		*	5622.522	68.601	30.862	-5.399	74.000	37.739	PK
2			5650.000	64.292	26.505	-9.708	74.000	37.787	PK
3			5700.000	64.211	26.319	-40.989	105.200	37.892	PK
4			5720.000	65.284	27.315	-45.516	110.800	37.970	PK
5			5725.000	69.101	31.111	-53.099	122.200	37.990	PK
6			5741.075	107.507	69.452	N/A	N/A	38.055	PK

Note: Measure Level (dBuV/m) = Reading Level (dBuV) + Factor (dB)

Factor (dB) = Cable Loss (dB) + Antenna Factor (dB/m)

Site: AC1	Time: 2016/07/13 - 20:21
Limit: FCC_Part15.407_RE(3m)	Engineer: Vince Yu
Probe: BBHA9120D_1-18GHz	Polarity: Horizontal
EUT: Personal Ground Station	Power: By Battery
Test Mode: Transmit by 802.11a at Channel 5825MHz	

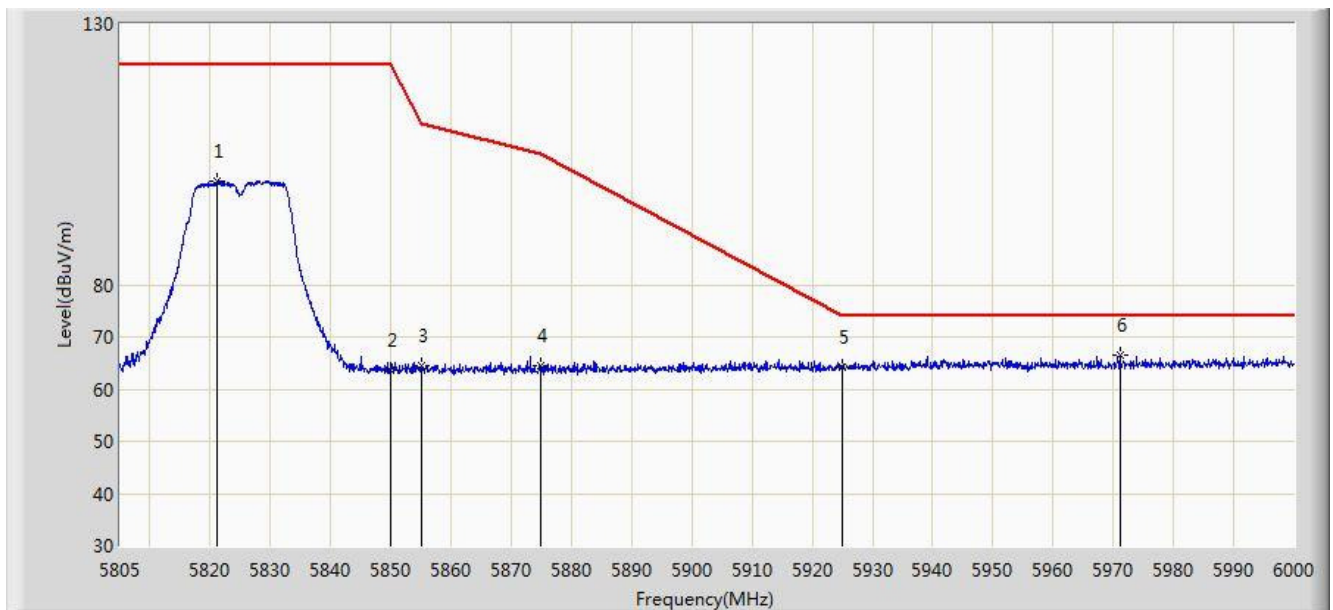

No	Flag	Mark	Frequency (MHz)	Measure Level (dBuV/m)	Reading Level (dBuV)	Over Limit (dB)	Limit (dBuV/m)	Factor (dB)	Type
1			5821.087	99.772	61.433	N/A	N/A	38.340	PK
2			5850.000	63.519	25.066	-58.681	122.200	38.454	PK
3			5855.000	64.405	25.940	-46.395	110.800	38.465	PK
4			5875.000	64.367	25.870	-40.833	105.200	38.497	PK
5			5925.000	64.081	25.548	-9.919	74.000	38.533	PK
6		*	5971.140	66.460	27.922	-7.540	74.000	38.538	PK

Note: Measure Level (dBuV/m) = Reading Level (dBuV) + Factor (dB)

Factor (dB) = Cable Loss (dB) + Antenna Factor (dB/m)

Site: AC1	Time: 2016/07/13 - 20:25
Limit: FCC_Part15.407_RE(3m)	Engineer: Vince Yu
Probe: BBHA9120D_1-18GHz	Polarity: Vertical
EUT: Personal Ground Station	Power: By Battery
Test Mode: Transmit by 802.11a at Channel 5825MHz	

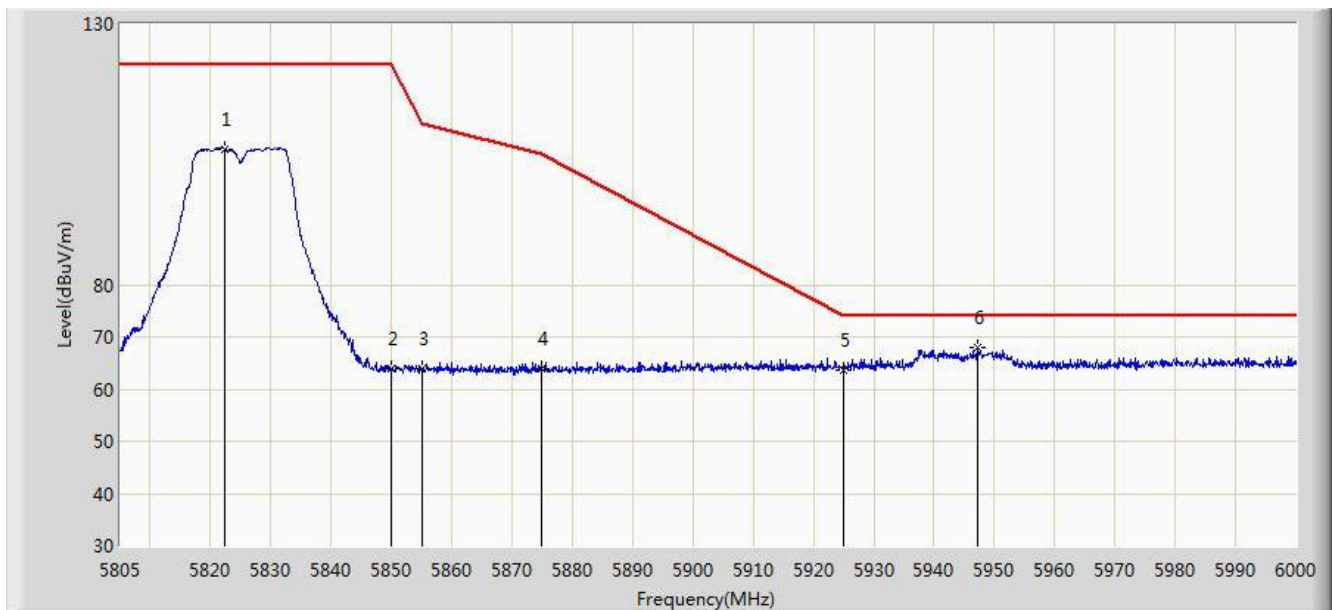

No	Flag	Mark	Frequency (MHz)	Measure Level (dBuV/m)	Reading Level (dBuV)	Over Limit (dB)	Limit (dBuV/m)	Factor (dB)	Type
1			5822.453	105.944	67.599	N/A	N/A	38.345	PK
2			5850.000	63.952	25.499	-58.248	122.200	38.454	PK
3			5855.000	63.915	25.450	-46.885	110.800	38.465	PK
4			5875.000	63.808	25.311	-41.392	105.200	38.497	PK
5			5925.000	63.707	25.174	-10.293	74.000	38.533	PK
6		*	5947.155	68.035	29.533	-5.965	74.000	38.502	PK

Note: Measure Level (dBuV/m) = Reading Level (dBuV) + Factor (dB)

Factor (dB) = Cable Loss (dB) + Antenna Factor (dB/m)

For IC requirement

Site: AC1	Time: 2016/07/19 - 17:14
Limit: FCC_Part15.209_RE(3m)	Engineer: Vince Yu
Probe: BBHA9120D_1-18GHz	Polarity: Horizontal
EUT: Personal Ground Station	Power: By Battery
Test Mode: Transmit by 802.11a at Channel 5745MHz	

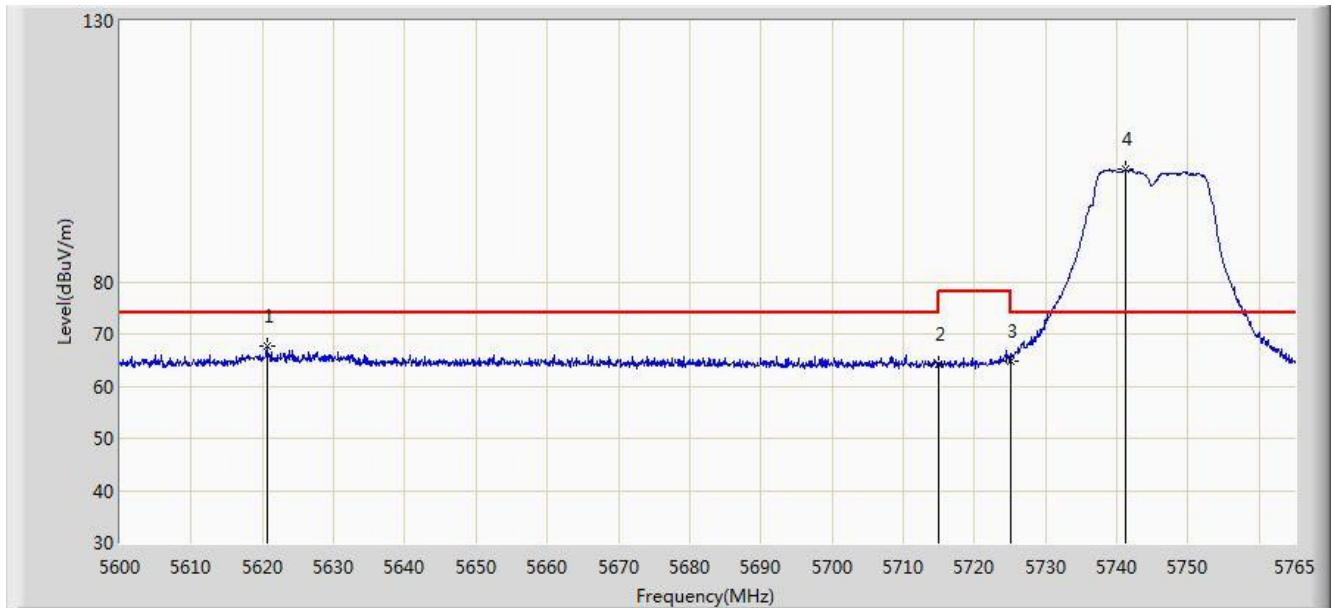

N o	Fl ag	M ar k	Frequency (MHz)	Measure Level (dBuV/m)	Reading Level (dBuV)	Over Limit (dB)	Limit (dBuV/m)	Factor (dB)	Type
1			5620.625	67.622	29.886	-6.378	74.000	37.735	PK
2			5715.000	64.214	31.947	-9.786	74.000	32.267	PK
3			5725.000	64.652	26.662	-13.548	78.200	37.990	PK
4		*	5741.322	101.466	63.410	N/A	N/A	38.056	PK

Note: Measure Level (dBuV/m) = Reading Level (dBuV) + Factor (dB)

Factor (dB) = Cable Loss (dB) + Antenna Factor (dB/m)

Site: AC1	Time: 2016/07/19 - 17:12
Limit: FCC_Part15.209_RE(3m)	Engineer: Vince Yu
Probe: BBHA9120D_1-18GHz	Polarity: Horizontal
EUT: Personal Ground Station	Power: By Battery
Test Mode: Transmit by 802.11a at Channel 5745MHz	

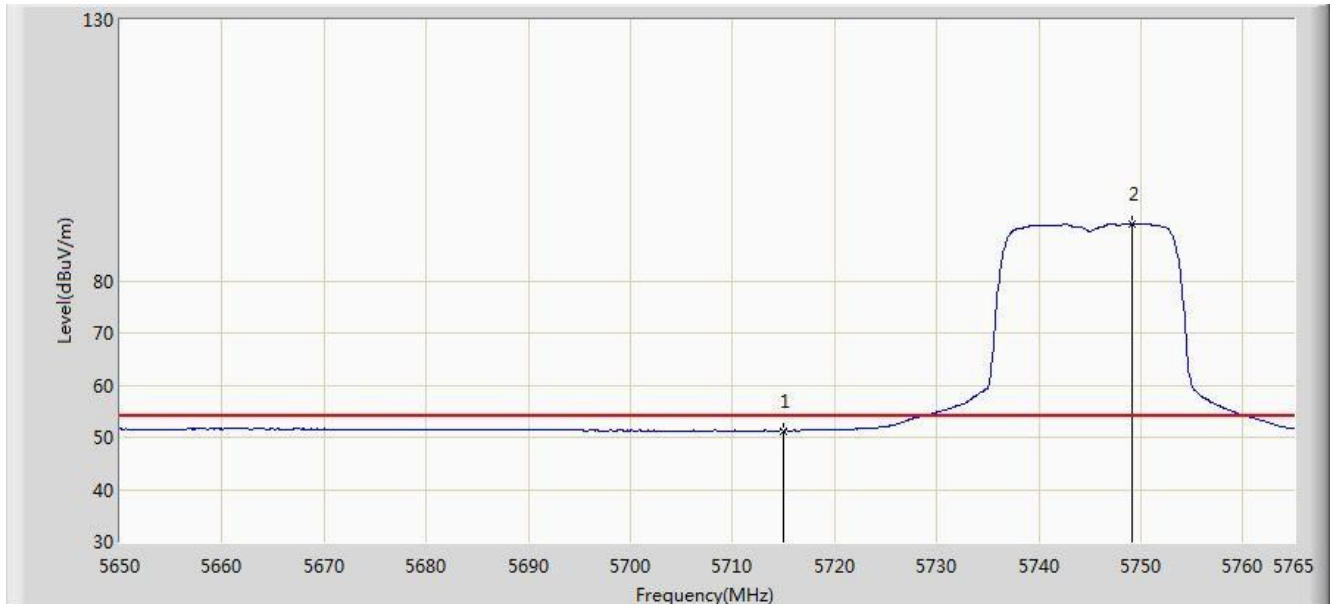

No	Flag	Mark	Frequency (MHz)	Measure Level (dBuV/m)	Reading Level (dBuV)	Over Limit (dB)	Limit (dBuV/m)	Factor (dB)	Type
1			5715.000	51.259	13.310	-2.741	54.000	37.949	AV
2		*	5749.078	90.933	52.842	N/A	N/A	38.091	AV

Note: Measure Level (dB μ V/m) = Reading Level (dB μ V) + Factor (dB)

Factor (dB) = Cable Loss (dB) + Antenna Factor (dB/m)

Site: AC1	Time: 2016/07/19 - 17:14
Limit: FCC_Part15.209_RE(3m)	Engineer: Vince Yu
Probe: BBHA9120D_1-18GHz	Polarity: Vertical
EUT: Personal Ground Station	Power: By Battery
Test Mode: Transmit by 802.11a at Channel 5745MHz	

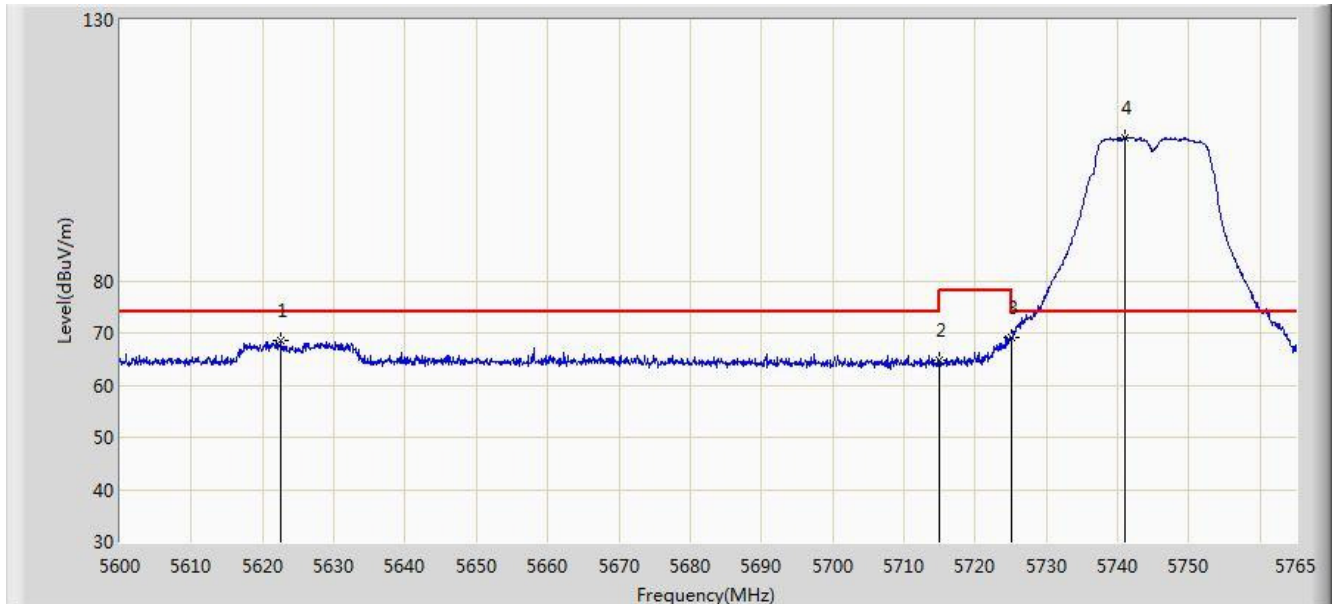

No	Flag	Mark	Frequency (MHz)	Measure Level (dBuV/m)	Reading Level (dBuV)	Over Limit (dB)	Limit (dBuV/m)	Factor (dB)	Type
1			5622.522	68.601	30.862	-5.399	74.000	37.739	PK
2			5715.000	64.780	32.513	-9.220	74.000	32.267	PK
3			5725.000	69.101	31.111	-9.099	78.200	37.990	PK
4		*	5741.075	107.507	69.452	N/A	N/A	38.055	PK

Note: Measure Level (dB μ V/m) = Reading Level (dB μ V) + Factor (dB)

Factor (dB) = Cable Loss (dB) + Antenna Factor (dB/m)

Site: AC1	Time: 2016/07/19 - 17:15
Limit: FCC_Part15.209_RE(3m)	Engineer: Vince Yu
Probe: BBHA9120D_1-18GHz	Polarity: Vertical
EUT: Personal Ground Station	Power: By Battery
Test Mode: Transmit by 802.11a at Channel 5745MHz	

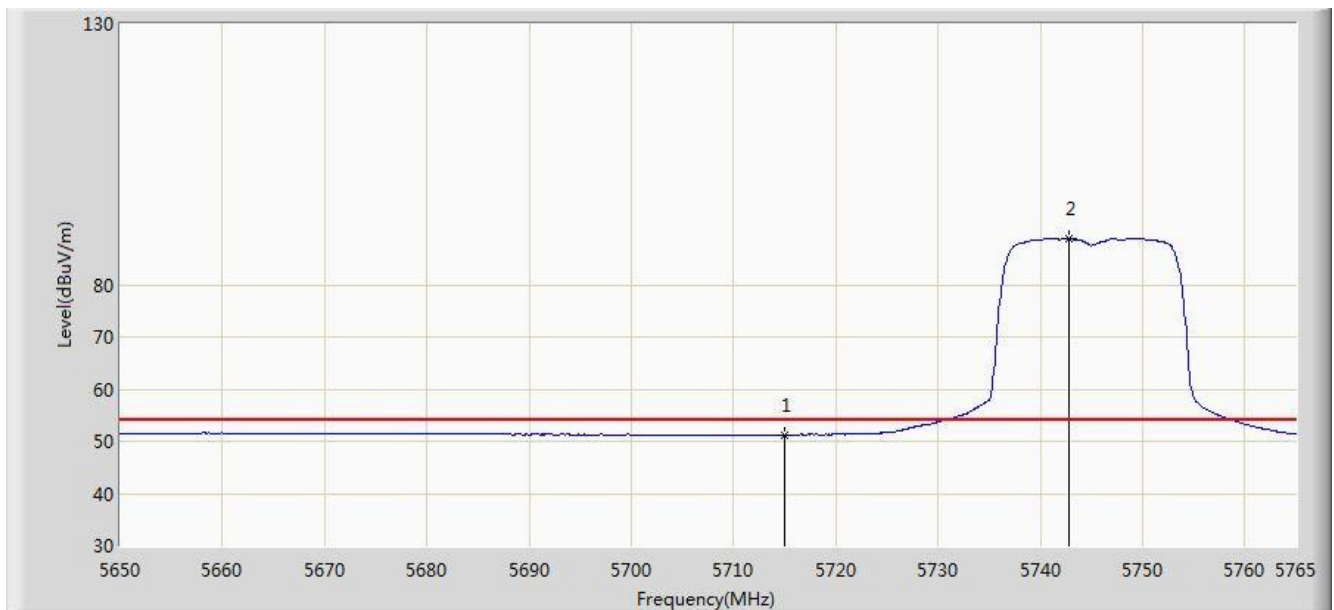

No	Flag	Mark	Frequency (MHz)	Measure Level (dBuV/m)	Reading Level (dBuV)	Over Limit (dB)	Limit (dBuV/m)	Factor (dB)	Type
1			5715.000	51.240	13.291	-2.760	54.000	37.949	AV
2		*	5742.808	88.887	50.826	N/A	N/A	38.062	AV

Note: Measure Level (dB μ V/m) = Reading Level (dB μ V) + Factor (dB)

Factor (dB) = Cable Loss (dB) + Antenna Factor (dB/m)

Site: AC1	Time: 2016/07/19 - 17:14
Limit: FCC_Part15.209_RE(3m)	Engineer: Vince Yu
Probe: BBHA9120D_1-18GHz	Polarity: Horizontal
EUT: Personal Ground Station	Power: By Battery
Test Mode: Transmit by 802.11a at Channel 5825MHz	

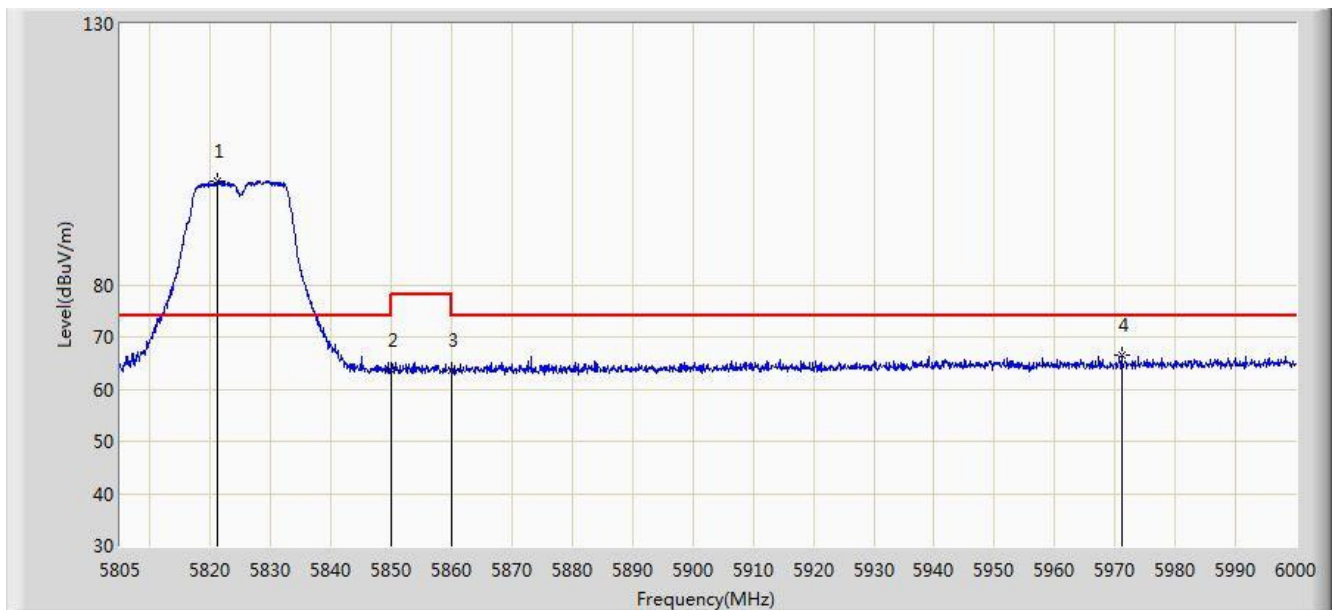

No	Flag	Mark	Frequency (MHz)	Measure Level (dBuV/m)	Reading Level (dBuV)	Over Limit (dB)	Limit (dBuV/m)	Factor (dB)	Type
1		*	5821.087	99.772	61.433	N/A	N/A	38.340	PK
2			5850.000	63.519	25.066	-14.681	78.200	38.454	PK
3			5860.000	63.574	30.856	-10.426	74.000	32.718	PK
4			5971.140	66.460	33.739	-7.540	74.000	32.721	PK

Note: Measure Level (dB μ V/m) = Reading Level (dB μ V) + Factor (dB)

Factor (dB) = Cable Loss (dB) + Antenna Factor (dB/m)

Site: AC1	Time: 2016/07/19 - 17:18
Limit: FCC_Part15.209_RE(3m)	Engineer: Vince Yu
Probe: BBHA9120D_1-18GHz	Polarity: Horizontal
EUT: Personal Ground Station	Power: By Battery
Test Mode: Transmit by 802.11a at Channel 5825MHz	

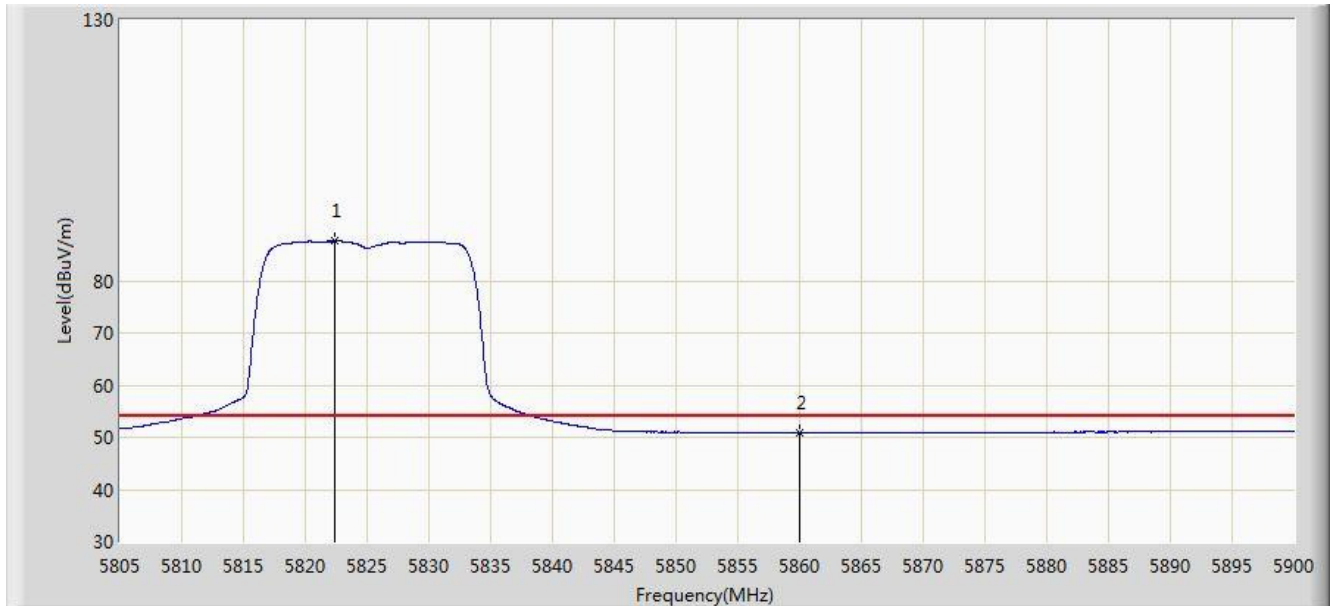

No	Flag	Mark	Frequency (MHz)	Measure Level (dBuV/m)	Reading Level (dBuV)	Over Limit (dB)	Limit (dBuV/m)	Factor (dB)	Type
1		*	5822.385	87.662	49.317	N/A	N/A	38.345	AV
2			5860.000	50.910	12.432	-3.090	54.000	38.478	AV

Note: Measure Level (dB μ V/m) = Reading Level (dB μ V) + Factor (dB)

Factor (dB) = Cable Loss (dB) + Antenna Factor (dB/m)

Site: AC1	Time: 2016/07/19 - 17:14
Limit: FCC_Part15.209_RE(3m)	Engineer: Vince Yu
Probe: BBHA9120D_1-18GHz	Polarity: Vertical
EUT: Personal Ground Station	Power: By Battery
Test Mode: Transmit by 802.11a at Channel 5825MHz	

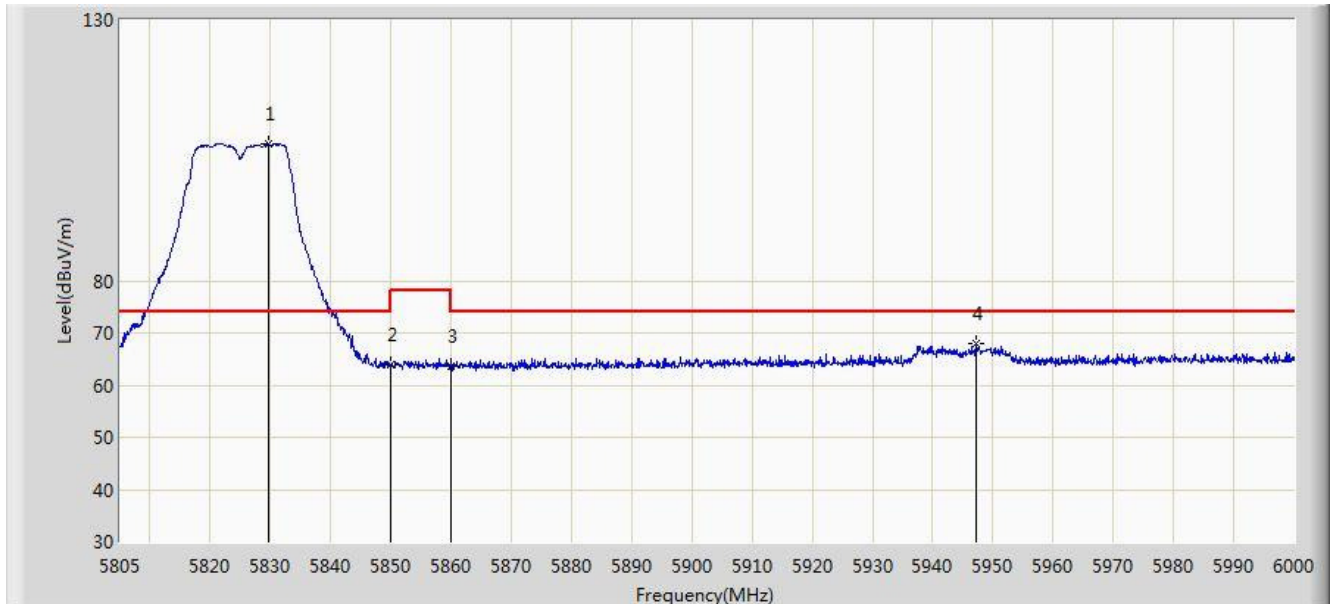

No	Flag	Mark	Frequency (MHz)	Measure Level (dBuV/m)	Reading Level (dBuV)	Over Limit (dB)	Limit (dBuV/m)	Factor (dB)	Type
1		*	5829.570	106.284	73.644	N/A	N/A	32.640	PK
2			5850.000	63.953	31.252	-14.247	78.200	32.701	PK
3			5860.000	63.651	30.933	-10.349	74.000	32.718	PK
4			5947.155	68.035	35.330	-5.965	74.000	32.705	PK

Note: Measure Level (dB μ V/m) = Reading Level (dB μ V) + Factor (dB)

Factor (dB) = Cable Loss (dB) + Antenna Factor (dB/m)

Site: AC1	Time: 2016/07/19 - 17:25
Limit: FCC_Part15.209_RE(3m)	Engineer: Vince Yu
Probe: BBHA9120D_1-18GHz	Polarity: Vertical
EUT: Personal Ground Station	Power: By Battery
Test Mode: Transmit by 802.11a at Channel 5825MHz	

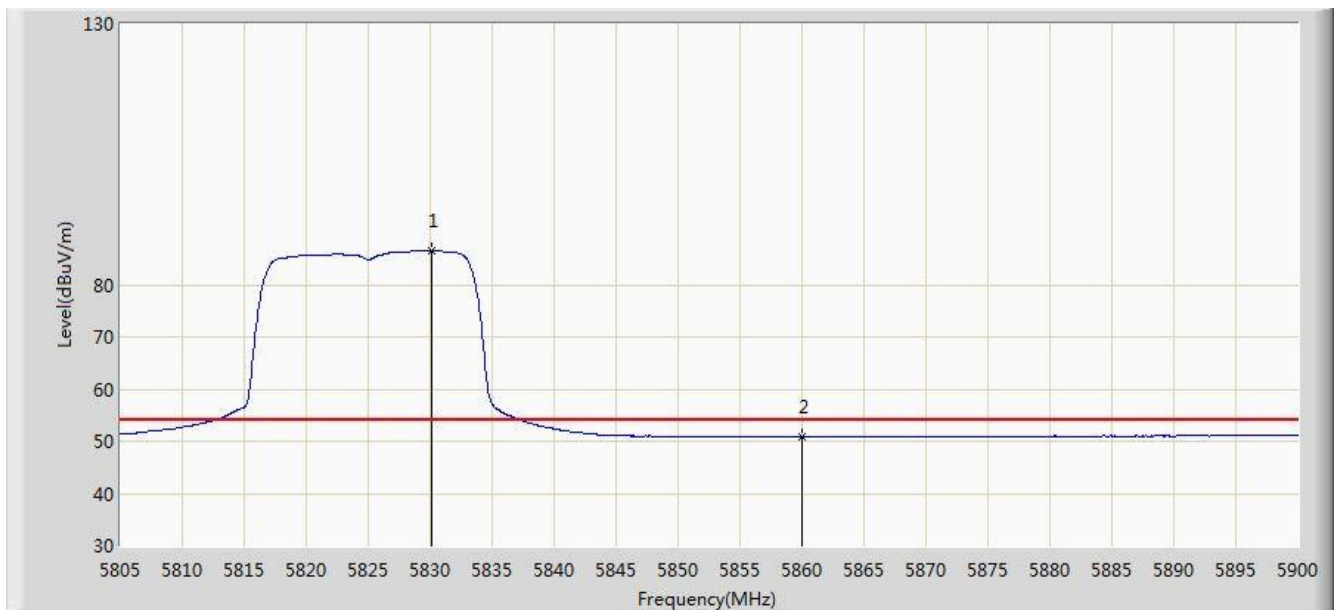

No	Flag	Mark	Frequency (MHz)	Measure Level (dBuV/m)	Reading Level (dBuV)	Over Limit (dB)	Limit (dBuV/m)	Factor (dB)	Type
1		*	5830.080	86.495	48.118	N/A	N/A	38.377	AV
2			5860.000	50.872	12.394	-3.128	54.000	38.478	AV

Note: Measure Level (dB μ V/m) = Reading Level (dB μ V) + Factor (dB)

Factor (dB) = Cable Loss (dB) + Antenna Factor (dB/m)

7.9. AC Conducted Emissions Measurement

7.9.1. Test Limit

FCC Part 15 Subpart C Paragraph 15.207 Limits		
Frequency (MHz)	QP (dBuV)	AV (dBuV)
0.15 - 0.50	66 - 56	56 – 46
0.50 - 5.0	56	46
5.0 - 30	60	50

Note 1: The lower limit shall apply at the transition frequencies.

Note 2: The limit decreases linearly with the logarithm of the frequency in the range 0.15MHz to 0.5MHz.

7.9.2. Test Setup

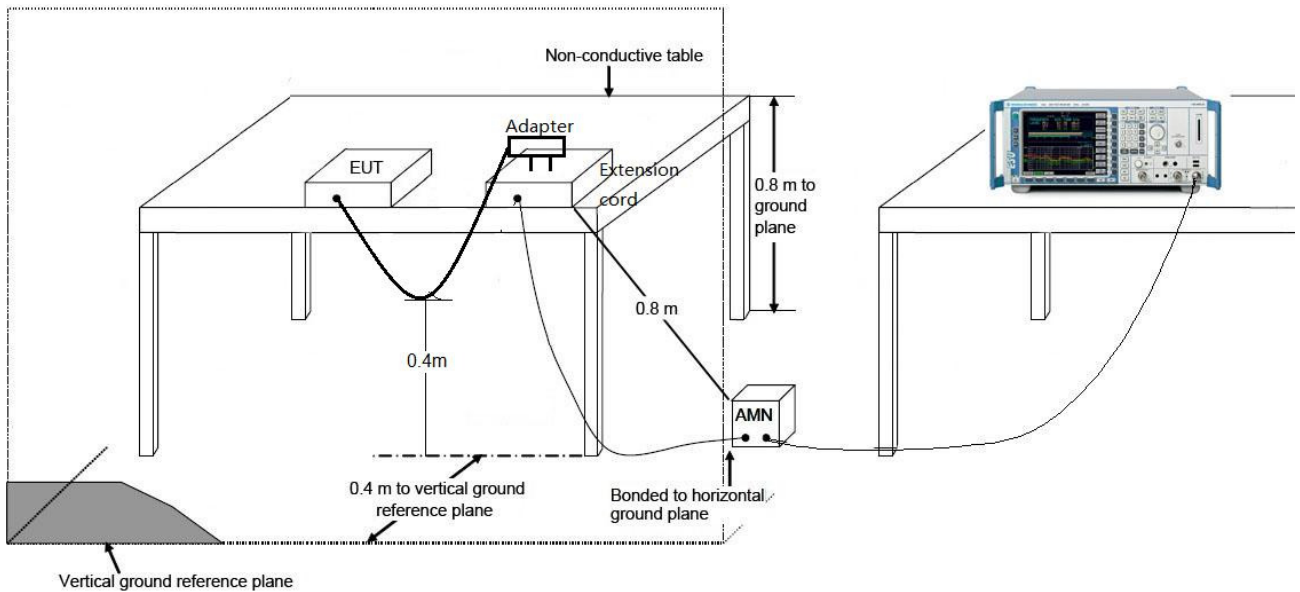

7.9.3. Test Result

Site: SR2	Time: 2016/07/19 - 16:06
Limit: FCC_Part15.207_CE_AC Power	Engineer: Milo Li
Probe: ENV216_101683_Filter On	Polarity: Line
EUT: Personal Ground Station	Power: AC 120V/60Hz
Note: Mode 1	

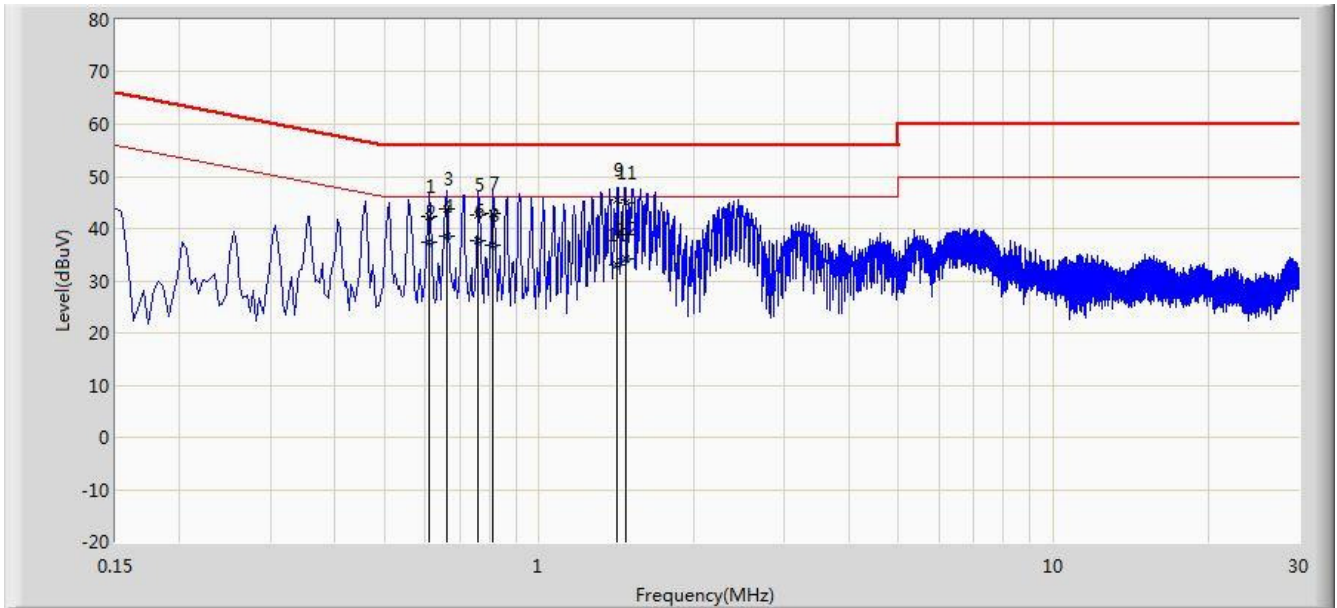

No	Flag	Mark	Frequency (MHz)	Measure Level (DBUV)	Reading Level (DBUV)	Over Limit (dB)	Limit (DBUV)	Factor (dB)	Type
1			0.610	42.339	32.229	-13.661	56.000	10.110	QP
2			0.610	37.383	27.273	-8.617	46.000	10.110	AV
3			0.662	43.876	33.793	-12.124	56.000	10.083	QP
4		*	0.662	38.497	28.414	-7.503	46.000	10.083	AV
5			0.762	42.640	32.609	-13.360	56.000	10.031	QP
6			0.762	37.691	27.660	-8.309	46.000	10.031	AV
7			0.814	43.002	32.998	-12.998	56.000	10.004	QP
8			0.814	36.951	26.947	-9.049	46.000	10.004	AV
9			1.418	45.565	35.673	-10.435	56.000	9.892	QP
10			1.418	33.187	23.295	-12.813	46.000	9.892	AV
11			1.478	44.921	35.031	-11.079	56.000	9.890	QP
12			1.478	34.182	24.292	-11.818	46.000	9.890	AV

Note: Measure Level (dB μ V) = Reading Level (dB μ V) + Factor (dB)

Factor (dB) = Cable Loss (dB) + LISN Factor (dB)

Site: SR2	Time: 2016/07/19 - 16:10
Limit: FCC_Part15.207_CE_AC Power	Engineer: Milo Li
Probe: ENV216_101683_Filter On	Polarity: Neutral
EUT: Personal Ground Station	Power: AC 120V/60Hz
Note: Mode 1	

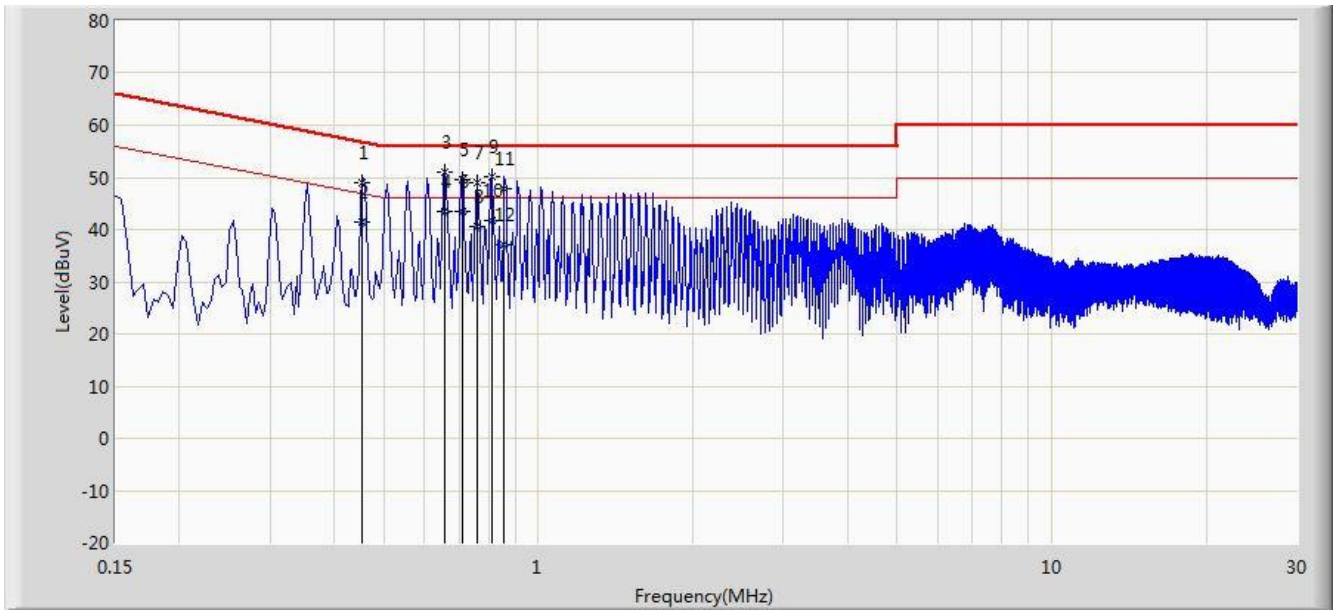

No	Flag	Mark	Frequency (MHz)	Measure Level (DBUV)	Reading Level (DBUV)	Over Limit (dB)	Limit (DBUV)	Factor (dB)	Type
1			0.454	49.101	38.948	-7.701	56.802	10.153	QP
2			0.454	41.388	31.235	-5.414	46.802	10.153	AV
3			0.658	50.873	40.775	-5.127	56.000	10.099	QP
4		*	0.658	43.433	33.334	-2.567	46.000	10.099	AV
5			0.710	49.548	39.478	-6.452	56.000	10.069	QP
6			0.710	43.358	33.289	-2.642	46.000	10.069	AV
7			0.758	49.057	39.014	-6.943	56.000	10.043	QP
8			0.758	40.472	30.429	-5.528	46.000	10.043	AV
9			0.810	50.022	40.009	-5.978	56.000	10.014	QP
10			0.810	41.860	31.846	-4.140	46.000	10.014	AV
11			0.858	47.877	37.889	-8.123	56.000	9.987	QP
12			0.858	37.077	27.090	-8.923	46.000	9.987	AV

Note: Measure Level (dB μ V) = Reading Level (dB μ V) + Factor (dB)

Factor (dB) = Cable Loss (dB) + LISN Factor (dB)

8. CONCLUSION

The data collected relate only the item(s) tested and show that the **Personal Ground Station FCC ID: 2ACS5-ST16P** is in compliance with Part 15E of the FCC Rules.

————— The End —————