

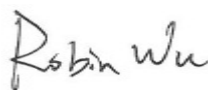



MEASUREMENT REPORT

FCC PART 15.247 / RSS-247 BLE

FCC ID: 2ACS5-EVO
IC: 11554B-EVO
APPLICANT: Yunee Technology Co., Limited
Application Type: Certification
Product: STEADIGAM eVo
Model No.: YUNSTD
Brand Name: YUNEEC
FCC Classification: Digital Transmission System (DTS)
FCC Rule Part(s): Part 15.247
IC Rule(s): RSS-247 Issue 1, RSS-GEN Issue 4
Test Procedure(s): ANSI C63.10-2013, KDB 558074 D01v03r05
Test Date: August 22 ~ September 23, 2016

Reviewed By : 
Manager : _____
(Robin Wu)

Approved By : 
CEO : _____
(Marlin Chen)



The test results relate only to the samples tested.

This equipment has been shown to be capable of compliance with the applicable technical standards as indicated in the measurement report and was tested in accordance with the measurement procedures specified in KDB 558074 D01v03r05. Test results reported herein relate only to the item(s) tested.

The test report shall not be reproduced except in full without the written approval of MRT Technology (Suzhou) Co., Ltd.

Revision History

Report No.	Version	Description	Issue Date	Note
1608RSU01901	Rev. 01	Initial report	09-23-2016	Invalid
1608RSU01901	Rev. 02	Revised the IC and FCC ID	10-12-2016	Invalid
1608RSU01901	Rev. 03	Revised the modulation type	10-17-2016	Valid

CONTENTS

Description	Page
1. INTRODUCTION	6
1.1. Scope	6
1.2. MRT Test Location	6
2. PRODUCT INFORMATION	7
2.1. Feature of Equipment under Test	7
2.2. Working Frequencies	7
2.3. Device Capabilities	8
2.4. Test Configuration	8
2.5. EMI Suppression Device(s)/Modifications	8
2.6. Labeling Requirements	8
2.7. Test Software	8
3. DESCRIPTION OF TEST	9
3.1. Evaluation Procedure	9
3.2. Radiated Emissions	10
4. ANTENNA REQUIREMENTS	11
5. TEST EQUIPMENT CALIBRATION DATE	12
6. MEASUREMENT UNCERTAINTY	13
7. TEST RESULT	14
7.1. Summary	14
7.2. 6dB Bandwidth Measurement	15
7.2.1. Test Limit	15
7.2.2. Test Procedure used	15
7.2.3. Test Setting	15
7.2.4. Test Setup	15
7.2.5. Test Result	16
7.3. Output Power Measurement	17
7.3.1. Test Limit	17
7.3.2. Test Procedure Used	17
7.3.3. Test Setting	17
7.3.4. Test Setup	17
7.3.5. Test Result of Output Power	18
7.4. Power Spectral Density Measurement	19
7.4.1. Test Limit	19

7.4.2.	Test Procedure Used	19
7.4.3.	Test Setting	19
7.4.4.	Test Setup.....	19
7.4.5.	Test Result.....	20
7.5.	Conducted Band Edge and Out-of-Band Emissions.....	21
7.5.1.	Test Limit	21
7.5.2.	Test Procedure Used	21
7.5.3.	Test Setting.....	21
7.5.4.	Test Setup.....	22
7.5.5.	Test Result.....	23
7.6.	Radiated Spurious Emission Measurement	25
7.6.1.	Test Limit	25
7.6.2.	Test Procedure Used	25
7.6.3.	Test Setting	25
7.6.4.	Test Setup.....	27
7.6.5.	Test Result.....	29
7.7.	Radiated Restricted Band Edge Measurement	38
7.7.1.	Test Result.....	38
7.8.	AC Conducted Emissions Measurement.....	46
7.8.1.	Test Limit	46
7.8.2.	Test Setup.....	46
7.8.3.	Test Result.....	46
8.	CONCLUSION.....	47

§2.1033 General Information

Applicant:	Yuneeec Technology Co., Limited
Applicant Address:	2/F Man Shung Industrial Building, 7 Lai Yip Street, Kwun Tong, Hong Kong
Manufacturer:	Yuneeec International (China) Co., Ltd.
Manufacturer Address:	No.388 East Zhengwei Road, Jinxi Town, Kunshan, Jiangsu 215324, China
Test Site:	MRT Technology (Suzhou) Co., Ltd
Test Site Address:	D8 Building, Youxin Industrial Park, No.2 Tian'edang Rd., Wuzhong Economic Development Zone, Suzhou, China
FCC Registration No.:	809388
IC Registration No.:	11384A
FCC Rule Part(s):	Part 15.247
IC Rule:	RSS-247 Issue 1, RSS-GEN Issue 4
Model No.:	YUNSTD
Test Device Serial No.:	N/A <input type="checkbox"/> Production <input checked="" type="checkbox"/> Pre-Production <input type="checkbox"/> Engineering
FCC Classification:	Digital Transmission System (DTS)

Test Facility / Accreditations

Measurements were performed at MRT Laboratory located in Tian'edang Rd., Suzhou, China.

- MRT facility is a FCC registered (MRT Reg. No. 809388) test facility with the site description report on file and has met all the requirements specified in Section 2.948 of the FCC Rules.
- MRT facility is an IC registered (MRT Reg. No. 11384A-1) test laboratory with the site description on file at Industry Canada.
- MRT facility is a VCCI registered (R-4179, G-814, C-4664, T-2206) test laboratory with the site description on file at VCCI Council.
- MRT Lab is accredited to ISO 17025 by the American Association for Laboratory Accreditation (A2LA) under the American Association for Laboratory Accreditation Program (A2LA Cert. No. 3628.01) in EMC, Telecommunications and Radio testing for FCC, Industry Canada, EU and TELEC Rules.



1. INTRODUCTION

1.1. Scope

Measurement and determination of electromagnetic emissions (EMC) of radio frequency devices including intentional and/or unintentional radiators for compliance with the technical rules and regulations of the Federal Communications Commission and the Industry Canada Certification and Engineering Bureau.

1.2. MRT Test Location

The map below shows the location of the MRT LABORATORY, its proximity to the Taihu Lake. These measurement tests were conducted at the MRT Technology (Suzhou) Co., Ltd. Facility located at D8 Building, Youxin Industrial Park, No.2 Tian'edang Rd., Wuzhong Economic Development Zone, Suzhou, China. The detailed description of the measurement facility was found to be in compliance with the requirements of § 2.948 according to ANSI C63.4-2009 on September 30, 2013.



2. PRODUCT INFORMATION

2.1. Feature of Equipment under Test

Product Name	STEADICAM eVo
Model No.	YUNSTD
Bluetooth Version	v4.0
Bluetooth Frequency	2402~2480MHz
Type of modulation	GFSK
Data Rate	1Mbps
Antenna Type	PCB Antenna
Antenna Gain	0dBi

2.2. Working Frequencies

Channel List for BLE

Channel	Frequency	Channel	Frequency	Channel	Frequency
00	2402 MHz	01	2404 MHz	02	2406 MHz
03	2408 MHz	04	2410 MHz	05	2412 MHz
06	2414 MHz	07	2416 MHz	08	2418 MHz
09	2420 MHz	10	2422 MHz	11	2424 MHz
12	2426 MHz	13	2428 MHz	14	2430 MHz
15	2432 MHz	16	2434 MHz	17	2436 MHz
18	2438 MHz	19	2440 MHz	20	2442 MHz
21	2444 MHz	22	2446 MHz	23	2448 MHz
24	2450 MHz	25	2452 MHz	26	2454 MHz
27	2456 MHz	28	2458 MHz	29	2460 MHz
30	2462 MHz	31	2464 MHz	32	2466 MHz
33	2468 MHz	34	2470 MHz	35	2472 MHz
36	2474 MHz	37	2476 MHz	38	2478 MHz
39	2480 MHz	--	--	--	--

2.3. Device Capabilities

This device contains the following capabilities:

Bluetooth v4.0

2.4. Test Configuration

The **STEADICAM eVo** was tested per the guidance of KDB 558074 D01v03r05. ANSI C63.10-2013 was used to reference the appropriate EUT setup for radiated spurious emissions testing and AC line conducted testing.

2.5. EMI Suppression Device(s)/Modifications

No EMI suppression device(s) were added and/or no modifications were made during testing.

2.6. Labeling Requirements

Per 2.1074 & 15.19; Docket 95-19

The label shall be permanently affixed at a conspicuous location on the device; instruction manual or pamphlet supplied to the user and be readily visible to the purchaser at the time of purchase. However, when the device is so small wherein placement of the label with specified statement is not practical, only the FCC ID must be displayed on the device per Section 15.19(a)(5). Please see attachment for FCC ID label and label location.

2.7. Test Software

The test utility software used during testing was "nRFgostudio.exe".

3. DESCRIPTION OF TEST

3.1. Evaluation Procedure

The measurement procedures described in the American National Standard for Testing Unlicensed Wireless Devices (ANSI C63.10-2013), and the guidance provided in KDB 558074 D01v03r05 were used in the measurement of the **STEADICAM eVo**.

Deviation from measurement procedure.....None

3.2. Radiated Emissions

The radiated test facilities consisted of an indoor 3 meter semi-anechoic chamber used for final measurements and exploratory measurements, when necessary. The measurement area is contained within the semi-anechoic chamber which is shielded from any ambient interference. For measurements above 1GHz absorbers are arranged on the floor between the turn table and the Antenna mast in such a way so as to maximize the reduction of reflections. For measurements below 1GHz, the absorbers are removed. A MF Model 210SS turntable is used for radiated measurement. It is a continuously rotatable, remote controlled, metallic turntable and 2 meters (6.56 ft.) in diameter. The turn table is flush with the raised floor of the chamber in order to maintain its function as a ground plane. An 80cm high PVC support structure is placed on top of the turntable. For all measurements, the spectrum was scanned through all EUT azimuths and from 1 to 4 meter receive Antenna height using a broadband Antenna from 30MHz up to the upper frequency shown in 15.33(b)(1) depending on the highest frequency generated or used in the device or on which the device operates or tunes. For frequencies above 1GHz, linearly polarized double ridge horn Antennas were used. For frequencies below 30MHz, a calibrated loop Antenna was used. When exploratory measurements were necessary, they were performed at 1 meter test distance inside the semi-anechoic chamber using broadband Antennas, broadband amplifiers, and spectrum analyzers to determine the frequencies and modes producing the maximum emissions. Sufficient time for the EUT, support equipment, and test equipment was allowed in order for them to warm up to their normal operating condition. The test set-up for frequencies below 1GHz was placed on top of the 0.8 meter high, 1 x 1.5 meter table; and test set-up for frequencies 1-40GHz was placed on top of the 1.5 meter high, 1 x 1.5 meter table. The EUT, support equipment, and interconnecting cables were arranged and manipulated to maximize each emission. Appropriate precaution was taken to ensure that all emissions from the EUT were maximized and investigated. The system configuration, clock speed, mode of operation or video resolution, if applicable, turntable azimuth, and receive Antenna height was noted for each frequency found.

Final measurements were made in the semi-anechoic chamber using calibrated, linearly polarized broadband and horn Antennas. The test setup was configured to the setup that produced the worst case emissions. The spectrum analyzer was set to investigate all frequencies required for testing to compare the highest radiated disturbances with respect to the specified limits. The turntable containing the EUT was rotated through 360 degrees and the height of the receive Antenna was varied 1 to 4 meters and stopped at the azimuth and height producing the maximum emission. Each emission was maximized by changing the orientation of the EUT through three orthogonal planes and changing the polarity of the receive Antenna, whichever produced the worst-case emissions. According to 3dB Beam-Width of horn Antenna, the horn Antenna should be always directed to the EUT when rising height.

4. ANTENNA REQUIREMENTS

Excerpt from §15.203 of the FCC Rules/Regulations:

“An intentional radiator antenna shall be designed to ensure that no antenna other than that furnished by the responsible party can be used with the device. The use of a permanently attached antenna or of an antenna that uses a unique coupling to the intentional radiator shall be considered sufficient to comply with the provisions of this section.”

- The antenna of the **STEADICAM eVo** is **permanently attached**.
- There are no provisions for connection to an external antenna.

Conclusion:

The **STEADICAM eVo** unit complies with the requirement of §15.203.

5. TEST EQUIPMENT CALIBRATION DATE

Radiated Emissions – AC1

Instrument	Manufacturer	Type No.	Asset No.	Cali. Interval	Cali. Due Date
EXA Signal Analyzer	Agilent	N9010A	MRTSUE06124	1 year	2017/06/23
EMI Test Receiver	R&S	ESR7	MRTSUE06001	1 year	2016/11/03
Preamplifier	Agilent	83017A	MRTSUE06076	1 year	2017/03/29
Loop Antenna	Schwarzbeck	FMZB1519	MRTSUE06025	1 year	2016/12/14
TRILOG Antenna	Schwarzbeck	VULB9162	MRTSUE06022	1 year	2016/11/07
Broad-Band Horn Antenna	Schwarzbeck	BBHA9120D	MRTSUE06023	1 year	2016/11/07
Broadband Horn Antenna	Schwarzbeck	BBHA9170	MRTSUE06024	1 year	2017/01/04
Digital Thermometer & Hygrometer	Minggao	N/A	MRTSUE06170	1 year	2016/11/30
RF Cable	HUBER+SUHNER	Cable 01	MRTSUE06055-1	1 year	2017/03/29
RF Cable	HUBER+SUHNER	Cable 02	MRTSUE06055-2	1 year	2017/03/29
Anechoic Chamber	TDK	Chamber-AC1	MRTSUE06212	1 year	2017/05/10

Conducted Test Equipment – TR3

Instrument	Manufacturer	Type No.	Asset No.	Cali. Interval	Cali. Due Date
Spectrum Analyzer	Agilent	N9020A	MRTSUE06106	1 year	2017/05/08
USB Wideband Power Sensor	Boonton	55006	MRTSUE06109	1 year	2017/05/08
RF Cable	HUBER+SUHNER	Cable 03	MRTSUE06055-3	1 year	2017/03/29
Attenuator	Woken	WATT-218FS-15	MRTSUE06220	1 year	2017/03/29
DC Block	Woken	00900A1A2A101A	MRTSUE06221	1 year	2017/03/29
Temperature/Humidity Meter	Yuhuaze	HTC-2	MRTSUE06180	1 year	2016/12/20

Software	Version	Function
e3	V8.3.5	EMI Test Software

6. MEASUREMENT UNCERTAINTY

Where relevant, the following test uncertainty levels have been estimated for tests performed on the EUT as specified in CISPR 16-4-2. This uncertainty represents an expanded uncertainty expressed at approximately the 95% confidence level using a coverage factor of $k = 2$.

Radiated Emission Measurement - AC1
Measuring Uncertainty for a Level of Confidence of 95% ($U=2Uc(y)$): 9kHz ~ 1GHz: 4.18dB 1GHz ~ 25GHz: 4.76dB
Spurious Emissions, Conducted - TR3
Measuring Uncertainty for a Level of Confidence of 95% ($U=2Uc(y)$): 0.78dB
Output Power - TR3
Measuring Uncertainty for a Level of Confidence of 95% ($U=2Uc(y)$): 1.13dB
Power Spectrum Density - TR3
Measuring Uncertainty for a Level of Confidence of 95% ($U=2Uc(y)$): 1.15dB
Occupied Bandwidth - TR3
Measuring Uncertainty for a Level of Confidence of 95% ($U=2Uc(y)$): 0.28%

7. TEST RESULT

7.1. Summary

Company Name: Yunee Technology Co., Limited
FCC ID: 2ACS5-EVO
IC: 1154B-EVO
Data Rate(s) Tested: 1Mbps(GFSK) (BLE)

FCC Part Section(s)	RSS Section(s)	Test Description	Test Limit	Test Condition	Test Result	Reference
15.247(a)(2)	RSS-247 [5.2]	6dB Bandwidth	$\geq 500\text{kHz}$	Conducted	Pass	Section 7.2
15.247(b)(3)	RSS-247 [5.4(4)]	Output Power	$\leq 1\text{Watt}$ & $\text{EIRP} \leq 4\text{Watt}$		Pass	Section 7.3
15.247(e)	RSS-247 [5.2]	Power Spectral Density	$\leq 8\text{dBm} / 3\text{kHz}$		Pass	Section 7.4
15.247(d)	RSS-247 [5.5]	Band Edge / Out-of-Band Emissions	$\geq 20\text{dBc(Peak)}$		Pass	Section 7.5
15.205 15.209	RSS-247 [5.5]	General Field Strength Limits (Restricted Bands and Radiated Emission Limits)	Emissions in restricted bands must meet the radiated limits detailed in 15.209	Radiated	Pass	Section 7.6&7.7

Notes:

- 1) All modes of operation and data rates were investigated. For radiated emission test, every axis (X, Y, Z) was also verified. The test results shown in the following sections represent the worst case emissions.
- 2) The analyzer plots shown in this section were all taken with a correction table loaded into the analyzer. The correction table was used to account for the losses of the cables and attenuators used as part of the system to connect the EUT to the analyzer at all frequencies of interest.
- 3) All antenna port conducted emissions testing was performed on a test bench with the antenna port of the EUT connected to the spectrum analyzer through calibrated cables and attenuators.

7.2. 6dB Bandwidth Measurement

7.2.1. Test Limit

The minimum 6dB bandwidth shall be at least 500 kHz.

7.2.2. Test Procedure used

KDB 558074 D01v03r05 - Section 8.2 Option 2

7.2.3. Test Setting

1. The Spectrum's automatic bandwidth measurement capability was used to perform the 6dB bandwidth measurement. The "X" dB bandwidth parameter was set to $X = 6$. The bandwidth measurement was not influenced by any intermediate power nulls in the fundamental emission.
2. Set RBW = 100 kHz
3. VBW $\geq 3 \times$ RBW
4. Detector = Peak
5. Trace mode = max hold
6. Sweep = auto couple
7. Allow the trace was allowed to stabilize

7.2.4. Test Setup

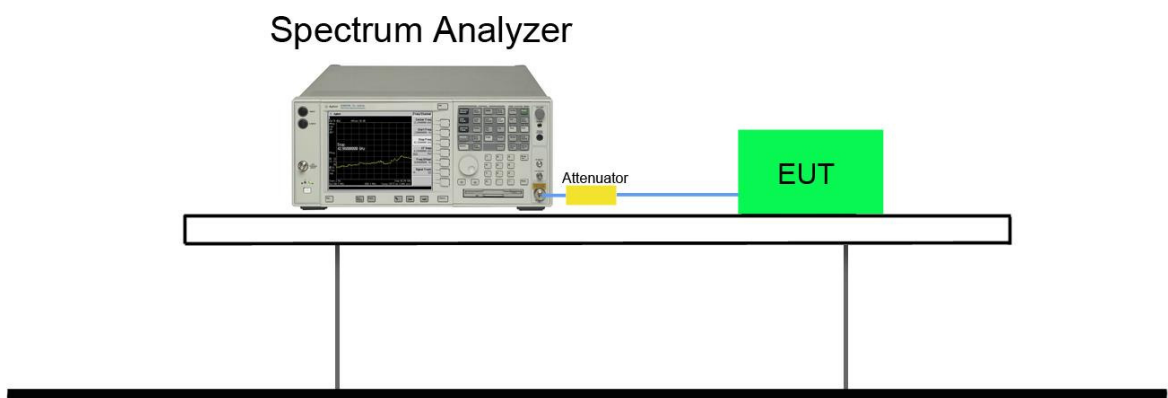

7.2.5. Test Result

Test Mode	Data Rate (Mbps)	Channel No.	Frequency (MHz)	6dB Bandwidth (kHz)	Limit (kHz)	99% Bandwidth (MHz)	Result
BLE	1	00	2402	694.8	≥ 500	1.078	Pass
BLE	1	19	2440	694.7	≥ 500	1.077	Pass
BLE	1	39	2480	695.8	≥ 500	1.078	Pass

6dB Bandwidth

Channel 00 (2402MHz)

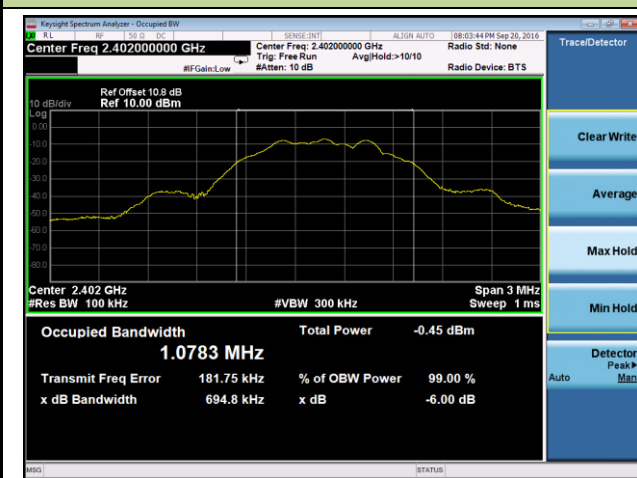

Channel 19 (2440MHz)

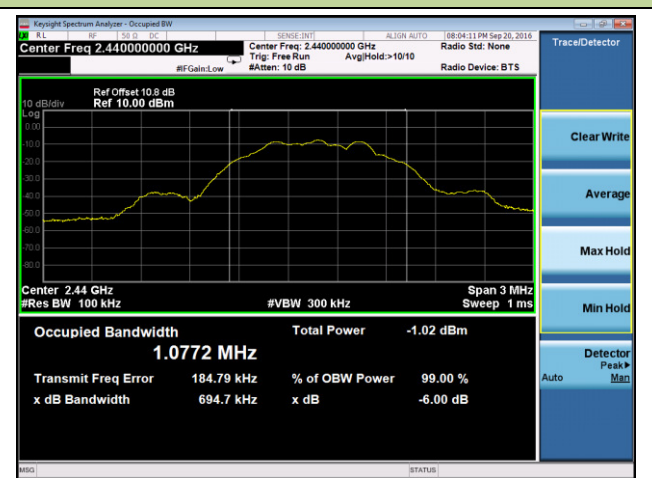

Channel 39 (2480MHz)

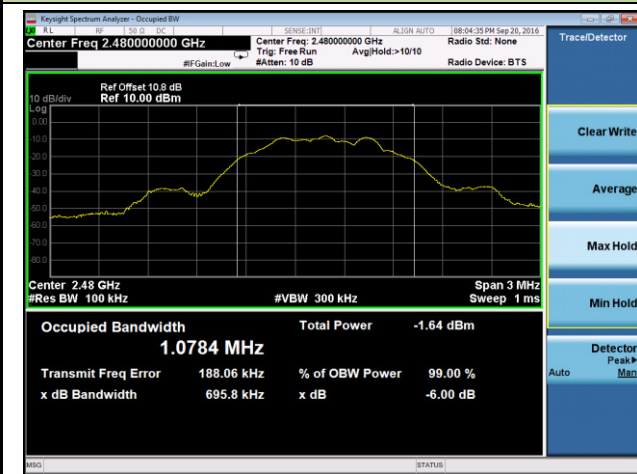

7.3. Output Power Measurement

7.3.1. Test Limit

The maximum out power shall be less 1 Watt (30dBm).

7.3.2. Test Procedure Used

KDB 558074 D01v03r05 - Section 9.1.2 PKPM1 - Peak Power Method

7.3.3. Test Setting

Method PKPM1 (Peak Power Measurement of Signals with DTS BW \leq 50MHz)

Peak power measurements were performed only when the EUT was transmitting at its maximum power control level using a broadband power meter with a pulse sensor. The pulse sensor employs a VBW = 50MHz so this method was only used for signals whose DTS bandwidth was less than or equal to 50MHz.

7.3.4. Test Setup

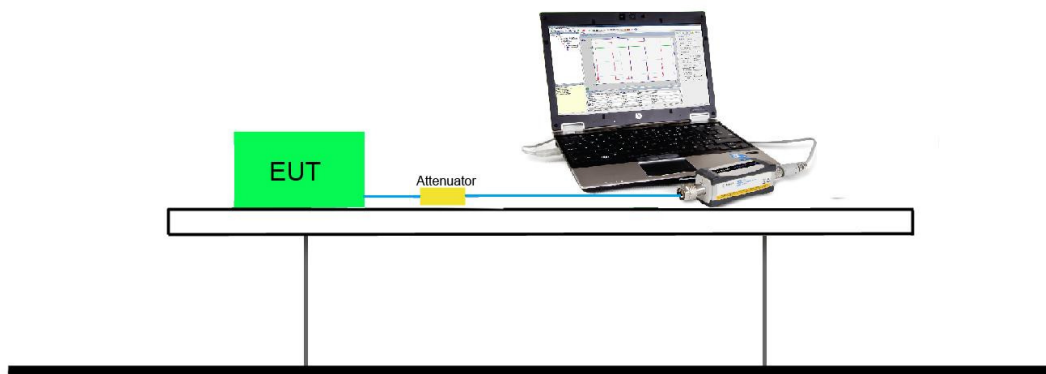

7.3.5. Test Result of Output Power

Test Mode	Data Rate (Mbps)	Channel No.	Frequency (MHz)	Peak Output Power (dBm)	Limit (dBm)	E.I.R.P (dBm)	Limit (dBm)	Result
BLE	1	00	2402	-5.63	≤ 30	-5.63	≤ 36	Pass
BLE	1	19	2440	-6.21	≤ 30	-6.21	≤ 36	Pass
BLE	1	39	2480	-6.37	≤ 30	-6.37	≤ 36	Pass

Note: E.I.R.P. (dBm) = Peak Output Power (dBm) + Antenna Gain (dBi).

7.4. Power Spectral Density Measurement

7.4.1. Test Limit

The maximum permissible power spectral density is 8dBm in any 3 kHz band.

7.4.2. Test Procedure Used

KDB 558074 D01v03r05 - Section 10.2 Method PKPSD

7.4.3. Test Setting

1. Analyzer was set to the center frequency of the DTS channel under investigation
2. Span = 1.5 times the DTS channel bandwidth
3. RBW = 3kHz
4. VBW = 10kHz
5. Detector = peak
6. Sweep time = auto couple
7. Trace mode = max hold
8. Trace was allowed to stabilize

7.4.4. Test Setup

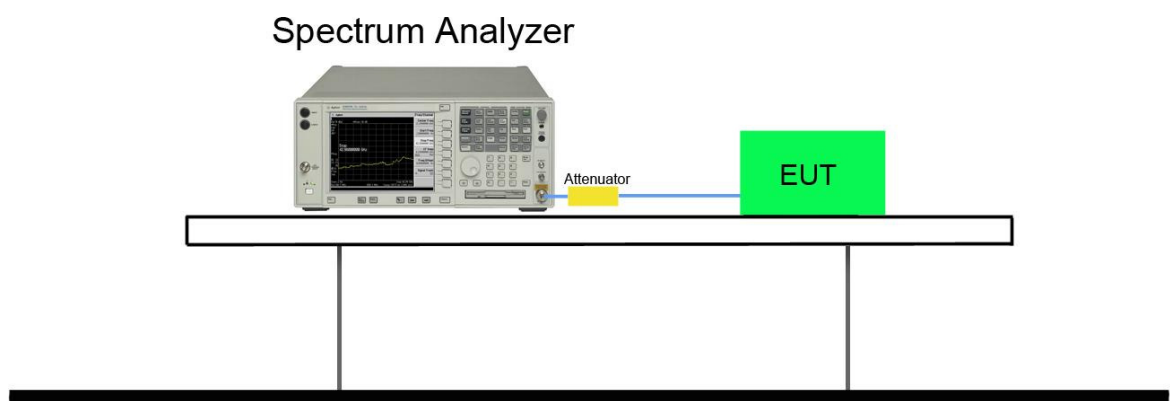

7.4.5. Test Result

Test Mode	Data Rate (Mbps)	Channel No.	Frequency (MHz)	PSD Result (dBm / 3kHz)	Limit (dBm / 3kHz)	Result
BLE	1	00	2402	-25.3	≤ 8	Pass
BLE	1	19	2440	-25.8	≤ 8	Pass
BLE	1	39	2480	-26.3	≤ 8	Pass

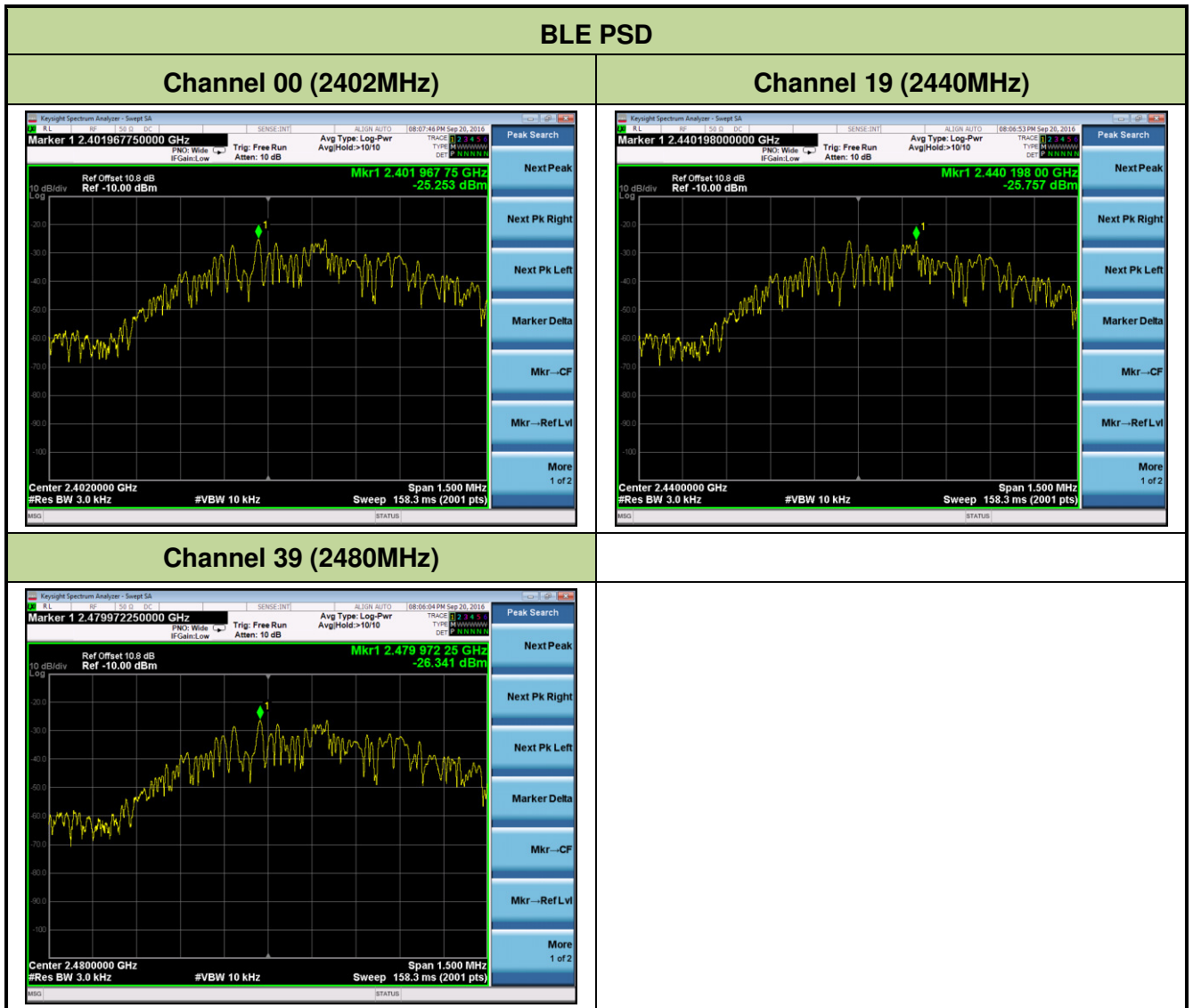

7.5. Conducted Band Edge and Out-of-Band Emissions

7.5.1. Test Limit

The limit for out-of-band spurious emissions at the band edge is 20dB below the fundamental emission level, as determined from the in-band power measurement of the DTS channel performed in a 100kHz bandwidth per the PSD procedure.

7.5.2. Test Procedure Used

KDB 558074 D01v03r05 - Section 11.2 & Section 11.3

7.5.3. Test Setting

1. Reference level measurement

- (a) Set instrument center frequency to DTS channel center frequency
- (b) Set the span to ≥ 1.5 times the DTS bandwidth
- (c) Set the RBW = 100 kHz
- (d) Set the VBW $\geq 3 \times$ RBW
- (e) Detector = peak
- (f) Sweep time = auto couple
- (g) Trace mode = max hold
- (h) Allow trace to fully stabilize

2. Emission level measurement

- (a) Set the center frequency and span to encompass frequency range to be measured
- (b) RBW = 100kHz
- (c) VBW = 300kHz
- (d) Detector = Peak
- (e) Number of sweep points $\geq 2 \times$ Span/RBW
- (f) Trace mode = max hold
- (g) Sweep time = auto couple
- (h) The trace was allowed to stabilize

7.5.4. Test Setup

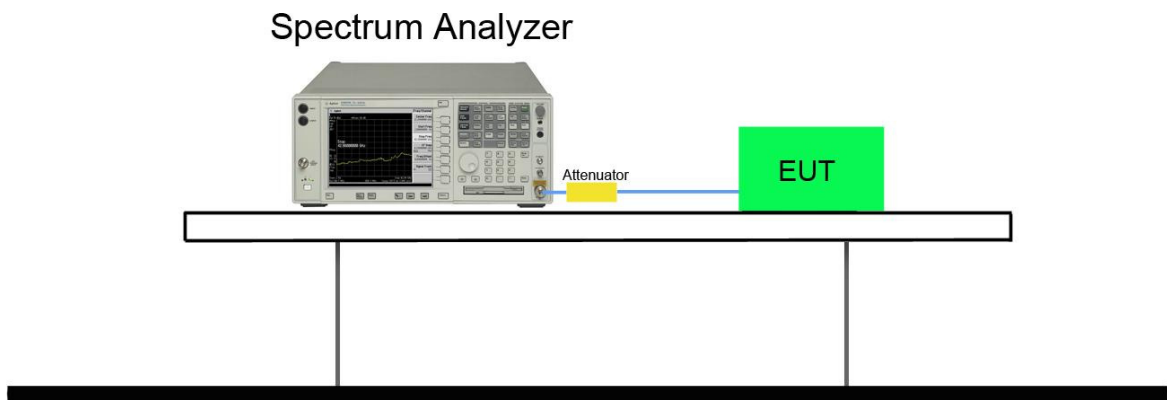

7.5.5. Test Result

Test Mode	Data Rate (Mbps)	Channel No.	Frequency (MHz)	Limit	Result
BLE	1	00	2402	20dBc	Pass
BLE	1	19	2440	20dBc	Pass
BLE	1	39	2480	20dBc	Pass

BLE Out-of-Band Emissions

Channel 00 (2402MHz)

100kHz PSD reference Level



Low Band Edge



Spurious Emission 30MHz ~ 25GHz

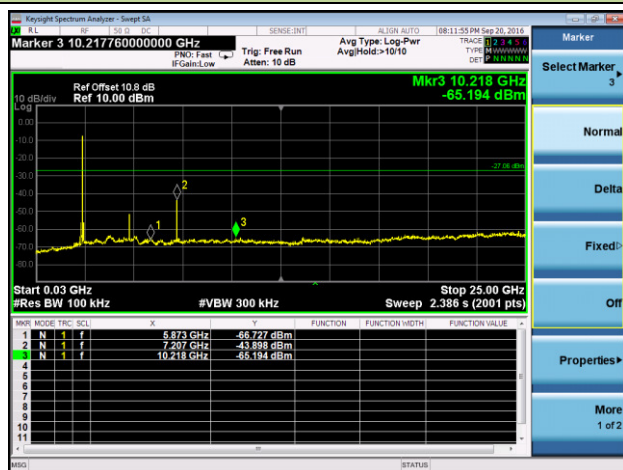

Channel 19 (2440MHz)

100kHz PSD reference Level



Spurious Emission 30MHz ~ 25GHz

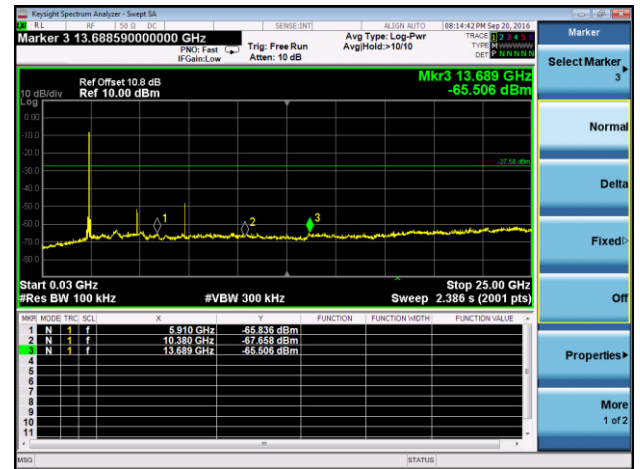

Channel 39 (2480MHz)

100kHz PSD reference Level



High Band Edge



Spurious Emission 30MHz ~ 25GHz

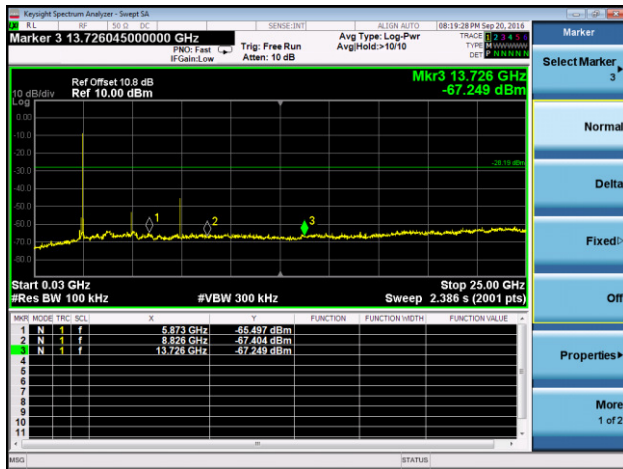

7.6. Radiated Spurious Emission Measurement

7.6.1. Test Limit

All out of band emissions appearing in a restricted band as specified in Section 15.205 of the Title 47 CFR must not exceed the limits shown in Table per Section 15.209.

FCC Part 15 Subpart C Paragraph 15.209		
Frequency [MHz]	Field Strength [$\mu\text{V/m}$]	Measured Distance [Meters]
0.009 – 0.490	2400/F (kHz)	300
0.490 – 1.705	24000/F (kHz)	30
1.705 - 30	30	30
30 - 88	100	3
88 - 216	150	3
216 - 960	200	3
Above 960	500	3

7.6.2. Test Procedure Used

KDB 558074 D01v03r05 - Section 12.2.3 (quasi-peak measurements)

KDB 558074 D01v03r05 - Section 12.2.4 (peak power measurements)

KDB 558074 D01v03r05 - Section 12.2.5 (average power measurements)

7.6.3. Test Setting

Peak Field Strength Measurements per Section 12.2.4 of KDB 558074 D01v03r05

1. Analyzer center frequency was set to the frequency of the radiated spurious emission of interest
2. RBW = as specified in Table 1
3. VBW = 3MHz
4. Detector = peak
5. Sweep time = auto couple

6. Trace mode = max hold
7. Trace was allowed to stabilize

Table 1 - RBW as a function of frequency

Frequency	RBW
9 ~ 150 kHz	200 ~ 300 Hz
0.15 ~ 30 MHz	9 ~ 10 kHz
30 ~ 1000 MHz	100 ~ 120 kHz
> 1000 MHz	1 MHz

Average Field Strength Measurements per Section 12.2.4 of KDB 558074 D01v03r05

1. Analyzer center frequency was set to the frequency of the radiated spurious emission of interest
2. RBW = 1MHz
3. VBW $\geq 1/T$
4. De As an alternative, the instrument may be set to linear detector mode. Ensure that video filtering is applied in linear voltage domain (rather than in a log or dB domain). Some instruments require linear display mode in order to accomplish this. Others have a setting for Average-VBW Type, which can be set to "Voltage" regardless of the display mode
5. Detector = Peak
6. Sweep time = auto
7. Trace mode = max hold
8. Allow max hold to run for at least 50 times (1/duty cycle) traces

7.6.4. Test Setup

9kHz ~ 30MHz Test Setup:

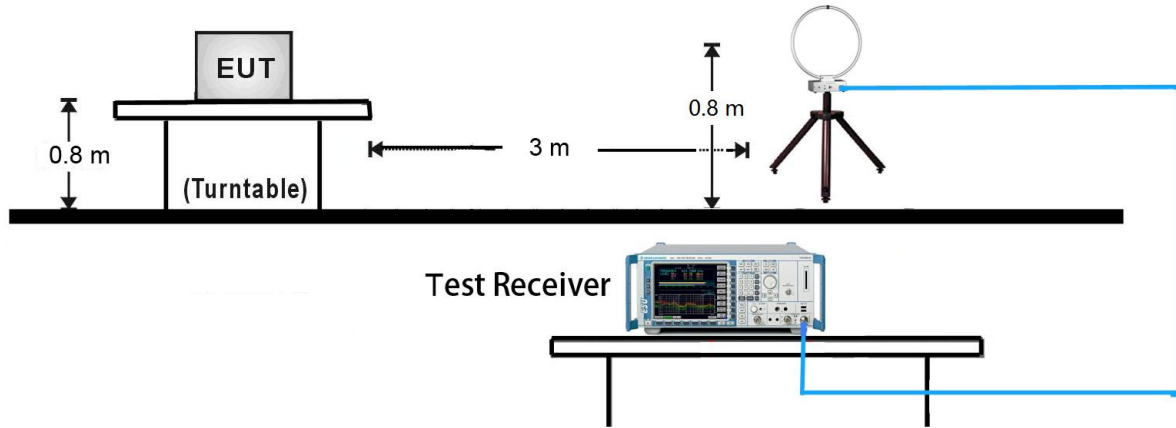

30MHz ~ 1GHz Test Setup:

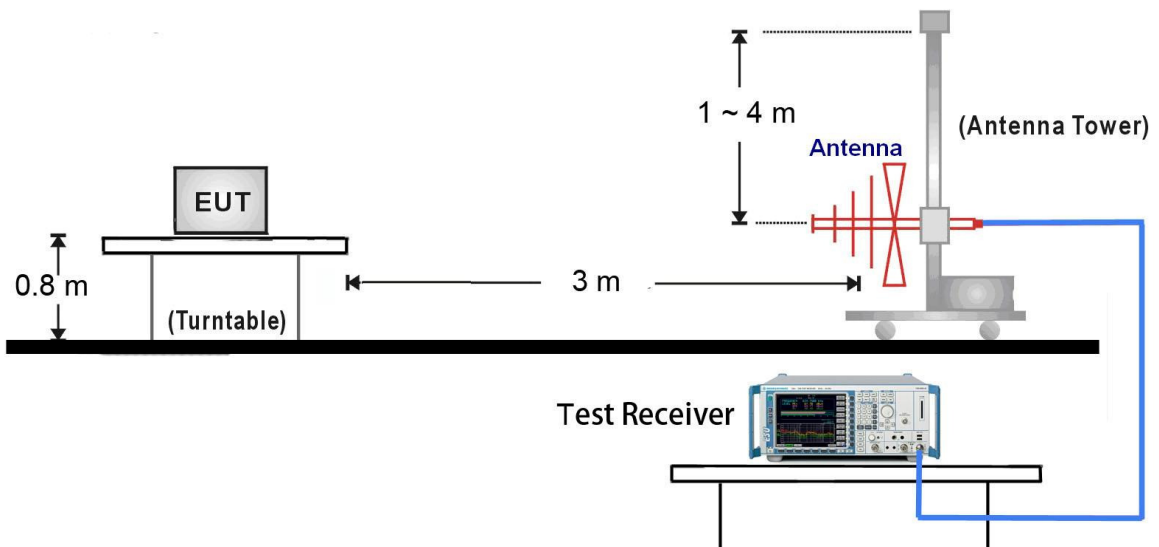

1GHz ~ 18GHz Test Setup:

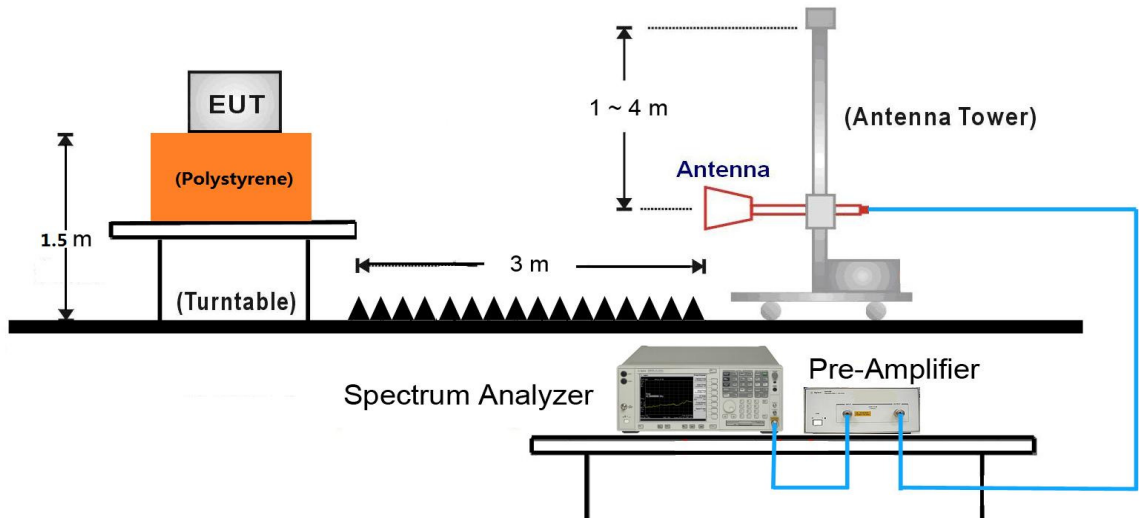

18GHz ~ 25GHz Test Setup:

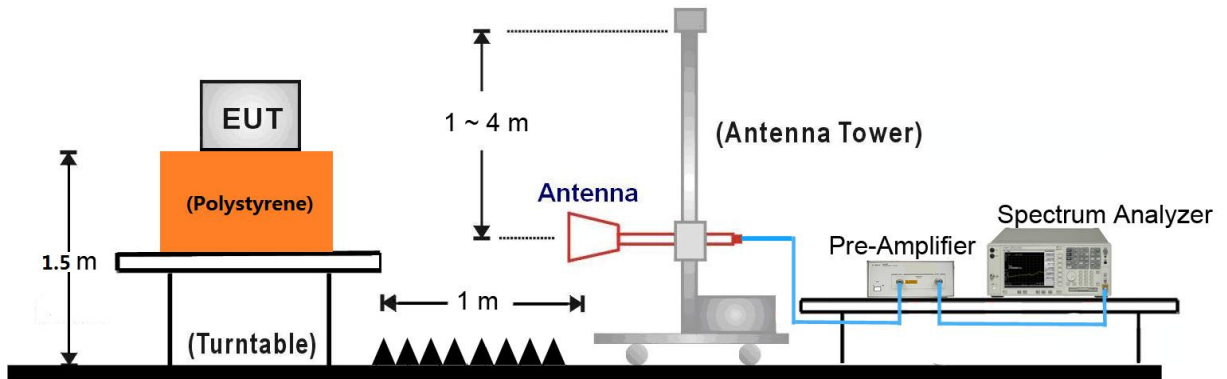

7.6.5. Test Result

Test Mode:	BLE	Test Site:	AC1
Test Channel:	00	Test Engineer:	Bruce Wang
Remark:	1. Average measurement was not performed if peak level lower than average limit. 2. Other frequency was 20dB below limit line within 1-18GHz, there is not show in the report.		

Mark	Frequency (MHz)	Reading Level (dBμV)	Factor (dB)	Measure Level (dBμV/m)	Limit (dBμV/m)	Margin (dB)	Detector	Polarization
	4808.0	45.0	2.7	47.7	74.0	-26.3	Peak	Horizontal
	5437.0	36.9	3.4	40.3	74.0	-33.7	Peak	Horizontal
*	7205.0	43.6	7.8	51.4	74.0	-22.6	Peak	Horizontal
*	8718.0	36.3	9.0	45.3	74.0	-28.7	Peak	Horizontal
	4799.5	42.5	2.7	45.2	74.0	-28.8	Peak	Vertical
	5394.5	36.2	3.1	39.3	74.0	-34.7	Peak	Vertical
*	7205.0	44.5	7.8	52.3	74.0	-21.7	Peak	Vertical
*	9644.5	35.8	11.0	46.8	74.0	-27.2	Peak	Vertical

Note 1: "*" is not in restricted band, its limit is 20dBc of the fundamental emission level (75.2dBμV/m) or 15.209 which is higher.

Note 2: Measure Level (dBμV/m) = Reading Level (dBμV) + Factor (dB)

Factor (dB) = Cable Loss (dB) + Antenna Factor (dB/m) - Pre_Amplifier Gain (dB)

Test Mode:	BLE	Test Site:	AC1
Test Channel:	19	Test Engineer:	Bruce Wang
Remark:	1. Average measurement was not performed if peak level lower than average limit. 2. Other frequency was 20dB below limit line within 1-18GHz, there is not show in the report.		

Mark	Frequency (MHz)	Reading Level (dBμV)	Factor (dB)	Measure Level (dBμV/m)	Limit (dBμV/m)	Margin (dB)	Detector	Polarization
	4876.0	44.1	2.7	46.8	74.0	-27.2	Peak	Horizontal
	7324.0	45.8	8.0	53.8	74.0	-20.2	Peak	Horizontal
*	8837.0	36.4	9.1	45.5	74.0	-28.5	Peak	Horizontal
*	9916.5	35.2	11.5	46.7	74.0	-27.3	Peak	Horizontal
	4884.5	41.8	2.7	44.5	74.0	-29.5	Peak	Vertical
	7315.5	45.5	8.0	53.5	74.0	-20.5	Peak	Vertical
*	8726.5	36.5	9.0	45.5	74.0	-28.5	Peak	Vertical
*	10044.0	35.9	11.6	47.5	74.0	-26.5	Peak	Vertical

Note 1: "*" is not in restricted band, its limit is 20dBc of the fundamental emission level (75.5dBμV/m) or 15.209 which is higher.

Note 2: Measure Level (dBμV/m) = Reading Level (dBμV) + Factor (dB)

Factor (dB) = Cable Loss (dB) + Antenna Factor (dB/m) - Pre_Amplifier Gain (dB)

Test Mode:	BLE	Test Site:	AC1
Test Channel:	39	Test Engineer:	Bruce Wang
Remark:	1. Average measurement was not performed if peak level lower than average limit. 2. Other frequency was 20dB below limit line within 1-18GHz, there is not show in the report.		

Mark	Frequency (MHz)	Reading Level (dBμV)	Factor (dB)	Measure Level (dBμV/m)	Limit (dBμV/m)	Margin (dB)	Detector	Polarization
	4961.0	43.3	2.9	46.2	74.0	-27.8	Peak	Horizontal
	7440.4	46.8	8.0	54.8	74.0	-19.2	Peak	Horizontal
	7440.4	25.4	8.0	33.4	54.0	-20.6	Average	Horizontal
*	8684.0	36.8	9.0	45.8	74.0	-28.2	Peak	Horizontal
*	9899.5	35.1	11.6	46.7	74.0	-27.3	Peak	Horizontal
	4961.0	41.9	2.9	44.8	74.0	-29.2	Peak	Vertical
	7443.0	45.6	8.0	53.6	74.0	-20.4	Peak	Vertical
*	8743.5	36.4	9.0	45.4	74.0	-28.6	Peak	Vertical
*	10052.5	35.7	11.5	47.2	74.0	-26.8	Peak	Vertical

Note 1: "*" is not in restricted band, its limit is 20dBc of the fundamental emission level (74.9dBμV/m) or 15.209 which is higher.

Note 2: Measure Level (dBμV/m) = Reading Level (dBμV) + Factor (dB)

Factor (dB) = Cable Loss (dB) + Antenna Factor (dB/m) - Pre_Amplifier Gain (dB)

The worst case of Radiated Emission below 1GHz:

Site: AC1	Time: 2016/09/19 - 21:27
Limit: FCC_Part15.209_RE(3m)	Engineer: Bruce Wang
Probe: VULB9168_20-2000MHz	Polarity: Horizontal
EUT: STEADICAM eVo	Power: By Battery
Worse Case Mode: Transmit by BLE at channel 2402MHz	

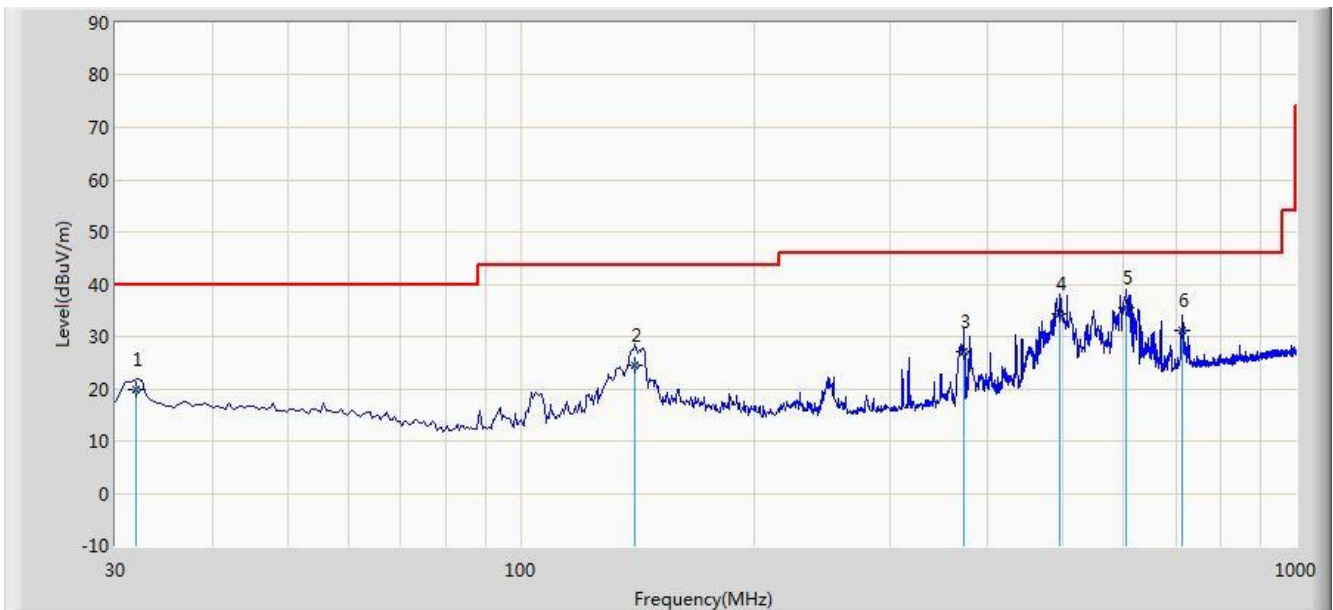

No	Flag	Mark	Frequency (MHz)	Measure Level (dBuV/m)	Reading Level (dBuV)	Over Limit (dB)	Limit (dBuV/m)	Factor (dB)	Type
1			31.940	19.892	6.202	-20.108	40.000	13.690	QP
2			140.580	24.554	10.021	-18.946	43.500	14.533	QP
3			372.895	27.181	11.225	-18.819	46.000	15.956	QP
4			495.540	34.296	15.885	-11.704	46.000	18.410	QP
5		*	604.240	35.572	14.998	-10.428	46.000	20.574	QP
6			713.358	31.126	8.932	-14.874	46.000	22.194	QP

Note: Measure Level (dBuV/m) = Reading Level (dBuV) + Factor (dB)

Factor (dB) = Cable Loss (dB) + Antenna Factor (dB/m)

Site: AC1	Time: 2016/09/19 - 21:30
Limit: FCC_Part15.209_RE(3m)	Engineer: Bruce Wang
Probe: VULB9168_20-2000MHz	Polarity: Vertical
EUT: STEADICAM eVo	Power: By Battery
Worse Case Mode: Transmit by BLE at channel 2402MHz	

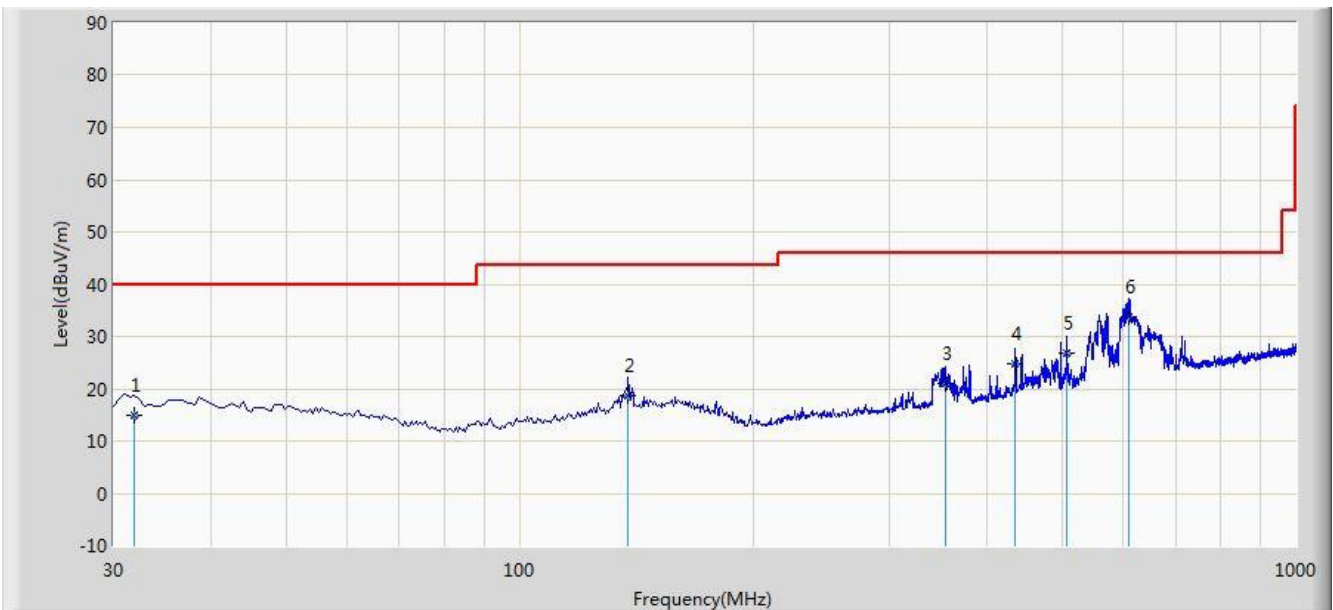

No	Flag	Mark	Frequency (MHz)	Measure Level (dBuV/m)	Reading Level (dBuV)	Over Limit (dB)	Limit (dBuV/m)	Factor (dB)	Type
1			31.940	14.944	1.254	-25.056	40.000	13.690	QP
2			138.155	18.628	4.285	-24.872	43.500	14.343	QP
3			353.495	21.081	5.552	-24.919	46.000	15.529	QP
4			435.460	24.798	7.343	-21.202	46.000	17.455	QP
5			507.240	26.855	8.221	-19.145	46.000	18.634	QP
6		*	610.060	33.906	13.214	-12.094	46.000	20.692	QP

Note: Measure Level (dB μ V/m) = Reading Level (dB μ V) + Factor (dB)

Factor (dB) = Cable Loss (dB) + Antenna Factor (dB/m)

Site: AC1	Time: 2016/09/19 - 21:54
Limit: FCC_Part15.209_RE(3m)	Engineer: Bruce Wang
Probe: FMZB1519_0.009-30MHz	Polarity: Face On
EUT: STEADICAM eVo	Power: By Battery
Note: There is the ambient noise within frequency range 9kHz~30MHz.	

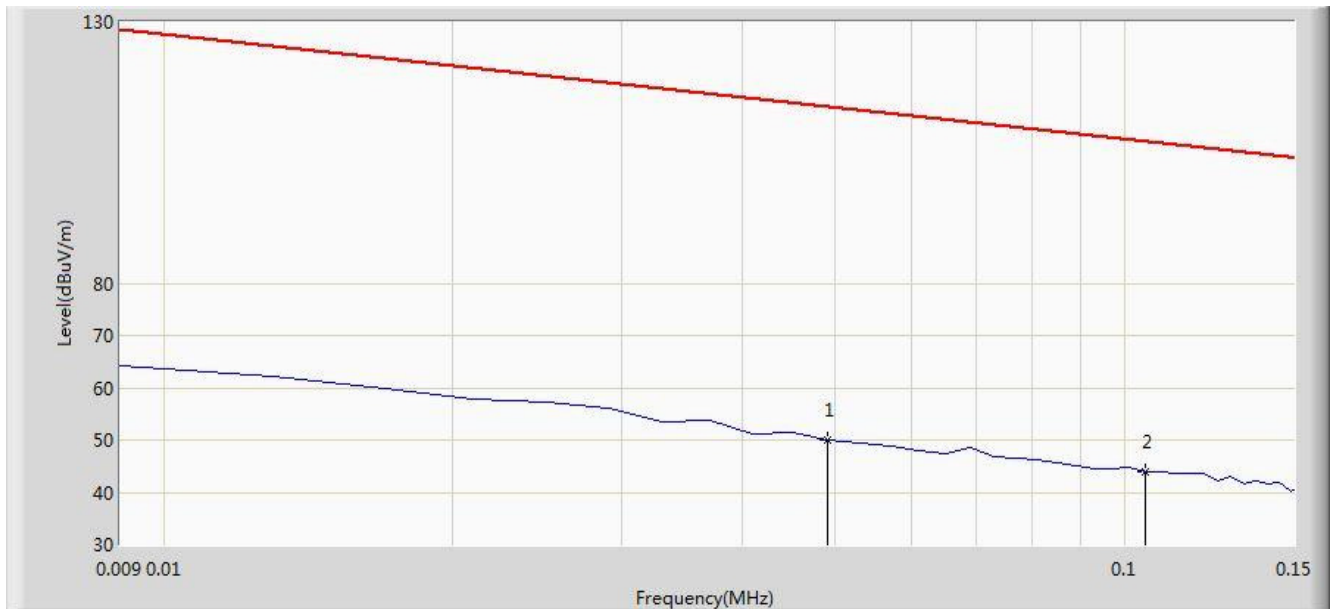

No	Flag	Mark	Frequency (MHz)	Measure Level (dBuV/m)	Reading Level (dBuV)	Over Limit (dB)	Limit (dBuV/m)	Factor (dB)	Type
1			0.049	50.112	29.552	-63.688	113.800	20.560	AV
2		*	0.105	44.043	23.845	-63.137	107.180	20.198	QP

Note: Measure Level (dB μ V/m) = Reading Level (dB μ V) + Factor (dB)

Factor (dB) = Cable Loss (dB) + Antenna Factor (dB/m)

Site: AC1	Time: 2016/09/19 - 22:05
Limit: FCC_Part15.209_RE(3m)	Engineer: Bruce Wang
Probe: FMZB1519_0.009-30MHz	Polarity: Face On
EUT: STEADICAM eVo	Power: By Battery
Note: There is the ambient noise within frequency range 9kHz~30MHz.	

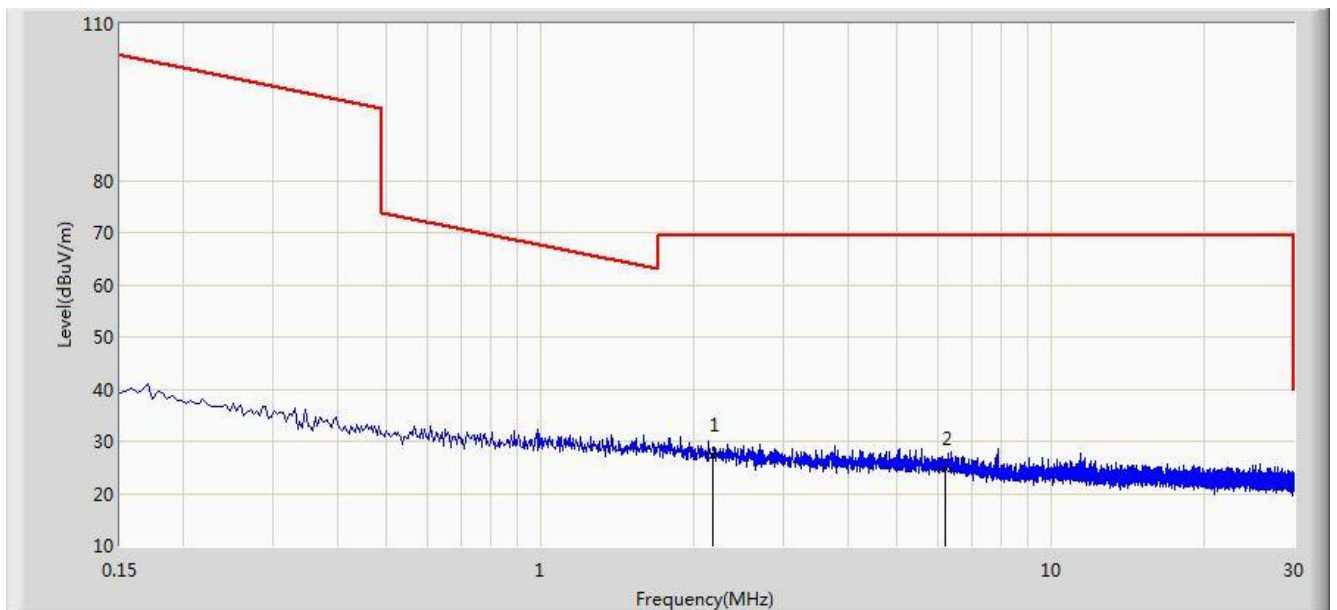

No	Flag	Mark	Frequency (MHz)	Measure Level (dBuV/m)	Reading Level (dBuV)	Over Limit (dB)	Limit (dBuV/m)	Factor (dB)	Type
1		*	2.175	27.371	6.960	-42.129	69.500	20.412	QP
2			6.216	24.786	4.701	-44.714	69.500	20.085	QP

Note: Measure Level (dB μ V/m) = Reading Level (dB μ V) + Factor (dB)

Factor (dB) = Cable Loss (dB) + Antenna Factor (dB/m)

Site: AC1	Time: 2016/09/19 - 22:45
Limit: FCC_Part15.209_RE(1m)	Engineer: Bruce Wang
Probe: BBHA9170_18-40GHz	Polarity: Horizontal
EUT: STEADICAM eVo	Power: By Battery
Note: There is the ambient noise within frequency range 18GHz~25GHz.	

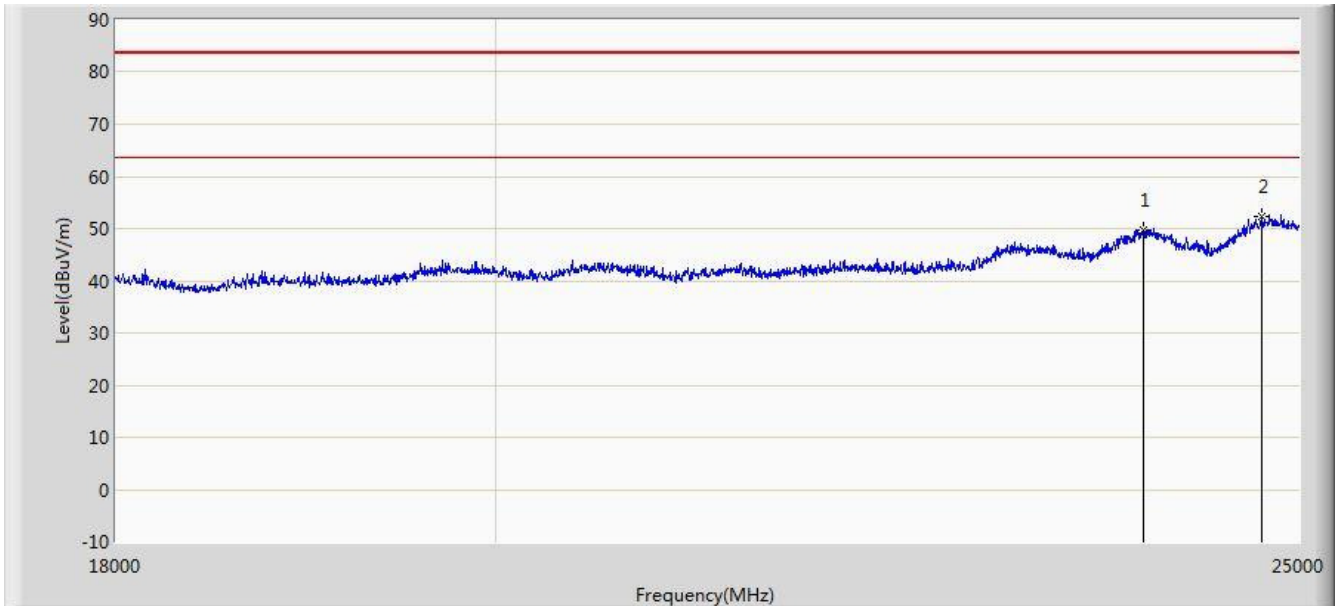

No	Flag	Mark	Frequency (MHz)	Measure Level (dBuV/m)	Reading Level (dBuV)	Over Limit (dB)	Limit (dBuV/m)	Factor (dB)	Type
1			23943.000	49.776	35.866	-33.724	83.500	13.910	PK
2		*	24741.000	52.375	37.681	-31.125	83.500	14.694	PK

Note: Measure Level (dB μ V/m) = Reading Level (dB μ V) + Factor (dB)

Factor (dB) = Cable Loss (dB) + Antenna Factor (dB/m) - Pre_Amplifier Gain (dB)

Site: AC1	Time: 2016/09/19 - 22:55
Limit: FCC_Part15.209_RE(1m)	Engineer: Bruce Wang
Probe: BBHA9170_18-40GHz	Polarity: Vertical
EUT: STEADICAM eVo	Power: By Battery
Note: There is the ambient noise within frequency range 18GHz~25GHz.	

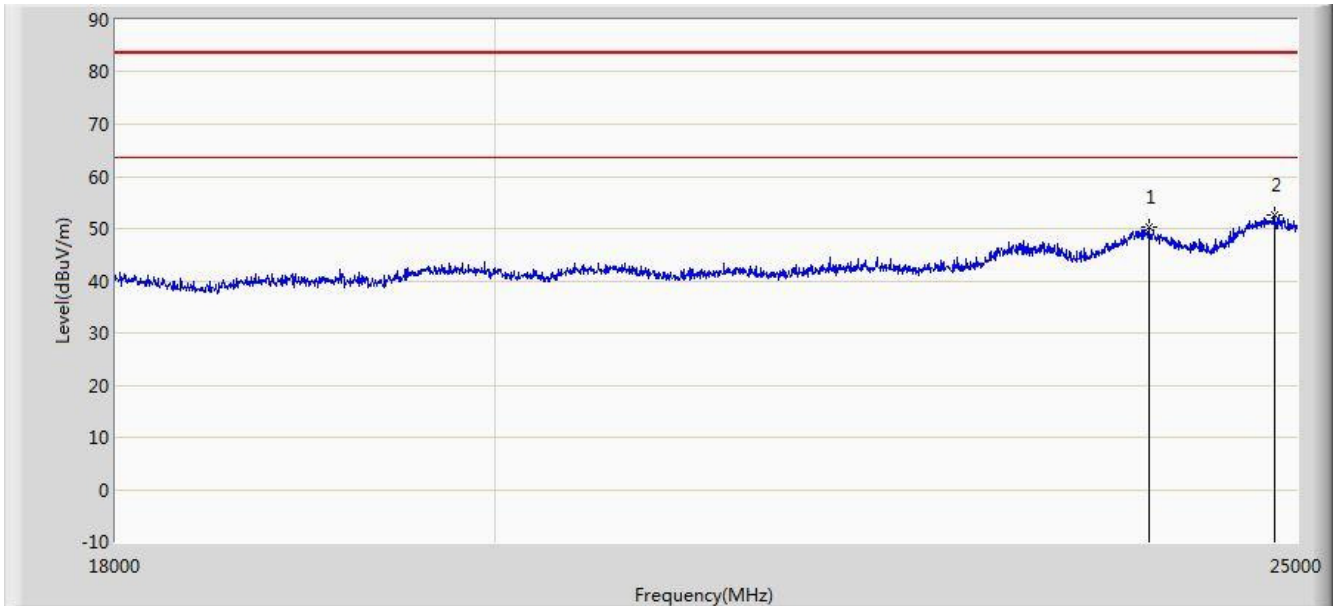

No	Flag	Mark	Frequency (MHz)	Measure Level (dBuV/m)	Reading Level (dBuV)	Over Limit (dB)	Limit (dBuV/m)	Factor (dB)	Type
1			23999.000	50.379	36.435	-33.121	83.500	13.944	PK
2		*	24846.000	52.503	37.735	-30.997	83.500	14.768	PK

Note: Measure Level (dB μ V/m) = Reading Level (dB μ V) + Factor (dB)

Factor (dB) = Cable Loss (dB) + Antenna Factor (dB/m) - Pre_Amplifier Gain (dB)

7.7. Radiated Restricted Band Edge Measurement

7.7.1. Test Result

Site: AC1	Time: 2016/08/24 - 11:41
Limit: FCC_Part15.209_RE(3m)	Engineer: Bruce Wang
Probe: BBHA9120D_1-18GHz	Polarity: Horizontal
EUT: STEADICAM eVo	Power: By Battery
Test Mode: Transmit by BLE at Channel 2402MHz	

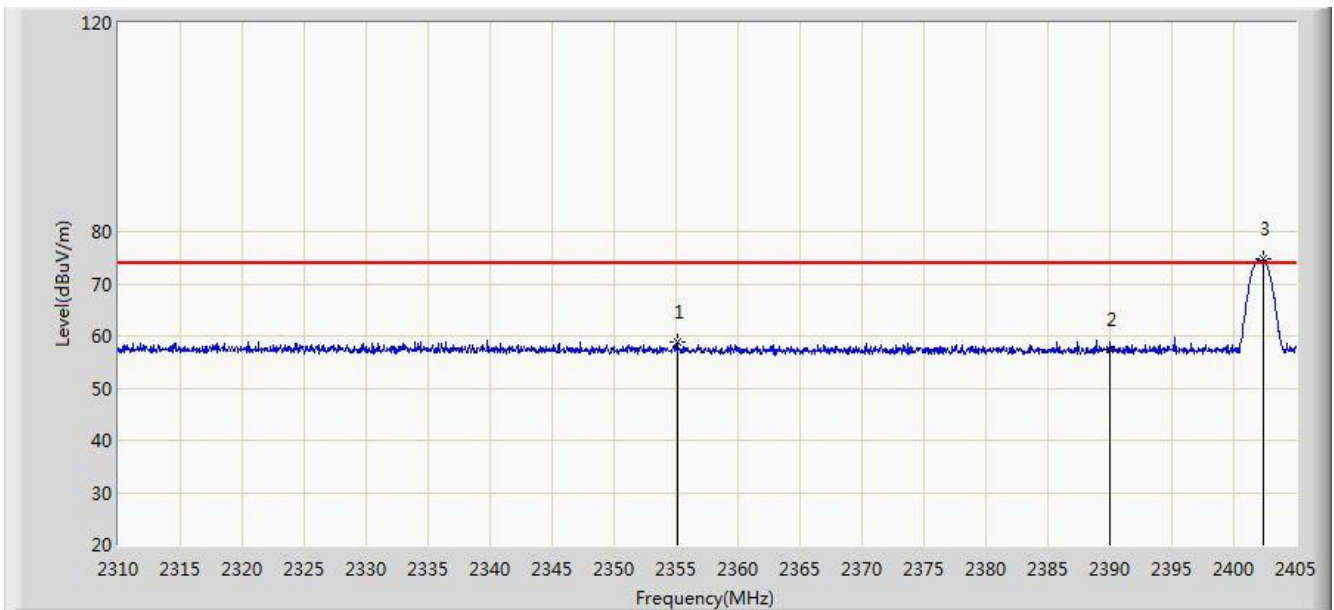

No	Flag	Mark	Frequency (MHz)	Measure Level (dBuV/m)	Reading Level (dBuV)	Over Limit (dB)	Limit (dBuV/m)	Factor (dB)	Type
1			2355.077	58.898	27.625	-15.102	74.000	31.274	PK
2			2390.000	57.460	26.257	-16.540	74.000	31.203	PK
3		*	2402.387	74.652	43.468	N/A	N/A	31.184	PK

Note: Measure Level (dB μ V/m) = Reading Level (dB μ V) + Factor (dB)

Factor (dB) = Cable Loss (dB) + Antenna Factor (dB/m)

Site: AC1	Time: 2016/08/24 - 11:46
Limit: FCC_Part15.209_RE(3m)	Engineer: Bruce Wang
Probe: BBHA9120D_1-18GHz	Polarity: Horizontal
EUT: STEADICAM eVo	Power: By Battery
Test Mode: Transmit by BLE at Channel 2402MHz	

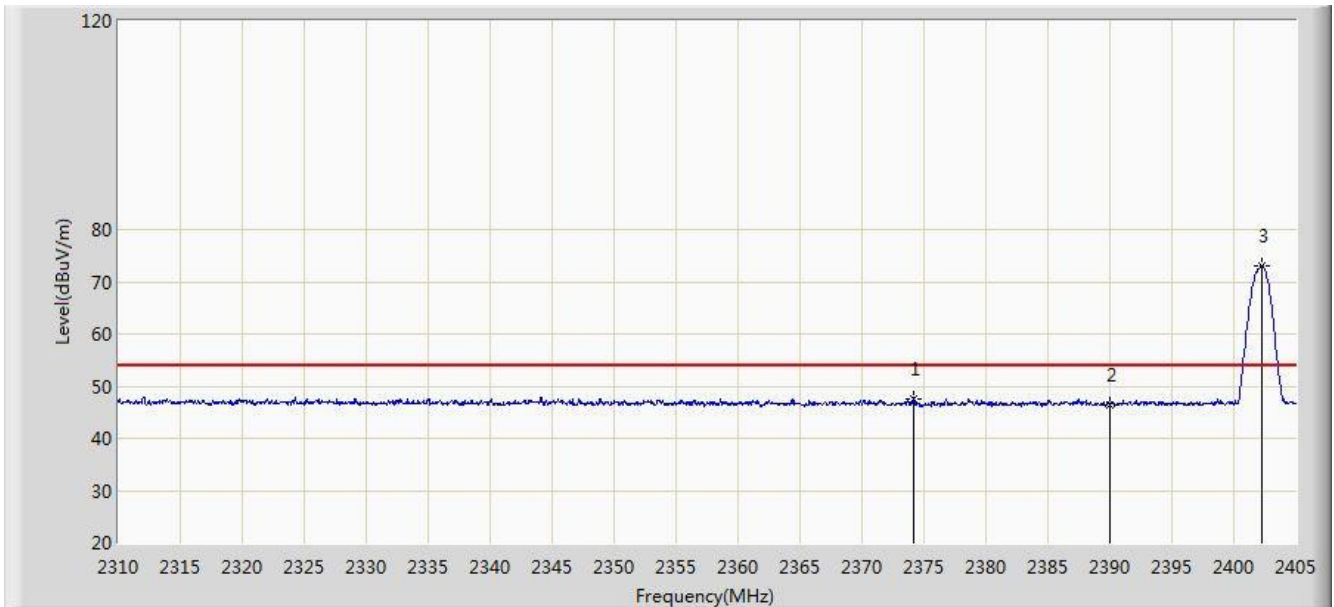

No	Flag	Mark	Frequency (MHz)	Measure Level (dBuV/m)	Reading Level (dBuV)	Over Limit (dB)	Limit (dBuV/m)	Factor (dB)	Type
1			2374.125	47.608	16.376	-6.392	54.000	31.232	AV
2			2390.000	46.277	15.074	-7.723	54.000	31.203	AV
3		*	2402.245	73.027	41.843	N/A	N/A	31.184	AV

Note: Measure Level (dB μ V/m) = Reading Level (dB μ V) + Factor (dB)

Factor (dB) = Cable Loss (dB) + Antenna Factor (dB/m)

Site: AC1	Time: 2016/08/24 - 11:48
Limit: FCC_Part15.209_RE(3m)	Engineer: Bruce Wang
Probe: BBHA9120D_1-18GHz	Polarity: Vertical
EUT: STEADICAM eVo	Power: By Battery
Test Mode: Transmit by BLE at Channel 2402MHz	

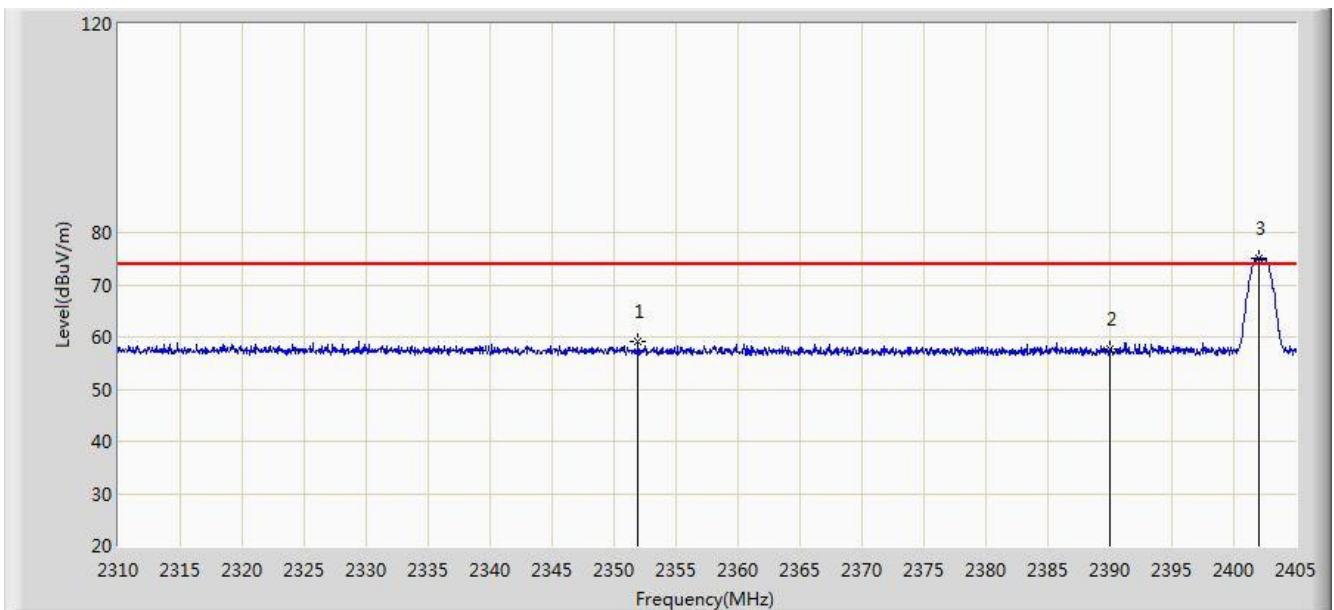

No	Flag	Mark	Frequency (MHz)	Measure Level (dBuV/m)	Reading Level (dBuV)	Over Limit (dB)	Limit (dBuV/m)	Factor (dB)	Type
1			2351.942	59.273	27.988	-14.727	74.000	31.285	PK
2			2390.000	57.548	26.345	-16.452	74.000	31.203	PK
3		*	2402.008	75.217	44.033	N/A	N/A	31.184	PK

Note: Measure Level (dB μ V/m) = Reading Level (dB μ V) + Factor (dB)

Factor (dB) = Cable Loss (dB) + Antenna Factor (dB/m)

Site: AC1	Time: 2016/08/24 - 11:51
Limit: FCC_Part15.209_RE(3m)	Engineer: Bruce Wang
Probe: BBHA9120D_1-18GHz	Polarity: Vertical
EUT: STEADICAM eVo	Power: By Battery
Test Mode: Transmit by BLE at Channel 2402MHz	

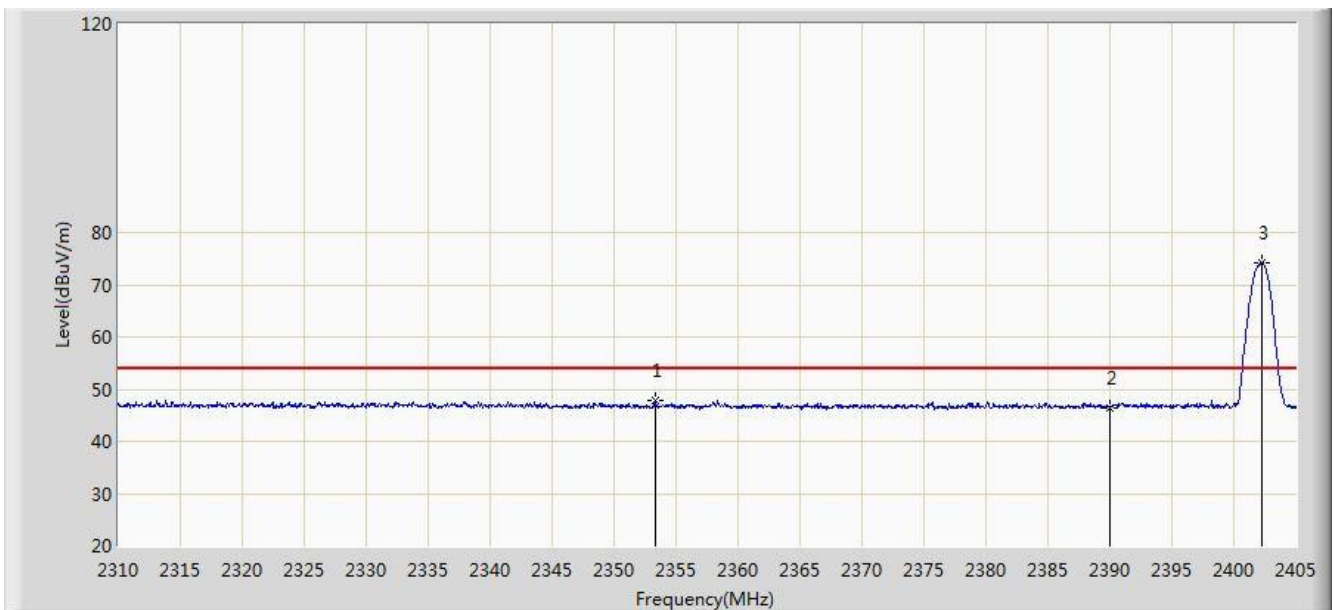

No	Flag	Mark	Frequency (MHz)	Measure Level (dBuV/m)	Reading Level (dBuV)	Over Limit (dB)	Limit (dBuV/m)	Factor (dB)	Type
1			2353.320	47.887	16.607	-6.113	54.000	31.280	AV
2			2390.000	46.484	15.281	-7.516	54.000	31.203	AV
3		*	2402.292	74.108	42.924	N/A	N/A	31.184	AV

Note: Measure Level (dB μ V/m) = Reading Level (dB μ V) + Factor (dB)

Factor (dB) = Cable Loss (dB) + Antenna Factor (dB/m)

Site: AC1	Time: 2016/08/24 - 11:55
Limit: FCC_Part15.209_RE(3m)	Engineer: Bruce Wang
Probe: BBHA9120D_1-18GHz	Polarity: Horizontal
EUT: STEADICAM eVo	Power: By Battery
Test Mode: Transmit by BLE at Channel 2480MHz	

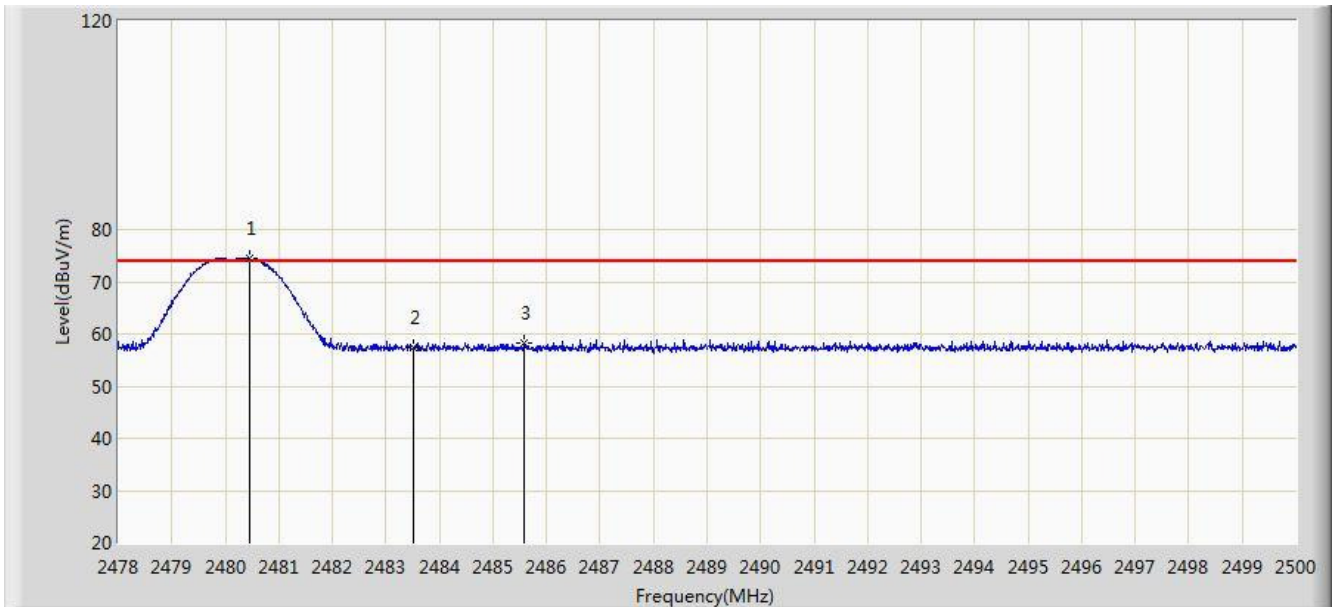

No	Flag	Mark	Frequency (MHz)	Measure Level (dBuV/m)	Reading Level (dBuV)	Over Limit (dB)	Limit (dBuV/m)	Factor (dB)	Type
1		*	2480.453	74.506	43.321	N/A	N/A	31.185	PK
2			2483.500	57.474	26.281	-16.526	74.000	31.194	PK
3			2485.568	58.384	27.185	-15.616	74.000	31.198	PK

Note: Measure Level (dB μ V/m) = Reading Level (dB μ V) + Factor (dB)

Factor (dB) = Cable Loss (dB) + Antenna Factor (dB/m)

Site: AC1	Time: 2016/08/24 - 11:59
Limit: FCC_Part15.209_RE(3m)	Engineer: Bruce Wang
Probe: BBHA9120D_1-18GHz	Polarity: Horizontal
EUT: STEADICAM eVo	Power: By Battery
Test Mode: Transmit by BLE at Channel 2480MHz	

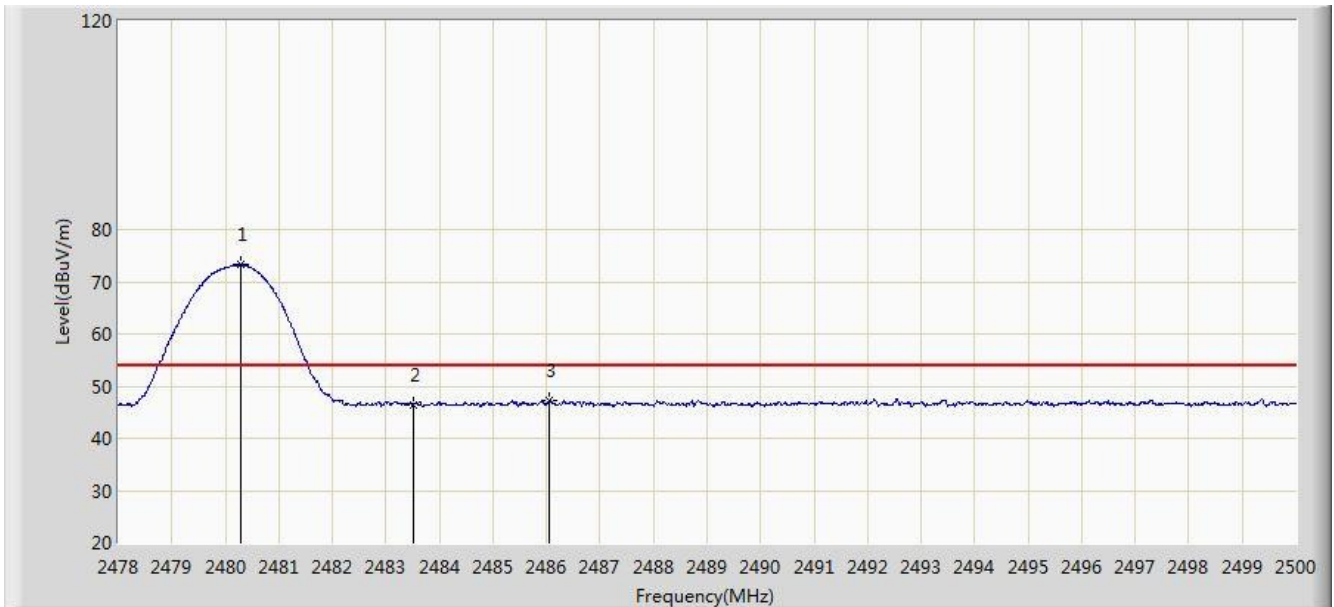

No	Flag	Mark	Frequency (MHz)	Measure Level (dBuV/m)	Reading Level (dBuV)	Over Limit (dB)	Limit (dBuV/m)	Factor (dB)	Type
1		*	2480.288	73.261	42.076	N/A	N/A	31.185	AV
2			2483.500	46.407	15.214	-7.593	54.000	31.194	AV
3			2486.052	47.192	15.992	-6.808	54.000	31.200	AV

Note: Measure Level (dB μ V/m) = Reading Level (dB μ V) + Factor (dB)

Factor (dB) = Cable Loss (dB) + Antenna Factor (dB/m)

Site: AC1	Time: 2016/08/24 - 12:00
Limit: FCC_Part15.209_RE(3m)	Engineer: Bruce Wang
Probe: BBHA9120D_1-18GHz	Polarity: Vertical
EUT: STEADICAM eVo	Power: By Battery
Test Mode: Transmit by BLE at Channel 2480MHz	

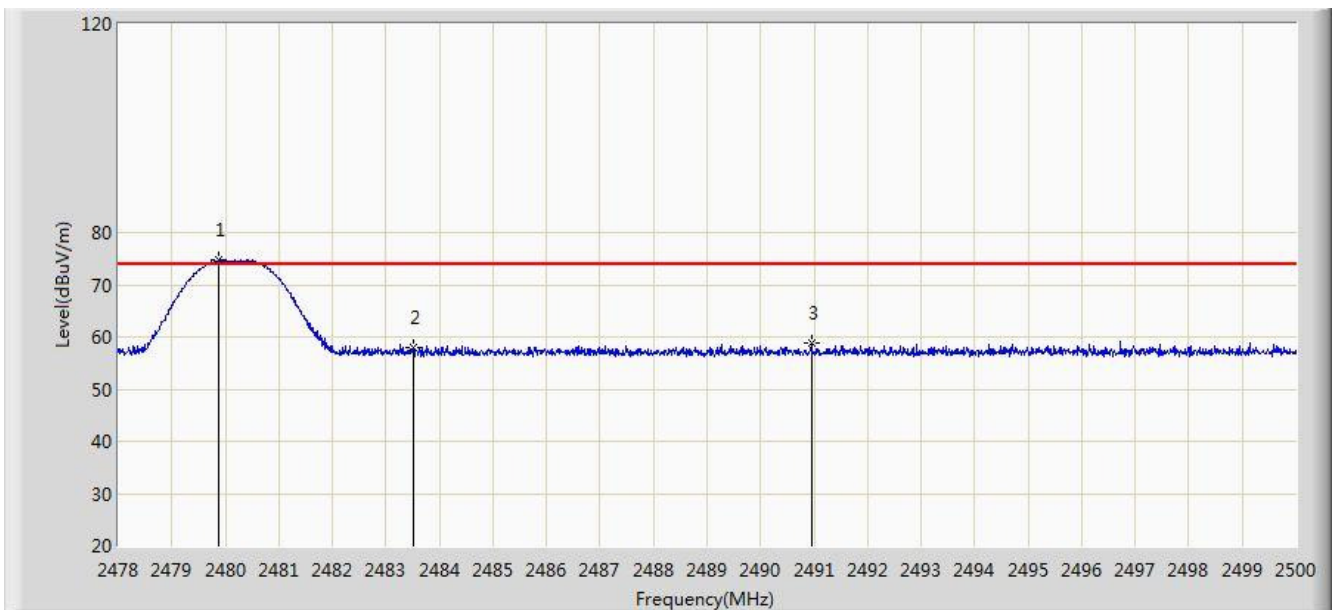

No	Flag	Mark	Frequency (MHz)	Measure Level (dBuV/m)	Reading Level (dBuV)	Over Limit (dB)	Limit (dBuV/m)	Factor (dB)	Type
1		*	2479.870	74.858	43.674	N/A	N/A	31.184	PK
2			2483.500	57.910	26.717	-16.090	74.000	31.194	PK
3			2490.958	58.754	27.541	-15.246	74.000	31.213	PK

Note: Measure Level (dB μ V/m) = Reading Level (dB μ V) + Factor (dB)

Factor (dB) = Cable Loss (dB) + Antenna Factor (dB/m)

Site: AC1	Time: 2016/08/24 - 12:03
Limit: FCC_Part15.209_RE(3m)	Engineer: Bruce Wang
Probe: BBHA9120D_1-18GHz	Polarity: Vertical
EUT: STEADICAM eVo	Power: By Battery
Test Mode: Transmit by BLE at Channel 2480MHz	

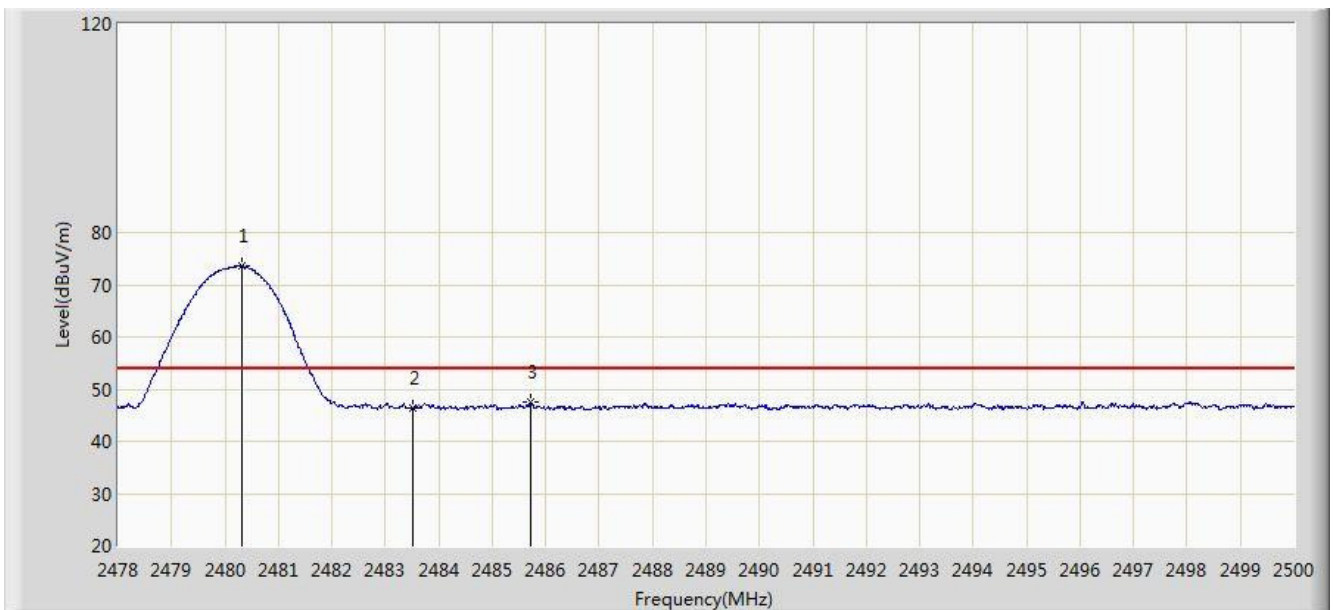

No	Flag	Mark	Frequency (MHz)	Measure Level (dBuV/m)	Reading Level (dBuV)	Over Limit (dB)	Limit (dBuV/m)	Factor (dB)	Type
1		*	2480.310	73.586	42.401	N/A	N/A	31.185	AV
2			2483.500	46.432	15.239	-7.568	54.000	31.194	AV
3			2485.722	47.392	16.193	-6.608	54.000	31.200	AV

Note: Measure Level (dB μ V/m) = Reading Level (dB μ V) + Factor (dB)

Factor (dB) = Cable Loss (dB) + Antenna Factor (dB/m)

7.8. AC Conducted Emissions Measurement

7.8.1. Test Limit

FCC Part 15 Subpart C Paragraph 15.207 Limits		
Frequency (MHz)	QP (dBuV)	AV (dBuV)
0.15 - 0.50	66 - 56	56 - 46
0.50 - 5.0	56	46
5.0 - 30	60	50

Note 1: The lower limit shall apply at the transition frequencies.

Note 2: The limit decreases linearly with the logarithm of the frequency in the range 0.15MHz to 0.5MHz.

7.8.2. Test Setup

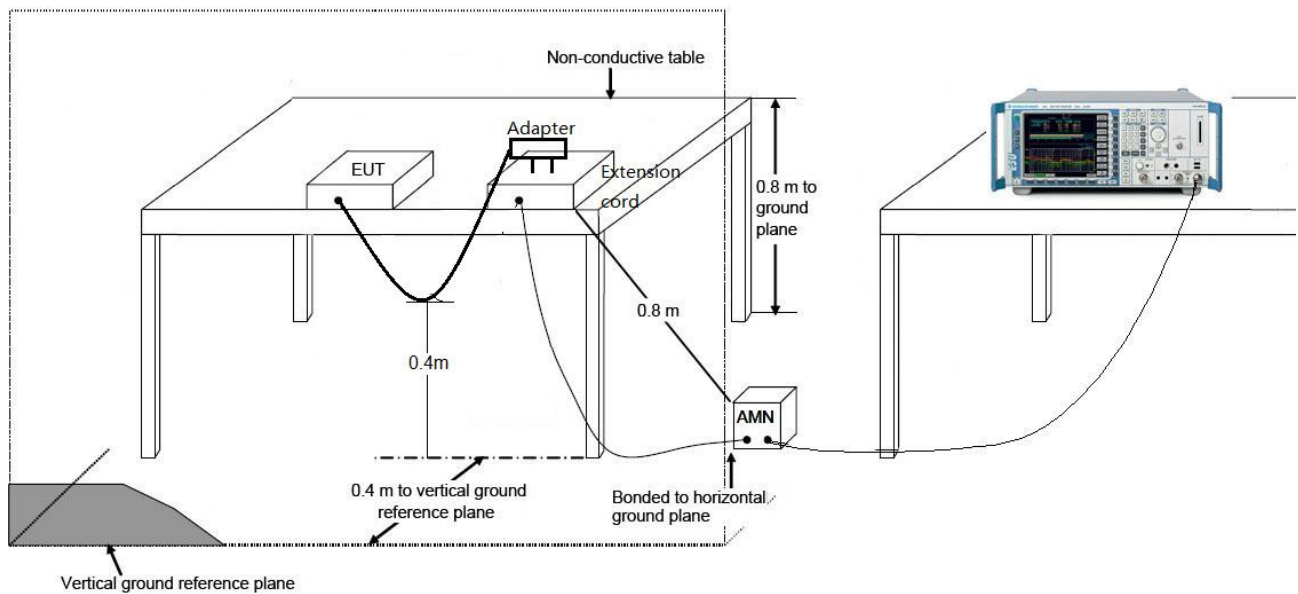

7.8.3. Test Result

The EUT is powered by battery, so this test item is not applicable.

8. CONCLUSION

The data collected relate only the item(s) tested and show that the **STEADICAM eVo** is in compliance with Part 15C of the FCC Rule and RSS-247 Rule.

————— The End —————