

E10T

QUICK START GUIDE V1.0

YUNEEC

Introduction and Overview

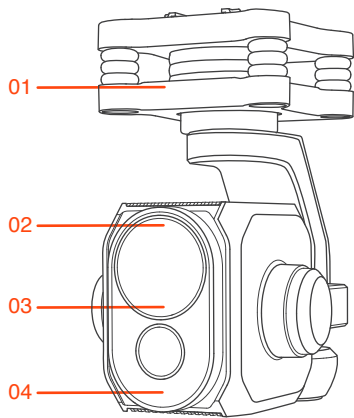

- 01 Damping Plate
- 02 LED Status Indicator
- 03 RGB Camera Lens
- 04 Infrared Camera Lens

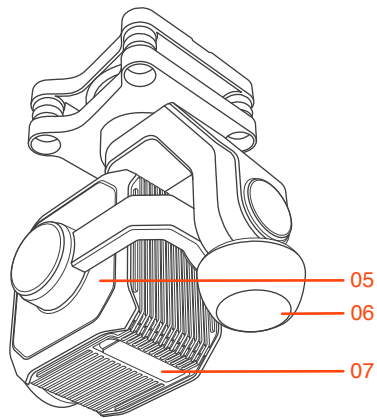

- 05 The Gimbal
- 06 GHzAntenna
- 07 Card Upgrading Port

Specifications

General

Name: E10T
Dimensions: 123*81*140
Weight: 371g

Environmental

Operating Temperature Range: -10°C-40°C

Camera

Infrared Lens :

Thermal Imaging System:
Uncooled Vanadium (VOx) Microbolometer
Sensitivity (NE Δ T) : <50 mK @f/1.0
FPA/Digital Video Display Formats: 320 x 256
Pixel Size: 12 μ m
Spectral Band: 8 - 14 μ m
Exportable Frame Rates: <9Hz (U.S. export restrictions)
Full Frame Rate: 30Hz
Image Formats: JPEG, TIFF
Video Format: MP4
Scene Range (high gain): -25°C to 100°C
Scene Range (low gain): -40°C to 550°C
Point Temperature Measurement: 3*3
NTSC/PAL field switchable: yes
Image Optimization: Support
Digital Image Enhancement: Support
Polarity Control (black hot/White hot) : yes
Color & Monochrome Palettes (LUT): yes
Digital Zoom Range: 1x , 2x , 4x , 8x
Lense: 4.4mm F/1.0 50°FOV 6.5mm F/1.0 34°FOV
9.1mm F/1.0 24°FOV 13.8mm F/1.0 16°FOV

Gimbal

Angular Vibration Range: 0.03°
Mount: Detachable
Controllable Range: Tilt: +15° to -90° Pan: \pm 360°
Mechanical Range: Tilt: +50° to -140° Pan: \pm 360°, Roll: \pm 50°

RGB Lens:

Sensor: CMOS 1/2.8"
Effective Pixels: 2.13MP
Lens: F2.8 equivalent focal length: 23mm
FOV: 90°
Video Resolutions: FHD: 1920x1080 30FPS
Photo Formats: JPEG
Video Formats: MP4
Operation Mode: Capture, Record
Exposure Mode: Program AE Mode, Manual Exposure Mode
Exposure Compensation: \pm 2
Metering Mode: Spot Metering, Center-weighted
Metering, Average Metering
Shutter Speed: 1/30 – 1/8000 s
White Balance: Daylight, Cloudy, Auto, Fluorescent, Incandescent, Sunrise/Sunset
ISO Range: 100-3200
Digital Downlink Distance: 2km

Gimbal Installing

Assembling

Step 1.

Find the arrow printed on the top of the damping plate, which indicates the correct direction for installation.

Step 2.

Slide the E10T in the indicated direction all the way into the mounting slot, until the E10T is secured by the locking clip.

Step 3.

Remove the lens protector.

Step 4.

Insert the Micro SD card.

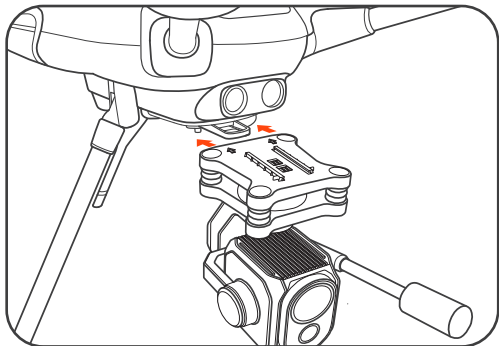

Disassembling

Step 1.

Find the locking clip which is located in front of the mounting slot.

Step 2.

Press and hold the locking clip and push the E10T forward (the direction shown by the arrow).

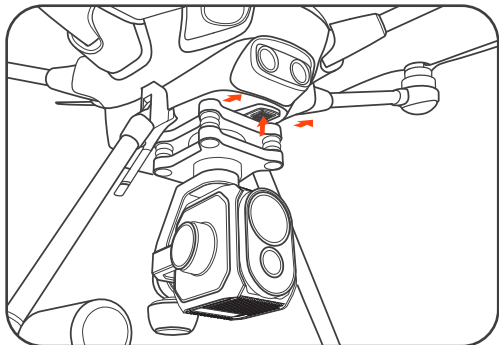

Binding the E10T

Step 1.

Switch on the ST16S and the H520 aircraft.

Step 2.

Tap the [] on the top right corner on the main interface of ST16S.

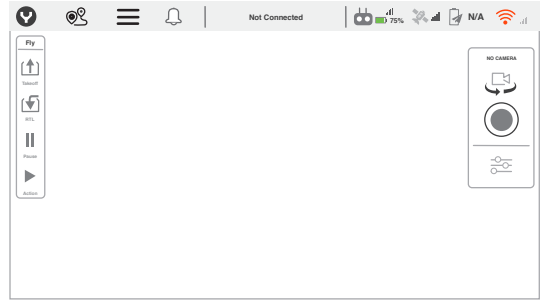

Step 3.

Tap the serial number of the E10T when the following window pops up. (If multiple Yuneec UAS are used, check the ID number on the side of each camera to assure correct camera selection/binding).

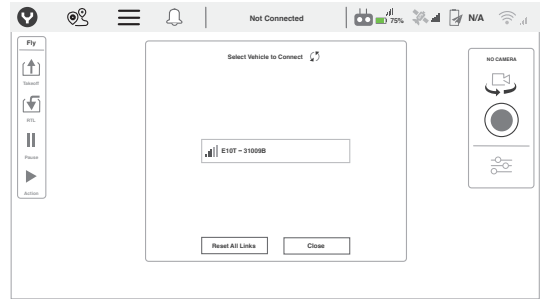

Step 4.

Using the password "1234567890", authorize the camera and tap "OK" to confirm.

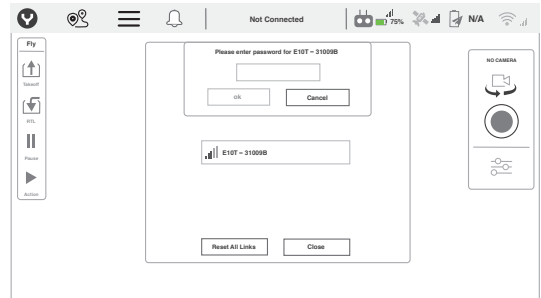

NOTICE

If the connection process is delayed, close the pop up window and then repeat the above steps.

Customer Service

Manufacturer:

Yuneeec International (China) Co., Ltd.

Address: East Zhengwei Road No.388, Jinxi Town, Kunshan City, Jiangsu Province

Distributor:

CN: Youyu (Shanghai) Digital Technology Co., Ltd.

Address: B 15F, 461 HongCao Road, CaoHeJing Software Building XuHui District, Shanghai, China

Tel.: +86 400 8207 506

saleschina@yuneeec.com

HK: Yuneeec HK

Address: 2/F, Man Shung Industrial Building, 7 Lai Yip Street, Kwun Tong, Kowloon, Hong Kong

Tel.: +852 3616 6017

hkcs@yuneeec.com

US: Yuneeec USA Inc

Address: 2275 Sampson Ave, Suite 200 Corona, CA 92879, USA

Tel.: +1 844 898 6332

uscs@yuneeecusa.com

EU: Yuneeec Europe GmbH

Address: Nikolaus-Otto-Strasse 4, 24568 Kaltenkirchen, Germany

Tel.: +49 4191 932620

eucs@yuneeec.com

UK: YUNEEC UK

Address: 181 Victoria Road, Barnet, Hertfordshire EN4 9PA, UK

Tel.: +44(0) 208 449 4321

info@yuneeec.uk

NOTICE

- 1 Ensure that the firmware of the gimbal has been updated to the latest version.
- 2 For the latest product information, please check our official website: www.yuneec.com

WARNING

- Do not try to repair the E10T gimbal camera.
- Do not expose the lens of E10T gimbal camera to extreme light sources.
- Do not operate the E10T gimbal camera in the rain or in environments with high humidity.
- Do not touch or move the E10T gimbal camera until the initialization process has been completed.

The following special language terms are used throughout the product literature to indicate various levels of potential harm when operating this product:

NOTICE Procedures, which if not properly followed, create a possibility of property damage and/or little to no possibility of injury.

CAUTION Procedures, which if not properly followed, create the probability of property damage and/or a possibility of serious injury.

WARNING Procedures, which if not properly followed, create the probability of property damage, collateral damage and/or serious injury or create a high probability of superficial injury.

WARNING

- Read the entire instruction manual to become familiar with the features of the product before operating.
- Do not use with incompatible components or alter this product in any way outside of the instructions provided by Yuneec.
- Failure to use this product in the intended manner as described in instruction manual can result in damage to the product, property and/or cause serious injury.

Collection and Processing of Data

Yuneec may collect navigation information such as GPS data to help improve our products. We may also collect Depth Map information and Infrared Image information from your drone delivered to our service center for repair and maintenance service or any other service. We may also collect other information such as device information, server log information, etc. We may also collect personal information used in registration if you choose to become a registered user and any other information user provided to Yuneec. We may also collect information which user send to other users, and the recipients and senders of such information.

We reserve the right to disclose your information if required to do so by law or in the good-faith belief that such disclosure is needed to comply with applicable laws, for example in response to a court order, judicial subpoena, warrant or request from government, or otherwise cooperating with government agencies or law enforcement.

We also reserve the right to disclose your information that we believe in good faith is necessary or appropriate to: (i) protect ourselves or others from fraudulent, unlawful, or abusive activities; (ii) take precautions against potential liability; (iii) protect the security of the Yuneec Apps embedded into or downloaded onto your drone or any associated equipment and services; (iv) protect the legal rights of ourselves or any others.

Any information we collected may be disclosed or transferred to an acquirer, successor or assignee as part of any potential merger, acquisition, debt financing or other activities that involves transfer of business assets.

We may make the aggregated non-personal information of the users available to third parties for various purposes, including (i) complying with various report obligations; (ii) marketing efforts; (iii) analyzing product safety; (iv) understanding and analyzing our users' interests, habits, usage pattern for certain functionalities, services, content, etc.

Disclaimer

Yuneec Electric Aviation cannot be held liable for any damage, injury or for use of the product in violation with legal regulations, especially in the following circumstances: Damage and/or injury as well violation of legal regulations resulting from a failure to comply with the operating instructions or the instructions at www.yuneec.com, product information, user manual and other legally binding information.

Damage and/or injury as well violation of legal regulations brought about by the influence of alcohol, drugs, medication or other narcotics which may impact on the concentration of the user.

The same applies to illnesses effecting the concentration of the user (dizziness, tiredness, nausea etc.) or other factors compromising mental and physical capabilities.

Intentionally caused damage, injury or violation of legal regulations.

Any request for compensation caused by an accident resulting from use of the product.

Damage and/or injury as well as violation of legal regulations caused by use of the product in a no-fly zone, e.g. next to an airfield, above a motorway or a natural conservation area.

Malfunction of the product caused by retrofitting or replacement with components which did not come from Yuneec Electric Aviation.

Damage and/or injury caused by the use of replica parts (non-original parts).

Damage and/or injury as well as violation of legal regulations caused by incorrect operation or misjudgement.

Damage and/or injury caused by damaged spare parts or not using original Yuneec Electric Aviation spare parts.

Damage and/or injury as well as violation of legal regulations caused by ignoring the low voltage battery warning.

Damage and/or injury as well as violation of legal regulations caused by operating the model in a magnetic field (e.g. high voltage lines, electricity/ transformer stations, radio towers, mobile phone masts etc.), a strong wireless

signal environment, no-fly zones, poor visibility and in the event of vision impairments or other impacts on the pilot which are left unchecked etc.

Damage and/or injury brought about through a violation of the legal regulations for operating the model, in unsuitable weather conditions, e.g. rain, wind, snow, hail, storms, hurricanes etc.

Damage and/or injury as well as violation of legal regulations caused by force majeure, e.g. collision, fire, explosion, flooding, tsunami, landslide, avalanche, earthquake or other forces of nature.

Damage and/or injury as well as violation of legal regulations caused by the illegal or immoral use of the model, e.g. capturing videos or recording data which infringes upon/harms the privacy of other people.

Damage and/or injury as well as violation of legal regulations caused by incorrect use of the batteries, protection systems, chargers or aircraft.

Consequential damage caused by the incorrect operation of any kind of system components and accessory parts, especially memory cards, whereby image or video material from the camera can become defect.

Any non-compliance with legal obligations, personal injury, material damage and environmental damage caused by use and a failure to comply with the local laws and regulations.

Damage and/or injury as well as violation of legal regulations caused by hazardous use without sufficient practical experience.

Damage and/or injury as well as violation of legal regulations caused by flying in legally defined no-fly zones.

Further losses which do not fall within the scope of use defined by Yuneec Electric Aviation as improper.

This product is designed for both professional use and personal, private use. The national and international laws and regulations in force as the time of taking off must be adhered to.

Regulation Information

FCC Statement

This equipment has been tested and found to comply with the limits for Part 15 of the FCC rules. These limits are designed to provide reasonable protection against harmful interference in a residential installation. This equipment generates, uses and can radiate radio frequency energy and, if not installed and used in accordance with the instructions, may cause harmful interference to radio communications. However, there is no guarantee that interference will not occur in a particular installation. If this equipment does cause harmful interference to radio or television reception, which can be determined by turning the equipment off and on, the user is encouraged to try to correct the interference by one or more of the following measures:

- Reorient or relocate the receiving antenna.
- Increase the separation between the equipment and receiver.
- Connect the equipment to an outlet on a circuit different from that to which the receiver is connected.
- Consult the dealer or an experienced radio/TV technician for help.

This device complies with part 15 of the FCC rules. Operation is subject to the following two conditions:

(1) This device may not cause harmful interference, and (2) this device must accept any interference received, including interference that may cause undesired operation.

RF Exposure Warning

This equipment must be installed and operated in accordance with provided instructions and the antenna(s) used for this transmitter must be installed to provide a separation distance of at least 20 cm from all persons and must not be co-located or operating in conjunction with any other antenna or transmitter. End-users and installers must be provided with antenna installation instructions and transmitter operating conditions for satisfying RF exposure compliance.

IC Radiation Exposure Statement for Canada

This device complies with Industry Canada licence-exempt RSS standard(s). Operation is subject to the following two conditions: (1) this device may not cause interference, and (2) this device must accept any interference, including interference that may cause undesired operation of the device. Le présent appareil est conforme aux CNR d'Industrie Canada applicables aux appareils radio exempts de licence. L'exploitation est autorisée aux deux conditions suivantes : (1) l'appareil ne doit pas produire de brouillage, et (2) l'utilisateur de l'appareil doit accepter tout brouillage radioélectrique subi, même si le brouillage est susceptible d'en compromettre le fonctionnement.

This equipment complies with IC RSS-102 radiation exposure limit set forth for an uncontrolled environment. Cet équipement respecte les limites d'exposition aux rayonnements IC définies pour un environnement non contrôlé

NCC Warning Statement

Article 12

Without permission, any company, firm or user shall not alter the frequency, increase the power, or change the characteristics and functions of the original design of the certified lower power frequency electric machinery.

Article 14

The application of low power frequency electric machineries shall not affect the navigation safety nor interfere a legal communication, if an interference is found, the service will be suspended until improvement is made and the interference no longer exists.

CE Warning Statement

This device meets the EU requirements on the limitation of the general public to electromagnetic fields by way of health protection.

EU Operation Frequency (The Maximum Transmitted Power)

5G Wifi: 5560-5580MHz (27dBm), 5680-5700MHz (27dBm)

EU Compliance Statement

Hereby, Yuneec International (China) Co., Ltd. declares that this device is in compliance with the essential requirements and other relevant provisions of the RED Directive 2014/53/EU. The full text of the EU Declaration of Conformity is available at the following internet address: <http://yuneec.de-downloads>.

Please visit the address above and enter into corresponding product page.