



TEST REPORT

Report Reference No...... : **TRE1405002701** R/C.....: 64789

FCC ID..... : **2ACRAHX-DU8602T**

Applicant's name..... : **HARXON CORPORATION**

Address..... : 6/F, Block B, D3 Building, TCL International E City, No. 1001
 Zhongshanyuan Road, Nanshan District, Shenzhen, 518055, PRC

Manufacturer..... : **HARXON CORPORATION**

Address..... : 6/F, Block B, D3 Building, TCL International E City, No. 1001
 Zhongshanyuan Road, Nanshan District, Shenzhen, 518055, PRC

Test item description : **WIRELESS DATA TRANSCEIVER**

Trade Mark : Harxon

Model/Type reference..... : HX-DU8602T

List Model : HX-DU8602D.
 HX-DU86XXT series: From HX-DU8680T to HX-DU8698T.
 HX-DU86XXD series: From HX-DU8680D to HX-DU8698D

Standard : **FCC Part 90/FCC Part 2/ FCC Part 15B**

Date of receipt of test sample..... : Apr 21, 2014

Date of testing..... : Apr 21, 2014- Jun 24, 2014

Date of issue..... : Jun 24, 2014

Result..... : **PASS**

Compiled by
 (position+printed name+signature)..: File administrators Vivi Zhou

Supervised by
 (position+printed name+signature)..: Project Engineer Eric Wang

Approved by
 (position+printed name+signature)..: RF Manager Hans Hu

Vivi Zhou

Eric Wang

Hans Hu

Testing Laboratory Name : **Shenzhen Huatongwei International Inspection Co., Ltd**

Address..... : Keji Nan No.12 Road, Hi-tech Park, Shenzhen, China

Shenzhen Huatongwei International Inspection Co., Ltd. All rights reserved.

This publication may be reproduced in whole or in part for non-commercial purposes as long as the Shenzhen Huatongwei International Inspection Co., Ltd is acknowledged as copyright owner and source of the material. Shenzhen Huatongwei International Inspection Co., Ltd takes no responsibility for and will not assume liability for damages resulting from the reader's interpretation of the reproduced material due to its placement and context.

Contents

1.	<u>TEST STANDARDS AND TEST DESCRIPTION</u>	3
1.1.	Test Standards	3
1.2.	Test Description	3
2.	<u>SUMMARY</u>	4
2.1.	Client Information	4
2.2.	Product Description	4
2.3.	EUT operation mode	5
2.4.	EUT configuration	5
2.5.	Modifications	5
3.	<u>TEST ENVIRONMENT</u>	6
3.1.	Address of the test laboratory	6
3.2.	Test Facility	6
3.3.	Environmental conditions	7
3.4.	Statement of the measurement uncertainty	7
3.5.	Equipments Used during the Test	8
4.	<u>TEST CONDITIONS AND RESULTS</u>	10
4.1.	Conducted Emissions Test	10
4.2.	Maximum Transmitter Power	13
4.3.	Occupied Bandwidth and Emission Mask Test	18
4.4.	Frequency Stability Test	28
4.5.	Transmitter Frequency Behavior	31
4.6.	Spurious Emssion on Antenna Port	33
4.7.	Transmitter Radiated Spurious Emssion	41
4.8.	Modulation Charcateristics	45
4.9.	Receiver Radiated Spurious Emssion	46
4.10.	Receiver Conducted Spurious Emssion	48

1. Test standards and Test description

1.1. Test Standards

The tests were performed according to following standards:

[FCC Rules Part 90 : 10-01-2013](#): PRIVATE LAND MOBILE RADIO SERVICES.

[TIA/EIA 603 D: June 2010](#): Land Mobile FM or PM Communications Equipment Measurement and Performance Standards.

[47 CFR FCC Part 15 Subpart B: 10-01-2013](#) - Unintentional Radiators

[FCC Part 2: 10-01-2013](#): FREQUENCY ALLOCATIONS AND RADIO TREATY MATTERS; GENERAL RULES AND REGULATIONS

1.2. Test Description

Test Item	Test specification clause	Result
Conducted Emission	FCC Part 15.107	Pass
Maximum Transmitter Power	FCC Part 90.205	Pass
Modulation Characteristic	FCC Part 90.207	N.A
Occupied Bandwidth	FCC Part 90.209	Pass
Emission Mask	FCC Part 90.210	Pass
Frequency Stability	FCC Part 90.213	Pass
Transmitter Frequency Behavior	FCC Part 90.214	Pass
Transmitter Radiated Spurious Emission	FCC Part 90.210	Pass
Spurious Emission On Antenna Port	FCC Part 90.210	Pass
Receiver Radiated Spurious Emission	FCC Part 15.109	N/A
Receiver Conducted Spurious Emission	FCC Part 15.109	N/A

2. Summary

2.1. Client Information

Applicant:	HARXON CORPORATION
Address:	6/F, Block B, D3 Building, TCL International E City, No. 1001 Zhongshanyuan Road, Nanshan District, Shenzhen, 518055, PRC
Manufacturer:	HARXON CORPORATION
Address:	6/F, Block B, D3 Building, TCL International E City, No. 1001 Zhongshanyuan Road, Nanshan District, Shenzhen, 518055, PRC

2.2. Product Description

Name of EUT	WIRELESS DATA TRANSCEIVER
Model Number	HX-DU8602T
Listed Model(s)	HX-DU8602D HX-DU86XXT series: From HX-DU8680T to HX-DU8698T HX-DU86XXD series: From HX-DU8680D to HX-DU8698D
Rated Output Power	High:35 Watts(45.44 dBm) / Low 5Watts(36.99 dBm)
Modulation Type	4FSK&GMSK
Emission Designator	7K60FXD
Channel Separation	12.5KHz
Antenna Type	External
Frequency Range	From 410 MHz to 470 MHz
Power Supply	DC 12.0V

2.3. EUT operation mode

The EUT has been tested under typical operating condition and The Transmitter was operated in the normal operating mode. The TX frequency was fixed which was for the purpose of the measurements.

EUT operation mode no.	Description of operation mode	Additional information
Op 1	4FSK+BW12.5KHz+TX	The equipment is set with 4FSK modulation and 12.5KHz bandwidth at maximum rated power for TX Mode,powered by DC 12.0V
Op2	4FSK+BW12.5KHz+TX	The equipment is set with 4FSK modulation and 12.5KHz bandwidth at minimum rated power for TX Mode,powered by DC 12.0V
Op 3	GMSK+BW12.5KHz+TX	The equipment is set with GMSK modulation and 12.5KHz bandwidth at maximum rated power for TX Mode,powered by DC 12.0V
Op 4	GMSK+BW12.5KHz+TX	The equipment is set with GMSK modulation and 12.5KHz bandwidth at minimum rated power for TX Mode,powered by DC 312.0V

2.4. EUT configuration

The following peripheral devices and interface cables were connected during the measurement:

- - supplied by the manufacturer
- - supplied by the lab

<input type="radio"/>	Power Cable	Length (m) :	/
		Shield :	/
		Detachable :	/
<input type="radio"/>	Multimeter	Manufacturer :	/
		Model No. :	/

2.5. Modifications

No modifications were implemented to meet testing criteria.

3. Test Environment

3.1. Address of the test laboratory

Test lab: Shenzhen Huatongwei International Inspection Co., Ltd.
Address: Keji Nan No.12 Road, Hi-tech Park, Shenzhen, China
Phone: 86-755-26748019 Fax: 86-755-26748089

3.2. Test Facility

The test facility is recognized, certified, or accredited by the following organizations:

CNAS-Lab Code: L1225

Shenzhen Huatongwei International Inspection Co., Ltd. has been assessed and proved to be in compliance with CNAS-CL01 Accreditation Criteria for Testing and Calibration Laboratories (identical to ISO/IEC 17025: 2005 General Requirements) for the Competence of Testing and Calibration Laboratories, Date of Registration: Mar. 01, 2012. Valid time is until February 28, 2015.

A2LA-Lab Cert. No. 2243.01

Shenzhen Huatongwei International Inspection Co., Ltd. EMC Laboratory has been accredited by A2LA for technical competence in the field of electrical testing, and proved to be in compliance with ISO/IEC 17025: 2005 General Requirements for the Competence of Testing and Calibration Laboratories and any additional program requirements in the identified field of testing. Valid time is until Sept 30, 2015.

FCC-Registration No.: 662850

Shenzhen Huatongwei International Inspection Co., Ltd. EMC Laboratory has been registered and fully described in a report filed with the FCC (Federal Communications Commission). The acceptance letter from the FCC is maintained in our files. Registration 662850, Renewal date Jul. 01, 2012, valid time is until Jun. 01, 2015.

IC-Registration No.: 5377A

The 3m Alternate Test Site of Shenzhen Huatongwei International Inspection Co., Ltd. has been registered by Certification and Engineering Bureau of Industry Canada for the performance of radiated measurements with Registration No. 5377A on Dec. 31, 2013, valid time is until Dec. 31, 2016.

ACA

Shenzhen Huatongwei International Inspection Co., Ltd. EMC Laboratory can also perform testing for the Australian C-Tick mark as a result of our A2LA accreditation.

VCCI

The 3m Semi-anechoic chamber (12.2m×7.95m×6.7m) of Shenzhen Huatongwei International Inspection Co., Ltd. has been registered in accordance with the Regulations for Voluntary Control Measures with Registration No.:R-2484. Date of Registration: Dec. 20, 2012. Valid time is until Dec. 29, 2015.

Radiated disturbance above 1GHz measurement of Shenzhen Huatongwei International Inspection Co., Ltd. has been registered in accordance with the Regulations for Voluntary Control Measures with Registration No.: G-292. Date of Registration: Dec. 24, 2013. Valid time is until Dec. 23, 2016.

Main Ports Conducted Interference Measurement of Shenzhen Huatongwei International Inspection Co., Ltd. has been registered in accordance with the Regulations for Voluntary Control Measures with Registration No.: C-2726. Date of Registration: Dec. 20, 2012. Valid time is until Dec. 19, 2015.

Telecommunication Ports Conducted Interference Measurement of Shenzhen Huatongwei International Inspection Co., Ltd. has been registered in accordance with the Regulations for Voluntary Control Measures with Registration No.: T-1837. Date of Registration: May 07, 2013. Valid time is until May 06, 2016.

DNV

Shenzhen Huatongwei International Inspection Co., Ltd. has been found to comply with the requirements of DNV towards subcontractor of EMC and safety testing services in conjunction with the EMC and Low voltage Directives and in the voluntary field. The acceptance is based on a formal quality Audit and follow-ups according to relevant parts of ISO/IEC Guide 17025 (2005), in accordance with the requirements of the DNV Laboratory Quality Manual towards subcontractors. Valid time is until Aug. 24, 2016.

3.3. Environmental conditions

During the measurement the environmental conditions were within the listed ranges:

Temperature:	15-35 ° C
Humidity:	30-60 %
Atmospheric pressure:	950-1050mbar

3.4. Statement of the measurement uncertainty

The data and results referenced in this document are true and accurate. The reader is cautioned that there may be errors within the calibration limits of the equipment and facilities. The measurement uncertainty was calculated for all measurements listed in this test report acc. to CISPR 16 - 4 „Specification for radio disturbance and immunity measuring apparatus and methods – Part 4: Uncertainty in EMC Measurements“ and is documented in the Shenzhen Huatongwei International Inspection Co., Ltd quality system acc. to DIN EN ISO/IEC 17025. Furthermore, component and process variability of devices similar to that tested may result in additional deviation. The manufacturer has the sole responsibility of continued compliance of the device.

Hereafter the best measurement capability for Shenzhen Huatongwei laboratory is reported:

Test Items	Measurement Uncertainty	Notes
Frequency stability	25 Hz	(1)
Transmitter power conducted	0.57 dB	(1)
Transmitter power Radiated	2.20 dB	(1)
Conducted spurious emission 9KHz-40 GHz	1.60 dB	(1)
Conducted Emission 9KHz-30MHz	3.39 dB	(1)
Radiated Emission 30~1000MHz	4.65 dB	(1)
Radiated Emissio 1~18GHz	5.16 dB	(1)
Radiated Emissio 18-40GHz	5.54 dB	(1)
Occupied Bandwidth	-----	(1)
Emission Mask	-----	(1)
Modulation Characteristic	-----	(1)
Transmitter Frequency Behavior	-----	(1)

(1) This uncertainty represents an expanded uncertainty expressed at approximately the 95% confidence level using a coverage factor of k=1.96.

3.5. Equipments Used during the Test

AC Power Conducted Emission				
Name of Equipment	Manufacturer	Model	Serial Number	Calibration Due
Artificial Mains	Rohde&Schwarz	ESH2-Z5	100028	10/25/2014
EMI Test Receiver	Rohde&Schwarz	ESCS 30	100038	10/25/2014
Pulse Limiter	Rohde&Schwarz	ESHSZ2	100044	10/25/2014
EMI Test Software	Rohde&Schwarz	ES-K1 V1.71	N/A	N/A
RF COMMUNICATION TEST SET	HP	8920A	3813A10206	10/25/2014

DC Power Conducted Emission				
Name of Equipment	Manufacturer	Model	Serial Number	Calibration Due
Artificial Mains	Rohde&Schwarz	ESH2-Z6	100210	10/25/2014
Artificial Mains	Rohde&Schwarz	ESH2-Z6	100211	10/25/2014
EMI Test Receiver	Rohde&Schwarz	ESCS 30	100038	10/25/2014
Pulse Limiter	Rohde&Schwarz	ESHSZ2	100044	10/25/2014
EMI Test Software	Rohde&Schwarz	ES-K1 V1.71	N/A	N/A
RF COMMUNICATION TEST SET	HP	8920A	3813A10206	10/25/2014

Modulation Characteristic				
Name of Equipment	Manufacturer	Model	Serial Number	Calibration Due
RF COMMUNICATION TEST SET	HP	8920A	3813A10206	10/25/2014

Frequency Stability				
Name of Equipment	Manufacturer	Model	Serial Number	Calibration Due
RF COMMUNICATION TEST SET	HP	8920A	3813A10206	10/25/2014
Signal Generator	Rohde&Schwarz	SMT03	100059	10/25/2014
Climate Chamber	ESPEC	EL-10KA	05107008	10/25/2014

Maximum Transmitter Power & Spurious Emission On Antenna Port & Occupied Bandwidth & Emission Mask				
Name of Equipment	Manufacturer	Model	Serial Number	Calibration Due
Receiver	Rohde&Schwarz	ESI 26	100009	10/25/2014
Attenuator	R&S	ESH3-22	100449	10/25/2014
RF COMMUNICATION TEST SET	HP	8920A	3813A10206	10/25/2014
High-Pass Filter	Anritsu	MP526B	6220875256	10/25/2014
High-Pass Filter	Anritsu	MP526D	6220878392	10/25/2014
Spectrum Analyzer	Agilent	E4407B	MY44210775	10/25/2014
Spectrum Analyzer	Rohde&Schwarz	FSP40	1164.4391.40	10/25/2014

Transmitter Radiated Spurious Emission				
Name of Equipment	Manufacturer	Model	Serial Number	Calibration Due
Ultra-Broadband Antenna	Rohde&Schwarz	HL562	100015	10/25/2014
EMI Test Receiver	Rohde&Schwarz	ESI 26	100009	10/25/2014
RF Test Panel	Rohde&Schwarz	TS / RSP	335015/ 0017	N/A
HORN ANTENNA	Rohde&Schwarz	HF906	100039	10/25/2014
Turntable	ETS	2088	2149	N/A
Antenna Mast	ETS	2075	2346	N/A
EMI Test Software	Rohde&Schwarz	ES-K1 V1.71	N/A	N/A
RF COMMUNICATION TEST SET	HP	8920A	3813A10206	10/25/2014
Ultra-Broadband Antenna	ShwarzBeck	VULB9163	538	10/25/2014
Ultra-Broadband Antenna	ShwarzBeck	VULB9163	539	10/25/2014
HORN ANTENNA	ShwarzBeck	9120D	1012	10/25/2014
HORN ANTENNA	ShwarzBeck	9120D	1011	10/25/2014
TURNTABLE	MATURO	TT2.0	----	N/A
ANTENNA MAST	MATURO	TAM-4.0-P	----	N/A

Transient Frequency Behavior				
Name of Equipment	Manufacturer	Model	Serial Number	Calibration Due
Signal Generator	Rohde&Schwarz	SMT03	100059	10/25/2014
Storage Oscilloscope	Tektronix	TDS3054B	B033027	10/25/2014
RF COMMUNICATION TEST SET	HP	8920A	3813A10206	10/25/2014

The calibration interval was one year.

4. TEST CONDITIONS AND RESULTS

4.1. Conducted Emissions Test

TEST APPLICABLE

The EUT was tested according to ANSI C63.4 - 2009. The frequency spectrum from 0.15 MHz to 30 MHz was investigated. The LISN used was 50 ohm / 50 u Henry as specified by section 5.1 of ANSI C63.4 - 2009. Cables and peripherals were moved to find the maximum emission levels for each frequency.

TEST CONFIGURATION

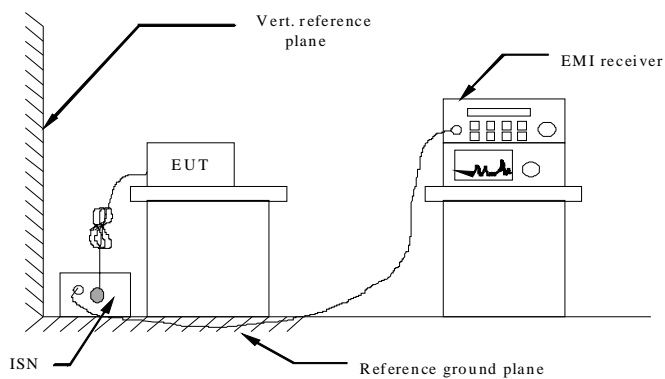

TEST PROCEDURE

- 1 The equipment was set up as per the test configuration to simulate typical actual usage per the user's manual. The EUT is a tabletop system; a wooden table with a height of 0.8 meters is used and is placed on the ground plane as per ANSI C63.4-2009.
- 2 Support equipment, if needed, was placed as per ANSI C63.4-2009. All I/O cables were positioned to simulate typical actual usage as per ANSI C63.4-2009.
- 3 If a EUT received AC120V/60Hz power through a Line Impedance Stabilization Network (LISN) which supplied power source and was grounded to the ground plane.
- 4 If a EUT received DC 13.60V power through a Impedance Stabilization Network (ISN) which supplied power source and was grounded to the ground plane.
- 5 All support equipments received AC power from a second LISN, if any.
- 6 The EUT test program was started. Emissions were measured on each current carrying line of the EUT using a spectrum Analyzer / Receiver connected to the LISN powering the EUT. The LISN has two monitoring points: Line 1 (Hot Side) and Line 2 (Neutral Side). Two scans were taken: one with Line 1 connected to Analyzer / Receiver and Line 2 connected to a 50 ohm load; the second scan had Line 1 connected to a 50 ohm load and Line 2 connected to the Analyzer / Receiver.
- 7 Analyzer / Receiver scanned from 150 KHz to 30MHz for emissions in each of the test modes.
- 8 During the above scans, the emissions were maximized by cable manipulation.

Conducted Power Line Emission Limit

For intentional device, according to § 15.207(a) and RSS-Gen Section 7.2.4 for AC Power Conducted Emission Limits is as following:

Frequency (MHz)	Maximum RF Line Voltage (dBμV)			
	CLASS A		CLASS B	
	Q.P.	Ave.	Q.P.	Ave.
0.15 - 0.50	79	66	66-56*	56-46*
0.50 - 5.00	73	60	56	46
5.00 - 30.0	73	60	60	50

* Decreasing linearly with the logarithm of the frequency

TEST RESULTS

Remark: we tested all Op 1 to Op 6, recorded worst case at Op 1.

Test mode:	Op 1	Polarization	+
------------	------	--------------	---

SCAN TABLE: "Voltage (9K-30M) FIN"

Short Description: 150K-30M Voltage

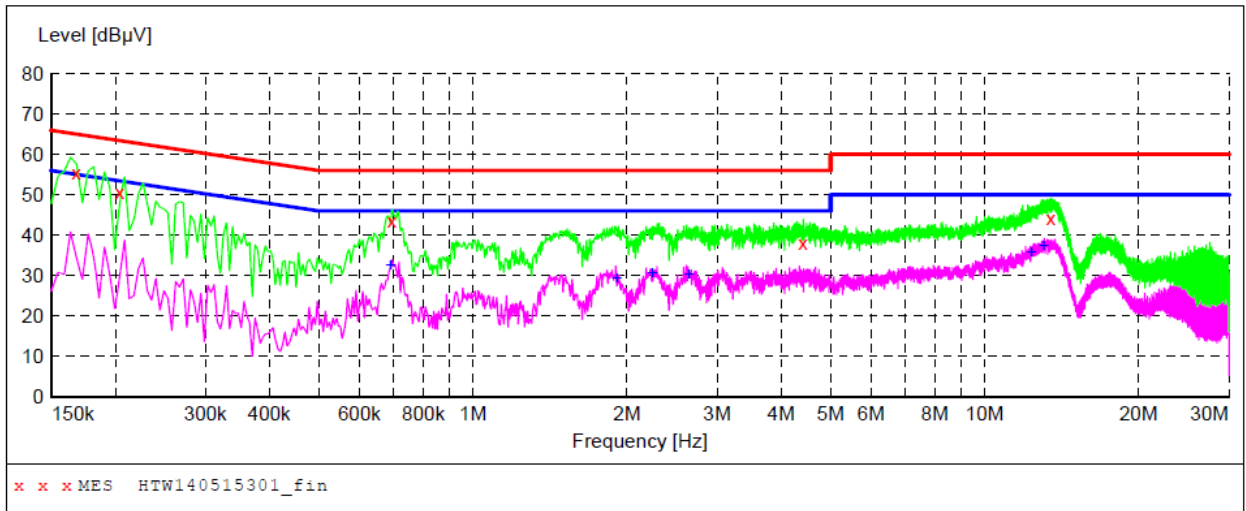

MEASUREMENT RESULT: "HTW140515301_fin"

05/15/2014 9:53AM

Frequency MHz	Level dBµV	Transd dB	Limit dBµV	Margin dB	Detector	Line	PE
0.168000	55.30	10.1	65	9.8	QP	+	GND
0.204000	50.70	10.1	63	12.7	QP	+	GND
0.694500	43.40	10.2	56	12.6	QP	+	GND
4.416000	38.10	10.3	56	17.9	QP	+	GND
13.479000	44.30	10.6	60	15.7	QP	+	GND

MEASUREMENT RESULT: "HTW140515301_fin2"

05/15/2014 9:53AM

Frequency MHz	Level dBµV	Transd dB	Limit dBµV	Margin dB	Detector	Line	PE
0.690000	32.60	10.2	46	13.4	AV	+	GND
1.909500	29.40	10.3	46	16.6	AV	+	GND
2.242500	30.60	10.3	46	15.4	AV	+	GND
2.638500	30.20	10.3	46	15.8	AV	+	GND
12.336000	35.80	10.6	50	14.2	AV	+	GND
13.033500	37.50	10.6	50	12.5	AV	+	GND

Test mode:	Op 1	Polarization	-
------------	------	--------------	---

SCAN TABLE: "Voltage (9K-30M) FIN"

Short Description: 150K-30M Voltage

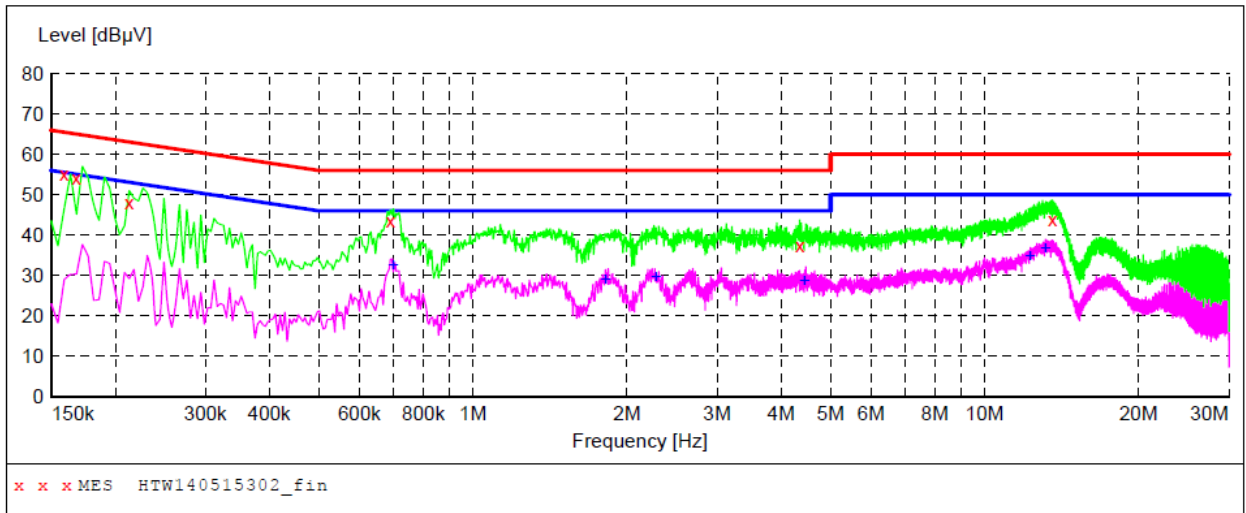

MEASUREMENT RESULT: "HTW140515302_fin"

05/15/2013 9:56AM

Frequency MHz	Level dBµV	Transd dB	Limit dBµV	Margin dB	Detector	Line	PE
0.159000	55.10	10.1	66	10.4	QP	-	GND
0.168000	54.00	10.1	65	11.1	QP	-	GND
0.213000	48.20	10.1	63	14.9	QP	-	GND
0.690000	43.60	10.2	56	12.4	QP	-	GND
4.357500	37.40	10.3	56	18.6	QP	-	GND
13.587000	43.90	10.6	60	16.1	QP	-	GND

MEASUREMENT RESULT: "HTW140515302_fin2"

05/15/2013 9:56AM

Frequency MHz	Level dBµV	Transd dB	Limit dBµV	Margin dB	Detector	Line	PE
0.699000	32.50	10.2	46	13.5	AV	-	GND
1.815000	29.10	10.3	46	16.9	AV	-	GND
2.274000	29.80	10.3	46	16.2	AV	-	GND
4.438500	28.70	10.3	46	17.3	AV	-	GND
12.246000	34.70	10.6	50	15.3	AV	-	GND
13.105500	36.70	10.6	50	13.3	AV	-	GND

4.2. Maximum Transmitter Power

TEST APPLICABLE

Pursuant 47 CFR 2.1046(a), 2.1033(c) (6), 2.1033(c) (7) and 2.1033(c) (8), Part 90.205
Part 90.205: Maximum ERP is dependent upon the station's antenna HAAT and required service area

TEST CONFIGURATION

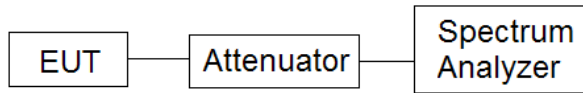

TEST PROCEDURE

- 1 Measurements shall be made to establish the radio frequency power delivered by the transmitter the standard output termination. The power output shall be monitored and recorded and no adjustment shall be made to the transmitter after the test has begun, except as noted below:
- 2 If the power output is adjustable, measurements shall be made for the highest and lowest power levels.
- 3 The EUT connect to the Receiver through 20 dB attenuator.
- 4 Measurement with Spectrum Analyzer FSP40 conducted, external power supply with 13.60 V stabilized supply voltage.

TEST RESULTS

Maximum rated power			
Modulation Type	Operation Mode	Test channel (MHz)	Measurement Power (dBm)
4FSK	Op 1	410.0	46.10
		440.0	46.02
		470.0	45.54
GMSK	Op 3	410.0	46.01
		440.0	45.99
		470.0	45.57

Minimum rated power			
Modulation Type	Operation Mode	Test channel (MHz)	Measurement Power (dBm)
4FSK	Op 2	410.0	37.09
		440.0	37.30
		470.0	36.94
GMSK	Op 4	410.0	37.46
		440.0	37.31
		470.0	37.26

Rated operation voltage: 12.0V

Test Plots as below:

4FSK Modulation Op 1

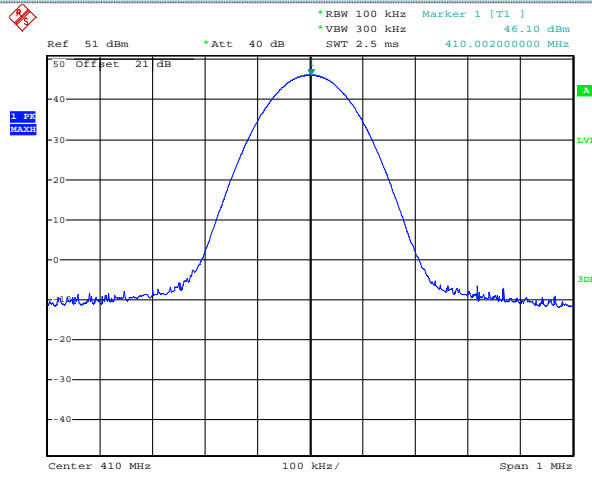

Date: 15.MAY.2014 11:09:26

410.0MHz

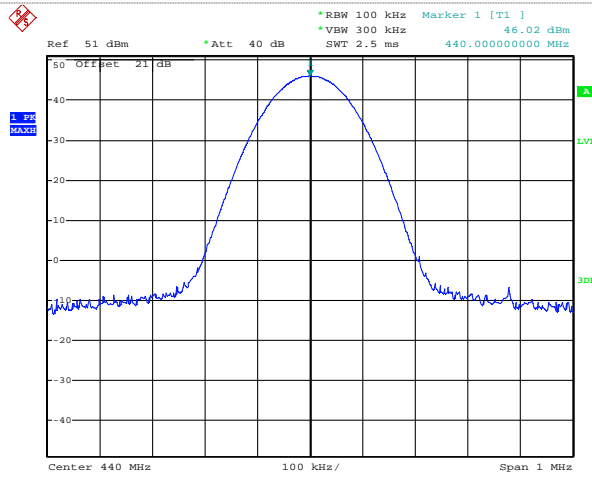

Date: 15.MAY.2014 11:41:28

440.0MHz

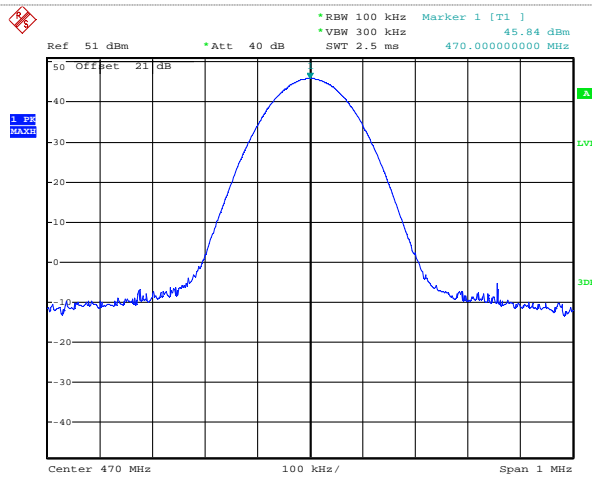

Date: 15.MAY.2014 11:10:53

470.0MHz

4FSK Modulation Op 2

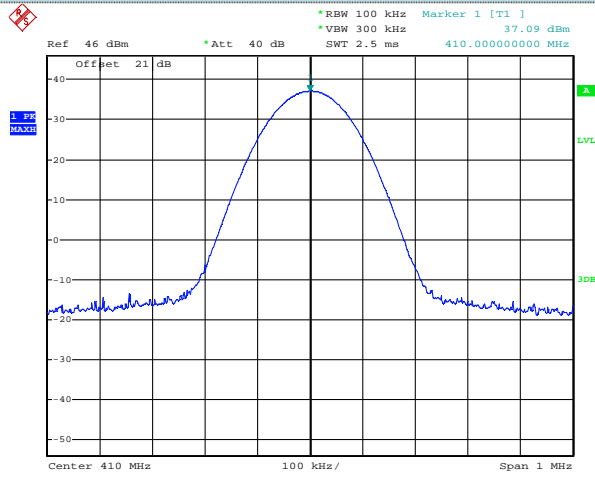

Date: 21.MAY.2014 15:56:25

410.0MHz

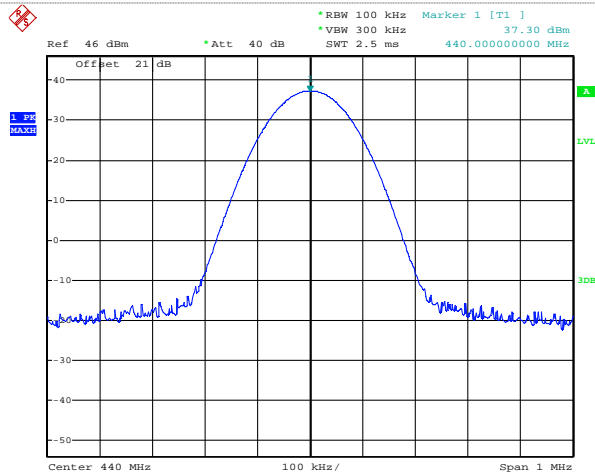

Date: 21.MAY.2014 15:55:23

440.0MHz

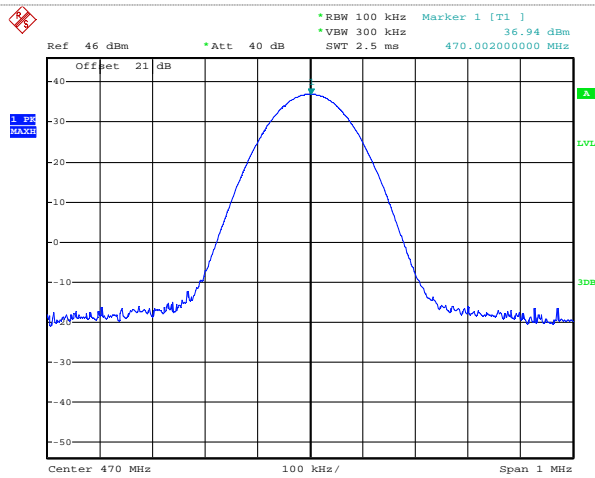

Date: 21.MAY.2014 15:59:03

470.0MHz

GMSK Modulation Op 3

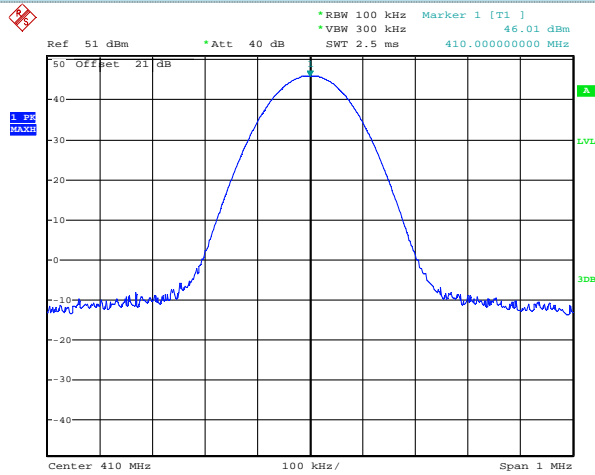

Date: 15.MAY.2014 11:31:11

410.0MHz

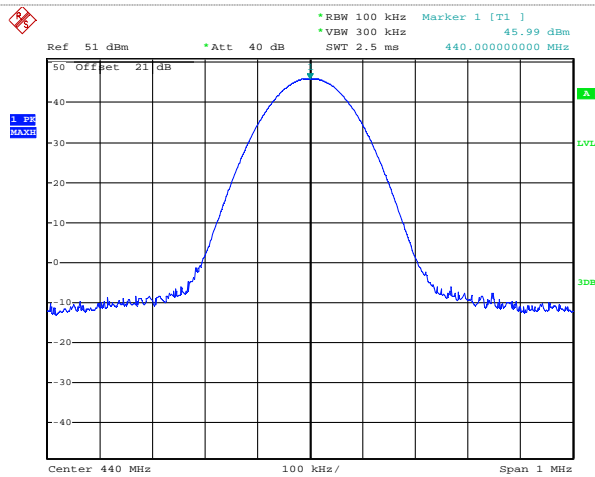

Date: 15.MAY.2014 11:41:37

440.0MHz

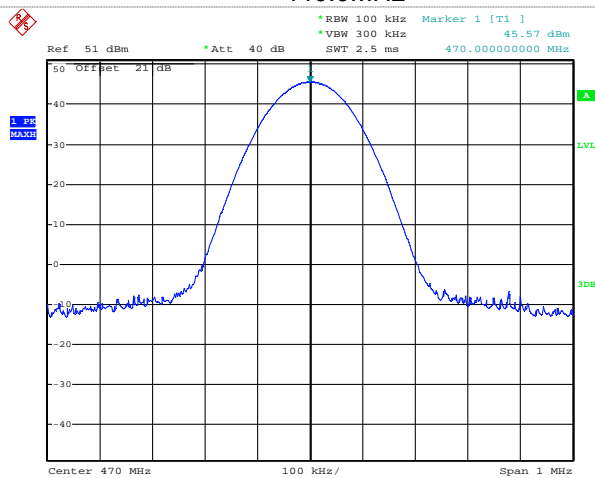

Date: 15.MAY.2014 11:31:50

470.0MHz

GMSK Modulation Op 4

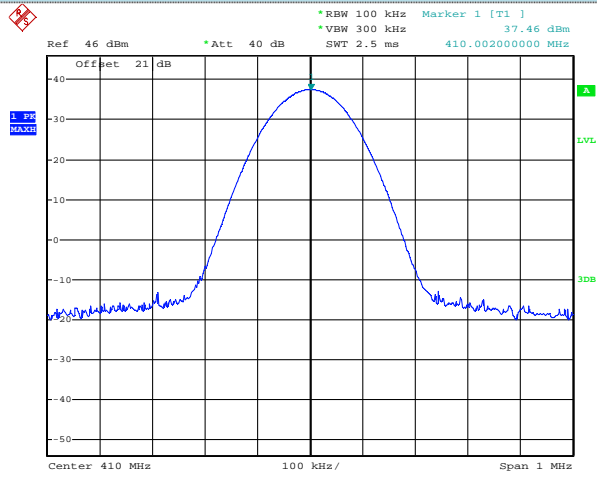

Date: 21.MAY.2014 15:56:36

410.0MHz

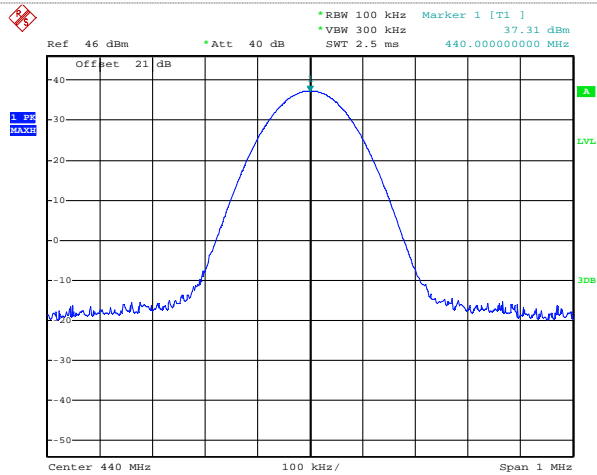

Date: 21.MAY.2014 15:55:13

440.0MHz

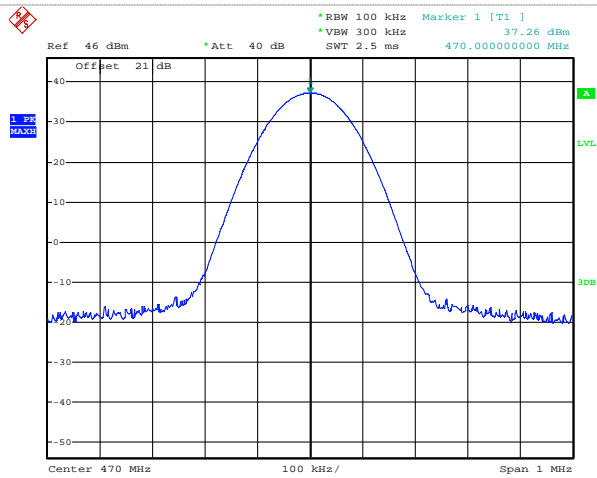

Date: 21.MAY.2014 15:58:57

470.0MHz

4.3. Occupied Bandwidth and Emission Mask Test

TEST APPLICABLE

- a) Occupied Bandwidth: The EUT was connected to the audio signal generator and the spectrum analyzer via the main RF connector, and through an appropriate attenuator. The EUT was controlled to transmit its maximum power. Then the bandwidth of 99% power can be measured by the spectrum analyzer.
- b) Emission Mask B: For transmitters that are equipped with an audio low-pass filter pursuant to §90.211(a), the power of any emission must be below the unmodulated carrier power (P) as follows:
 - 1) On any frequency removed from the assigned frequency by more than 50 percent, but not more than 100 percent of the authorized bandwidth: At least 25 dB.
 - 2) On any frequency removed from the assigned frequency by more than 100 percent, but not more than 250 percent of the authorized bandwidth: At least 35 dB.
 - 3) On any frequency removed from the assigned frequency by more than 250 percent of the authorized bandwidth: At least $43 + 10 \log (P)$ dB.
- c) Emission Mask D, 12.5 kHz channel bandwidth equipment: For transmitters designed to operate with a 12.5 kHz channel bandwidth, any emission must be attenuated below the power (P) of the highest emission contained within the authorized bandwidth as follows:
 - 1) On any frequency from the center of the authorized bandwidth f_0 to 5.625 kHz removed from f_0 : Zero dB.
 - 2) On any frequency removed from the center of the authorized bandwidth by a displacement frequency (f_d in kHz) of more than 5.625 kHz but no more than 12.5 kHz: At least $7.27(f_d - 2.88 \text{ kHz})$ dB.
 - 3) On any frequency removed from the center of the authorized bandwidth by a displacement frequency (f_d in kHz) of more than 12.5 kHz: At least $50 + 10 \log (P)$ dB or 70 dB, whichever is the lesser attenuation.

TEST CONFIGURATION

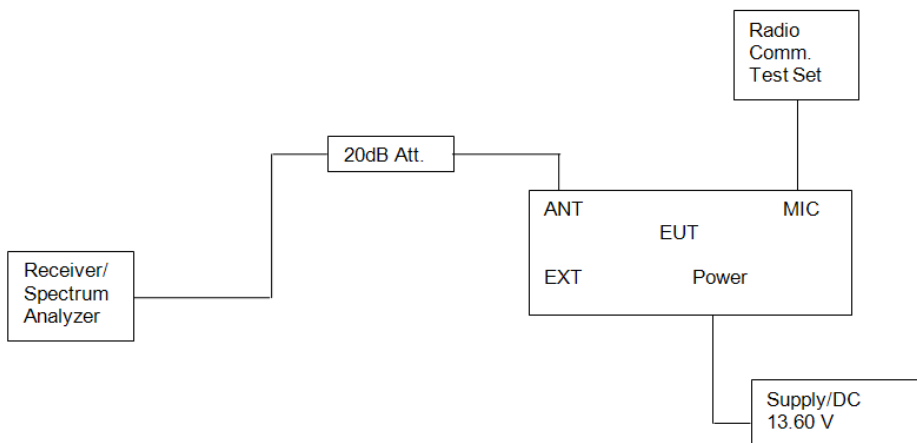

TEST PROCEDURE

- 1 The EUT was placed on a turn table which is 0.8m above ground plane.
- 2 The EUT was modulated by 2.5 KHz Sine wave audio signal; the level of the audio signal employed is 16 dB greater than that necessary to produce 50% of rated system deviation. Rated system deviation is 2.5 kHz (12.5 kHz channel spacing) and 5 kHz (25 kHz channel spacing).
- 3 Spectrum analyzer set as follow:
Center Frequency = fundamental frequency, RBW=300Hz, VBW= 3 KHz, span =50 KHz.
Decetor=peak, Set 99% Occupied Bandwidth and 26dB Occupied Bandwidth.

TEST RESULTS

Occupied Bandwidth

Modulation type	Operation Mode	Test Channel (MHz)	Occupied Bandwidth (KHz)		Limit (KHz)	Result
			99%	26dB		
4FSK	Op 1	410.0	8.40	10.06	11.25	Pass
		440.0	8.60	11.20		
		470.0	8.40	10.70		
	Op 2	410.0	8.50	10.40		
		440.0	8.80	11.20		
		470.0	8.80	10.80		
GMSK	Op 3	410.0	5.04	6.24	11.25	Pass
		440.0	5.08	6.12		
		470.0	5.08	6.12		
	Op 4	410.0	4.98	6.12		
		440.0	4.98	6.18		
		470.0	5.10	6.18		

4FSK Modulation Op 1

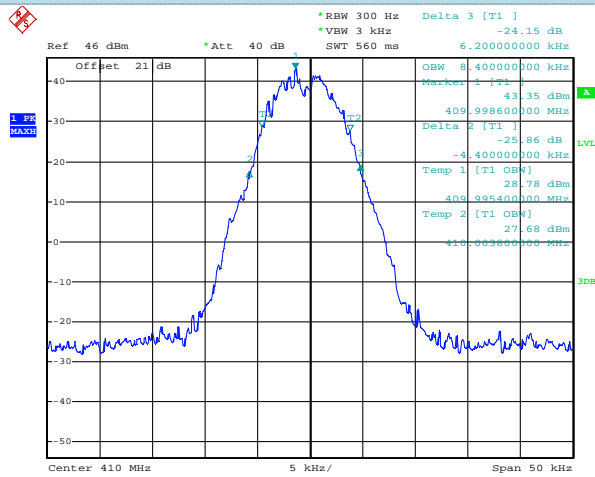

Date: 21.MAY.2014 15:10:04

410.0MHz

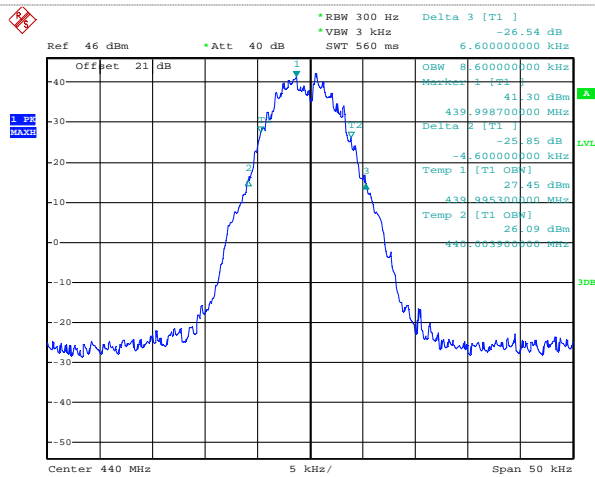

Date: 21.MAY.2014 15:11:05

440.0MHz

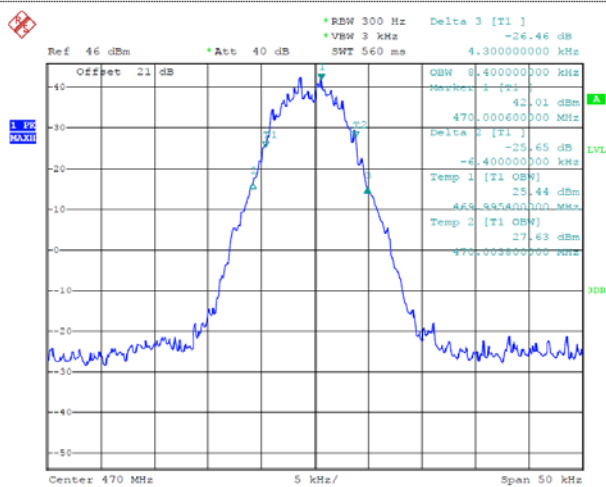

Date: 21.MAY.2014 15:07:59

470.0MHz

4FSK Modulation Op 2

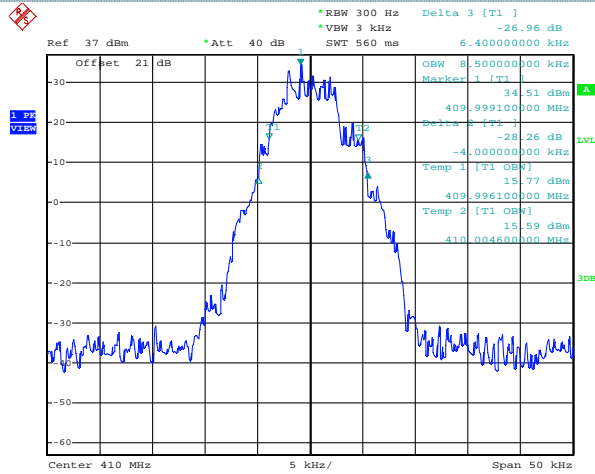

Date: 23.JUN.2014 16:21:50

410.0MHz

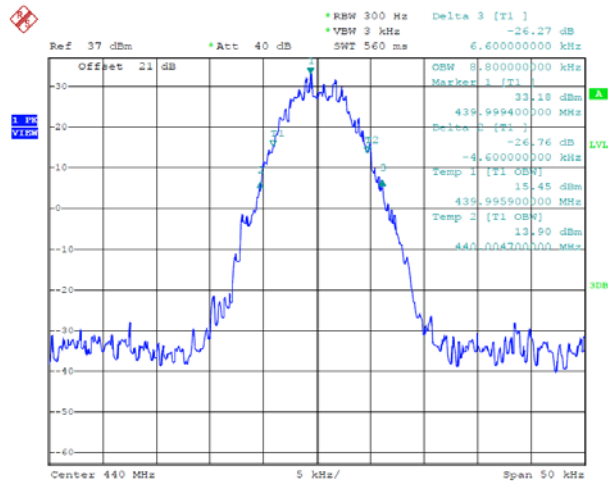

Date: 23.JUN.2014 16:18:07

440.0MHz

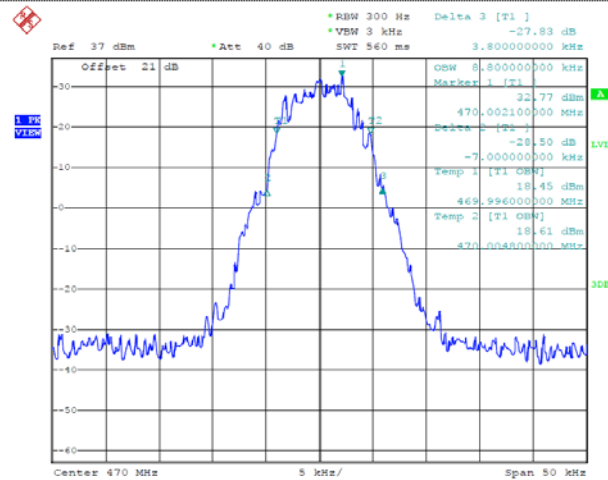

Date: 23.JUN.2014 16:14:29

470.0MHz

GMSK Modulation Op 3

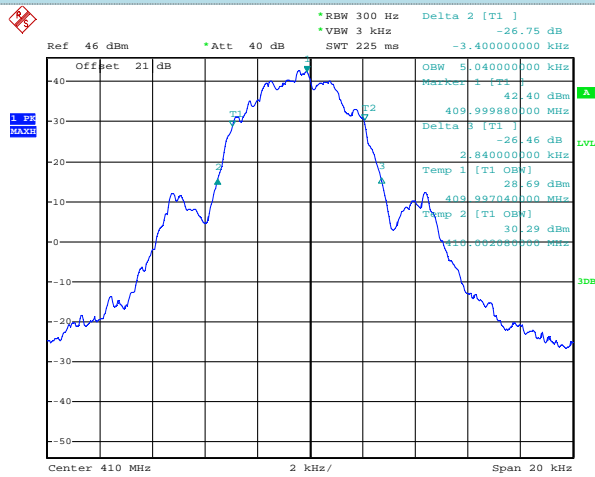

Date: 21.MAY.2014 15:16:49

410.0MHz

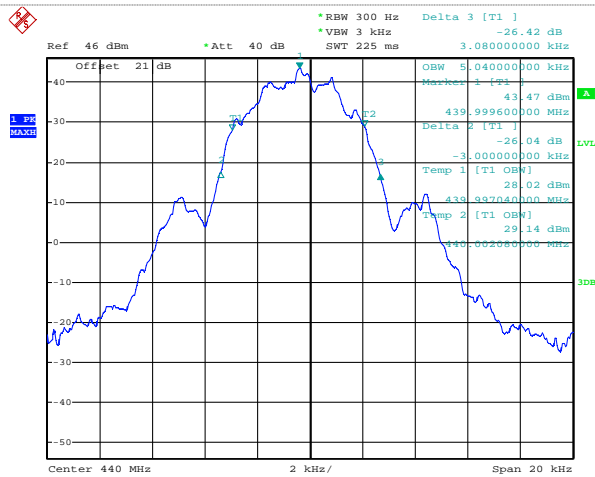

Date: 21.MAY.2014 15:17:48

440.0MHz

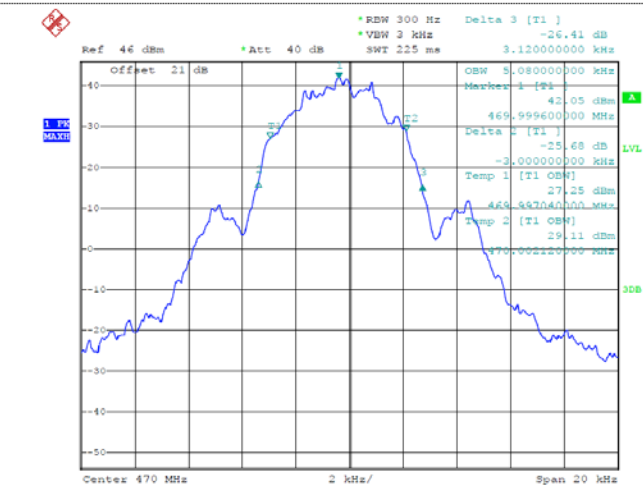

Date: 21.MAY.2014 15:19:53

470.0MHz

GMSK Modulation Op 4

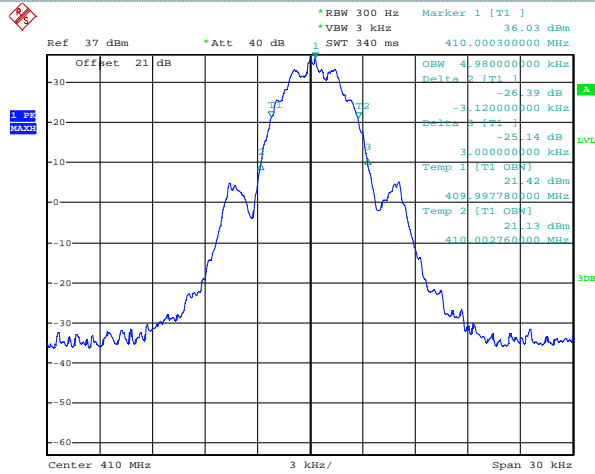

Date: 23.JUN.2014 15:49:20

410.0MHz

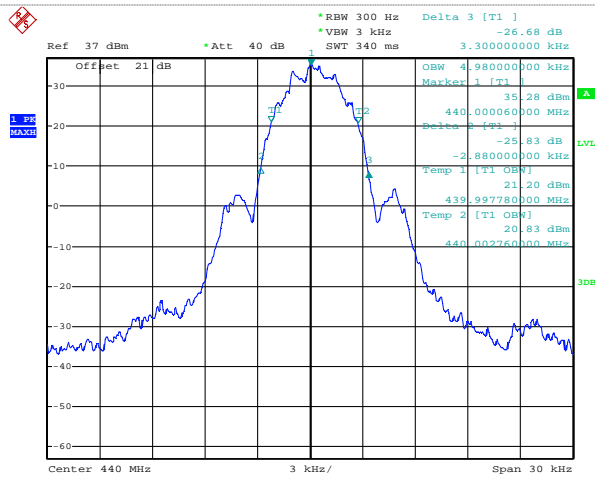

Date: 23.JUN.2014 15:53:17

440.0MHz

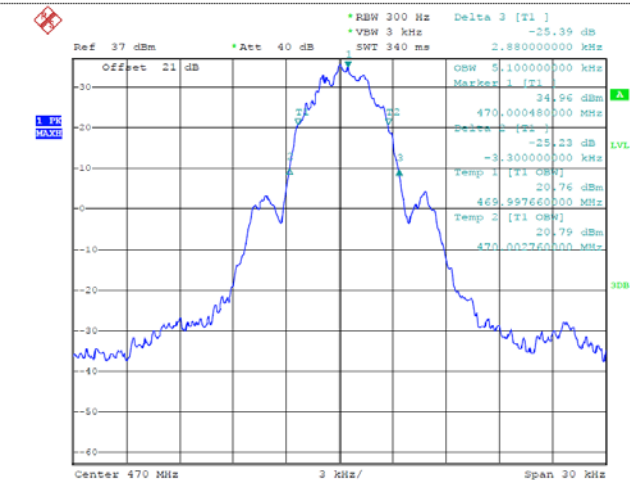

Date: 23.JUN.2014 15:57:16

470.0MHz

Emission Mask

4FSK Modulation Op 1

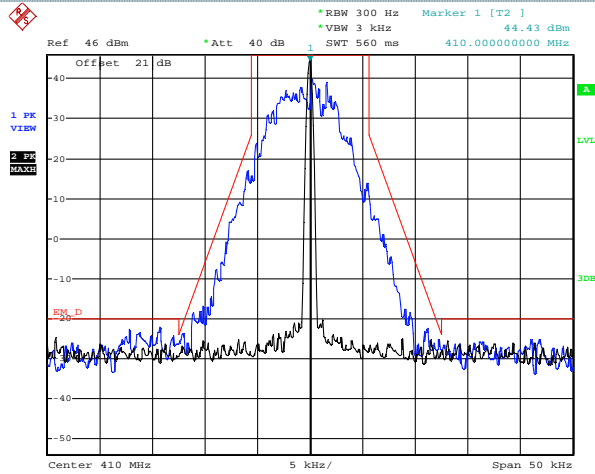

Date: 21.MAY.2014 14:50:31

410.0MHz

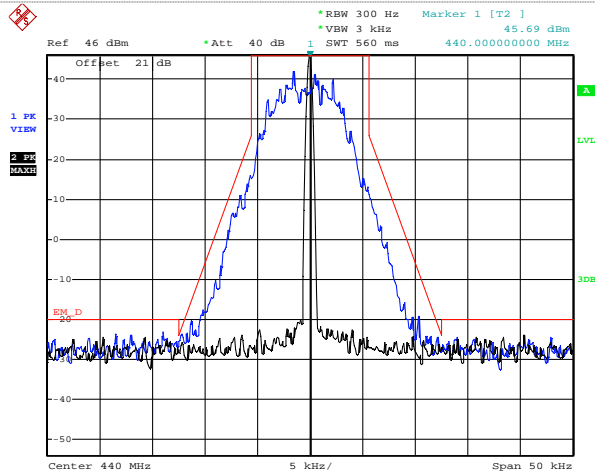

Date: 21.MAY.2014 14:53:20

440.0MHz

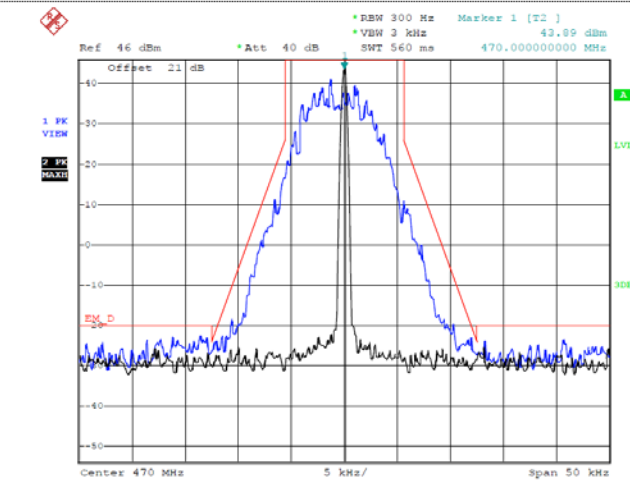

Date: 21.MAY.2014 15:06:51

470.0MHz

4FSK Modulation Op 2

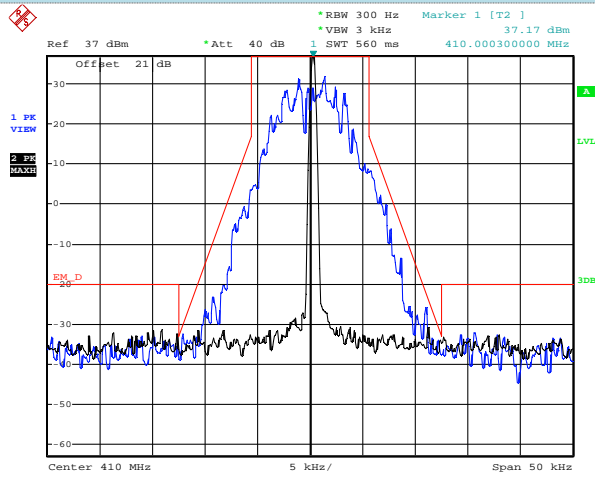

Date: 23.JUN.2014 16:23:04

410.0MHz

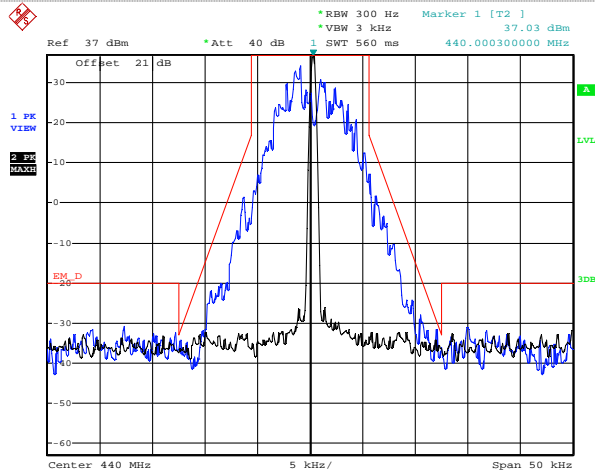

Date: 23.JUN.2014 16:19:53

440.0MHz

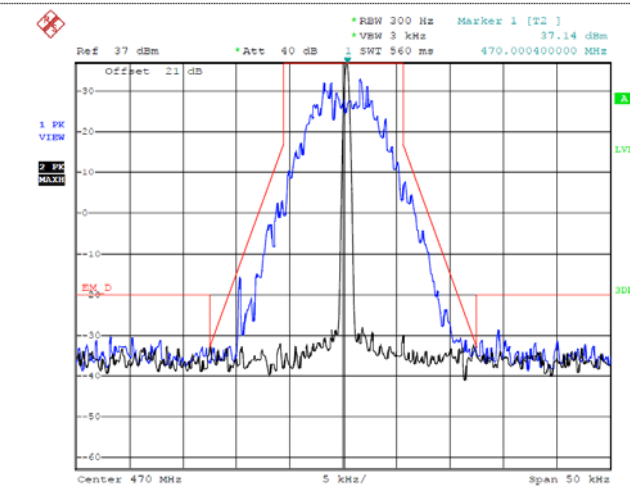

Date: 23.JUN.2014 16:16:00

470.0MHz

GMSK Modulation Op 3

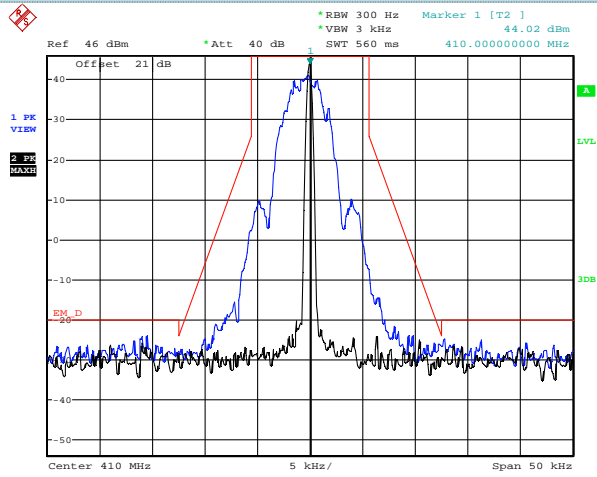

Date: 21.MAY.2014 15:22:13

410.0MHz

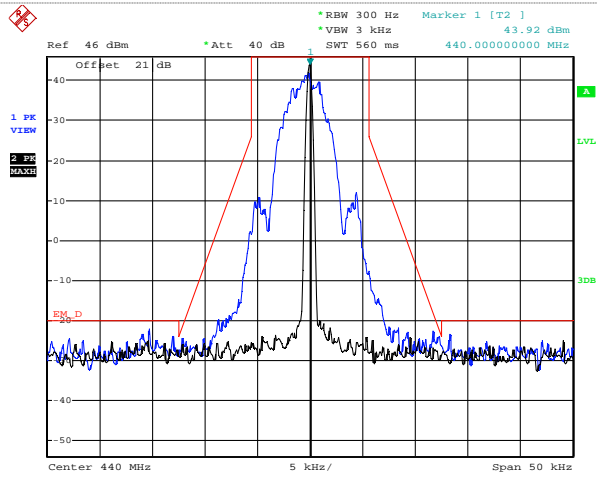

Date: 21.MAY.2014 15:23:40

440.0MHz

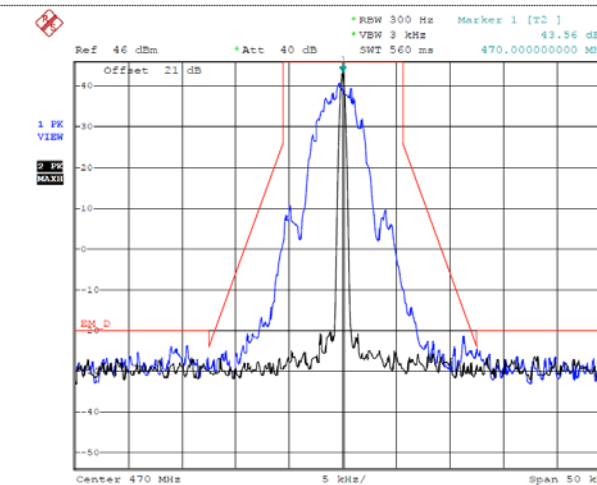

Date: 21.MAY.2014 15:21:10

470.0MHz

GMSK Modulation Op 4

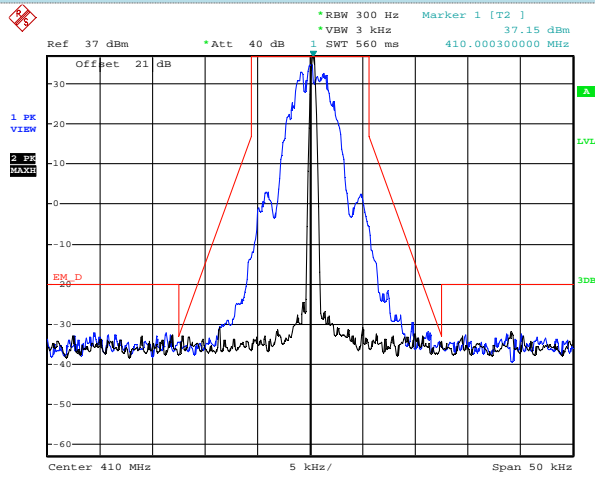

Date: 23.JUN.2014 15:52:13

410.0MHz

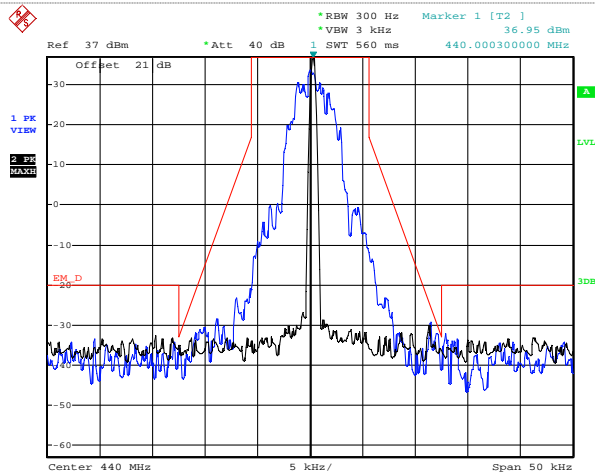

Date: 23.JUN.2014 15:55:14

440.0MHz

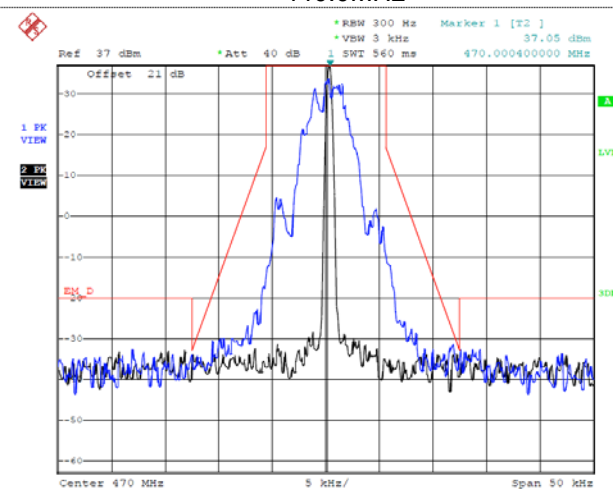

Date: 23.JUN.2014 16:02:53

470.0MHz

Note:
Black curve: Unmodulated signal, Blue curve: Modulated signal

4.4. Frequency Stability Test

TEST APPLICABLE

- 1 According to FCC Part 2 Section 2.1055 (a)(1), the frequency stability shall be measured with variation of ambient temperature from -30°C to +60°C centigrade.
- 2 According to FCC Part 2 Section 2.1055 (d) (2), for battery powered equipment, the frequency stability shall be measured with reducing primary supply voltage to the battery operating end point, which is specified by the manufacture.
- 3 Vary primary supply voltage from 85 to 115 percent of the nominal value.
- 4 According to §90.213, the frequency stability limit is 2.5 ppm for 12.5KHz channel separation

TEST CONFIGURATION

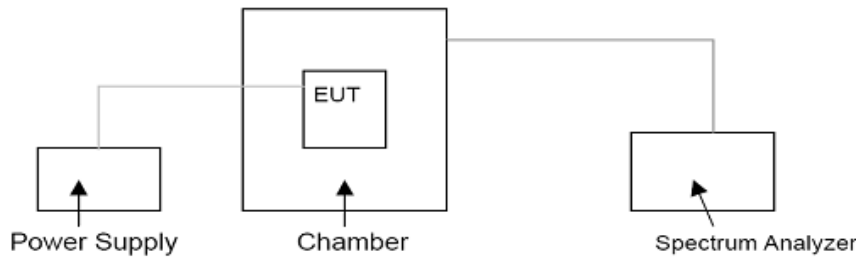

TEST PROCEDURE

- 1 The EUT was set in the climate chamber and connected to an external DC power supply.
- 2 The RF output was directly connected to Spectrum Analyzer ESI 26. The coupling loss of the additional cables was recorded and taken in account for all the measurements.
- 3 After temperature stabilization (approx. 20 min for each stage), the frequency for the lower, the middle and the highest frequency range was recorded.
- 4 For Frequency stability Vs. Voltage the EUT was connected to a DC power supply and the voltage was adjusted in the required ranges. The result was recorded.

TEST LIMITS

According to 90.213, Transmitters used must have minimum frequency stability as specified in the following table.

Frequency Range (MHz)	Channel Bandwidth (KHz)	Frequency Tolerance (ppm)		
		Fixed and Base Stations	Mobile Stations	
			> 2 W	≤ 2 W
150-174 MHz	6.25	1.0	2.0	2.0
	12.5	2.5	5.0	5.0
	25	5.0	5.0	50.0*
421-512 MHz	6.25	0.5	1.0	1.0
	12.5	1.5	2.5	2.5
	25	2.5	5.0	5.0

- Stations operating in the 154.45 to 154.49 MHz or the 173.2 to 173.4 MHz bands must have a frequency stability of 5 ppm.
- Paging transmitters operating on paging-only frequencies must operate with frequency stability of 5 ppm in the 150-174 MHz band and 2.5 ppm in the 421-512 MHz band.

TEST RESULTS

4FSK Modulation Op 1						
Voltage (DC)	Channel (MHz)	Temperature (°C)	Frequency error		Limit (ppm)	Result
			Hz	ppm		
3.30	410.0	-30	-179	0.437	1.5	Pass
		-20	-187	0.456		
		-10	-186	0.454		
		0	-196	0.478		
		10	-191	0.466		
		20	-183	0.446		
		30	-196	0.478		
		40	-187	0.456		
		50	-189	0.461		
	440.0	-30	-287	0.652	1.5	Pass
		-20	-283	0.643		
		-10	-315	0.716		
		0	-306	0.695		
		10	-284	0.645		
		20	-289	0.657		
		30	-288	0.655		
		40	-337	0.766		
		50	-326	0.741		
	470.0	-30	-408	0.868	1.5	Pass
		-20	-419	0.891		
		-10	-426	0.906		
		0	-409	0.870		
		10	-413	0.879		
		20	-412	0.877		
		30	-389	0.828		
		40	-376	0.800		
		50	-374	0.796		

GMSKModulation Op 3						
Voltage (DC)	Channel (MHz)	Temperature (°C)	Frequency error		Limit (ppm)	Result
			Hz	ppm		
3.30	410.0	-30	-405	0.988	1.5	Pass
		-20	-387	0.944		
		-10	-386	0.941		
		0	-423	1.032		
		10	-468	1.141		
		20	-391	0.954		
		30	-387	0.944		
		40	-403	0.983		
		50	-412	1.005		
	440.0	-30	-443	1.007	1.5	Pass
		-20	-428	0.973		
		-10	-424	0.964		
		0	-427	0.970		
		10	-454	1.032		
		20	-440	1.000		
		30	-446	1.014		
		40	-454	1.032		
		50	-449	1.020		
	470.0	-30	-126	0.268	1.5	Pass
		-20	-118	0.251		
		-10	-131	0.279		
		0	-128	0.272		
		10	-125	0.266		
		20	-124	0.264		
		30	-117	0.249		
		40	-111	0.236		
		50	-134	0.285		

4.5. Transmitter Frequency Behavior

TEST APPLICABLE

Section 90.214

Transient frequencies must be within the maximum frequency difference limits during the time intervals indicated:

Time intervals ^{1, 2}	Maximum frequency difference ³	All equipment	
		150 to 174 MHz	421 to 512MHz
Transient Frequency Behavior for Equipment Designed to Operate on 25 KHz Channels			
t ₁ ⁴	± 25.0 KHz	5.0 ms	10.0 ms
t ₂	± 12.5 KHz	20.0 ms	25.0 ms
t ₃ ⁴	± 25.0 KHz	5.0 ms	10.0 ms
Transient Frequency Behavior for Equipment Designed to Operate on 12.5 KHz Channels			
t ₁ ⁴	± 12.5 KHz	5.0 ms	10.0 ms
t ₂	± 6.25 KHz	20.0 ms	25.0 ms
t ₃ ⁴	± 12.5 KHz	5.0 ms	10.0 ms
Transient Frequency Behavior for Equipment Designed to Operate on 6.25 KHz Channels			
t ₁ ⁴	±6.25 KHz	5.0 ms	10.0 ms
t ₂	±3.125 KHz	20.0 ms	25.0 ms
t ₃ ⁴	±6.25 KHz	5.0 ms	10.0 ms

- t_{on} is the instant when a 1 KHz test signal is completely suppressed, including any capture time due to phasing.
t₁ is the time period immediately following t_{on}.
t₂ is the time period immediately following t₁.
t₃ is the time period from the instant when the transmitter is turned off until t_{off}.
t_{off} is the instant when the 1 KHz test signal starts to rise.
- During the time from the end of t₂ to the beginning of t₃, the frequency difference must not exceed the limits specified in § 90.213.
- Difference between the actual transmitter frequency and the assigned transmitter frequency.
- If the transmitter carrier output power rating is 6 watts or less, the frequency difference during this time period may exceed the maximum frequency difference for this time period.

TEST CONFIGURATION

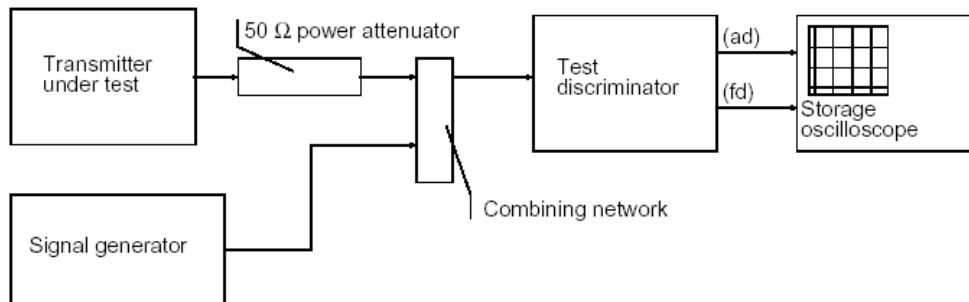

TEST PROCEDURE

According to TIA/EIA-603 2.2.19 requirement. As for the product different from PTT, we use test steps as follows:

- Connect DUT into Test discriminator and Storage Oscilloscope and keep DUT stats ON;
- Inut 1KHz signal into DUT;
- Set the modulation domain analyzer to trigger on the rising edge of the waveform in order to capture a single-shot turn-on of the transmitter signals;
- Keep DUT in OFF state and Key the PTT;
- Observe the stored oscilloscope of modulation domain analyzer. The signal trace shall be maintained within the allowable limits during the periods t₁ and t₂, and shall also remain within limits following t₂;
- Adjust the modulation domain anzlyzer to trigger on the falling edge of the transmitter waveform in order to capture a single-shot turn-off transmitter of the transmitter signal.
- Keep the digital portable radio in ON state and Unkey the PTT;
- Observe the stored oscilloscope of modulation domain analyzer. The signal trace shall be maintained within the allowable limits during the period t₃.

TEST RESULTS

Please refer to the following plots.

Modulation Type: 4FSK

Transmitter Frequency Behaviour @ 12.5 KHz Channel Separation-----Off – On

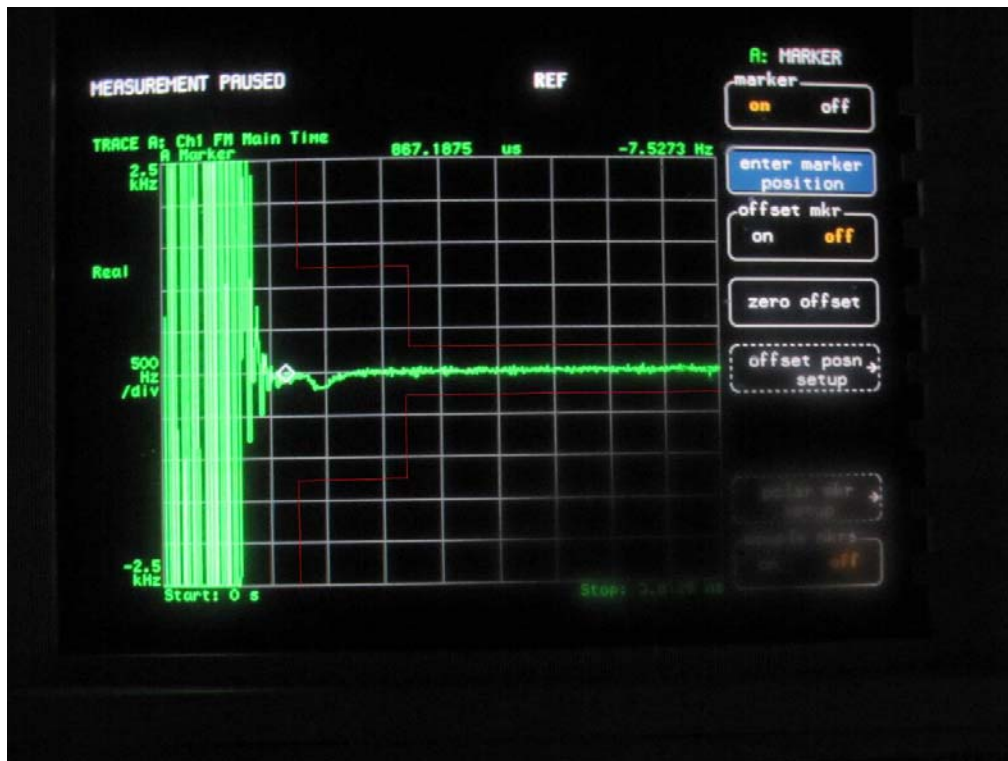

Transmitter Frequency Behaviour @ 12.5 KHz Channel Separation-----On – Off

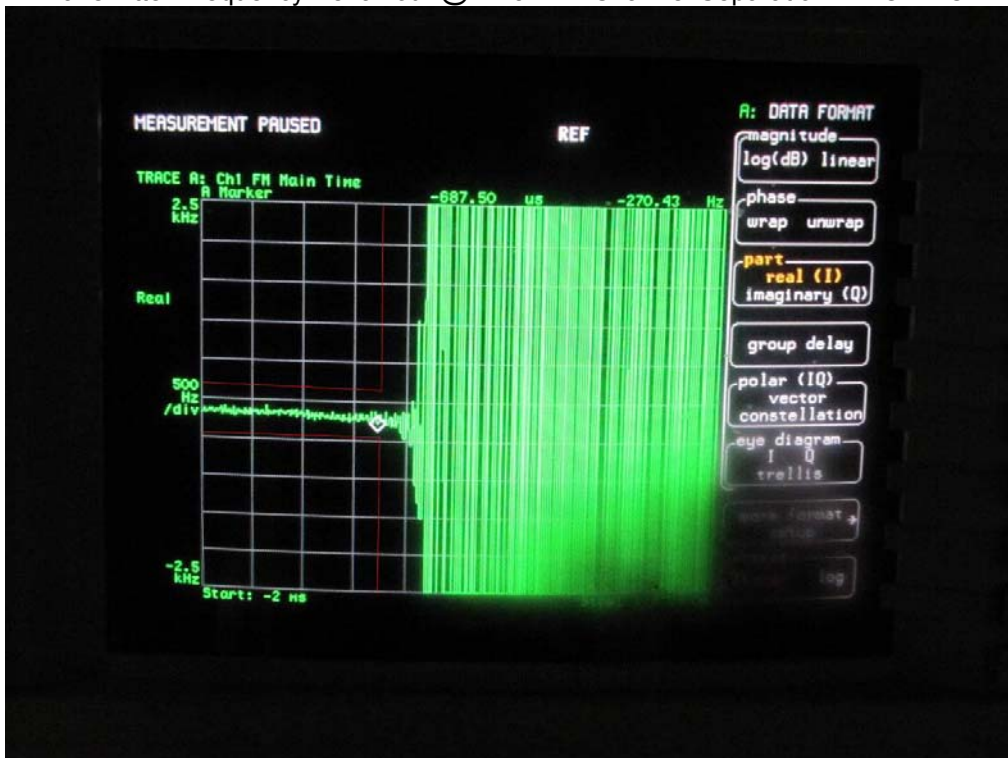

4.6. Spurious Emission on Antenna Port

TEST APPLICABLE

According to the TIA/EIA 603 test method, and according to Section 90.210, the power of each unwanted emission shall be less than Transmitted Power as specified below for transmitters designed to operate with 12.5KHz channel bandwidth:

- 1 On any frequency removed from the center of the authorized bandwidth f_0 to 5.625 KHz removed from f_0 : Zero dB
- 2 On any frequency removed from the center of the authorized bandwidth by a displacement frequency (f_d in KHz) f_0 of more than 5.625 KHz but no more than 12.5 KHz: At least 7.27dB
- 3 On any frequency removed from the center of the authorized bandwidth by a displacement frequency (f_d in KHz) f_0 of more than 12.5 KHz: At least $50+10 \log (P)$ dB or 70 dB, which ever is lesser attenuation.

For transmitters designed to transmit with 25 KHz channel separation and equipped with an audio low-pass filter, the power of any emission must be attenuated below the unmodulated carrier power (P) as following:

- 1 On any frequency removed from the assigned frequency by more than 50 percent, but no more than 100 percent of the authorized bandwidth: At least 25 dB.
- 2 On any frequency removed from the assigned frequency by more than 100 percent, but no more than 250 percent of the authorized bandwidth: At least 35 dB.
- 3 On any frequency removed from the assigned frequency by more than 250 percent of the authorized bandwidth: At least $43+10\log (P)$ dB.

TEST CONFIGURATION

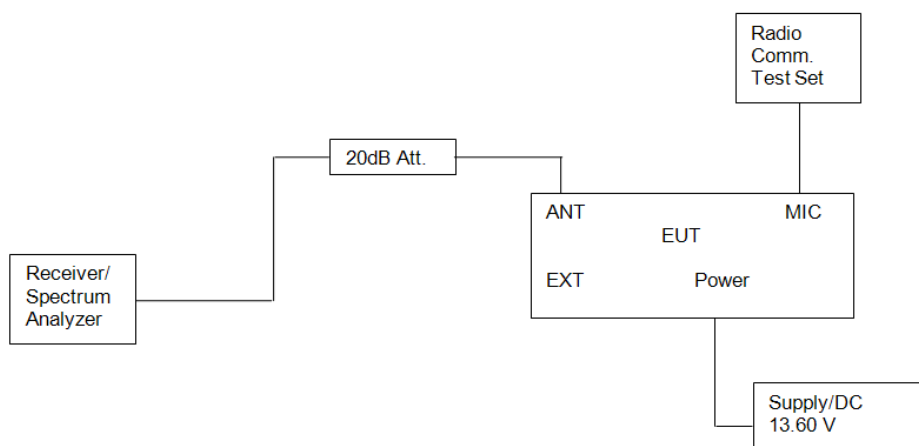

TEST PROCEDURE

- 1 The RF output of the EUT was connected to a spectrum analyzer through appropriate attenuation.
 - 2 The resolution bandwidth of the spectrum analyzer was set to 100 kHz. Sufficient scans were taken to show any out of band emission up to 10th. Harmonic for the lower and the highest frequency range.
 - 3 Set RBW 100 kHz, VBW 300 kHz in the frequency band 30MHz to 1GHz, while set RBW=1MHz. VBW=3MHz from the 1GHz to 10th Harmonic.
- The audio input was set to 0 to get the unmodulated carrier, the resulting picture is print out for each channel separation.

LIMIT**Modulation Type: 4FSK/GMSK**

FCC Part 22.359, 74.462, 80.211 and 90.210 and RSS Gen, RSS 119 Issue 11 (12.5 kHz Bandwidth only):
On any frequency removed from the center of the authorized bandwidth by a displacement frequency (f_d in kHz) of more than 12.5 kHz at least:

Low: $50 + 10 \log(P_{\text{watts}}) = 50 + 10 \log(P)$

High: $50 + 10 \log(P_{\text{watts}}) = 50 + 10 \log(P)$

Note: In general, the worse case attenuation requirement shown above was applied.

Calculation: Limit (dBm) = EL - 50 - 10log₁₀(TP)

Notes:

EL is the emission level of the Output Power expressed in dBm, In this application,

*Limit (dBm) = 10log₁₀(1000*P) - 50 - 10log₁₀(P) = -20 dBm*

Note: 1. In general, the worse case attenuation requirement shown above was applied.

2. The measurement frequency range from 30 MHz to 5 GHz.

3. *** means that the emission level is too low to be measured or at least 20 dB down than the limit.

TEST RESULTS

Modulation type:

4FSK (Op 1)

Test channel:

410.0MHz

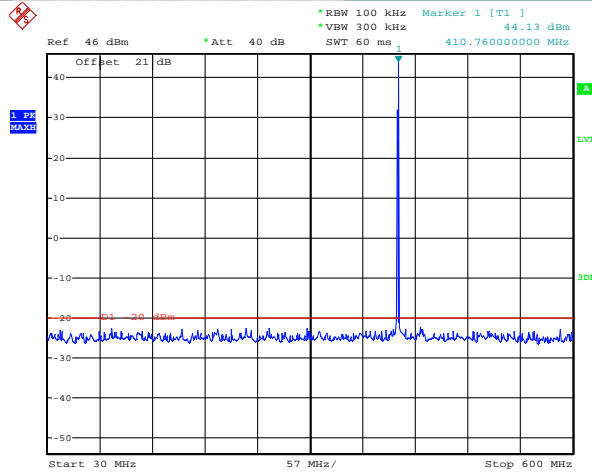

Date: 21.MAY.2014 15:51:33

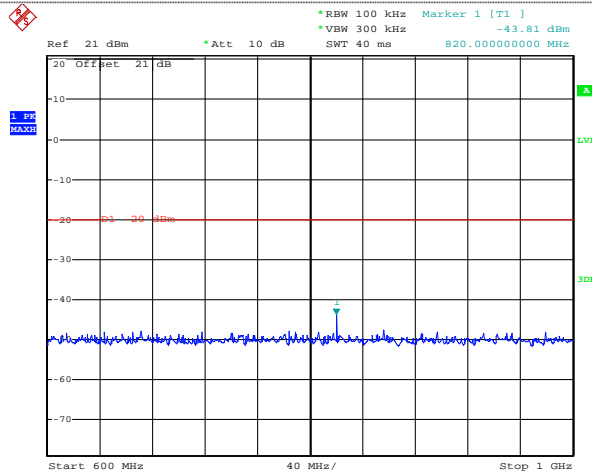

Date: 21.MAY.2014 15:48:32

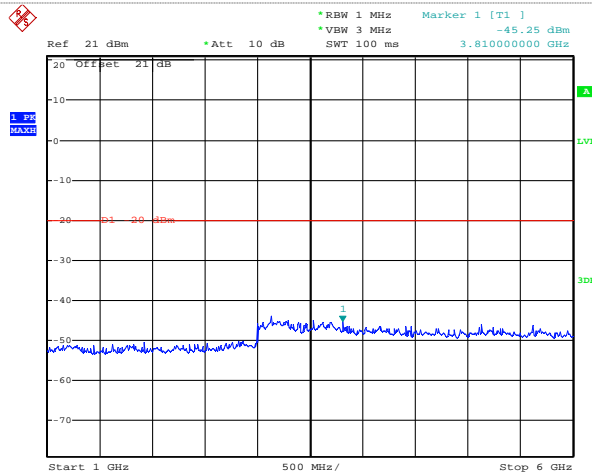

Date: 21.MAY.2014 15:48:50

Modulation type:

4FSK (Op 1)

Test channel:

440.0MHz

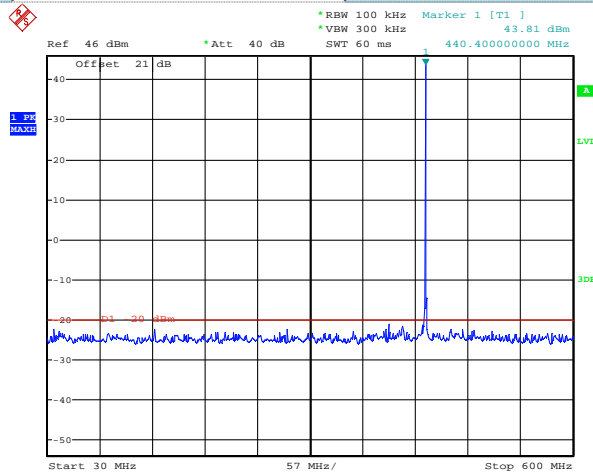

Date: 21.MAY.2014 16:10:09

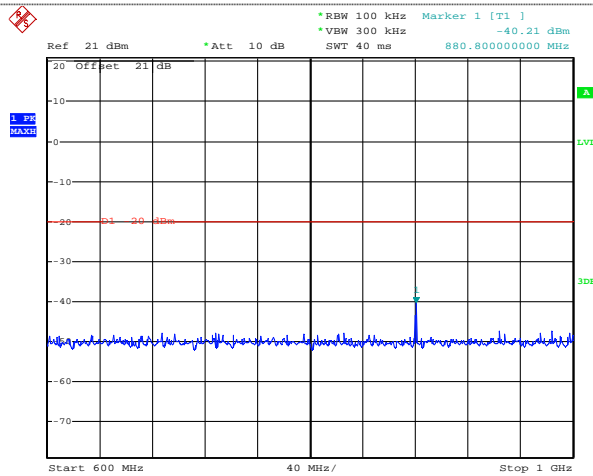

Date: 21.MAY.2014 15:49:29

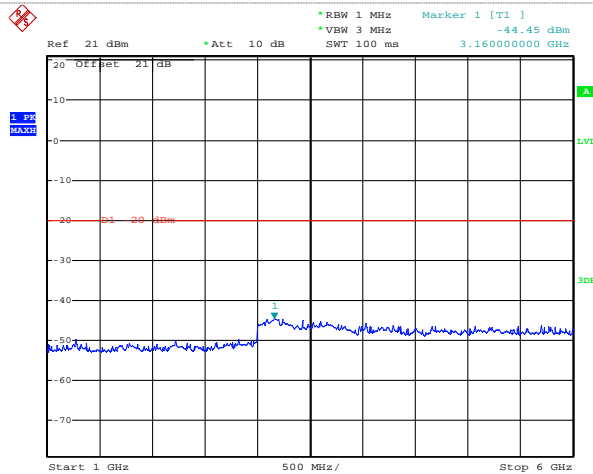

Date: 21.MAY.2014 15:49:10

Modulation type:

4FSK (Op 1)

Test channel:

470.0MHz

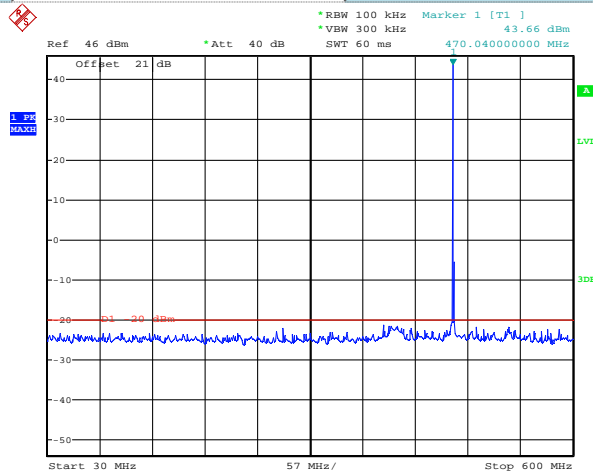

Date: 21.MAY.2014 15:51:15

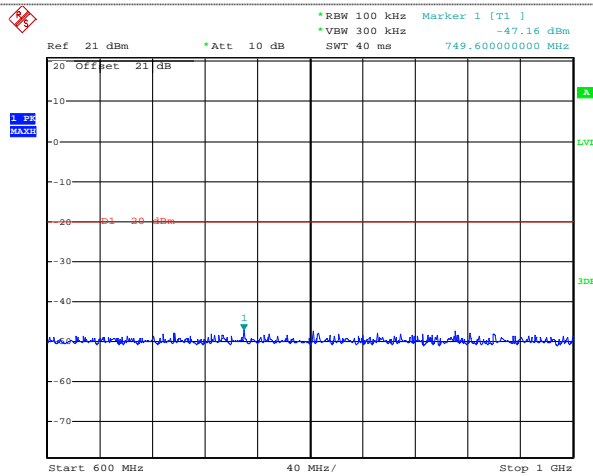

Date: 21.MAY.2014 15:49:45

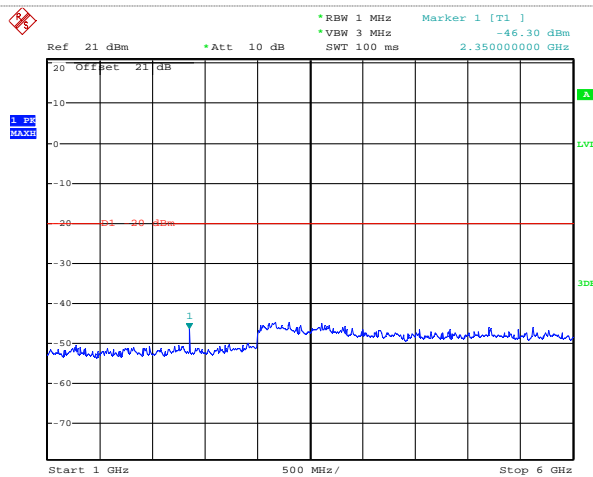

Date: 21.MAY.2014 15:50:03

Modulation type:

GMSK(Op 3)

Test channel:

410.0MHz

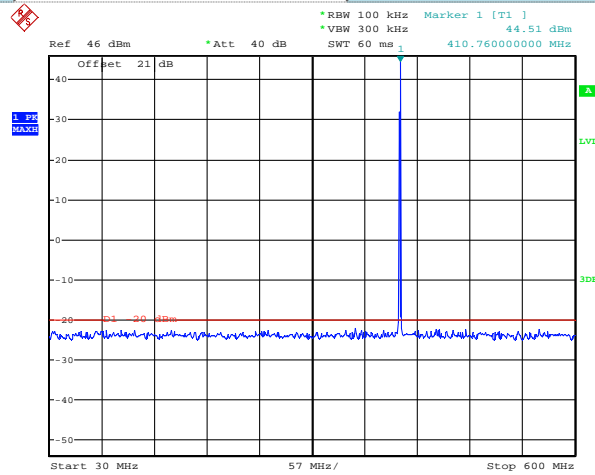

Date: 21.MAY.2014 15:41:31

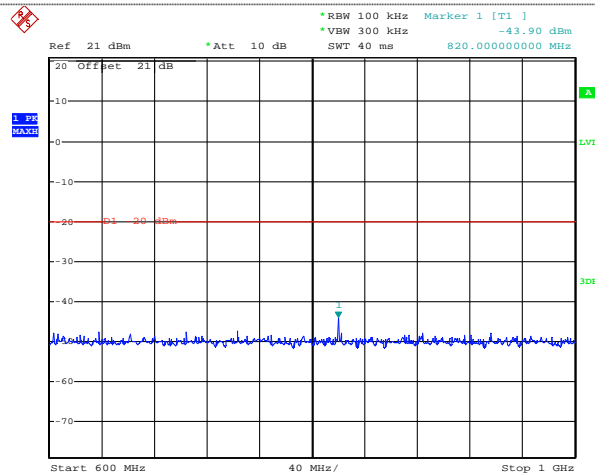

Date: 21.MAY.2014 15:47:19

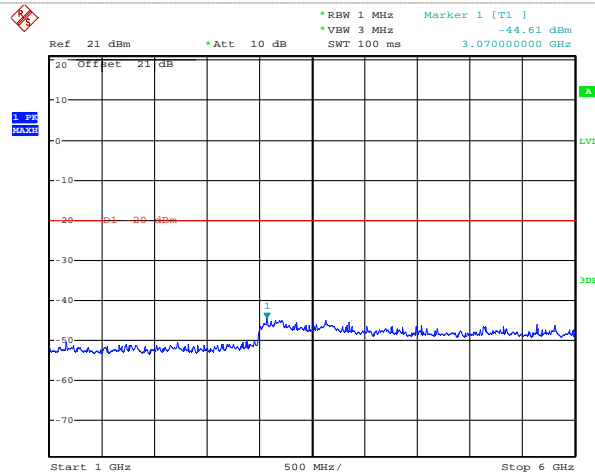

Date: 21.MAY.2014 15:46:58

Modulation type:

GMSK(Op 3)

Test channel:

440.0MHz

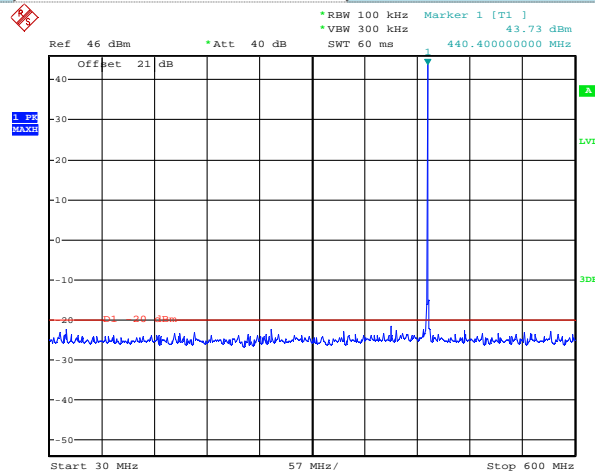

Date: 21.MAY.2014 16:11:16

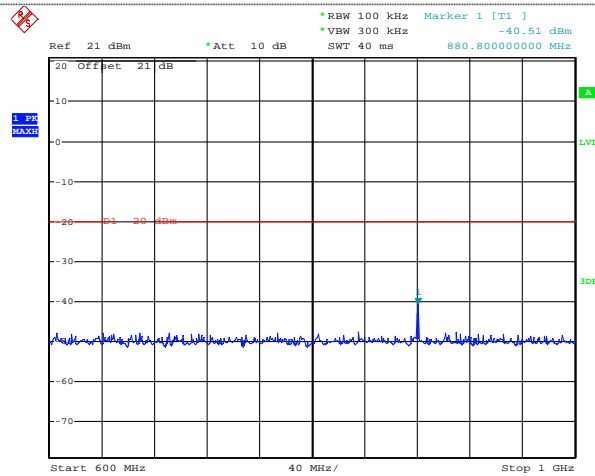

Date: 21.MAY.2014 15:36:47

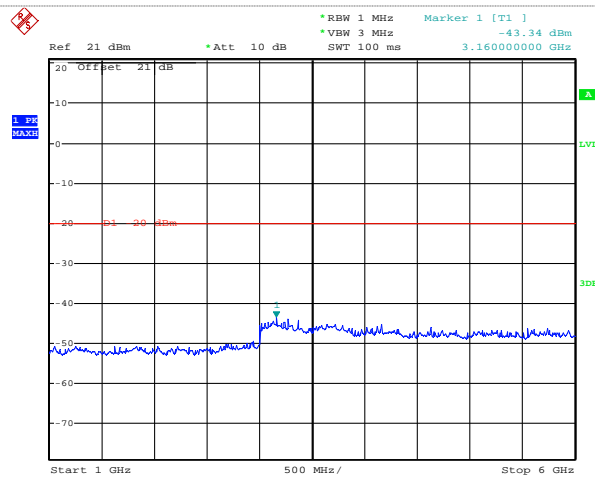

Date: 21.MAY.2014 15:37:25

Modulation type:

GMSK(Op 3)

Test channel:

470.0MHz

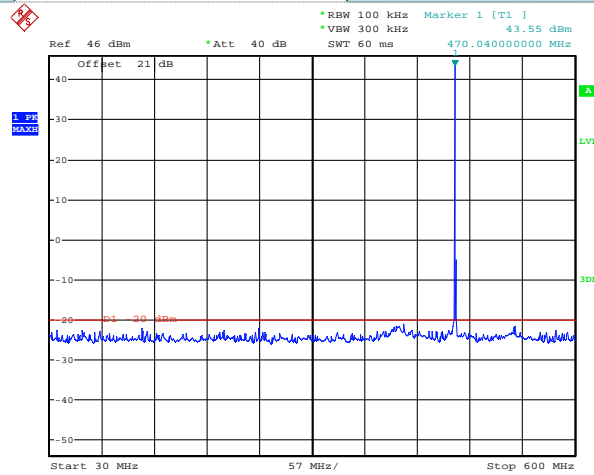

Date: 21.MAY.2014 15:44:17

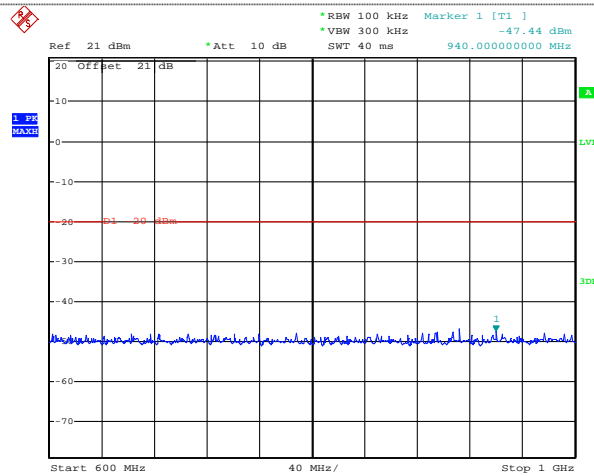

Date: 21.MAY.2014 15:46:15

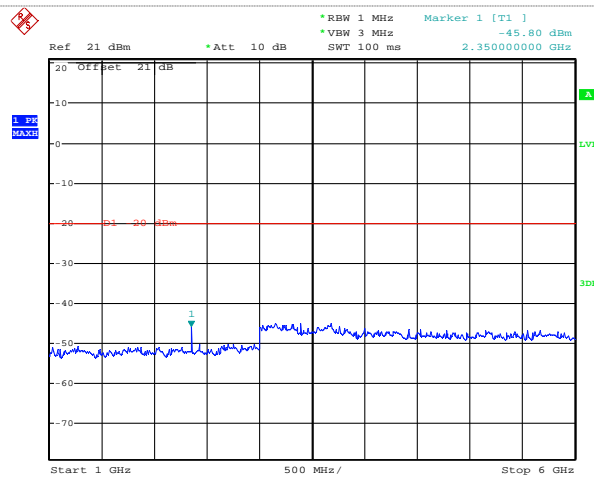

Date: 21.MAY.2014 15:46:33

4.7. Transmitter Radiated Spurious Emission

TEST APPLICABLE

According to the TIA/EIA 603 test method, and according to Section 90.210, the power of each unwanted emission shall be less than Transmitted Power as specified below for transmitters designed to operate with 12.5KHz channel bandwidth:

- 1 On any frequency removed from the center of the authorized bandwidth f_0 to 5.625 KHz removed from f_0 : Zero dB
- 2 On any frequency removed from the center of the authorized bandwidth by a displacement frequency (f_d in KHz) f_0 of more than 5.625 KHz but no more than 12.5 KHz: At least 7.27dB
- 3 On any frequency removed from the center of the authorized bandwidth by a displacement frequency (f_d in KHz) f_0 of more than 12.5 KHz: At least $50+10 \log (P)$ dB or 70 dB, which ever is lesser attenuation.

For transmitters designed to transmit with 25 KHz channel separation and equipped with an audio low-pass filter, the power of any emission must be attenuated below the unmodulated carrier power (P) as following:

- 1 On any frequency removed from the assigned frequency by more than 50 percent, but no more than 100 percent of the authorized bandwidth: At least 25 dB.
- 2 On any frequency removed from the assigned frequency by more than 100 percent, but no more than 250 percent of the authorized bandwidth: At least 35 dB.
- 3 On any frequency removed from the assigned frequency by more than 250 percent of the authorized bandwidth: At least $43+10\log (P)$ dB.

TEST CONFIGURATION

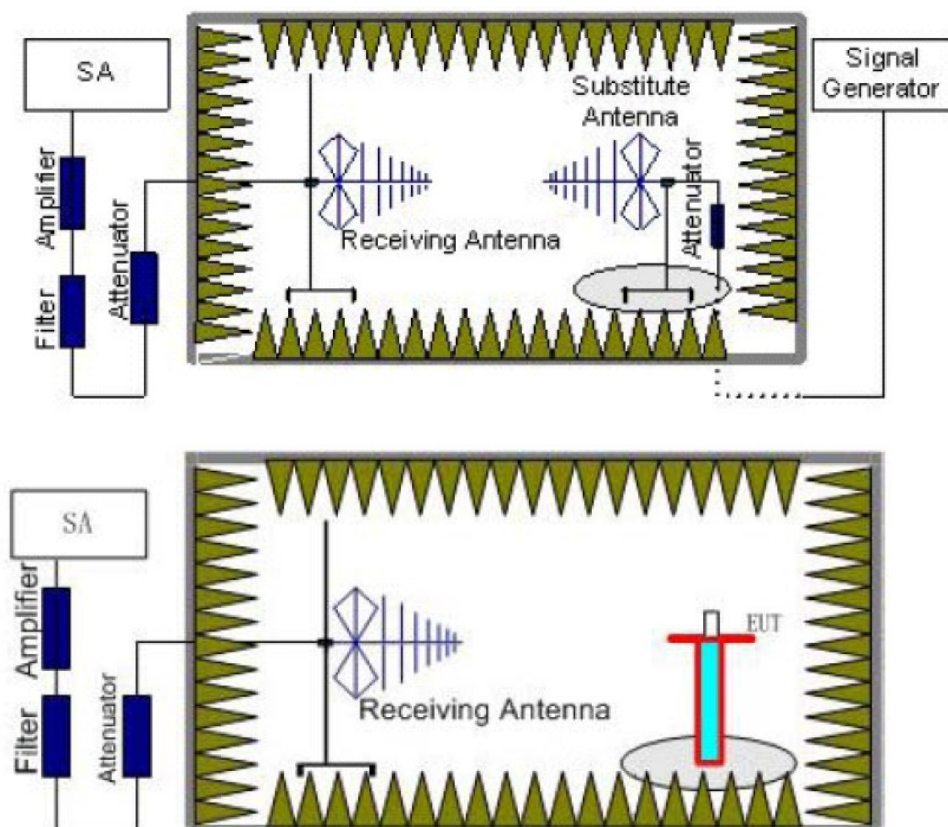

TEST PROCEDURE

1. EUT was placed on a 1.50 meter high non-conductive stand at a 3 meter test distance from the receive antenna. A receiving antenna was placed on the antenna mast 3 meters from the EUT for emission measurements. The height of receiving antenna is 1.50 m. Detected emissions were maximized at each frequency by rotating the EUT through 360° and adjusting the receiving antenna polarization. The radiated emission measurements of all transmit frequencies in six channels were measured with peak detector.

2. A log-periodic antenna or double-ridged waveguide horn antenna shall be substituted in place of the EUT. The log-periodic antenna will be driven by a signal generator and the level will be adjusted till the same power value on the spectrum analyzer or receiver. The level of the spurious emissions can be calculated through the level of the signal generator, cable loss, the gain of the substitution antenna and the reading of the spectrum analyzer or receiver.
3. The EUT is then put into continuously transmitting mode at its maximum power level during the test. Set Test Receiver or Spectrum RBW=1MHz, VBW=3MHz for above 1GHz and RBW=100KHz, VBW=300KHz for 30MHz to 1GHz, And the maximum value of the receiver should be recorded as (P_r).
4. The EUT shall be replaced by a substitution antenna. In the chamber, an substitution antenna for the frequency band of interest is placed at the reference point of the chamber. An RF Signal source for the frequency band of interest is connected to the substitution antenna with a cable that has been constructed to not interfere with the radiation pattern of the antenna. A power (P_{Mea}) is applied to the input of the substitution antenna, and adjust the level of the signal generator output until the value of the receiver reach the previously recorded (P_r). The power of signal source (P_{Mea}) is recorded. The test should be performed by rotating the test item and adjusting the receiving antenna polarization.
5. A amplifier should be connected to the Signal Source output port. And the cable should be connect between the Amplifier and the Substitution Antenna. The cable loss (P_{cl}), the Substitution Antenna Gain (G_a) and the Amplifier Gain (P_{Ag}) should be recorded after test.
The measurement results are obtained as described below:
Power(EIRP)= $P_{Mea} - P_{Ag} - P_{cl} - G_a$
We used SMF100A microwave signal generator which signal level can up to 33dBm, so we not used power Amplifier for substitution test; The measurement results are amend as described below:
Power(EIRP)= $P_{Mea} - P_{cl} - G_a$
6. This value is EIRP since the measurement is calibrated using an antenna of known gain (2.15 dBi) and known input power.
7. ERP can be calculated from EIRP by subtracting the gain of the dipole, ERP = EIRP-2.15dBi.

LIMIT

Modulation Type: 4FSK/GMSK

FCC Part 22.359, 74.462, 80.211 and 90.210 and RSS Gen, RSS 119 Issue 11 (12.5 kHz Bandwidth only):
On any frequency removed from the center of the authorized bandwidth by a displacement frequency (f_d in kHz) of more than 12.5 kHz at least:

Low: $50 + 10 \log(P_{watts}) = 50 + 10 \log(P)$

High: $50 + 10 \log(P_{watts}) = 50 + 10 \log(P)$

Note: In general, the worse case attenuation requirement shown above was applied.

Calculation: Limit (dBm) = EL-50-10log10 (TP)

Notes:

EL is the emission level of the Output Power expressed in dBm, In this application, the EL is 43.98 dBm.

*Limit (dBm) = 10log(1000*p)-50-10log10 (9) = -20 dBm*

Note: 1. In general, the worse case attenuation requirement shown above was applied.

2. The measurement frequency range from 30 MHz to 5 GHz.

3. *** means that the emission level is too low to be measured or at least 20 dB down than the limit.

TEST RESULTS

4.8. Modulation Characteristics

TEST APPLICABLE

According to CFR47 section 2.1047(a), for Voice Modulation Communication Equipment, the frequency response of the audio modulation circuit over a range of 100 to 5000Hz shall be measured.

TEST PROCEDURE

Modulation Limit

- 1 Configure the EUT as shown in figure 1, adjust the audio input for 60% of rated system deviation at 1 KHz using this level as a reference (0dB) and vary the input level from -20 to +20dB. Record the frequency deviation obtained as a function of the input level.
- 2 Repeat step 1 with input frequency changing to 300, 1004, 1500 and 2500Hz in sequence.

Audio Frequency Response

- 1 Configure the EUT as shown in figure 1.
- 2 Adjust the audio input for 20% of rated system deviation at 1 KHz using this level as a reference (0dB).
- 3 Vary the Audio frequency from 100 Hz to 3 KHz and record the frequency deviation.
- 4 Audio Frequency Response = $20\log_{10}$ (Deviation of test frequency/Deviation of 1 KHz reference).

TEST CONFIGURATION

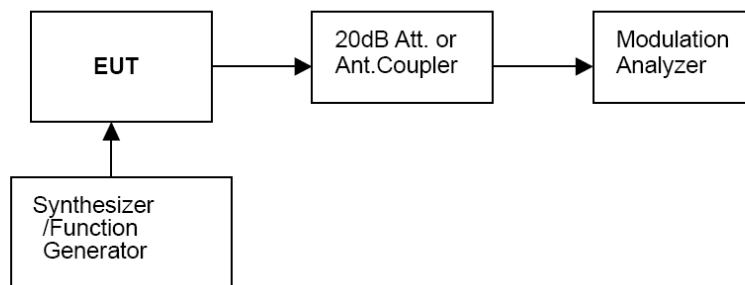

TEST RESULTS

Modulation type: 4FSK

Channel bandwidth: 12.5 kHz

It is not applicable for devices which operate with the digitized voice/data modulation type.

Audio Frequency Response:

Rule Part No.: Part 2.1407(a) (b)

Method of Measurement:

The audio frequency response was measured in accordance with TIA/EIA Specification 603 with no exception. A curve or equivalent data showing the frequency response of the audio modulating circuit over a range of 300-3000Hz shall be submitted and Audio Post Limiter Low Pass Filter Response from 3.0 KHz to 50KHz. However, the audio frequency response should test from 100Hz to 5.0 KHz according to FCC Part 90.

Modulation type: 4FSK/GMSK

Channel bandwidth: 12.5 kHz

It is not applicable for devices which operate with the digitized voice/data modulation type.

4.9. Receiver Radiated Spurious Emission

TEST APPLICABLE

The field strength is calculated by adding the Antenna Factor and Cable Factor and subtracting the Amplifier Gain and Duty Cycle Correction Factor (if any) from the measured reading. The basic equation with a sample calculation is as follows:

$$FS = RA + AF + CL - AG$$

Where FS = Field Strength	CL = Cable Attenuation Factor (Cable Loss)
RA = Reading Amplitude	AG = Amplifier Gain
AF = Antenna Factor	

TEST CONFIGURATION

(A) Radiated Emission Test Set-Up, Frequency below 1000MHz

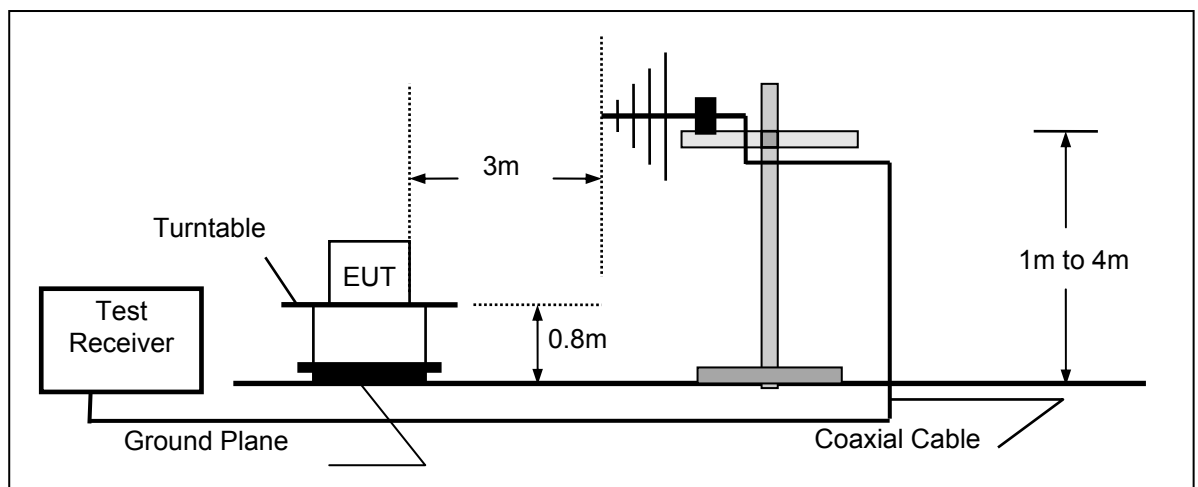

(B) Radiated Emission Test Set-Up, Frequency above 1000MHz

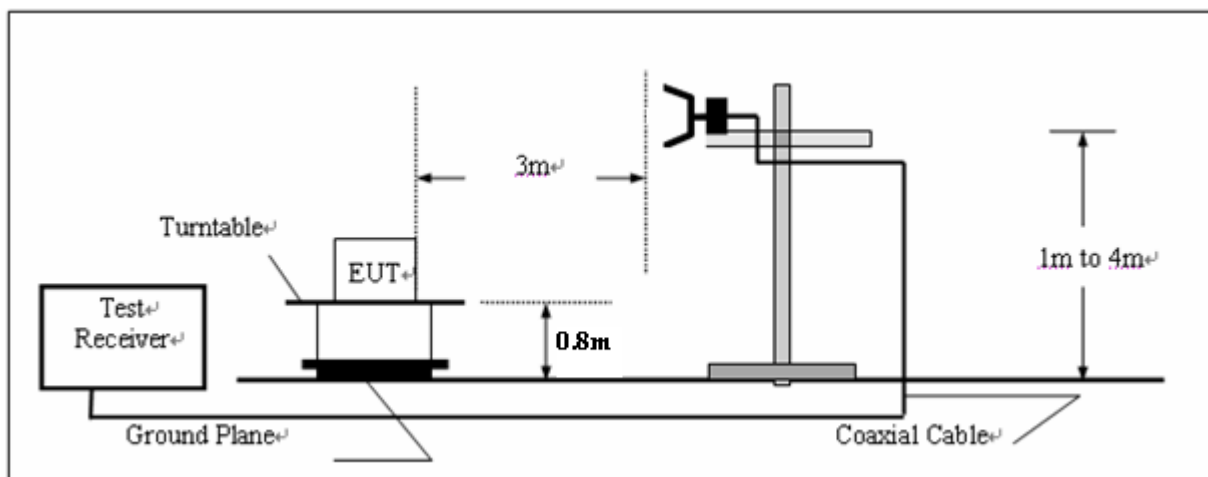

TEST PROCEDURE

- 1 The EUT was placed on a turn table which is 0.8m above ground plane.
- 2 Maximum procedure was performed by raising the receiving antenna from 1m to 4m and rotating the turn table from 0° to 360° to acquire the highest emissions from EUT
- 3 And also, each emission was to be maximized by changing the polarization of receiving antenna both horizontal and vertical.
- 4 Repeat above procedures until all frequency measurements have been completed.

RECEIVER RADIATED SPOUIOUS LIMIT

For unintentional device, according to § 15.109(a) and RSS-Gen, except for Class A digital devices, the field strength of radiated emissions from unintentional radiators at a distance of 3 meters shall not exceed the following values:

Frequency (MHz)	Distance (Meters)	Radiated (dB μ V/m)	Radiated (μ V/m)
30-88	3	40.0	100
88-216	3	43.5	150
216-960	3	46.0	200
Above 960	3	54.0	500

For intentional device, according to § 15.209(a), the general requirement of field strength of radiated emissions from intentional radiators at a distance of 3 meters shall not exceed the above table.

TEST RESULTS

The Eut only have tx, So this test item is not applicable for the EUT.

4.10. Receiver Conducted Spurious Emssion

TEST APPLICABLE

The same as Section 4.3

TEST PROCEDURE

The spectrum analyzer was connected to the RF output power of the EUT, the EUT was setup in receiving mode; The RBW of the spectrum analyzer was set to 100 kHz and the VBW set to 300 KHz below the test frequency 1GHz. While the RBW of the spectrum analyzer was set to the 1MHz and VBW set to the 3MHz from 1GHz to the 10th harmonic.

TEST CONFIGURATION

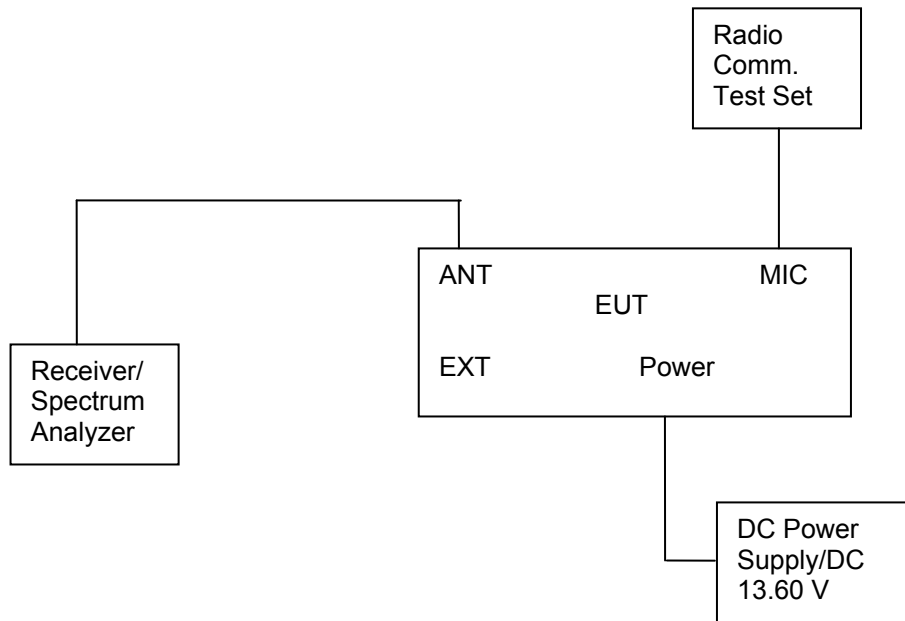

LIMIT

The power at the antenna terminal shall not exceed 2.0 nanowatts (-57dBm).

TEST RESULTS

The Eut only have tx, So this test item is not applicable for the EUT.

.....End of Report.....