

### INSTALLATION INSTRUCTIONS

#### IMPORTANT SAFEGUARDS

When using electrical equipment, basic safety precautions should always be followed including the following:

#### READ AND FOLLOW ALL SAFETY INSTRUCTIONS

1. Before installing turn off the power at the circuit breaker.
2. Any changes or modifications to these devices not explicitly approved by manufacturer could void your authority to operate this equipment.

#### SAVE THESE INSTRUCTIONS FOR FUTURE REFERENCE

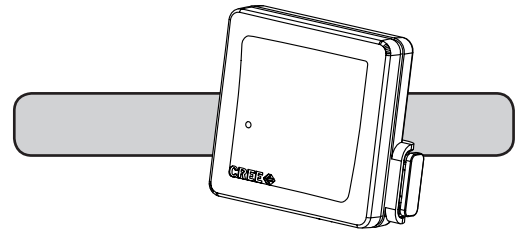

#### TO INSTALL:

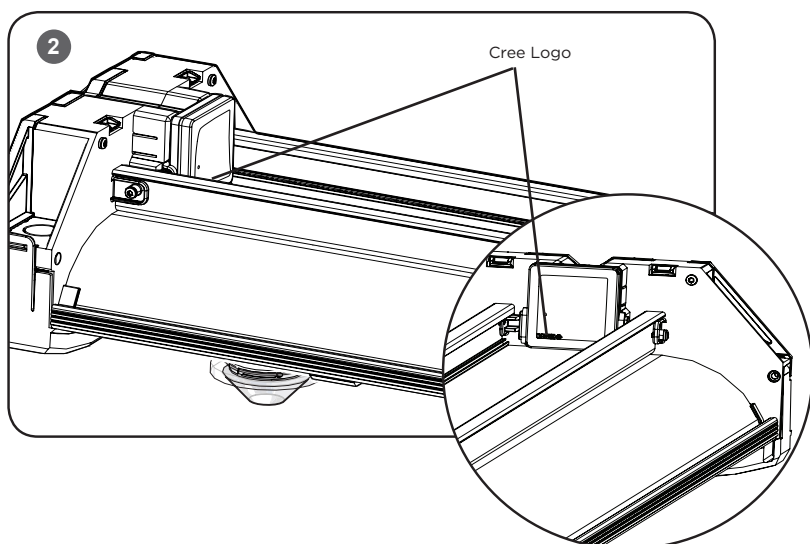
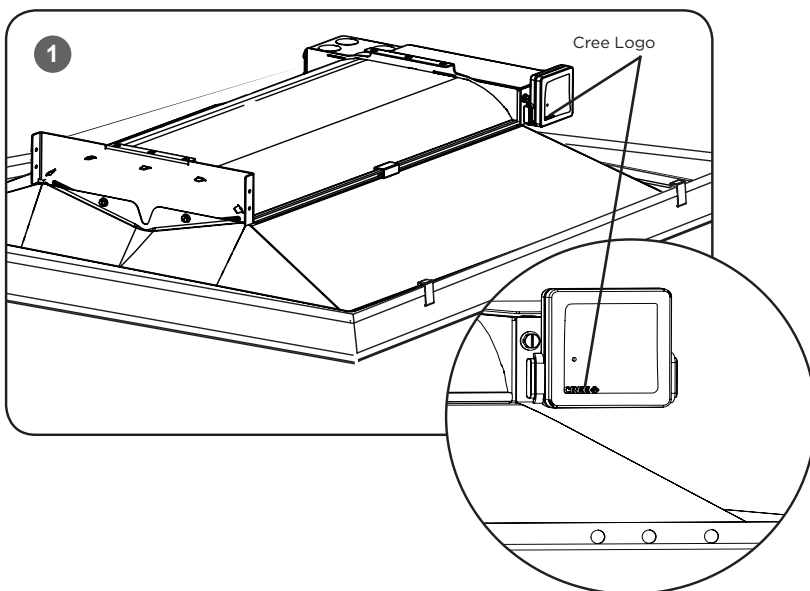

#### STEP 1:

Turn power off and remove old control module from luminaire by pressing the clips located on both sides of control module inward and pull control module out from luminaire.

**NOTE:** For location of the control module reference **Figure 1** for CR luminaires and **Figure 2** for CS luminaires.

#### STEP 2:

Orient the new control module so that the Cree logo is in the lower left corner. Attach the new control module to the CR or CS luminaire by pressing in on the clips located on the sides of the control module and inserting it into the designated connector.

#### STEP 3:

Turn power on. The new control module is correctly installed if the Blue LED displays a 2 blink sequence.

**NOTE:** If the blue LED does not respond with the two-blink sequence, please follow the RESET instructions to return the control module to factory defaults.

#### STEP 4:

On the Configuration Tool, select "Replace Devices" from the "Advanced" menu and follow the on-screen directions.. This will remove old device(s) from the network and add the new device(s).

#### RESET

**NOTE:** The Blue LED is located behind the Cree logo on the control module. The Cree logo will illuminate blue when the Blue LED is active.

#### STEP 1:

Actuate RESET button through the test hole. Push and hold (approximately 10 sec), LED on control module will blink fast.

#### STEP 2:

Release for 1 sec.

#### STEP 3:

Press/Hold RESET button for 0.5 sec. Light will go to full bright and the Blue LED on the control module should be in a 2 blink sequence.

## FCC NOTICE

---

To comply with the FCC RF exposure compliance requirements, this device and its antenna must not be co-located or operating to conjunction with any other antenna or transmitter. This equipment should be installed and operated with minimum distance 5cm between the radiator & your body. No other antenna is authorized for use with this product.

### FCC COMPLIANCE STATEMENT

CAUTION: Changes or modifications not expressly approved could void your authority to use this equipment.

This device complies with Part 15 of the FCC Rules. Operation to the following two conditions: (1) This device may not cause harmful interference, and (2) this device must accept any interference received, including interference that may cause undesired operation

This device has been tested and found to comply with the limits for a Class A digital device, pursuant to Part 15 of the FCC Rules. These limits are designed to provide reasonable protection against harmful interference when the device is operated in a commercial environment. This device generates, uses, and can radiate radio frequency energy and, if not installed and used in accordance with the instruction manual, may cause harmful interference to radio communications. Operation of this device in a residential area is likely to cause harmful interference in which case the user will be required to correct the interference at his own expense.

The LED in the front of this device operates within Risk Group 1 levels per IEC 62471.

### INDUSTRY CANADA STATEMENT

This device complies with Industry Canada licence-exempt RSS standard(s). Operation is subject to the following two conditions: (1) this device may not cause interference, and (2) this device must accept any interference, including interference that may cause undesired operation of the device. In addition, this device complies with ICES-003 of the Industry Canada (IC) Regulations.

Le présent appareil est conforme aux CNR d'Industrie Canada applicables aux appareils radio exempts de licence. L'exploitation est autorisée aux deux conditions suivantes : (1) l'appareil ne doit pas produire de brouillage, et (2) l'utilisateur de l'appareil doit accepter tout brouillage radioélectrique subi, même si le brouillage est susceptible d'en compromettre le fonctionnement.