



**FCC PART 15 SUBPART C  
ISED RSS-247 ISSUE 2  
CERTIFICATION TEST REPORT**

*For*

**Wireless Scene Controller**

**MODEL NUMBER: CSC-SC-A-5B-UNVN-WH, CSC-SC-A-5B-UNV-WH**

**FCC ID: 2ACQ6-CSC  
IC: 11481A-CSC**

**REPORT NUMBER: 4789677056.2.2**

**ISSUE DATE: 02 Feb. 2021**

*Prepared for*

**IDEAL INDUSTRIES LIGHTING LLC, DBA CREE LIGHTING  
4401 Silicon Drive Durham, NC 27703 USA**

*Prepared by*

**UL Verification Services (Guangzhou) Co., Ltd, Song Shan Lake Branch  
Room 101, Building 10, Innovation Technology Park, Song Shan Lake Hi tech  
Development Zone, Dongguan, 523808, China  
Tel: +86 769 33817100  
Fax: +86 769 33244054  
Website: [www.ul.com](http://www.ul.com)**



Revision History

<u>Rev.</u>	<u>Issue Date</u>	<u>Revisions</u>	<u>Revised By</u>
--	02/02/2021	Initial Issue	--



Summary of Test Results			
Clause	Test Items	FCC/IC Rules	Test Results
1	6dB Bandwidth and 99% Occupied Bandwidth	FCC Part 15.247 (a) (2) RSS-247 Clause 5.2 (a) RSS-Gen Clause 6.7	Pass
2	Peak Conducted Output Power	FCC Part 15.247 (b) (3) RSS-247 Clause 5.4 (d)	Pass
3	Power Spectral Density	FCC Part 15.247 (e) RSS-247 Clause 5.2 (b)	Pass
4	Conducted Band edge And Spurious emission	FCC Part 15.247 (d) RSS-247 Clause 5.5	Pass
5	Radiated Bandedge and Spurious Emission	FCC Part 15.247 (d) FCC Part 15.209 FCC Part 15.205 RSS-247 Clause 5.5 RSS-GEN Clause 8.9	Pass
6	Conducted Emission Test For AC Power Port	FCC Part 15.207 RSS-GEN Clause 8.8	Pass
7	Antenna Requirement	FCC Part 15.203 RSS-GEN Clause 6.8	Pass



## TABLE OF CONTENTS

<b>1. ATTESTATION OF TEST RESULTS</b> .....	<b>5</b>
<b>2. TEST METHODOLOGY</b> .....	<b>6</b>
<b>3. FACILITIES AND ACCREDITATION</b> .....	<b>6</b>
<b>4. CALIBRATION AND UNCERTAINTY</b> .....	<b>7</b>
4.1. <i>MEASURING INSTRUMENT CALIBRATION</i> .....	7
4.2. <i>MEASUREMENT UNCERTAINTY</i> .....	7
<b>5. EQUIPMENT UNDER TEST</b> .....	<b>8</b>
5.1. <i>DESCRIPTION OF EUT</i> .....	8
5.2. <i>MAXIMUM OUTPUT POWER</i> .....	8
5.3. <i>CHANNEL LIST</i> .....	8
5.4. <i>TEST CHANNEL CONFIGURATION</i> .....	8
5.5. <i>THE WORSE CASE POWER SETTING PARAMETER</i> .....	8
5.6. <i>DESCRIPTION OF AVAILABLE ANTENNAS</i> .....	9
5.7. <i>WORST-CASE CONFIGURATIONS</i> .....	9
5.8. <i>DESCRIPTION OF TEST SETUP</i> .....	10
<b>6. MEASURING INSTRUMENT AND SOFTWARE USED</b> .....	<b>11</b>
<b>7. MEASUREMENT METHODS</b> .....	<b>12</b>
<b>8. ANTENNA PORT TEST RESULTS</b> .....	<b>13</b>
8.1. <i>ON TIME AND DUTY CYCLE</i> .....	13
8.2. <i>6 dB BANDWIDTH &amp; 99% BANDWIDTH</i> .....	15
8.3. <i>PEAK CONDUCTED OUTPUT POWER</i> .....	20
8.4. <i>POWER SPECTRAL DENSITY</i> .....	21
8.5. <i>CONDUCTED BANDEDGE AND SPURIOUS EMISSIONS</i> .....	24
<b>9. RADIATED TEST RESULTS</b> .....	<b>29</b>
9.1. <i>LIMITS AND PROCEDURE</i> .....	29
9.2. <i>RESTRICTED BANDEDGE</i> .....	35
9.3. <i>SPURIOUS EMISSIONS 30MHz-1GHz</i> .....	39
9.4. <i>SPURIOUS EMISSIONS Above 1 GHz</i> .....	42
9.5. <i>SPURIOUS EMISSIONS BELOW 30M</i> .....	46
<b>10. AC POWER LINE CONDUCTED EMISSIONS</b> .....	<b>47</b>
<b>11. ANTENNA REQUIREMENTS</b> .....	<b>52</b>



# 1. ATTESTATION OF TEST RESULTS

## Applicant Information

Company Name: IDEAL INDUSTRIES LIGHTING LLC, DBA CREE LIGHTING  
Address: 4401 Silicon Drive Durham, NC 27703 USA

## Manufacturer Information

Company Name: Katerra Lighting (Shanghai) Co., Ltd  
Address: 5F, Building 7, No. 333, Guiping Rd. Xuhui, Shanghai, China 200233

## Factory Information

Company Name: Same as the manufacturer  
Address: Same as the manufacturer

## EUT Description

EUT Name: Wireless Scene Controller  
Brand Name: **CREE**  **LIGHTING**  
Model: CSC-SC-A-5B-UNVN-WH, CSC-SC-A-5B-UNV-WH  
Sample Status: Normal  
Sample Received Date: 15 Dec. 2020  
Date of Tested: 16 Dec. 2020 ~ 20 Dec. 2020

APPLICABLE STANDARDS	
STANDARD	TEST RESULTS
FCC Part 15 Subpart C	PASS
ISED RSS-247 Issue 2	PASS
ISED RSS-GEN Issue 5	PASS

Prepared By:

Chris Chen  
Engineer Project Associate  
Approved By:

Stephen Guo  
Laboratory Manager

Checked By:

Shawn Wen  
Laboratory Leader



## 2. TEST METHODOLOGY

The tests documented in this report were performed in accordance with 558074 D01 DTS Meas Guidance v05, 414788 D01 Radiated Test Site v01, FCC CFR 47 Part 2, FCC CFR 47 Part 15 ANSI C63.10-2013, ISED RSS-247 Issue 2 and ISED RSS-GEN Issue 5.

## 3. FACILITIES AND ACCREDITATION

Accreditation Certificate	<p><b>A2LA (Certificate No.: 4338.01)</b> Shenzhen STS Test Services Co., Ltd. has been assessed and proved to be in compliance with A2LA.</p> <p><b>CNAS (Registration No.: L7649)</b> Shenzhen STS Test Services Co., Ltd. has been assessed and proved to be in compliance with CNAS.</p> <p><b>FCC (FCC Designation No.: 625569)</b> Shenzhen STS Test Services Co., Ltd. has been recognized to perform compliance testing on equipment subject to the Commission's Declaration of Conformity (DoC) and Certification rules</p> <p><b>IC(Company No.: 12108A)</b> Shenzhen STS Test Services Co., Ltd. has been registered and fully described in a report filed with Industry Canada. The Company Number is 12108A.</p>
---------------------------	---

Note 1: All tests measurement facilities use to collect the measurement data are located at A 1/F, Building B, Zhuoke Science Park, No.190 Chongqing Road, HepingShequ, Fuyong Sub-District, Bao'an District, Shenzhen, Guang Dong, China

Note 2: The test anechoic chamber in SHENZHEN STS TEST SERVICES CO., LTD had been calibrated and compared to the open field sites and the test anechoic chamber is shown to be equivalent to or worst case from the open field site.



## 4. CALIBRATION AND UNCERTAINTY

### 4.1. MEASURING INSTRUMENT CALIBRATION

The measuring equipment utilized to perform the tests documented in this report has been calibrated in accordance with the manufacturer's recommendations, and is traceable to recognized national standards.

### 4.2. MEASUREMENT UNCERTAINTY

The reported uncertainty of measurement  $y \pm U$ , where expanded uncertainty  $U$  is based on a standard uncertainty multiplied by a coverage factor of  $k=2$ , providing a level of confidence of approximately **95 %**.

No.	Item	Uncertainty
1	RF output power, conducted	$\pm 0.71\text{dB}$
2	Unwanted Emissions, conducted	$\pm 0.63\text{dB}$
3	All emissions, radiated 30-1000MHz	$\pm 4.39\text{dB}$
4	All emissions, radiated 1GHz-6GHz	$\pm 5.10\text{dB}$
5	All emissions, radiated >6G	$\pm 5.48\text{dB}$
6	Conducted Emission (9KHz-150KHz)	$\pm 2.79\text{dB}$
7	Conducted Emission (150KHz-30MHz)	$\pm 2.80\text{dB}$



## 5. EQUIPMENT UNDER TEST

### 5.1. DESCRIPTION OF EUT

EUT Name	Wireless Scene Controller	
EUT Description	The EUT is a Zigbee Wireless Scene Controller	
Model	CSC-SC-A-5B-UNVN-WH, CSC-SC-A-5B-UNV-WH	
Product Description (Zigbee)	Operation Frequency	2405 MHz ~ 2480 MHz
	Modulation Type	OQPSK
Series model	CSC-SC-A-5S-UNVN-WH, CSC-SC-A-5C-UNVN-WH, CSC-SC-A-5S-UNV-WH, CSC-SC-A-5C-UNV-WH	
Model Difference	The electrical circuit design, layout, components used, and internal wiring are identical, there're 2 pcs power supply board used (same electrical circuit design, and layout difference). The difference of each number of buttons and appearance.	
Power Parameter	AC 120V 60Hz	
Hardware Version	N/A	
Software Version	N/A	

### 5.2. MAXIMUM OUTPUT POWER

Frequency Range (MHz)	Number of Transmit Chains (NTX)	Bluetooth Mode	Channel Number	Max PK Conducted Power (dBm)	Max EIRP (dBm)
2405-2480	1	OQPSK	1-16[16]	1.06	0.56

### 5.3. CHANNEL LIST

Channel	Frequency (MHz)	Channel	Frequency (MHz)	Channel	Frequency (MHz)	Channel	Frequency (MHz)
1	2405	5	2425	9	2445	13	2465
2	2410	6	2430	10	2450	14	2470
3	2415	7	2435	11	2455	15	2475
4	2420	8	2440	12	2460	16	2480

### 5.4. TEST CHANNEL CONFIGURATION

Test Mode	Test Channel	Frequency
OQPSK	CH 1, CH 8, CH 16	2405MHz, 2440MHz, 2480MHz

### 5.5. THE WORSE CASE POWER SETTING PARAMETER

The Worst Case Power Setting Parameter under 2400 ~ 2483.5MHz Band				
Modulation Type	Transmit Antenna Number	Test Channel		
		CH 1	CH 8	CH 16
OQPSK	1	Default	Default	Default





### 5.6. DESCRIPTION OF AVAILABLE ANTENNAS

Ant.	Frequency (MHz)	Antenna Type	Antenna Gain (dBi)
1	2405-2480	PCB Antenna	-0.5

Test Mode	Transmit and Receive Mode	Description
OQPSK	<input checked="" type="checkbox"/> 1TX, 1RX	Chain 1 can be used as transmitting/receiving antenna.

### 5.7. WORST-CASE CONFIGURATIONS

Mode	Modulation Technology	Modulation Type	Data Rate (Mbps)
Zigbee	DTS	OQPSK	0.25

## 5.8. DESCRIPTION OF TEST SETUP

### SUPPORT EQUIPMENT

Item	Equipment	Brand Name	Model Name	P/N
1	N/A	N/A	N/A	N/A

### I/O CABLES

Cable No	Port	Connector Type	Cable Type	Cable Length(cm)	Remarks
1	N/A	N/A	AC cable	80cm	N/A

### TEST SETUP

The EUT can work in an engineer mode with a software through a Laptop.

### SETUP DIAGRAM FOR TESTS

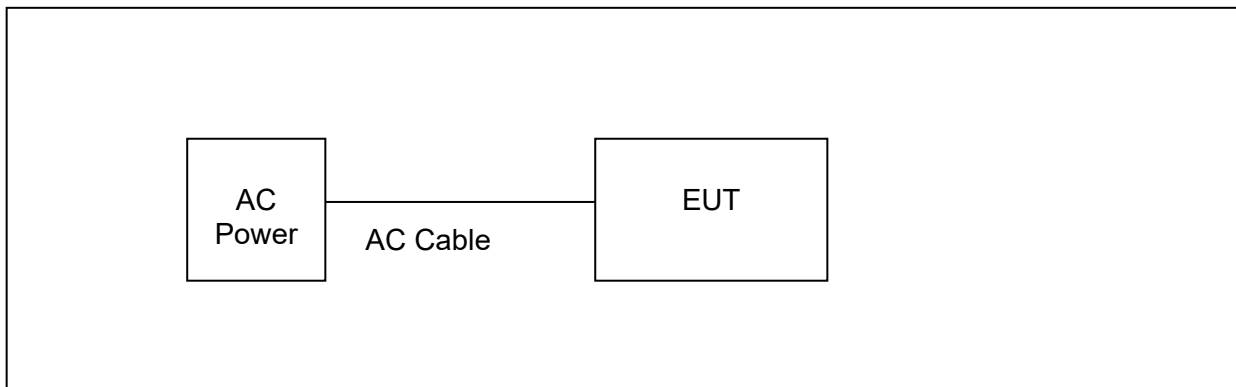



## 6. MEASURING INSTRUMENT AND SOFTWARE USED

Conducted Emissions						
Used	Equipment	Manufacturer	Model No.	Serial No.	Last Cal.	Next Cal.
<input checked="" type="checkbox"/>	Test Receiver	R&S	ESCI	101427	2020.10.12	2021.10.11
<input checked="" type="checkbox"/>	LISN	R&S	ENV216	101242	2020.10.12	2021.10.11
<input checked="" type="checkbox"/>	LISN	EMCO	3810/2NM	23625	2020.10.12	2021.10.11
<input checked="" type="checkbox"/>	Temperature & Humidity	HH660	Mieo	N/A	2020.10.13	2021.10.12
Radiated Emissions						
Used	Equipment	Manufacturer	Model No.	Serial No.	Last Cal.	Next Cal.
<input checked="" type="checkbox"/>	Test Receiver	R&S	ESCI	101427	2020.10.12	2021.10.11
<input checked="" type="checkbox"/>	Signal Analyzer	R&S	FSV 40-N	101823	2020.10.10	2021.10.09
<input checked="" type="checkbox"/>	Active loop Antenna	ZHINAN	ZN30900C	16035	2019.07.11	2021.07.10
<input checked="" type="checkbox"/>	Bilog Antenna	TESEQ	CBL6111D	34678	2020.10.12	2022.10.11
<input checked="" type="checkbox"/>	Horn Antenna	SCHWARZBEC K	BBHA 9120D	02014	2019.10.15	2021.10.14
<input checked="" type="checkbox"/>	SHF-EHF Horn Antenna (18G-40GHz)	A-INFO	LB-180400-KF	J21102065 7	2020.10.12	2022.10.11
<input checked="" type="checkbox"/>	Pre-Amplifier(0.1M-3GHz)	EM	EM330	060665	2020.10.12	2021.10.11
<input checked="" type="checkbox"/>	Pre-Amplifier (1G-18GHz)	SKET	LNPA-01018G-45	SK201808 0901	2020.10.12	2021.10.11
<input checked="" type="checkbox"/>	Pre-Amplifier (18G-40GHz)	SKET	LNPA-1840-50	SK201810 1801	2020.10.10	2021.10.09
<input checked="" type="checkbox"/>	Temperature & Humidity	HH660	Mieo	N/A	2020.10.13	2021.10.12
<input checked="" type="checkbox"/>	Turn table	EM	SC100_1	60531	N/A	N/A
<input checked="" type="checkbox"/>	Antenna mast	EM	SC100	N/A	N/A	N/A
RF Connected Test						
Used	Equipment	Manufacturer	Model No.	Serial No.	Last Cal.	Next Cal.
<input checked="" type="checkbox"/>	Power Sensor	Keysight	U2021XA	MY55520005	2020.10.10	2021.10.09
<input checked="" type="checkbox"/>				MY55520006	2020.10.10	2021.10.09
<input checked="" type="checkbox"/>				MY56120038	2020.10.10	2021.10.09
<input checked="" type="checkbox"/>				MY56280002	2020.10.10	2021.10.09
<input checked="" type="checkbox"/>	Signal Analyzer	Agilent	N9020A	MY51110105	2020.03.05	2021.03.04
<input checked="" type="checkbox"/>	Temperature & Humidity	HH660	Mieo	N/A	2020.10.13	2021.10.12



## 7. MEASUREMENT METHODS

No.	Test Item	KDB Name	Section
1	6dB Bandwidth and 99% Bandwidth	KDB 558074 D01 15.247 Meas Guidance v05r02	8.2
2	Peak Output Power	KDB 558074 D01 15.247 Meas Guidance v05r02	8.1.3
3	Power Spectral Density	KDB 558074 D01 15.247 Meas Guidance v05r02	8.4
4	Out-of-band emissions in non-restricted bands	KDB 558074 D01 15.247 Meas Guidance v05r02	8.5
5	Out-of-band emissions in restricted bands	KDB 558074 D01 15.247 Meas Guidance v05r02	8.6
6	Band-edge	KDB 558074 D01 15.247 Meas Guidance v05r02	8.7
7	Conducted Emission Test For AC Power Port	ANSI C63.10-2013	6.2

## 8. ANTENNA PORT TEST RESULTS

### 8.1. ON TIME AND DUTY CYCLE

#### LIMITS

None; for reporting purposes only

#### PROCEDURE

KDB 558074 Zero-Span Spectrum Analyzer Method

#### TEST SETUP

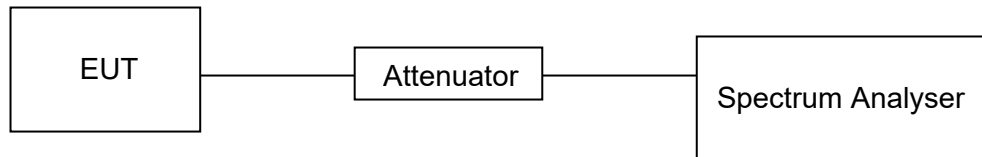

#### TEST ENVIRONMENT

Temperature	25°C	Relative Humidity	60%
Atmosphere Pressure	101kPa	Test Voltage	AC 120V 60Hz

#### RESULTS

Mode	On Time (msec)	Period (msec)	Duty Cycle x (Linear)	Duty Cycle (%)	Duty Cycle Correction Factor (db)	1/B Minimum VBW (KHz)
OQPSK	100	100	1	100	0	10

Note: Duty Cycle Correction Factor=10log(1/x).  
Where: x is Duty Cycle(Linear)  
Where: B is On Time

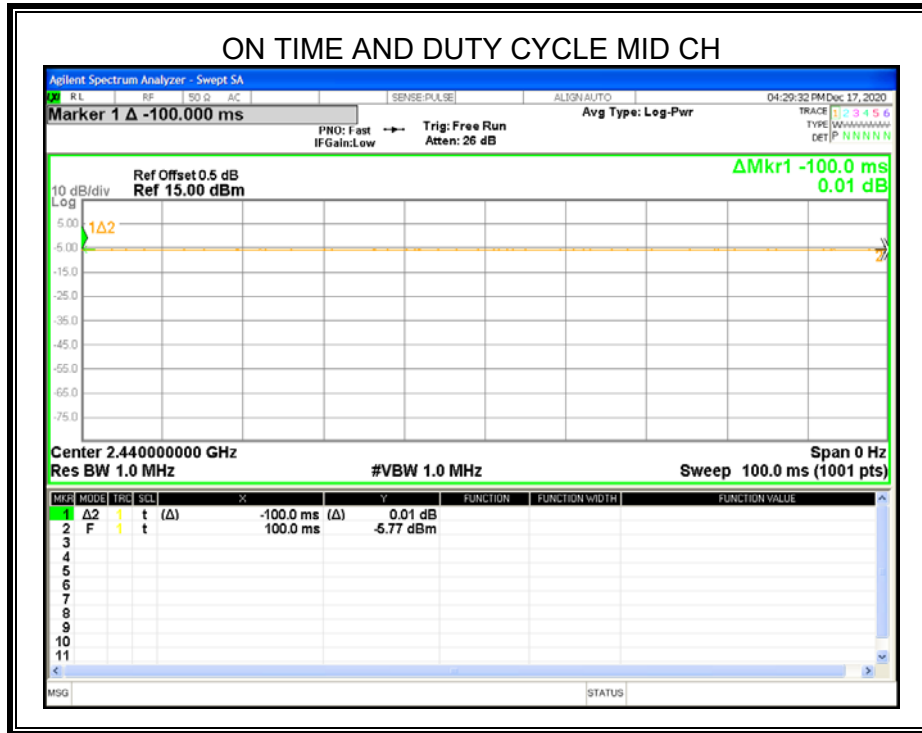

## 8.2. 6 dB BANDWIDTH & 99% BANDWIDTH

### LIMITS

FCC Part15 (15.247) Subpart C RSS-247 ISSUE 2			
Section	Test Item	Limit	Frequency Range (MHz)
FCC 15.247(a)(2) RSS-247 5.2 (a)	6dB Bandwidth	$\geq 500\text{KHz}$	2400-2483.5
RSS-Gen Clause 6.7	99% Bandwidth	For reporting purposes only.	2400-2483.5

### TEST PROCEDURE

Connect the UUT to the spectrum analyser and use the following settings:

Center Frequency	The centre frequency of the channel under test
Detector	Peak
RBW	For 6 dB Bandwidth : 100K For 99% Bandwidth : 1% to 5% of the occupied bandwidth
VBW	For 6dB Bandwidth : $\geq 3 \times \text{RBW}$ For 99% Bandwidth : approximately $3 \times \text{RBW}$
Trace	Max hold
Sweep	Auto couple

Allow the trace to stabilize and measure the maximum width of the emission that is constrained by the frequencies associated with the two outermost amplitude points (upper and lower frequencies) that are attenuated by 6 dB and 99% relative to the maximum level measured in the fundamental emission.

### TEST SETUP

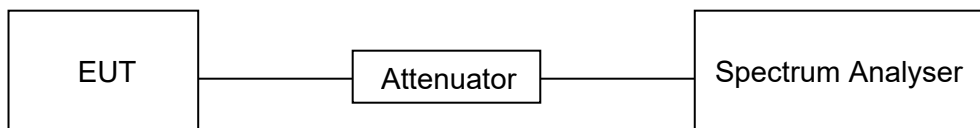



**TEST ENVIRONMENT**

Temperature	25°C	Relative Humidity	60%
Atmosphere Pressure	101kPa	Test Voltage	AC 120V 60Hz

**RESULTS**

Channel	Frequency (MHz)	6dB bandwidth (KHz)	99% bandwidth (MHz)	Limit (kHz)	Result
Low	2405	1568.000	2296.100	500	Pass
Middle	2440	1579.000	2296.600	500	Pass
High	2480	1600.000	2359.000	500	Pass

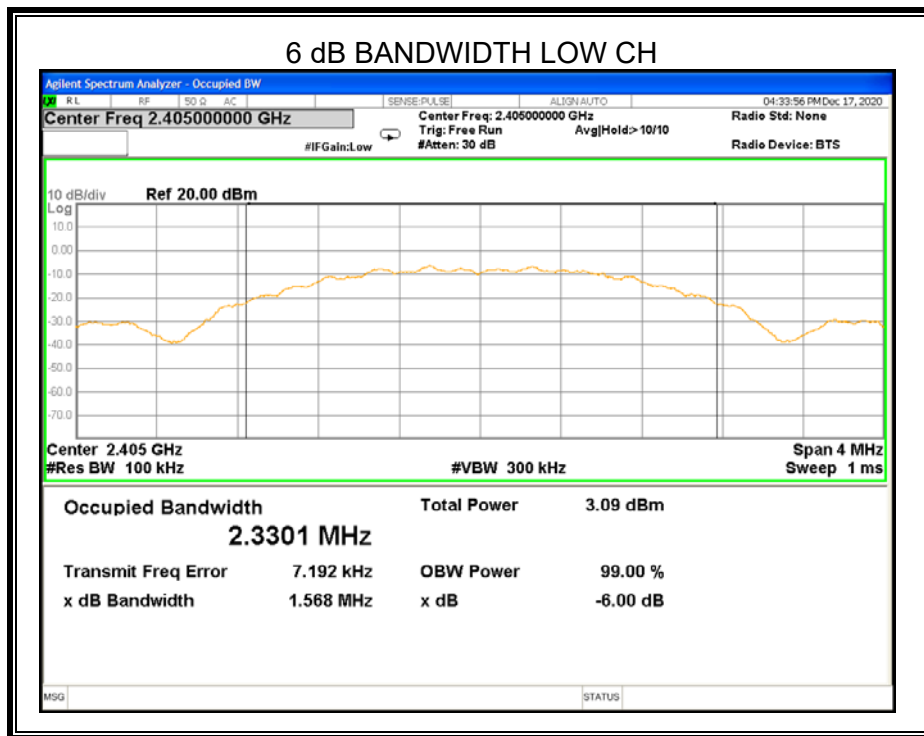



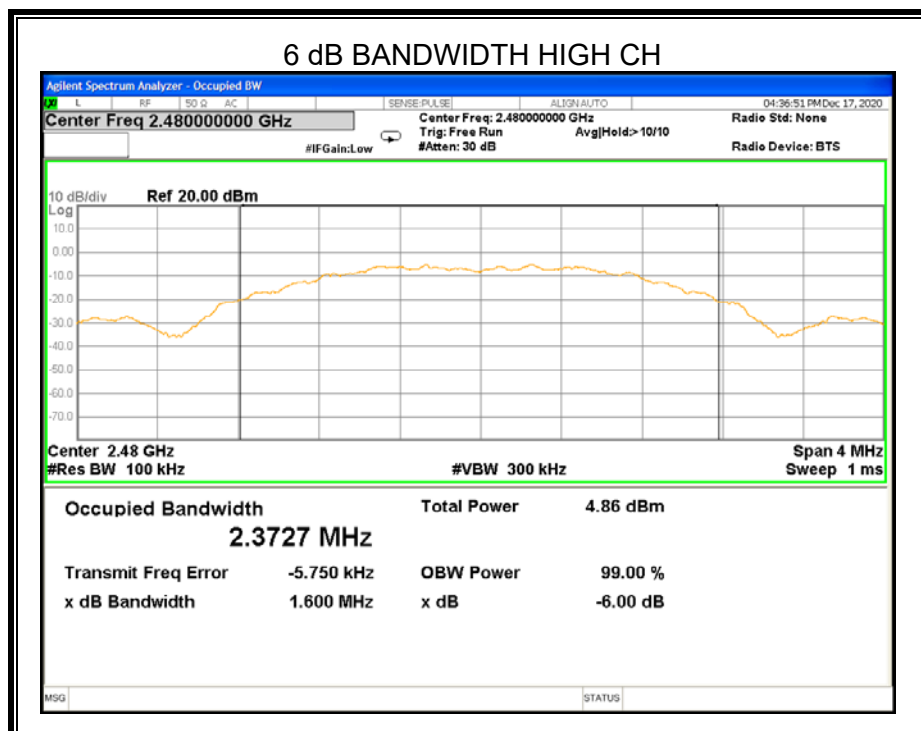
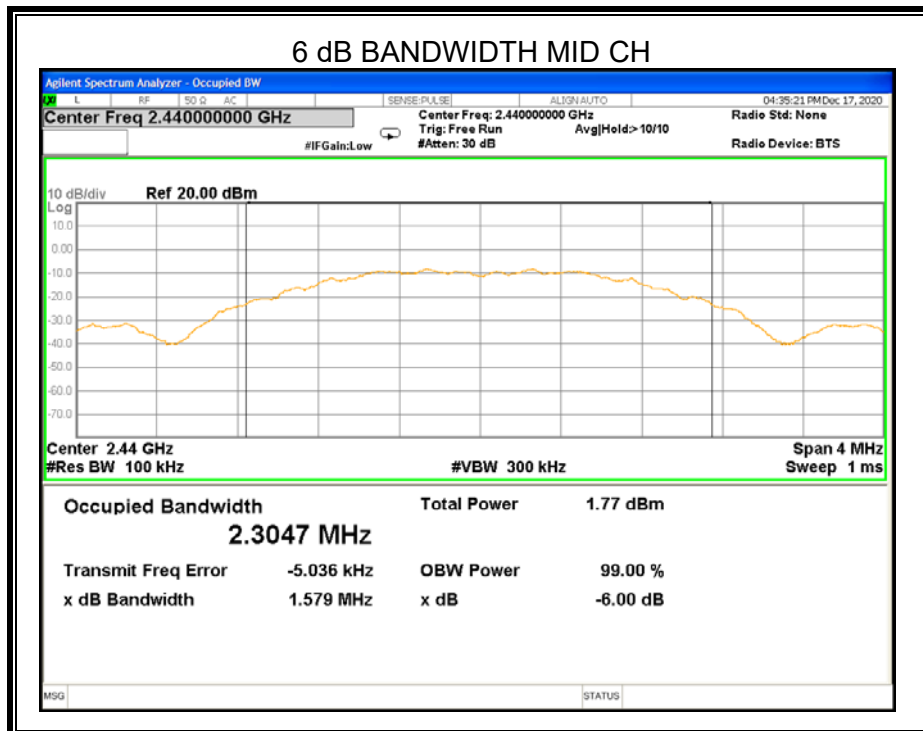

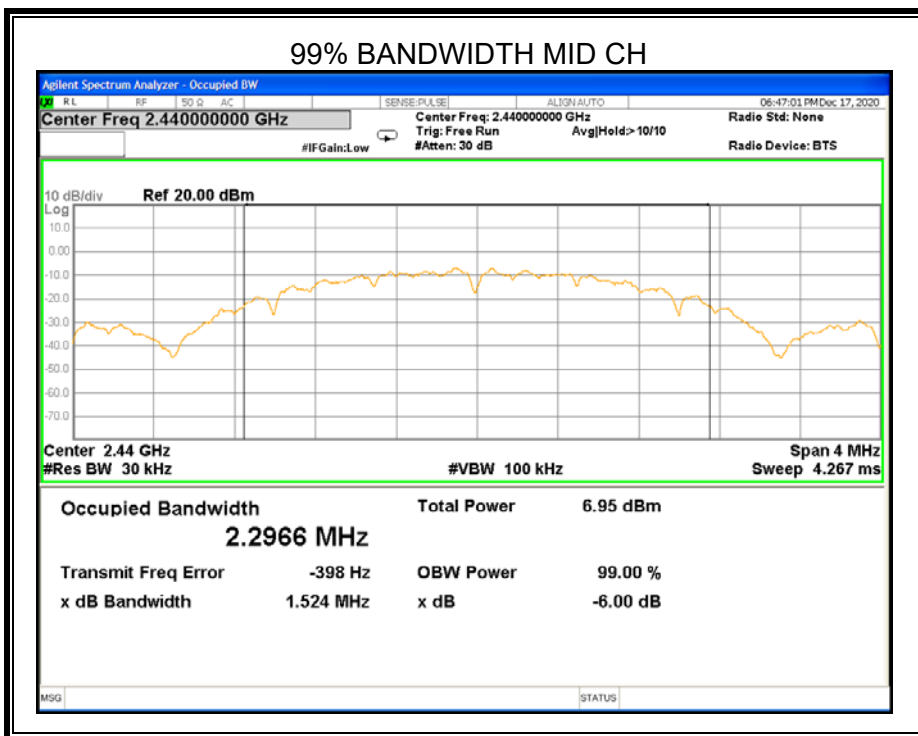
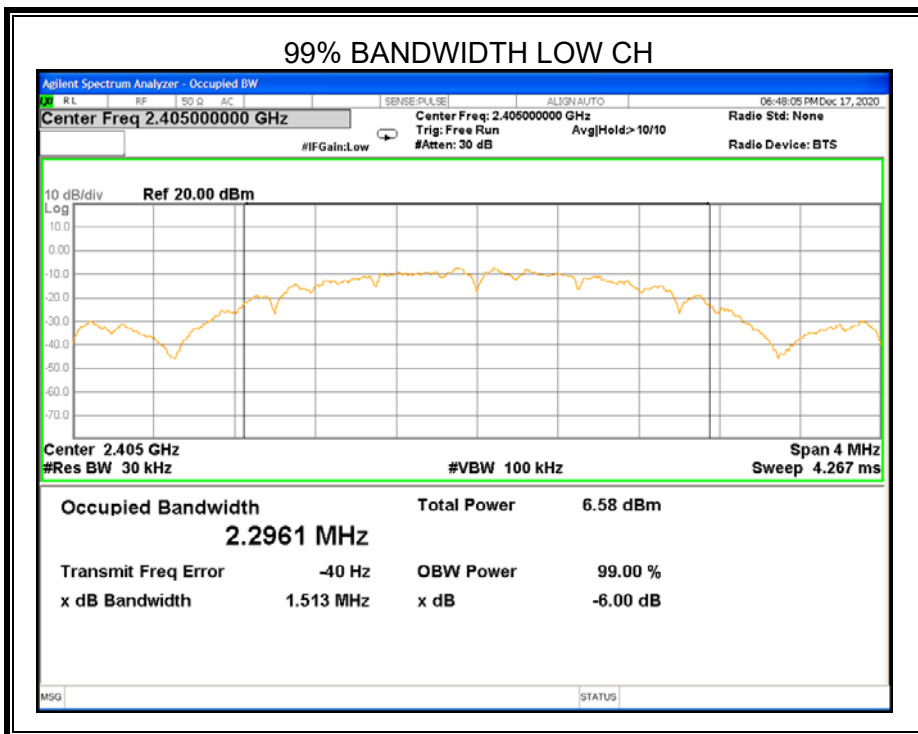

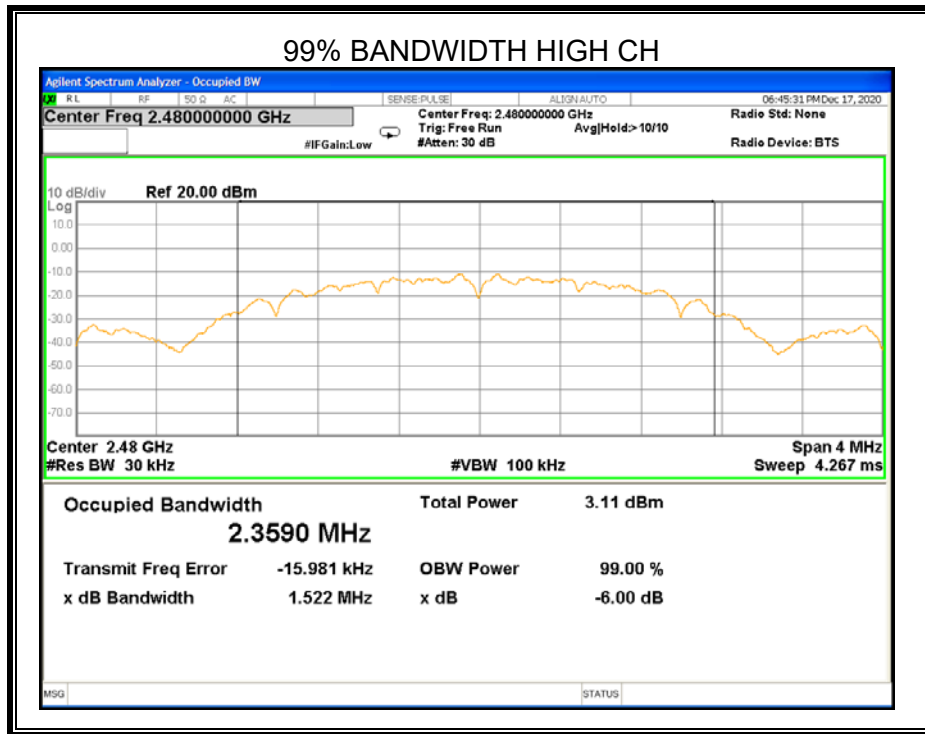

### 8.3. PEAK CONDUCTED OUTPUT POWER

#### LIMITS

FCC Part15 (15.247) , Subpart C RSS-247 ISSUE 2			
Section	Test Item	Limit	Frequency Range (MHz)
FCC 15.247(b)(3) RSS-247 5.4 (d)	Peak Output Power	1 watt or 30dBm	2400-2483.5

#### TEST PROCEDURE

Place the EUT on the table and set it in the transmitting mode.  
Remove the antenna from the EUT and then connect a low loss RF cable from the antenna port to the Power sensor.  
Measure peak power each channel.

#### TEST SETUP

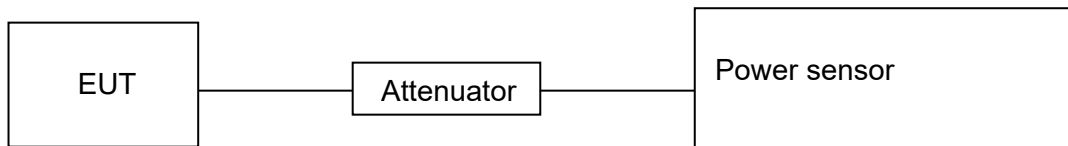

#### TEST ENVIRONMENT

Temperature	25°C	Relative Humidity	60%
Atmosphere Pressure	101kPa	Test Voltage	AC 120V 60Hz

#### RESULTS

Test Channel	Frequency	Maximum Conducted Output Power(PK)	LIMIT
	(MHz)	(dBm)	dBm
Low	2405	-0.53	30
Middle	2440	-1.62	30
High	2480	1.06	30

## 8.4. POWER SPECTRAL DENSITY

### LIMITS

FCC Part15 (15.247) , Subpart C RSS-247 ISSUE 2			
Section	Test Item	Limit	Frequency Range (MHz)
FCC §15.247 (e) RSS-247 5.2 (b)	Power Spectral Density	8 dBm in any 3 kHz band	2400-2483.5

### TEST PROCEDURE

Connect the UUT to the spectrum analyser and use the following settings:

Center Frequency	The centre frequency of the channel under test
Detector	Peak
RBW	$3 \text{ kHz} \leq \text{RBW} \leq 100\text{kHz}$
VBW	$\geq 3 \times \text{RBW}$
Span	1.5 x DTS bandwidth
Trace	Max hold
Sweep time	Auto couple.

Allow trace to fully stabilize and use the peak marker function to determine the maximum amplitude level within the RBW.

If measured value exceeds limit, reduce RBW (no less than 3 kHz) and repeat.

### TEST SETUP

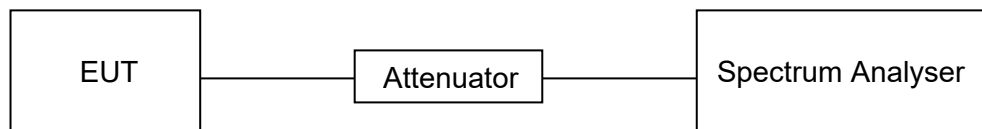



**TEST ENVIRONMENT**

Temperature	25°C	Relative Humidity	60%
Atmosphere Pressure	101kPa	Test Voltage	AC 120V 60Hz

**RESULTS**

Test Channel	Frequency	Power Spectral Density (dBm/3kHz)	Limit (dBm/3kHz)	Result
Low	2405 MHz	-19.429	8	PASS
Middle	2440 MHz	-20.351	8	PASS
High	2480 MHz	-17.128	8	PASS

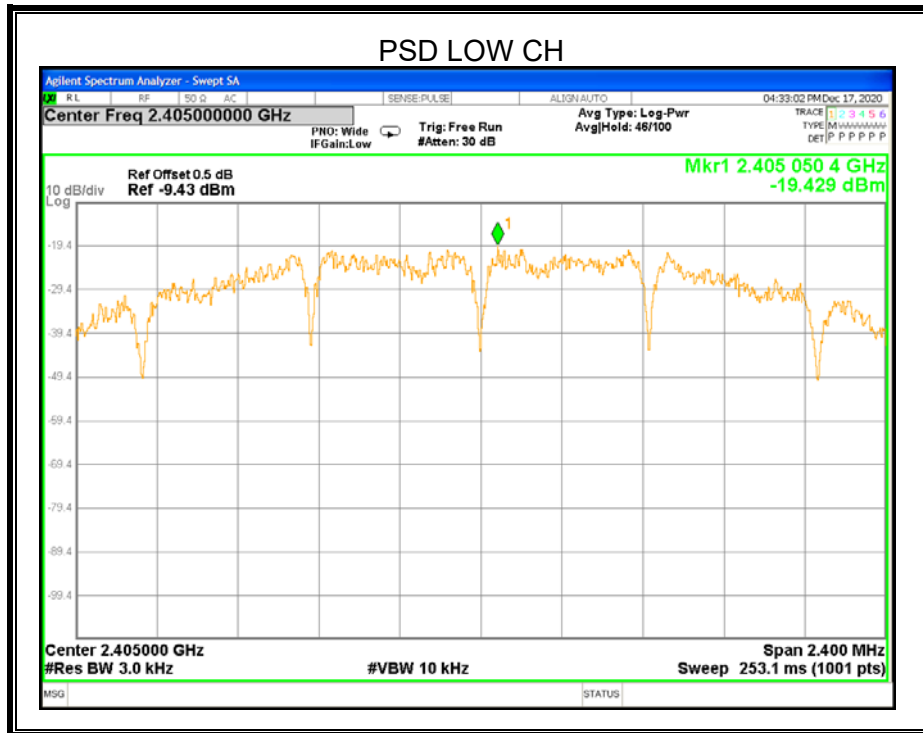

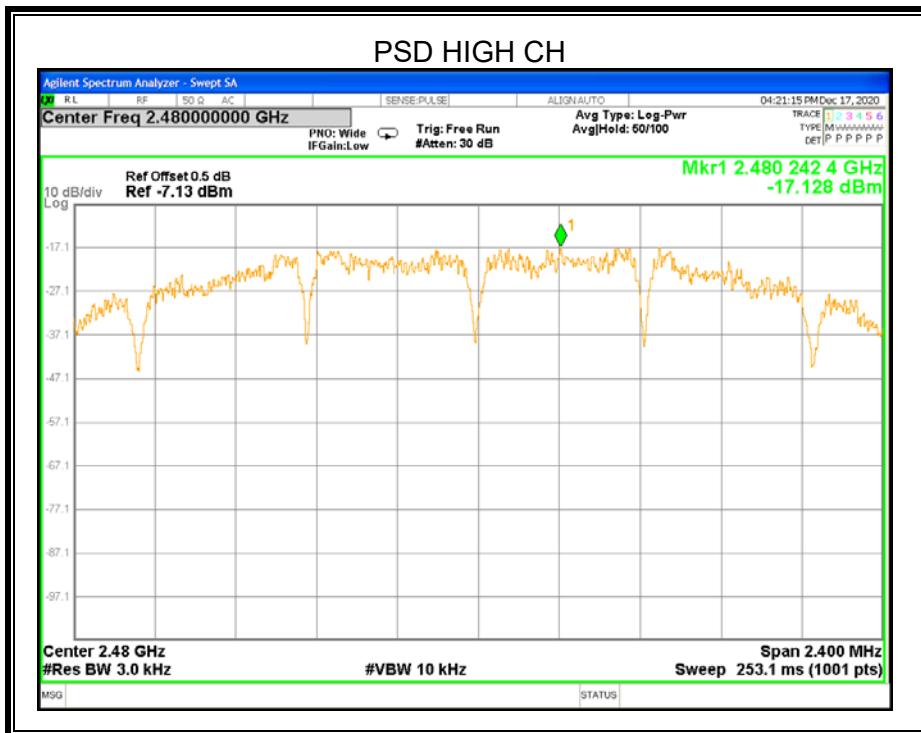
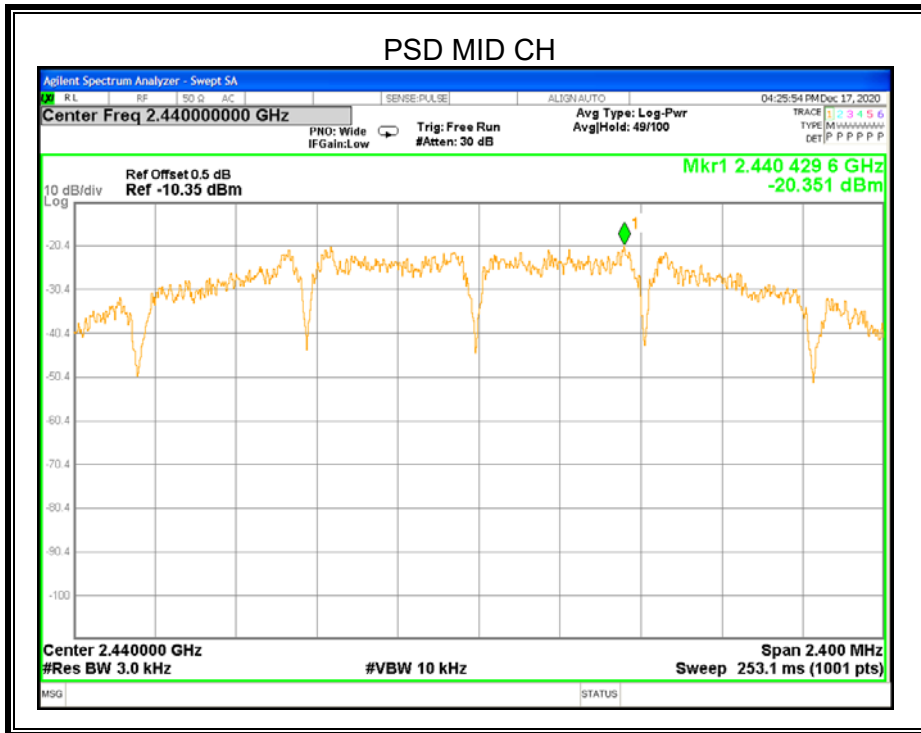

## 8.5. CONDUCTED BANDEGE AND SPURIOUS EMISSIONS

### LIMITS

FCC Part15 (15.247) , Subpart C RSS-247 ISSUE 2		
Section	Test Item	Limit
FCC §15.247 (d) RSS-247 5.5	Conducted Bandedge and Spurious Emissions	at least 20 dB below that in the 100 kHz bandwidth within the band that contains the highest level of the desired power

### TEST PROCEDURE

Connect the UUT to the spectrum analyser and use the following settings:

Center Frequency	The centre frequency of the channel under test
Detector	Peak
RBW	100K
VBW	$\geq 3 \times \text{RBW}$
Span	1.5 x DTS bandwidth
Trace	Max hold
Sweep time	Auto couple.

Use the peak marker function to determine the maximum PSD level.

Span	Set the center frequency and span to encompass frequency range to be measured
Detector	Peak
RBW	100K
VBW	$\geq 3 \times \text{RBW}$
measurement points	$\geq \text{span}/\text{RBW}$
Trace	Max hold
Sweep time	Auto couple.

Use the peak marker function to determine the maximum amplitude level.

### TEST SETUP

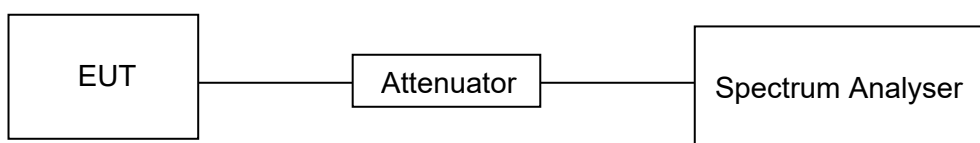





**TEST ENVIRONMENT**

Temperature	25°C	Relative Humidity	60%
Atmosphere Pressure	101kPa	Test Voltage	AC 120V 60Hz

**RESULTS**

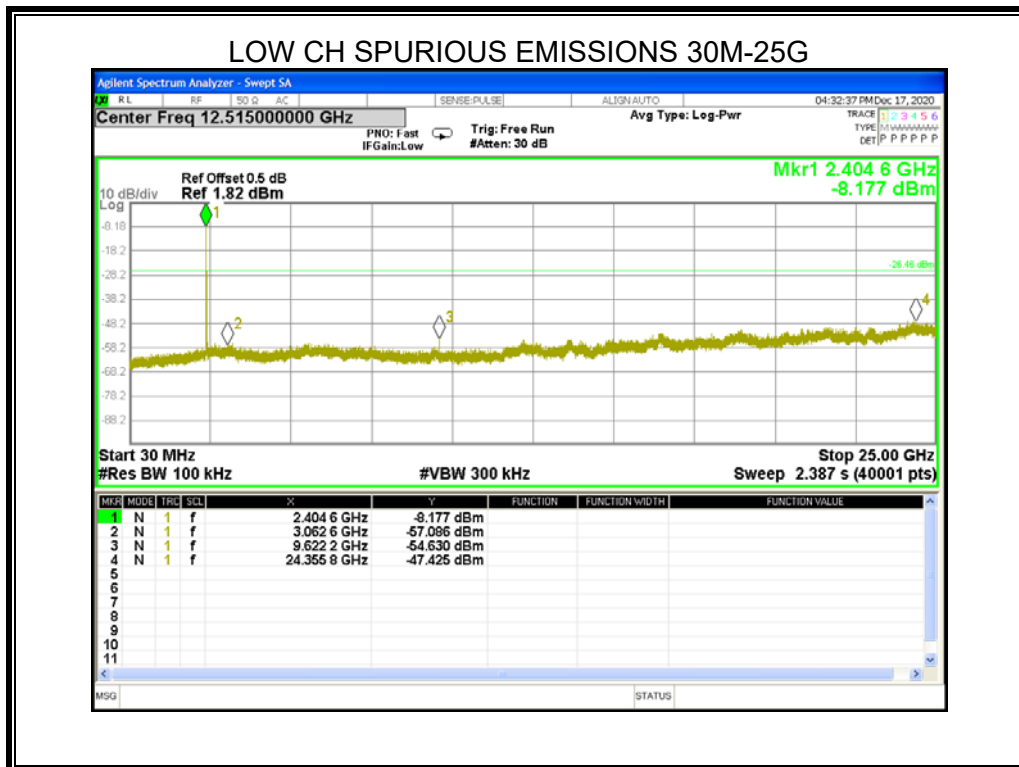

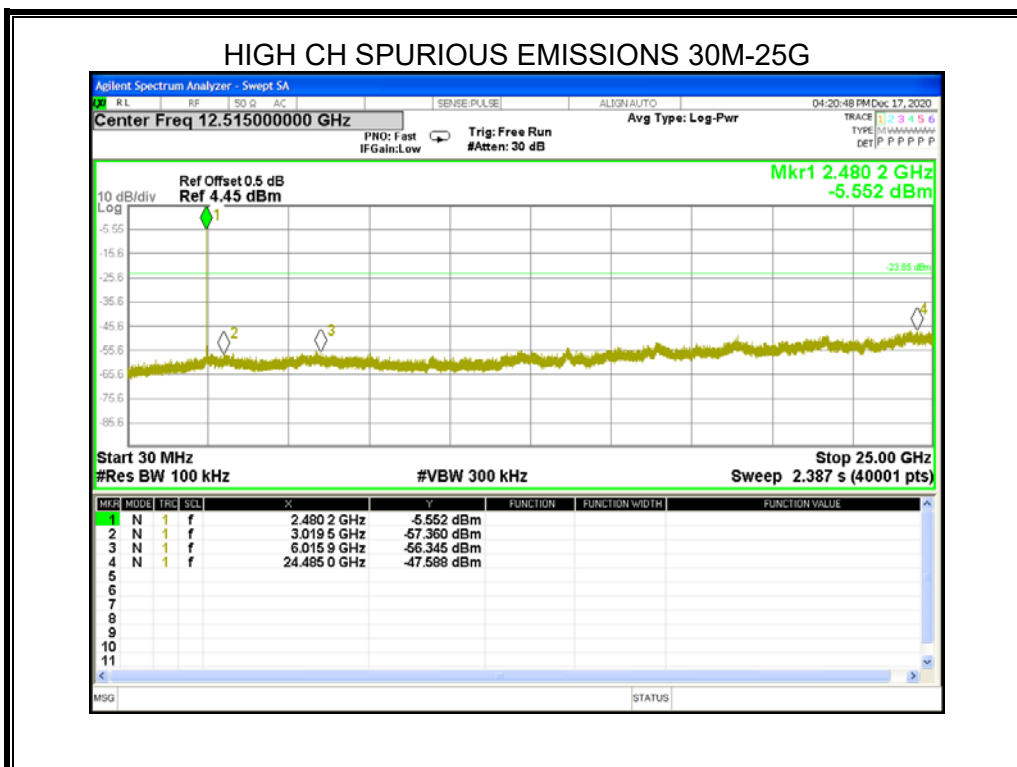
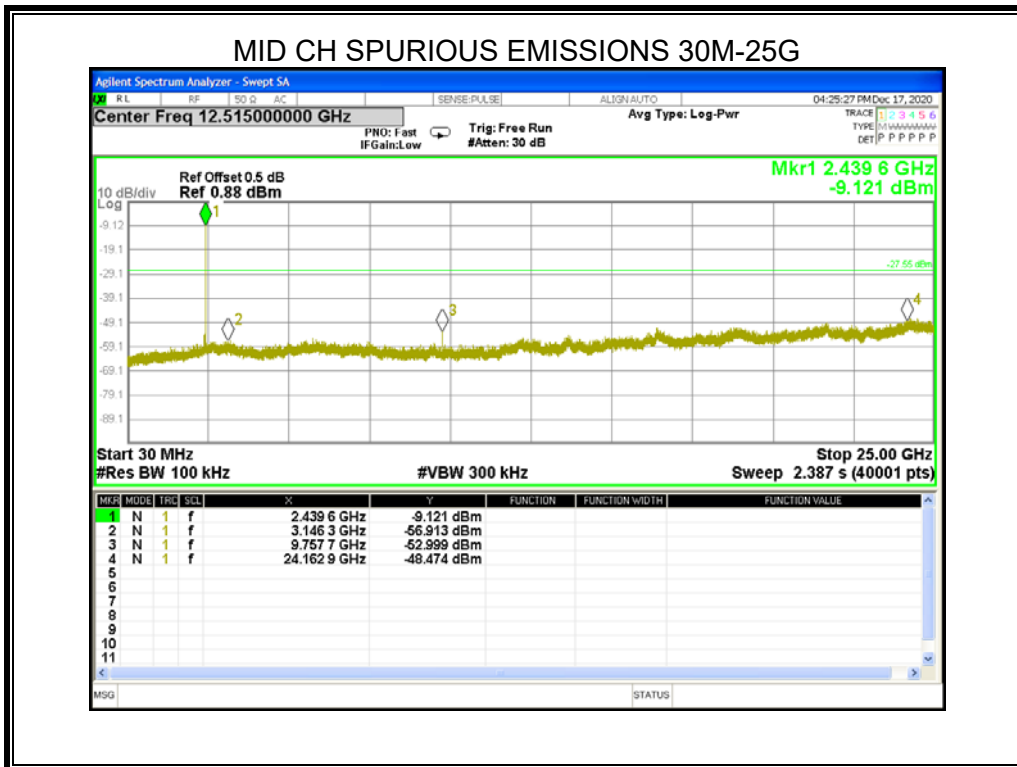

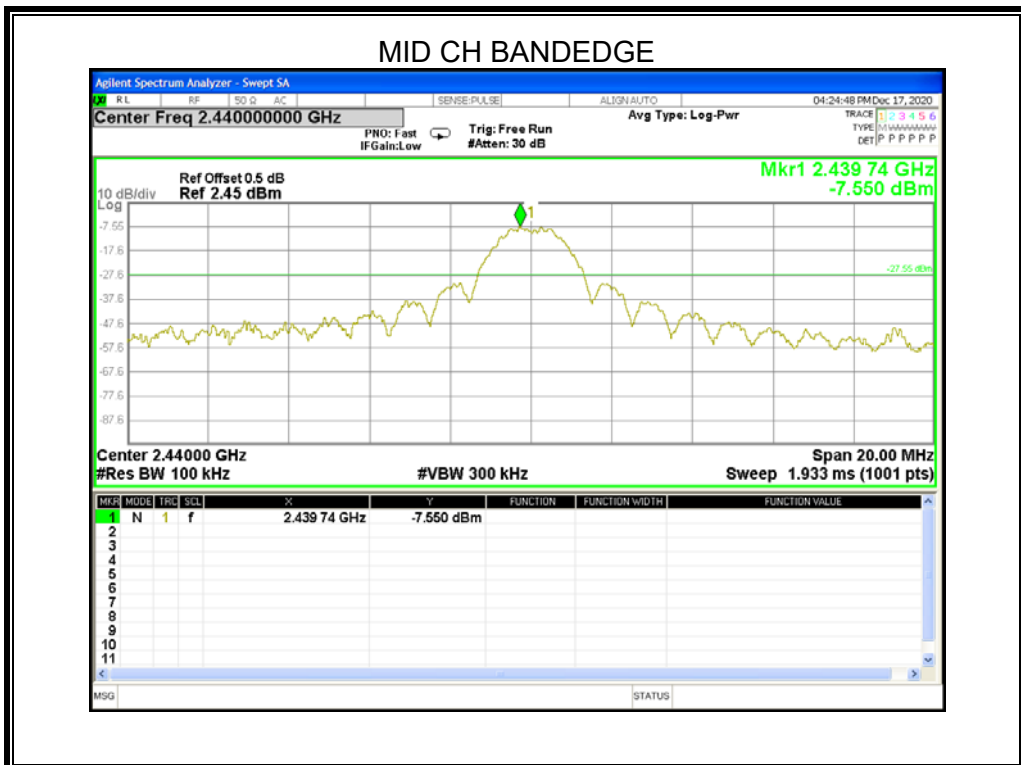
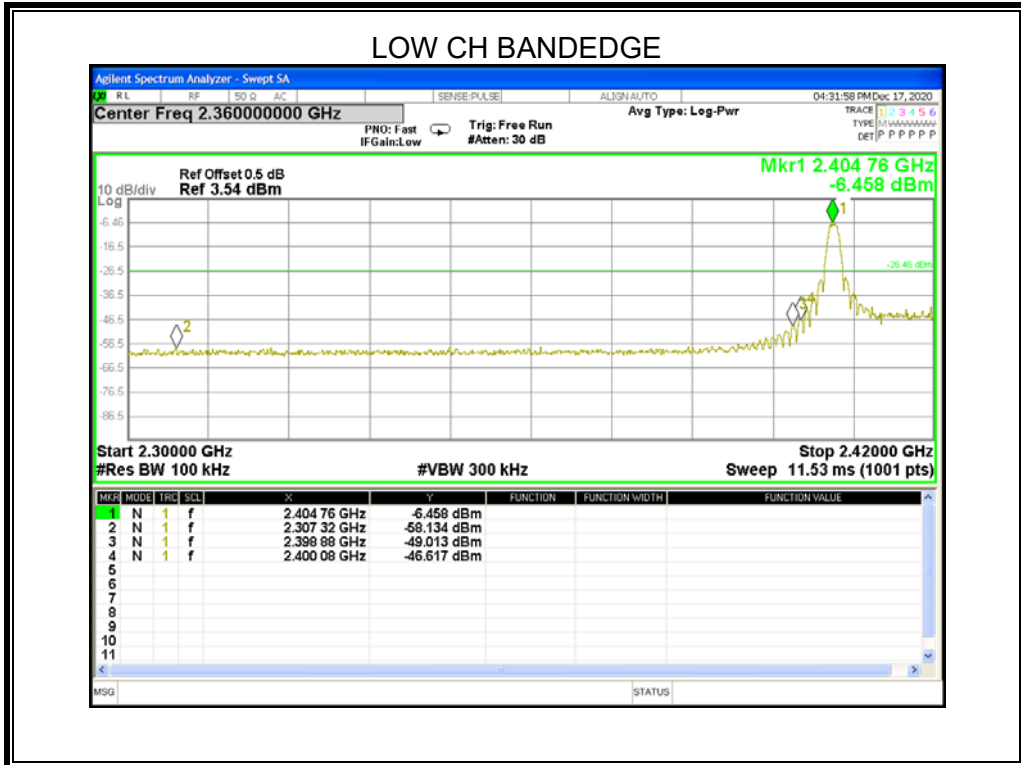

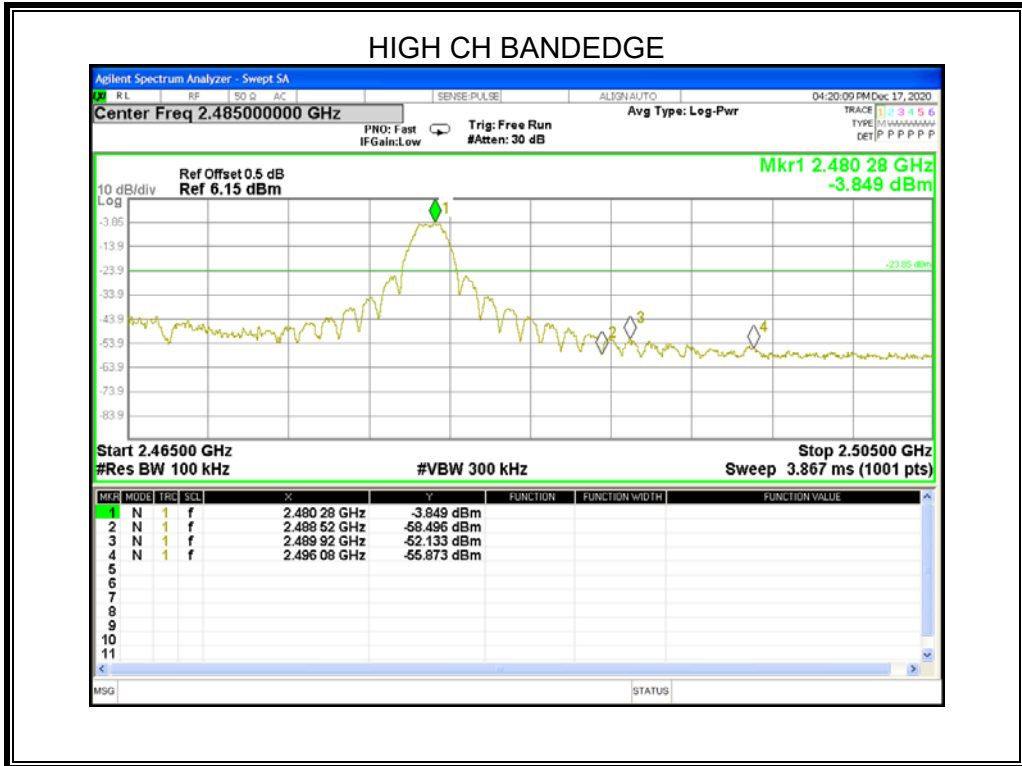

## 9. RADIATED TEST RESULTS

### 9.1. LIMITS AND PROCEDURE

Please refer to FCC §15.205 and §15.209

Please refer to RSS-GEN Clause 8.9 (Transmitter)

Radiation Disturbance Test Limit for FCC (Class B)(9KHz-1GHz)

Frequency (MHz)	Field Strength (microvolts/meter)	Measurement Distance (meters)
0.009~0.490	2400/F(KHz)	300
0.490~1.705	24000/F(KHz)	30
1.705~30.0	30	30
30~88	100	3
88~216	150	3
216~960	200	3
960~1000	500	3

Note: 1) At frequencies at or above 30 MHz, measurements may be performed at a distance other than what is specified provided: measurements are not made in the near field except where it can be shown that near field measurements are appropriate due to the characteristics of the device; and it can be demonstrated that the signal levels needed to be measured at the distance employed can be detected by the measurement equipment. Measurements shall not be performed at a distance greater than 30 meters unless it can be further demonstrated that measurements at a distance of 30 meters or less are impractical. When performing measurements at a distance other than that specified, the results shall be extrapolated to the specified distance using an extrapolation factor of 20 dB/decade (inverse linear-distance for field strength measurements; inverse-linear-distance-squared for power density measurements).

(2) At frequencies below 30 MHz, measurements may be performed at a distance closer than that specified in the regulations; however, an attempt should be made to avoid making measurements in the near field. Pending the development of an appropriate measurement procedure for measurements performed below 30 MHz, when performing measurements at a closer distance than specified, the results shall be extrapolated to the specified distance by either making measurements at a minimum of two distances on at least one radial to determine the proper extrapolation factor or by using the square of an inverse linear distance extrapolation factor (40 dB/decade). This paragraph (f) shall not apply to Access BPL devices operating below 30 MHz.



Radiation Disturbance Test Limit for FCC (Above 1G)

Frequency (MHz)	dB(uV/m) (at 3 meters)	
	Peak	Average
Above 1000	74	54

Restricted bands of operation

MHz	MHz	MHz	GHz
0.090-0.110	16.42-16.423	399.9-410	4.5-5.15
<sup>1</sup> 0.495-0.505	16.69475-16.69525	608-614	5.35-5.46
2.1735-2.1905	16.80425-16.80475	960-1240	7.25-7.75
4.125-4.128	25.5-25.67	1300-1427	8.025-8.5
4.17725-4.17775	37.5-38.25	1435-1626.5	9.0-9.2
4.20725-4.20775	73-74.6	1645.5-1646.5	9.3-9.5
6.215-6.218	74.8-75.2	1660-1710	10.6-12.7
6.26775-6.26825	108-121.94	1718.8-1722.2	13.25-13.4
6.31175-6.31225	123-138	2200-2300	14.47-14.5
8.291-8.294	149.9-150.05	2310-2390	15.35-16.2
8.362-8.366	156.52475-156.52525	2483.5-2500	17.7-21.4
8.37625-8.38675	156.7-156.9	2690-2900	22.01-23.12
8.41425-8.41475	162.0125-167.17	3260-3267	23.6-24.0
12.29-12.293	167.72-173.2	3332-3339	31.2-31.8
12.51975-12.52025	240-285	3345.8-3358	36.43-36.5
12.57675-12.57725	322-335.4	3600-4400	( <sup>2</sup> )
13.36-13.41			

Note: <sup>1</sup>Until February 1, 1999, this restricted band shall be 0.490-0.510 MHz.

<sup>2</sup>Above 38.6c

**TEST SETUP AND PROCEDURE**

Below 30MHz

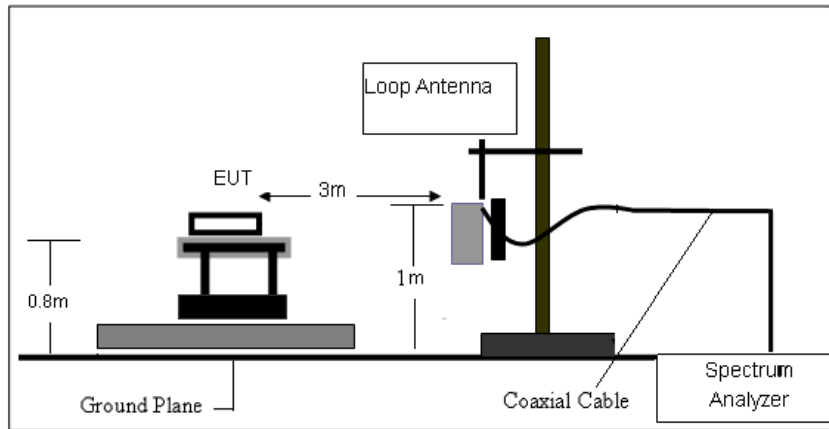

The setting of the spectrum analyser

RBW	200Hz (From 9kHz to 0.15MHz)/ 9KHz (From 0.15MHz to 30MHz)
VBW	200Hz (From 9kHz to 0.15MHz)/ 9KHz (From 0.15MHz to 30MHz)
Sweep	Auto
Detector	Peak/QP/ Average
Trace	Max hold

1. The testing follows the guidelines in ANSI C63.10-2013
2. The EUT was arranged to its worst case and then turntable (from 0 degree to 360 degrees) to find the maximum reading. A pre-amp and a high pass filter are used for the test in order to get better signal level. Both horizontal and vertical polarizations of the antenna are set to make the measurement.
3. The EUT was placed on a turntable with 0.8 meter above ground.
4. The EUT was set 3 meters from the interference receiving antenna, which was mounted on the top of a variable height antenna tower.
5. For measurement below 1GHz, the initial step in collecting conducted emission data is a spectrum analyzer peak detector mode pre-scanning the measurement frequency range. Significant peaks are then marked and then Quasi Peak detector mode re-measured. If the emission level of the EUT measured by the peak detector is 3 dB lower than the applicable limit, the peak emission level will be reported. Otherwise, the emission measurement will be repeated using the quasi-peak detector and reported.
6. For the actual test configuration, please refer to the related item in this test report (Photographs of the Test Configuration)

Note: Although these tests were performed other than open area test site, adequate comparison measurements were confirmed against 30m open area test site. Therefore sufficient tests were made to demonstrate that the alternative site produces results that correlate with the ones of tests made in an open field based on KDB 414788.

Below 1G

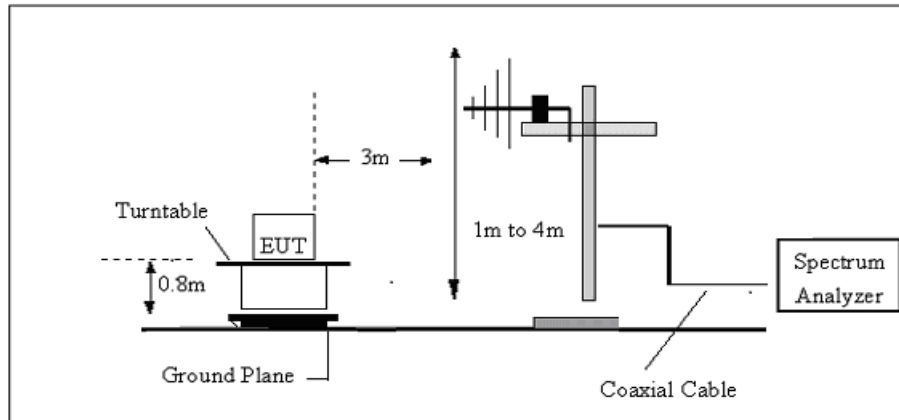

The setting of the spectrum analyser

RBW	120K
VBW	300K
Sweep	Auto
Detector	Peak/QP
Trace	Max hold

1. The testing follows the guidelines in ANSI C63.10-2013.
2. The EUT was arranged to its worst case and then tune the antenna tower (from 1 m to 4 m) and turntable (from 0 degree to 360 degrees) to find the maximum reading. A pre-amp and a high pass filter are used for the test in order to get better signal level. Both horizontal and vertical polarizations of the antenna are set to make the measurement.
3. The EUT was placed on a turntable with 0.8 meter above ground.
4. The EUT was set 3 meters from the interference receiving antenna, which was mounted on the top of a variable height antenna tower.
5. For measurement below 1GHz, the initial step in collecting conducted emission data is a spectrum analyzer peak detector mode pre-scanning the measurement frequency range. Significant peaks are then marked and then Quasi Peak detector mode re-measured. If the emission level of the EUT measured by the peak detector is 3 dB lower than the applicable limit, the peak emission level will be reported. Otherwise, the emission measurement will be repeated using the quasi-peak detector and reported.
6. For the actual test configuration, please refer to the related Item in this test report (Photographs of the Test Configuration)



ABOVE 1G

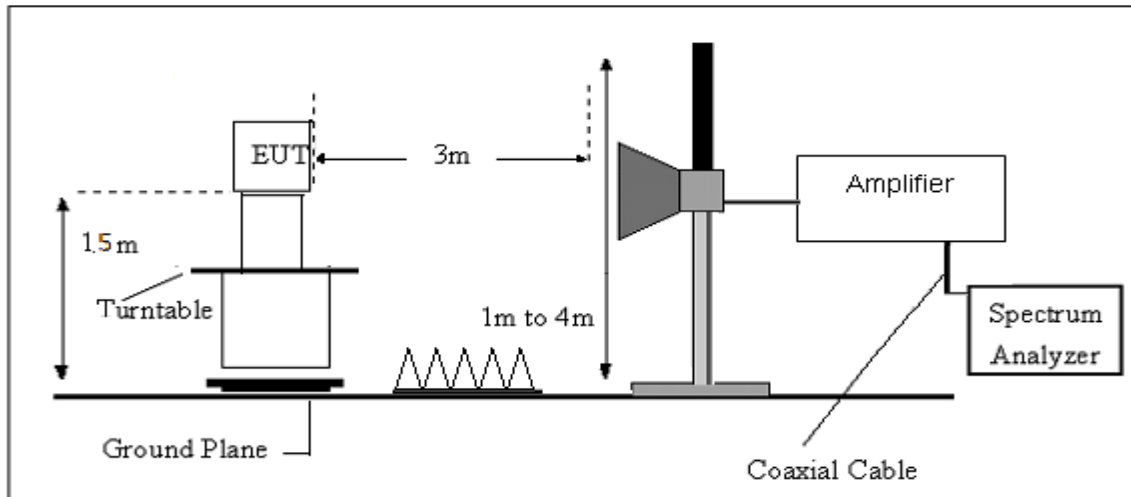

The setting of the spectrum analyser

RBW	1M
VBW	PEAK: 3M AVG: see note 6
Sweep	Auto
Detector	Peak
Trace	Max hold

1. The testing follows the guidelines in ANSI C63.10-2013.
2. The EUT was arranged to its worst case and then tune the antenna tower (from 1 m to 4 m) and turntable (from 0 degree to 360 degrees) to find the maximum reading. A pre-amp and a high pass filter are used for the test in order to get better signal level. Both horizontal and vertical polarizations of the antenna are set to make the measurement.
3. The EUT was placed on a turntable with 1.5m above ground.
4. The EUT was set 3 meters from the interference receiving antenna, which was mounted on the top of a variable height antenna tower.
5. For measurement above 1GHz, the emission measurement will be measured by the peak detector. This peak level, once corrected, must comply with the limit specified in Section 15.209.
6. For measurements above 1 GHz the resolution bandwidth is set to 1 MHz, then the video bandwidth is set to 3 MHz for peak measurements and 1 MHz resolution bandwidth with 1/T video bandwidth with peak detector for average measurements.
7. For the actual test configuration, please refer to the related item in this test report (Photographs of the Test Configuration)

X axis, Y axis, Z axis positions:

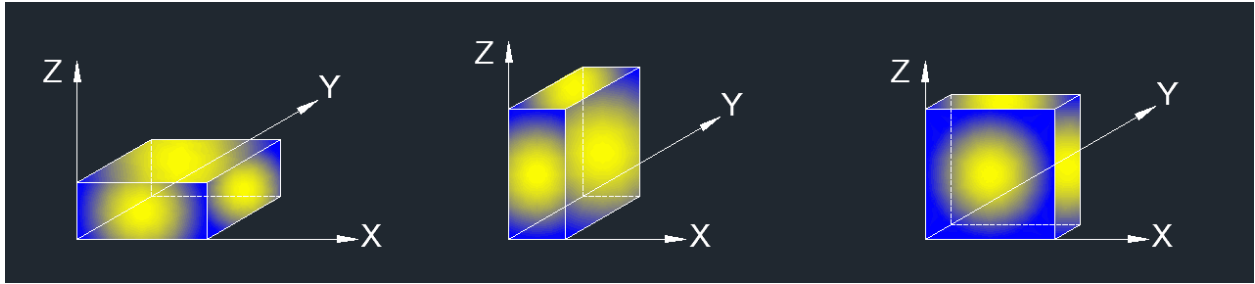

8.The EUT as shown in Figure 1 is the worst mode, the report only shown the worst mode data.

**TEST ENVIRONMENT**

Temperature	25C	Relative Humidity	60%
Atmosphere Pressure	101kPa	Test Voltage	AC 120V 60Hz

## 9.2. RESTRICTED BANDEDGE OQPSK

### RESTRICTED BANDEDGE (LOW CHANNEL, HORIZONTAL)

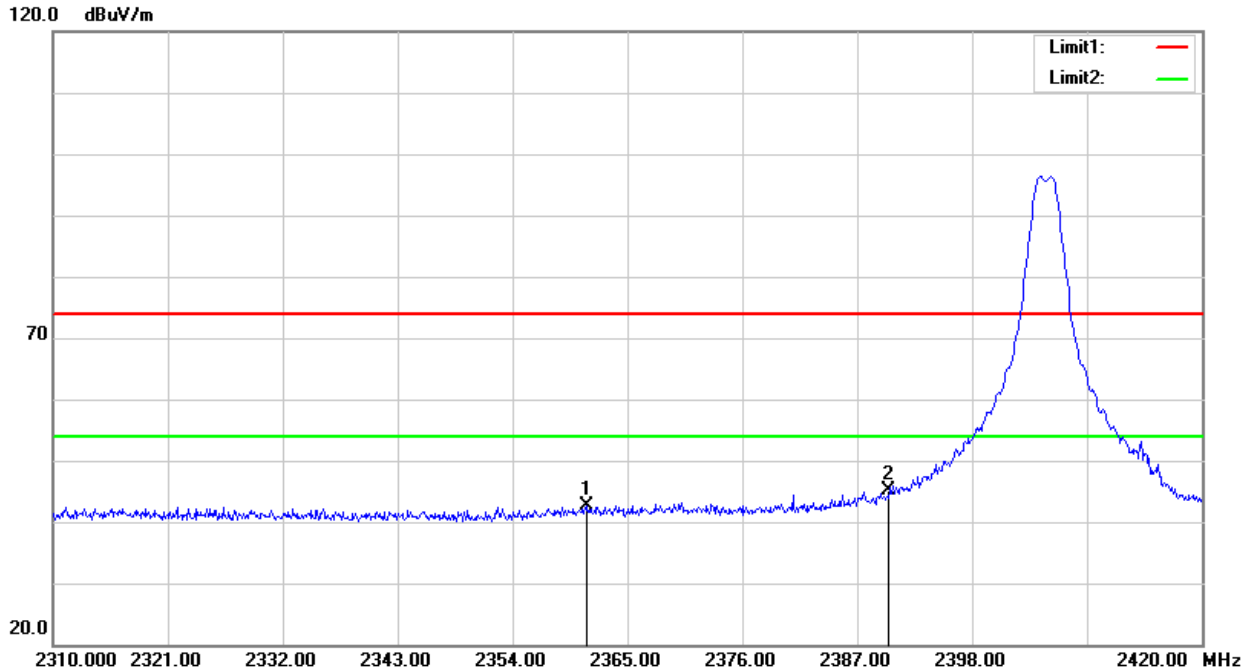

No.	Frequency (MHz)	Reading (dBuV/m)	Correct (dB/m)	Result (dBuV/m)	Limit (dBuV/m)	Margin (dB)	Remark
1	2361.150	38.81	3.91	42.72	74.00	-31.28	peak
2	2390.000	40.84	4.34	45.18	74.00	-28.82	peak

Note: Measurement = Reading Level + Correct Factor.



**RESTRICTED BANDEDGE (LOW CHANNEL, VERTICAL)**

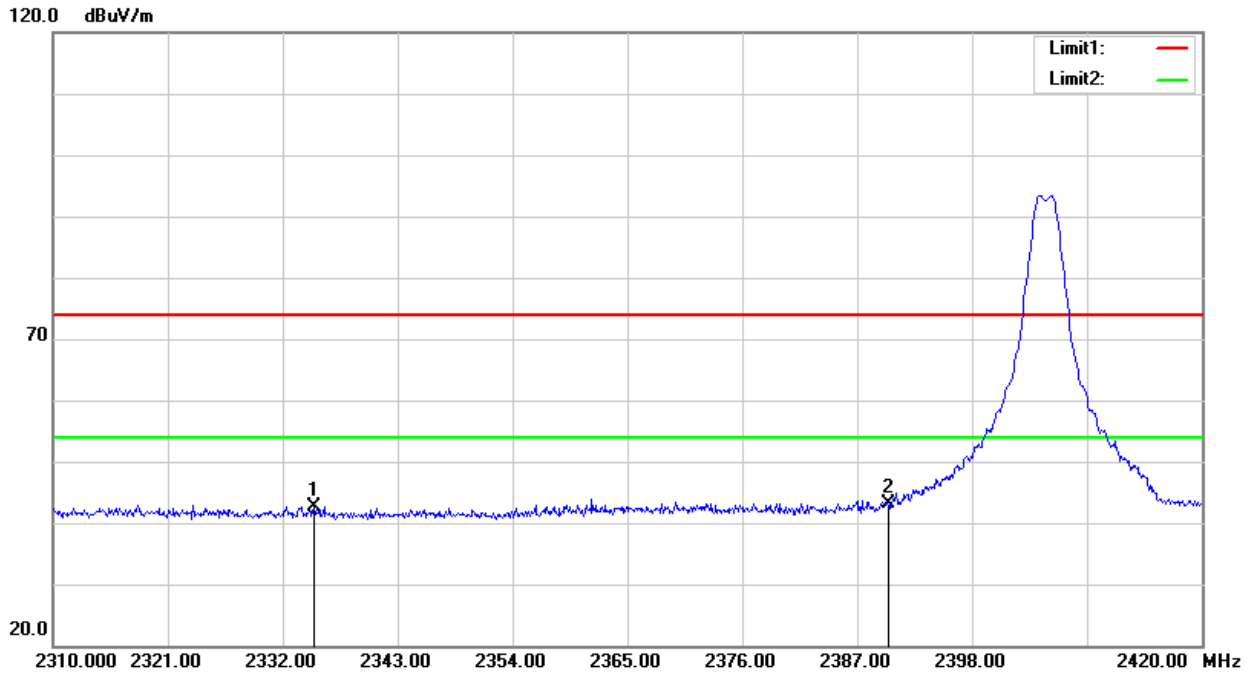

No.	Frequency (MHz)	Reading (dBuV/m)	Correct (dB/m)	Result (dBuV/m)	Limit (dBuV/m)	Margin (dB)	Remark
1	2334.970	39.04	3.66	42.70	74.00	-31.30	peak
2	2390.000	38.87	4.34	43.21	74.00	-30.79	peak

Note: Measurement = Reading Level + Correct Factor.



**RESTRICTED BANDEDGE (HIGH CHANNEL, HORIZONTAL)**

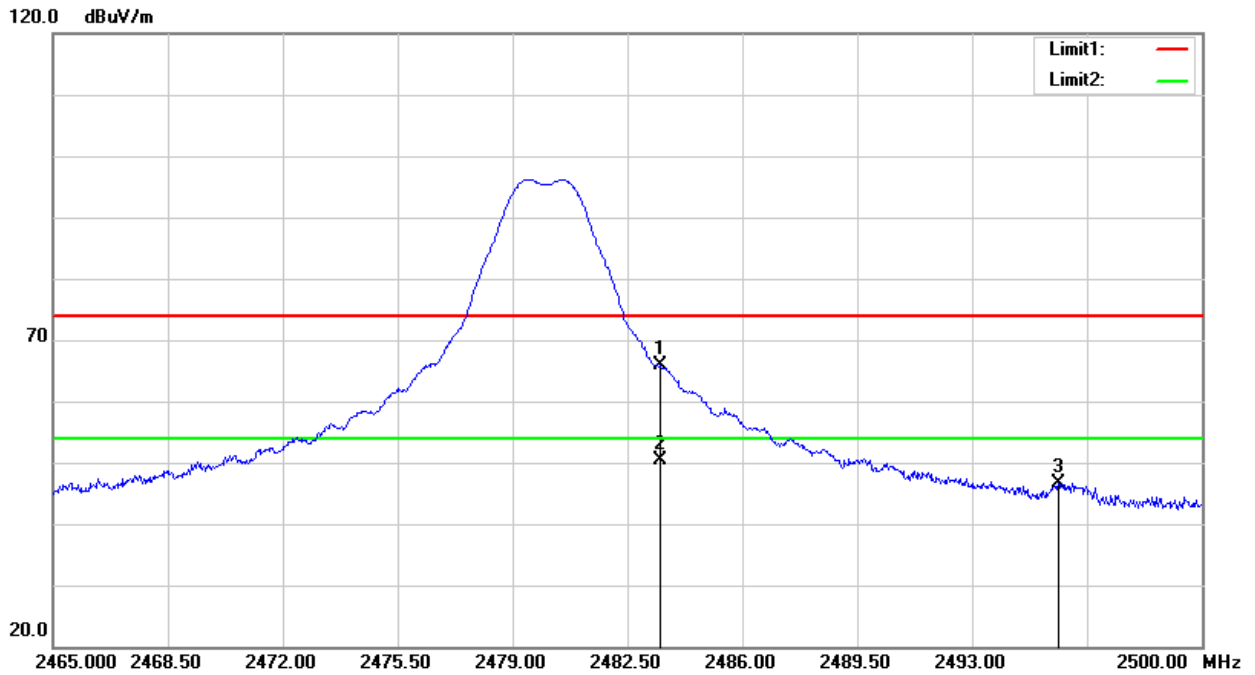

No.	Frequency (MHz)	Reading (dBuV/m)	Correct dB/m	Result (dBuV/m)	Limit (dBuV/m)	Margin (dB)	Remark
1	2483.500	61.22	4.60	65.82	74.00	-8.18	peak
2	2483.500	45.70	4.60	50.30	54.00	-3.70	AVG
3	2495.625	42.08	4.64	46.72	74.00	-27.28	peak

Note: Measurement = Reading Level + Correct Factor.



**RESTRICTED BANDEDGE (HIGH CHANNEL, VERTICAL)**

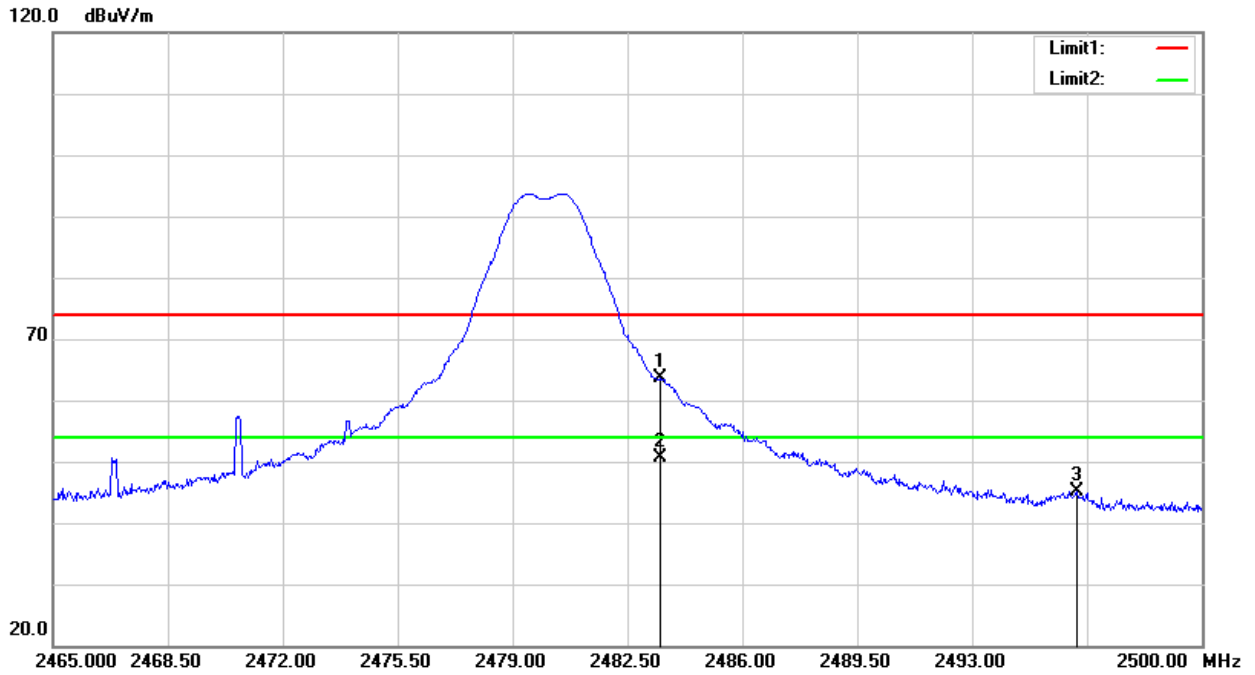

No.	Frequency (MHz)	Reading (dBuV/m)	Correct (dB/m)	Result (dBuV/m)	Limit (dBuV/m)	Margin (dB)	Remark
1	2483.500	58.93	4.60	63.53	74.00	-10.47	peak
2	2483.500	46.01	4.60	50.61	54.00	-3.39	AVG
3	2496.185	40.60	4.64	45.24	74.00	-28.76	peak

Note: Measurement = Reading Level + Correct Factor.

### 9.3. SPURIOUS EMISSIONS 30MHz-1GHz

Note: All the channels had been tested, but only the worst data recorded in the report.

Model: CSC-SC-A-5B-UNVN-WH

#### HARMONICS AND SPURIOUS EMISSIONS (HORIZONTAL)

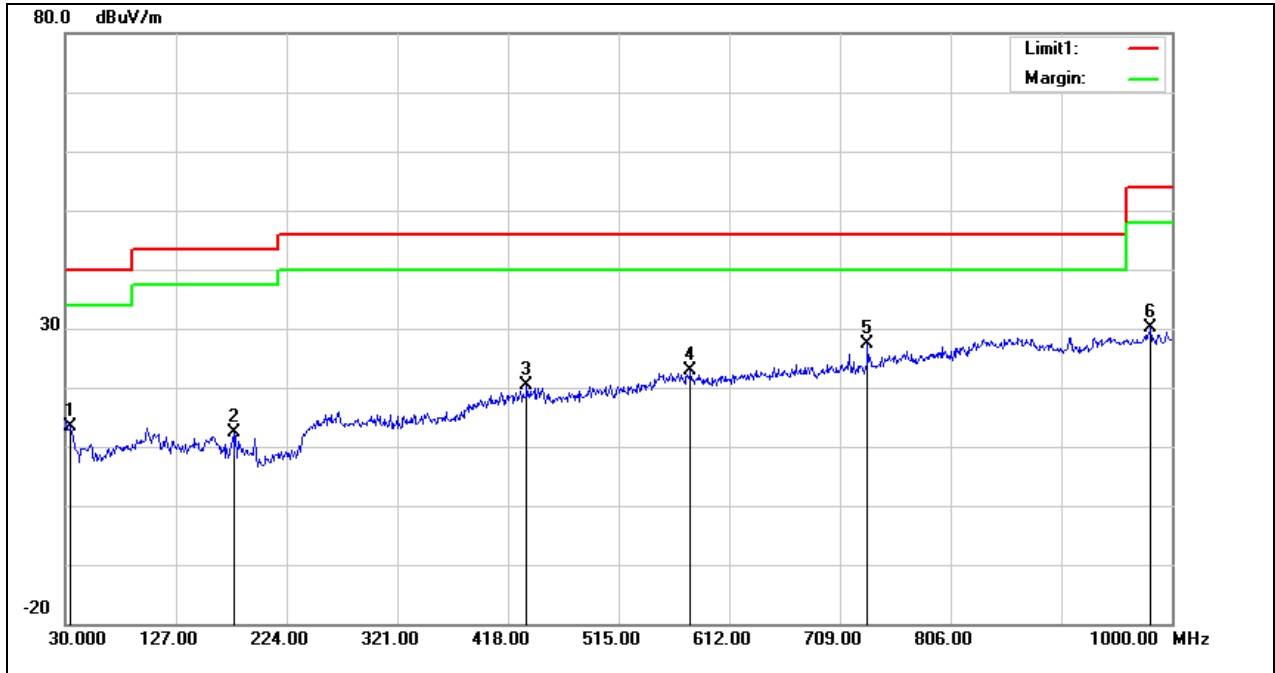

No.	Frequency (MHz)	Reading (dBuV/m)	Correct (dB/m)	Result (dBuV/m)	Limit (dBuV/m)	Margin (dB)	Remark
1	34.8500	28.60	-15.34	13.26	40.00	-26.74	QP
2	177.4400	32.30	-20.03	12.27	43.50	-31.23	QP
3	434.4900	30.57	-10.12	20.45	46.00	-25.55	QP
4	578.0500	28.59	-5.73	22.86	46.00	-23.14	QP
5	733.2500	29.70	-2.35	27.35	46.00	-18.65	QP
6	981.5700	27.63	2.57	30.20	54.00	-23.80	QP

Note: Measurement = Reading Level + Correct Factor.



### HARMONICS AND SPURIOUS EMISSIONS (VERTICAL)

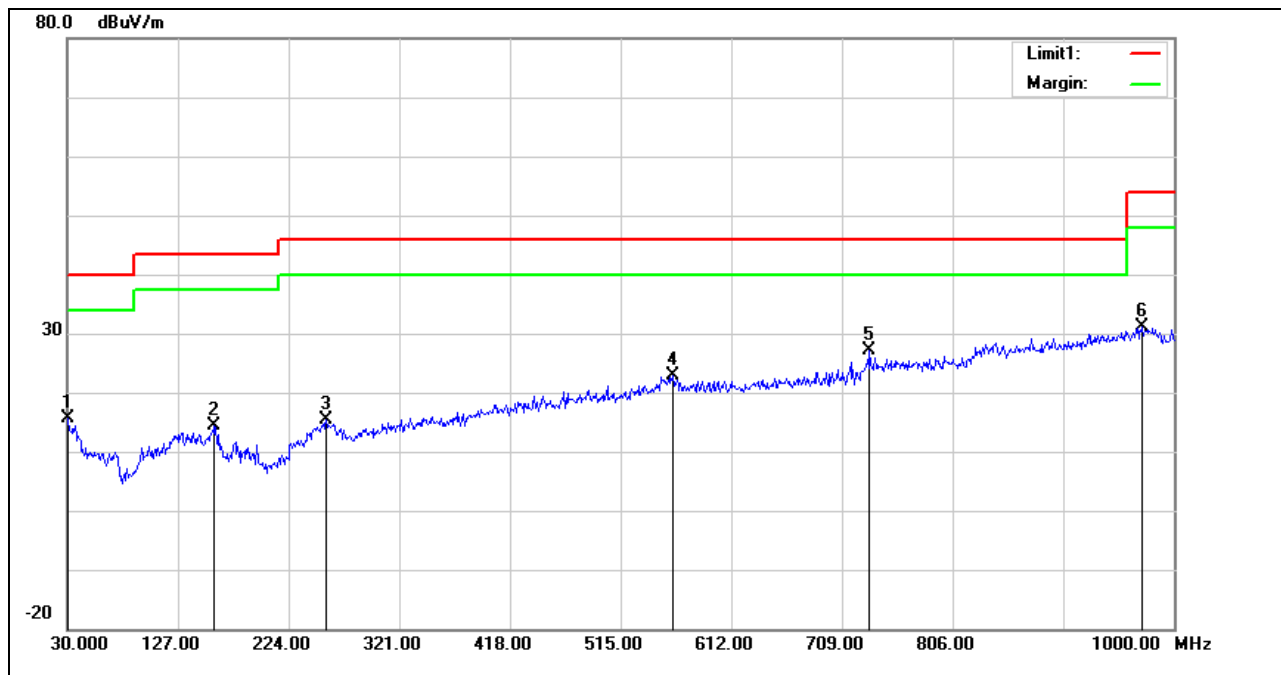

No.	Frequency (MHz)	Reading (dBuV/m)	Correct dB/m	Result (dBuV/m)	Limit (dBuV/m)	Margin (dB)	Remark
1	30.9700	29.01	-13.35	15.66	40.00	-24.34	QP
2	159.0100	33.09	-18.77	14.32	43.50	-29.18	QP
3	256.9800	30.43	-15.13	15.30	46.00	-30.70	QP
4	560.5900	28.41	-5.50	22.91	46.00	-23.09	QP
5	733.2500	29.43	-2.35	27.08	46.00	-18.92	QP
6	971.8700	28.89	2.13	31.02	54.00	-22.98	QP

Note: Measurement = Reading Level + Correct Factor.





Model: CSC-SC-A-5B-UNV-WH

**HARMONICS AND SPURIOUS EMISSIONS (HORIZONTAL)**

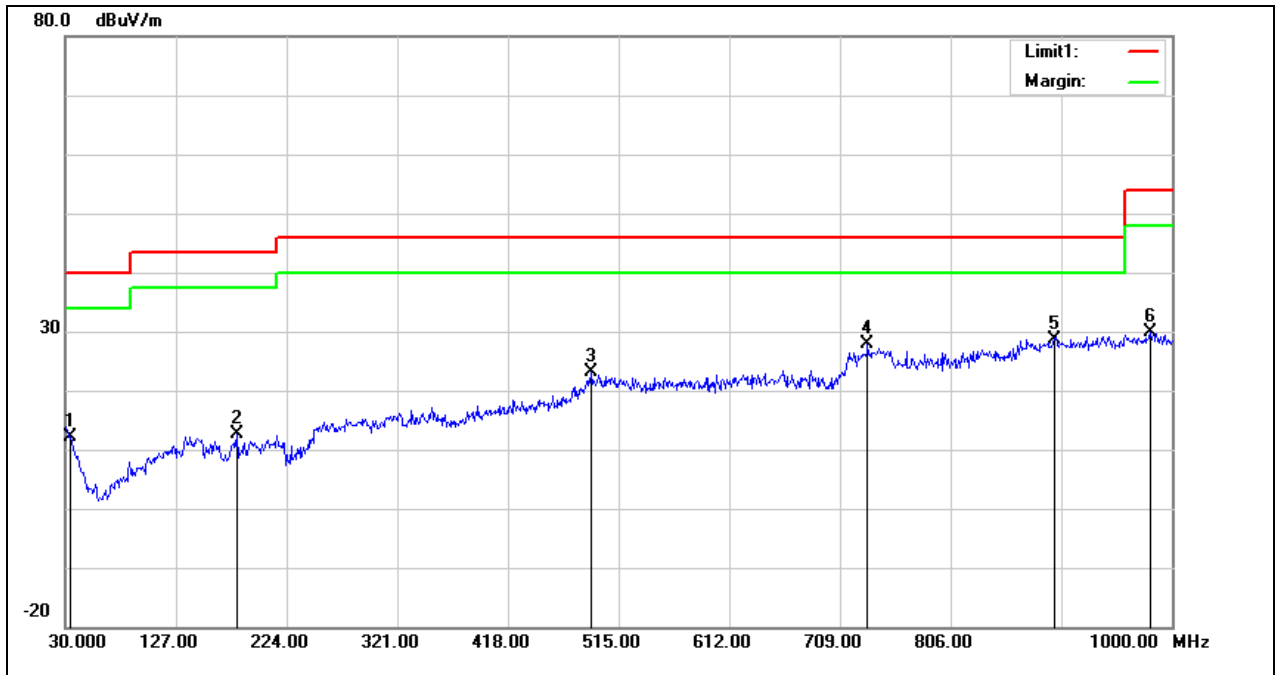

No.	Frequency (MHz)	Reading (dBuV/m)	Correct (dB/m)	Result (dBuV/m)	Limit (dBuV/m)	Margin (dB)	Remark
1	34.8500	27.36	-15.34	12.02	40.00	-27.98	QP
2	180.3500	32.59	-20.04	12.55	43.50	-30.95	QP
3	490.7500	31.26	-8.20	23.06	46.00	-22.94	QP
4	733.2500	30.28	-2.35	27.93	46.00	-18.07	QP
5	897.1800	29.14	-0.52	28.62	46.00	-17.38	QP
6	980.6000	27.19	2.63	29.82	54.00	-24.18	QP

Note: Measurement = Reading Level + Correct Factor.

**HARMONICS AND SPURIOUS EMISSIONS (VERTICAL)**

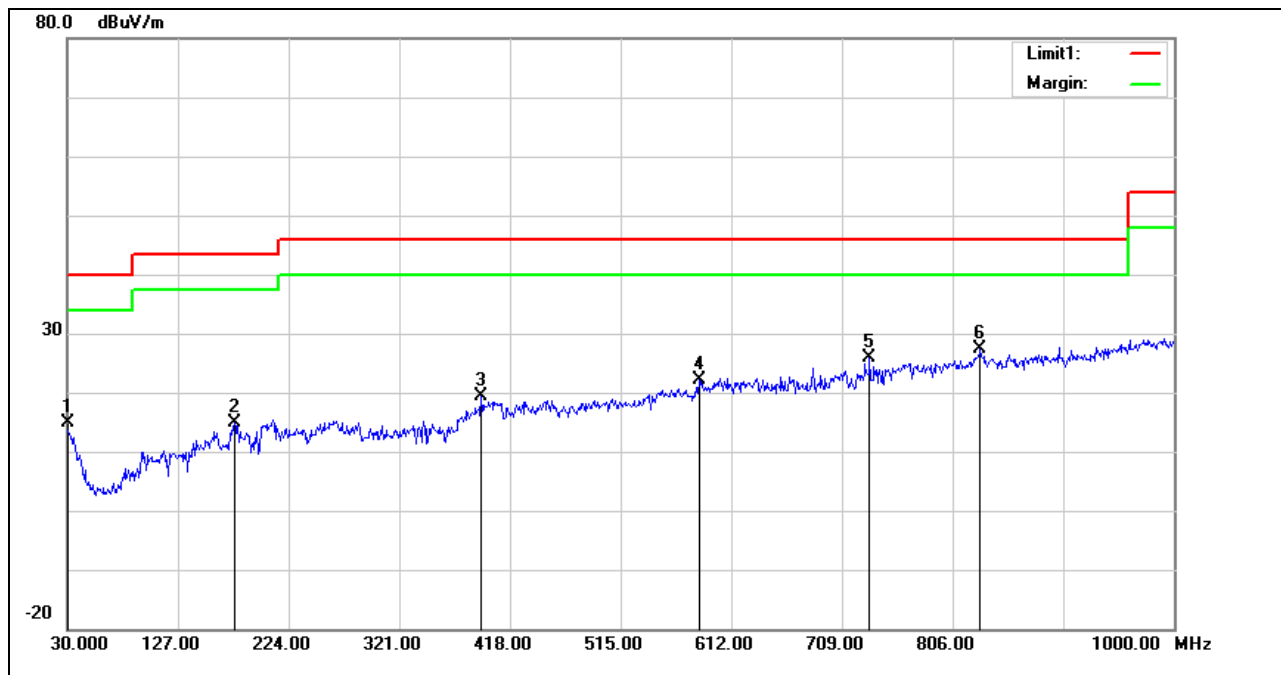

No.	Frequency (MHz)	Reading (dBuV/m)	Correct dB/m	Result (dBuV/m)	Limit (dBuV/m)	Margin (dB)	Remark
1	30.0000	27.73	-12.85	14.88	40.00	-25.12	QP
2	176.4700	35.02	-20.04	14.98	43.50	-28.52	QP
3	392.7800	30.86	-11.46	19.40	46.00	-26.60	QP
4	583.8700	27.90	-5.78	22.12	46.00	-23.88	QP
5	733.2500	28.13	-2.35	25.78	46.00	-20.22	QP
6	830.2500	28.02	-0.74	27.28	46.00	-18.72	QP

Note: Measurement = Reading Level + Correct Factor.

**9.4. SPURIOUS EMISSIONS Above 1 GHz**

Low Channel

Horizontal



Frequency (MHz)	Peak Reading (dBuV/m)	Average Reading (dBuV/m)	Factor (dB)	Peak Level (dBuV/m)	Average Level (dBuV/m)	PK Limit (dBuV/m)	AV Limit (dBuV/m)	PK Over Limit (dB)	AV Over Limit (dB)	Min Margin (dB)
1323.5	40.52	28.67	-0.87	39.65	27.80	74.00	54.00	-34.35	-26.20	-26.20
2890	39.48	28.52	5.61	45.09	34.13	74.00	54.00	-28.91	-19.87	-19.87
4812	52.73	41.16	-6.91	45.82	34.25	74.00	54.00	-28.18	-19.75	-19.75
9620.75	54.49	45.28	5.62	60.11	50.90	74.00	54.00	-13.89	-3.10	-3.10
11004	51.06	40.42	10.2	61.26	50.62	74.00	54.00	-12.74	-3.38	-3.38
14430.5	50.19	40.06	11.06	61.25	51.12	74.00	54.00	-12.75	-2.88	-2.88

### Vertical

Frequency (MHz)	Peak Reading (dBuV/m)	Average Reading (dBuV/m)	Factor (dB)	Peak Level (dBuV/m)	Average Level (dBuV/m)	PK Limit (dBuV/m)	AV Limit (dBuV/m)	PK Over Limit (dB)	AV Over Limit (dB)	Min Margin (dB)
1255	39.88	28.78	-0.91	38.97	27.87	74.00	54.00	-35.03	-26.13	-26.13
2986.5	39.25	28.68	6.05	45.30	34.73	74.00	54.00	-28.70	-19.27	-19.27
5210	52.54	40.67	-4.89	47.65	35.78	74.00	54.00	-26.35	-18.22	-18.22
8738	52.54	41.04	5.04	57.58	46.08	74.00	54.00	-16.42	-7.92	-7.92
11020.5	51.40	40.75	10.11	61.51	50.86	74.00	54.00	-12.49	-3.14	-3.14
14408.5	50.53	40.03	11.32	61.85	51.35	74.00	54.00	-12.15	-2.65	-2.65



## Mid Channel

## Horizontal

Frequency (MHz)	Peak Reading (dBuV/m)	Average Reading (dBuV/m)	Factor (dB)	Peak Level (dBuV/m)	Average Level (dBuV/m)	PK Limit (dBuV/m)	AV Limit (dBuV/m)	PK Over Limit (dB)	AV Over Limit (dB)	Min Margin (dB)
1379.5	40.05	28.94	-0.71	39.34	28.23	74.00	54.00	-34.66	-25.77	-25.77
2941	39.18	28.54	5.84	45.02	34.38	74.00	54.00	-28.98	-19.62	-19.62
5043	52.06	41.41	-6.02	46.04	35.39	74.00	54.00	-27.96	-18.61	-18.61
7321.75	51.42	41.14	3.31	54.73	44.45	74.00	54.00	-19.27	-9.55	-9.55
10976.5	51.03	40.45	10.04	61.07	50.49	74.00	54.00	-12.93	-3.51	-3.51
15019	50.72	40.39	10.38	61.10	50.77	74.00	54.00	-12.90	-3.23	-3.23

## Vertical

Frequency (MHz)	Peak Reading (dBuV/m)	Average Reading (dBuV/m)	Factor (dB)	Peak Level (dBuV/m)	Average Level (dBuV/m)	PK Limit (dBuV/m)	AV Limit (dBuV/m)	PK Over Limit (dB)	AV Over Limit (dB)	Min Margin (dB)
1332	39.89	28.66	-0.84	39.05	27.82	74.00	54.00	-34.95	-26.18	-26.18
2850.5	39.46	28.47	5.61	45.07	34.08	74.00	54.00	-28.93	-19.92	-19.92
4881	52.26	42.79	-6.5	45.76	36.29	74.00	54.00	-28.24	-17.71	-17.71
8716	51.36	41.01	5.11	56.47	46.12	74.00	54.00	-17.53	-7.88	-7.88
10905	51.35	40.62	9.49	60.84	50.11	74.00	54.00	-13.16	-3.89	-3.89
14708.25	50.54	39.24	11.17	61.71	50.41	74.00	54.00	-12.29	-3.59	-3.59



## High Channel

### Horizontal

Frequency (MHz)	Peak Reading (dBuV/m)	Average Reading (dBuV/m)	Factor (dB)	Peak Level (dBuV/m)	Average Level (dBuV/m)	PK Limit (dBuV/m)	AV Limit (dBuV/m)	PK Over Limit (dB)	AV Over Limit (dB)	Min Margin (dB)
1224	39.57	28.55	-1.07	38.50	27.48	74.00	54.00	-35.50	-26.52	-26.52
2893.5	39.51	28.38	5.61	45.12	33.99	74.00	54.00	-28.88	-20.01	-20.01
5148	51.34	40.05	-5.22	46.12	34.83	74.00	54.00	-27.88	-19.17	-19.17
8784.75	51.33	40.90	4.9	56.23	45.80	74.00	54.00	-17.77	-8.20	-8.20
11287.25	51.34	40.26	9.54	60.88	49.80	74.00	54.00	-13.12	-4.20	-4.20
14686.25	49.86	39.10	11.25	61.11	50.35	74.00	54.00	-12.89	-3.65	-3.65

### Vertical

Frequency (MHz)	Peak Reading (dBuV/m)	Average Reading (dBuV/m)	Factor (dB)	Peak Level (dBuV/m)	Average Level (dBuV/m)	PK Limit (dBuV/m)	AV Limit (dBuV/m)	PK Over Limit (dB)	AV Over Limit (dB)	Min Margin (dB)
1169.5	40.07	28.53	-1.32	38.75	27.21	74.00	54.00	-35.25	-26.79	-26.79
2925	39.38	28.25	5.75	45.13	34.00	74.00	54.00	-28.87	-20.00	-20.00
4950	51.75	42.65	-6.38	45.37	36.27	74.00	54.00	-28.63	-17.73	-17.73
8713.25	51.71	40.88	5.12	56.83	46.00	74.00	54.00	-17.17	-8.00	-8.00
10971	50.72	40.35	10	60.72	50.35	74.00	54.00	-13.28	-3.65	-3.65
15008	50.99	40.43	10.39	61.38	50.82	74.00	54.00	-12.62	-3.18	-3.18

Note:

- 1) Factor = Antenna Factor + Cable Loss – Pre-amplifier.  
Emission Level = Reading + Factor
- 2) The frequency emission of peak points that did not show above the forms are at least 20dB below the limit, the frequency emission is mainly from the environment noise.



### 9.5. SPURIOUS EMISSIONS BELOW 30M

Freq.	Reading	Limit	Margin	State	Test Result
(MHz)	(dBuV/m)	(dBuV/m)	(dB)	P/F	
--	--	--	--	--	PASS
--	--	--	--	--	PASS

**Note:**

The amplitude of spurious emissions which are attenuated by more than 20dB below the permissible value has no need to be reported.

Distance extrapolation factor =  $40 \log(\text{specific distance}/\text{test distance})$ (dB);

Limit line = specific limits (dBuV) + distance extrapolation factor.

## 10. AC POWER LINE CONDUCTED EMISSIONS

### LIMITS

Please refer to FCC §15.207 (a) and RSS-Gen Clause 8.8

FREQUENCY (MHz)	Class A (dBuV)		Class B (dBuV)	
	Quasi-peak	Average	Quasi-peak	Average
0.15 -0.5	79.00	66.00	66 - 56 *	56 - 46 *
0.50 -5.0	73.00	60.00	56.00	46.00
5.0 -30.0	73.00	60.00	60.00	50.00

### TEST SETUP AND PROCEDURE

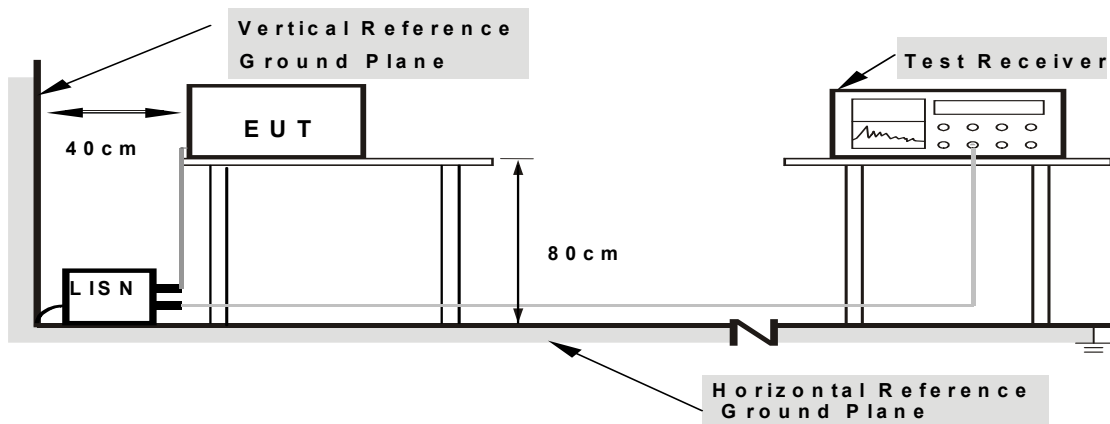

- Note: 1.Support units were connected to second LISN .  
2.Both of LISNs (AMN) are 80 cm from EUT and at least 80 from other units and other metal planes

The EUT is put on a table of non-conducting material that is 80cm high. The vertical conducting wall of shielding is located 40cm to the rear of the EUT. The power line of the EUT is connected to the AC mains through a Artificial Mains Network (A.M.N.). A EMI Measurement Receiver (R&S Test Receiver ESR3) is used to test the emissions from both sides of AC line. According to the requirements in Section 7 and 13 of ANSI C63.10-2013.Conducted emissions from the EUT measured in the frequency range between 0.15 MHz and 30MHz using CISPR Quasi-Peak and average detector mode. The bandwidth of EMI test receiver is set at 9kHz.

The arrangement of the equipment is installed to meet the standards and operating in a manner, which tends to maximize its emission characteristics in a normal application.

### TEST ENVIRONMENT

Temperature	25°C	Relative Humidity	60%
Atmosphere Pressure	101kPa	Test Voltage	AC 120V 60Hz



Model: CSC-SC-A-5B-UNVN-WH

LINE

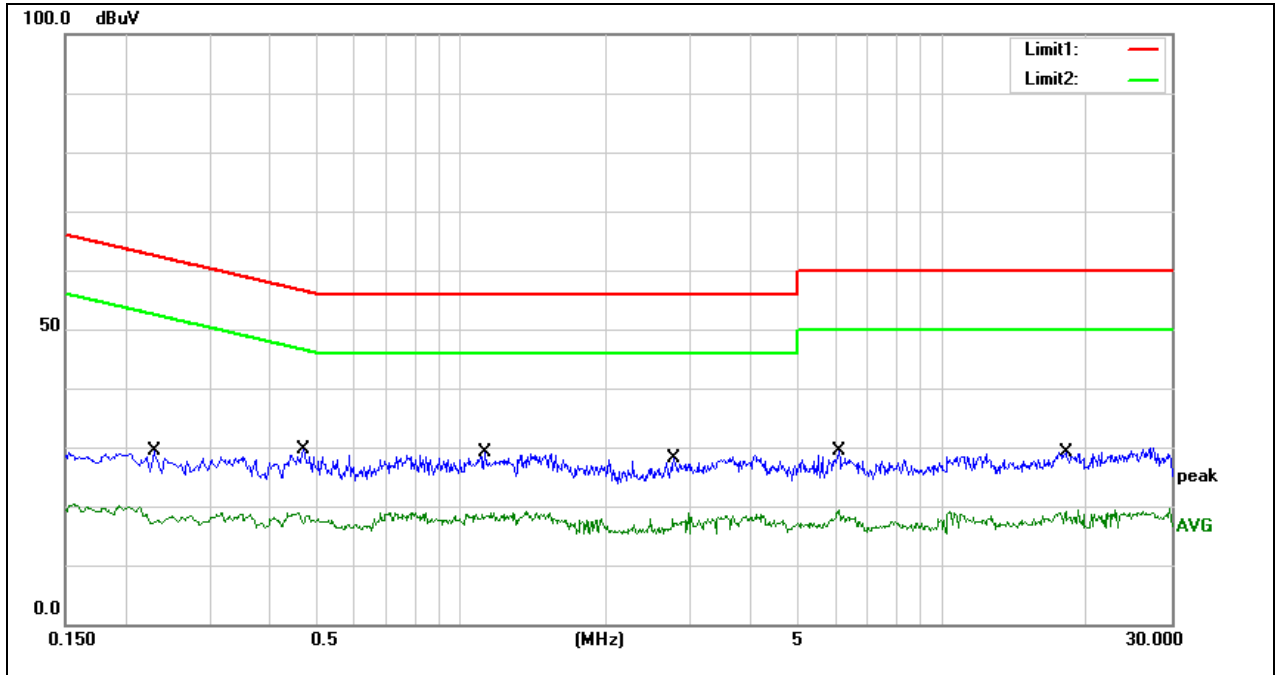

No.	Frequency (MHz)	Reading (dBuV/m)	Correct (dB/m)	Result (dBuV/m)	Limit (dBuV/m)	Margin (dB)	Remark
1	0.2300	8.93	20.46	29.39	62.45	-33.06	QP
2	0.2300	-2.69	20.46	17.77	52.45	-34.68	AVG
3	0.4700	9.18	20.45	29.63	56.51	-26.88	QP
4	0.4700	-2.04	20.45	18.41	46.51	-28.10	AVG
5	1.1180	8.93	20.16	29.09	56.00	-26.91	QP
6	1.1180	-1.35	20.16	18.81	46.00	-27.19	AVG
7	2.7700	8.10	20.09	28.19	56.00	-27.81	QP
8	2.7700	-2.19	20.09	17.90	46.00	-28.10	AVG
9	6.1020	9.44	19.92	29.36	60.00	-30.64	QP
10	6.1020	-0.65	19.92	19.27	50.00	-30.73	AVG
11	18.0540	8.63	20.42	29.05	60.00	-30.95	QP
12	18.0540	-1.37	20.42	19.05	50.00	-30.95	AVG

Note: Measurement = Reading Level + Correct Factor.



**Neutral**

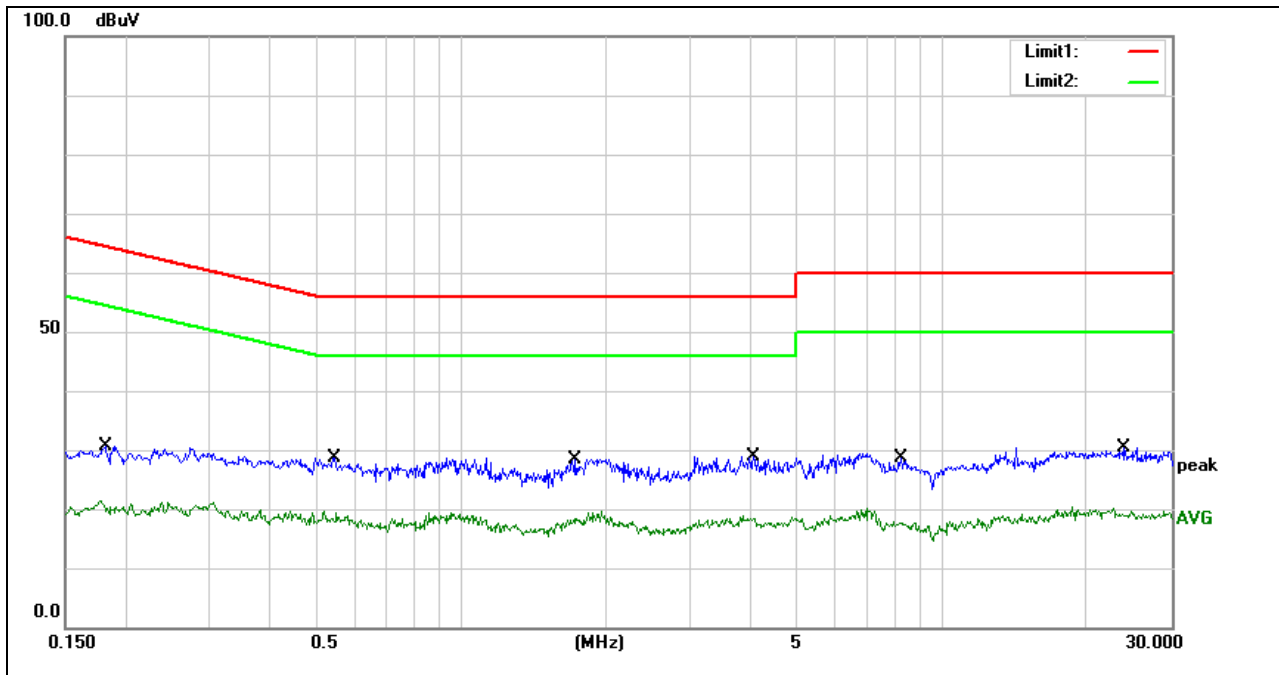

No.	Frequency (MHz)	Reading (dBuV/m)	Correct (dB/m)	Result (dBuV/m)	Limit (dBuV/m)	Margin (dB)	Remark
1	0.1820	10.40	20.28	30.68	64.39	-33.71	QP
2	0.1820	0.32	20.28	20.60	54.39	-33.79	AVG
3	0.5460	8.19	20.39	28.58	56.00	-27.42	QP
4	0.5460	-0.90	20.39	19.49	46.00	-26.51	AVG
5	1.7260	8.24	20.15	28.39	56.00	-27.61	QP
6	1.7260	-1.80	20.15	18.35	46.00	-27.65	AVG
7	4.0500	8.84	20.06	28.90	56.00	-27.10	QP
8	4.0500	-1.61	20.06	18.45	46.00	-27.55	AVG
9	8.2220	8.87	19.88	28.75	60.00	-31.25	QP
10	8.2220	-2.41	19.88	17.47	50.00	-32.53	AVG
11	23.9700	9.71	20.69	30.40	60.00	-29.60	QP
12	23.9700	-1.49	20.69	19.20	50.00	-30.80	AVG

Note: Measurement = Reading Level + Correct Factor.

Model: CSC-SC-A-5B-UNV-WH

LINE

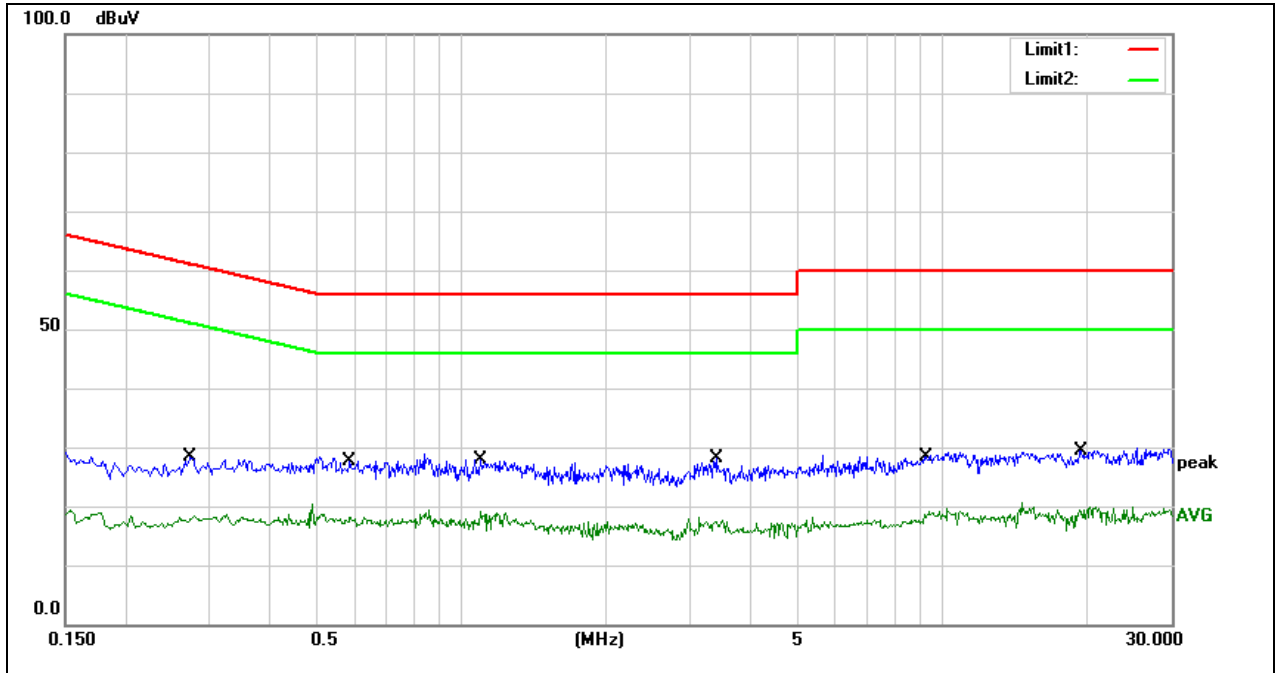

No.	Frequency (MHz)	Reading (dBuV/m)	Correct (dB/m)	Result (dBuV/m)	Limit (dBuV/m)	Margin (dB)	Remark
1	0.2740	7.74	20.65	28.39	61.00	-32.61	QP
2	0.2740	-2.30	20.65	18.35	51.00	-32.65	AVG
3	0.5860	7.37	20.37	27.74	56.00	-28.26	QP
4	0.5860	-2.17	20.37	18.20	46.00	-27.80	AVG
5	1.0980	7.75	20.16	27.91	56.00	-28.09	QP
6	1.0980	-1.04	20.16	19.12	46.00	-26.88	AVG
7	3.3860	8.00	20.07	28.07	56.00	-27.93	QP
8	3.3860	-2.46	20.07	17.61	46.00	-28.39	AVG
9	9.2900	8.50	19.87	28.37	60.00	-31.63	QP
10	9.2900	-0.73	19.87	19.14	50.00	-30.86	AVG
11	19.4500	8.88	20.59	29.47	60.00	-30.53	QP
12	19.4500	-1.21	20.59	19.38	50.00	-30.62	AVG

Note: Measurement = Reading Level + Correct Factor.



**Neutral**

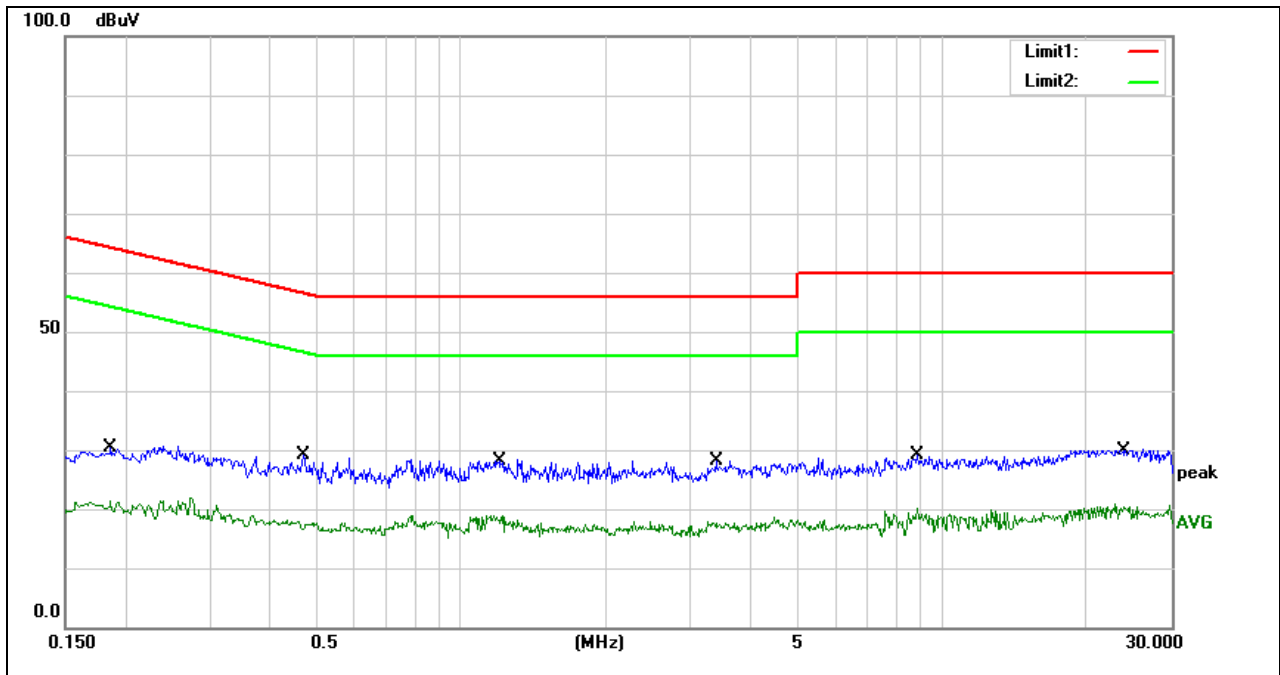

No.	Frequency (MHz)	Reading (dBuV/m)	Correct (dB/m)	Result (dBuV/m)	Limit (dBuV/m)	Margin (dB)	Remark
1	0.1864	10.19	20.29	30.48	64.20	-33.72	QP
2	0.1884	-0.59	20.29	19.70	54.11	-34.41	AVG
3	0.4700	8.68	20.45	29.13	56.51	-27.38	QP
4	0.4700	-3.13	20.45	17.32	46.51	-29.19	AVG
5	1.1980	8.01	20.15	28.16	56.00	-27.84	QP
6	1.1980	-2.75	20.15	17.40	46.00	-28.60	AVG
7	3.3940	7.97	20.07	28.04	56.00	-27.96	QP
8	3.3940	-2.61	20.07	17.46	46.00	-28.54	AVG
9	8.9060	9.37	19.88	29.25	60.00	-30.75	QP
10	8.9060	-1.45	19.88	18.43	50.00	-31.57	AVG
11	23.7620	9.33	20.67	30.00	60.00	-30.00	QP
12	23.7620	-0.23	20.67	20.44	50.00	-29.56	AVG

Note: Measurement = Reading Level + Correct Factor.



## 11. ANTENNA REQUIREMENTS

### APPLICABLE REQUIREMENTS

Please refer to FCC §15.203

If directional gain of transmitting antennas is greater than 6dBi, the power shall be reduced by the same level in dB comparing to gain minus 6dBi. For the fixed point-to-point operation, the power shall be reduced by one dB for every 3 dB that the directional gain of the antenna exceeds 6 dBi. The use of a permanently attached antenna or of an antenna that uses a unique coupling to the intentional radiator shall be considered sufficient to comply with the FCC rule.

### ANTENNA CONNECTOR

EUT has a PCB Antenna without antenna connector.

### ANTENNA GAIN

The antenna gain of EUT is less than 6 dBi.



## **Test photos**

Note: See test photos in setup photo document for the actual connections between Product and support equipment.

**END OF REPORT**