

FCC TEST REPORT  
for  
Shenzhen RDT Digital Technology Co., Ltd.

Bone conduction bluetooth headset  
Model No.: Nice5

Prepared for : Shenzhen RDT Digital Technology Co., Ltd.  
Address : 4/F, Building 2, JiaAn Science & Technology Park, Liuxian 1st  
Road, XinAn Street, 67th District, BaoAn, Shenzhen, China

Prepared By : Shenzhen Anbotek Compliance Laboratory Limited  
Address : 1/F., Building 1, SEC Industrial Park, No.0409 Qianhai Road,  
Nanshan District, Shenzhen, Guangdong, China  
Tel: (86) 755-26066544  
Fax: (86) 755-26014772

Report Number : R011504034I  
Date of Test : Apr. 02~ 21, 2015  
Date of Report : Apr. 22, 2015

## TABLE OF CONTENTS

Description	Page
Test Report	
<b>1. GENERAL INFORMATION.....</b>	<b>5</b>
1.1 Description of Device (EUT).....	5
1.2 Auxiliary Equipment Used during Test.....	6
1.3 Description of Test Facility.....	6
1.4 Measurement Uncertainty.....	6
<b>2. TEST PROCEDURE.....</b>	<b>7</b>
<b>3. CONDUCTED EMISSION.....</b>	<b>8</b>
3.1 Block Diagram of Test Setup.....	8
3.2 Power Line Conducted Emission Measurement Limits (15.207).....	8
3.3 Configuration of EUT on Measurement.....	8
3.4 Operating Condition of EUT.....	8
3.5 Test Procedure.....	9
3.6 Power Line Conducted Emission Measurement Results.....	9
<b>4. RADIATION INTERFERENCE.....</b>	<b>12</b>
4.1 Requirements (15.247, 15.209):.....	12
4.2 Test Procedure.....	12
4.3 Test Configuration.....	13
4.4 Test Results.....	14
<b>5. CHANNEL SEPARATION TEST.....</b>	<b>23</b>
5.1 Measurement Procedure.....	23
5.2 Test SET-UP.....	23
5.3 Test Equipment.....	23
5.4 Test Results.....	24
<b>6. 20DB BANDWIDTH TEST.....</b>	<b>28</b>
6.1 Measurement Procedure.....	28
6.2 Test SET-UP.....	28
6.3 Test Equipment.....	28
6.4 Test Results.....	28
<b>7. QUANTITY OF HOPPING CHANNEL TEST.....</b>	<b>32</b>
7.1 Measurement Procedure.....	32
7.2 Test SET-UP.....	32
7.3 Test Equipment.....	32
7.4 Test Results.....	32
<b>8. DWELL TIME TEST.....</b>	<b>34</b>
8.1 Measurement Procedure.....	34
8.2 Test SET-UP.....	34
8.3 Test Equipment.....	34
8.4 Test Results.....	34
<b>9. MAXIMUM PEAK OUTPUT POWER TEST.....</b>	<b>37</b>
9.1 Measurement Procedure.....	37

9.2 Test SET-UP..... 37  
9.3 Test Equipment..... 37  
9.4 Test Results..... 38  
**10. BAND EDGE TEST..... 42**  
10.1 Measurement Procedure..... 42  
10.2 Test SET-UP..... 42  
10.3 Test Equipment..... 43  
10.4 Test Results..... 43  
**11. ANTENNA APPLICATION..... 49**  
11.1 Antenna requirement..... 49  
11.2 Result..... 49  
**12. PHOTOGRAPH..... 50**  
12.1 Photo of Power Line Conducted Emission Measurement..... 50  
12.2 Photo of Radiation Emission Test..... 50  
**APPENDIX I (EXTERNAL PHOTOS)..... 52**  
**APPENDIX II (INTERNAL PHOTOS)..... 55**

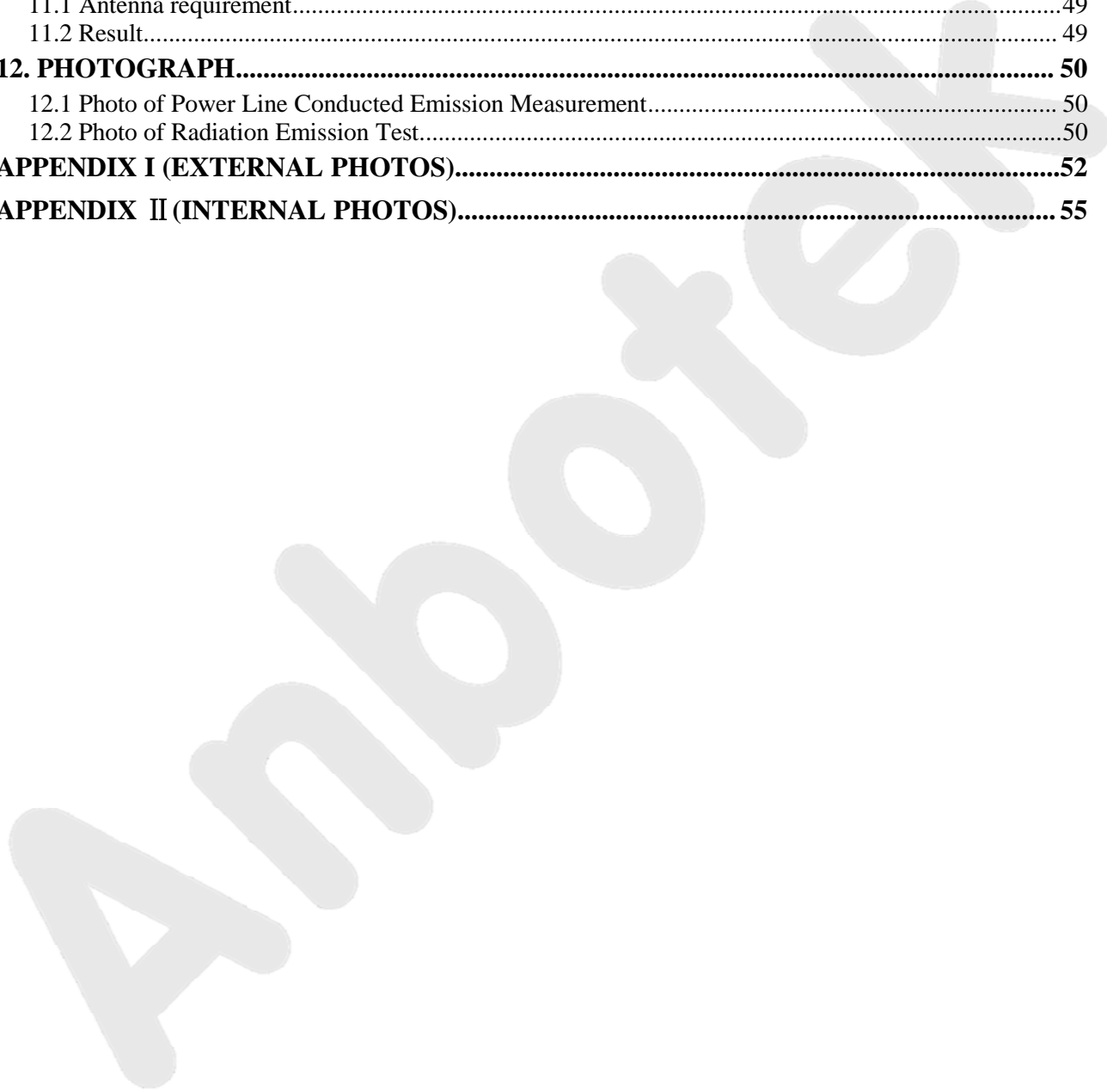

## TEST REPORT

Applicant : Shenzhen RDT Digital Technology Co., Ltd.  
Manufacturer : Shenzhen RDT Digital Technology Co., Ltd.  
EUT : Bone conduction bluetooth headset  
Model No. : Nice5  
Serial No. : N.A.  
Trade Mark : N.A.  
Rating : DC 5V, 300mA

Measurement Procedure Used:

FCC Part15 Subpart C, Paragraph 15.207, 15.247 & 15.209

The device described above is tested by Shenzhen Anbotek Compliance Laboratory Limited to determine the maximum emission levels emanating from the device and the severe levels of the device can endure and its performance criterion. The measurement results are contained in this test report and Shenzhen Anbotek Compliance Laboratory Limited is assumed full of responsibility for the accuracy and completeness of these measurements. Also, this report shows that the EUT (Equipment Under Test) is technically compliant with the FCC Part 15 Subpart C requirements.

This report applies to above tested sample only and shall not be reproduced in part without written approval of Shenzhen Anbotek Compliance Laboratory Limited.

Date of Test : Apr. 02~ 21, 2015

Prepared by :

*Kebo Zhang*

(Tested Engineer / Kebo Zhang)

*Amy Ding*

Reviewer :

(Project Manager / Amy Ding)

*Tom Chen*

Approved & Authorized Signer :

(Manager / Tom Chen)

## 1. GENERAL INFORMATION

### 1.1 Description of Device (EUT)

EUT	: Bone conduction bluetooth headset
Model Number	: Nice5
Test Power Supply	: DC 5V via adapter AC 120V, 60Hz/ DC 5V(With DC 3.7V Battery inside)
Frequency	: 2402~2480MHz
Antenna Specification	: Chip Antenna: 0dBi
Modulation	: GFSK, $\pi/4$ DQPSK, 8DPSK
Applicant Address	: Shenzhen RDT Digital Technology Co., Ltd. : 4/F, Building 2, JiaAn Science & Technology Park, Liuxian 1st Road, XinAn Street, 67th District, BaoAn, Shenzhen, China
Manufacturer Address	: Shenzhen RDT Digital Technology Co., Ltd. : 4/F, Building 2, JiaAn Science & Technology Park, Liuxian 1st Road, XinAn Street, 67th District, BaoAn, Shenzhen, China
Factory Address	: Shenzhen RDT Digital Technology Co., Ltd. : 4/F, Building 2, JiaAn Science & Technology Park, Liuxian 1st Road, XinAn Street, 67th District, BaoAn, Shenzhen, China
Date of receipt	: Apr. 02, 2015
Date of Test	: Apr. 02~ 21, 2015

## 1.2 Auxiliary Equipment Used during Test

Adapter : Power Supply  
Model:MX12L3-0502000V  
Input: AC 100-240V, 50-60Hz, 0.35A  
Output: DC 3.7V, 2A  
CE , FCC

## 1.3 Description of Test Facility

The test facility is recognized, certified, or accredited by the following organizations:

### **CNAS - LAB Code: L3503**

Shenzhen Anbotek Compliance Laboratory Limited., Laboratory has been assessed and in compliance with CNAS/CL01: 2006 accreditation criteria for testing laboratories (identical to ISO/IEC 17025:2005 General Requirements) for the Competence of Testing Laboratories.

### **FCC-Registration No.: 752021**

Shenzhen Anbotek Compliance Laboratory Limited, EMC Laboratory has been registered and fully described in a report filed with the (FCC) Federal Communications Commission. The acceptance letter from the FCC is maintained in our files. Registration 752021, July 10, 2013.

### **IC-Registration No.: 8058A-1**

Shenzhen Anbotek Compliance Laboratory Limited., EMC Laboratory has been registered and fully described in a report filed with the (IC) Industry Canada. The acceptance letter from the IC is maintained in our files. Registration 8058A, February 22, 2013.

### **Test Location**

All Emissions tests were performed at  
Shenzhen Anbotek Compliance Laboratory Limited. at 1/F., Building 1, SEC Industrial Park, No.0409 Qianhai Road, Nanshan District, Shenzhen, Guangdong, China

## 1.4 Measurement Uncertainty

Radiation Uncertainty : Ur = 4.1 dB (Horizontal)  
Ur = 4.3 dB (Vertical)  
Conduction Uncertainty : Uc = 3.4dB

## 2. Test Procedure

**GENERAL:** This report shall NOT be reproduced except in full without the written approval of Shenzhen Anbotek Compliance Laboratory Limited. The EUT was transmitting a test signal during the testing.

**RADIATION INTERFERENCE:** The test procedure used was ANSI STANDARD C63.10-2013 using a spectrum analyzer with a pre-selector. The analyzer was calibrated in dB above a microvolt at the output of the antenna. The resolution bandwidth was 100KHz and the video bandwidth was 300KHz up to 1.0GHz and 1.0MHz with a video BW of 3.0MHz above 1.0GHz. The ambient temperature of the EUT was 74.3oF with a humidity of 69%.

**FORMULA OF CONVERSION FACTORS:** The Field Strength at 3m was established by adding the meter reading of the spectrum analyzer (which is set to read in units of dBuV) to the antenna correction factor supplied by the antenna manufacturer. The antenna correction factors are stated in terms of dB. The gain of the Preselector was accounted for in the Spectrum Analyzer Meter Reading.

**Example:**

Freq (MHz) METER READING + ACF = FS  
20 dBuV + 10.36 dB = 30.36 dBuV/m @ 3m

**ANSI STANDARD C63.10-2013 10.1.7 MEASUREMENT PROCEDURES:** The EUT was placed on a table 80 cm high and with dimensions of 1m by 1.5m. The EUT was placed in the center of the table (1.5m side). The table used for radiated measurements is capable of continuous rotation.

When an emission was found, the table was rotated to produce the maximum signal strength. At this point, the antenna was raised and lowered from 1m to 4m. The antenna was placed in both the horizontal and vertical planes.

### 3. Conducted Emission

#### 3.1 Block Diagram of Test Setup

3.1.1. Block diagram of connection between the EUT and simulators

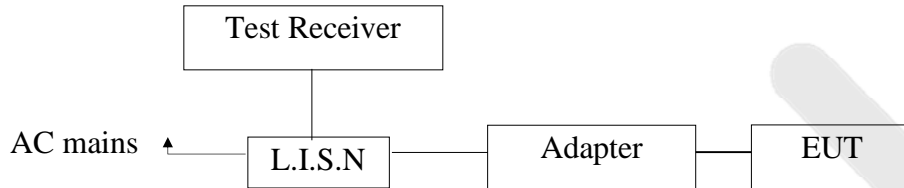

#### 3.2 Power Line Conducted Emission Measurement Limits (15.207)

Frequency MHz	Limits dB(μV)	
	Quasi-peak Level	Average Level
0.15 ~ 0.50	66 ~ 56*	56 ~ 46*
0.50 ~ 5.00	56	46
5.00 ~ 30.00	60	50

Notes: 1. \*Decreasing linearly with logarithm of frequency.  
2. The lower limit shall apply at the transition frequencies.

#### 3.3 Configuration of EUT on Measurement

The following equipments are installed on Power Line Conducted Emission Measurement to meet the commission requirement and operating regulations in a manner which tends to maximize its emission characteristics in a normal application.

#### 3.4 Operating Condition of EUT

3.4.1. Setup the EUT and simulator as shown as Section 3.1.

3.4.2. Turn on the power of all equipment.

3.4.3. Let the EUT work in test mode (Charging to adapter) and measure it.



### 3.5 Test Procedure

The EUT system is connected to the power mains through a line impedance stabilization network (L.I.S.N.). This provides a 50ohm coupling impedance for the EUT system. Please refer the block diagram of the test setup and photographs. Both sides of AC line are checked to find out the maximum conducted emission. In order to find the maximum emission levels, the relative positions of equipment and all of the interface cables shall be changed according to FCC ANSI C63.10-2013 on Conducted Emission Measurement.

The bandwidth of test receiver (ESCI) set at 9KHz.

The frequency range from 150KHz to 30MHz is checked.

The test results are reported on Section 3.6.

#### Test Equipment

Item	Equipment	Manufacturer	Model No.	Serial No.	Last Cal.	Cal. Interval
1.	Two-Line V-network	Rohde & Schwarz	ENV216	100055	Apr. 22, 2014	1 Year
2.	EMI Test Receiver	Rohde & Schwarz	ESCI	100627	Apr. 22, 2014	1 Year
3.	RF Switching Unit	Compliance Direction	RSU-M2	38303	Apr. 22, 2014	1 Year

### 3.6 Power Line Conducted Emission Measurement Results

**PASS.**

The frequency range from 150KHz to 30 MHz is investigated.

Please refer the following pages.

**CONDUCTED EMISSION TEST DATA**

Test Site: 1# Shielded Room  
 Operating Condition: Charging to adapter  
 Test Specification: DC 5V via adapter AC 120V, 60Hz  
 Comment: Live Line  
 Tem:25°C Hum:50%

**SCAN TABLE: "Voltage (150K~30M) FIN"**

Short Description: 150K-30M Disturbance Voltages

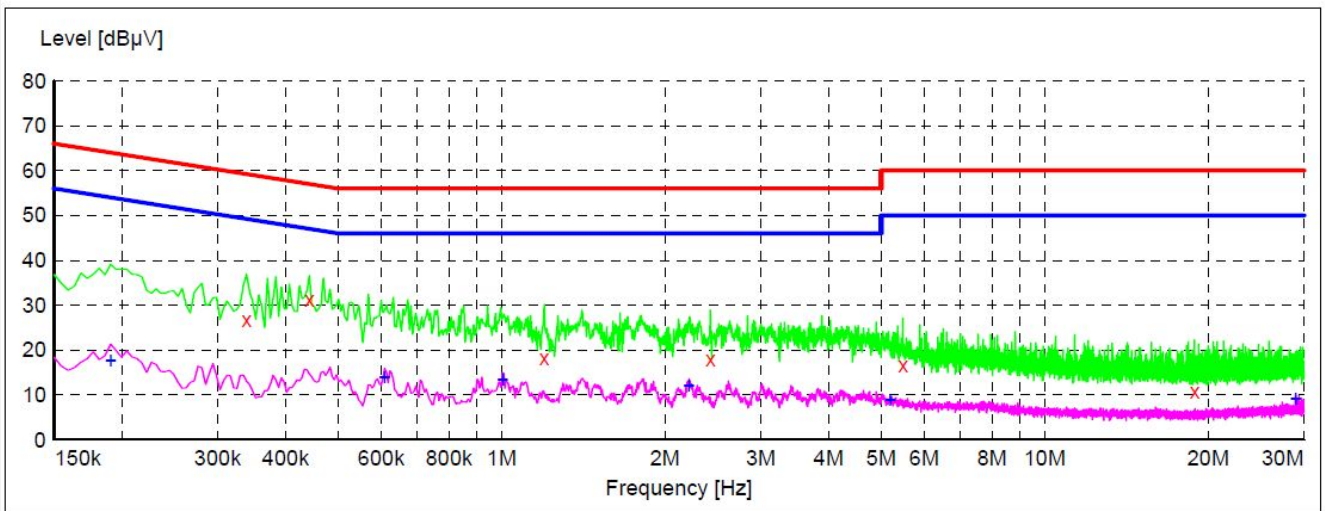

Frequency MHz	Level dBµV	Transd dB	Limit dBµV	Margin dB	Detector	Line	PE
0.339000	26.60	20.1	59	32.6	QP	L1	GND
0.442500	31.20	20.1	57	25.8	QP	L1	GND
1.198000	18.10	20.2	56	37.9	QP	L1	GND
2.422000	18.00	20.3	56	38.0	QP	L1	GND
5.482000	16.50	20.5	60	43.5	QP	L1	GND
18.874000	10.70	20.8	60	49.3	QP	L1	GND

Frequency MHz	Level dBµV	Transd dB	Limit dBµV	Margin dB	Detector	Line	PE
0.190500	17.60	20.1	54	36.4	AV	L1	GND
0.609000	13.90	20.1	46	32.1	AV	L1	GND
1.004500	13.50	20.2	46	32.5	AV	L1	GND
2.215000	12.00	20.3	46	34.0	AV	L1	GND
5.194000	9.00	20.5	50	41.0	AV	L1	GND
28.999000	9.30	20.9	50	40.7	AV	L1	GND

**CONDUCTED EMISSION TEST DATA**

Test Site: 1# Shielded Room  
 Operating Condition: Charging to adapter  
 Test Specification: DC 5V via adapter AC 120V, 60Hz  
 Comment: Neutral Line  
 Tem:25°C Hum:50%

**SCAN TABLE: "Voltage (150K~30M) FIN"**

Short Description: 150K-30M Disturbance Voltages

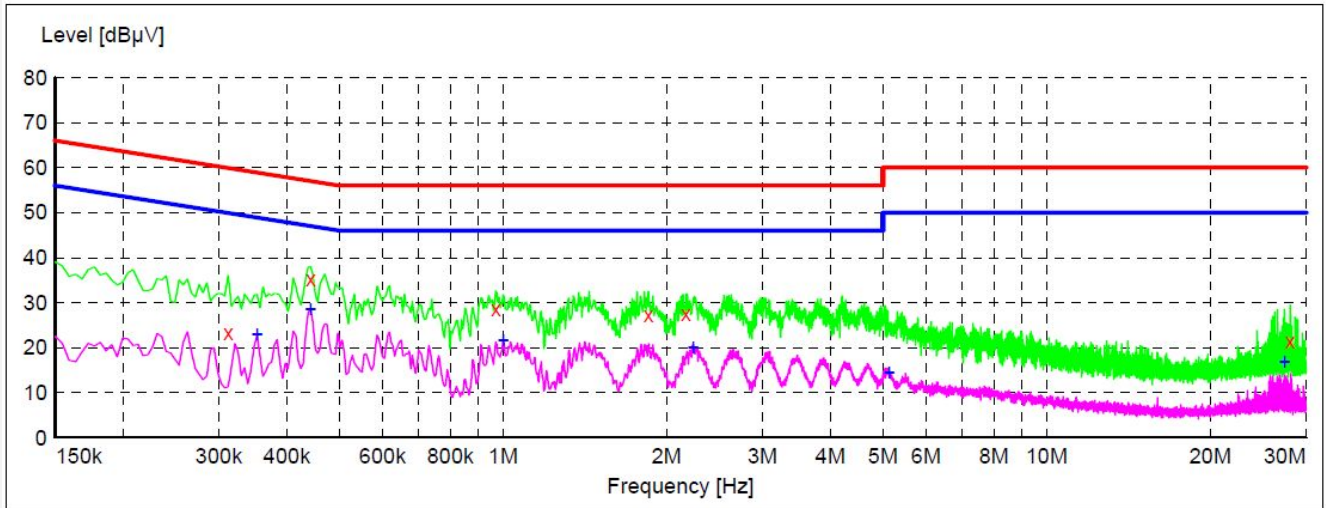

Frequency MHz	Level dBµV	Transd dB	Limit dBµV	Margin dB	Detector	Line	PE
0.312000	23.20	20.1	60	36.7	QP	N	GND
0.442500	35.30	20.1	57	21.7	QP	N	GND
0.969000	28.70	20.2	56	27.3	QP	N	GND
1.850500	27.30	20.3	56	28.7	QP	N	GND
2.170000	27.50	20.3	56	28.5	QP	N	GND
28.036000	21.40	20.9	60	38.6	QP	N	GND

Frequency MHz	Level dBµV	Transd dB	Limit dBµV	Margin dB	Detector	Line	PE
0.352500	22.90	20.1	49	26.0	AV	N	GND
0.442500	28.70	20.1	47	18.3	AV	N	GND
1.000000	21.70	20.2	46	24.3	AV	N	GND
2.237500	20.20	20.3	46	25.8	AV	N	GND
5.131000	14.60	20.5	50	35.4	AV	N	GND
27.437500	16.90	20.9	50	33.1	AV	N	GND

## 4. Radiation Interference

### 4.1 Requirements (15.247, 15.209):

#### 4.1.1. Test Limits (< 30 MHz)

Frequency (MHz)	Field Strength (microvolts/meter)	Measurement Distance (meter)
0.009-0.490	2400/F(kHz)	300
0.490-1.705	24000/F(kHz)	30
1.705-30.0	30	30

#### 4.1.2. Test Limits (≥ 30 MHz)

FIELD STRENGTH of Fundamental: @3M	FIELD STRENGTH of Harmonics	S15.209	
902-928 MHz		30 - 88 MHz	40 dBuV/m
2.4-2.4835 GHz		88 - 216 MHz	43.5
94 dBμV/m @3m	54 dBμV/m @3m	216 - 960 MHz	46
		ABOVE 960 MHz	54dBuV/m

For range 9KHz~30MHz, The measured value is really too low to be recorded.

Emissions radiated outside of the specified frequency bands, except for harmonics, shall be attenuated by at least 50 dB below the level of the fundamental or to the general radiated emission limits in 15.209, whichever is the lesser attenuation.

### 4.2 Test Procedure

The EUT is placed on a turn table which is 0.8 meter high above the ground. The turn table can rotate 360 degrees to determine the position of the maximum emission level. The EUT is set 3 meters away from the receiving antenna which is mounted on a antenna tower. The antenna can be moved up and down from 1 to 4 meters to find out the maximum emission level. Rotated the EUT through three orthogonal axes to determine the maximum emissions, both horizontal and vertical polarization of the antenna are set on test. The EUT is tested in 9\*6\*6 Chamber.

#### **For 30MHz to 1000MHz:**

Set the spectrum analyzer as:  
 RBW = 100kHz, VBW =300kHz,  
 Detector= Quasi-Peak  
 Trace mode= Max hold.  
 Sweep- auto couple.

#### **For Above 1GHz:**

Set the spectrum analyzer as:  
 RBW = 1MHz, VBW =3MHz,  
 Detector= Peak  
 Trace mode= Max hold.  
 Sweep- auto couple.

Set the spectrum analyzer as:  
RBW =1MHz, VBW =10Hz  
Detector= Average  
Trace mode= Max hold.  
Sweep- auto couple.

Test Equipment

Item	Equipment	Manufacturer	Model No.	Serial No.	Last Cal.	Cal. Interval
1.	Spectrum Analysis	Agilent	E4407B	US39390582	Aug. 08, 2014	1 Year
2.	Preamplifier	Instruments corporation	EMC011830	980100	Aug. 08, 2014	1 Year
3.	EMI Test Receiver	Rohde & Schwarz	ESPI	101604	Apr. 22, 2014	1 Year
4.	Double Ridged Horn Antenna	Instruments corporation	GTH-0118	351600	Apr. 22, 2014	1 Year
5.	Bilog Broadband Antenna	Schwarzbeck	VULB9163	VULB 9163-289	Apr. 24, 2014	1 Year
6.	Pre-amplifier	SONOMA	310N	186860	Aug. 08, 2014	1 Year
7.	EMI Test Software EZ-EMC	SHURPLE	N/A	N/A	N/A	N/A

4.3 Test Configuration

4.3.1. 9k to 30MHz emissions:

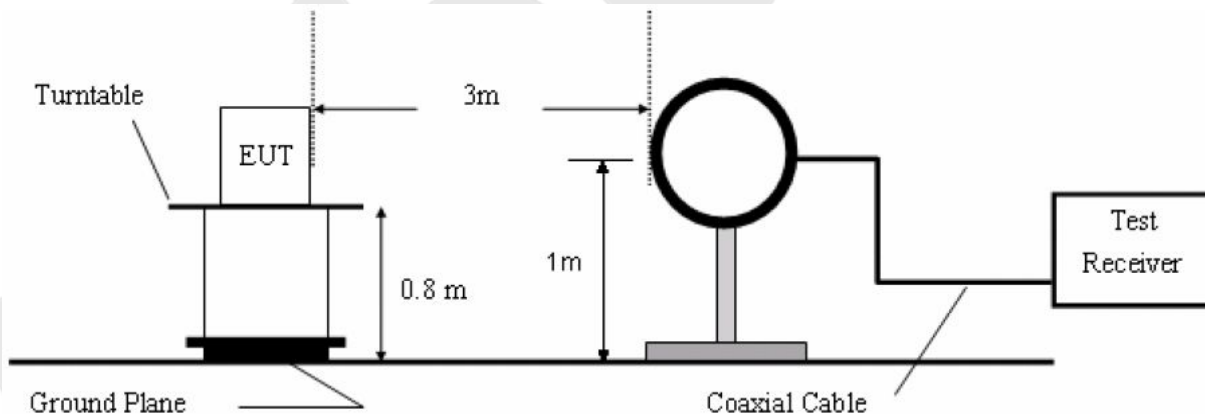

4.3.2. 30M to 1G emissions:

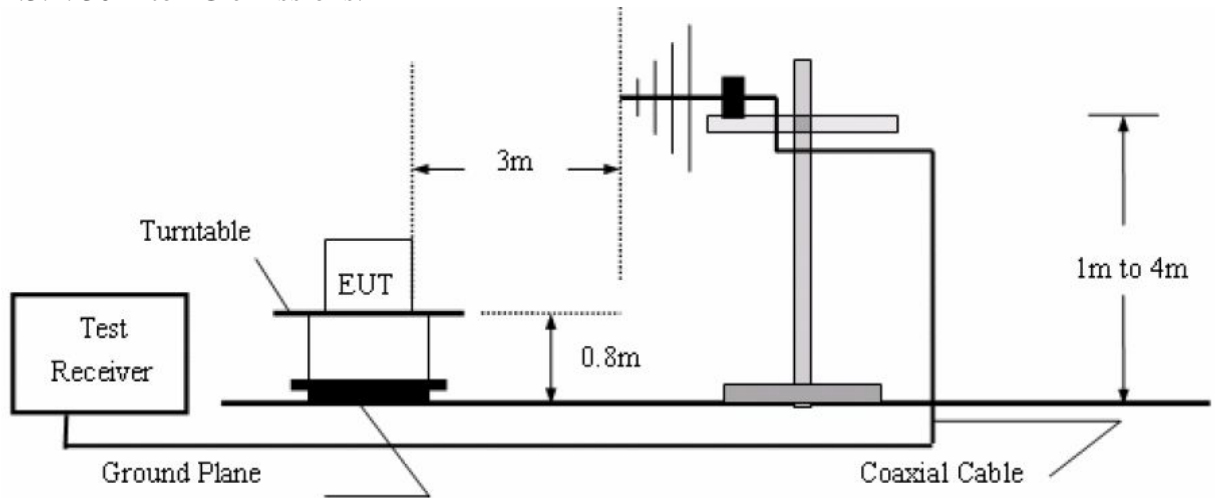

4.3.3. 1G to 40G emissions:

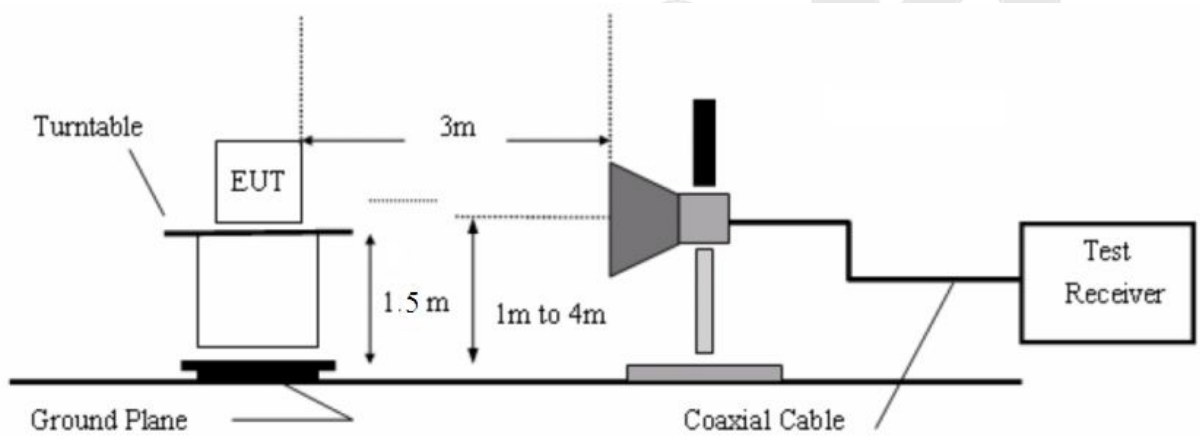

4.4 Test Results

PASS.

The EUT was tested on (Charging to adapter, On) modes, only the worst data of (On) are attached in the following pages.

Job No.:	011504034I	Polarization:	Horizontal
Standard:	(RE)FCC PART 15C_3m	Power Source:	DC 3.7V
Test item:	Radiation Test (30~1000MHz)	Temp.(C)/Hum.(%RH):	24.3( C)/55%RH
Test Mode:	On	Distance:	3m

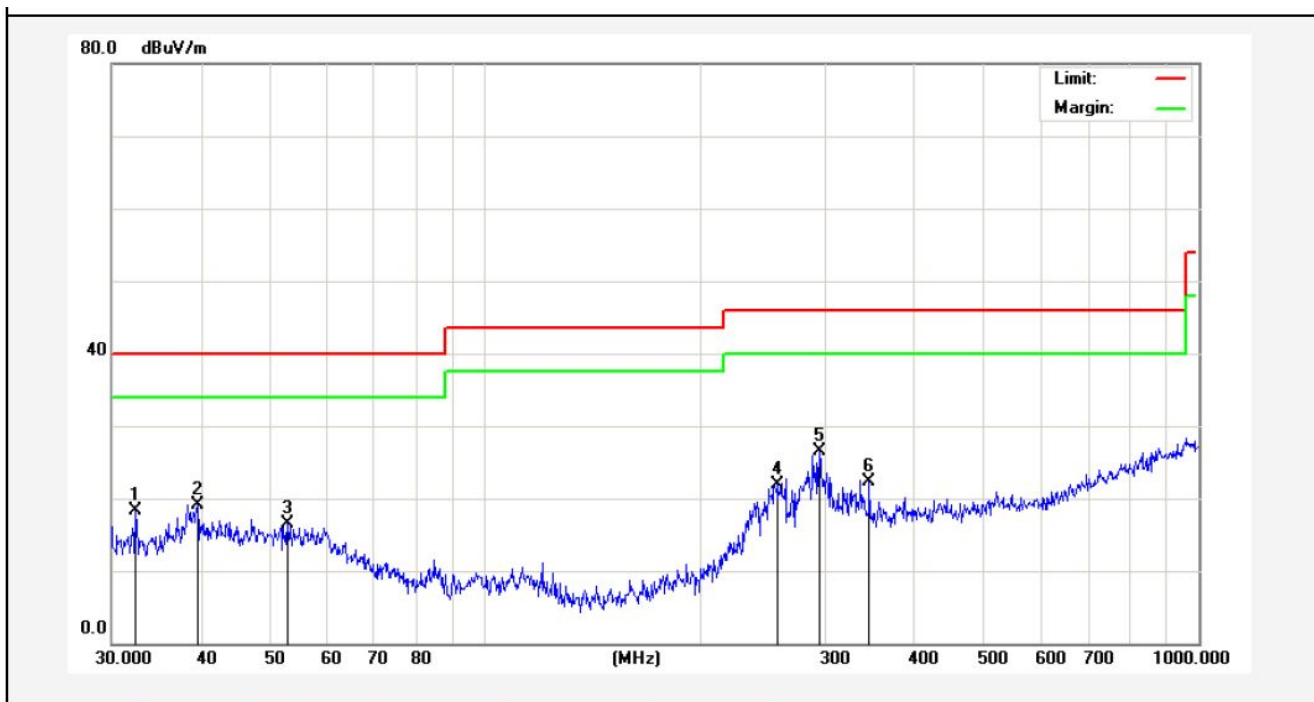

No.	Freq. (MHz)	Reading (dBuV/m)	Factor (dB/m)	Result (dBuV/m)	Limit (dBuV/)	Over Limit (dB)	Detector	Height (cm)	degree (deg)	Remark
1	32.4059	35.02	-16.63	18.39	40.00	-21.61	peak			
2	39.5757	33.62	-14.53	19.09	40.00	-20.91	peak			
3	52.9453	31.22	-14.78	16.44	40.00	-23.56	peak			
4	256.5211	40.75	-18.84	21.91	46.00	-24.09	peak			
5	294.1137	44.30	-17.84	26.46	46.00	-19.54	peak			
6	345.5952	36.35	-14.13	22.22	46.00	-23.78	peak			

Job No.:	011504034I	Polarization:	Vertical
Standard:	(RE)FCC PART 15C_3m	Power Source:	DC 3.7V
Test item:	Radiation Test (30~1000MHz)	Temp.(C)/Hum.(%RH):	24.3( C)/55%RH
Test Mode:	On	Distance:	3m

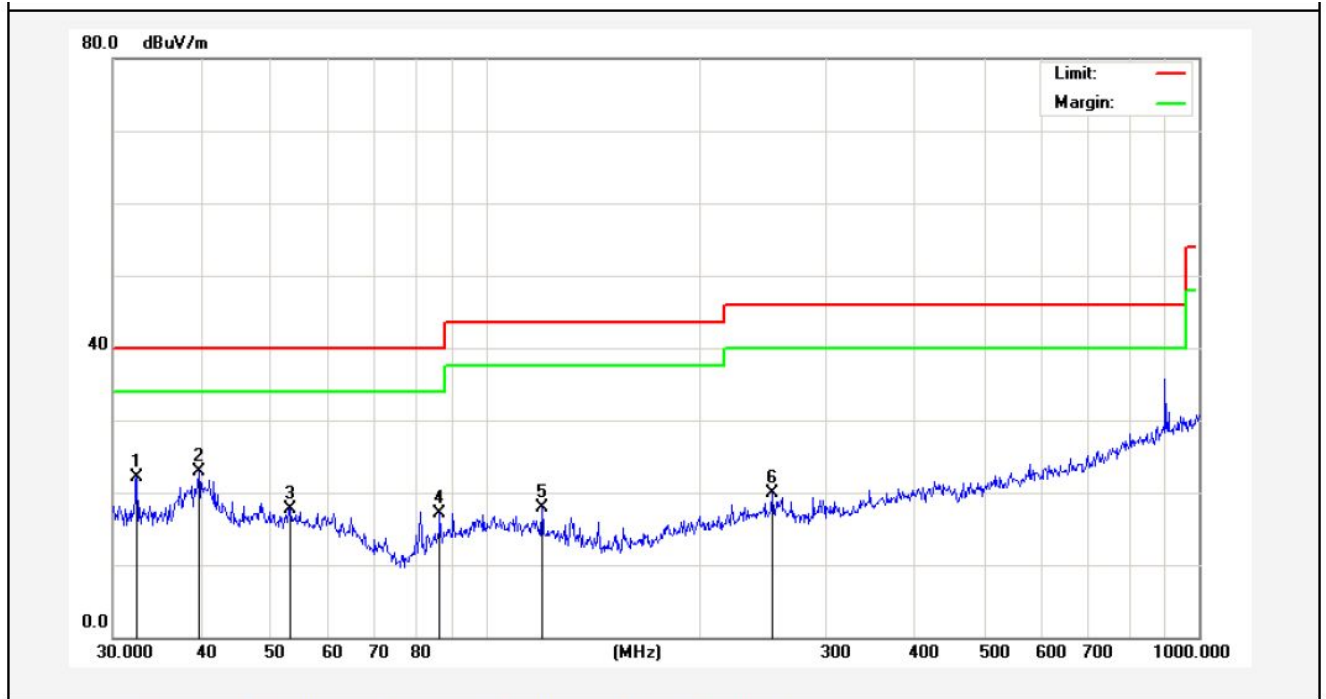

No.	Freq. (MHz)	Reading (dBuV/m)	Factor (dB/m)	Result (dBuV/m)	Limit (dBuV/)	Over Limit (dB)	Detector	Height (cm)	degree (deg)	Remark
1	32.4059	38.80	-16.63	22.17	40.00	-17.83	peak			
2	39.5757	37.43	-14.53	22.90	40.00	-17.10	peak			
3	53.1313	32.52	-14.79	17.73	40.00	-22.27	peak			
4	86.2001	35.36	-18.23	17.13	40.00	-22.87	peak			
5	119.8556	34.24	-16.32	17.92	43.50	-25.58	peak			
6	252.0627	33.84	-14.03	19.81	46.00	-26.19	peak			



Job No.:	011504034I	Polarization:	Horizontal
Standard:	(RE)FCC PART 15C_Class B_3m	Power Source:	DC 3.7V
Test item:	Radiation Test (Above 1GHz)	Temp.(C)/Hum.(%RH):	24.3( C)/55%RH
Test Mode:	TX(2402 MHz)	Distance:	3m

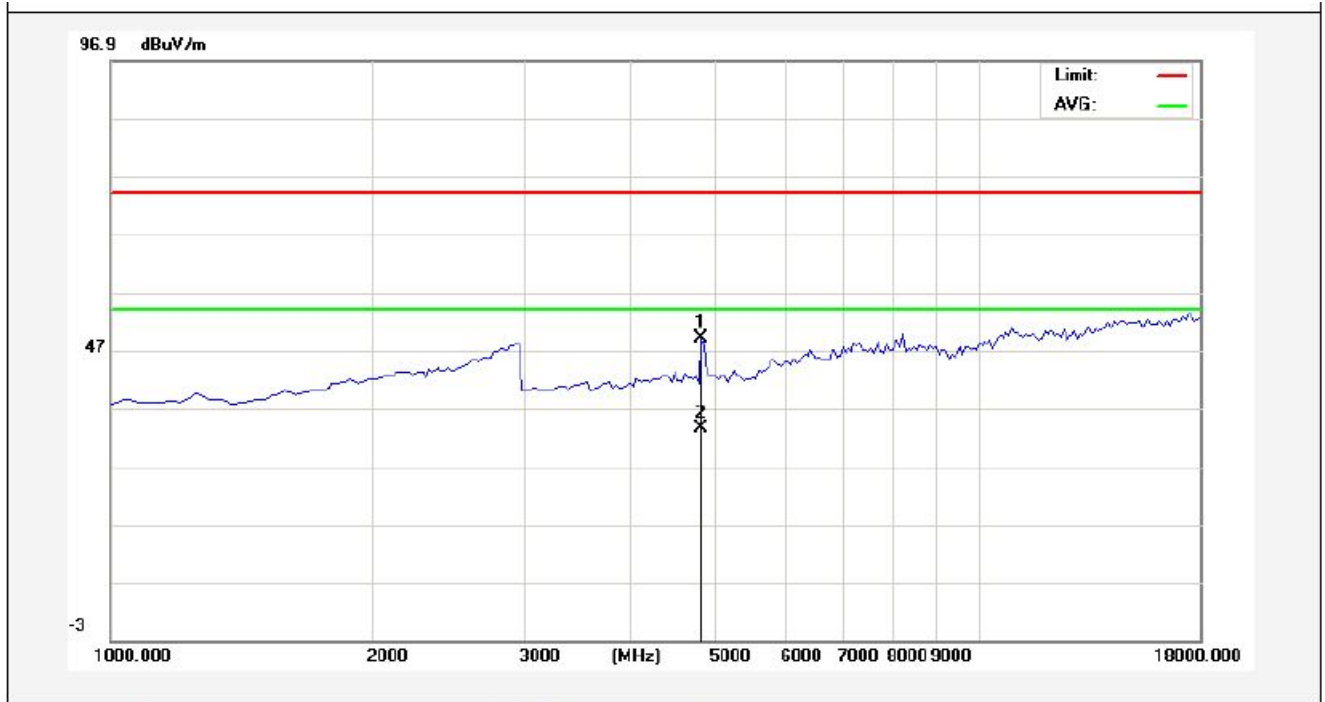

No.	Freq. (MHz)	Reading (dBuV/m)	Factor (dB/m)	Result (dBuV/m)	Limit (dBuV/)	Over Limit (dB)	Detector	Height (cm)	degree (deg)	Remark
1	4825.000	45.64	3.34	48.98	74.00	-25.02	peak			
2	4825.000	30.22	3.34	33.56	54.00	-20.44	AVG			

A.M.P.

Job No.:	011504034I	Polarization:	Vertical
Standard:	(RE)FCC PART 15C_Class B_3m	Power Source:	DC 3.7V
Test item:	Radiation Test (Above 1GHz)	Temp.(C)/Hum.(%RH):	24.3( C)/55%RH
Test Mode:	TX(2402 MHz)	Distance:	3m

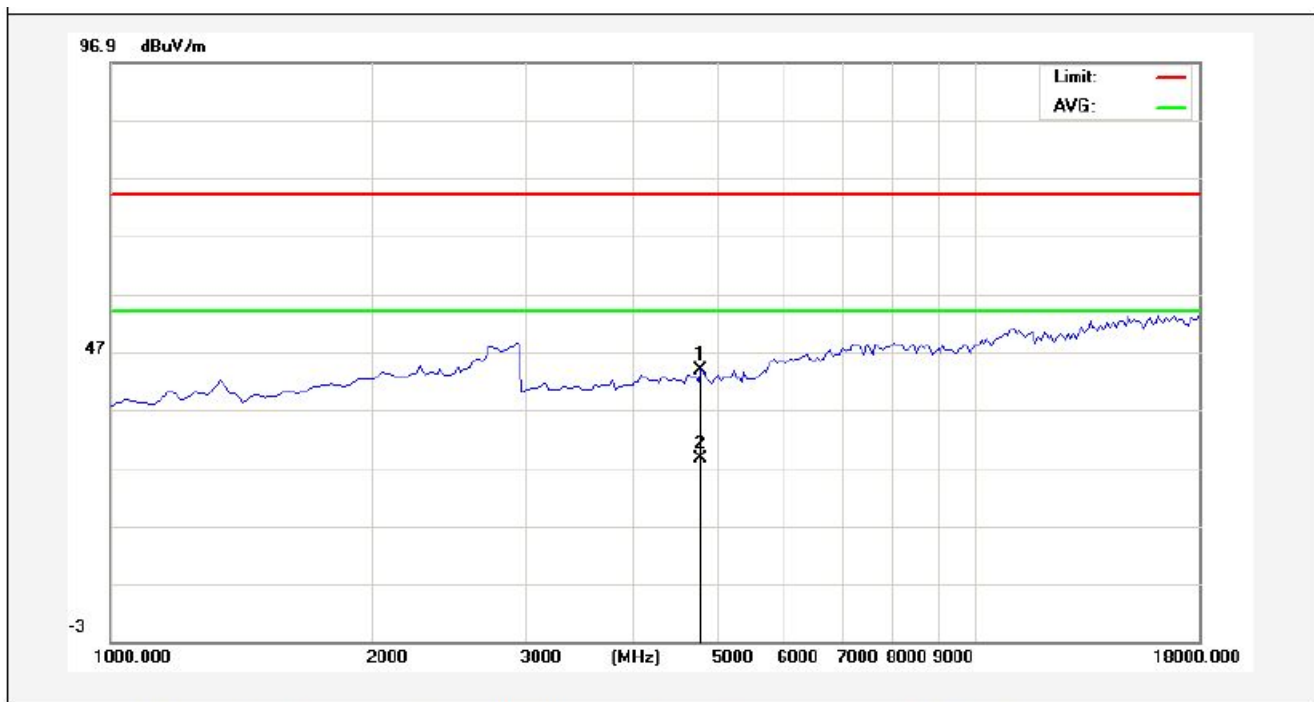

No.	Freq. (MHz)	Reading (dBuV/m)	Factor (dB/m)	Result (dBuV/m)	Limit (dBuV/)	Over Limit (dB)	Detector	Height (cm)	degree (deg)	Remark
1	4825.000	40.50	3.34	43.84	74.00	-30.16	peak			
2	4825.000	25.11	3.34	28.45	54.00	-25.55	AVG			

AMT

Job No.:	011504034I	Polarization:	Horizontal
Standard:	(RE)FCC PART 15C_Class B_3m	Power Source:	DC 3.7V
Test item:	Radiation Test (Above 1GHz)	Temp.(C)/Hum.(%RH):	24.3( C)/55%RH
Test Mode:	TX(2441 MHz)	Distance:	3m

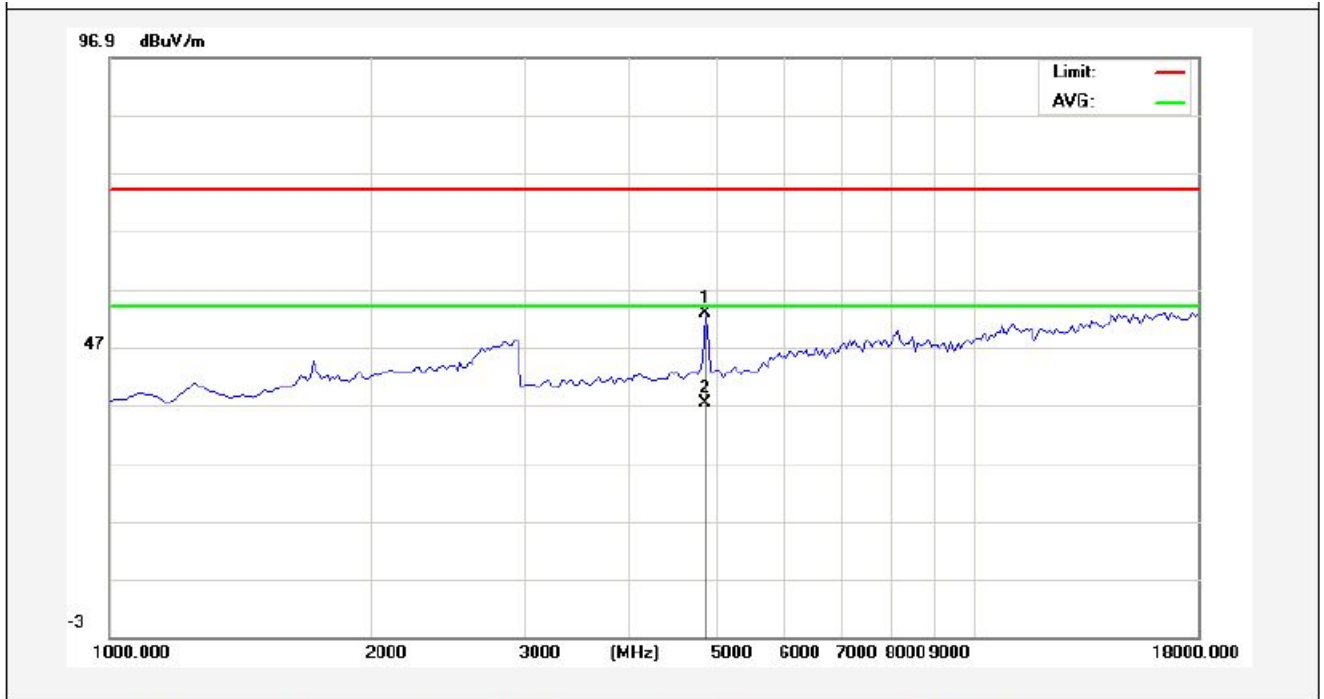

No.	Freq. (MHz)	Reading (dBuV/m)	Factor (dB/m)	Result (dBuV/m)	Limit (dBuV/)	Over Limit (dB)	Detector	Height (cm)	degree (deg)	Remark
1	4867.500	49.41	3.41	52.82	74.00	-21.18	peak			
2	4867.500	33.83	3.41	37.24	54.00	-16.76	AVG			

Job No.:	011504034I	Polarization:	Vertical
Standard:	(RE)FCC PART 15C_Class B_3m	Power Source:	DC 3.7V
Test item:	Radiation Test (Above 1GHz)	Temp.(C)/Hum.(%RH):	24.3( C)/55%RH
Test Mode:	TX(2441 MHz)	Distance:	3m

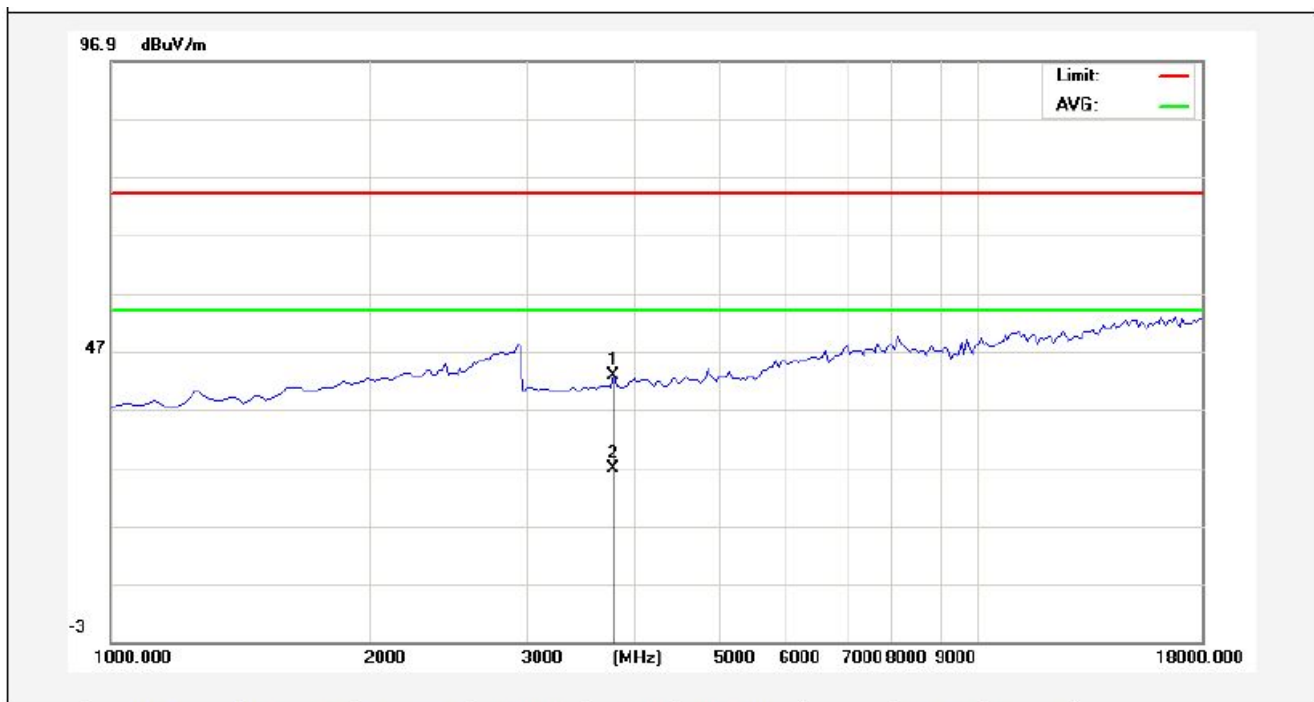

No.	Freq. (MHz)	Reading (dBuV/m)	Factor (dB/m)	Result (dBuV/m)	Limit (dBuV/)	Over Limit (dB)	Detector	Height (cm)	degree (deg)	Remark
1	3805.000	41.14	1.59	42.73	74.00	-31.27	peak			
2	3805.000	25.24	1.59	26.83	54.00	-27.17	AVG			

Job No.:	011504034I	Polarization:	Horizontal
Standard:	(RE)FCC PART 15C_Class B_3m	Power Source:	DC 3.7V
Test item:	Radiation Test (Above 1GHz)	Temp.(C)/Hum.(%RH):	24.3( C)/55%RH
Test Mode:	TX(2480 MHz)	Distance:	3m

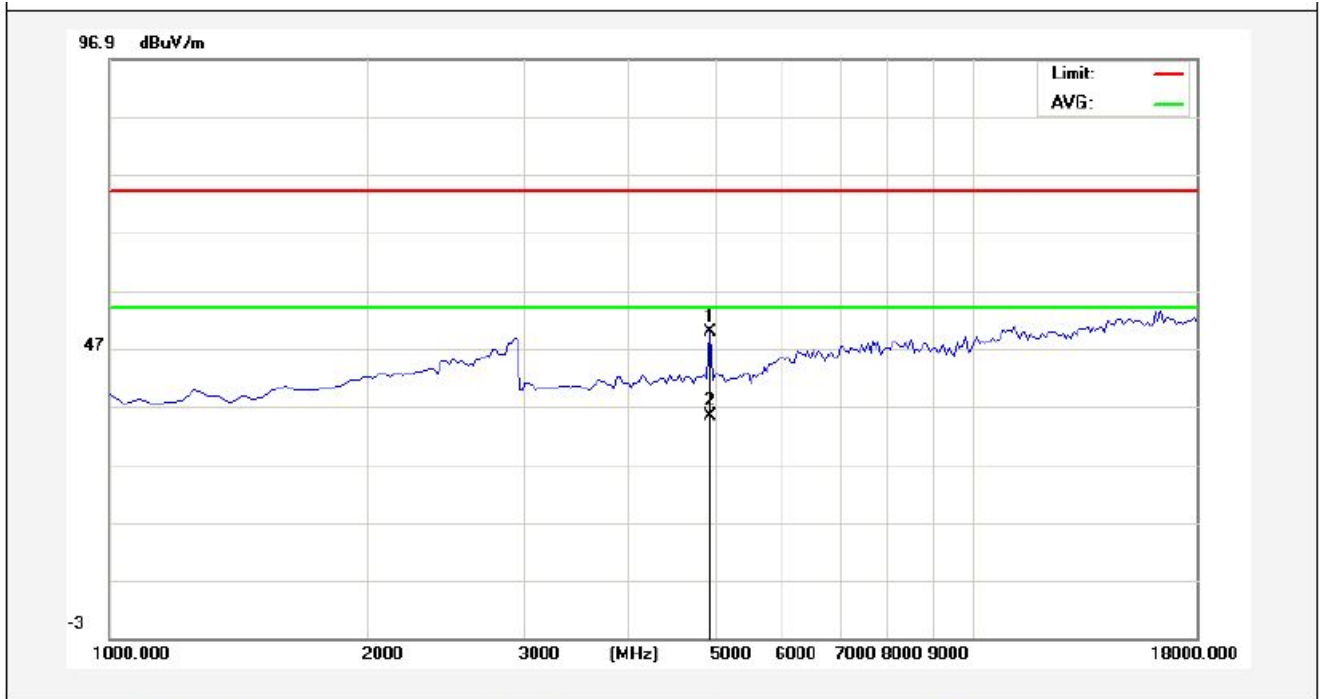

No.	Freq. (MHz)	Reading (dBuV/m)	Factor (dB/m)	Result (dBuV/m)	Limit (dBuV/)	Over Limit (dB)	Detector	Height (cm)	degree (deg)	Remark
1	4952.500	46.23	3.57	49.80	74.00	-24.20	peak			
2	4952.500	31.66	3.57	35.23	54.00	-18.77	AVG			

Job No.:	011504034I	Polarization:	Vertical
Standard:	(RE)FCC PART 15C_Class B_3m	Power Source:	DC 3.7V
Test item:	Radiation Test (Above 1GHz)	Temp.(C)/Hum.(%RH):	24.3( C)/55%RH
Test Mode:	TX(2480 MHz)	Distance:	3m

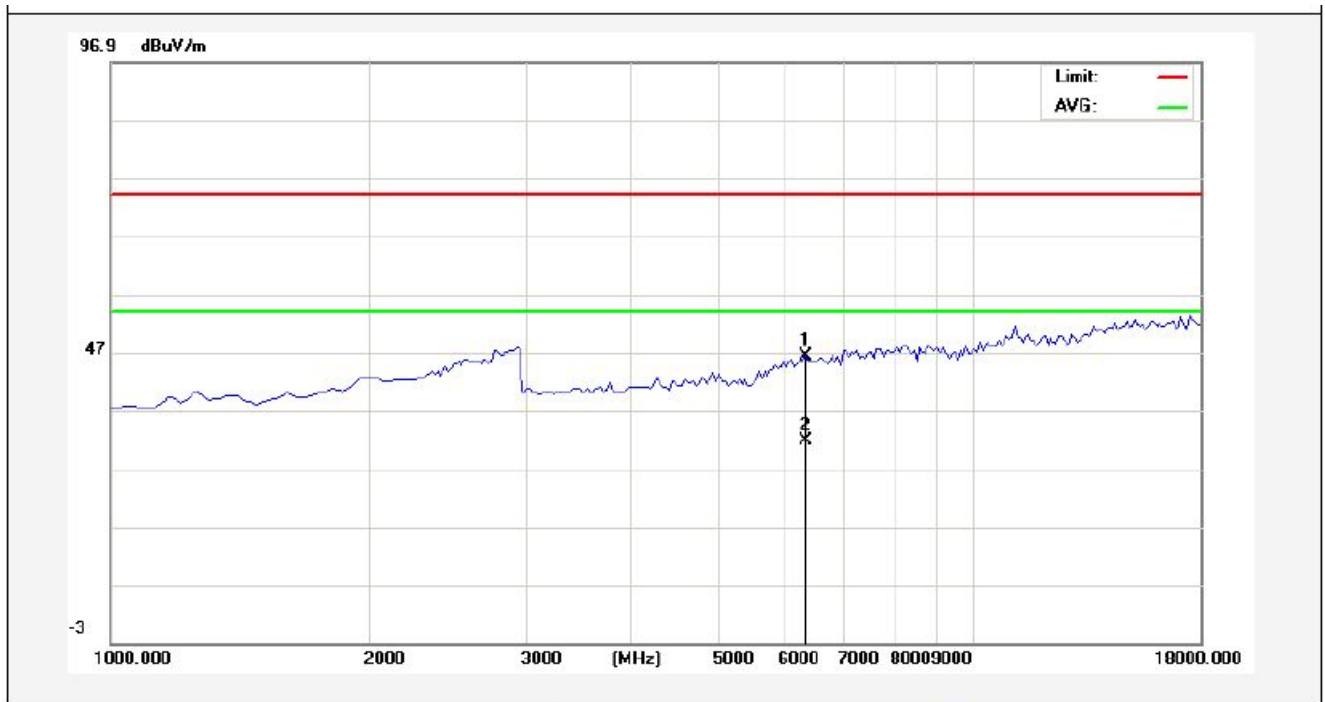

No.	Freq. (MHz)	Reading (dBuV/m)	Factor (dB/m)	Result (dBuV/m)	Limit (dBuV/)	Over Limit (dB)	Detector	Height (cm)	degree (deg)	Remark
1	6355.000	38.94	7.46	46.40	74.00	-27.60	peak			
2	6355.000	24.39	7.46	31.85	54.00	-22.15	AVG			

A M

## 5. CHANNEL SEPARATION TEST

### 5.1 Measurement Procedure

The EUT must have its hopping function enabled. Using the following spectrum analyzer settings:

1. Span= Wide enough to capture the peaks of two adjacent channels
2. Set the RBW = 30 kHz.
3. Set the VBW = 100 kHz.
4. Sweep time = auto couple.
5. Detector function = peak.
6. Trace mode = max hold.
7. Allow trace to fully stabilize.

### 5.2 Test SET-UP

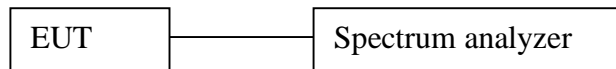

### 5.3 Test Equipment

Item	Equipment	Manufacturer	Model No.	Serial No.	Last Cal.	Cal. Interval
1.	Spectrum Analysis	Agilent	E4407B	US39390582	Aug. 08, 2014	1 Year
2.	Preamplifier	Instruments corporation	EMC011830	980100	Aug. 08, 2014	1 Year
3.	EMI Test Receiver	Rohde & Schwarz	ESPI	101604	Apr. 22, 2014	1 Year
4.	Double Ridged Horn Antenna	Instruments corporation	GTH-0118	351600	Apr. 22, 2014	1 Year
5.	Bilog Broadband Antenna	Schwarzbeck	VULB9163	VULB 9163-289	Apr. 24, 2014	1 Year
6.	Pre-amplifier	SONOMA	310N	186860	Aug. 08, 2014	1 Year
7.	EMI Test Software EZ-EMC	SHURPLE	N/A	N/A	N/A	N/A

### 5.4 Test Results

Test Item	: Frequency Separation	Test Mode	: CH Low ~ CH High
Test Voltage	: DC 3.7V	Temperature	: 24°C
Test Result	: PASS	Humidity	: 55%RH

Channel	Frequency (MHz)	Separation Read Value (kHz)	Limit (kHz)	Modulation Mode
Low	2401	1008	880	BDR
Mid	2441	1002	880	BDR
High	2480	1002	880	BDR
Low	2401	1002	806	EDR
Mid	2441	1002	806	EDR
High	2480	1002	806	EDR

Remark:

- The limit of mode (EDR) is 2/3 of 20dB BW;

Mode: BDR

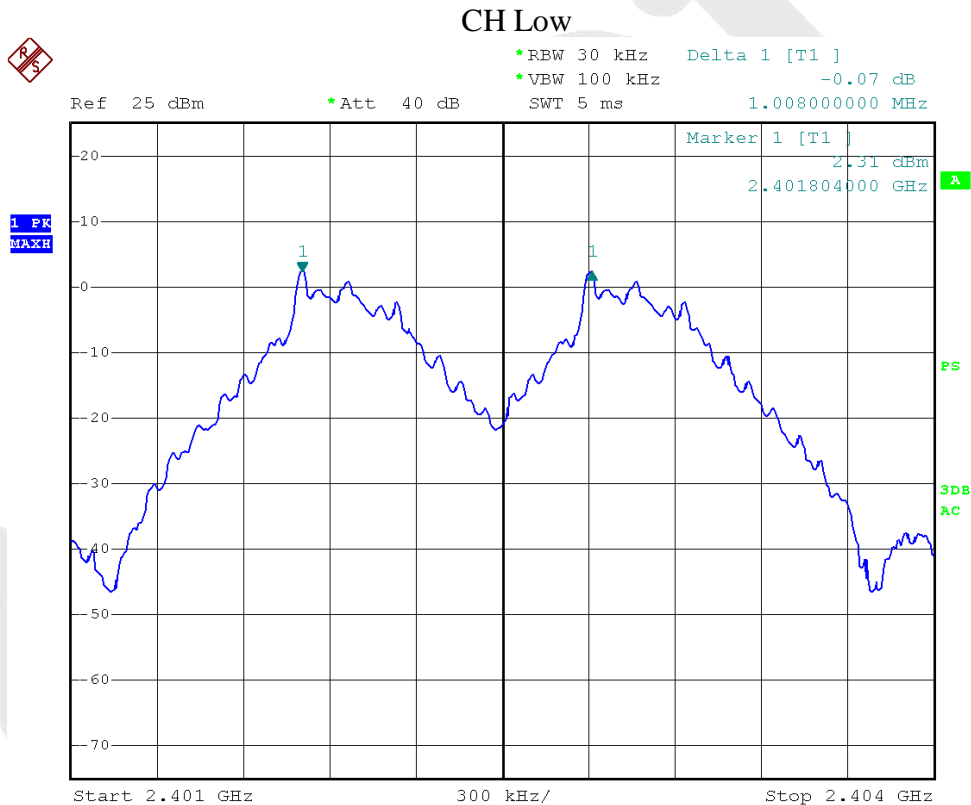



CH Mid

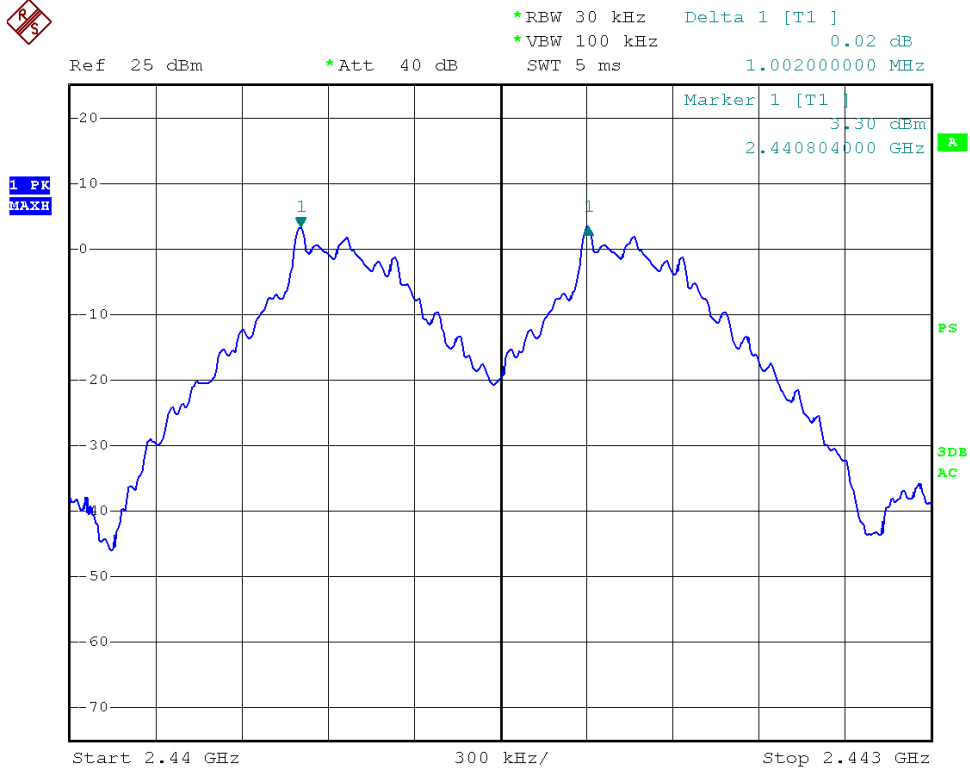

CH High

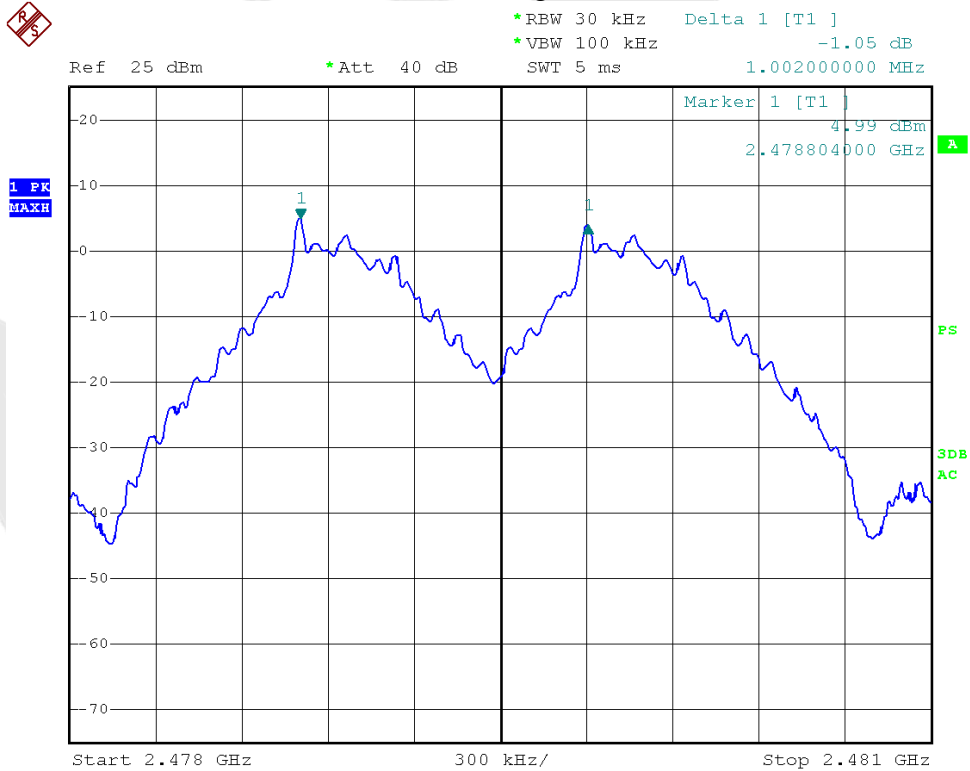

Mode: EDR

CH Low

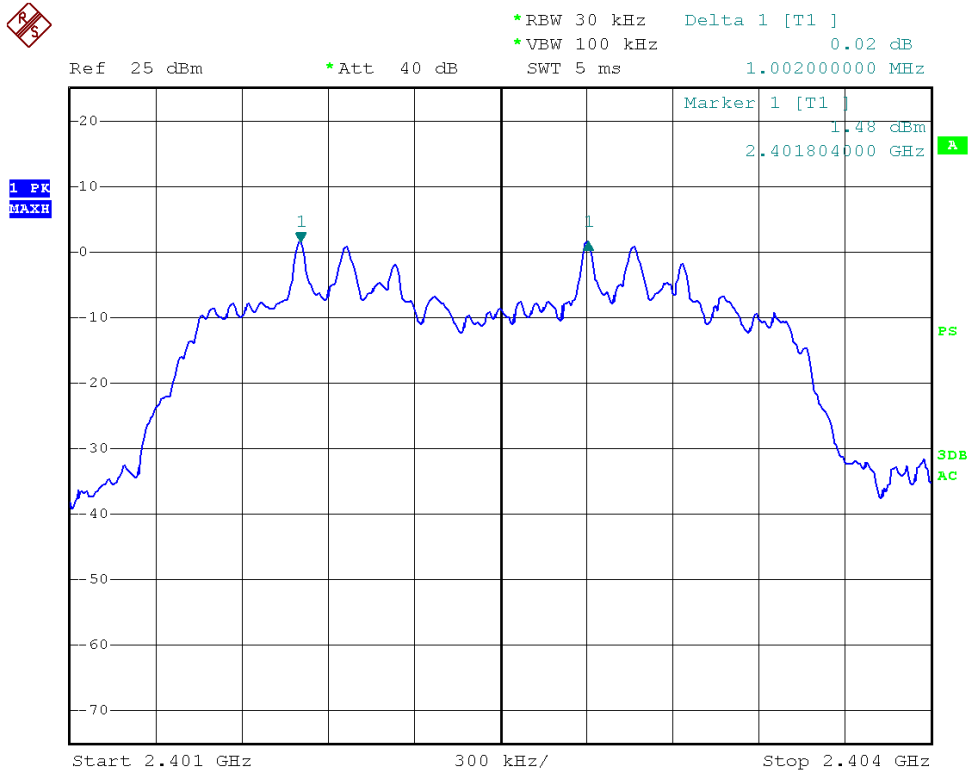

CH Mid

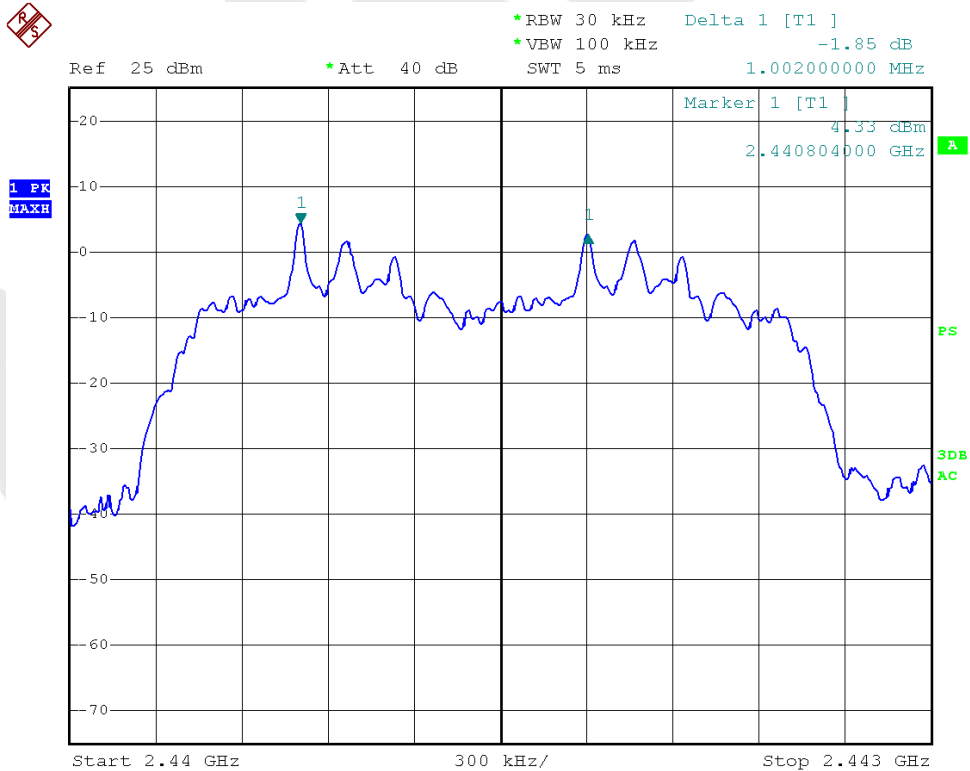

CH High

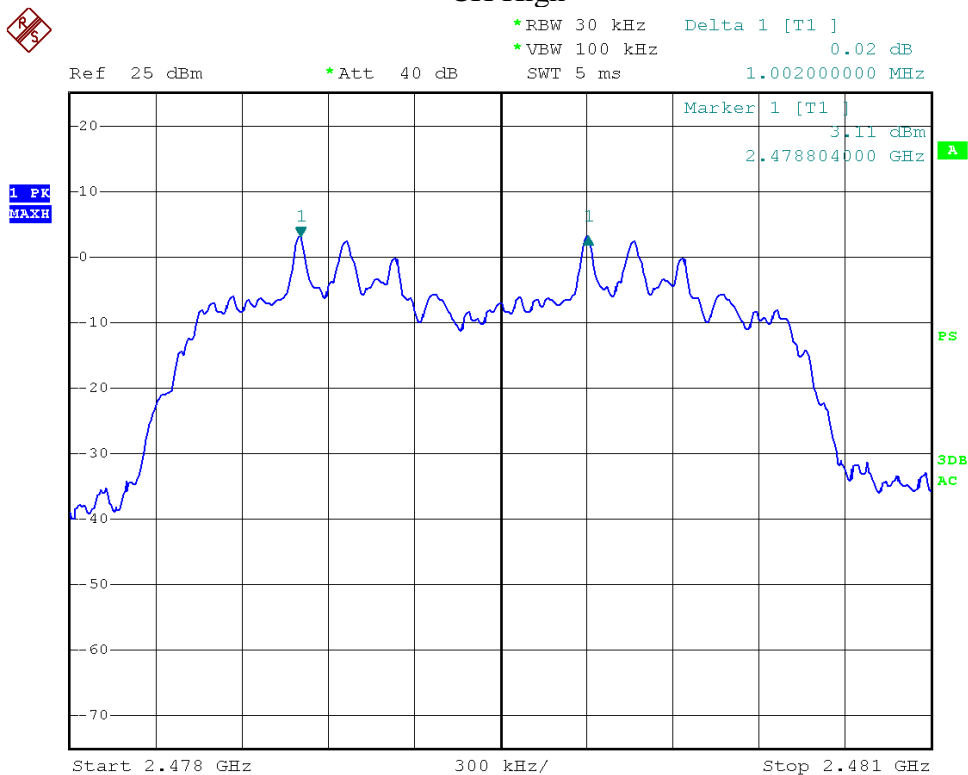

Anbotek

## 6. 20DB BANDWIDTH TEST

### 6.1 Measurement Procedure

Using the following spectrum analyzer settings:

1. Span= approximately 2 to 3 times the 20dB bandwidth, centered on a hopping channel.
2. Set the RBW = 30 kHz.
3. Set the VBW = 100 kHz.
4. Sweep time = auto couple.
5. Detector function = peak.
6. Trace mode = max hold.
7. Allow trace to fully stabilize.

### 6.2 Test SET-UP

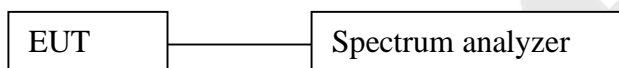

### 6.3 Test Equipment

Same as the equipment listed in 5.3.

### 6.4 Test Results

Test Item	: 20dB BW	Test Mode	: CH Low ~ CH High
Test Voltage	: DC 3.7V	Temperature	: 24°C
Test Result	: PASS	Humidity	: 55%RH

Channel	Frequency (MHz)	20dB Down BW(kHz)	Modulation Mode
Low	2401	880	BDR
Mid	2441	880	BDR
High	2480	880	BDR
Low	2401	1220	EDR
Mid	2441	1220	EDR
High	2480	1220	EDR

Mode: BDR

CH Low

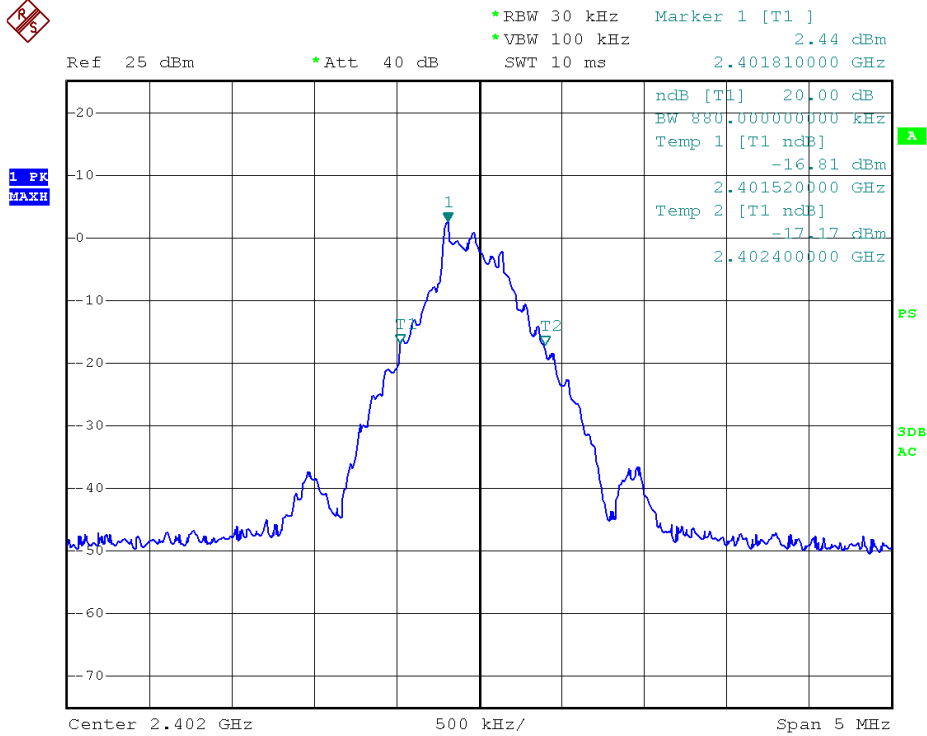

CH Middle

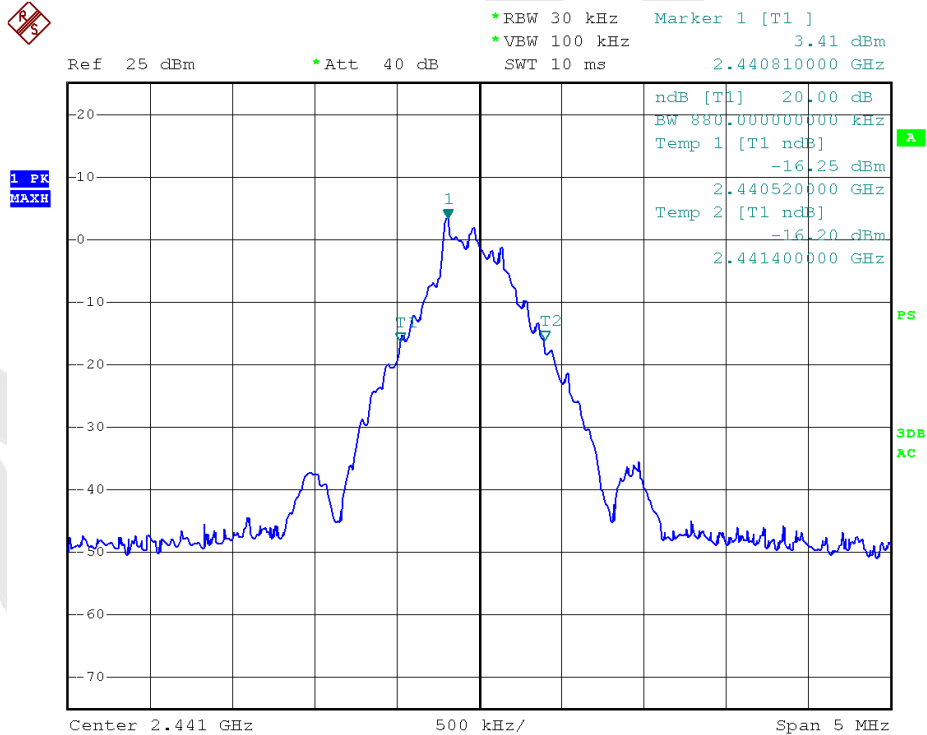

CH High

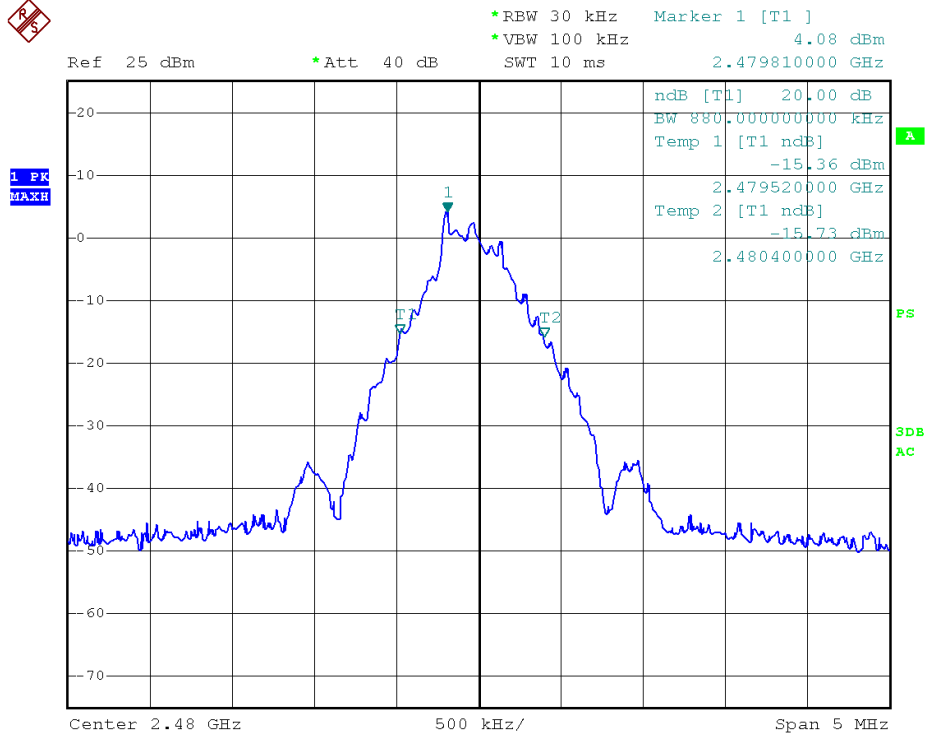

Mode: EDR

CH Low

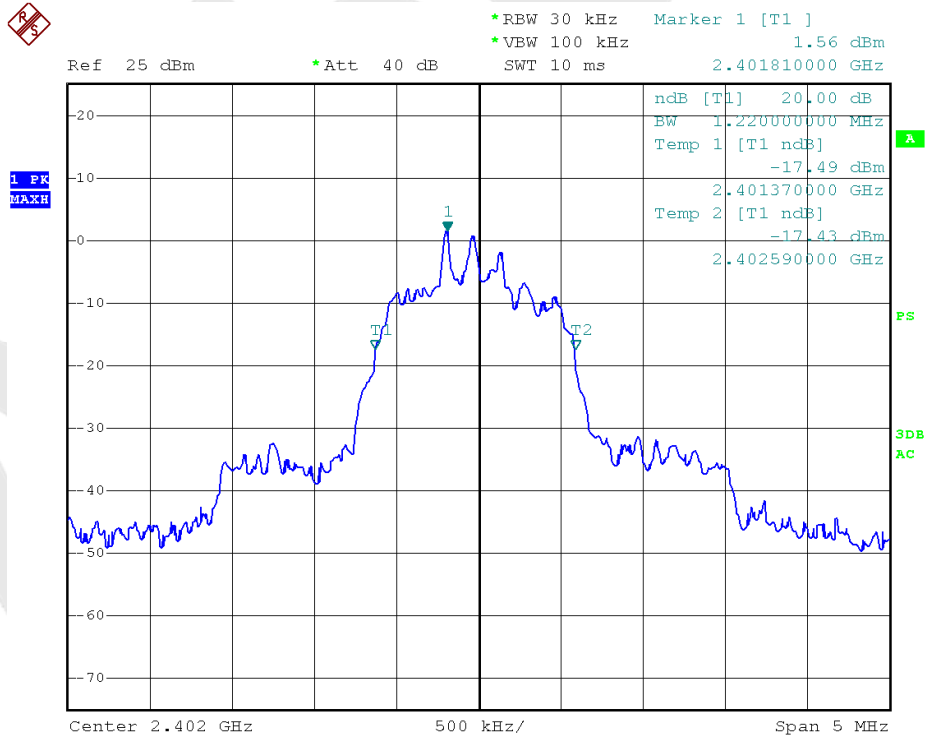

CH Middle

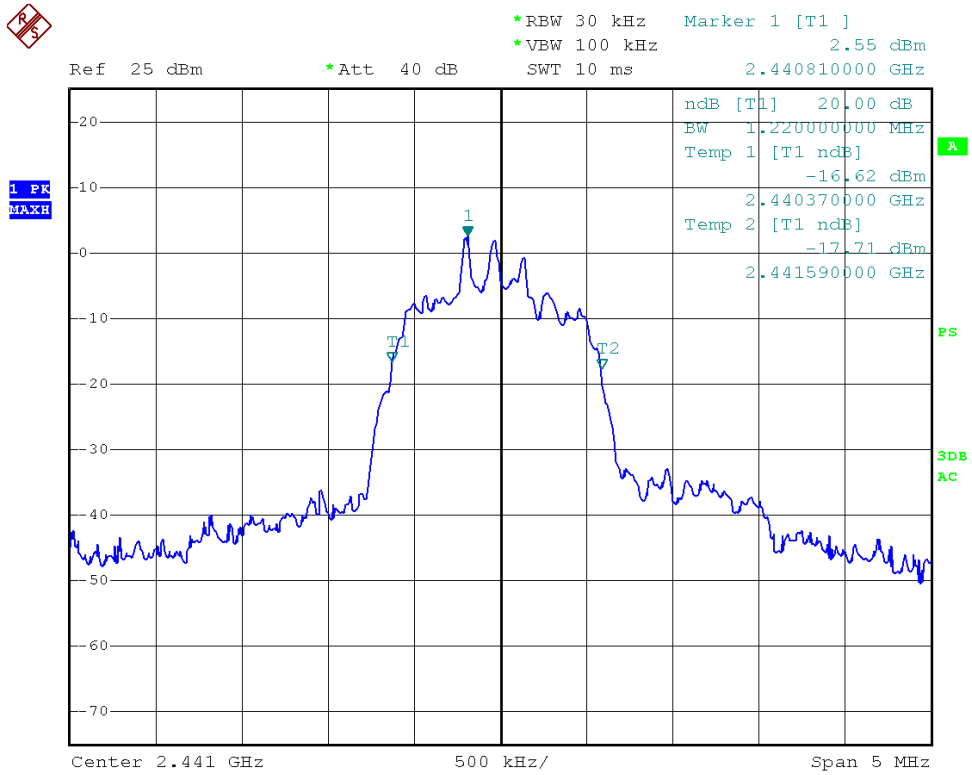

CH High

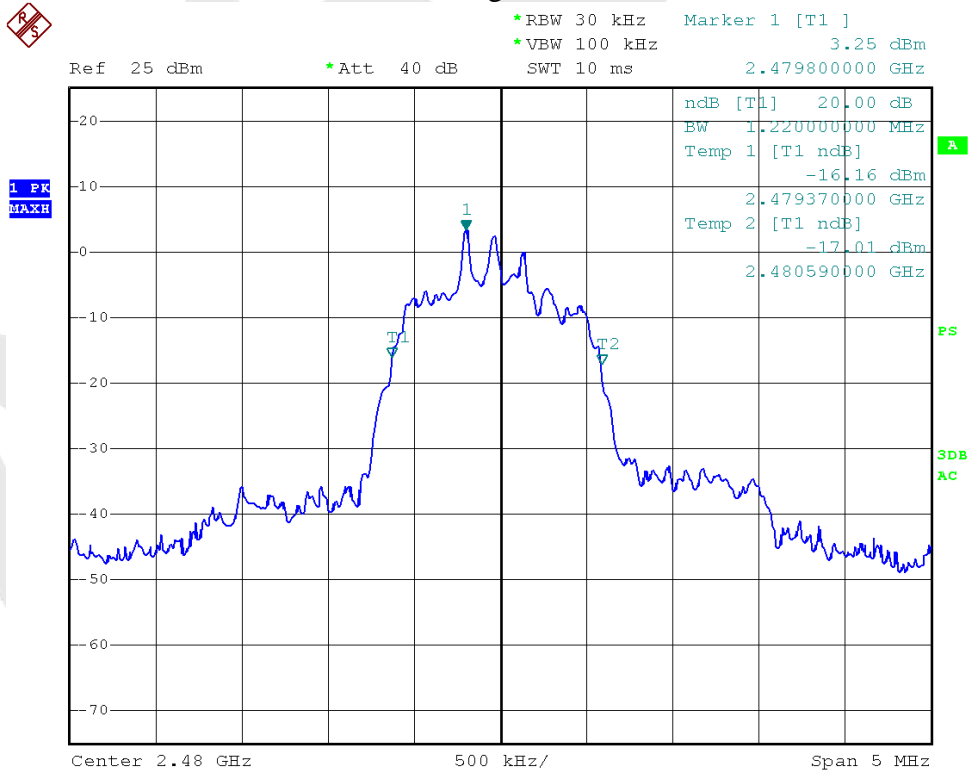

## 7. QUANTITY OF HOPPING CHANNEL TEST

### 7.1 Measurement Procedure

The EUT must have its hopping function enabled. Using the following spectrum analyzer setting:

1. Span= the frequency band of operation
2. Set the RBW = 1 MHz.
3. Set the VBW = 1 MHz.
4. Sweep time = auto couple.
5. Detector function = peak.
6. Trace mode = max hold.
7. Allow trace to fully stabilize.

### 7.2 Test SET-UP

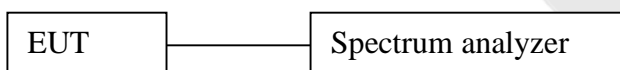

### 7.3 Test Equipment

Same as the equipment listed in 5.3.

### 7.4 Test Results

Test Item	: Number of Hopping Frequency	Test Mode	: CH Low ~ CH High
Test Voltage	: DC 3.7V	Temperature	: 24°C
Test Result	: PASS	Humidity	: 55%RH

Hopping Channel Frequency Range	Quantity of Hopping Channel	Quantity of Hopping Channel
2402-2480	79	> 15



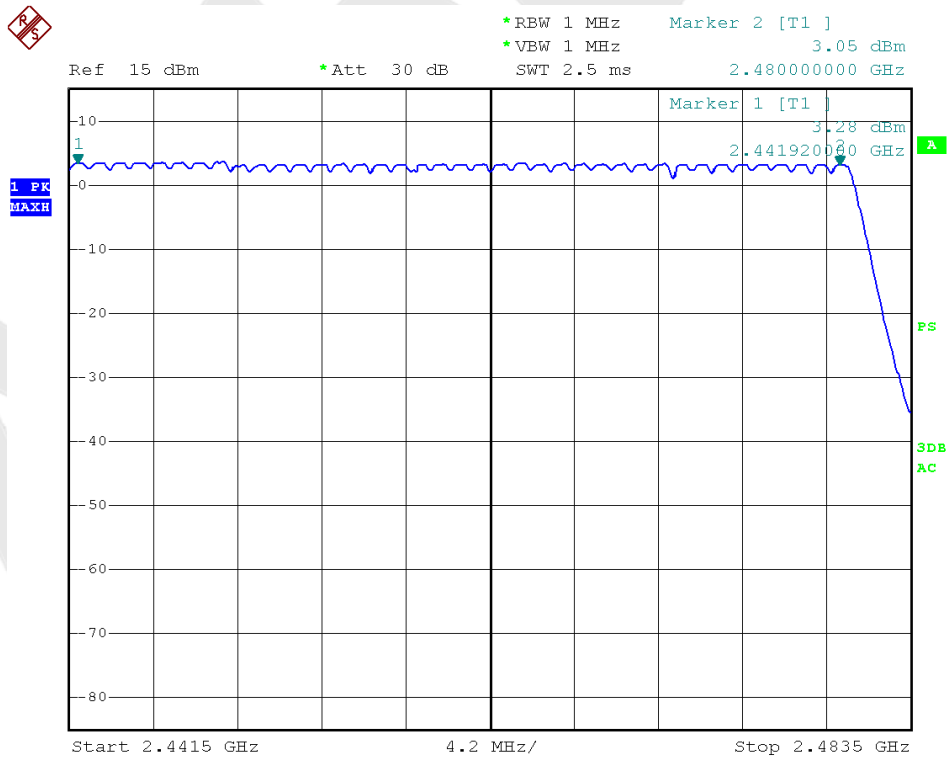
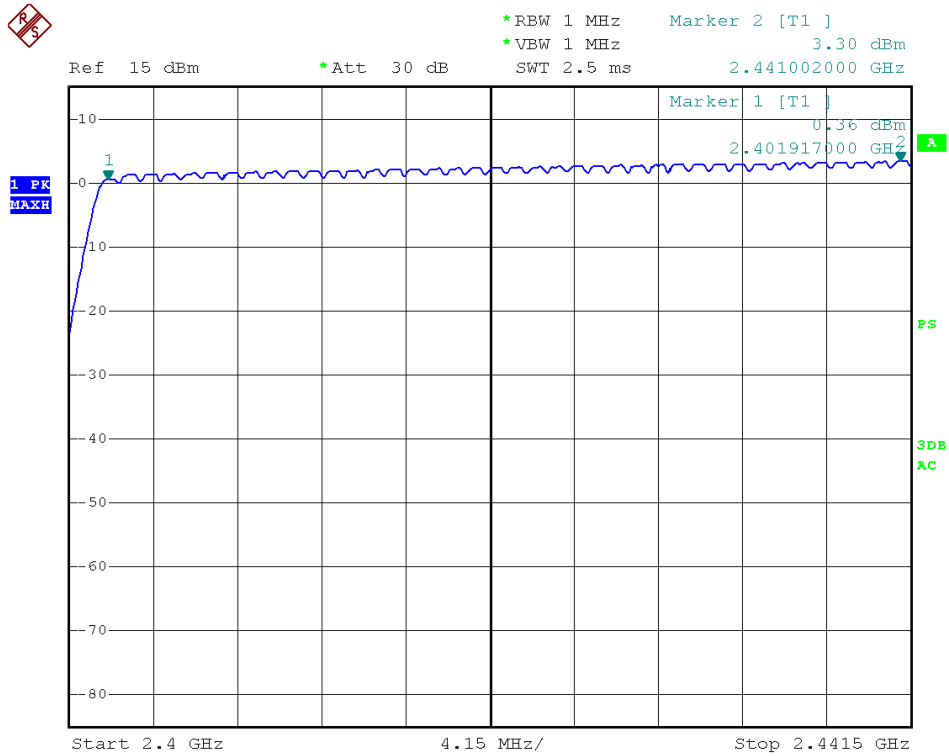

## 8. DWELL TIME TEST

### 8.1 Measurement Procedure

The EUT must have its hopping function enabled. Use the following spectrum analyzer settings:

1. Span= zero span, centered on a hopping channel
2. Set the RBW = 1 MHz.
3. Set the VBW = 1 MHz.
4. Sweep time = as necessary to capture the entire dwell time per hopping channel.
5. Detector function = peak.
6. Trace mode = max hold.
7. Allow trace to fully stabilize.

### 8.2 Test SET-UP

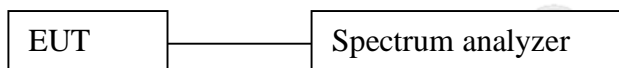

### 8.3 Test Equipment

Same as the equipment listed in 5.3.

### 8.4 Test Results

Test Item	: Time of Occupancy	Test Mode	: CH Low ~ CH High
Test Voltage	: DC 3.7V	Temperature	: 24°C
Test Result	: PASS	Humidity	: 55%RH

Package Type	Pulse width (ms)	Time slot length(ms)	Dwell time (ms)	Limit (s)
DH1	0.428	time slot length *1600/2 /79 * 31.6	136.96	0.4
DH3	1.736	time slot length *1600/4 /79 * 31.6	277.76	0.4
DH5	2.996	time slot length *1600/6 /79 * 31.6	319.57	0.4

DH1

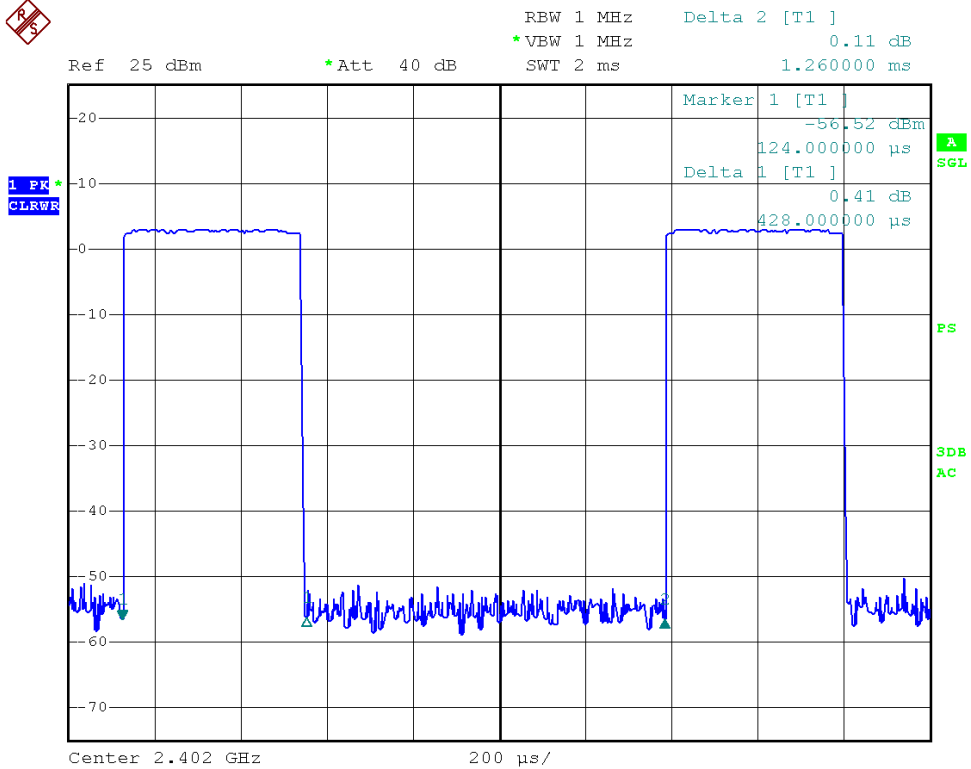

DH3

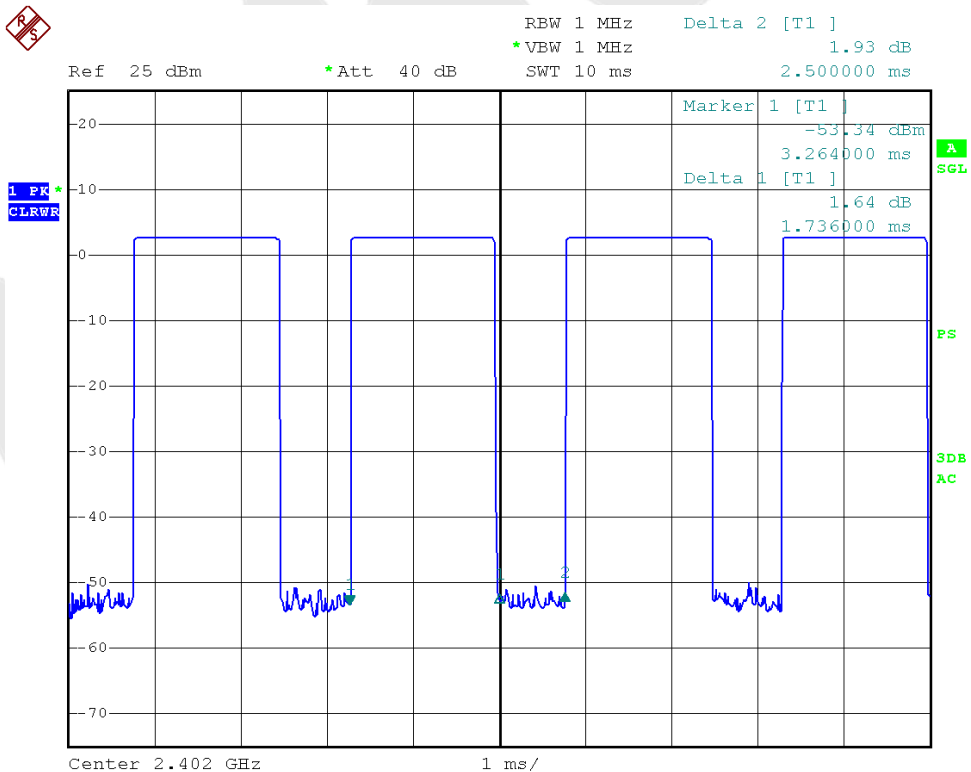

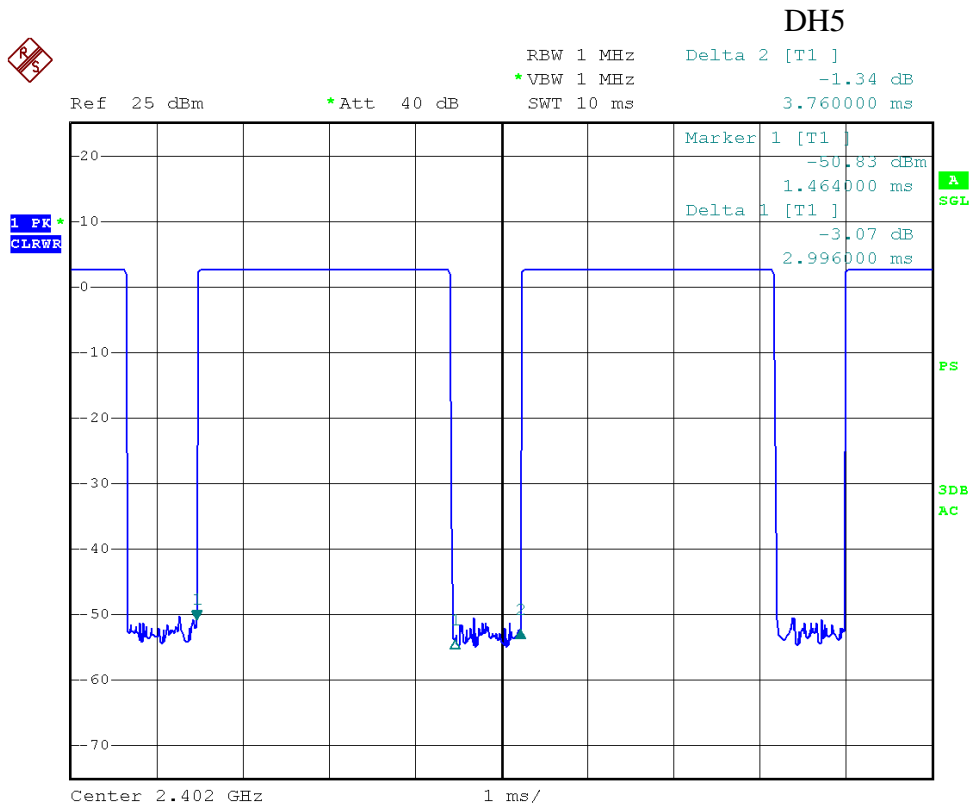

## 9. MAXIMUM PEAK OUTPUT POWER TEST

### 9.1 Measurement Procedure

- a. Check the calibration of the measuring instrument(SA) using either an internal calibrator or a known signal from an external generator.
- b. Turn on the EUT and connect it to measurement instrument. Then set it to any one convenient frequency within its operating range. Set a reference level on the measuring instrument equal to the highest peak value.
- c. The center frequency of the spectrum analyzer is set to the fundamental frequency and using proper RBW and VBW setting.
- d. Measure the captured power within the band and recording the plot.
- e. Repeat above procedures until all frequencies required were complete.

Using the following spectrum analyzer settings:

1. Span= approximately 5 times the 20dB bandwidth, centered on a hopping channel
2. Set the RBW = 3 MHz.
3. Set the VBW = 3 MHz.
4. Sweep time = auto couple.
5. Detector function = peak.
6. Trace mode = max hold.
7. Allow trace to fully stabilize.

### 9.2 Test SET-UP

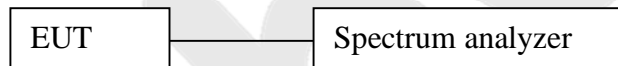

### 9.3 Test Equipment

Same as the equipment listed in 5.3.

### 9.4 Test Results

Test Item	: Max. peak output power	Test Mode	: CH Low ~ CH High
Test Voltage	: DC 3.7V	Temperature	: 24°C
Test Result	: PASS	Humidity	: 55%RH

Channel Frequency (MHz)	Peak Power output(mW)	Peak Power output(dBm)	Peak Power Limit(mW)	Results	Modulation
2402	1.26	0.98	1000	PASS	BDR
2441	1.34	1.27	1000	PASS	BDR
2480	<b>1.45</b>	<b>1.62</b>	1000	PASS	BDR
2402	0.28	-0.63	125	PASS	EDR
2441	0.54	-0.30	125	PASS	EDR
2480	1.02	0.07	125	PASS	EDR

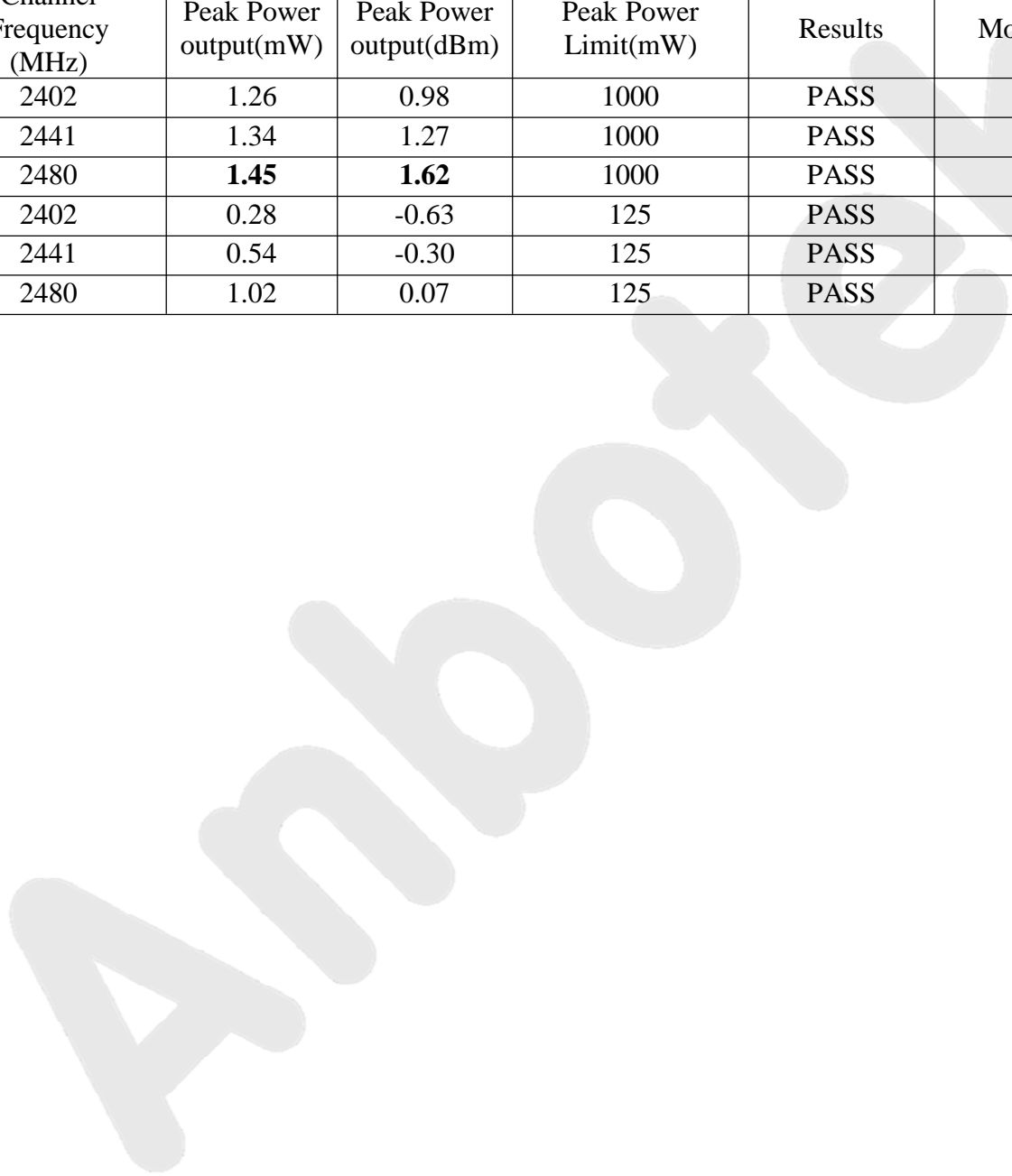

Mode: BDR

### CH Low

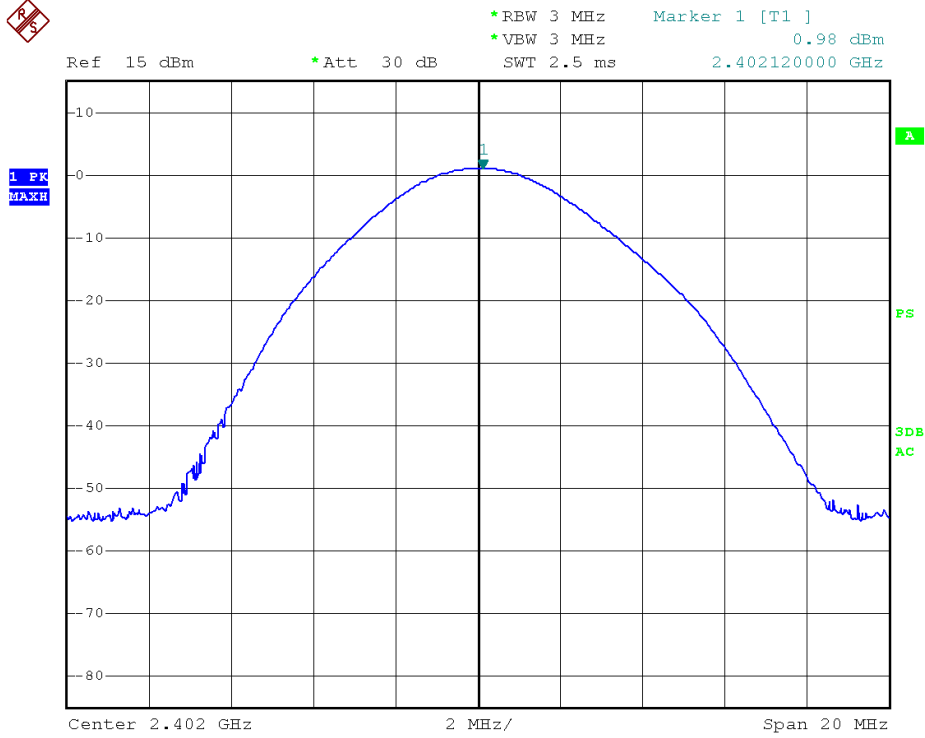

### CH Mid

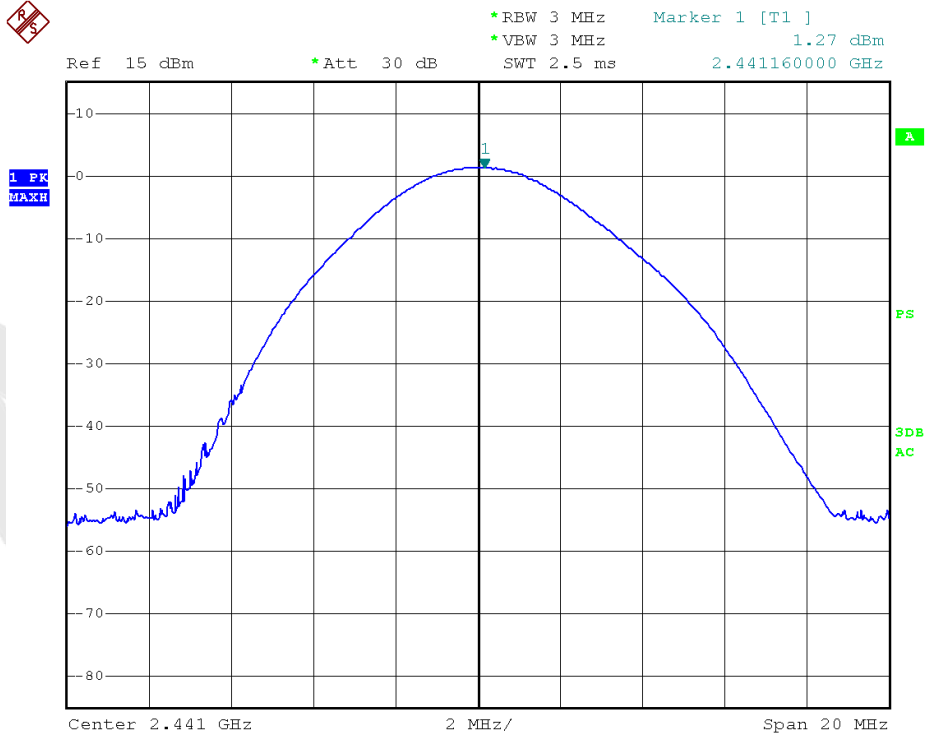

CH High

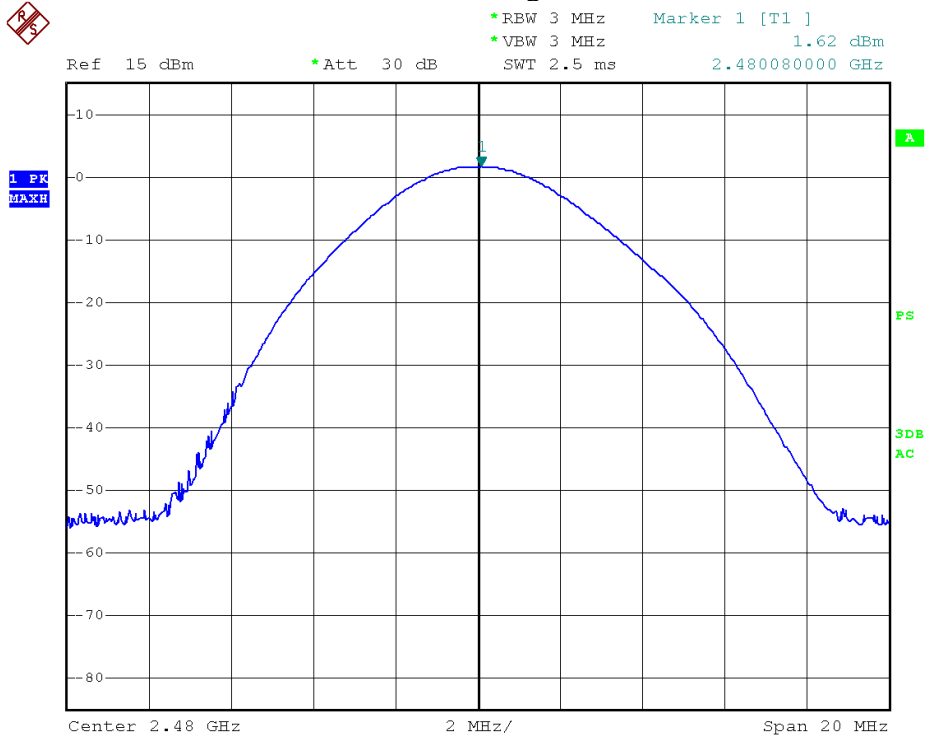

Mode: EDR

CH Low

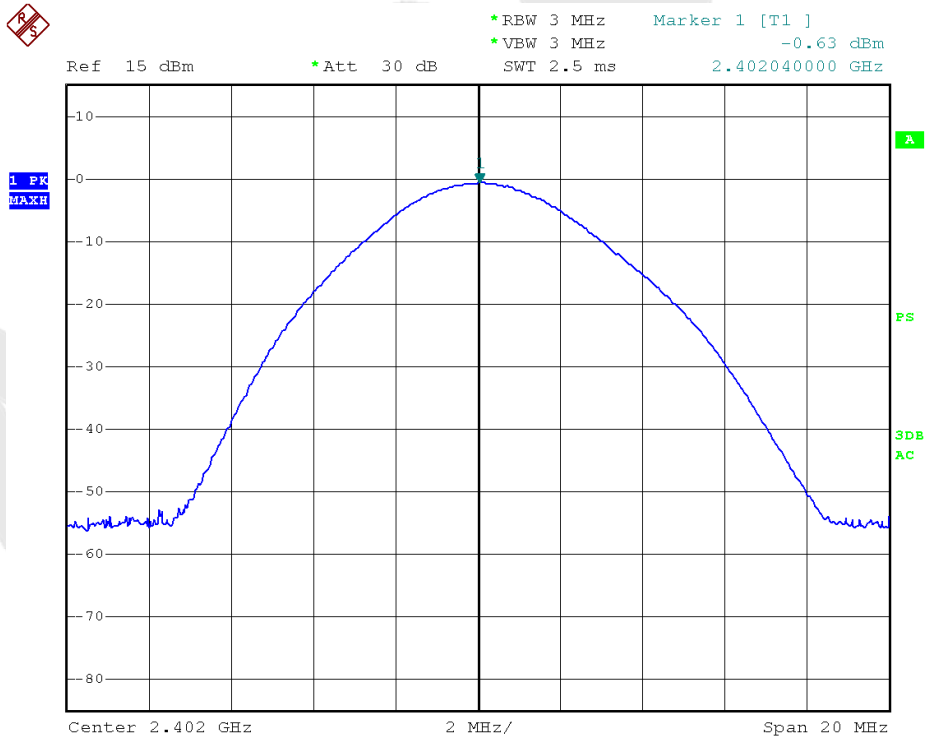



### CH Mid

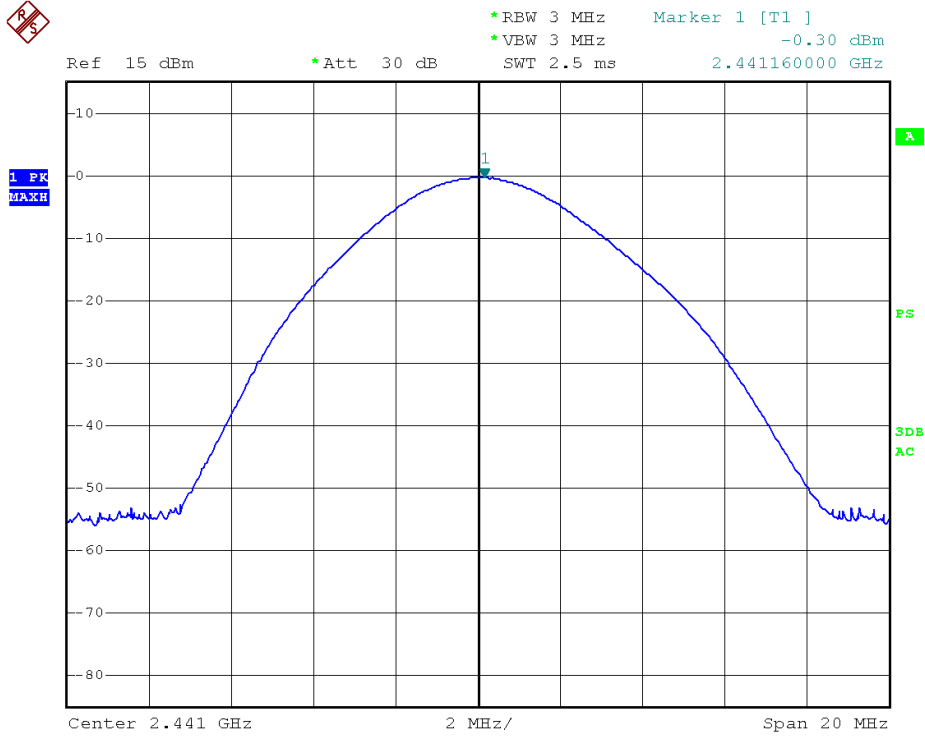

### CH High

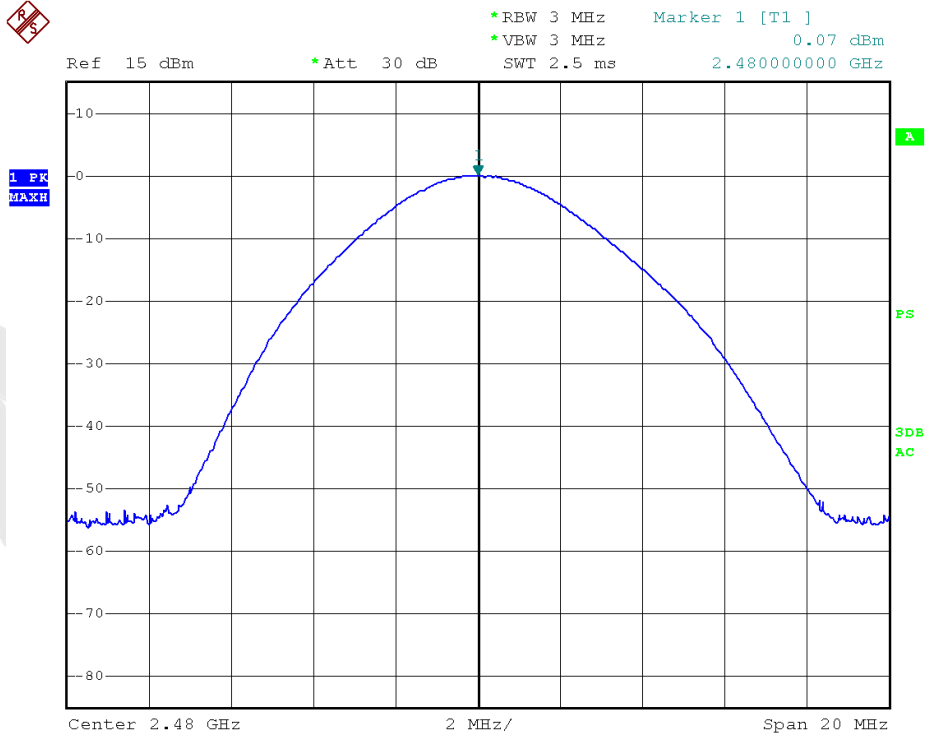

## 10. BAND EDGE TEST

### 10.1 Measurement Procedure

#### A) Conducted Emission method:

1. Check the calibration of the measuring instrument using either an internal calibrator or a known signal from an external generator.
2. Position the EUT without connection to measurement instrument. Put it on the Rotated table and turn on the EUT and make it operate in transmitting mode. Then set it to low Channel and High Channel within its operating range, and make sure the instrument is operated in its linear range.
3. Set both RBW and VBW of spectrum analyzer to 100kHz with a convenient frequency span including 100kHz bandwidth from band edge,
4. Measurement the highest amplitude appearing on spectral display and set it as a reference level. Plot the graph with marking the highest point and edge frequency.
5. Report above procedures until all measured frequencies were complete.

#### B) Radiated Emission method:

The EUT is placed on a turn table which is 1.5 meter high above the ground. The turn table can rotate 360 degrees to determine the position of the maximum emission level. The EUT is set 3 meters away from the receiving antenna which is mounted on a antenna tower. The antenna can be moved up and down from 1 to 4 meters to find out the maximum emission level. Rotated the EUT through three orthogonal axes to determine the maximum emissions, both horizontal and vertical polarization of the antenna are set on test. The EUT is tested in 9\*6\*6 Chamber. for Radiated emissions restricted band RBW= 1 MHz, VBW= 3 MHz.

### 10.2 Test SET-UP

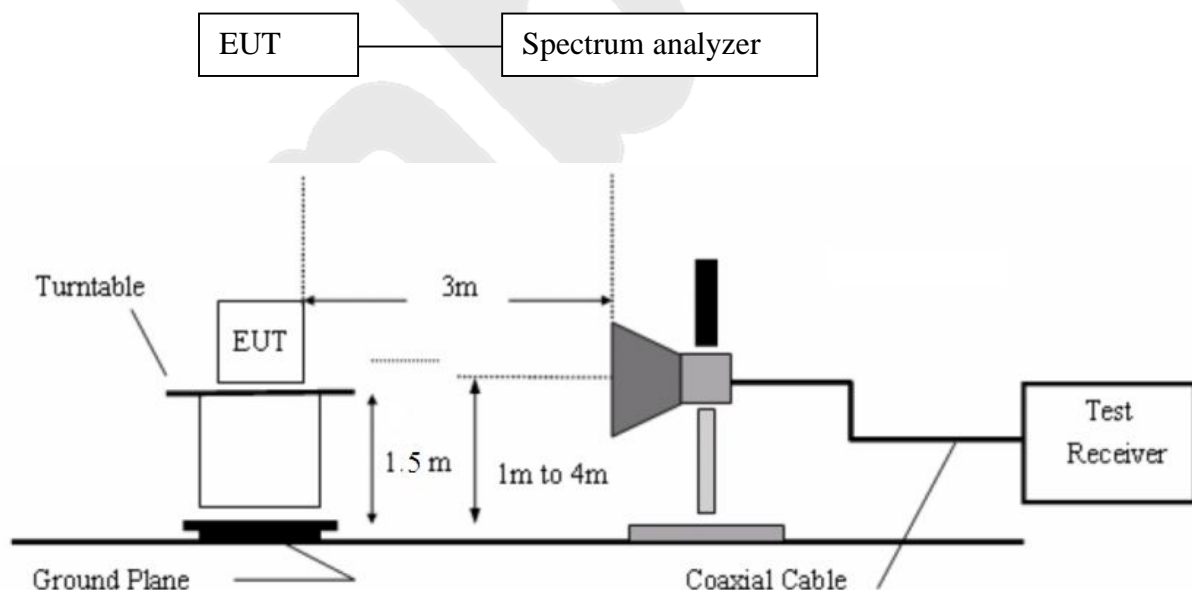

### 10.3 Test Equipment

Same as the equipment listed in 5.3.

### 10.4 Test Results

Pass.

Please refer the following data.

Test Item : Band eadge  
Test Voltage : DC 3.7V  
Test Result : PASS

Test Mode : CH Low ~ CH High  
Temperature : 24°C  
Humidity : 55%RH

**For Hopping Mode:**

Anbotek

Mode: BDR

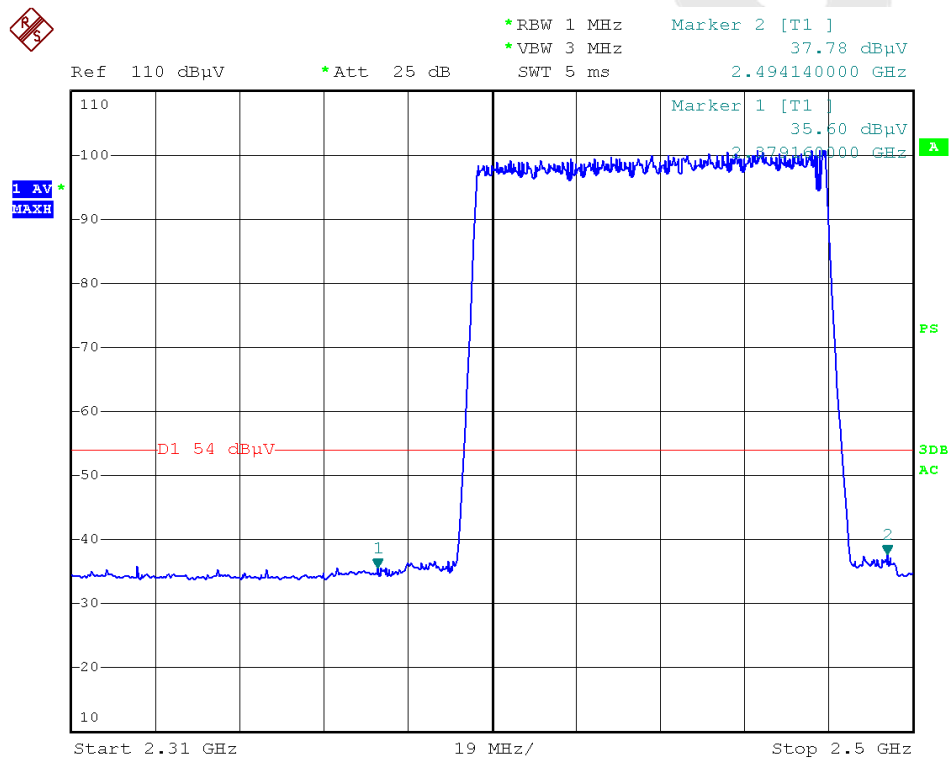
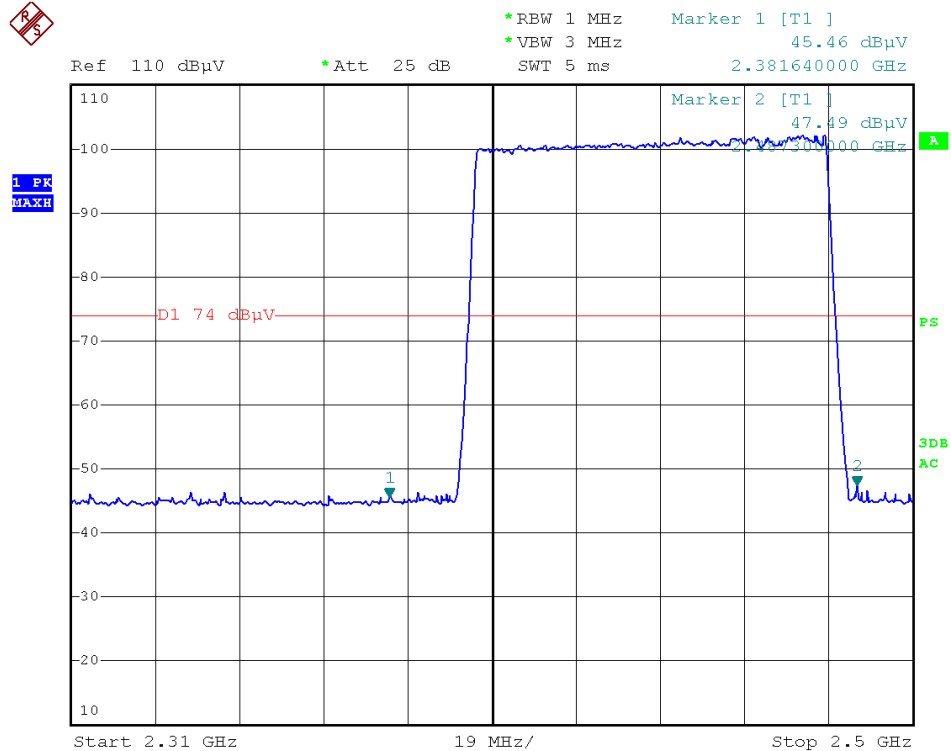

Mode: EDR

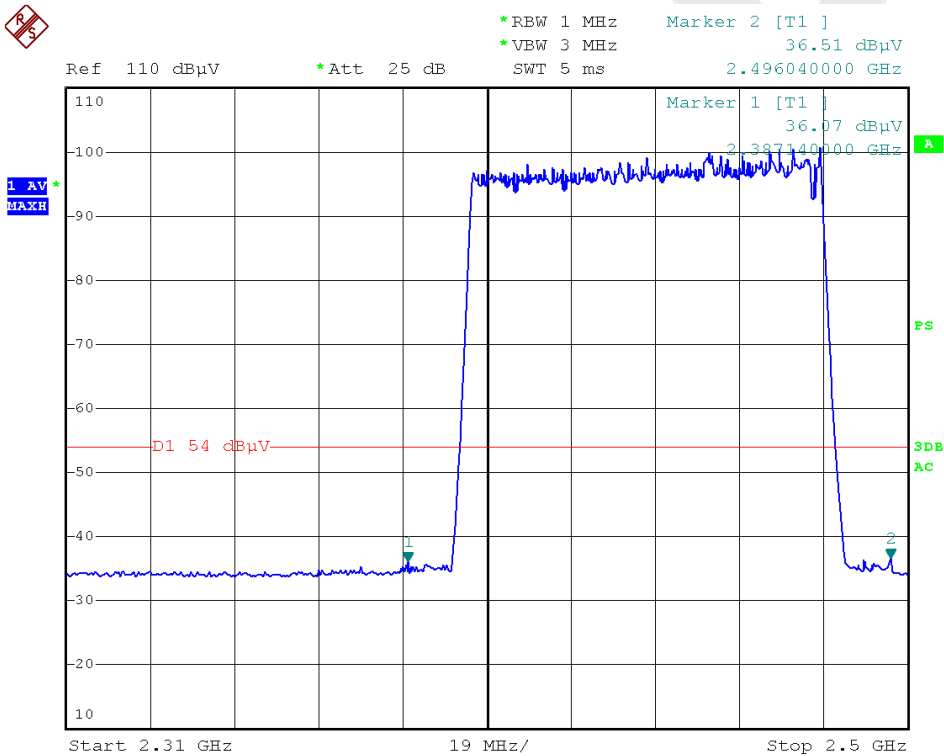
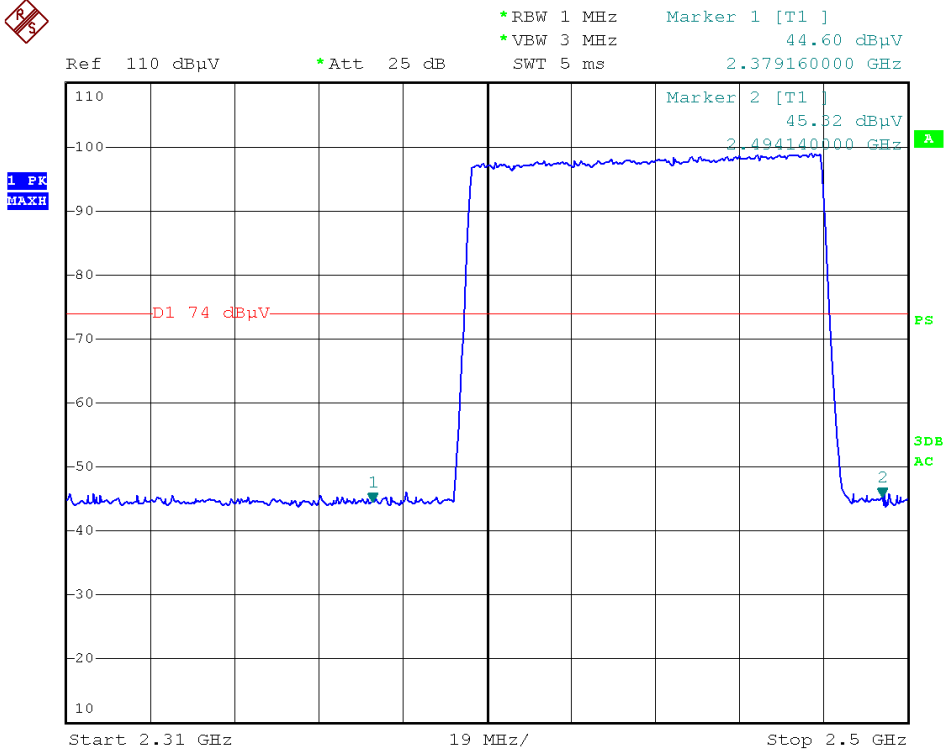

Test Item	: Band edge	Test Mode	: CH Low ~ CH High
Test Voltage	: DC 3.7V	Temperature	: 24°C
Test Result	: PASS	Humidity	: 55%RH

**For Non-Hopping Mode:**

1. Conducted Test

Frequency (MHz)	Peak Power Output(dBm)	Emission read Value(dBm)	Result of Band edge(dBc)	Band edge Limit(dBc)	Modulation
<2400	1.05	-53.06	49.72	>20dBc	BDR
	-0.72	-53.36	43.55	>20dBc	EDR
>2483.5	1.61	-53.98	47.08	>20dBc	BDR
	-0.11	-53.51	46.18	>20dBc	EDR

2. Radiated emission Test

Frequency (MHz)	Antenna polarization (H/V)	Emission (dBuV/m)		Band edge Limit (dBuV/m)		Modulation
		PK	AV	PK	AV	
<2400	V	57.34	37.37	74.00	54.00	BDR
	V	52.29	35.87	74.00	54.00	EDR
>2483.5	V	51.07	38.19	74.00	54.00	BDR
	V	53.16	36.69	74.00	54.00	EDR

Mode: BDR

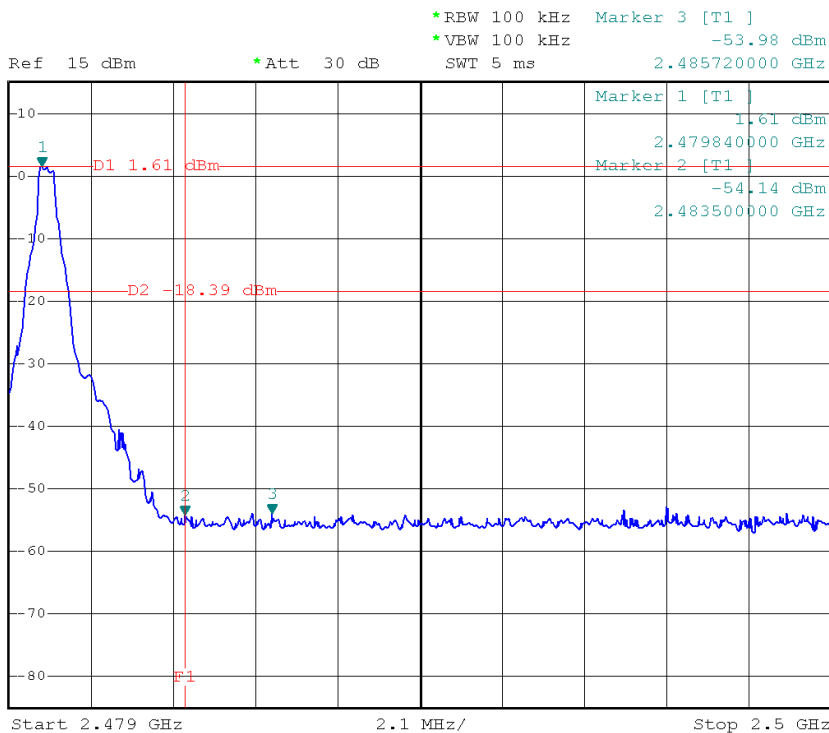
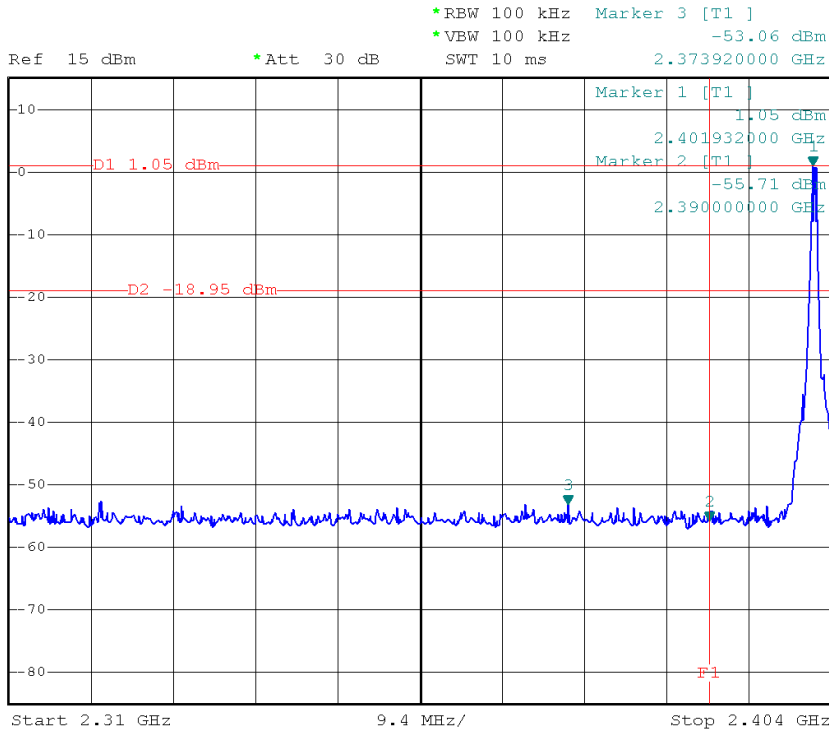

Mode: EDR

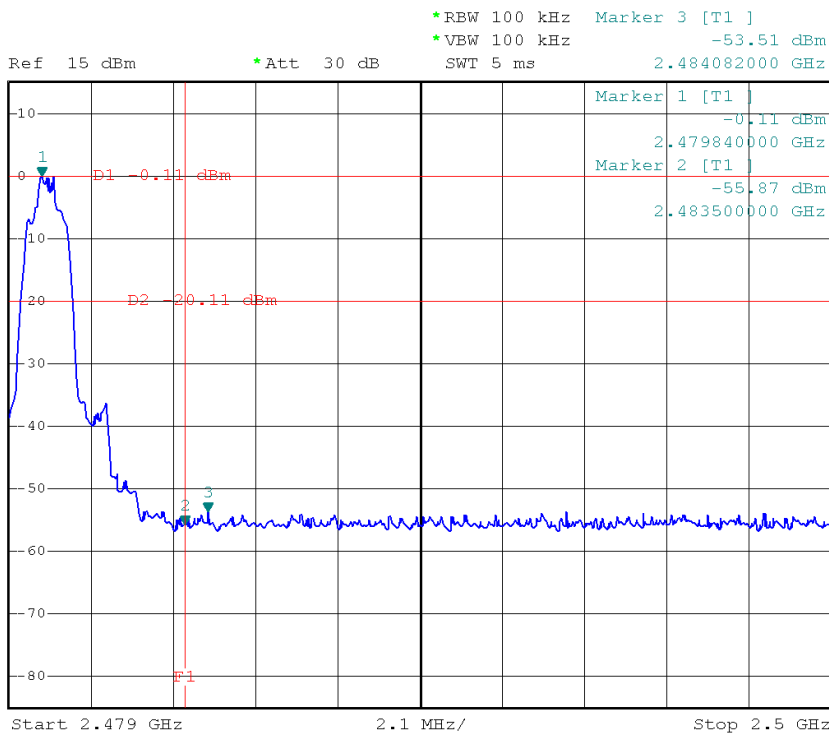
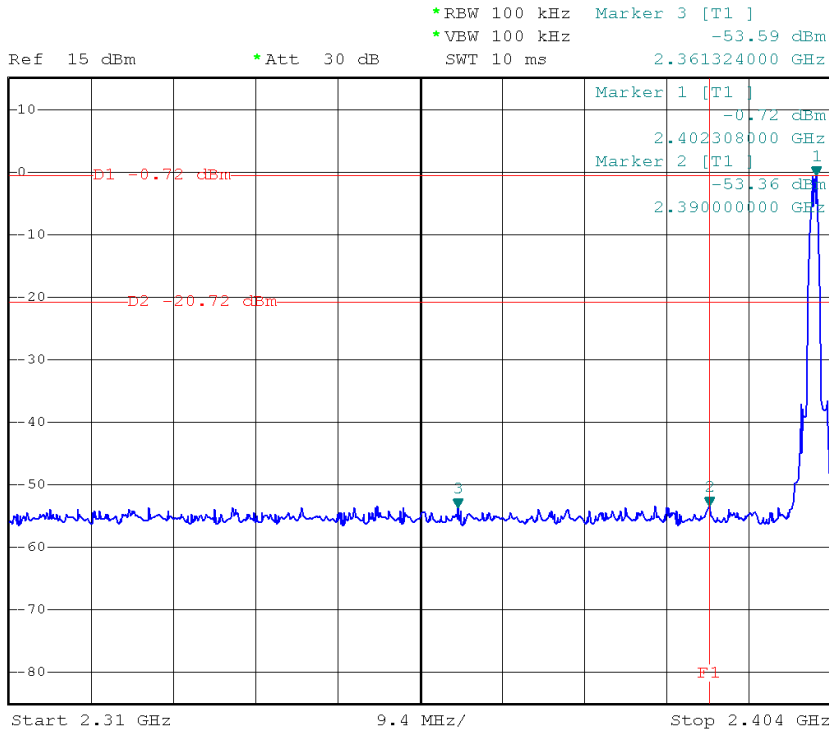



## 11. ANTENNA APPLICATION

### 11.1 Antenna requirement

The EUT'S antenna is met the requirement of FCC part 15C section 15.203 and 15.247.

FCC part 15C section 15.247 requirements:

Systems operating in the 2402-2480MHz band that are used exclusively for fixed, point-to-point operations may employ transmitting antennas with directional gain greater than 6dBi provided the maximum peak output power of the intentional radiator is reduced by 1dB for every 3dB that the directional gain of the antenna exceeds 6dBi.

### 11.2 Result

The EUT's antenna used a chip antenna and integrated on PCB, The antenna's gain is 0dBi and meets the requirement.

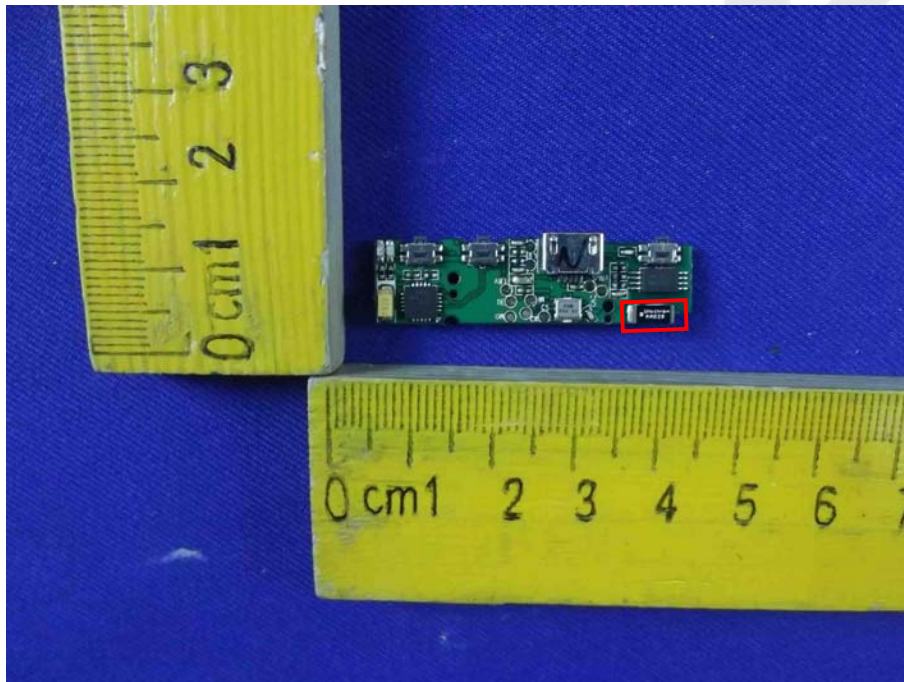

## 12. PHOTOGRAPH

### 12.1 Photo of Power Line Conducted Emission Measurement



### 12.2 Photo of Radiation Emission Test

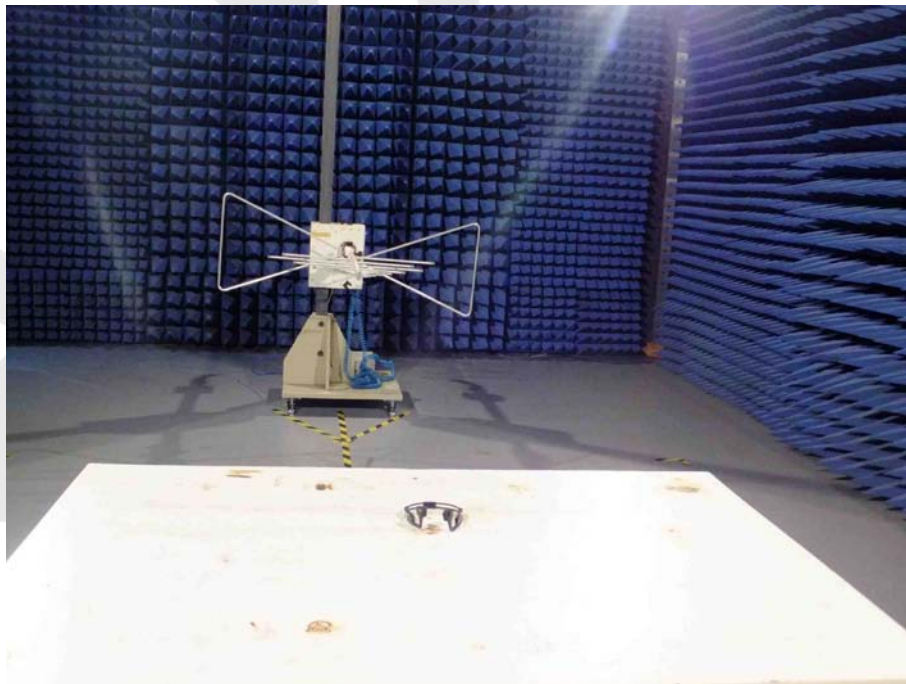

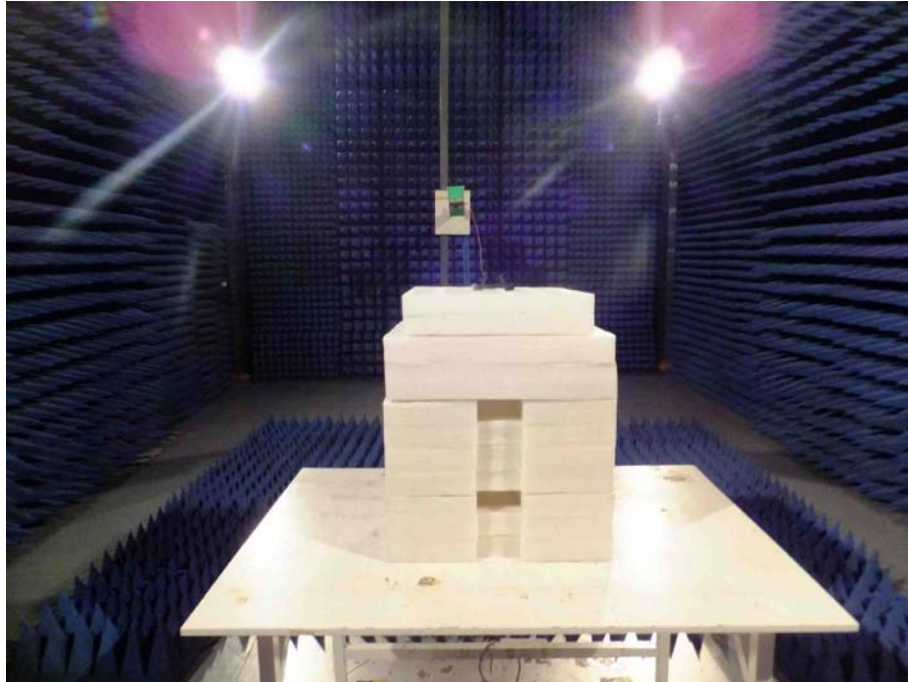

Anbotek

## APPENDIX I (EXTERNAL PHOTOS)

Figure 1  
The EUT-Top View



Figure 2  
The EUT-Bottom View



Figure 3  
The EUT-Front View



Figure 4  
The EUT-Back View



Figure 5  
The EUT-Right View



Figure 6  
The EUT-Left View



## APPENDIX II (INTERNAL PHOTOS)

Figure 7  
The EUT-Inside View



Figure 8  
The EUT-Inside View



Figure 9  
The EUT-Inside View



Figure 10  
The EUT-Inside View





Figure 11  
PCB of the EUT-Front View

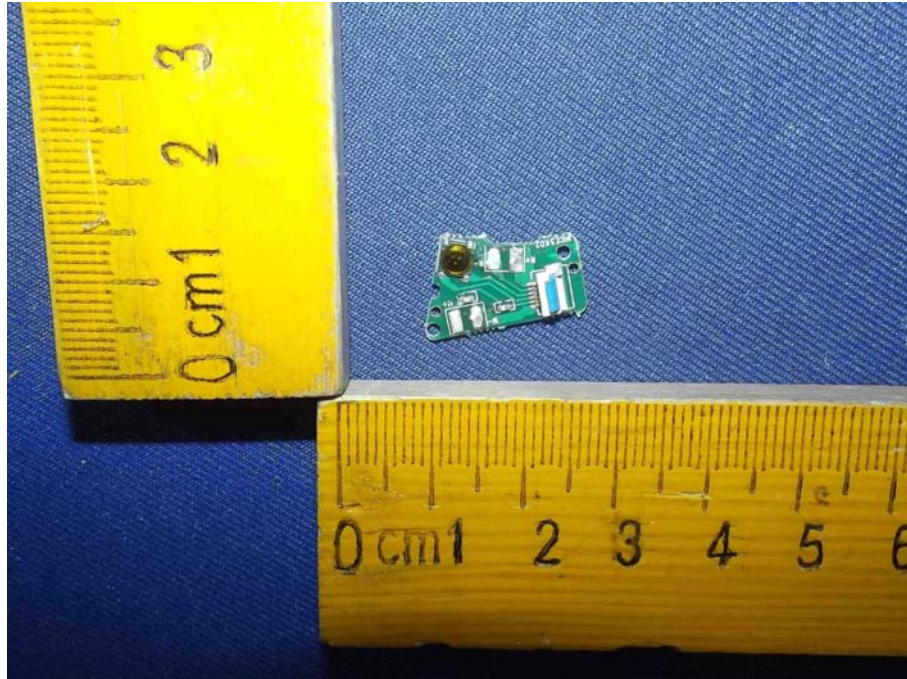

Figure 12  
PCB of the EUT-Back View



Figure 13  
The EUT-Battery View

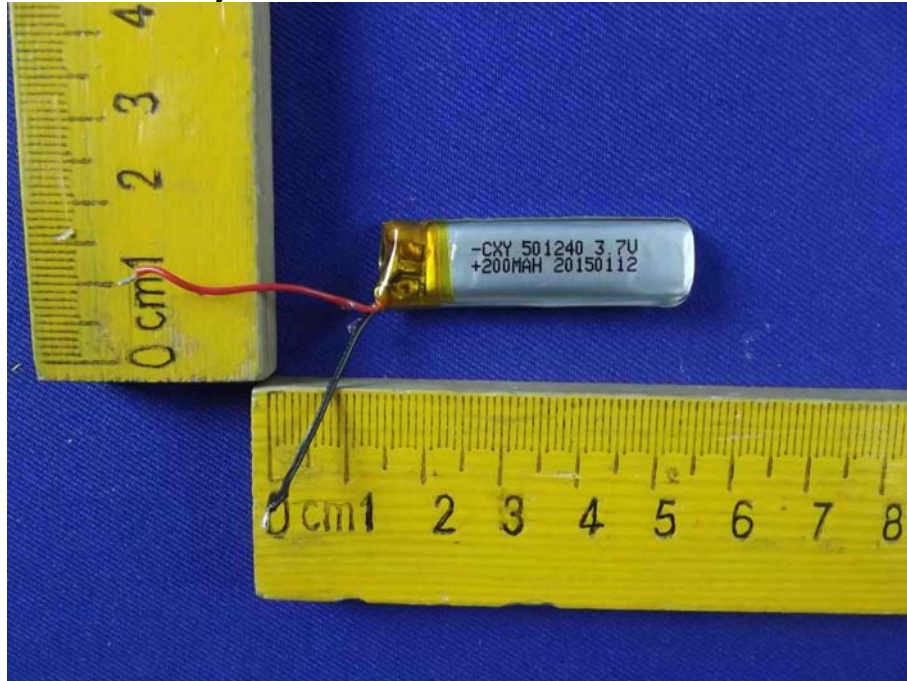

Figure 14  
PCB of the EUT-Front View

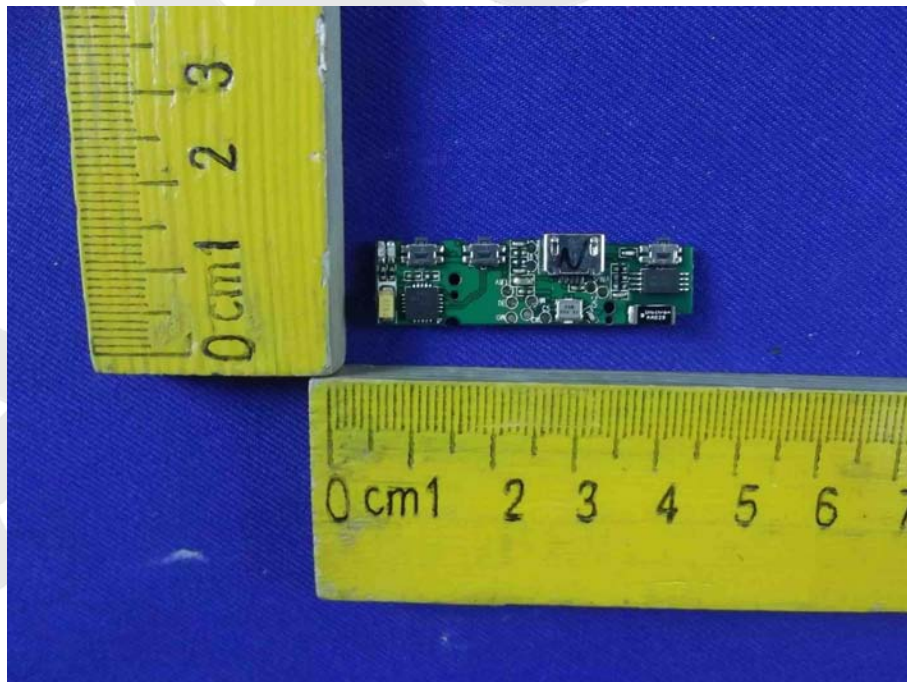

Figure 15  
PCB of the EUT-Back View

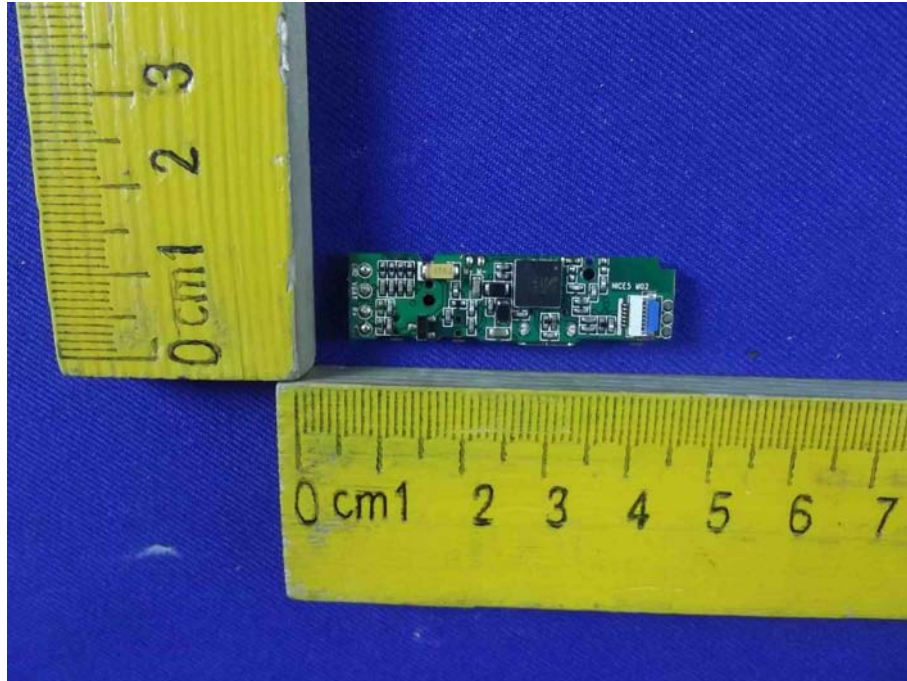

Figure 16  
PCB of the EUT-Front View

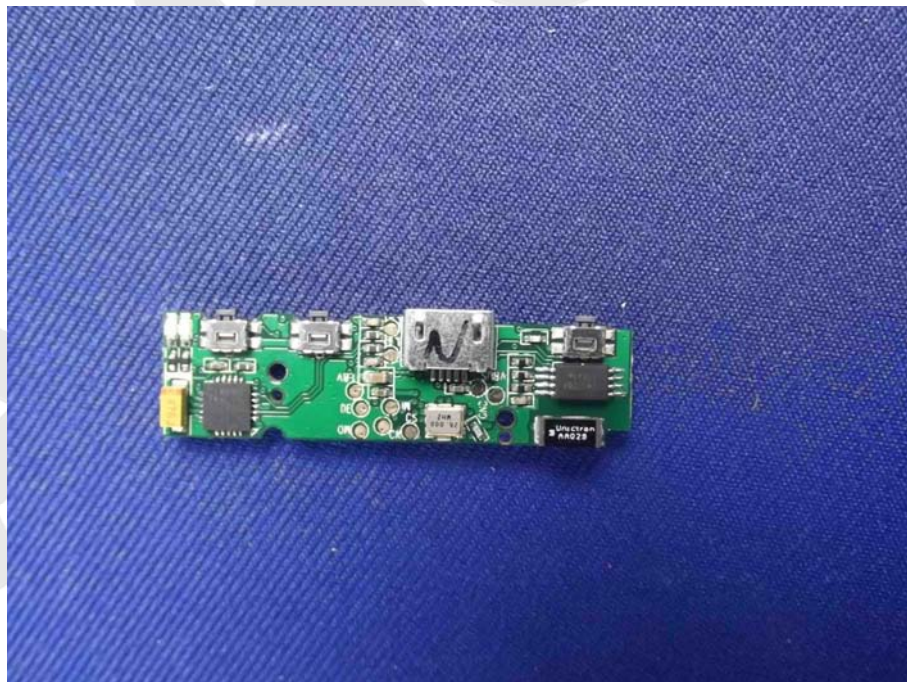

Figure 17  
PCB of the EUT-Back View

