

# SKW75 User Manual

## General Description

The module SKW75 compliant to 802.11 b/g/n Wi-Fi Solution for low power, low-cost, and highly integrated AP and consumer electronic devices, the module requiring only a external 3.3V power supply .

The module based on the single chip MT7620N which integrates an 802.11n MAC/BB/radio with internal PA and LNA. It supports 802.11n operations up to 144 Mbps for 20 MHz and 300 Mbps for 40 MHz channel respectively, and IEEE 802.11b/g data rates.

The module support AP mode and client mode and router mode.

## Applications

- AP WIFI
- 3G/4G wifi router
- Repeater WIFI
- IP TV
- IP DVD(Internet VOD Player)
- Set Top Box
- Home Gateways
- Gaming Consoles
- DVR

## Features

- Compliant to IEEE 802.11b/g/n WLANs
- 2T2R Mode with support for a 300Mbps TX/RX PHY rate.
- DDR2 memory up to 512Mb
- Flash memory up to 64Mb
- 4LAN ports and 1WAN port
- Support USB 2.0 host device
- Support USB disk.
- Support AP/Client/Router mode

- Security: WEP 64/128, WPA, WPA2, TKIP, AES, WAPI
- RoHS compliance meets environment-friendly requirement.
- 55(L) x 23(W) x 4.80(H) mm small dimension

**Module Pinout**

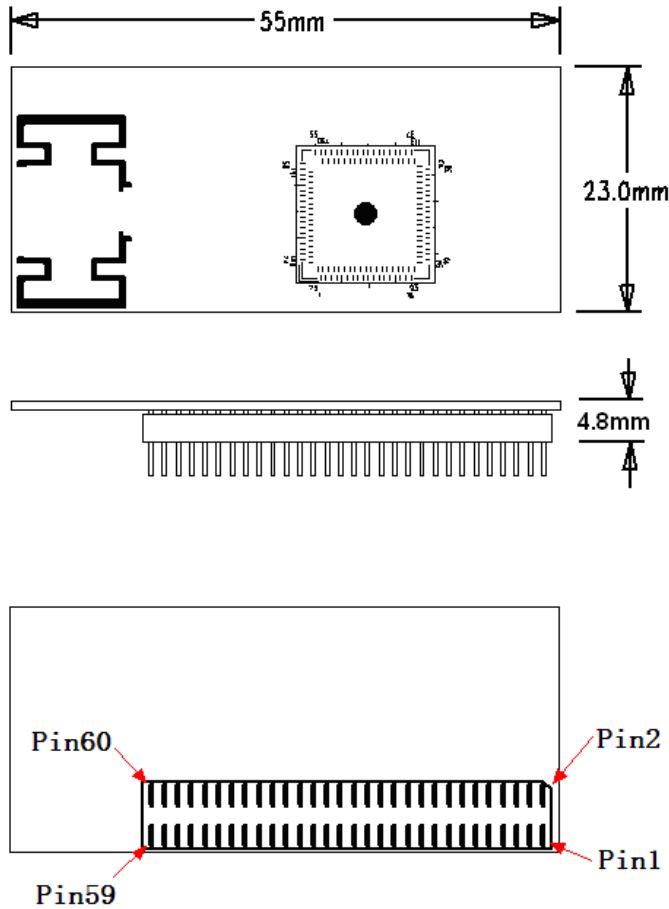

Figure 1: SKW75 Pin Name

**Pin Description**

1	PORT1_RX+	Ethernet port
2	PORT1_TX+	Ethernet port
3	PORT1_RX-	Ethernet port
4	PORT1_TX-	Ethernet port
5	PORT2_RX+	Ethernet port

6	NC	No Connect
7	PORT2_RX-	Ethernet port
8	NC	No Connect
9	PORT2_TX+	Ethernet port
10	LINK2	Port #2 activity LED
11	PORT2_TX-	Ethernet port
12	LINK3	Port #3 activity LED
13	PORT 3_TX+	Ethernet port
14	LINK4	Port #4 activity LED
15	PORT 3_TX-	Ethernet port
16	NC	No Connect
17	PORT 3_RX+	Ethernet port
18	NC	No Connect
19	PORT 3_RX-	Ethernet port
20	NC	No Connect
21	GND	Ground
22	VDD_3.3V	3.3V input 600mA, recommended voltage 3.3V,Min2.97V, MAX 3.63V
23	PORT0_RX+	Ethernet Wan port
24	NC	No Connect
25	PORT0_RX-	Ethernet Wan port
26	NC	No Connect
27	PORT0_TX+	Ethernet Wan port
28	NC	No Connect
29	PORT0_TX-	Ethernet Wan port
30	NC	No Connect
31	PORT4_RX+	Ethernet port
32	RESET	Resets the firmware to its default configuration
33	PORT4_RX-	Ethernet port:
34	WPS_PBC	WPS Input Pin
35	PORT4_TX+	Ethernet port
36	USB +	USB signal, carries USB data to and from the USB 2.0 PHY
37	PORT4_TX-	Ethernet port
38	USB -	USB signal, carries USB data to and from the USB 2.0 PHY
39	GND	Ground
40	NC	No Connect
41	NC	No Connect

42	GPIO0	GPO0(output only)
43	NC	No Connect
44	RESET	Resets the firmware to its default configuration, it has a internal
45	GND	Ground
46	WPS_PBC	WPS Input Pin
47	NC	No Connect
48	GND	Ground
49	NC	No Connect
50	VDD_3.3V	3.3V input 600mA, recommended voltage 3.3V,Min2.97V, MAX 3.63V
51	NC	No Connect
52	VDD_3.3V	3.3V input 600mA, recommended voltage 3.3V, Min2.97V, MAX 3.63V
53	LINK1	Port #1 activity LED
54	LINK0	Port #0 activity LED
55	WIRELESS_L	Wireless LED
56	NC	No Connect
57	UART_TX	Serial data out
58	UART_RX	Serial data in
59	GND	Ground
60	GND	Ground

### PCB Dimensions

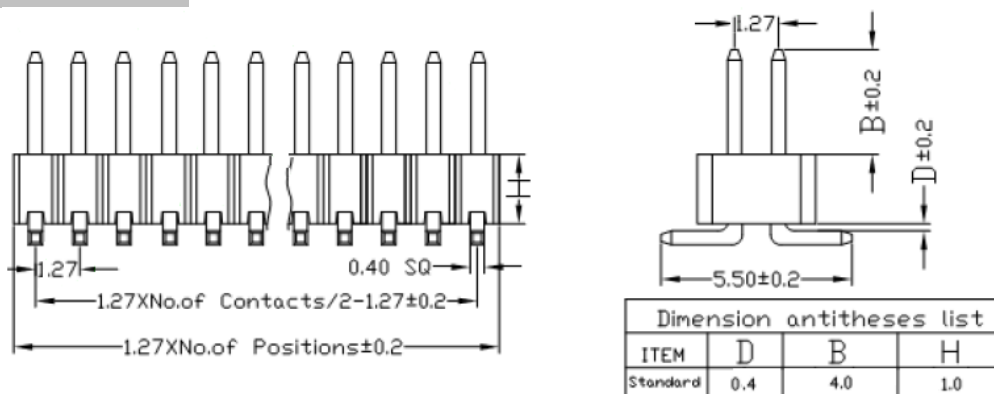
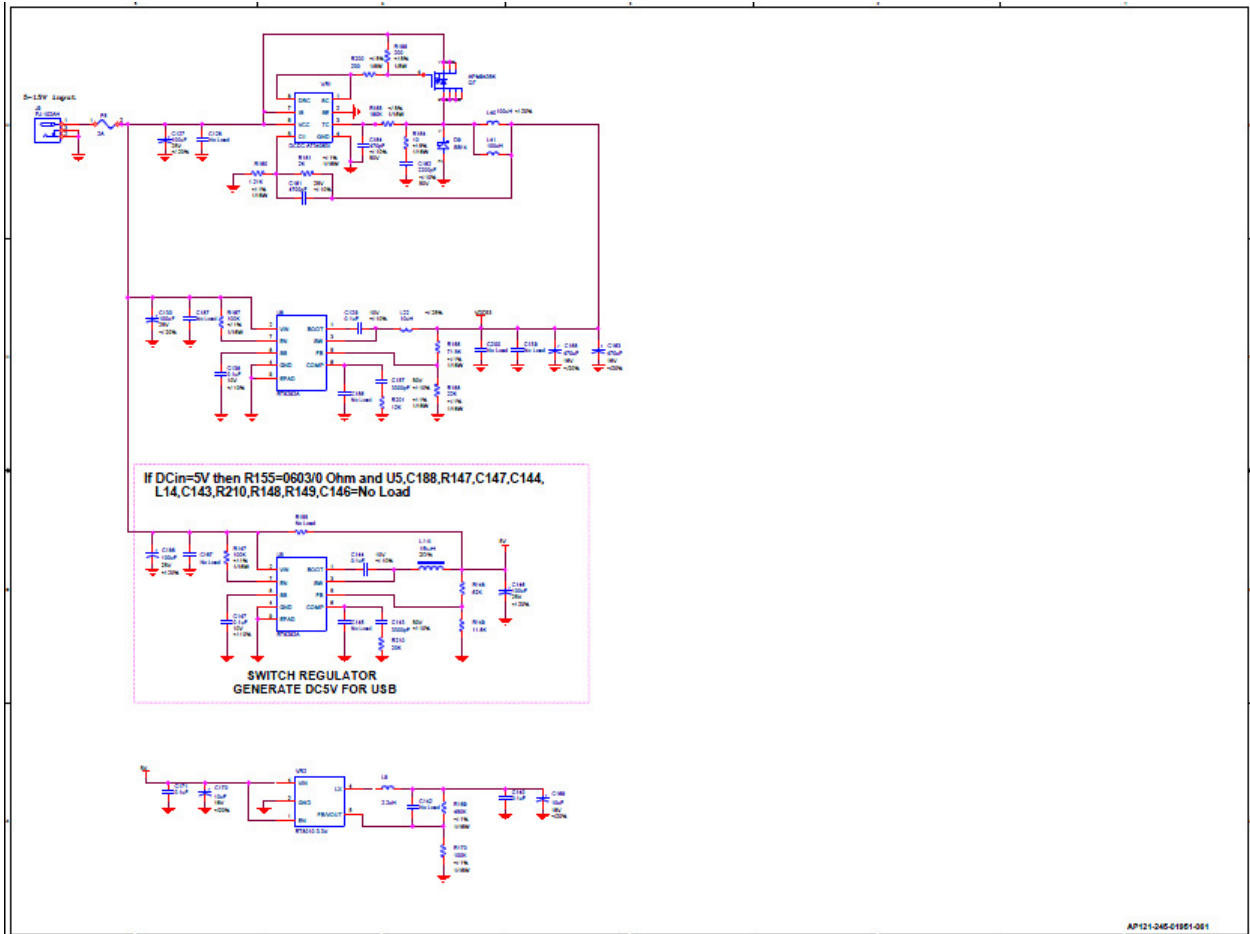
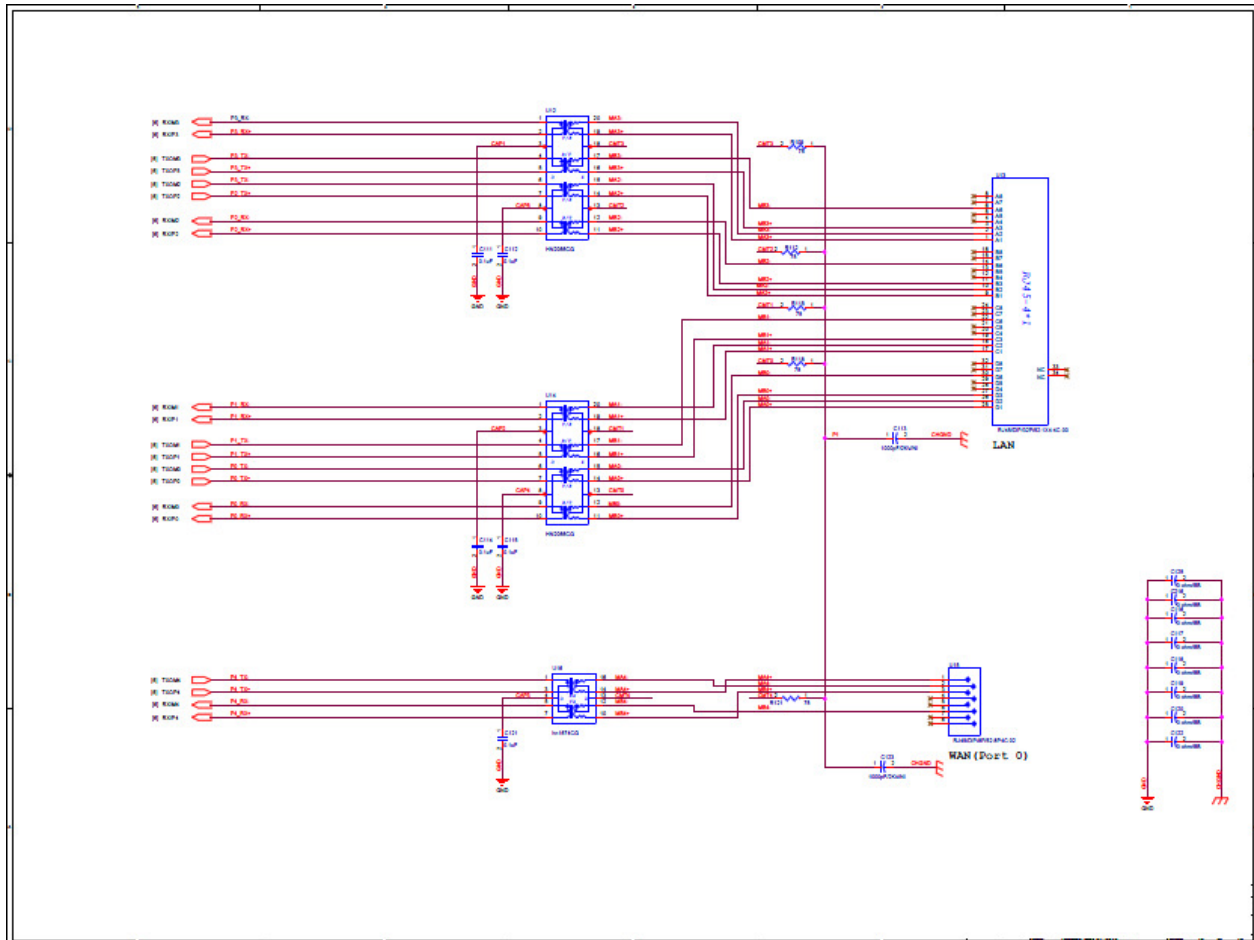

Figure 2: SKW75 Dimensions

### Reference design schematic





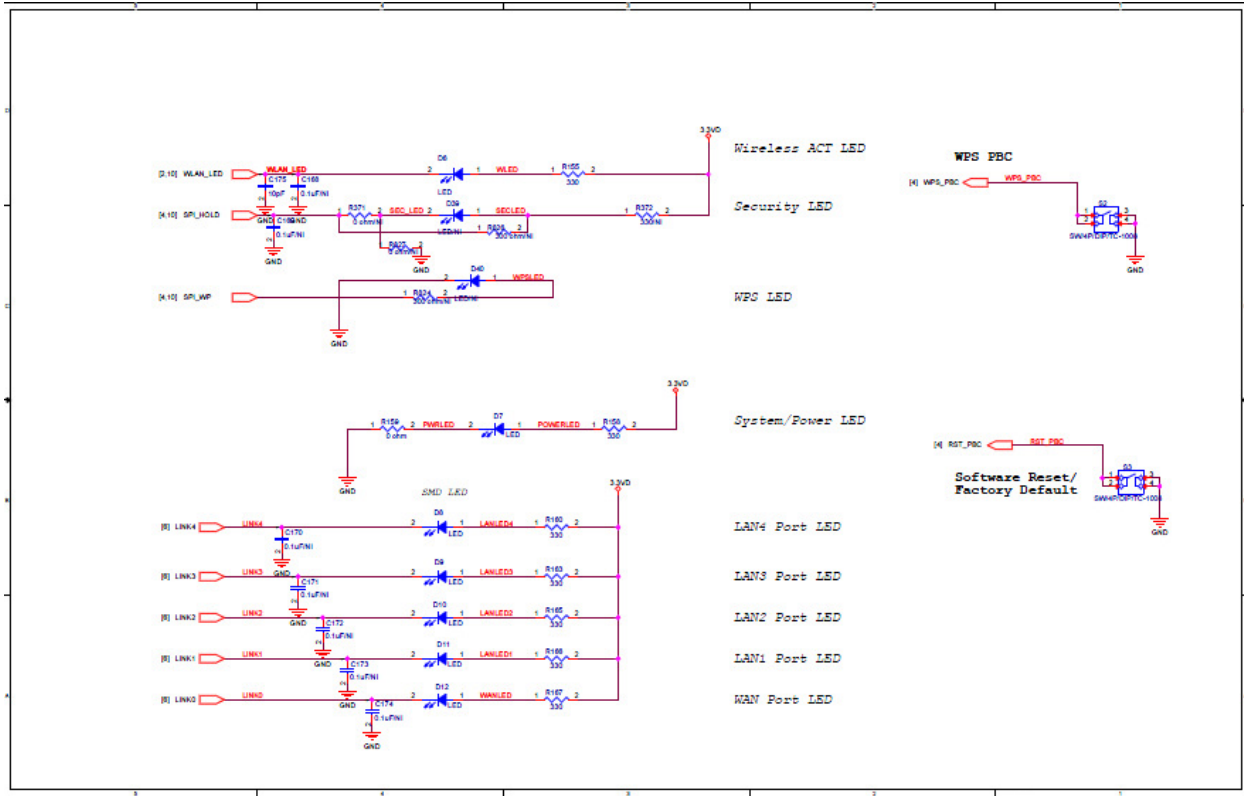

Figure 3: SKW75 Reference design schematic

## FCC Statement

Changes or modifications not expressly approved by the party responsible for compliance could void the user's authority to operate the equipment.

This equipment has been tested and found to comply with the limits for a Class B digital device, pursuant to Part 15 of the FCC Rules. These limits are designed to provide reasonable protection against harmful interference in a residential installation. This equipment generates uses and can radiate radio frequency energy and, if not installed and used in accordance with the instructions, may cause harmful interference to radio communications.

However, there is no guarantee that interference will not occur in a particular installation. If this equipment does cause harmful interference to radio or television reception, which can be determined by turning the equipment off and on, the user is encouraged to try to correct the interference by one or more of the following measures:

- Reorient or relocate the receiving antenna.
- Increase the separation between the equipment and receiver.
- Connect the equipment into an outlet on a circuit different from that to which the receiver is connected.
- Consult the dealer or an experienced radio/TV technician for help

This device complies with part 15 of the FCC rules. Operation is subject to the following two conditions (1) this device may not cause harmful interference, and (2) this device must accept any interference received, including interference that may cause undesired operation

### FCC Radiation Exposure Statement

The modular can be installed or integrated in mobile or fix devices only.

This modular cannot be installed in any portable device, for example, USB dongle like transmitters is forbidden.

This modular complies with FCC RF radiation exposure limits set forth for an uncontrolled environment. This transmitter must not be co-located or operating in conjunction with any other antenna or transmitter.

This modular must be installed and operated with a minimum distance of 20 cm between the radiator and user body.

If the FCC identification number is not visible when the module is installed inside another device, then the outside of the device into which the module is installed must also display a label referring to the enclosed module.

This exterior label can use wording such as the following:

"Contains Transmitter Module FCC ID:2ACOE-SKW75 Or Contains FCC ID:2ACOE-SKW75"

when the module is installed inside another device, the user manual of this device must contain below warning statements;

1. This device complies with Part 15 of the FCC Rules. Operation is subject to the following two conditions:

- (1) This device may not cause harmful interference.
- (2) This device must accept any interference received, including interference that may cause undesired operation.

2. Changes or modifications not expressly approved by the party responsible for compliance could void the user's authority to operate the equipment.

The devices must be installed and used in strict accordance with the manufacturer's instructions as described in the user documentation that comes with the product.