

SKB369 Bluetooth Module

Name: Bluetooth Module

Model No.: SKB369

Revision: V1.06

Revision History

Revision	Description	Approved	Date
V1.01	Initial Release	Hogan	20170103
V1.02	Revise The Product Picture	Hogan	20170414
V1.03	Revise Operating Temperature	Hogan	20170421
V1.04	Add Ordering Information Revise The Product Picture	Abner	20170801
V1.05	Revise PIN 23 function	George	20170821
V1.06	Update certification information	George	20170831

Contents

1. General Description	4
2. Applications.....	4
3. Features	4
4. Application Block Diagram.....	5
5. Interfaces.....	6
5.1 Power Supply	6
5.2 System Function Interfaces.....	6
5.2.1 GPIOs.....	6
5.2.2 Two-wire Interface (I2C Compatible).....	6
5.2.3 Flash Program I/Os.....	7
5.2.4 Serial Peripheral Interface	7
5.2.5 UARTs.....	8
5.2.6 Analog to Digital Converter (ADC).....	8
5.2.7 Low Power Comparator (LPCOMP).....	8
5.2.8 Reset.....	9
5.2.9 NFC	9
6. Module Specifications.....	10
7. Module Pinout and Pin Description	11
7.1 Module Pinout	11
7.2 Pin Description.....	12
8. PCB Design Guide	13
9. PCB Footprint and Dimensions.....	13
10. Electrical Characteristics.....	14
10.1 Absolute Maximum Ratings.....	14
10.2 Recommended Operation Ratings.....	14

10.3 Current.....	14
11. Manufacturing Process Recommendations	15
12. Packaging Specification	16
13. Ordering Information	16
14. Contact Information.....	17

1. General Description

The SKB369 is a highly integrated Bluetooth 4.2 BLE module, designed for high data rate, short-range wireless communication in the 2.4GHz ISM band. Also, SKB369 support ANT Protocol. The module is based on Nordic nRF52832 radio Transceiver IC, has a 32 bit ARM Cortex-M4F CPU, Flash memory and analog and digital peripherals. The SKB369 provides a low power and ultra-low cost BLE solution for wireless transmission applications. The SKB369 also has a NFC-A tag interface for OOB pairing.

2. Applications

- ◆ Computer peripherals and I/O devices
 - Mouse
 - Keyboard
 - Multi-touch trackpad
- ◆ Interactive entertainment devices
 - Remote control
 - 3D Glasses
 - Gaming controller
- ◆ Personal Area Networks
 - Health/fitness sensor and monitor devices
 - Medical devices
 - Key-fobs + wrist watches
- ◆ Remote control toys
- ◆ Beacons
- ◆ Bluetooth Gateway
- ◆ Indoor Location
- ◆ Colourful LED Control

3. Features

- ◆ Main Chip: nRF52832
- ◆ Bluetooth® 4.2 low energy single-mode



Figure 1: SKB369 Without Shielding Top View
protocol stack

L2CAP, ATT, GAP, GATT and SM protocols
Central and Peripheral roles
GATT Client and Server
Full SMP support including MITM and OOB

pairing

- ◆ Support ANT Protocol
- ◆ Supported data rates up to 1Mbps
- ◆ Support NFC-A
- ◆ 8/10/12 bit ADC-6configurable channels
- ◆ 19 General Purpose I/O pins
- ◆ SPI Master/Slave
- ◆ Two-wire Master (I2C compatible)
- ◆ UART (CTS/RTS)
- ◆ CPU independent Programmable Peripheral Interconnect (PPI)
- ◆ Quadrature Decoder (QDEC)
- ◆ AES HW encryption
- ◆ RoHS compliance (Lead-free)
- ◆ FCC,CE compliance

4. Application Block Diagram

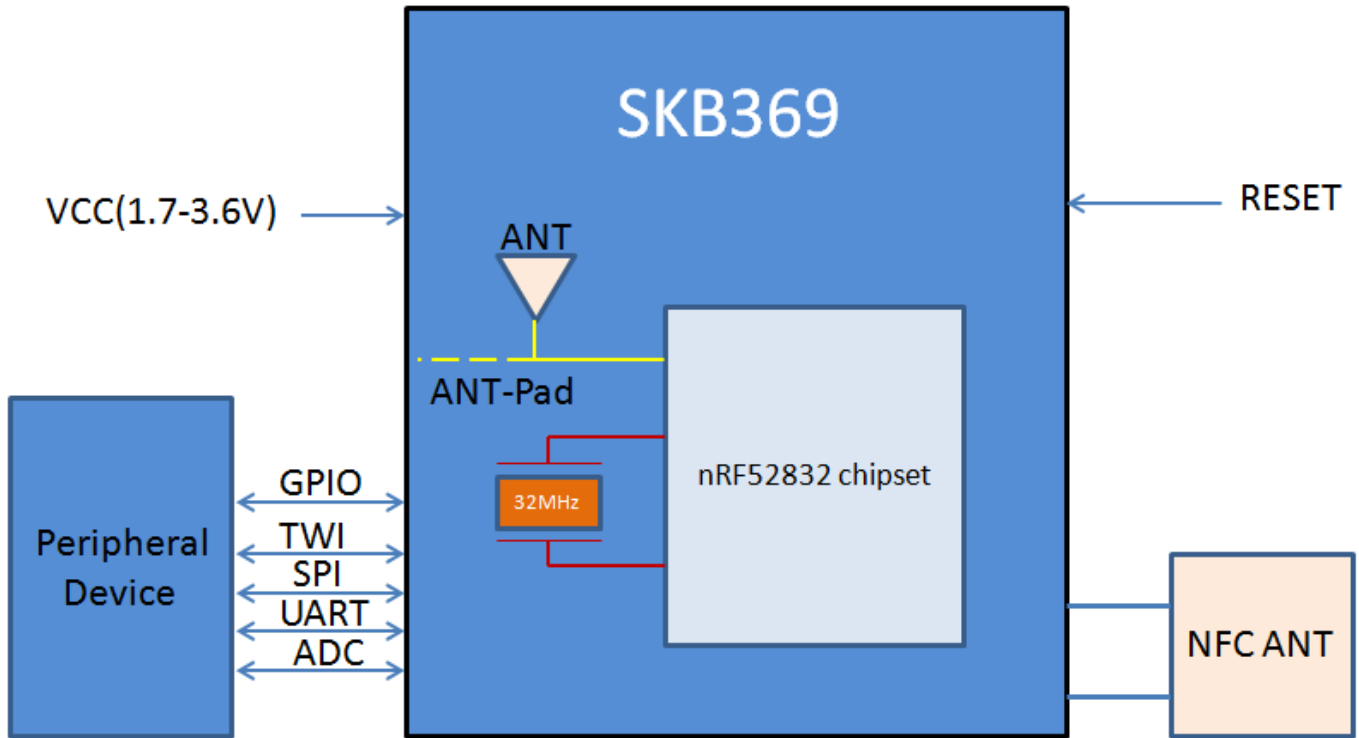

Figure 3: SKB369 Block Diagram

5. Interfaces

5.1 Power Supply

Regulated power for the SKB369 is required. The input voltage Vcc range should be 1.7V to 3.6V. Suitable decoupling must be provided by external decoupling circuitry (10uF and 0.1uF). It can reduce the noise from power supply and increase power stability.

5.2 System Function Interfaces

5.2.1 GPIOs

The general purpose I/O is organized as one port with up to 19 I/Os enabling access and control of up to 19 pins through one port. Each GPIO can be accessed individually with the following user configurable features:

- 1、 Input/output direction
- 2、 Output drive strength
- 3、 Internal pull-up and pull-down resistors
- 4、 Wake-up from high or low level triggers on all pins
- 5、 Trigger interrupt on all pins
- 6、 All pins can be used by the PPI task/event system; the maximum number of pins that can be interfaced through the PPI at the same time is limited by the number of GPIOTE channels
- 7、 All pins can be individually configured to carry serial interface or quadrature demodulator signals
- 8、 All pins can be configured as PWM signal.
- 9、 There are 6 ADC/LPCOMP input in the 19 I/Os.

5.2.2 Two-wire Interface (I2C Compatible)

The two-wire interface can communicate with a bi-directional wired-AND bus with two lines (SCL, SDA). The protocol makes it possible to interconnect up to 127 individually addressable devices. The interface is capable of clock stretching, supporting data rates of 100 kbps ,250kbps and 400 kbps. The module has 2 TWI ports and they properties like following table.

Instance	Master/Slave
TWI0	Master
TWI1	Master

Table5-1: TWI Pin Share Scheme

Note : I2C:Inter – Integrated Circuit

5.2.3 Flash Program I/Os

The module has two programmer pins, respectively SWDCLK pin and SWDIO pin. The two pin Serial Wire Debug (SWD) interface provided as a part of the Debug Access Port (DAP) offers a flexible and powerful mechanism for non-intrusive debugging of program code. Breakpoints and single stepping are part of this support.

5.2.4 Serial Peripheral Interface

The SPI interfaces enable full duplex synchronous communication between devices. They support a three-wire (SCK, MISO, MOSI) bi-directional bus with fast data transfers. The SPI Master can communicate with multiple slaves using individual chip select signals for each of the slave devices attached to a bus. Control of chip select signals is left to the application through use of GPIO signals. SPI Master has double buffered I/O data. The SPI Slave includes EasyDMA for data transfer directly to and from RAM allowing Slave data transfers to occur while the CPU is IDLE. The GPIOs are used for each SPI interface line can be chosen from any GPIOs on the device and configed independently. This enables great flexibility in device pinout and efficient use of printed circuit board space and signal routing.

The SPI peripheral support SPI mode 0,1,2,and 3.The module have 3 SPI ports and theirs they properties are as below:

Instance	Master/Slave
SPI0	Master
SPI1	Master
SPIS1	Slave

Table5-2: SPI Properties

5.2.5 UARTs

The Universal Asynchronous Receiver/Transmitter offers fast, full-duplex, asynchronous serial communication with built-in flow control (CTS, RTS), support in hardware up to 1 Mbps baud. Parity checking is supported.

Support the following baudrate in bps unit:

1200/2400/4800/9600/14400/19200/28800/38400/57600/76800/115200.

Note: The GPIOs are used for each SPI/TWI/UART interface line can be chosen from any GPIOs on the device and configed independently.

5.2.6 Analog to Digital Converter (ADC)

The 12 bit incremental Analog to Digital Converter (ADC) enables sampling of up to 8 external signals through a front-end multiplexer. The ADC has configurable input and reference prescaling, and sample resolution (8,10, and 12 bit).

Note: The ADC module uses the same analog inputs as the LPCOMP module. Only one of the modules can be enabled at the same time.

SKB369 Pin Number	Pin Number	Description
6	P0.28	Digital I/O; Analog input 4
7	P0.29	Digital I/O; Analog input 5
8	P0.30	Digital I/O; Analog input 6
9	P0.31	Digital I/O; Analog input 7
11	P0.02	Digital I/O; Analog input 2
12	P0.03	Digital I/O; Analog input 3

Table5-3: ADC Pins

5.2.7 Low Power Comparator (LPCOMP)

In System ON, the block can generate separate events on rising and falling edges of a signal, or sample the current state of the pin as being above or below the threshold. The block can be configured to use any of the analog inputs on the device. Additionally, the low power comparator can

be used as an analog wakeup source from System OFF or System ON. The comparator threshold can be programmed to a range of fractions of the supply voltage.

5.2.8 Reset

The reset pin of the SKB369 module is in the internal pull-high state , when the reset pin of the module is input to a low level , the module will be automatically reset .After the reset pin is used , the parameters of the current setting will not be ANT .

5.2.9 NFC

The NFC peripheral (referred to as the 'NFC peripheral' from now on) supports communication signal interface type A and 106 kbps bit rate from the NFC Forum.

With appropriate software, the NFC peripheral can be used to emulate the listening device NFC-A as specified by the NFC Forum.

Listed here are the main features for the NFC peripheral:

- NFC-A listen mode operation
- 13.56 MHz input frequency
- Bit rate 106 kbps
- Wake-on-field low power field detection (SENSE) mode
- Frame assemble and disassemble for the NFC-A frames specified by the NFC Forum
- Programmable frame timing controller
- Integrated automatic collision resolution, CRC and parity functions

SKB369 Pin Number	Pin Number	Description
16	P0.09	Digital I/O; NFC1
17	P0.10	Digital I/O; NFC2

Table5-4: ADC Pins

6. Module Specifications

Hardware Features	
Model	SKB369
ANTenna Type	PCB ANTenna
Chipset Solution	nRF52832
Voltage	1.7V~3.6V
Dimension(L×W×H)	17.4×13.7×1.9 mm
Wireless Features	
Wireless Standards	Bluetooth ® 4.2,ANT
Frequency Range	2400MHz---2483.5MHz
Data Rates	1Mbps(Bluetooth ® 4.2)
Modulation Technique	GFSK Modulation(Bluetooth ® 4.2)
Wireless Security	AES HW Encryption
Transmit Power	Tx Power -20 to +4 dBm in 4 dB Steps(Bluetooth ® 4.2)
Work Mode	Central/Peripheral(Bluetooth ® 4.2)
Others	
Certification	RoHS
Environment	Operating Temperature: -40C°~85C°
	Storage Temperature: -40C°~125C°
	Operating Humidity: 10%~90% Non-condensing
	Storage Humidity: 5%~90% Non-condensing

7. Module Pinout and Pin Description

7.1 Module Pinout

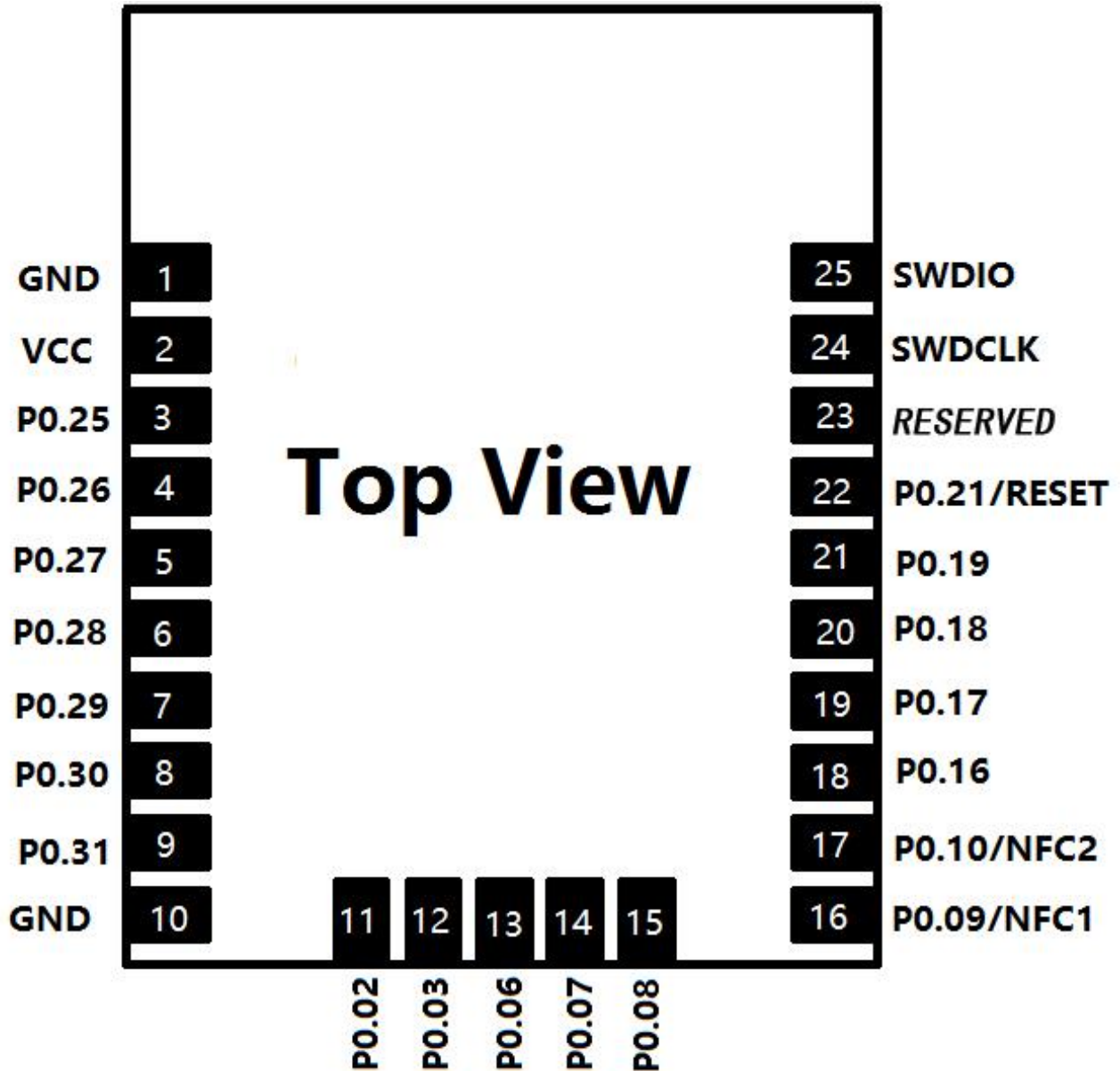

Figure 4: SKB369 Module Pinout

7.2 Pin Description

Pin No.	Pin Name	Description	Remark
1	GND	Ground	
2	VCC	Main Power Supply	1.7V to 3.6V
3	P0.25	General Purpose I/O	Digital I/O
4	P0.26	General Purpose I/O	Digital I/O
5	P0.27	General Purpose I/O	Digital I/O
6	P0.28	Digital I/O; Analog input	ADC/LPCOMP input 4
7	P0.29	Digital I/O; Analog input	ADC/LPCOMP input 5
8	P0.30	Digital I/O; Analog input	ADC/LPCOMP input 6
9	P0.31	Digital I/O; Analog input	ADC/LPCOMP input 7
10	GND	Ground	
11	P0.02	Digital I/O; Analog input	ADC/LPCOMP input 0
12	P0.03	Digital I/O; Analog input	ADC/LPCOMP input 1
13	P0.06	General Purpose I/O	Digital I/O
14	P0.07	General Purpose I/O	Digital I/O
15	P0.08	General Purpose I/O	Digital I/O
16	P0.09/NFC1	Digital I/O;NFC1	Digital I/O;NFC1
17	P0.10/NFC2	Digital I/O;NFC2	Digital I/O;NFC2
18	P0.16	General Purpose I/O	Digital I/O
19	P0.17	General Purpose I/O	Digital I/O
20	P0.18	General Purpose I/O	Digital I/O
21	P0.19	General Purpose I/O	Digital I/O
22	P0.21/RESET	Digital I/O; System Reset (Active low)	Digital I/O; Reset
23	ANT		
24	SWDCLK	Hardware debug and Flash program I/O	Digital input
25	SWDIO	Hardware Debug and Flash Program I/O	Digital I/O

8. PCB Design Guide

Please reserve empty area for PCB ANTenna when you are going to design a device's board, the empty range minimum size :

16.5*6.6mm , please kindly check the "PCB footprint and Dimensions" for reference.

9. PCB Footprint and Dimensions

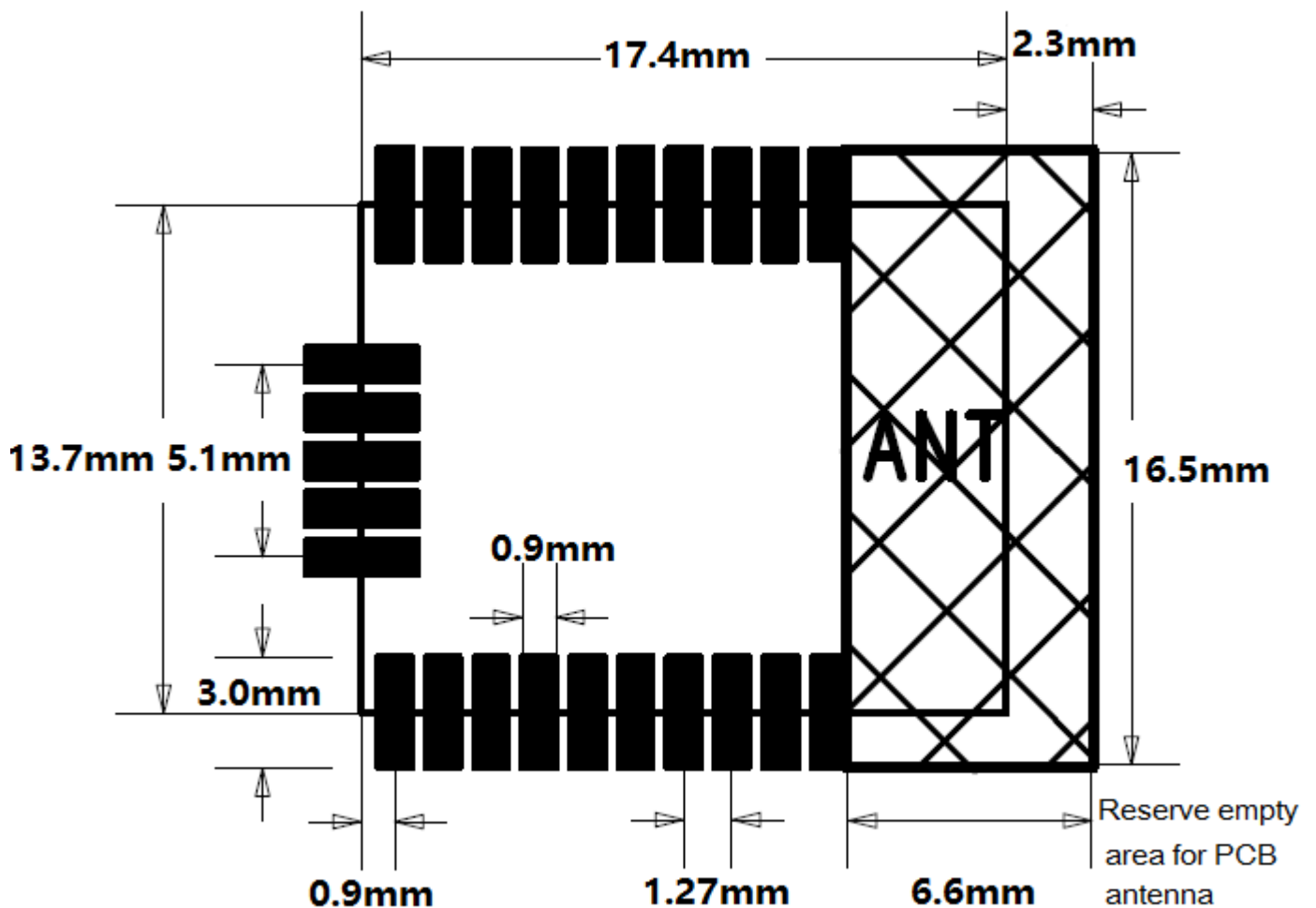

Figure 5: SKB369 Recommended PCB Footprint

10. Electrical Characteristics

10.1 Absolute Maximum Ratings

Parameter	Condition	Min.	Typ.	Max.	Unit
Storage Temperature Range		-40		125	°C
ESD Protection	VESD	/		4000	V
Supply Voltage	VCC	-0.3		3.9	V
Voltage On Any I/O Pin		-0.3		3.63	V

Table10-1: Absolute Maximum Ratings

10.2 Recommended Operation Ratings

Parameter	Symbol	Min.	Typ.	Max.	Unit
Extended Temp. Range	TA	-40	25	85	°C
Power Supply	VCC	1.7	3.3	3.6	V
Input Low Voltage	VIL	0		0.3*VCC	V
Input High Voltage	VIH	0.7*VCC		VCC	V

Table10-2: Operating Conditions

10.3 Current

System State	TX Peak @4dBm	RX Peak	Sleep Mode (avg)	Idle Mode (avg)
Current (peak)@3V	7.5 mA	5.4 mA	0.4uA	1.2uA

Table10-3: Power Consumption in Different States

11. Manufacturing Process Recommendations

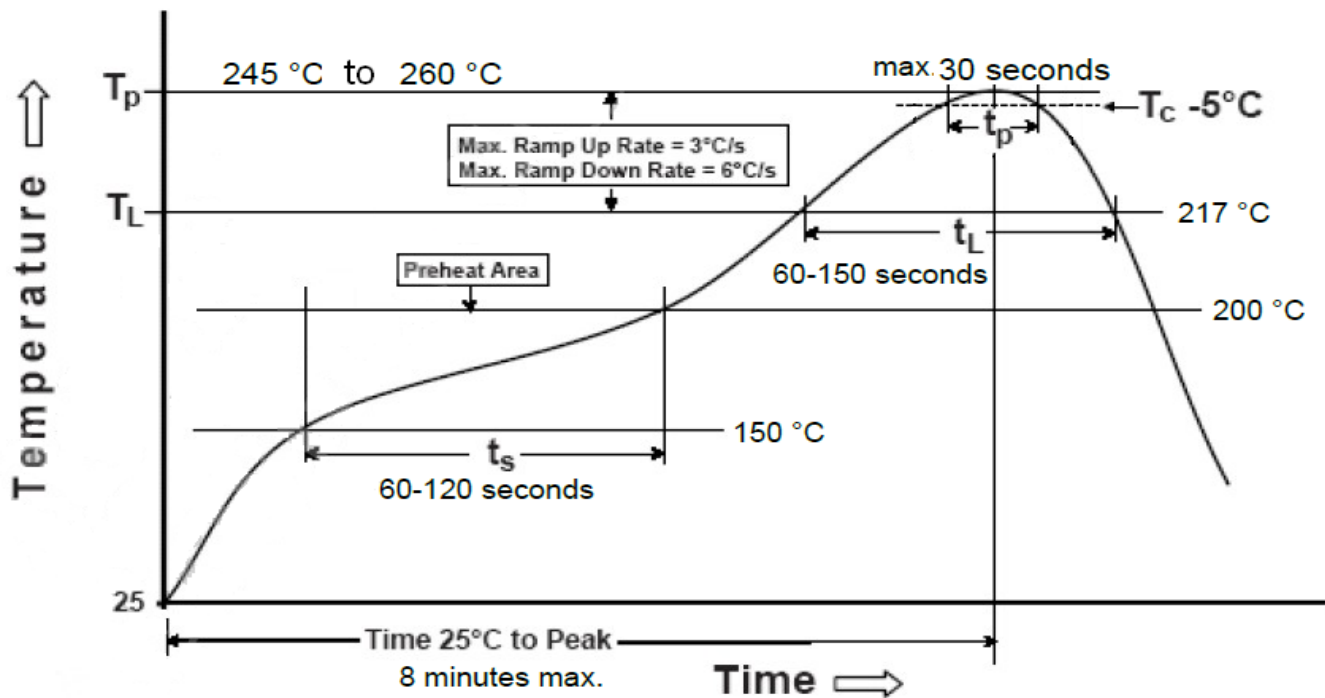

Figure 6: SKB369 Typical Lead-free Soldering Profile

Note : The final re-flow soldering temperature map chosen at the factory depends on additional external factors, for example, choice of soldering paste, size, thickness and properties of the module's baseboard etc. Exceeding the maximum soldering temperature in the recommended soldering profile may permanently damage the module.

12. Packaging Specification

SKB369 modules are put into tray and 528 units per tray. Each tray is 'dry' and vacuum packaging.

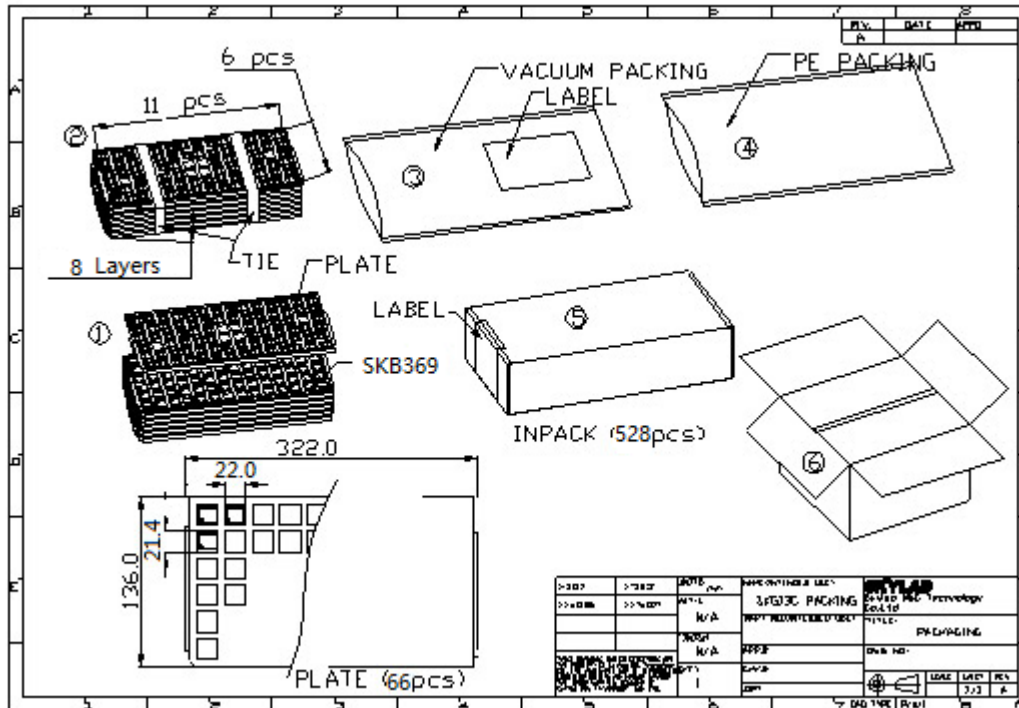

Figure 7: SKB369 Packaging

13. Ordering Information

Module No.	Crystal	Shielding	ANTenna	Temperature Grade
SKB369-CSPI	32.768K	Shielding	PCB	Industry
SKB369-XXPI	No	No	PCB	Industry

CE Statement

Herby, Skylab M&C Technology Co., Ltd declares that this Bluetooth Module, SKB369 is in compliance with the essential requirements and other relevant provisions of Directive 2014/53/EU.

The operation temperature range is -40°C to 85°C

Frequency Range: 2402MHz-2480MHz

The frequency can be used in Europe without restriction.

Maximum transmit power: 40.79mW

Manufacture: Skylab M&C Technology Co., Ltd

Address: 6 Floor, Building 9, Lijincheng Scientific & Technical park,

Gongye East Road, Longhua District, Shenzhen, China

TEL: +86-0755-27789180

Fax: +86-0755-83458560

E-mail: Mary.meng@skylab.com.cn

FCC Statement

Changes or modifications not expressly approved by the party responsible for compliance could void the user's authority to operate the equipment.

This equipment has been tested and found to comply with the limits for a Class B digital device, pursuant to Part 15 of the FCC Rules. These limits are designed to provide reasonable protection against harmful interference in a residential installation. This equipment generates uses and can radiate radio frequency energy and, if not installed and used in accordance with the instructions, may cause harmful interference to radio communications. However, there is no guarantee that interference will not occur in a particular installation. If this equipment does cause harmful interference to radio or television reception, which can be determined by turning the equipment off and on, the user is encouraged to try to correct the interference by one or more of the following measures:

- Reorient or relocate the receiving antenna.
- Increase the separation between the equipment and receiver.
- Connect the equipment into an outlet on a circuit different from that to which the receiver is connected.
- Consult the dealer or an experienced radio/TV technician for help

This device complies with part 15 of the FCC rules. Operation is subject to the following two conditions (1) this device may not cause harmful interference, and (2) this device must accept any interference received, including interference that may cause undesired operation.

FCC Radiation Exposure Statement

The modular can be installed or integrated in mobile or fix devices only. This modular be installed in any portable device, for example, USB dongle like transmitters is forbidden. This modular complies with FCC RF radiation exposure limits set forth for an uncontrolled environment. This transmitter must not be collocated or operating in conjunction with antenna or transmitter.

If the FCC identification number is not visible when the module is installed inside another device, then the outside of the device into which the module is installed must also display label referring to the enclosed module.

This exterior label can use wording such as the following:

“Contains Transmitter Module FCC ID:2ACOE-SKB369 Or Contains FCC ID:2ACOE-SKB369 when the module is installed inside another device, the user manual of this device must contain below warning statements;

1. This device complies with Part 15 of the FCC Rules. Operation is subject to the following two conditions:

(1) This device may not cause harmful interference.

(2) This device must accept any interference received, including interference that may undesired operation.

2. Changes or modifications not expressly approved by the party responsible for compliance could void the user's authority to operate the equipment.

The devices must be installed and used in strict accordance with the manufacturer's instructions as described in the user documentation that comes with the product.

This device is intended only for OEM integrators under the following conditions:

1) The antenna must be installed such that 20 cm is maintained between the antenna and user.

2) The transmitter module may not be collocated with any other transmitter or antenna. Module Antenna Type: PCB ANT, 1dBi gain

15. Contact Information

Skylab M&C Technology Co., Ltd.

深圳市天工测控技术有限公司

Address: 6 Floor, No.9 Building, Lijincheng Scientific & Technical park, Gongye East Road,
Longhua District, Shenzhen, Guangdong, China

Phone: 86-755 8340 8210 (Sales Support)

Phone: 86-755 8340 8510 (Technical Support)

Fax: 86-755-8340 8560

E-Mail: sales1@skylab.com.cn

Website: www.skylab.com.cn www.skylabmodule.com