



# FCC PART 15C TEST REPORT

For

## I/O INTERCONNECT INC.

5F, No.19-3, Sanchong Rd., Nangang District, Taipei 115, Taiwan

**FCC ID: 2ACNORA843**

<b>Report Type</b> Original Report	<b>Product Type:</b> Wireless Charging Pad+Dock
<p><b>Report Producer :</b> <u>Kaylee Chiang</u> <i>Kaylee Chiang</i></p> <p><b>Report Number :</b> <u>RXZ181116001-00C</u></p> <p><b>Report Date :</b> <u>2018-12-12</u></p> <p><b>Reviewed By:</b> <u>Jerry Chang</u> <i>Jerry Chang</i></p> <p><b>Prepared By:</b> Bay Area Compliance Laboratories Corp.(Taiwan)          70, Lane 169, Sec. 2, Datong Road, Xizhi Dist.,          New Taipei City 22183, Taiwan, R.O.C.          Tel: +886 (2)2647 6898          Fax: +886 (2) 2647 6895          www.bacl.com.tw</p>	

## Revision History

Revision	No.	Report Number	Issue Date	Description	Author/ Revised by
1.0	RXZ181116001	RXZ181116001-00C	2018.12.12	Original Report	Kaylee

## TABLE OF CONTENTS

<b>General Information</b> .....	4
Product Description for Equipment under Test (EUT) .....	4
Objective .....	4
Related Submittal(s)/Grant(s).....	4
Test Methodology .....	5
Test Facility.....	5
<b>System Test Configuration</b> .....	6
Description of Test Configuration.....	6
EUT Exercise Software .....	6
Special Accessories .....	6
Equipment Modifications .....	6
Support Equipment List and Details .....	7
External Cable List and Details.....	7
Block Diagram of Test Setup .....	8
<b>Summary of Test Results</b> .....	9
<b>Test Equipment List and Details</b> .....	10
<b>FCC §15.203 – Antenna Requirement</b> .....	12
Applicable Standard .....	12
Antenna Connected Construction.....	12
Result: Compliance. ....	12
<b>FCC §1.1310 &amp; §2.1091 –MAXIMUM PERMISSIBLE EXPOSURE (MPE)</b> .....	13
Applicable Standard .....	13
EUT Setup.....	14
Test Result.....	14
<b>FCC §15.207 – AC Line Conducted Emissions</b> .....	16
Applicable Standard .....	16
Measurement Uncertainty .....	16
EUT Setup.....	17
EMI Test Receiver Setup .....	17
Test Procedure.....	18
Factor & Over Limit Calculation .....	18
Test Results Summary.....	18
Environmental Conditions.....	18
Test Results .....	19
<b>FCC §15.205 &amp; §15.209 – Radiated Emissions</b> .....	21
Applicable Standard .....	21
Measurement Uncertainty .....	22
EUT Setup.....	22
EMI Test Receiver Setup .....	23
Test Procedure.....	23
Correct Factor & Margin Calculation.....	24
Test Results Summary.....	24
Environmental Conditions.....	24
Test Results .....	25

## General Information

### Product Description for Equipment under Test (EUT)

Applicant	I/O INTERCONNECT INC.
	5F, No.19-3, Sanchong Rd., Nangang District, Taipei 115, Taiwan
Manufacturer	ShengHua Electronics (DongGuan) Co., LTD.
	No. 4, Third road, High New Technology Industrial Zone, Tang xia Town, Dong Guan City, Guangdong Province, China 523716
Brand(Trade) Name	MediaGear
Product (Equipment)	Wireless Charging Pad+Dock
Main Model Name	RA843
Frequency Range	110~205kHz
Power Operation (Voltage Range)	<input checked="" type="checkbox"/> AC 120V/60Hz <input checked="" type="checkbox"/> Adapter I/P: 100-240Vac, 50/60Hz, 1.5A; O/P: 19Vdc, 3.42A <input type="checkbox"/> By AC Power Cord <input type="checkbox"/> PoE
	<input type="checkbox"/> DC Type <input type="checkbox"/> Battery <input type="checkbox"/> DC Power Supply <input type="checkbox"/> External from USB Cable <input type="checkbox"/> External DC Adapter
	<input type="checkbox"/> Host System
Received Date	Nov 16, 2018
Date of Test	Dec 04, 2018 ~ Dec 07, 2018

*\*All measurement and test data in this report was gathered from production sample identifier: 181116001  
(Assigned by BACL, Taiwan)*

### Objective

This Type approval report is prepared on behalf of *I/O INTERCONNECT INC.* in accordance with Part 2, Subpart J, and Part 15, Subparts A and C of the Federal Communications Commission’s rules.

The objective is to determine the compliance of the EUT with FCC rules, sec 15.203, 15.205, 15.207, 15.209.

### Related Submittal(s)/Grant(s)

FCC Part 15.247 DTS submission with FCC ID: 2ACNORA842

**Test Methodology**

All measurements contained in this report were conducted with ANSI C63.10-2013, American National Standard of Procedures for Compliance Testing of Unlicensed Wireless Devices.

KDB 680106 D01 RF Exposure Wireless Charging Apps v03

**Test Facility**

The Test site used by Bay Area Compliance Laboratories Corp. (Taiwan) to collect test data is located on

70, Lane 169, Sec. 2, Datong Road, Xizhi Dist., New Taipei City 22183, Taiwan, R.O.C.

68-3, Lane 169, Sec. 2, Datong Road, Xizhi Dist., New Taipei City 22183, Taiwan, R.O.C.

Bay Area Compliance Laboratories Corp. (Taiwan) Lab is accredited to ISO 17025 by Taiwan Accreditation Foundation (TAF code: 3180) and the FCC designation No. TW3180 under the FCC 2.948(e) by Mutual Recognition Agreement (MRA) in FCC Test. The facility also complies with the radiated and AC line conducted test site criteria set forth in ANSI C63.10.

The Federal Communications Commission has the reports on file and is listed under FCC Registration No.: 974454. The test site has been approved by the FCC for public use and is listed in the FCC Public Access Link (PAL) database.

## **System Test Configuration**

---

### **Description of Test Configuration**

The system was configured for testing in a typical fashion (as normally used by a typical user).

The device is a wireless charger operation on frequency 110 kHz - 205 kHz.

On the Qi Module, the Tx always detect 3 coils to check status, when the Rx is close, it will start to be pairing, When the pairing is success, Tx will be locked the coil and keeps this status.

Pre scan 3 coils, the worst is middle coils, so middle coils for all test.

### **EUT Exercise Software**

No software was used.

### **Special Accessories**

No special accessory.

### **Equipment Modifications**

No modification was made to the EUT.

**Support Equipment List and Details**

Description	Manufacturer	Model Number	BSMI	FCC ID	S/N
Mobile Phone	SAMSUNG	SM-G930V	N/A	N/A	R38H50YSZ6M
NB	DELL	E6410	N/A	PD98260NGU	10912240367
USB Dongle*3	Kingston	SE9 G2 USB3.0 16G	N/A	N/A	N/A
Monitor	DELL	S2817Q	R43004	DOC	CN-0GD45P- WS200-77B- 092I-A01
Earphone	KINYO	N/A	N/A	N/A	N/A
SD Card	Transcend	Transcend 4GB	N/A	N/A	N/A
Switching Adapter (For ferrite core)	DEE VAN ENTERPRISE CO., LTD.	DSA- 65PFB-19 FUS	N/A	N/A	N/A

**External Cable List and Details**

Cable Description	Length (m)	From	To
USB Cable	0.4	NB	EUT
USB Cable*3	1.2	USB Dongle	EUT
HDMI Cable	1.8	Monitor	EUT
Audio Cable	1.2	Earphone	EUT

### Block Diagram of Test Setup

#### Radiation:

Below 1GHz:

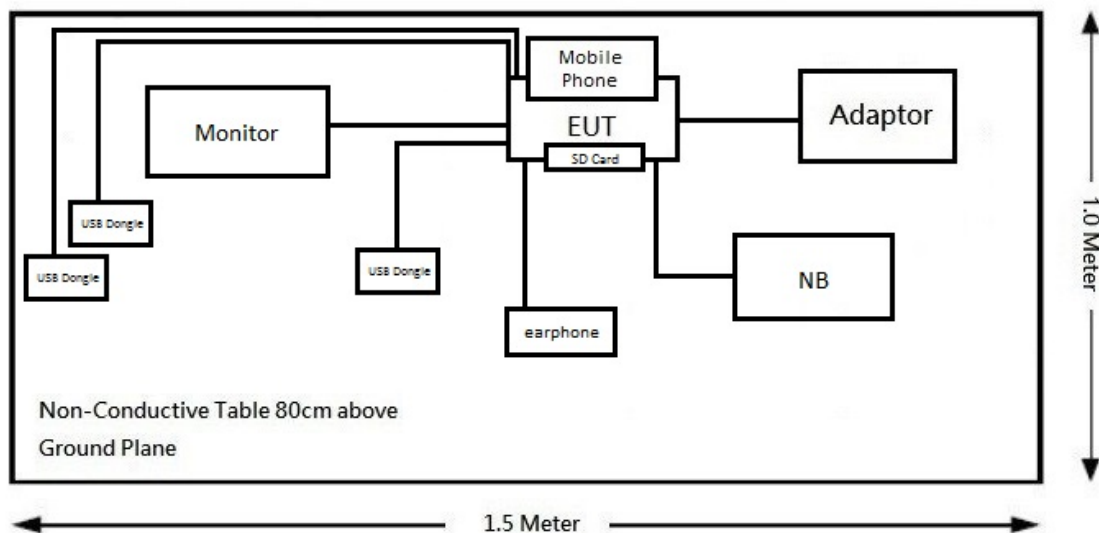

#### Conduction:

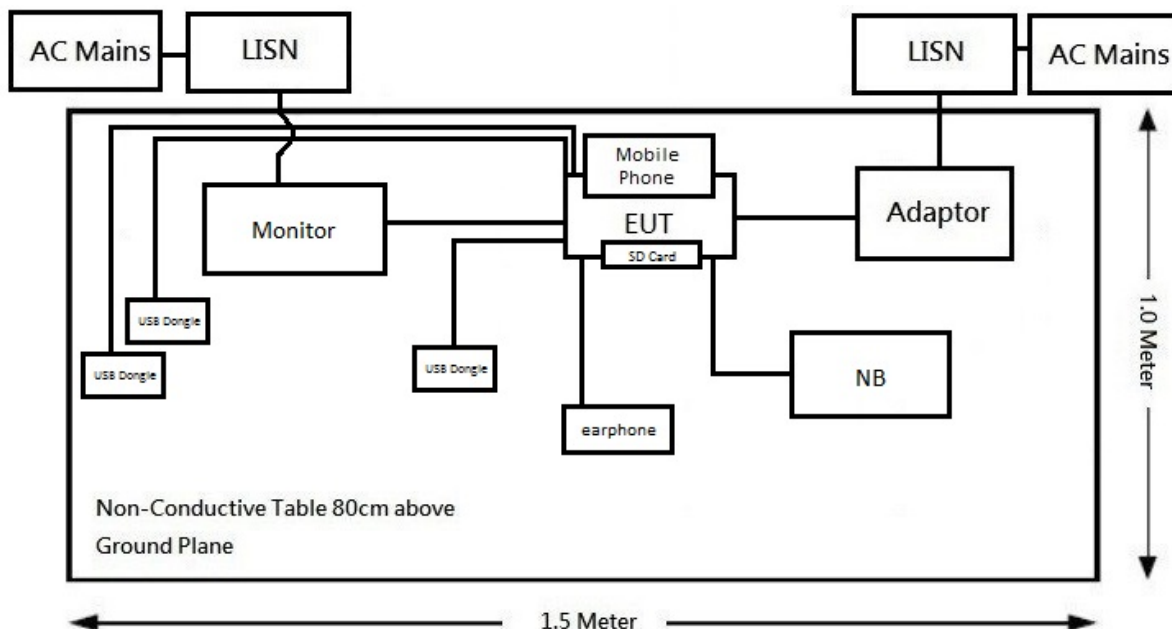



## Summary of Test Results

FCC Rules	Description of Test	Results
FCC§15.203	Antenna Requirement	Compliance
FCC §1.1310, §2.1091	Maximum Permissible Exposure(MPE)	Compliance
FCC§15.207	AC Line Conducted Emissions	Compliance
FCC§15.209, §15.205	Radiated Emissions	Compliance
FCC§15.215 (c)	Emission Bandwidth	Compliance

### Test Equipment List and Details

Description	Manufacturer	Model	Serial Number	Calibration Date	Calibration Due Date
AC Line Conduction Room (CON-A)					
LISN	Rohde & Schwarz	ENV216	101612	2018/02/22	2019/02/21
EMI Test Receiver	Rohde & Schwarz	ESR7	101419	2018/10/23	2019/10/22
Pulse Limiter	Rohde & Schwarz	ESH3Z2	TXZEM104	2018/08/03	2019/08/02
RF Cable	EMEC	EM-CB5D	001	2018/07/02	2019/07/01
Software	AUDIX	E3	V9.150826k	N.C.R	N.C.R
Radiated Room (966-A)					
Bilog Antenna with 6 dB Attenuator	SUNOL SCIENCES & MINI-CIRCUITS	JB6/UNAT-6+	A050115/1554 2_01	2017/12/20	2018/12/19
Active Loop Antenna	ETS-Lindgren	6502	00035796	2018/03/13	2019/03/12
Preamplifier	Sonoma	310N	130602	2018/07/04	2019/07/03
EMI Test Receiver	Rohde & Schwarz	ESR7	101419	2018/10/23	2019/10/22
Spectrum Analyzer	Rohde & Schwarz	FSV40	101435	2018/02/12	2019/02/13
Micro flex Cable	UTIFLEX	FSCM 64639 / (2M)	93D0127	2018/07/31	2019/07/30
Micro flex Cable	UTIFLEX	UFA210A-1-3149-300300	MFR64639 226389-001	2018/11/16	2019/11/15
Micro flex Cable	ROSNOL	K1K50-UP0264-K1K50-450CM	160309-1	2018/03/05	2019/03/04
Micro flex Cable	ROSNOL	K1K50-UP0264-K1K50-80CM	160309-2	2018/01/17	2019/01/16
Turn Table	Champro	TT-2000	060772-T	N.C.R	N.C.R
Antenna Tower	Champro	AM-BS-4500-B	060772-A	N.C.R	N.C.R
Controller	Champro	EM1000	60772	N.C.R	N.C.R
Software	Farad	EZ_EMCC	BACL-03A1	N.C.R	N.C.R

Description	Manufacturer	Model	Serial Number	Calibration Date	Calibration Due Date
RS Room					
Exposure Level Tester	Narda	ELT-400	N-0215	2018/02/22	2019/02/21
B Field Probe	Narda	ELT Probe 100cm <sup>2</sup>	M-0666	2018/02/22	2019/02/21
Isotropic Probe	ETS-Lindgren	HI-6005	00201839	2018/02/22	2019/02/21

*\*Statement of Traceability: BACL Corp. attests that all of the calibrations on the equipment items listed above were traceable to the SI System of Units via the R.O.C. Center for Measurement Standards of the Electronics Testing Center, Taiwan (ETC) or to another internationally recognized National Metrology Institute (NMI), and were compliant with the current Taiwan Accreditation Foundation (TAF) requirements*

---

## **FCC §15.203 – Antenna Requirement**

---

### **Applicable Standard**

According to FCC 15.203

An intentional radiator shall be designed to ensure that no antenna other than that furnished by the responsible party shall be used with the device. The use of a permanently attached antenna or of an antenna that uses a unique coupling to the intentional radiator shall be considered sufficient to comply with the provisions of this section.

### **Antenna Connected Construction**

The EUT has three integrated loop inductive antennas arrangement, which was permanently attached and fulfill the requirement of this section. Please refer to the EUT photos.

**Result:** Compliance.

**FCC §1.1310 & §2.1091 –MAXIMUM PERMISSIBLE EXPOSURE (MPE)**

**Applicable Standard**

According to subpart §1.1310, systems operating under the provisions of this section shall be operated in a manner that ensures that the public is not exposed to radio frequency energy level in excess of the Commission’s guidelines.

Limits for Maximum Permissible Exposure (MPE) (§1.1310, §2.1091)

**Limits for Maximum Permissible Exposure (MPE)**

Frequency range (MHz)	Electric field strength (V/m)	Magnetic field strength (A/m)	Power density (mW/cm <sup>2</sup> )	Averaging time (minutes)
<b>(A) Limits for Occupational/Controlled Exposure</b>				
0.3-3.0	614	1.63	*100	6
3.0-30	1842/f	4.89/f	*900/f <sup>2</sup>	6
30-300	61.4	0.163	1.0	6
300-1,500			f/300	6
1,500-100,000			5	6
<b>(B) Limits for General Population/Uncontrolled Exposure</b>				
0.3-1.34	614	1.63	*100	30
1.34-30	824/f	2.19/f	*180/f <sup>2</sup>	30
30-300	27.5	0.073	0.2	30
300-1,500			f/1500	30
1,500-100,000			1.0	30

f = frequency in MHz

\*= Plane-wave equivalent power density

According with KDB 680106 D01 RF Exposure Wireless Charging Apps v03 clause 3 c)

(c) For devices designed for typical desktop applications, such a wireless charging pads, RF exposure evaluation should be conducted assuming a user separation distance of 15 cm. E and H field strength measurements or numerical modeling may be used to demonstrate compliance. Measurements should be made from all sides and the top of the primary/client pair, with the 15 cm measured from the center of the probe(s) to the edge of the device. Emissions between 100 kHz to 300 kHz should be assessed versus the limits at 300 kHz in Table 1 of Section 1.1310: 614 V/m and 1.63 A/m. A KDB inquiry is required to determine the applicable exposure limits below 100 kHz.

According to 680106 D01 RF Exposure Wireless Charging App v03 clause 5 b)

Inductive wireless power transfer applications with supporting field strength results and meeting all of the following requirements are not required to submit a KDB inquiry for devices approved using SDoC or a PAG for equipment approved using certification to address RF exposure compliance. However, the responsible party is required to keep a copy of the test report in accordance with KDB 865664 D02. A copy of the test report is to be submitted with the application if the device is approved using certification.

- (1) Power transfer frequency is less than 1 MHz..
- (2) Output power from each primary coil is less than or equal to 15 watts.
- (3) The transfer system includes only single primary and secondary coils. This includes charging systems that may have multiple primary coils and clients that are able to detect and allow coupling only between individual pairs of coils.
- (4) Client device is placed directly in contact with the transmitter.
- (5) Mobile exposure conditions only (portable exposure conditions are not covered by this exclusion).
- (6) The aggregate H-field strengths at 15 cm surrounding the device and 20 cm above the top surface from all simultaneous transmitting coils are demonstrated to be less than 50% of the MPE limit.

**EUT Setup**

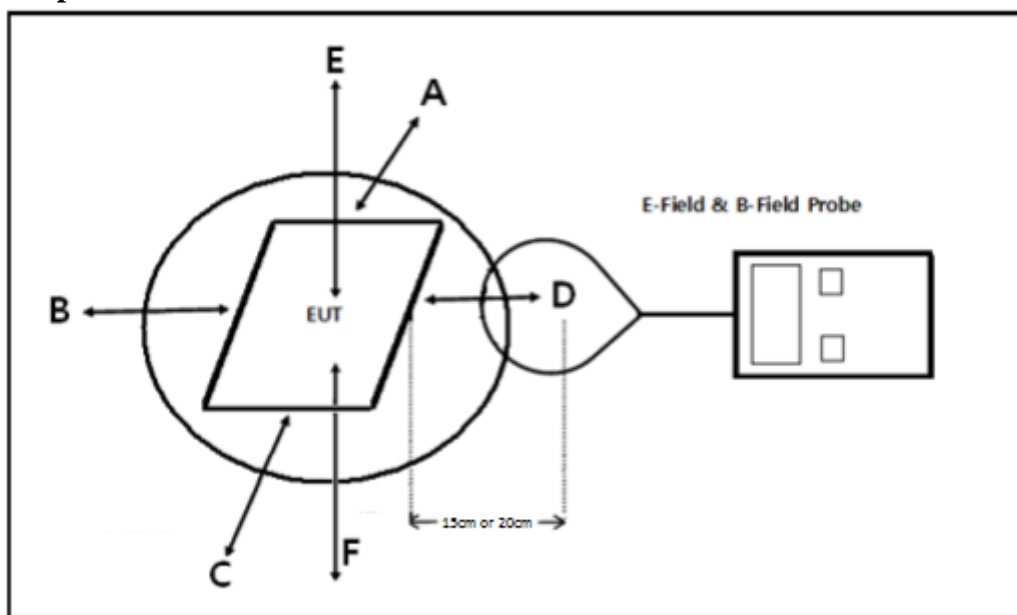

**Test Result**

- (1) Power transfer frequency is less than 1 MHz.  
Yes, the transfer frequency is below 110 – 205 kHz.
- (2) Output power from each primary coil is less than 15 watts.  
Yes, the device has three coils. Only one coil can be operated at a time and the transmit power is less than 5 watts.
- (3) The transfer system includes only single primary and secondary coils. This includes charging systems that may have multiple primary coils and clients that are able to detect and allow coupling only between individual pairs of coils.  
The transfer system including a charging system with only single primary coils is to detect and allow only between individual of coils.
- (4) Client device is placed directly in contact with the transmitter.

Yes, client device is placed directly in contact with the transmitter.

- (5) Mobile exposure conditions only (portable exposure conditions are not covered by this exclusion).

Yes, mobile exposure conditions only

- (6) The aggregate H-field strengths at 15 cm surrounding the device and 20 cm above the top surface from all simultaneous transmitting coils are demonstrated to be less than 50% of the MPE limit.

Yes, the test result for H and E-field strength less than 50% of the MPE limit.

Please refer the results below.

FCC

**E-Filed Strength**

Frequency Range (kHz)	Position A (V/m)	Position B (V/m)	Position C (V/m)	Position D (V/m)	Position E (V/m)	Position F (V/m)	50% Limit Test (V/m)	Limit Test (V/m)
110-205	0.987	0.658	0.924	1.648	0.974	0.863	307	614

Note: Test with 15cm distance from the center of the probe(s) to the edge of the device, distance 20cm used for top surface test.

**H-Filed Strength**

Frequency Range (kHz)	Position A (A/m)	Position B (A/m)	Position C (A/m)	Position D (A/m)	Position E (A/m)	Position F (A/m)	50% Limit Test (A/m)	Limit Test (A/m)
110-205	0.183	0.182	0.185	0.192	0.186	0.185	0.815	1.63

Note: Test with 15cm distance from the center of the probe(s) to the edge of the device, distance 20cm used for top surface test.

## **FCC §15.207 – AC Line Conducted Emissions**

### **Applicable Standard**

According to FCC §15.207 Conducted limits:

For an intentional radiator that is designed to be connected to the public utility (AC) power line, the radio frequency voltage that is conducted back onto the AC power line on any frequency or frequencies within the band 150 kHz to 30 MHz shall not exceed the limits in the following table, as measured using a 50 μH/50 ohms line impedance stabilization network (LISN). Compliance with the provisions of this paragraph shall be based on the measurement of the radio frequency voltage between each power line and ground at the power terminal. The lower limit applies at the boundary between the frequencies ranges.

Frequency of Emission (MHz)	Conducted Limit (dBuV)	
	Quasi-Peak	Average
0.15-0.5	66 to 56 <sup>Note 1</sup>	56 to 46 <sup>Note 2</sup>
0.5-5	56	46
5-30	60	50

*Note 1: Decreases with the logarithm of the frequency.*

*Note 2: A linear average detector is required*

### **Measurement Uncertainty**

Input quantities to be considered for conducted disturbance measurements maybe receiver reading, attenuation of the connection between LISN/ISN and receiver, LISN/ISN voltage division factor, LISN/ISN VDF frequency interpolation and receiver related input quantities, etc.

Based on CISPR 16-4-2:2011, the expended combined standard uncertainty of conducted disturbance test at Bay Area Compliance Laboratories Corp. (Taiwan) is shown as below. And the uncertainty will not be taken into consideration for the test data recorded in the report.

Port	Expanded Measurement uncertainty
AC Mains	2.71 dB (k=2, 95% level of confidence)



**EUT Setup**

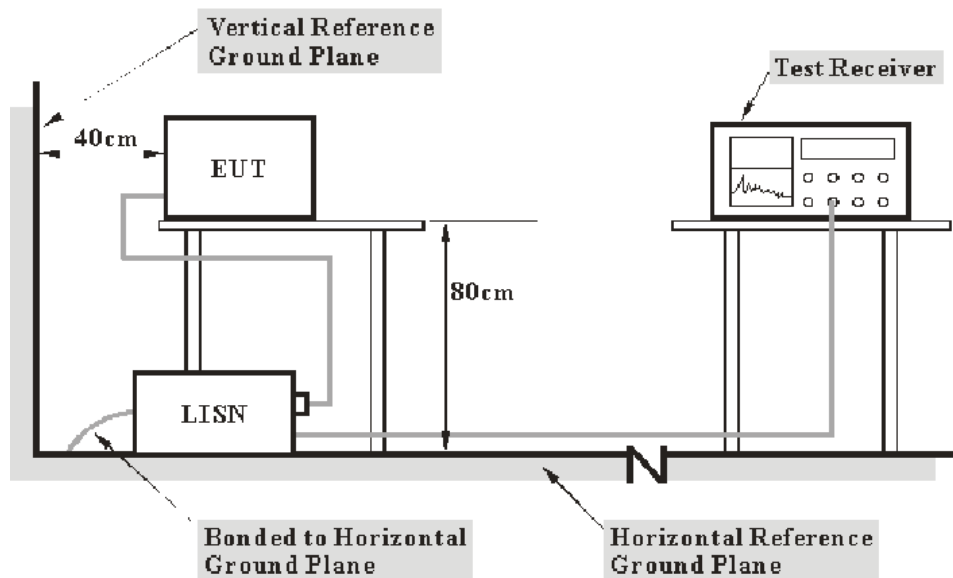

- Note:**
1. Support units were connected to second LISN.
  2. Both of LISNs (AMN) 80 cm from EUT and at the least 80 cm from other units and other metal planes support units.

The setup of EUT is according with per ANSI C63.10-2013 measurement procedure. The specification used was with the FCC Part 15.207 limits.

The external I/O cables were draped along the test table and formed a bundle 30 to 40 cm long in the middle.

The spacing between the peripherals was 10 cm.

**EMI Test Receiver Setup**

The EMI test receiver was set to investigate the spectrum from 150 kHz to 30 MHz.

During the conducted emission test, the EMI test receiver was set with the following configurations

Frequency Range	IF B/W
150 kHz – 30 MHz	9 kHz

**Test Procedure**

During the conducted emission test, the adapter was connected to the outlet of the LISN.

Maximizing procedure was performed on the six (6) highest emissions of the EUT.

All data was recorded in the Quasi-peak and average detection mode.

According FCC publication number 174176,for a device with a permanent antenna operating at or below 30 MHz, the measurements done with a suitable dummy load, in lieu of the permanent antenna under the following conditions: (1) perform the AC line conducted tests with the permanent antenna to determine compliance with the Section 15.207 limits outside the transmitter's fundamental emission band; (2) retest with a dummy load in lieu of the permanent antenna to determine compliance with the Section 15.207 limits within the transmitter's fundamental emission band.

**Factor & Over Limit Calculation**

The factor is calculated by adding LISN/ISN VDF (Voltage Division Factor), Cable Loss and Transient Limiter Attenuation. The basic equation is as follows:

$$\text{Factor} = \text{LISN VDF} + \text{Cable Loss} + \text{Transient Limiter Attenuation}$$

The “Over Limit” column of the following data tables indicates the degree of compliance with the applicable limit. For example, an over limit of -7 dB means the emission is 7 dB below the limit. The equation for Over Limit calculation is as follows:

$$\text{Over Limit} = \text{Level} - \text{Limit Line}$$

**Test Results Summary**

According to the recorded data in following table, the EUT complied with the FCC Part 15.207.

**Environmental Conditions**

<b>Temperature:</b>	25 °C
<b>Relative Humidity:</b>	55 %
<b>ATM Pressure:</b>	1010 hPa

*The testing was performed by Tom Hsu on 2018-12-06.*

**Test Results**

Please refer to the following plots and tables.

Test Mode: Transmitting

**Main: AC 120V/60 Hz, Line**

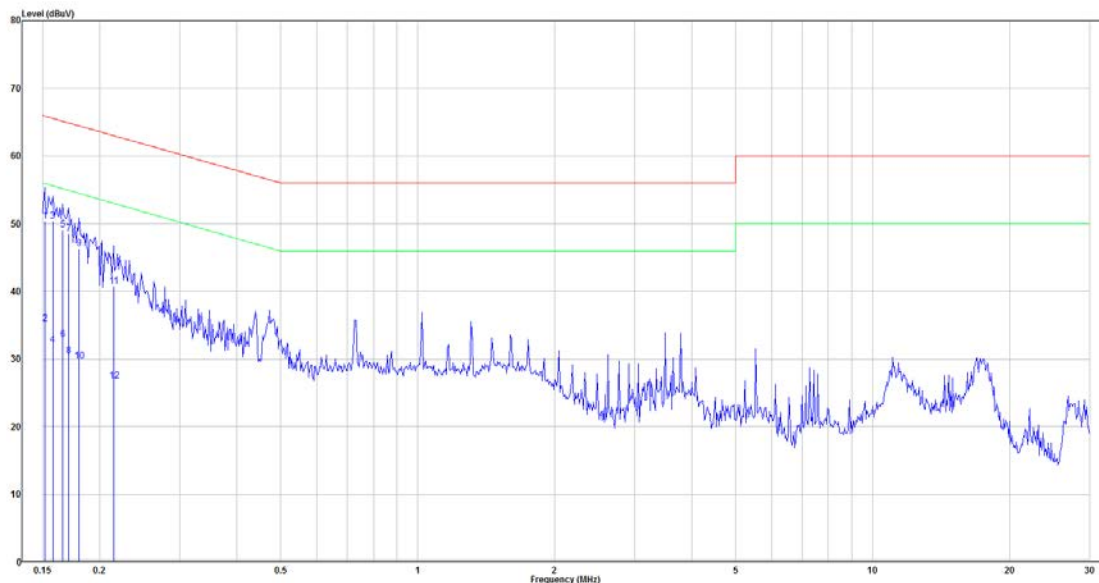

No.	Frequency (MHz)	Reading (dBµV)	Correct Factor(dB)	Result (dBµV)	Limit (dBµV)	Over limit (dB)	Remark
1	0.152	30.87	19.45	50.32	65.92	-15.60	QP
2	0.152	15.79	19.45	35.24	55.92	-20.68	Average
3	0.158	30.87	19.45	50.33	65.59	-15.26	QP
4	0.158	12.57	19.45	32.02	55.59	-23.57	Average
5	0.166	29.61	19.45	49.06	65.17	-16.11	QP
6	0.166	13.43	19.45	32.88	55.17	-22.29	Average
7	0.171	29.04	19.45	48.50	64.92	-16.43	QP
8	0.171	10.96	19.45	30.41	54.92	-24.51	Average
9	0.180	26.89	19.46	46.34	64.47	-18.13	QP
10	0.180	10.14	19.46	29.60	54.47	-24.87	Average
11	0.215	21.28	19.46	40.74	63.02	-22.28	QP
12	0.215	7.27	19.46	26.73	53.02	-26.29	Average

Note:

Level = Read Level + Factor

Over Limit = Level – Limit Line

Factor = (LISN, ISN, PLC or current probe) Factor + Cable Loss + Attenuator

**AC 120V/60 Hz, Neutral**

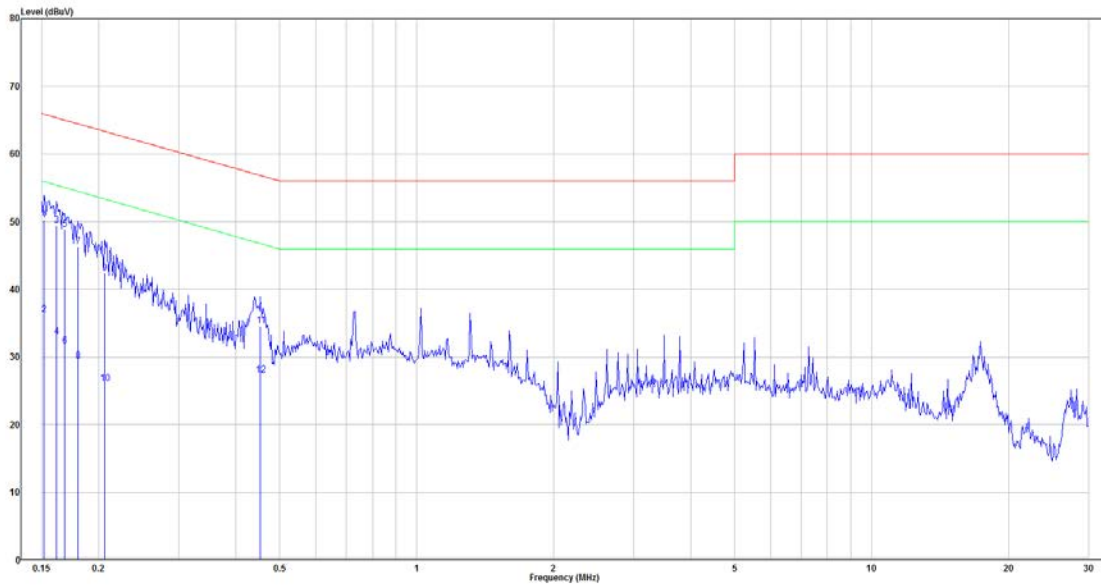

No.	Frequency (MHz)	Reading (dBµV)	Correct Factor(dB)	Result (dBµV)	Limit (dBµV)	Over limit (dB)	Remark
1	0.152	30.78	19.44	50.22	65.92	-15.70	QP
2	0.152	16.78	19.44	36.22	55.92	-19.70	Average
3	0.162	29.99	19.45	49.44	65.38	-15.94	QP
4	0.162	13.55	19.45	33.00	55.38	-22.38	Average
5	0.168	29.45	19.45	48.90	65.05	-16.15	QP
6	0.168	12.17	19.45	31.61	55.05	-23.43	Average
7	0.180	26.86	19.45	46.32	64.47	-18.15	QP
8	0.180	10.00	19.45	29.45	54.47	-25.02	Average
9	0.206	22.95	19.46	42.41	63.35	-20.95	QP
10	0.206	6.53	19.46	25.99	53.35	-27.36	Average
11	0.454	15.19	19.46	34.66	56.81	-22.15	QP
12	0.454	7.87	19.46	27.33	46.81	-19.48	Average

Note:

Level = Read Level + Factor

Over Limit = Level – Limit Line

Factor = (LISN, ISN, PLC or current probe) Factor + Cable Loss + Attenuator

**FCC §15.205 & §15.209 – Radiated Emissions**

**Applicable Standard**

As per FCC §15.35(d): Unless otherwise specified, on any frequency or frequencies above 1000 MHz, the radiated emission limits are based on the use of measurement instrumentation employing an average detector function. Unless otherwise specified, measurements above 1000 MHz shall be performed using a minimum resolution bandwidth of 1 MHz.

As Per FCC §15.205(a) except as show in paragraph (d) of this section, only spurious emissions are permitted in any of the frequency bands listed below:

MHz	MHz	MHz	GHz
0.090 – 0.110	16.42 – 16.423	960 – 1240	4. 5 – 5. 15
0.495 – 0.505	16.69475 – 16.69525	1300 – 1427	5. 35 – 5. 46
2.1735 – 2.1905	25.5 – 25.67	1435 – 1626.5	7.25 – 7.75
4.125 – 4.128	37.5 – 38.25	1645.5 – 1646.5	8.025 – 8.5
4.17725 – 4.17775	73 – 74.6	1660 – 1710	9.0 – 9.2
4.20725 – 4.20775	74.8 – 75.2	1718.8 – 1722.2	9.3 – 9.5
6.215 – 6.218	108 – 121.94	2200 – 2300	10.6 – 12.7
6.26775 – 6.26825	123 – 138	2310 – 2390	13.25 – 13.4
6.31175 – 6.31225	149.9 – 150.05	2483.5 – 2500	14.47 – 14.5
8.291 – 8.294	156.52475 – 156.52525	2690 – 2900	15.35 – 16.2
8.362 – 8.366	156.7 – 156.9	3260 – 3267	17.7 – 21.4
8.37625 – 8.38675	162.0125 – 167.17	3.332 – 3.339	22.01 – 23.12
8.41425 – 8.41475	167.72 – 173.2	3 3458 – 3 358	23.6 – 24.0
12.29 – 12.293	240 – 285	3.600 – 4.400	31.2 – 31.8
12.51975 – 12.52025	322 – 335.4		36.43 – 36.5
12.57675 – 12.57725	399.9 – 410		Above 38.6
13.36 – 13.41	608 – 614		

As per FCC §15.209(a): Except as provided elsewhere in this Subpart, the emissions from an intentional radiator shall not exceed the field strength levels specified in the following table:

Frequency (MHz)	Field Strength (micro volts/meter)	Measurement Distance (meters)
0.009 - 0.490	2400/F(kHz)	300
0.490 - 1.705	24000/F(kHz)	30
1.705 - 30.0	30	30
30 - 88	100**	3
88 - 216	150**	3
216 - 960	200**	3
Above 960	500	3

\*\* Except as provided in paragraph (g), fundamental emissions from intentional radiators operating under this Section shall not be located in the frequency bands 54-72 MHz, 76-88 MHz, 174-216 MHz or 470-806 MHz. However, operation within these frequency bands is permitted under other sections of this Part, e.g., Sections 15.231 and 15.241.

### Measurement Uncertainty

All measurements involve certain levels of uncertainties, especially in field of EMC. The factors contributing to uncertainties are spectrum analyzer, cable loss, antenna factor calibration, antenna directivity, antenna factor variation with height, antenna phase center variation, antenna factor frequency interpolation, measurement distance variation, site imperfections, mismatch (average), and system repeatability.

Based on CISPR 16-4-2:2011, the expended combined standard uncertainty of radiation emissions at Bay Area Compliance Laboratories Corp. (Taiwan) is shown in below table. And the uncertainty will not be taken into consideration for the test data recorded in the report.

Frequency	Measurement uncertainty
9 kHz~30MHz	3.77 dB (k=2, 95% level of confidence)
30MHz~200MHz	3.75 dB (k=2, 95% level of confidence)
200MHz~1GHz	4.21 dB (k=2, 95% level of confidence)

### EUT Setup

9 kHz- 30 MHz:

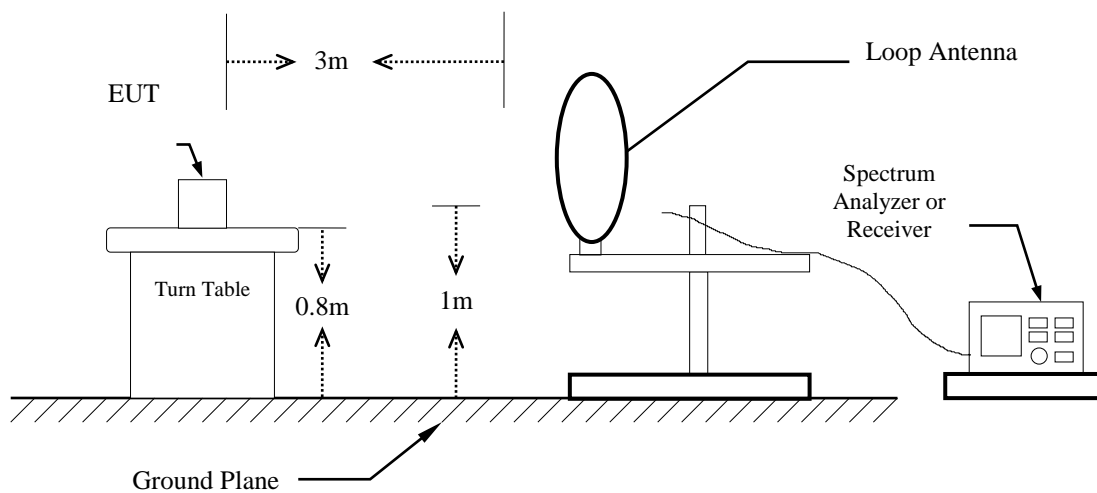

30 MHz – 1 GHz:

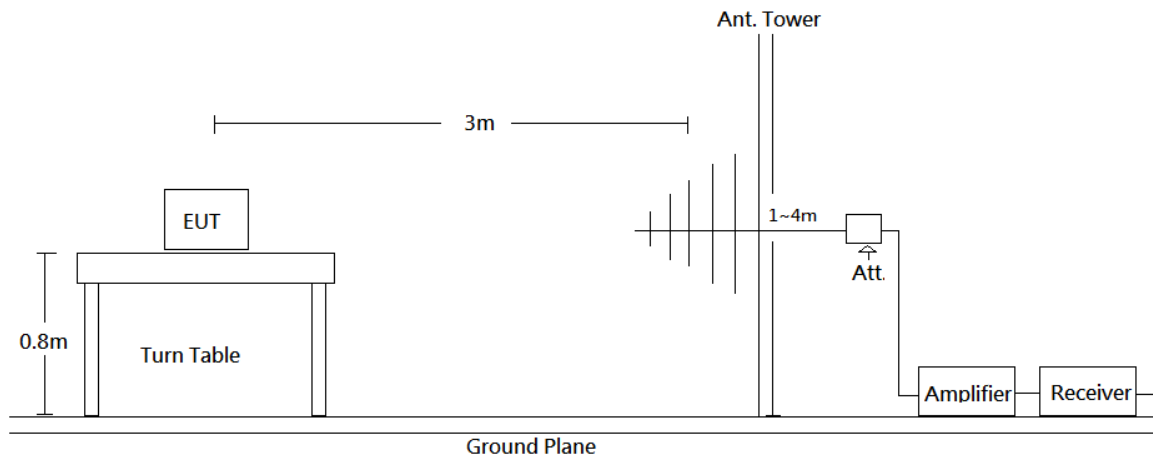

The radiated emission tests were performed in the 3 meters chamber test site, using the setup accordance with the ANSI C63.10-2013. The specification used was the FCC 15.209 and FCC 15.205 limits.

The spacing between the peripherals was 10 cm.

The adapter was connected to 120VAC/60Hz power source.

**EMI Test Receiver Setup**

The system was investigated from 9 kHz to 1 GHz.

During the radiated emission test, the EMI test receiver was set with the following configurations

Frequency Range	RBW	RBW Video B/W	Detector
9 kHz –150 kHz	200 Hz	1kHz	QP
150 kHz – 30 MHz	9 kHz	30 kHz	QP
30MHz – 1000 MHz	120 kHz	300 kHz	QP

Note: The frequency bands 9-90 kHz and 110-490 kHz, the testing is based on average detector.

If the maximized peak measured value complies with the limit, then it is unnecessary to perform an QP/Average measurement

**Test Procedure**

Maximizing procedure was performed on the highest emissions to ensure that the EUT complied with all installation combinations.

The EUT is set 3 meter away from the testing antenna, which is varied from 1-4 meter, and the EUT is placed on a turntable, which is 0.8 meter above ground plane, the table shall be rotated for 360 degrees to find out the highest emission. The receiving antenna should be changed the polarization both of horizontal and vertical.

### Correct Factor & Margin Calculation

The Correct Factor is calculated by adding the Antenna Factor and Cable Loss, and subtracting the Amplifier Gain from the Meter Reading. The basic equation is as follows:

$$\text{Correct Factor} = \text{Antenna Factor} + \text{Cable Loss} - \text{Amplifier Gain} + \text{Attenuator}$$

The “Margin” column of the following data tables indicates the degree of compliance with the applicable limit. For example, a margin of 7 dB means the emission is 7 dB below the limit. The equation for margin calculation is as follows:

$$\text{Margin} = \text{Limit} - \text{Result}$$

### Test Results Summary

According to the data in the following table, the EUT complied with the FCC §15.209.

#### Environmental Conditions

<b>Temperature:</b>	25 °C
<b>Relative Humidity:</b>	60 %
<b>ATM Pressure:</b>	1010 hPa

*The testing was performed by Tom Hsu on 2018-12-05.*



### Test Results

Mode: Transmitting

#### Field strength of fundamental

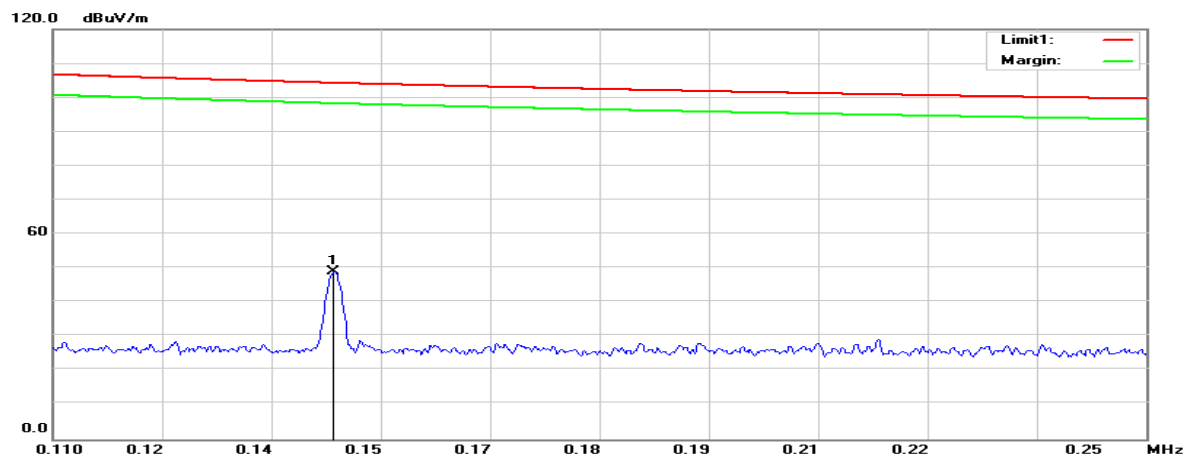

#### 9 kHz – 30MHz

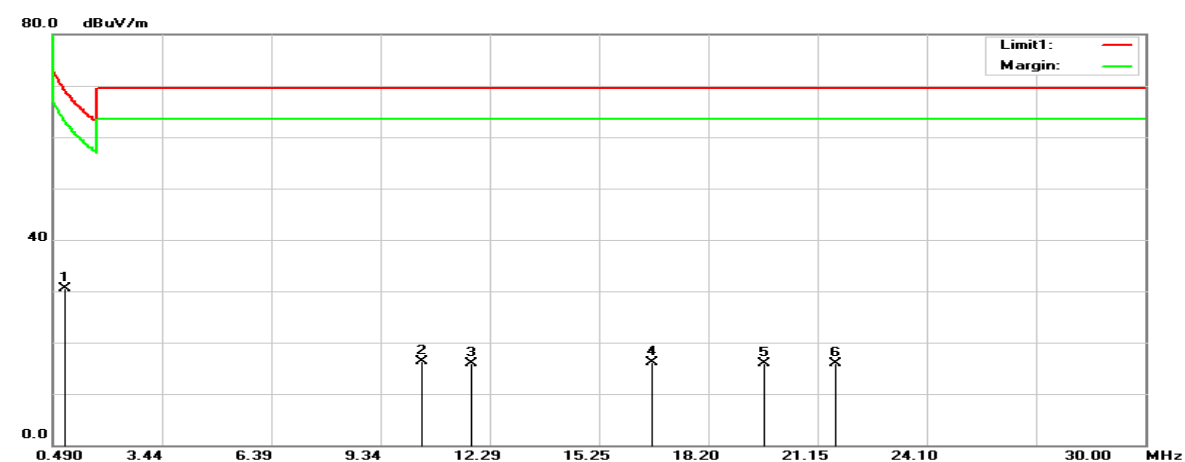
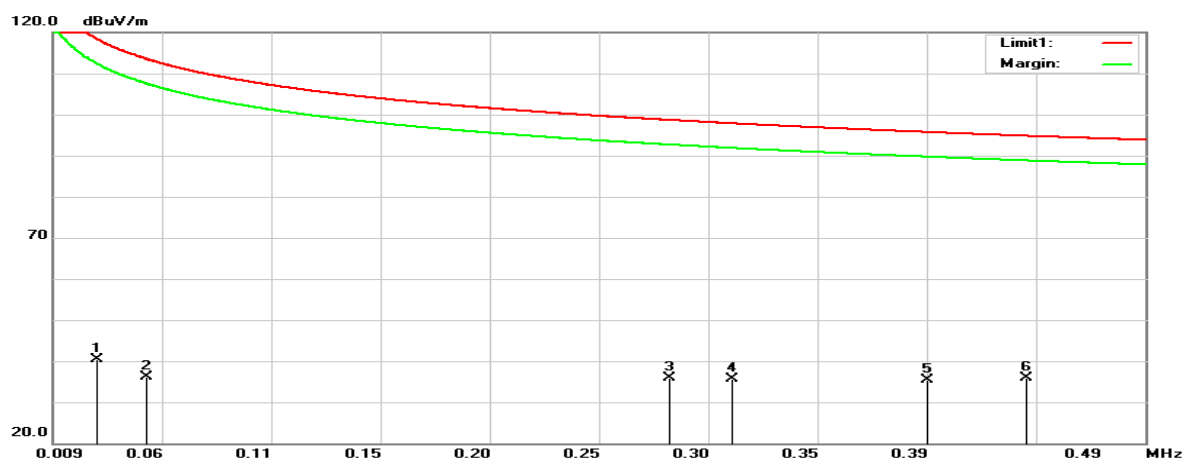

Frequency	Reading	Correct	Result	Limit	Margin	Height	Degree	Remark
(MHz)	(dBμV)	Factor(dB/m)	(dBμV/m)	(dBμV/m)	(dB)	(cm)	( ° )	
0.0286	25.92	14.35	40.27	118.46	-78.19	100	254	AVG
0.0504	23.03	13.01	36.04	113.54	-77.50	100	212	AVG
*0.1460	36.32	12.65	48.97	104.31	-55.34	100	339	AVG
0.2807	23.91	11.93	35.84	98.64	-62.80	100	86	AVG
0.3080	23.64	11.95	35.59	97.83	-62.24	100	246	AVG
0.3941	23.50	11.90	35.40	95.69	-60.29	100	281	AVG
0.4375	24.05	11.88	35.93	94.78	-58.85	100	6	AVG
0.8146	18.82	11.67	30.49	69.40	-38.91	100	134	QP
10.4644	4.71	11.68	16.39	69.50	-53.11	100	222	QP
11.8218	4.29	11.60	15.89	69.50	-53.61	100	326	QP
16.6615	4.86	11.32	16.18	69.50	-53.32	100	254	QP
19.7305	4.77	11.15	15.92	69.50	-53.58	100	213	QP
21.6192	5.13	10.83	15.96	69.50	-53.54	100	113	QP

Note:

Result = Reading + Correct Factor

Margin = Result - Limit

Correct Factor = Antenna Factor + Cable Loss - Amplifier Gain + Attenuator

“\*” Means Fundamental frequency

Limit calculation: Limit at specified distance + 40log (300/3) = Limit + 80 dB for up to 0.49 MHz

Limit at specified distance + 40log (30/3) = Limit + 40 dB for above 0.49 MHz up to 1.075 MHz

According to §15.209 (d), the measurements were tested by using Quasi peak detector except for the frequency bands 9 – 90 kHz, 110 – 490 kHz and above 1 GHz in these three bands on measurements employing an average detector.

Emissions more than 20dB below the limit are not recorded.

30 MHz - 1 GHz / Horizontal



Frequency	Reading	Correct	Result	Limit	Margin	Height	Degree	Remark
(MHz)	(dB $\mu$ V)	Factor(dB/m)	(dB $\mu$ V/m)	(dB $\mu$ V/m)	(dB)	(cm)	( $^{\circ}$ )	
56.1900	42.49	-16.34	26.15	40.00	-13.85	100	28	QP
206.5400	41.58	-10.26	31.32	43.50	-12.18	100	35	QP
246.3100	44.42	-10.22	34.20	46.00	-11.80	100	27	QP
295.7800	38.20	-8.00	30.20	46.00	-15.80	100	276	QP
696.3900	29.94	-2.28	27.66	46.00	-18.34	100	356	QP
917.5500	28.28	1.15	29.43	46.00	-16.57	100	3	QP

Note:

Result = Reading + Correct Factor

Margin = Result - Limit

Correct Factor = Antenna Factor + Cable Loss - Amplifier Gain + Attenuator

**Vertical**

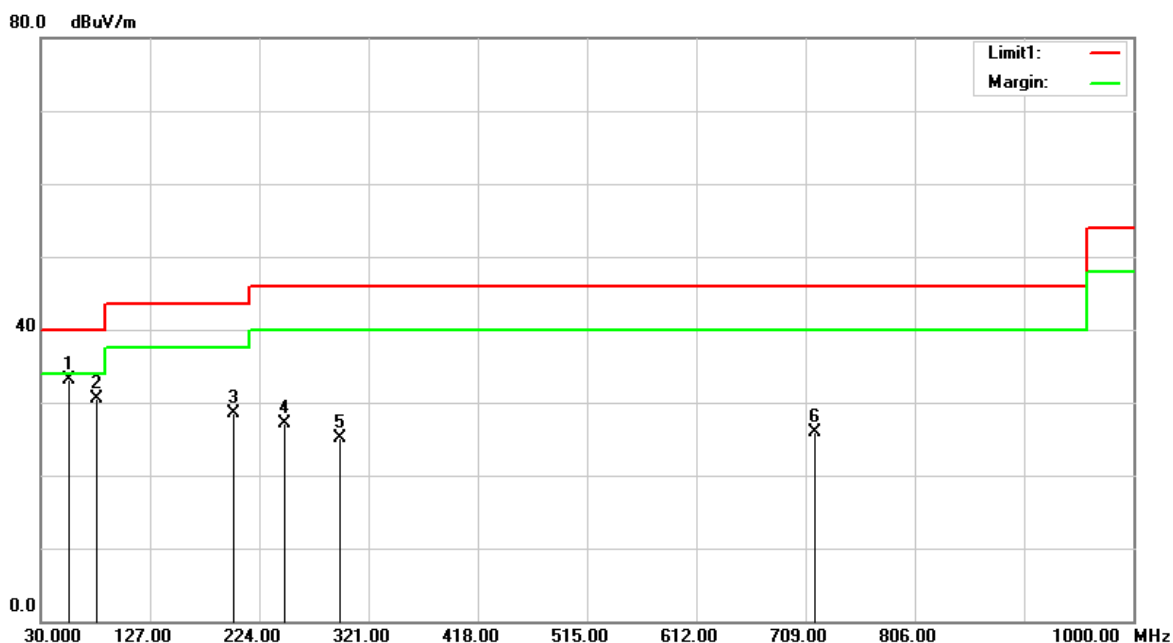

Frequency	Reading	Correct	Result	Limit	Margin	Height	Degree	Remark
(MHz)	(dB $\mu$ V)	Factor(dB/m)	(dB $\mu$ V/m)	(dB $\mu$ V/m)	(dB)	(cm)	( ° )	
55.2200	49.54	-16.51	33.03	40.00	-6.97	100	155	QP
79.4700	46.50	-15.93	30.57	40.00	-9.43	100	25	QP
200.7200	37.98	-9.53	28.45	43.50	-15.05	100	356	QP
246.3100	38.02	-10.92	27.10	46.00	-18.90	100	192	QP
295.7800	33.82	-8.74	25.08	46.00	-20.92	100	22	QP
716.7600	29.05	-3.13	25.92	46.00	-20.08	100	311	QP

Note:

Result = Reading + Correct Factor

Margin = Result - Limit

Correct Factor = Antenna Factor + Cable Loss - Amplifier Gain + Attenuator

Emissions more than 20dB below the limit are not recorded.

**\*\*\*\*\* END OF REPORT \*\*\*\*\***