



FCC PART 15C TEST REPORT

For

I/O INTERCONNECT INC.

5F, No.19-3, Sanchong Rd., Nangang District, Taipei 115, Taiwan

FCC ID: 2ACNORA842

Report Type Original Report	Product Type: DataSav™
Report Producer : <u>Jane Lee</u> <i>Jane Lee</i>	
Report Number : <u>RXZ1803009-00C</u>	
Report Date : <u>2018-04-02</u>	
Reviewed By: <u>Jerry Chang</u> <i>Jerry Chang</i>	
Prepared By: Bay Area Compliance Laboratories Corp.(Taiwan) 70, Lane 169, Sec. 2, Datong Road, Xizhi Dist., New Taipei City 22183, Taiwan, R.O.C. Tel: +886 (2)2647 6898 Fax: +886 (2) 2647 6895 www.bacl.com.tw	

Note: This test report is prepared for the customer shown above and for the device described herein. It may not be duplicated or used in part without prior written consent from Bay Area Compliance Laboratories Corp. (Taiwan)

Revision History

Revision	No.	Report Number	Issue Date	Description	Author/ Revised by
1.0	RXZ1803009	RXZ1803009-00C	2018.04.02	Original Report	Jane

TABLE OF CONTENTS

General Information	4
Product Description for Equipment under Test (EUT)	4
Objective	4
Related Submittal(s)/Grant(s).....	4
Test Methodology	4
Test Facility.....	5
System Test Configuration	6
Description of Test Configuration.....	6
EUT Exercise Software.....	6
Special Accessories	6
Equipment Modifications.....	6
Support Equipment List and Details	6
External Cable List and Details.....	6
Block Diagram of Test Setup	7
Summary of Test Results	8
FCC §15.203 –ANTENNA REQUIREMENT	9
Applicable Standard	9
Antenna Connected Construction.....	9
FCC §1.1307 & 1.1310 – RF EXPOSURE	10
Applicable Standard	10
EUT Setup.....	11
FCC §15.207 – AC Line Conducted Emissions	13
Applicable Standard	13
Measurement Uncertainty	13
EUT Setup.....	14
EMI Test Receiver Setup	14
Test Procedure.....	15
Test Equipment List and Details	15
Factor & Over Limit Calculation	16
Test Results Summary.....	16
Environmental Conditions.....	16
FCC §15.205 & §15.209 –Radiated Emissions	19
Applicable Standard	19
Measurement Uncertainty	20
EUT Setup.....	21
EMI Test Receiver Setup	22
Test Procedure.....	22
Test Equipment List and Details	23
Correct Factor & Margin Calculation.....	24
Test Results Summary.....	24
Environmental Conditions.....	24
FCC§15.215(c) –Emission Bandwidth	29
Applicable Standard	29
Test Procedure.....	29
Test Equipment List and Details	30
Test Environmental Conditions.....	30

General Information

Product Description for Equipment under Test (EUT)

Applicant:	I/O INTERCONNECT INC. 5F, No.19-3, Sanchong Rd., Nangang District, Taipei 115, Taiwan
Manufacturer:	I/O INTERCONNECT INC. 5F, No.19-3, Sanchong Rd., Nangang District, Taipei 115, Taiwan
Product:	DataSav™
Model:	RA842
Trade Name:	MediaGear
Highest Operating Frequency:	110~205kHz
Voltage Range:	Adapter: I/P: 100-240Vac, 50/60Hz, 0.6A O/P: 5Vdc, 3.0A
Date of Test:	Mar 19, 2018 ~ Apr 02, 2018

**All measurement and test data in this report was gathered from production sample identifier: 1803009
(Assigned by BACL, Taiwan) The EUT supplied by the applicant was received on 2018-03-19*

Objective

This Type approval report is prepared on behalf of *I/O INTERCONNECT INC.* in accordance with Part 2, Subpart J, and Part 15, Subparts A and C of the Federal Communications Commission's rules.

The objective is to determine the compliance of the EUT with FCC rules, sec 15.203, 15.205, 15.207, 15.209.

Related Submittal(s)/Grant(s)

FCC Part 15.247 DTS submission with FCC ID: 2ACNORA842

Test Methodology

All measurements contained in this report were conducted with ANSI C63.10-2013, American National Standard of Procedures for Compliance Testing of Unlicensed Wireless Devices.

KDB 680106 D01 RF Exposure Wireless Charging Apps v02

Test Facility

The Test site used by Bay Area Compliance Laboratories Corp. (Taiwan) to collect test data is located on

70, Lane 169, Sec. 2, Datong Road, Xizhi Dist., New Taipei City 22183, Taiwan, R.O.C.

68-3, Lane 169, Sec. 2, Datong Road, Xizhi Dist., New Taipei City 22183, Taiwan, R.O.C.

Bay Area Compliance Laboratories Corp. (Taiwan) Lab is accredited to ISO 17025 by Taiwan Accreditation Foundation (TAF code: 3180) and the FCC designation No. TW3180 under the FCC 2.948(e) by Mutual Recognition Agreement (MRA) in FCC Test. The facility also complies with the radiated and AC line conducted test site criteria set forth in ANSI C63.10.

The Federal Communications Commission has the reports on file and is listed under FCC Registration No.: 974454. The test site has been approved by the FCC for public use and is listed in the FCC Public Access Link (PAL) database.

System Test Configuration

Description of Test Configuration

The system was configured for testing in a typical fashion (as normally used by a typical user).

EUT Exercise Software

No software was used.

Special Accessories

No special accessory.

Equipment Modifications

No modification was made to the EUT.

Support Equipment List and Details

Description	Manufacturer	Model Number	BSMI	FCC ID	S/N
NB	DELL	E6410	N/A	N/A	PD98260N GU
Mobile	SAMSUNG	/	/	/	/

External Cable List and Details

Description	Shielded Type	Ferrite Core	Length
Micro USB Cable	1.5	NB	EUT

Block Diagram of Test Setup

Radiation:

Below 1GHz:

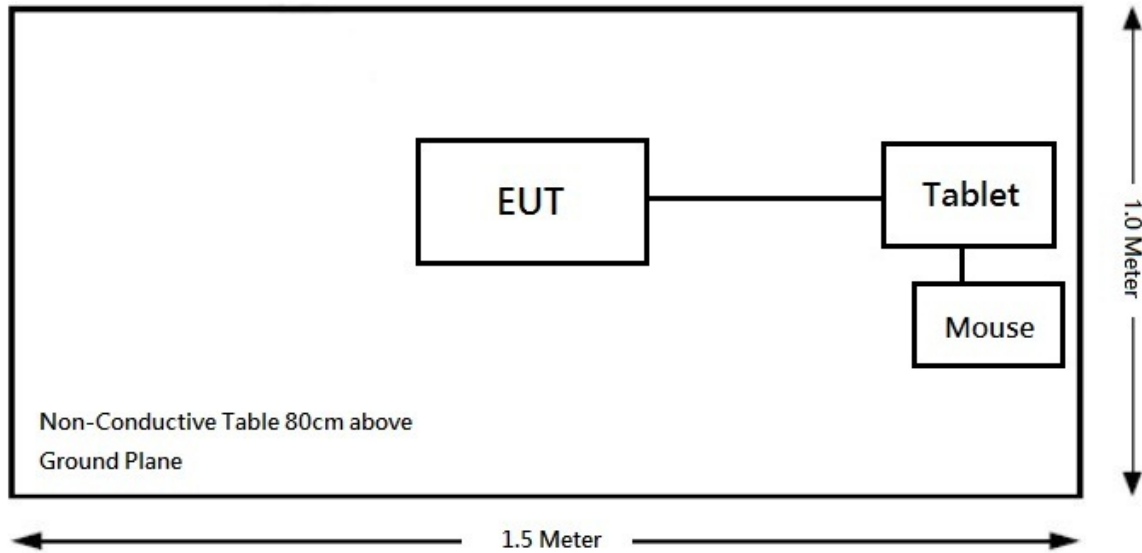

Conduction:

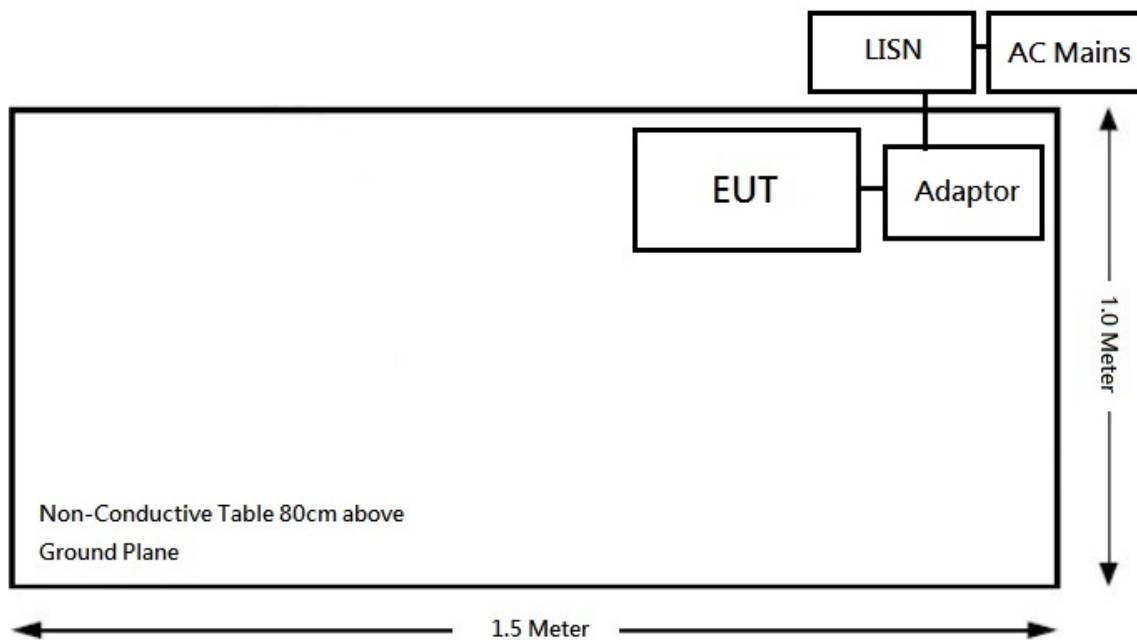

Summary of Test Results

FCC Rules	Description of Test	Results
FCC§15.203	Antenna Requirement	Compliance
FCC§1.1307, §1.1310	RF Exposure	Compliance
FCC§15.207	AC Line Conducted Emissions	Compliance
FCC§15.209, §15.205	Radiated Emissions	Compliance
FCC§15.215 (c)	Emission Bandwidth	Compliance

FCC §15.203 –ANTENNA REQUIREMENT

Applicable Standard

According to FCC 15.203

An intentional radiator shall be designed to ensure that no antenna other than that furnished by the responsible party shall be used with the device. The use of a permanently attached antenna or of an antenna that uses a unique coupling to the intentional radiator shall be considered sufficient to comply with the provisions of this section.

Antenna Connected Construction

The EUT has one integrated loop inductive antenna arrangement, which was permanently attached and fulfill the requirement of this section. Please refer to the EUT photos.

Result: Compliance.

FCC §1.1307 & 1.1310 – RF EXPOSURE

Applicable Standard

FCC §1.1307 & 1.1310

According to the item 5.2 of KDB 680106 D01 RF Exposure Wireless Charging Apps v02:

Inductive wireless power transfer applications that meet all of the following requirements are excluded from submitting an RF evaluation.

- a) Power transfer frequency is less than 1 MHz.
- b) Output power from each primary coil is less than 5 watts.
- c) The transfer system includes only single primary and secondary coils. This includes charging systems that may have multiple primary coils and clients that are able to detect and allow coupling only between individual pairs of coils.
- d) Client device is inserted in or placed directly in contact with the transmitter.
- e) The maximum coupling surface area of the transmit (charging) device is between 60 cm² and 400 cm².
- f) Aggregate leakage fields at 10 cm surrounding the device from all simultaneous transmitting coils are demonstrated to be less than 30% of the MPE limit.

Limits for Maximum Permissible Exposure (MPE)

Frequency range (MHz)	Electric field strength (V/m)	Magnetic field strength (A/m)	Power density (mW/cm ²)	Averaging time (minutes)
(A) Limits for Occupational/Controlled Exposure				
0.3-3.0	614	1.63	*100	6
3.0-30	1842/f	4.89/f	*900/f ²	6
30-300	61.4	0.163	1.0	6
300-1,500			f/300	6
1,500-100,000			5	6
(B) Limits for General Population/Uncontrolled Exposure				
0.3-1.34	614	1.63	*100	30
1.34-30	824/f	2.19/f	*180/f ²	30
30-300	27.5	0.073	0.2	30
300-1,500			f/1500	30
1,500-100,000			1.0	30

f = frequency in MHz

* = Plane-wave equivalent power density

EUT Setup

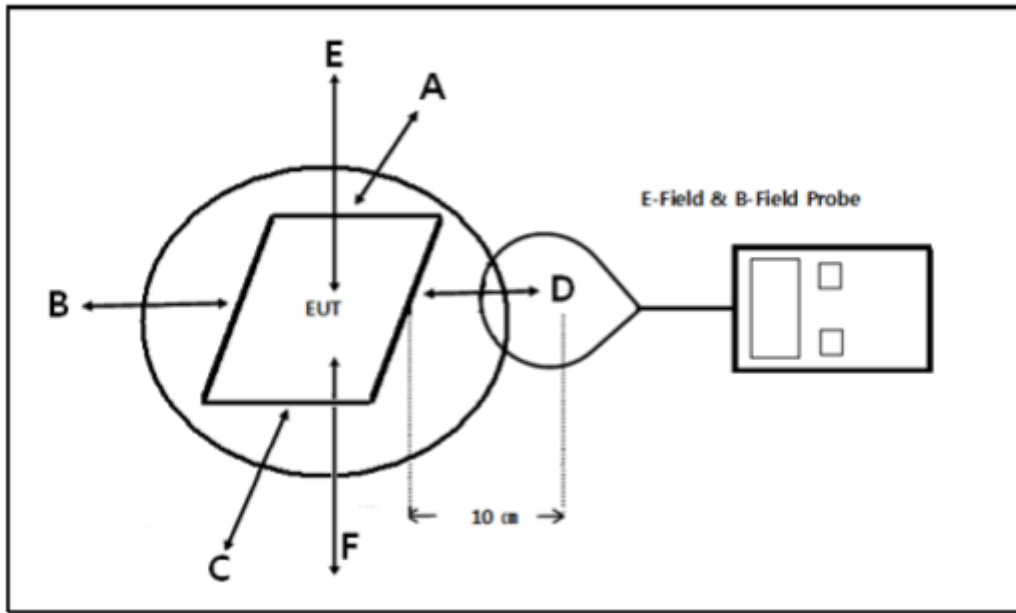

Test Equipment List and Details

Description	Manufacturer	Model	Serial Number	Calibration Date	Calibration Due Date
Exposure Level Tester	Narda	ELT-400	N-0215	2018/02/22	2019/02/21
Isotropic Probe	ETS-Lindgren	HI-6005	00201839	2018/02/22	2019/02/21

**Statement of Traceability:* BACL Corp. attests that all of the calibrations on the equipment items listed above were traceable to the SI System of Units via the R.O.C. Center for Measurement Standards of the Electronics Testing Center, Taiwan (ETC) or to another internationally recognized National Metrology Institute (NMI), and were compliant with the current Taiwan Accreditation Foundation (TAF) requirements.

Result

- a) Power transfer frequency is less than 1 MHz.
The transfer frequency is below 110 - 205kHz.
- b) Output power from each primary coil is less than or equal to 15 watts.
The device has three coils. Only one coil can be operated at a time and the transmit power is less than 5 watts.
- c) The transfer system includes only single primary and secondary coils. This includes charging systems that may have multiple primary coils and clients that are able to detect and allow coupling only between individual pairs of coils.
The transfer system including a charging system with only single primary coils is to detect and allow only between individual of coils.
- d) Client device is inserted in or placed directly in contact with the transmitter.
Client device is placed directly in contact with the transmitter.
- e) The maximum coupling surface area of the transmit (charging) device is between 60 c m² and 400 c m².
The EUT Coupling surface area (Type: Cycle)
 $\pi * R^2 = 3.14 * 5.1^2 = 81.67 \text{ c m}^2 > 60 \text{ cm}^2$
- f) Aggregate leakage fields at 10 cm surrounding the device from all simultaneous transmitting coils are demonstrated to be less than 30% of the MPE limit.
The EUT E-field Strength at 10cm & The EUT H-field Strength levels at 10cm are less than 30% the MPE limit.

Please refer the results below.

FCC

E-Filed Strength (10 cm)

Frequency Range (kHz)	Position A (V/m)	Position B (V/m)	Position C (V/m)	Position D (V/m)	Position E (V/m)	Position F (V/m)	30% Limit Test (V/m)	Limit Test (V/m)
110-205	8.56	7.91	10.55	8.33	13.69	7.62	184.2	614

H-Filed Strength (10 cm)

Frequency Range (kHz)	Position A (A/m)	Position B (A/m)	Position C (A/m)	Position D (A/m)	Position E (A/m)	Position F (A/m)	30% Limit Test (A/m)	Limit Test (A/m)
110-205	0.124	0.088	0.138	0.090	0.374	0.061	0.489	1.63

Note:

According with KDB 680106 D01 RF Exposure Wireless Charging Apps v02, Emissions between 100 kHz to 300 kHz should be assessed versus the limits at 300 kHz in Table 1 of Section 1.1310: 614V/m and 1.63 A/m.

FCC §15.207 – AC Line Conducted Emissions

Applicable Standard

According to FCC §15.207 Conducted limits:

For an intentional radiator that is designed to be connected to the public utility (AC) power line, the radio frequency voltage that is conducted back onto the AC power line on any frequency or frequencies within the band 150 kHz to 30 MHz shall not exceed the limits in the following table, as measured using a 50 μH/50 ohms line impedance stabilization network (LISN). Compliance with the provisions of this paragraph shall be based on the measurement of the radio frequency voltage between each power line and ground at the power terminal. The lower limit applies at the boundary between the frequencies ranges.

Frequency of Emission (MHz)	Conducted Limit (dBuV)	
	Quasi-Peak	Average
0.15-0.5	66 to 56 ^{Note 1}	56 to 46 ^{Note 2}
0.5-5	56	46
5-30	60	50

Note 1: Decreases with the logarithm of the frequency.

Note 2: A linear average detector is required

Measurement Uncertainty

Input quantities to be considered for conducted disturbance measurements maybe receiver reading, attenuation of the connection between LISN/ISN and receiver, LISN/ISN voltage division factor, LISN/ISN VDF frequency interpolation and receiver related input quantities, etc.

Based on CISPR 16-4-2:2011, the expended combined standard uncertainty of conducted disturbance test at Bay Area Compliance Laboratories Corp. (Taiwan) is shown as below. And the uncertainty will not be taken into consideration for the test data recorded in the report.

Port	Expanded Measurement uncertainty
AC Mains	4.64 dB (k=2, 95% level of confidence)

EUT Setup

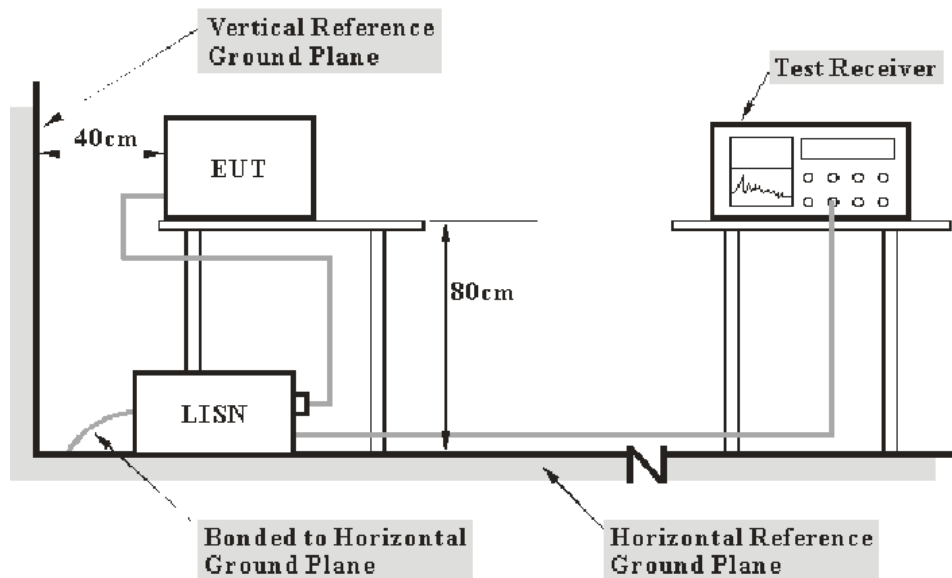

- Note:**
1. Support units were connected to second LISN.
 2. Both of LISNs (AMN) 80 cm from EUT and at the least 80 cm from other units and other metal planes support units.

The setup of EUT is according with per ANSI C63.10-2013 measurement procedure. The specification used was with the FCC Part 15.207 limits.

The external I/O cables were draped along the test table and formed a bundle 30 to 40 cm long in the middle.

The spacing between the peripherals was 10 cm.

EMI Test Receiver Setup

The EMI test receiver was set to investigate the spectrum from 150 kHz to 30 MHz.

During the conducted emission test, the EMI test receiver was set with the following configurations

Frequency Range	IF B/W
150 kHz – 30 MHz	9 kHz

Test Procedure

During the conducted emission test, the adapter was connected to the outlet of the LISN.

Maximizing procedure was performed on the six (6) highest emissions of the EUT.

All data was recorded in the Quasi-peak and average detection mode.

According FCC publication number 174176, for a device with a permanent antenna operating at or below 30 MHz, the measurements done with a suitable dummy load, in lieu of the permanent antenna under the following conditions: (1) perform the AC line conducted tests with the permanent antenna to determine compliance with the Section 15.207 limits outside the transmitter's fundamental emission band; (2) retest with a dummy load in lieu of the permanent antenna to determine compliance with the Section 15.207 limits within the transmitter's fundamental emission band.

Test Equipment List and Details

Description	Manufacturer	Model	Serial Number	Calibration Date	Calibration Due Date
LISN	Rohde & Schwarz	ENV216	101248	2017/07/20	2018/07/19
EMI Test Receiver	Rohde & Schwarz	ESR7	101419	2017/11/06	2018/11/05
Pulse Limiter	Rohde & Schwarz	ESH3Z2	TXZEM025	2017/08/11	2018/08/10
RF Cable	EMEC	EM-CB5D	001	2017/07/10	2018/07/09
Software	AUDIX	E3	V9.150826k	N.C.R	N.C.R

**Statement of Traceability: BACL Corp. attests that all of the calibrations on the equipment items listed above were traceable to the SI System of Units via the R.O.C. Center for Measurement Standards of the Electronics Testing Center, Taiwan (ETC) or to another internationally recognized National Metrology Institute (NMI), and were compliant with the current Taiwan Accreditation Foundation (TAF) requirements.*

Factor & Over Limit Calculation

The factor is calculated by adding LISN/ISN VDF (Voltage Division Factor), Cable Loss and Transient Limiter Attenuation. The basic equation is as follows:

$$\text{Factor} = \text{LISN VDF} + \text{Cable Loss} + \text{Transient Limiter Attenuation}$$

The “Over Limit” column of the following data tables indicates the degree of compliance with the applicable limit. For example, an over limit of -7 dB means the emission is 7 dB below the limit. The equation for Over Limit calculation is as follows:

$$\text{Over Limit} = \text{Level} - \text{Limit Line}$$

Test Results Summary

According to the recorded data in following table, the EUT complied with the FCC Part 15.207.

Environmental Conditions

Temperature:	25 °C
Relative Humidity:	58 %
ATM Pressure:	1008 hPa

The testing was performed by Kevin Kao on 2018-04-02.

Test Results: PASS

Please refer to the following plots and tables.

Mode: *Transmitting*

AC 120V/60 Hz, Line



倍科檢驗科技有限公司 Bay Area Compliance Labs Corp.

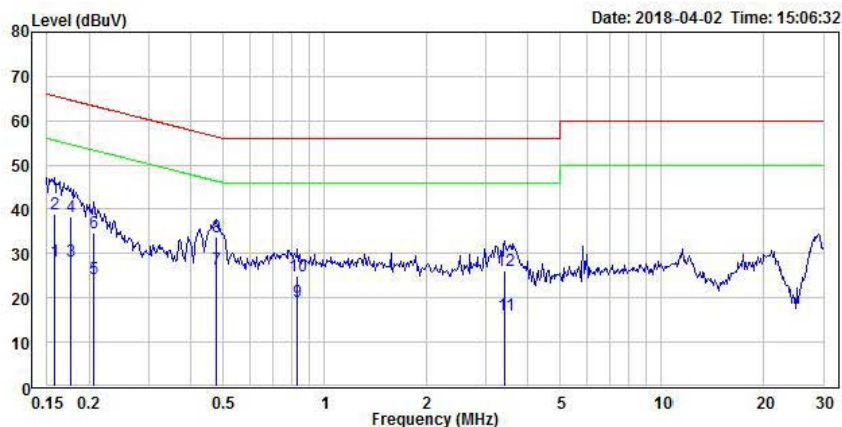

Condition: Line
 EUT :
 Model :
 Note :
 Power :

	Freq	Level	Limit	Over	Read		
	MHz	dBuV	Line	Limit	Factor	Level	Remark
			dBuV	dB	dB	dBuV	Pol/Phase
1	0.157	28.35	55.60	-27.25	19.50	8.85	Average Line
2	0.157	38.83	65.60	-26.77	19.50	19.33	QP Line
3	0.176	28.34	54.68	-26.34	19.50	8.84	Average Line
4	0.176	38.44	64.68	-26.24	19.50	18.94	QP Line
5	0.206	24.21	53.35	-29.14	19.50	4.71	Average Line
6	0.206	34.60	63.35	-28.75	19.50	15.10	QP Line
7	0.476	26.34	46.40	-20.06	19.51	6.83	Average Line
8	0.476	33.75	56.40	-22.65	19.51	14.24	QP Line
9	0.832	19.08	46.00	-26.92	19.52	-0.44	Average Line
10	0.832	24.87	56.00	-31.13	19.52	5.35	QP Line
11	3.435	16.07	46.00	-29.93	19.64	-3.57	Average Line
12	3.435	26.10	56.00	-29.90	19.64	6.46	QP Line

AC 120V/60 Hz, Neutral



倍科檢驗科技有限公司 Bay Area Compliance Labs Corp.

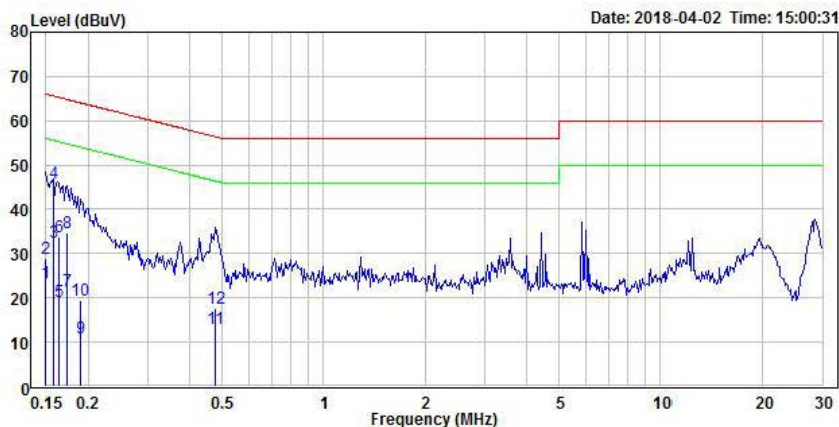

Condition: Neutral

EUT :
 Model :
 Note :
 Power :

	Freq	Level	Limit	Over	Read		
	MHz	dBuV	Line	Limit	Factor	Level	Remark
			dBuV	dB	dB	dBuV	Pol/Phase
1	0.150	23.39	56.00	-32.61	19.63	3.76	Average Neutral
2	0.150	28.81	66.00	-37.19	19.63	9.18	QP Neutral
3	0.157	32.40	55.60	-23.20	19.63	12.77	Average Neutral
4	0.157	46.04	65.60	-19.56	19.63	26.41	QP Neutral
5	0.164	19.30	55.27	-35.97	19.63	-0.33	Average Neutral
6	0.164	33.71	65.27	-31.56	19.63	14.08	QP Neutral
7	0.173	21.58	54.81	-33.23	19.63	1.95	Average Neutral
8	0.173	34.61	64.81	-30.20	19.63	14.98	QP Neutral
9	0.189	11.05	54.08	-43.03	19.63	-8.58	Average Neutral
10	0.189	19.56	64.08	-44.52	19.63	-0.07	QP Neutral
11	0.476	13.14	46.40	-33.26	19.64	-6.50	Average Neutral
12	0.476	17.62	56.40	-38.78	19.64	-2.02	QP Neutral

FCC §15.205 & §15.209 –Radiated Emissions

Applicable Standard

As per FCC §15.35(d): Unless otherwise specified, on any frequency or frequencies above 1000 MHz, the radiated emission limits are based on the use of measurement instrumentation employing an average detector function. Unless otherwise specified, measurements above 1000 MHz shall be performed using a minimum resolution bandwidth of 1 MHz.

As Per FCC §15.205(a) except as show in paragraph (d) of this section, only spurious emissions are permitted in any of the frequency bands listed below:

MHz	MHz	MHz	GHz
0.090 – 0.110	16.42 – 16.423		
0.495 – 0.505	16.69475 –	960 – 1240	4. 5 – 5. 15
2.1735 – 2.1905	16.69525	1300 – 1427	5. 35 – 5. 46
4.125 – 4.128	25.5 – 25.67	1435 – 1626.5	7.25 – 7.75
4.17725 – 4.17775	37.5 – 38.25	1645.5 – 1646.5	8.025 – 8.5
4.20725 – 4.20775	73 – 74.6	1660 – 1710	9.0 – 9.2
6.215 – 6.218	74.8 – 75.2	1718.8 – 1722.2	9.3 – 9.5
6.26775 – 6.26825	108 – 121.94	2200 – 2300	10.6 – 12.7
6.31175 – 6.31225	123 – 138	2310 – 2390	13.25 – 13.4
8.291 – 8.294	149.9 – 150.05	2483.5 – 2500	14.47 – 14.5
8.362 – 8.366	156.52475 –	2690 – 2900	15.35 – 16.2
8.37625 – 8.38675	156.52525	3260 – 3267	17.7 – 21.4
8.41425 – 8.41475	156.7 – 156.9	3.332 – 3.339	22.01 – 23.12
12.29 – 12.293	162.0125 –167.17	3 3458 – 3 358	23.6 – 24.0
12.51975 –	167.72 – 173.2	3.600 – 4.400	31.2 – 31.8
12.52025	240 – 285		36.43 – 36.5
12.57675 –	322 – 335.4		Above 38.6
12.57725	399.9 – 410		
13.36 – 13.41	608 – 614		

As per FCC §15.209(a): Except as provided elsewhere in this Subpart, the emissions from an intentional radiator shall not exceed the field strength levels specified in the following table:

Frequency (MHz)	Field Strength (micro volts/meter)	Measurement Distance (meters)
0.009 - 0.490	2400/F(kHz)	300
0.490 - 1.705	24000/F(kHz)	30
1.705 - 30.0	30	30
30 - 88	100**	3
88 - 216	150**	3
216 - 960	200**	3
Above 960	500	3

** Except as provided in paragraph (g), fundamental emissions from intentional radiators operating under this Section shall not be located in the frequency bands 54-72 MHz, 76-88 MHz, 174-216 MHz or 470-806 MHz. However, operation within these frequency bands is permitted under other sections of this Part, e.g., Sections 15.231 and 15.241.

Measurement Uncertainty

All measurements involve certain levels of uncertainties, especially in field of EMC. The factors contributing to uncertainties are spectrum analyzer, cable loss, antenna factor calibration, antenna directivity, antenna factor variation with height, antenna phase center variation, antenna factor frequency interpolation, measurement distance variation, site imperfections, mismatch (average), and system repeatability.

Based on CISPR 16-4-2:2011, the expended combined standard uncertainty of radiation emissions at Bay Area Compliance Laboratories Corp. (Taiwan) is shown in below table. And the uncertainty will not be taken into consideration for the test data recorded in the report

Frequency	Measurement uncertainty
9 kHz~30MHz	3.20 dB (k=2, 95% level of confidence)
30MHz~200MHz	3.76 dB (k=2, 95% level of confidence)
200MHz~1GHz	4.12 dB (k=2, 95% level of confidence)

EUT Setup

9 kHz- 30 MHz:

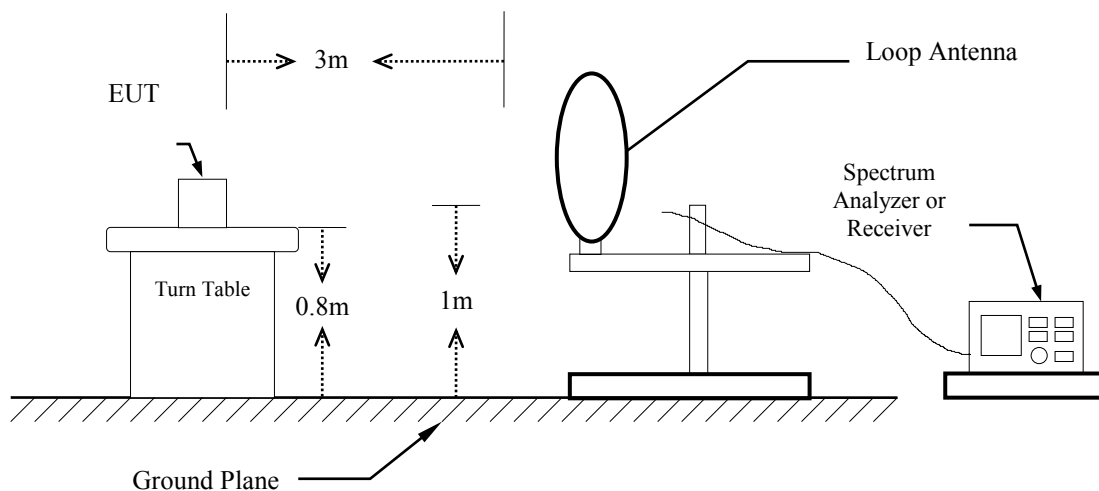

30 MHz – 1 GHz:

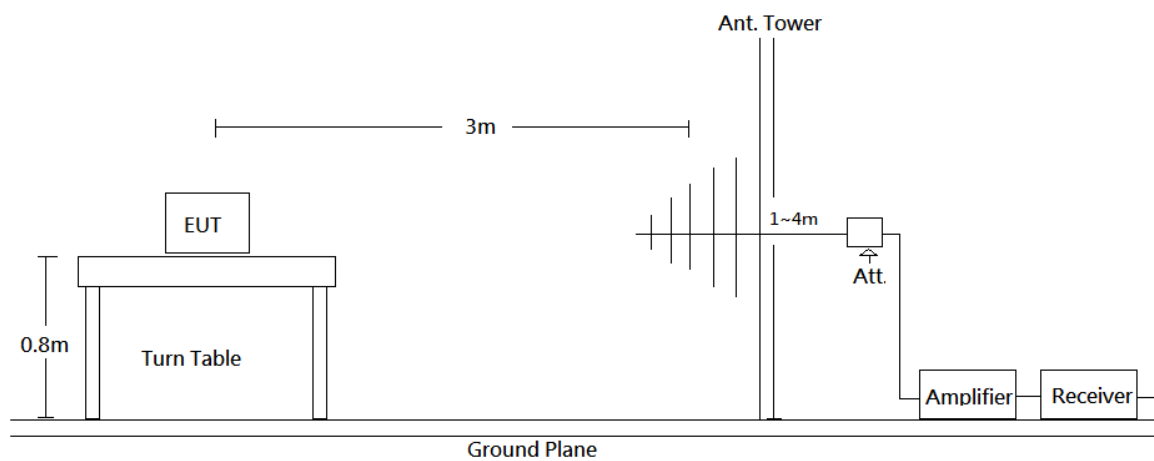

The radiated emission tests were performed in the 3 meters chamber test site, using the setup accordance with the ANSI C63.10-2013. The specification used was the FCC 15.209 and FCC 15.205 limits.

The spacing between the peripherals was 10 cm.

The adapter was connected to 120VAC/60Hz power source.

EMI Test Receiver Setup

The system was investigated from 9 kHz to 1 GHz.

During the radiated emission test, the EMI test receiver was set with the following configurations

Frequency Range	RBW	RBW Video B/W	Detector
9 kHz –150 kHz	200 Hz	1kHz	QP
150 kHz – 30 MHz	9 kHz	30 kHz	QP
30MHz – 1000 MHz	120 kHz	300 kHz	QP

Note: The frequency bands 9-90 kHz and 110-490 kHz, the testing is based on average detector.

Test Procedure

Maximizing procedure was performed on the highest emissions to ensure that the EUT complied with all installation combinations.

The EUT is set 3 meter away from the testing antenna, which is varied from 1-4 meter, and the EUT is placed on a turntable, which is 0.8 meter above ground plane, the table shall be rotated for 360 degrees to find out the highest emission. The receiving antenna should be changed the polarization both of horizontal and vertical.

Test Equipment List and Details**Radiation (966-A)**

Description	Manufacturer	Model	Serial Number	Calibration Date	Calibration Due Date
Active Loop Antenna	ETS-Lindgren	6502	00035796	2018/03/02	2019/03/01
Bilog Antenna	Sunol & Mini-Circuits	JB6/UNAT-6+	A050115/15542_01	2017/12/20	2018/12/19
Horn Antenna	EMCO	3115	9311-4158	2017/05/31	2018/05/30
Horn Antenna	ETS-Lindgren	3116	62638	2017/09/04	2018/09/03
Preamplifier	Sonoma	310N	130602	2017/07/03	2018/07/02
Preamplifier	EMEC	EM01G18G	60697	2017/04/14	2018/04/13
Preamplifier	EMEC	EM18G40G	060656	2018/01/15	2019/01/14
EMI Test Receiver	Rohde & Schwarz	ESR7	101419	2017/11/06	2018/11/05
Spectrum Analyzer	Rohde & Schwarz	FSV40	101203	2017/07/13	2018/07/12
Microflex Cable	UTIFLEX	UFB311A-Q-1440-300300	220490-006	2017/10/31	2018/10/30
Microflex Cable	UTIFLEX	UFA210A-1-3149-300300	MFR64639 226389-001	2017/11/10	2018/11/09
Microflex Cable	ROSNO	K1K50-UP0264-K1K50-450CM	160309-1	2018/03/05	2019/03/04
Microflex Cable	ROSNO	K1K50-UP0264-K1K50-80CM	160309-2	2018/01/17	2019/01/16
Turn Table	Champro	TT-2000	060772-T	N.C.R	N.C.R
Antenna Tower	Champro	AM-BS-4500-B	060772-A	N.C.R	N.C.R
Controller	Champro	EM1000	60772	N.C.R	N.C.R
Software	Farad	EZ_EM	BACL-03A1	N.C.R	N.C.R
NSA	BACL	966-A	N/A	2017/07/24	2018/07/23
VSWR	BACL	966-A	N/A	2017/07/25	2018/07/24

**Statement of Traceability: BACL Corp. attests that all of the calibrations on the equipment items listed above were traceable to the SI System of Units via the R.O.C. Center for Measurement Standards of the Electronics Testing Center, Taiwan (ETC) or to another internationally recognized National Metrology Institute (NMI), and were compliant with the current Taiwan Accreditation Foundation (TAF) requirements.*

Correct Factor & Margin Calculation

The Correct Factor is calculated by adding the Antenna Factor and Cable Loss, and subtracting the Amplifier Gain from the Meter Reading. The basic equation is as follows:

$$\text{Correct Factor} = \text{Antenna Factor} + \text{Cable Loss} - \text{Amplifier Gain} + \text{Attenuator}$$

The “Margin” column of the following data tables indicates the degree of compliance with the applicable limit. For example, a margin of 7 dB means the emission is 7 dB below the limit. The equation for margin calculation is as follows:

$$\text{Margin} = \text{Limit} - \text{Result}$$

Test Results Summary

According to the data in the following table, the EUT complied with the FCC §15.209.

Environmental Conditions

Temperature:	25 °C
Relative Humidity:	60 %
ATM Pressure:	1010 hPa

The testing was performed by Tom Hsu on 2018-03-29.

Test Results: PASS

Mode: Transmitting (9kHz - 30MHz)

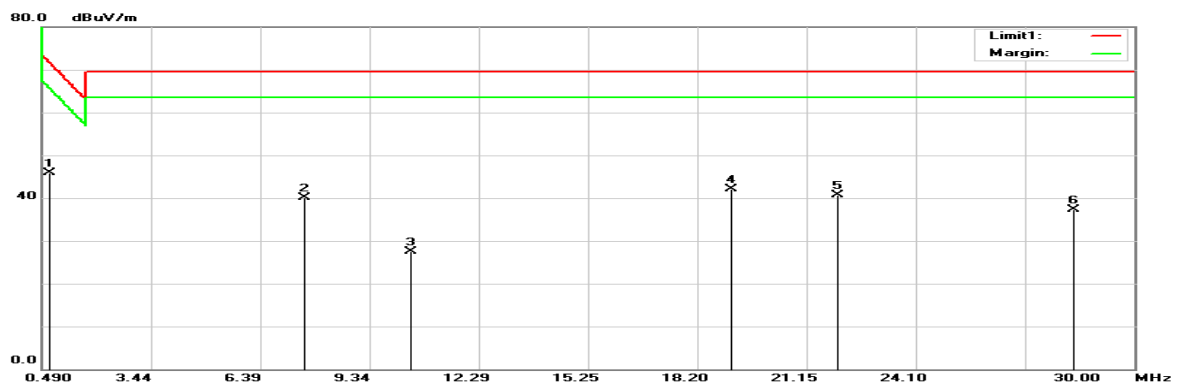
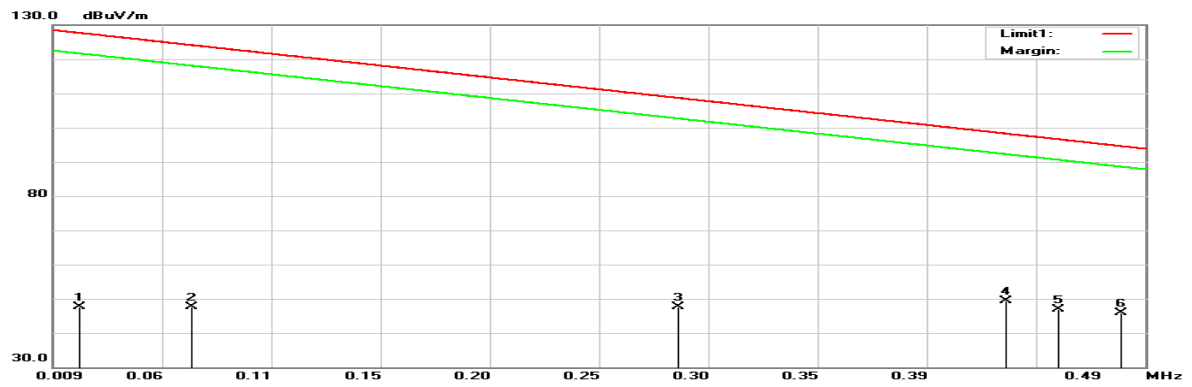

Frequency	Reading	Correct	Result	Limit	Margin	Height	Degree	Remark
(MHz)	(dBμV)	Factor(dB/m)	(dBμV/m)	(dBμV/m)	(dB)	(cm)	(°)	
0.0210	30.55	17.06	47.61	127.63	-80.02	100	246	AVG
0.0701	34.44	13.15	47.59	124.09	-76.50	100	335	AVG
*0.1432	47.80	12.66	60.46	118.82	-58.36	100	102	AVG
0.2846	35.09	12.54	47.63	108.62	-60.99	100	24	AVG
0.4290	37.20	12.30	49.50	98.20	-48.70	100	293	AVG
0.4515	34.54	12.27	46.81	96.58	-49.77	100	360	AVG
0.4794	33.69	12.22	45.91	94.56	-48.65	100	320	AVG
0.6966	33.48	12.33	45.81	71.96	-26.15	100	314	QP
7.6020	27.98	12.11	40.09	69.50	-29.41	100	66	QP
10.4644	15.44	12.02	27.46	69.50	-42.04	100	340	QP
19.1403	30.05	12.04	42.09	69.50	-27.41	100	202	QP
22.0028	29.15	11.62	40.77	69.50	-28.73	100	18	QP
28.3770	27.07	10.25	37.32	69.50	-32.18	100	53	QP

Note:

Result = Reading + Correct Factor

Margin = Result –Limit

Correct Factor = Antenna Factor + Cable Loss – Amplifier Gain + Attenuator

“*” Means Fundamental frequency

Limit calculation: Limit at specified distance + 40log (300/3) = Limit + 80 dB for up to 0.49 MHz

Limit at specified distance + 40log (30/3) = Limit + 40 dB for above 0.49 MHz up to 1.075 MHz

According to §15.209 (d), the measurements were tested by using Quasi peak detector except for the frequency bands 9 – 90 kHz, 110 – 490 kHz and above 1 GHz in these three bands on measurements employing an average detector.

Emissions more than 20dB below the limit are not recorded.

30 MHz- 1 GHz / Horizontal

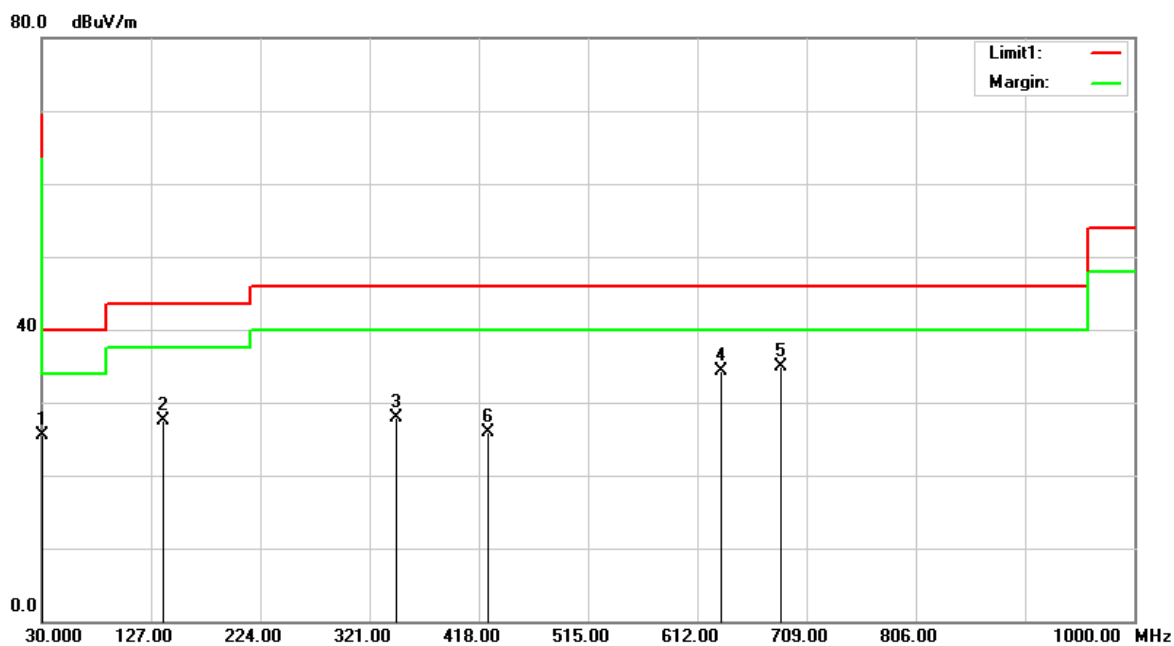

Frequency (MHz)	Reading (dBμV)	Correct Factor(dB/m)	Result (dBμV/m)	Limit (dBμV/m)	Margin (dB)	Height (cm)	Degree (°)	Remark
30.0000	28.75	-3.26	25.49	40.00	-14.51	100	338	QP
137.6700	38.39	-10.83	27.56	43.50	-15.94	100	59	QP
344.2800	36.65	-8.76	27.89	46.00	-18.11	100	265	QP
633.3400	38.03	-3.70	34.33	46.00	-11.67	100	47	QP
685.7200	37.88	-2.94	34.94	46.00	-11.06	100	35	QP
425.7600	33.05	-7.05	26.00	46.00	-20.00	100	62	QP

Note:

Result = Reading + Correct Factor

Margin = Result –Limit

Correct Factor = Antenna Factor + Cable Loss – Amplifier Gain + Attenuator

Emissions more than 20dB below the limit are not recorded.

Vertical

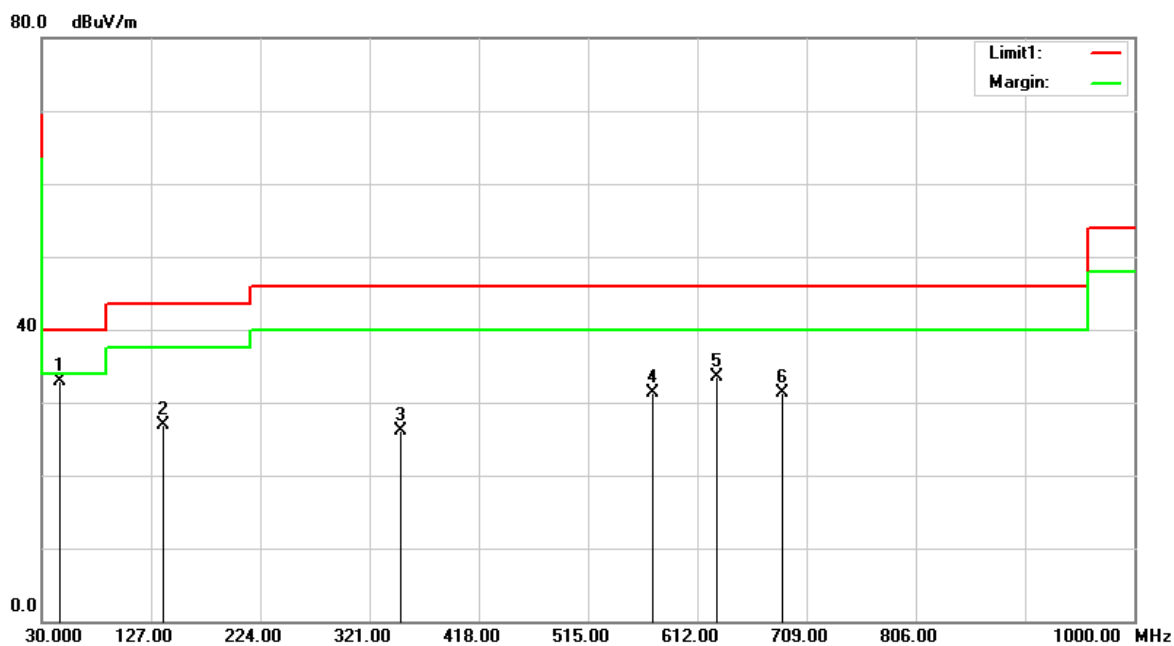

Frequency (MHz)	Reading (dBμV)	Correct Factor(dB/m)	Result (dBμV/m)	Limit (dBμV/m)	Margin (dB)	Height (cm)	Degree (°)	Remark
45.5200	47.18	-14.24	32.94	40.00	-7.06	100	212	QP
137.6700	37.64	-10.83	26.81	43.50	-16.69	100	30	QP
348.1600	34.86	-8.67	26.19	46.00	-19.81	100	357	QP
572.2300	36.04	-4.64	31.40	46.00	-14.60	100	345	QP
629.4600	37.35	-3.76	33.59	46.00	-12.41	100	359	QP
687.6600	34.31	-2.92	31.39	46.00	-14.61	100	49	QP

Note:

Result = Reading + Correct Factor

Margin = Result –Limit

Correct Factor = Antenna Factor + Cable Loss – Amplifier Gain + Attenuator

Emissions more than 20dB below the limit are not recorded.

FCC§15.215(c) –Emission Bandwidth

Applicable Standard

According to FCC 15.215

Intentional radiators operating under the alternative provisions to the general emission limits, as contained in §§ 15.217 through 15.257 and in Subpart E of this part, must be designed to ensure that the 20 dB bandwidth of the emission, or whatever bandwidth may otherwise be specified in the specific rule section under which the equipment operates, is contained within the frequency band designated in the rule section under which the equipment is operated.

Test Procedure

According to ANSI C63.10-2013

20 dB Emission Bandwidth

- a) The spectrum analyzer center frequency is set to the nominal EUT channel center frequency. The span range for the EMI receiver or spectrum analyzer shall be between two times and five times the OBW.
- b) The nominal IF filter bandwidth (3 dB RBW) shall be in the range of 1% to 5% of the OBW and video bandwidth (VBW) shall be approximately three times RBW, unless otherwise specified by the applicable requirement.
- c) Set the reference level of the instrument as required, keeping the signal from exceeding the maximum input mixer level for linear operation. In general, the peak of the spectral envelope shall be more than $[10 \log (\text{OBW}/\text{RBW})]$ below the reference level. Specific guidance is given in 4.1.5.2.
- d) Steps a) through c) might require iteration to adjust within the specified tolerances.
- e) The dynamic range of the instrument at the selected RBW shall be more than 10 dB below the target “-xx dB down” requirement; that is, if the requirement calls for measuring the -20 dB OBW, the instrument noise floor at the selected RBW shall be at least 30 dB below the reference value.
- f) Set detection mode to peak and trace mode to max hold.
- g) Determine the reference value: Set the EUT to transmit an unmodulated carrier or modulated signal, as applicable. Allow the trace to stabilize. Set the spectrum analyzer marker to the highest level of the displayed trace (this is the reference value).
- h) Determine the “-xx dB down amplitude” using $[(\text{reference value}) - \text{xx}]$. Alternatively, this calculation may be made by using the marker-delta function of the instrument.
- i) If the reference value is determined by an unmodulated carrier, then turn the EUT modulation ON, and either clear the existing trace or start a new trace on the spectrum analyzer and allow the new trace to stabilize. Otherwise, the trace from step g) shall be used for step j).
- j) Place two markers, one at the lowest frequency and the other at the highest frequency of the envelope of the spectral display, such that each marker is at or slightly below the “-xx dB down amplitude” determined in step h). If a marker is below this “-xx dB down amplitude” value, then it

shall be as close as possible to this value. The occupied bandwidth is the frequency difference between the two markers. Alternatively, set a marker at the lowest frequency of the envelope of the spectral display, such that the marker is at or slightly below the “-xx dB down amplitude” determined in step h). Reset the marker-delta function and move the marker to the other side of the emission until the delta marker amplitude is at the same level as the reference marker amplitude. The marker-delta frequency reading at this point is the specified emission bandwidth.

k) The occupied bandwidth shall be reported by providing plot(s) of the measuring instrument display; the plot axes and the scale units per division shall be clearly labeled. Tabular data may be reported in addition to the plot(s).

Test Equipment List and Details

Description	Manufacturer	Model	Serial Number	Calibration Date	Calibration Due Date
Spectrum Analyzer	Rohde & Schwarz	FSV40	101140	2017/11/15	2018/11/14
Cable	WOKEN	SFL402	S02-160323-07	2018/02/12	2019/02/11

**Statement of Traceability: BACL Corp. attests that all of the calibrations on the equipment items listed above were traceable to the SI System of Units via the R.O.C. Center for Measurement Standards of the Electronics Testing Center, Taiwan (ETC) or to another internationally recognized National Metrology Institute (NMI), and were compliant with the current Taiwan Accreditation Foundation (TAF) requirements.*

Test Environmental Conditions

Temperature:	25 °C
Relative Humidity:	55 %
ATM Pressure:	1010 hPa

The testing was performed by Andy Shih on 2018-03-09.

Test Results

Test Mode: Transmitting

Frequency (kHz)	20 dB Emission Bandwidth (kHz)
110-205	173.7

20 dB Emission Bandwidth

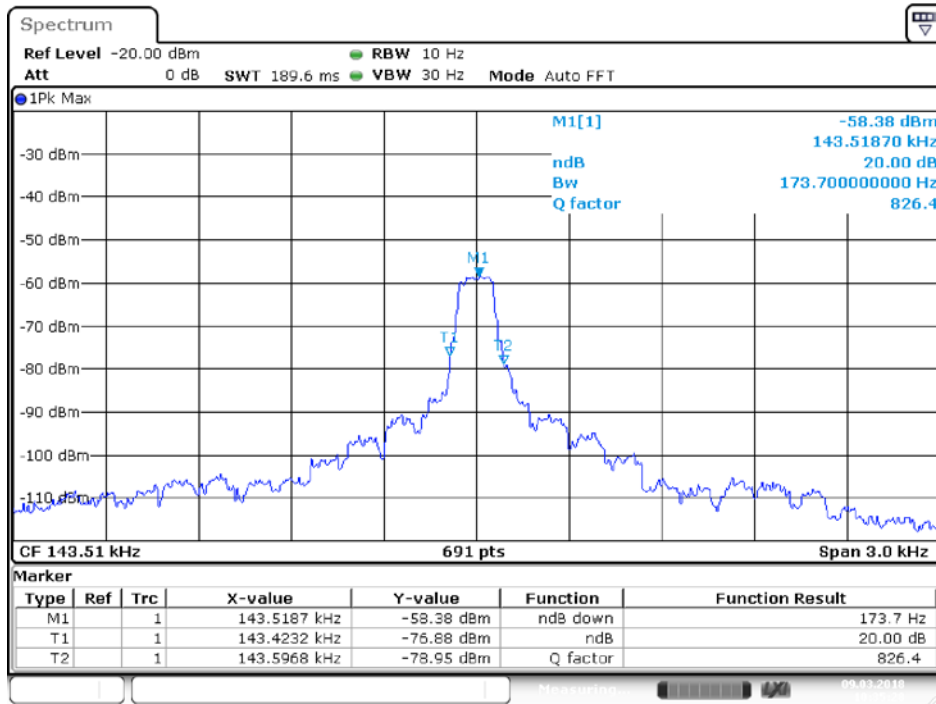

Date: 9.MAR.2016 10:35:28

***** END OF REPORT *****