



FCC TEST REPORT (WLAN 15.407)

REPORT NO.: RF131223D01-1

MODEL NO.: HA815

FCC ID: 2ACNOHA815

RECEIVED: Dec. 30, 2013

TESTED: Feb. 26 ~ Apr. 1, 2014

ISSUED: Apr. 23, 2014

APPLICANT: I/O INTERCONNECT INC.

ADDRESS: 5F, No.19-3, Sanchong Rd., Nangang District, Taipei
115, Taiwan, R.O.C.

ISSUED BY: Bureau Veritas Consumer Products Services (H.K.) Ltd.,
Taoyuan Branch

LAB ADDRESS: No. 47, 14th Ling, Chia Pau Vil., Lin Kou Dist., New
Taipei City, Taiwan (R.O.C.)

This report should not be used by the client to claim product certification, approval, or endorsement by TAF or any government agencies.



This report is for your exclusive use. Any copying or replication of this report to or for any other person or entity, or use of our name or trademark, is permitted only with our prior written permission. This report sets forth our findings solely with respect to the test samples identified herein. The results set forth in this report are not indicative or representative of the quality or characteristics of the lot from which a test sample was taken or any similar or identical product unless specifically and expressly noted. Our report includes all of the tests requested by you and the results thereof based upon the information that you provided to us. You have 60 days from date of issuance of this report to notify us of any material error or omission caused by our negligence, provided, however, that such notice shall be in writing and shall specifically address the issue you wish to raise. A failure to raise such issue within the prescribed time shall constitute your unqualified acceptance of the completeness of this report, the tests conducted and the correctness of the report contents. Unless specific mention, the uncertainty of measurement has been explicitly taken into account to declare the compliance or non-compliance to the specification.



TABLE OF CONTENTS

RELEASE CONTROL RECORD	4
1. CERTIFICATION.....	5
2. SUMMARY OF TEST RESULTS	6
2.1 MEASUREMENT UNCERTAINTY	6
3. GENERAL INFORMATION	7
3.1 GENERAL DESCRIPTION OF EUT	7
3.2 DESCRIPTION OF TEST MODES	9
3.2.1 TEST MODE APPLICABILITY AND TESTED CHANNEL DETAIL.....	10
3.3 DUTY CYCLE OF TEST SIGNAL	12
3.4 DESCRIPTION OF SUPPORT UNITS	15
3.4.1 CONFIGURATION OF SYSTEM UNDER TEST.....	15
3.5 GENERAL DESCRIPTION OF APPLIED STANDARDS.....	16
4. TEST TYPES AND RESULTS	17
4.1 RADIATED EMISSION AND BANDEDGE MEASUREMENT	17
4.1.1 LIMITS OF RADIATED EMISSION AND BANDEDGE MEASUREMENT ..	17
4.1.2 LIMITS OF UNWANTED EMISSION OUT OF THE RESTRICTED BANDS	17
4.1.3 TEST INSTRUMENTS.....	18
4.1.4 TEST PROCEDURES	19
4.1.5 DEVIATION FROM TEST STANDARD	19
4.1.6 TEST SETUP.....	20
4.1.7 EUT OPERATING CONDITION.....	20
4.1.8 TEST RESULTS	21
4.2 CONDUCTED EMISSION MEASUREMENT.....	39
4.2.1 LIMITS OF CONDUCTED EMISSION MEASUREMENT	39
4.2.2 TEST INSTRUMENTS.....	39
4.2.3 TEST PROCEDURES	40
4.2.4 DEVIATION FROM TEST STANDARD	40
4.2.5 TEST SETUP.....	40
4.2.6 EUT OPERATING CONDITIONS	40
4.2.7 TEST RESULTS	41
4.3 PEAK TRANSMIT POWER MEASUREMENT.....	43
4.3.1 LIMITS OF PEAK TRANSMIT POWER MEASUREMENT	43
4.3.2 TEST SETUP.....	43
4.3.3 TEST INSTRUMENTS.....	44
4.3.4 TEST PROCEDURE.....	44
4.3.5 DEVIATION FROM TEST STANDARD	44
4.3.6 EUT OPERATING CONDITIONS	44
4.3.7 TEST RESULTS	45
4.4 PEAK POWER SPECTRAL DENSITY MEASUREMENT.....	47
4.4.1 LIMITS OF PEAK POWER SPECTRAL DENSITY MEASUREMENT	47
4.4.2 TEST SETUP.....	47
4.4.3 TEST INSTRUMENTS.....	47
4.4.4 TEST PROCEDURES	47
4.4.5 DEVIATION FROM TEST STANDARD	47
4.4.6 EUT OPERATING CONDITIONS	47
4.4.7 TEST RESULTS	48



4.5	PEAK POWER EXCURSION MEASUREMENT.....	50
4.5.1	LIMITS OF PEAK POWER EXCURSION MEASUREMENT	50
4.5.2	TEST SETUP.....	50
4.5.3	TEST INSTRUMENTS.....	50
4.5.4	TEST PROCEDURE.....	50
4.5.5	DEVIATION FROM TEST STANDARD.....	50
4.5.6	EUT OPERATING CONDITIONS	50
4.5.7	TEST RESULTS	51
4.6	FREQUENCY STABILITY.....	52
4.6.1	LIMITS OF FREQUENCY STABILITY MEASUREMENT.....	52
4.6.2	TEST SETUP.....	52
4.6.3	TEST INSTRUMENTS.....	52
4.6.4	TEST PROCEDURE.....	53
4.6.5	DEVIATION FROM TEST STANDARD.....	53
4.6.6	EUT OPERATING CONDITION.....	53
4.6.7	TEST RESULTS	54
5.	PHOTOGRAPHS OF THE TEST CONFIGURATION	55
6.	INFORMATION ON THE TESTING LABORATORIES.....	56
7.	APPENDIX A – MODIFICATIONS RECORDERS FOR ENGINEERING CHANGES TO THE EUT BY THE LAB.....	57



A D T

RELEASE CONTROL RECORD

ISSUE NO.	REASON FOR CHANGE	DATE ISSUED
RF131223D01-1	Original release	Apr. 23, 2014



1. CERTIFICATION

PRODUCT: HP Wireless Display Adapter
BRAND NAME: HP
MODEL: HA815
APPLICANT: I/O INTERCONNECT INC.
TESTED: Feb. 26 ~ Apr. 1, 2014
TEST SAMPLE: ENGINEERING SAMPLE
STANDARDS: FCC Part 15, Subpart E (Section 15.407)
ANSI C63.10-2009

The above equipment (Model: TL10IE2) has been tested by **Bureau Veritas Consumer Products Services (H.K.) Ltd., Taoyuan Branch**, and found compliance with the requirement of the above standards. The test record, data evaluation & Equipment Under Test (EUT) configurations represented herein are true and accurate accounts of the measurements of the sample's EMC characteristics under the conditions specified in this report.

PREPARED BY : Celia Chen , **DATE:** Apr. 23, 2014
(Celia Chen / Senior Specialist)

APPROVED BY : Rex Lai , **DATE:** Apr. 23, 2014
(Rex Lai / Assistant Manager)

2. SUMMARY OF TEST RESULTS

The EUT has been tested according to the following specifications:

APPLIED STANDARD: FCC PART 15, SUBPART E (SECTION 15.407)			
STANDARD SECTION	TEST TYPE	RESULT	REMARK
15.407(b)(6)	AC Power Conducted Emission	PASS	Meet the requirement of limit. Minimum passing margin is -4.97dB at 0.48068MHz.
15.407(b/1/2/3)(b)(6)	Radiated Emissions	PASS	Meet the requirement of limit. Minimum passing margin is -1.0dB at 5150.00MHz.
15.407(a/1/2)	Max Average Transmit Power	PASS	Meet the requirement of limit.
15.407(a)(6)	Peak Power Excursion	PASS	Meet the requirement of limit.
15.407(a/1/2)	Peak Power Spectral Density	PASS	Meet the requirement of limit.
15.407(g)	Frequency Stability	PASS	Meet the requirement of limit.
15.203	Antenna Requirement	PASS	Antenna connector is I-PEX not a standard connector.

2.1 MEASUREMENT UNCERTAINTY

Where relevant, the following measurement uncertainty levels have been estimated for tests performed on the EUT as specified in CISPR 16-4-2:

MEASUREMENT	FREQUENCY	UNCERTAINTY
Conducted emissions	150kHz~30MHz	3.43 dB
Radiated emissions	30MHz ~ 1GHz	4.00 dB
	Above 1GHz	3.36 dB

This uncertainty represents an expanded uncertainty expressed at approximately the 95% confidence level using a coverage factor of $k = 2$.

3. GENERAL INFORMATION

3.1 GENERAL DESCRIPTION OF EUT

EUT	HP Wireless Display Adapter
MODEL NO.	HA815
POWER SUPPLY	5Vdc from AC adapter
MODULATION TYPE	64QAM, 16QAM, QPSK, BPSK
MODULATION TECHNOLOGY	OFDM
TRANSFER RATE	802.11a: 54.0/ 48.0/ 36.0/ 24.0/ 18.0/ 12.0/ 9.0/ 6.0Mbps 802.11n: up to 150Mbps
OPERATING FREQUENCY	5180 ~ 5240MHz
NUMBER OF CHANNEL	4 for 802.11a, 802.11n (20MHz) 2 for 802.11n (40MHz)
OUTPUT POWER	18.8mW
ANTENNA TYPE	Refer to note below
ANTENNA CONNECTOR	Refer to note below
DATA CABLE	HDMI to D-Sub adapter
I/O PORTS	Refer to user's manual
ACCESSORY DEVICES	Refer to Note as below

NOTE:

1. The EUT is a HP Wireless Display Adapter.
2. The frequency bands used in this EUT are listed as below.

Frequency Band (MHz)	2412~2462	5180~5240	5745~5825
802.11b	√	-	-
802.11g	√	-	-
802.11a	-	√	√
802.11n (20MHz)	√	√	√
802.11n (40MHz)	√	√	√

3. The EUT incorporates a SISO function. Physically, the EUT provides one completed transmitter and one receiver.

Modulation Mode	Tx Function
802.11b	1TX
802.11g	1TX
802.11a	1TX
802.11n (20MHz)	1TX
802.11n (40MHz)	1TX

4. The following antennas were applied to the EUT:

	Antenna	Type	Connector	Gain (dBi)		
				2.4GHz	5180~5240MHz	5745~5825MHz
Embedded	A	Dipole	I-PEX	0.53	0.16	-0.55
On-board	B	PIFA	-	1.5	1.38	-0.02

5. The EUT consumes power from the following adapter

Brand	Chicony				
Model	W12-010N3E	W12-010N3F	W12-010N3C	W12-010N3A	W12-010N3B
Plug Type	Plug Type G	Plug Type I	Plug Type A	Plug Type A	Plug type C
Input Power	100-240Vac, 50/60Hz, 0.3A				
Output Power	5Vdc, 2A				
Power Line	AC 2 Pin Non-shielded USB to Micro USB (1.8m) with one ferrite core.				
※ Above adapters are identical with each other except for their plug type difference					

6. The above EUT information is declared by manufacturer and for more detailed features description, please refer to the manufacturer's specifications or user's manual.



3.2 DESCRIPTION OF TEST MODES

FOR 5180 ~ 5240MHz

4 channels are provided for 802.11a, 802.11n (20MHz):

CHANNEL	FREQUENCY	CHANNEL	FREQUENCY
36	5180 MHz	44	5220 MHz
40	5200 MHz	48	5240 MHz

2 channels are provided for 802.11n (40MHz):

CHANNEL	FREQUENCY	CHANNEL	FREQUENCY
38	5190 MHz	46	5230 MHz

3.2.1 TEST MODE APPLICABILITY AND TESTED CHANNEL DETAIL

EUT CONFIGURE MODE	APPLICABLE TO				DESCRIPTION
	RE \geq 1G	RE<1G	PLC	APCM	
-	√	√	√	√	-

Where **RE \geq 1G**: Radiated Emission above 1GHz
RE<1G: Radiated Emission below 1GHz
PLC: Power Line Conducted Emission
APCM: Antenna Port Conducted Measurement

RADIATED EMISSION TEST (ABOVE 1GHz):

- Pre-Scan has been conducted to determine the worst-case mode from all possible combinations between available modulations, data rates and antenna ports (if EUT with antenna diversity architecture).
- Following channel(s) was (were) selected for the final test as listed below.

MODE	FREQ. BAND (MHz)	AVAILABLE CHANNEL	TESTED CHANNEL	MODULATION TECHNOLOGY	MODULATION TYPE	DATA RATE (Mbps)	ANTENNA
802.11a	5180-5240	36 to 48	36, 40, 48	OFDM	BPSK	6.0	A & B
802.11n (20MHz)		36 to 48	36, 40, 48	OFDM	BPSK	6.5	
802.11n (40MHz)		38 to 46	38, 46	OFDM	BPSK	13	

RADIATED EMISSION TEST (BELOW 1GHz):

- Pre-Scan has been conducted to determine the worst-case mode from all possible combinations between available modulations, data rates and antenna ports (if EUT with antenna diversity architecture).
- Following channel(s) was (were) selected for the final test as listed below.

MODE	FREQ. BAND (MHz)	AVAILABLE CHANNEL	TESTED CHANNEL	MODULATION TECHNOLOGY	MODULATION TYPE	DATA RATE (Mbps)	ANTENNA
802.11a	5180-5240	36 to 48	36	OFDM	BPSK	6.0	A & B

POWER LINE CONDUCTED EMISSION TEST:

- Pre-Scan has been conducted to determine the worst-case mode from all possible combinations between available modulations, data rates and antenna ports (if EUT with antenna diversity architecture).
- Following channel(s) was (were) selected for the final test as listed below.

MODE	FREQ. BAND (MHz)	AVAILABLE CHANNEL	TESTED CHANNEL	MODULATION TECHNOLOGY	MODULATION TYPE	DATA RATE (Mbps)
802.11a	5180-5240	36 to 48	36	OFDM	BPSK	6.0

ANTENNA PORT CONDUCTED MEASUREMENT:

- This item includes all test value of each mode, but only includes spectrum plot of worst value of each mode.
- Pre-Scan has been conducted to determine the worst-case mode from all possible combinations between available modulations, data rates and antenna ports (if EUT with antenna diversity architecture).
- Following channel(s) was (were) selected for the final test as listed below.

MODE	FREQ. BAND (MHz)	AVAILABLE CHANNEL	TESTED CHANNEL	MODULATION TECHNOLOGY	MODULATION TYPE	DATA RATE (Mbps)
802.11a	5180-5240	36 to 48	36, 40, 48	OFDM	BPSK	6.0
802.11n (20MHz)		36 to 48	36, 40, 48	OFDM	BPSK	6.5
802.11n (40MHz)		38 to 46	38, 46	OFDM	BPSK	13

TEST CONDITION:

APPLICABLE TO	ENVIRONMENTAL CONDITIONS	INPUT POWER	TESTED BY
RE≥1G	23deg. C, 73% RH	120Vac, 60Hz	Joey Liu
RE<1G	23deg. C, 73% RH	120Vac, 60Hz	Joey Liu
PLC	21deg. C, 81% RH	120Vac, 60Hz	Jary Huang
APCM	25deg. C, 60%RH	120Vac, 60Hz	Saxon Lee

3.3 DUTY CYCLE OF TEST SIGNAL

Duty cycle is < 98%, duty factor shall be considered.

802.11a:

BPSK: Duty cycle = $2.040 / 2.180 = 0.936$, Duty factor = $10 * \log(1 / 0.936) = 0.29$

QPSK: Duty cycle = $1.307 / 1.401 = 0.933$, Duty factor = $10 * \log(1 / 0.933) = 0.30$

16QAM: Duty cycle = $0.392 / 0.420 = 0.933$, Duty factor = $10 * \log(1 / 0.933) = 0.30$

64QAM: Duty cycle = $0.238 / 0.272 = 0.875$, Duty factor = $10 * \log(1 / 0.875) = 0.58$

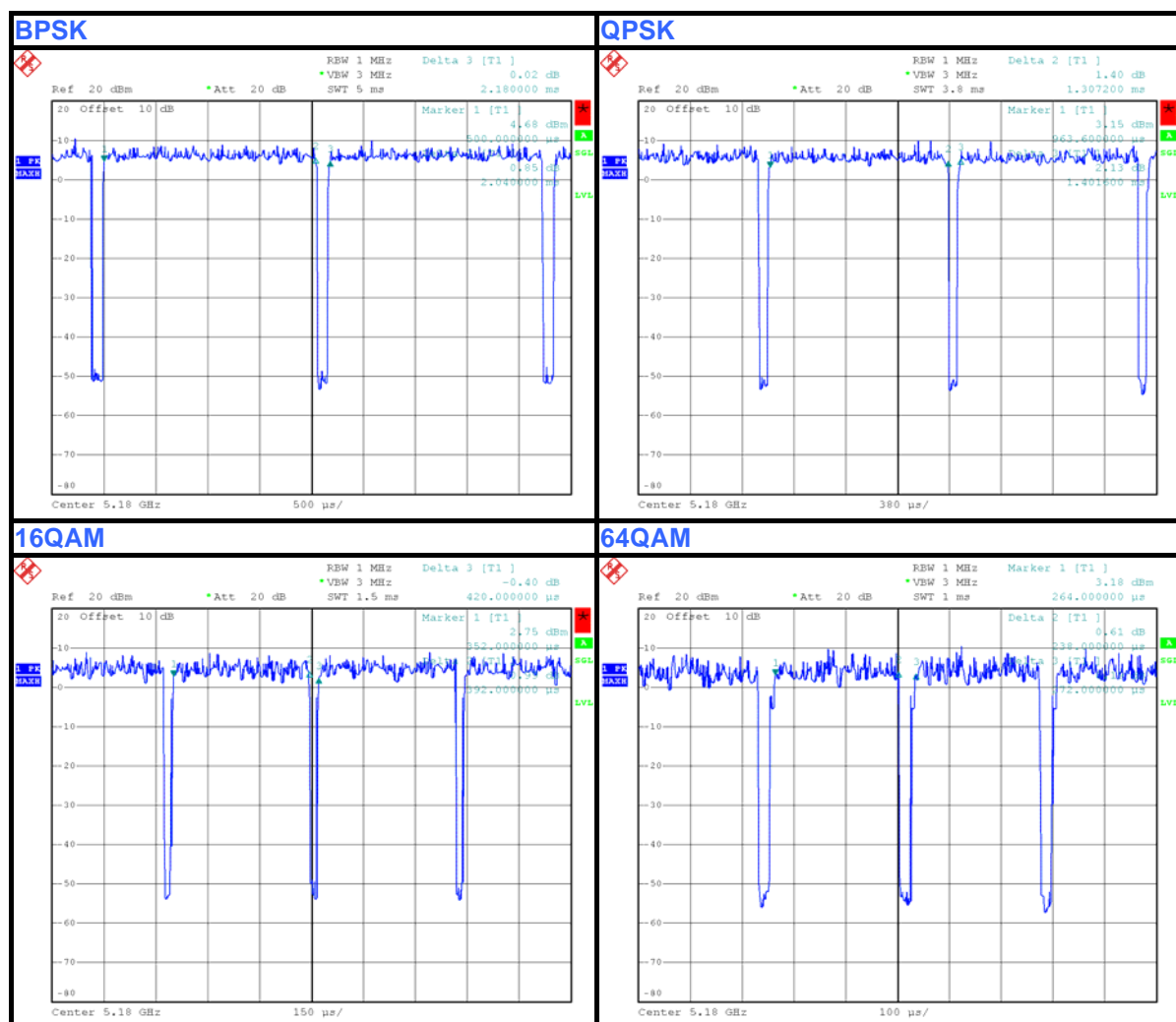

802.11n (20MHz)

BPSK: Duty cycle = $1.888 / 2.002 = 0.943$, Duty factor = $10 * \log(1 / 0.943) = 0.25$

QPSK: Duty cycle = $0.664 / 0.709 = 0.937$, Duty factor = $10 * \log(1 / 0.937) = 0.28$

16QAM: Duty cycle = $0.332 / 0.364 = 0.912$, Duty factor = $10 * \log(1 / 0.912) = 0.40$

64QAM: Duty cycle = $0.208 / 0.238 = 0.874$, Duty factor = $10 * \log(1 / 0.874) = 0.59$

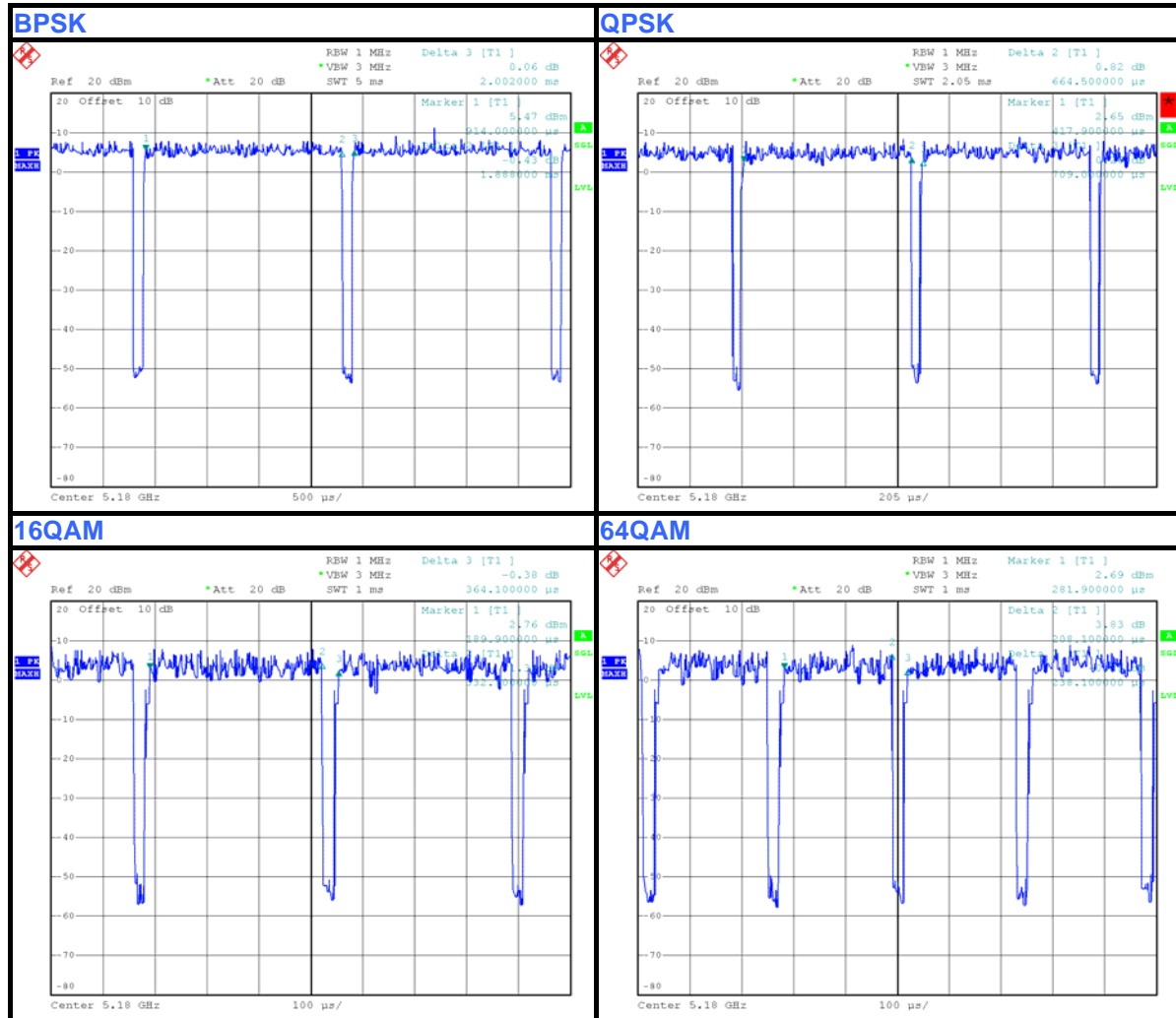



802.11n (40MHz):

BPSK: Duty cycle = $0.922 / 1.030 = 0.895$, Duty factor = $10 * \log(1 / 0.895) = 0.48$

QPSK: Duty cycle = $0.318 / 0.362 = 0.878$, Duty factor = $10 * \log(1 / 0.878) = 0.56$

16QAM: Duty cycle = $0.156 / 0.199 = 0.784$, Duty factor = $10 * \log(1 / 0.784) = 1.06$

64QAM: Duty cycle = $0.106 / 0.139 = 0.763$, Duty factor = $10 * \log(1 / 0.763) = 1.18$

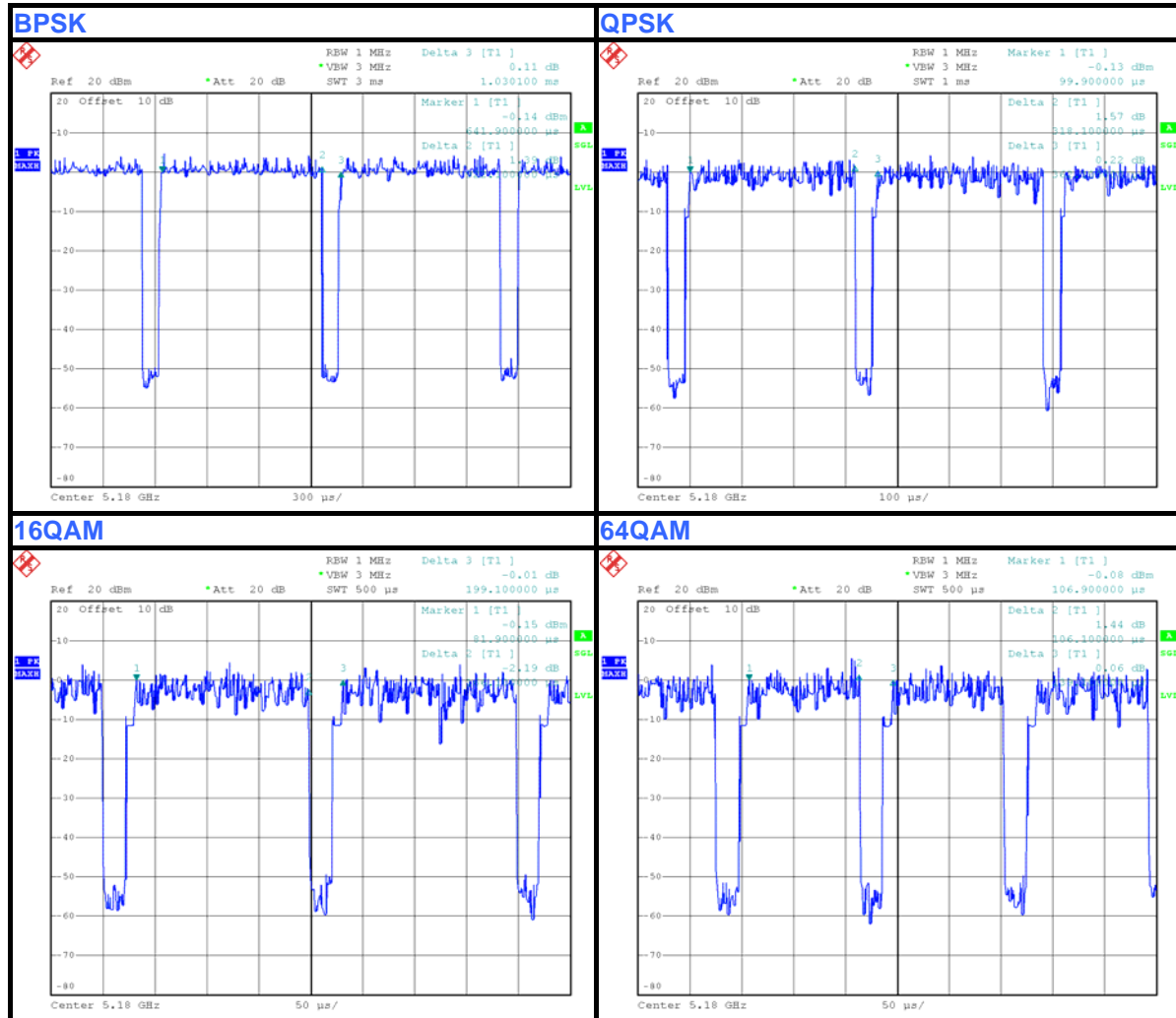

3.4 DESCRIPTION OF SUPPORT UNITS

The EUT has been tested as an independent unit together with other necessary accessories or support units. The following support units or accessories were used to form a representative test configuration during the tests.

Except for Radiated Emission test

NO.	PRODUCT	BRAND	MODEL NO.	SERIAL NO.	FCC ID
1	24" LCD MONITOR	DELL	U2410	CN082WXD728 720CC0LGL	FCC DoC Approved

For Radiated Emission test

NO.	PRODUCT	BRAND	MODEL NO.	SERIAL NO.	FCC ID
1	Notebook	DELL	E5410	BW33YM1	FCC DoC Approved

3.4.1 CONFIGURATION OF SYSTEM UNDER TEST

Except for Radiated Emission test

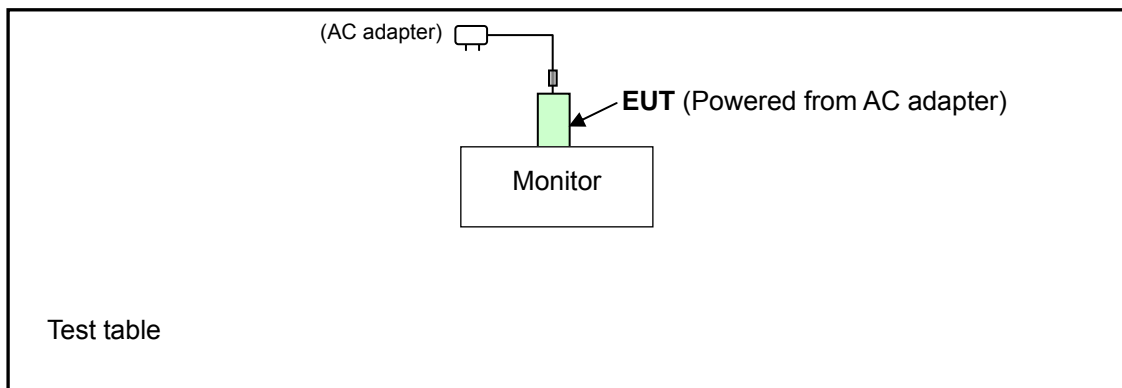

For Radiated Emission test

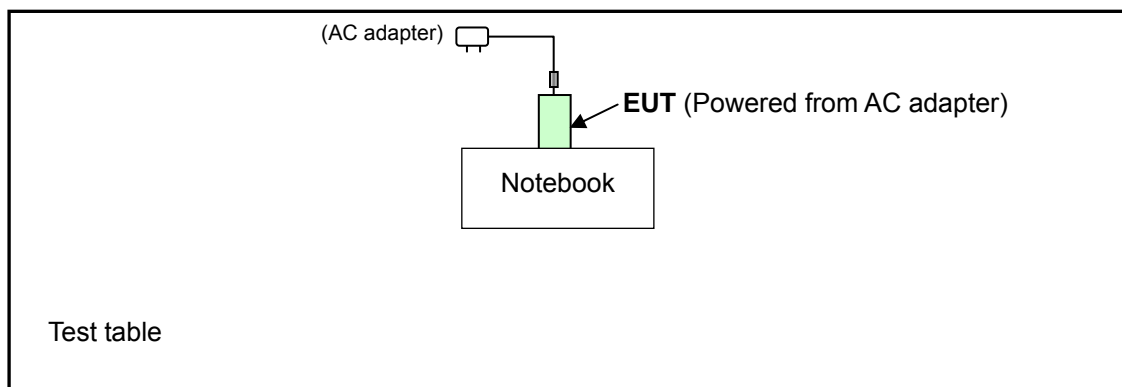



3.5 GENERAL DESCRIPTION OF APPLIED STANDARDS

The EUT is a RF Product. According to the specifications of the manufacturer, it must comply with the requirements of the following standards:

FCC Part 15, Subpart E (15.407)

789033 D01 General UNII Test Procedures Old Rules v01r04

ANSI C63.10-2009

All test items have been performed and recorded as per the above standards.

4. TEST TYPES AND RESULTS

4.1 RADIATED EMISSION AND BANDEDGE MEASUREMENT

4.1.1 LIMITS OF RADIATED EMISSION AND BANDEDGE MEASUREMENT

Radiated emissions which fall in the restricted bands must comply with the radiated emission limits specified as below table:

FREQUENCIES (MHz)	FIELD STRENGTH (microvolts/meter)	MEASUREMENT DISTANCE (meters)
0.009 ~ 0.490	2400/F(kHz)	300
0.490 ~ 1.705	24000/F(kHz)	30
1.705 ~ 30.0	30	30
30 ~ 88	100	3
88 ~ 216	150	3
216 ~ 960	200	3
Above 960	500	3

NOTE:

1. The lower limit shall apply at the transition frequencies.
2. Emission level (dBuV/m) = 20 log Emission level (uV/m).
3. For frequencies above 1000MHz, the field strength limits are based on average detector, however, the peak field strength of any emission shall not exceed the maximum permitted average limits, specified above by more than 20dB under any condition of modulation.

4.1.2 LIMITS OF UNWANTED EMISSION OUT OF THE RESTRICTED BANDS

APPLICABLE TO	LIMIT	
√	FIELD STRENGTH AT 3m (dBμV/m)	
	PK	AV
	74	54
	EIRP LIMIT (dBm)	EQUIVALENT FIELD STRENGTH AT 3m (dBμV/m)
	PK	PK
	-27	68.3

NOTE: The following formula is used to convert the equipment isotropic radiated power (eirp) to field strength:

$$E = \frac{1000000\sqrt{30P}}{3} \mu\text{V/m, where P is the eirp (Watts).}$$



4.1.3 TEST INSTRUMENTS

DESCRIPTION & MANUFACTURER	MODEL NO.	SERIAL NO.	CALIBRATED DATE	CALIBRATED UNTIL
HP Preamplifier	8447D	2432A03504	Feb. 26, 2014	Feb. 25, 2015
HP Preamplifier	8449B	3008A01201	Feb. 26, 2014	Feb. 25, 2015
Agilent TEST RECEIVER	N9038A	MY51210129	Jan. 18, 2014	Jan. 17, 2015
Schwarzbeck Antenna	VULB 9168	139	Feb. 24, 2014	Feb. 23, 2015
Schwarzbeck Antenna	VHBA 9123	480	May 29, 2013	May 28, 2015
ADT. Turn Table	TT100	0306	NA	NA
ADT. Tower	AT100	0306	NA	NA
Software	ADT_Radiated_V 7.6.15.9.4	NA	NA	NA
SUHNER RF cable	SF102	CABLE-CH6	Aug. 16, 2013	Aug. 15, 2014
Schwarzbeck Horn Antenna	BBHA 9120-D1	D130	May 13, 2013	May 12, 2014
Highpass filter Wainwright Instruments	WHK 3.1/18G-10SS	SN 8	NA	NA
ROHDE & SCHWARZ Spectrum Analyzer	FSP 40	100036	May. 17, 2013	May. 16, 2014
Anritsu Power Sensor	MA2411B	0738404	Apr. 24, 2013	Apr. 23, 2014
Anritsu Power Meter	ML2495A	0842014	Apr. 25, 2013	Apr. 24, 2014

- NOTE:**
1. The calibration interval of the above test instruments is 12/24 months. And the calibrations are traceable to NML/ROC and NIST/USA.
 2. The horn antenna and HP preamplifier (model: 8449B) are used only for the measurement of emission frequency above 1GHz if tested.
 3. The test was performed in Chamber No. 6.
 4. The Industry Canada Reference No. IC 7450E-6.
 5. The FCC Site Registration No. is 447212.

4.1.4 TEST PROCEDURES

- a. The EUT was placed on the top of a rotating table 0.8 meters above the ground at a 3 meter semi-anechoic chamber. The table was rotated 360 degrees to determine the position of the highest radiation.
- b. The EUT was set 3 meters away from the interference-receiving antenna, which was mounted on the top of a variable-height antenna tower.
- c. The antenna is a broadband antenna, and its height is varied from one meter to four meters above the ground to determine the maximum value of the field strength. Both horizontal and vertical polarizations of the antenna are set to make the measurement.
- d. For each suspected emission, the EUT was arranged to its worst case and then the antenna was tuned to heights from 1 meter to 4 meters and the rotatable table was turned from 0 degrees to 360 degrees to find the maximum reading.
- e. The test-receiver system was set to Peak Detect Function and Specified Bandwidth with Maximum Hold Mode.
- f. If the emission level of the EUT in peak mode was 10dB lower than the limit specified, then testing could be stopped and the peak values of the EUT would be reported. Otherwise the emissions that did not have 10dB margin would be re-tested one by one using peak, quasi-peak or average method as specified and then reported in a data sheet.

NOTE:

1. The resolution bandwidth and video bandwidth of test receiver/spectrum analyzer is 120kHz for Quasi-peak detection at frequency below 1GHz.
2. The resolution bandwidth of test receiver/spectrum analyzer is 1MHz and video bandwidth is 3MHz for Peak detection at frequency above 1GHz.
3. The resolution bandwidth of test receiver/spectrum analyzer is 1MHz and the video bandwidth is $\geq 1/T$ (Duty cycle < 98%) or 10Hz(Duty cycle > 98%) for Average detection (AV) at frequency above 1GHz.
4. All modes of operation were investigated and the worst-case emissions are reported.

4.1.5 DEVIATION FROM TEST STANDARD

No deviation.

4.1.6 TEST SETUP

Frequency range 30MHz~1GHz

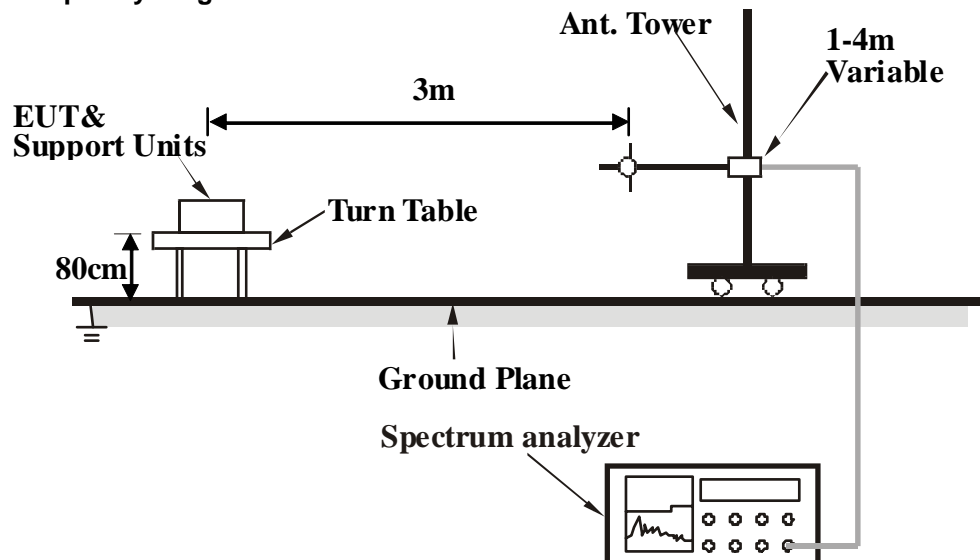

Frequency range above 1GHz

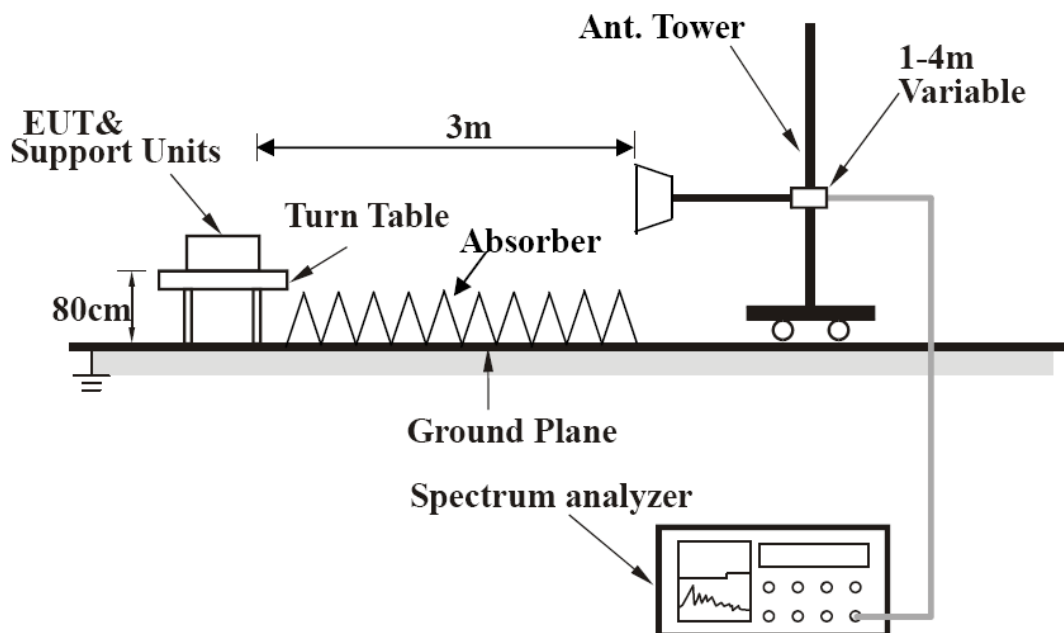

For the actual test configuration, please refer to the attached file (Test Setup Photo).

4.1.7 EUT OPERATING CONDITION

- Connected the EUT to Notebook.
- Set the EUT under transmitting condition.

4.1.8 TEST RESULTS

ABOVE 1GHz DATA

802.11a

CHANNEL	TX Channel 36	DETECTOR FUNCTION	Peak (PK)
FREQUENCY RANGE	1GHz ~ 40GHz		Average (AV)
ANTENNA	A		

ANTENNA POLARITY & TEST DISTANCE: HORIZONTAL AT 3 M								
NO.	FREQ. (MHz)	EMISSION LEVEL (dBuV/m)	LIMIT (dBuV/m)	MARGIN (dB)	ANTENNA HEIGHT (m)	TABLE ANGLE (Degree)	RAW VALUE (dBuV)	CORRECTION FACTOR (dB/m)
1	5150.00	68.5 PK	74.0	-5.5	1.00 H	27	65.83	2.71
2	5150.00	48.6 AV	54.0	-5.4	1.00 H	27	45.87	2.71
3	*5180.00	104.4 PK			1.00 H	27	101.63	2.73
4	*5180.00	93.1 AV			1.00 H	27	90.37	2.73
5	#10360.00	58.6 PK	74.0	-15.4	1.00 H	35	44.34	14.28
6	#10360.00	45.9 AV	54.0	-8.1	1.00 H	35	31.65	14.28
ANTENNA POLARITY & TEST DISTANCE: VERTICAL AT 3 M								
NO.	FREQ. (MHz)	EMISSION LEVEL (dBuV/m)	LIMIT (dBuV/m)	MARGIN (dB)	ANTENNA HEIGHT (m)	TABLE ANGLE (Degree)	RAW VALUE (dBuV)	CORRECTION FACTOR (dB/m)
1	5150.00	73.0 PK	74.0	-1.0	1.00 V	328	70.29	2.71
2	5150.00	52.3 AV	54.0	-1.7	1.00 V	328	49.63	2.71
3	*5180.00	108.9 PK			1.00 V	328	106.17	2.73
4	*5180.00	98.0 AV			1.00 V	328	95.26	2.73
5	#10360.00	65.2 PK	74.0	-8.8	1.00 V	335	50.93	14.28
6	#10360.00	50.4 AV	54.0	-3.6	1.00 V	335	36.08	14.28

REMARKS:

1. Emission Level(dBuV/m) = Raw Value(dBuV) + Correction Factor(dB/m)
2. Correction Factor(dB/m) = Antenna Factor(dB/m) + Cable Factor(dB) – Pre-Amplifier Factor(dB)
3. The other emission levels were very low against the limit.
4. Margin value = Emission Level – Limit value
5. " * ": Fundamental frequency.
6. " # ": The radiated frequency is out of the restricted band.

CHANNEL	TX Channel 40	DETECTOR FUNCTION	Peak (PK)
FREQUENCY RANGE	1GHz ~ 40GHz		Average (AV)
ANTENNA	A		

ANTENNA POLARITY & TEST DISTANCE: HORIZONTAL AT 3 M								
NO.	FREQ. (MHz)	EMISSION LEVEL (dBuV/m)	LIMIT (dBuV/m)	MARGIN (dB)	ANTENNA HEIGHT (m)	TABLE ANGLE (Degree)	RAW VALUE (dBuV)	CORRECTION FACTOR (dB/m)
1	*5200.00	104.3 PK			1.00 H	12	101.53	2.73
2	*5200.00	92.9 AV			1.00 H	12	90.21	2.73
3	#10400.00	58.7 PK	74.0	-15.3	1.00 H	53	44.35	14.39
4	#10400.00	45.9 AV	54.0	-8.1	1.00 H	53	31.53	14.39

ANTENNA POLARITY & TEST DISTANCE: VERTICAL AT 3 M								
NO.	FREQ. (MHz)	EMISSION LEVEL (dBuV/m)	LIMIT (dBuV/m)	MARGIN (dB)	ANTENNA HEIGHT (m)	TABLE ANGLE (Degree)	RAW VALUE (dBuV)	CORRECTION FACTOR (dB/m)
1	*5200.00	108.8 PK			1.00 V	331	106.05	2.73
2	*5200.00	97.9 AV			1.00 V	331	95.13	2.73
3	#10400.00	64.5 PK	74.0	-9.5	1.00 V	335	50.13	14.39
4	#10400.00	49.9 AV	54.0	-4.1	1.00 V	335	35.55	14.39

REMARKS:

1. Emission Level(dBuV/m) = Raw Value(dBuV) + Correction Factor(dB/m)
2. Correction Factor(dB/m) = Antenna Factor(dB/m) + Cable Factor(dB) – Pre-Amplifier Factor(dB)
3. The other emission levels were very low against the limit.
4. Margin value = Emission Level – Limit value
5. " * ": Fundamental frequency.
6. " # ": The radiated frequency is out of the restricted band.

CHANNEL	TX Channel 48	DETECTOR FUNCTION	Peak (PK)
FREQUENCY RANGE	1GHz ~ 40GHz		Average (AV)
ANTENNA	A		

ANTENNA POLARITY & TEST DISTANCE: HORIZONTAL AT 3 M

NO.	FREQ. (MHz)	EMISSION LEVEL (dBuV/m)	LIMIT (dBuV/m)	MARGIN (dB)	ANTENNA HEIGHT (m)	TABLE ANGLE (Degree)	RAW VALUE (dBuV)	CORRECTION FACTOR (dB/m)
1	*5240.00	104.3 PK			1.00 H	20	101.46	2.81
2	*5240.00	92.8 AV			1.00 H	20	90.01	2.81
3	5350.00	55.3 PK	74.0	-18.7	1.00 H	20	52.16	3.15
4	5350.00	42.6 AV	54.0	-11.4	1.00 H	20	39.43	3.15
5	#10480.00	60.3 PK	74.0	-13.7	1.00 H	53	45.63	14.64
6	#10480.00	47.8 AV	54.0	-6.2	1.00 H	53	33.15	14.64

ANTENNA POLARITY & TEST DISTANCE: VERTICAL AT 3 M

NO.	FREQ. (MHz)	EMISSION LEVEL (dBuV/m)	LIMIT (dBuV/m)	MARGIN (dB)	ANTENNA HEIGHT (m)	TABLE ANGLE (Degree)	RAW VALUE (dBuV)	CORRECTION FACTOR (dB/m)
1	*5240.00	108.3 PK			1.00 V	339	105.52	2.81
2	*5240.00	98.6 AV			1.00 V	339	95.75	2.81
3	5350.00	55.5 PK	74.0	-18.5	1.00 V	339	52.39	3.15
4	5350.00	41.6 AV	54.0	-12.4	1.00 V	339	38.45	3.15
5	#10480.00	62.4 PK	74.0	-11.7	1.00 V	354	47.71	14.64
6	#10480.00	47.7 AV	54.0	-6.3	1.00 V	354	33.08	14.64

REMARKS:

1. Emission Level(dBuV/m) = Raw Value(dBuV) + Correction Factor(dB/m)
2. Correction Factor(dB/m) = Antenna Factor(dB/m) + Cable Factor(dB) – Pre-Amplifier Factor(dB)
3. The other emission levels were very low against the limit.
4. Margin value = Emission Level – Limit value
5. " * ": Fundamental frequency.
6. " # ": The radiated frequency is out of the restricted band.

CHANNEL	TX Channel 36	DETECTOR FUNCTION	Peak (PK)
FREQUENCY RANGE	1GHz ~ 40GHz		Average (AV)
ANTENNA	B		

ANTENNA POLARITY & TEST DISTANCE: HORIZONTAL AT 3 M								
NO.	FREQ. (MHz)	EMISSION LEVEL (dBuV/m)	LIMIT (dBuV/m)	MARGIN (dB)	ANTENNA HEIGHT (m)	TABLE ANGLE (Degree)	RAW VALUE (dBuV)	CORRECTION FACTOR (dB/m)
1	5150.00	57.8 PK	74.0	-16.2	1.46 H	158	55.06	2.71
2	5150.00	44.3 AV	54.0	-9.7	1.46 H	158	41.58	2.71
3	*5180.00	98.5 PK			1.46 H	158	95.78	2.73
4	*5180.00	85.9 AV			1.46 H	158	83.21	2.73
5	#10360.00	58.0 PK	74.0	-16.0	1.46 H	158	43.70	14.28
6	#10360.00	45.4 AV	54.0	-8.7	1.46 H	158	31.07	14.28

ANTENNA POLARITY & TEST DISTANCE: VERTICAL AT 3 M								
NO.	FREQ. (MHz)	EMISSION LEVEL (dBuV/m)	LIMIT (dBuV/m)	MARGIN (dB)	ANTENNA HEIGHT (m)	TABLE ANGLE (Degree)	RAW VALUE (dBuV)	CORRECTION FACTOR (dB/m)
1	5150.00	63.3 PK	74.0	-10.7	1.25 V	195	60.56	2.71
2	5150.00	46.2 AV	54.0	-7.8	1.25 V	195	43.46	2.71
3	*5180.00	103.7 PK			1.25 V	198	100.94	2.73
4	*5180.00	91.0 AV			1.25 V	198	88.25	2.73
5	#10360.00	59.4 PK	74.0	-14.6	1.25 V	200	45.15	14.28
6	#10360.00	45.5 AV	54.0	-8.5	1.25 V	200	31.25	14.28

REMARKS:

1. Emission Level(dBuV/m) = Raw Value(dBuV) + Correction Factor(dB/m)
2. Correction Factor(dB/m) = Antenna Factor(dB/m) + Cable Factor(dB) – Pre-Amplifier Factor(dB)
3. The other emission levels were very low against the limit.
4. Margin value = Emission Level – Limit value
5. " * ": Fundamental frequency.
6. " # ": The radiated frequency is out of the restricted band.

CHANNEL	TX Channel 40	DETECTOR FUNCTION	Peak (PK)
FREQUENCY RANGE	1GHz ~ 40GHz		Average (AV)
ANTENNA	B		

ANTENNA POLARITY & TEST DISTANCE: HORIZONTAL AT 3 M								
NO.	FREQ. (MHz)	EMISSION LEVEL (dBuV/m)	LIMIT (dBuV/m)	MARGIN (dB)	ANTENNA HEIGHT (m)	TABLE ANGLE (Degree)	RAW VALUE (dBuV)	CORRECTION FACTOR (dB/m)
1	*5200.00	97.8 PK			1.46 H	153	95.11	2.73
2	*5200.00	86.4 AV			1.46 H	153	83.66	2.73
3	#10400.00	58.2 PK	74.0	-15.8	1.46 H	153	43.77	14.39
4	#10400.00	45.6 AV	54.0	-8.4	1.46 H	153	31.23	14.39

ANTENNA POLARITY & TEST DISTANCE: VERTICAL AT 3 M								
NO.	FREQ. (MHz)	EMISSION LEVEL (dBuV/m)	LIMIT (dBuV/m)	MARGIN (dB)	ANTENNA HEIGHT (m)	TABLE ANGLE (Degree)	RAW VALUE (dBuV)	CORRECTION FACTOR (dB/m)
1	*5200.00	103.6 PK			1.11 V	198	100.83	2.73
2	*5200.00	90.9 AV			1.11 V	198	88.13	2.73
3	#10400.00	57.7 PK	74.0	-16.3	1.14 V	198	43.29	14.39
4	#10400.00	45.3 AV	54.0	-8.8	1.14 V	198	30.86	14.39

REMARKS:

1. Emission Level(dBuV/m) = Raw Value(dBuV) + Correction Factor(dB/m)
2. Correction Factor(dB/m) = Antenna Factor(dB/m) + Cable Factor(dB) – Pre-Amplifier Factor(dB)
3. The other emission levels were very low against the limit.
4. Margin value = Emission Level – Limit value
5. " * ": Fundamental frequency.
6. " # ": The radiated frequency is out of the restricted band.

CHANNEL	TX Channel 48	DETECTOR FUNCTION	Peak (PK)
FREQUENCY RANGE	1GHz ~ 40GHz		Average (AV)
ANTENNA	B		

ANTENNA POLARITY & TEST DISTANCE: HORIZONTAL AT 3 M

NO.	FREQ. (MHz)	EMISSION LEVEL (dBuV/m)	LIMIT (dBuV/m)	MARGIN (dB)	ANTENNA HEIGHT (m)	TABLE ANGLE (Degree)	RAW VALUE (dBuV)	CORRECTION FACTOR (dB/m)
1	*5240.00	98.4 PK			1.46 H	164	95.57	2.81
2	*5240.00	87.7 AV			1.46 H	164	84.90	2.81
3	5350.00	55.1 PK	74.0	-18.9	1.46 H	164	51.98	3.15
4	5350.00	40.8 AV	54.0	-13.2	1.46 H	164	37.69	3.15
5	#10480.00	57.2 PK	74.0	-16.8	1.46 H	164	42.55	14.64
6	#10480.00	44.7 AV	54.0	-9.3	1.46 H	164	30.05	14.64

ANTENNA POLARITY & TEST DISTANCE: VERTICAL AT 3 M

NO.	FREQ. (MHz)	EMISSION LEVEL (dBuV/m)	LIMIT (dBuV/m)	MARGIN (dB)	ANTENNA HEIGHT (m)	TABLE ANGLE (Degree)	RAW VALUE (dBuV)	CORRECTION FACTOR (dB/m)
1	*5240.00	103.5 PK			1.26 V	198	100.66	2.81
2	*5240.00	91.7 AV			1.26 V	198	88.90	2.81
3	5350.00	60.8 PK	74.0	-13.2	1.26 V	198	57.62	3.15
4	5350.00	45.7 AV	54.0	-8.3	1.26 V	198	42.56	3.15
5	#10480.00	57.2 PK	74.0	-16.8	1.26 V	200	42.58	14.64
6	#10480.00	45.0 AV	54.0	-9.0	1.26 V	200	30.39	14.64

REMARKS:

- Emission Level(dBuV/m) = Raw Value(dBuV) + Correction Factor(dB/m)
- Correction Factor(dB/m) = Antenna Factor(dB/m) + Cable Factor(dB) – Pre-Amplifier Factor(dB)
- The other emission levels were very low against the limit.
- Margin value = Emission Level – Limit value
- " * ": Fundamental frequency.
- " # ": The radiated frequency is out of the restricted band.

802.11n (20MHz)

CHANNEL	TX Channel 36	DETECTOR FUNCTION	Peak (PK)
FREQUENCY RANGE	1GHz ~ 40GHz		Average (AV)
ANTENNA	A		

ANTENNA POLARITY & TEST DISTANCE: HORIZONTAL AT 3 M								
NO.	FREQ. (MHz)	EMISSION LEVEL (dBuV/m)	LIMIT (dBuV/m)	MARGIN (dB)	ANTENNA HEIGHT (m)	TABLE ANGLE (Degree)	RAW VALUE (dBuV)	CORRECTION FACTOR (dB/m)
1	5150.00	68.8 PK	74.0	-5.3	1.53 H	150	66.04	2.71
2	5150.00	49.5 AV	54.0	-4.5	1.53 H	150	46.80	2.71
3	*5180.00	105.0 PK			1.53 H	150	102.27	2.73
4	*5180.00	95.2 AV			1.53 H	150	92.43	2.73
5	#10360.00	60.6 PK	74.0	-13.5	1.53 H	152	46.27	14.28
6	#10360.00	46.8 AV	54.0	-7.2	1.53 H	152	32.54	14.28

ANTENNA POLARITY & TEST DISTANCE: VERTICAL AT 3 M								
NO.	FREQ. (MHz)	EMISSION LEVEL (dBuV/m)	LIMIT (dBuV/m)	MARGIN (dB)	ANTENNA HEIGHT (m)	TABLE ANGLE (Degree)	RAW VALUE (dBuV)	CORRECTION FACTOR (dB/m)
1	5150.00	71.7 PK	74.0	-2.4	1.26 V	263	68.94	2.71
2	5150.00	51.8 AV	54.0	-2.2	1.26 V	263	49.13	2.71
3	*5180.00	109.0 PK			1.26 V	263	106.24	2.73
4	*5180.00	98.4 AV			1.26 V	263	95.70	2.73
5	#10360.00	64.4 PK	74.0	-9.6	1.26 V	263	50.15	14.28
6	#10360.00	50.7 AV	54.0	-3.3	1.26 V	263	36.45	14.28

REMARKS:

1. Emission Level(dBuV/m) = Raw Value(dBuV) + Correction Factor(dB/m)
2. Correction Factor(dB/m) = Antenna Factor(dB/m) + Cable Factor(dB) – Pre-Amplifier Factor(dB)
3. The other emission levels were very low against the limit.
4. Margin value = Emission Level – Limit value
5. " * ": Fundamental frequency.
6. " # ": The radiated frequency is out of the restricted band.

CHANNEL	TX Channel 40	DETECTOR FUNCTION	Peak (PK)
FREQUENCY RANGE	1GHz ~ 40GHz		Average (AV)
ANTENNA	A		

ANTENNA POLARITY & TEST DISTANCE: HORIZONTAL AT 3 M								
NO.	FREQ. (MHz)	EMISSION LEVEL (dBuV/m)	LIMIT (dBuV/m)	MARGIN (dB)	ANTENNA HEIGHT (m)	TABLE ANGLE (Degree)	RAW VALUE (dBuV)	CORRECTION FACTOR (dB/m)
1	*5200.00	105.0 PK			1.41 H	153	102.25	2.73
2	*5200.00	94.0 AV			1.41 H	153	91.31	2.73
3	#10400.00	62.0 PK	74.0	-12.0	1.41 H	153	47.62	14.39
4	#10400.00	46.4 AV	54.0	-7.6	1.41 H	153	32.04	14.39

ANTENNA POLARITY & TEST DISTANCE: VERTICAL AT 3 M								
NO.	FREQ. (MHz)	EMISSION LEVEL (dBuV/m)	LIMIT (dBuV/m)	MARGIN (dB)	ANTENNA HEIGHT (m)	TABLE ANGLE (Degree)	RAW VALUE (dBuV)	CORRECTION FACTOR (dB/m)
1	*5200.00	109.7 PK			1.25 V	262	106.92	2.73
2	*5200.00	97.8 AV			1.25 V	262	95.08	2.73
3	#10400.00	65.8 PK	74.0	-8.2	1.26 V	262	51.39	14.39
4	#10400.00	49.9 AV	54.0	-4.1	1.26 V	262	35.52	14.39

REMARKS:

1. Emission Level(dBuV/m) = Raw Value(dBuV) + Correction Factor(dB/m)
2. Correction Factor(dB/m) = Antenna Factor(dB/m) + Cable Factor(dB) – Pre-Amplifier Factor(dB)
3. The other emission levels were very low against the limit.
4. Margin value = Emission Level – Limit value
5. " * ": Fundamental frequency.
6. " # ": The radiated frequency is out of the restricted band.

CHANNEL	TX Channel 48	DETECTOR FUNCTION	Peak (PK)
FREQUENCY RANGE	1GHz ~ 40GHz		Average (AV)
ANTENNA	A		

ANTENNA POLARITY & TEST DISTANCE: HORIZONTAL AT 3 M

NO.	FREQ. (MHz)	EMISSION LEVEL (dBuV/m)	LIMIT (dBuV/m)	MARGIN (dB)	ANTENNA HEIGHT (m)	TABLE ANGLE (Degree)	RAW VALUE (dBuV)	CORRECTION FACTOR (dB/m)
1	*5240.00	104.5 PK			1.55 H	159	101.65	2.81
2	*5240.00	90.4 AV			1.55 H	159	87.63	2.81
3	5350.00	57.2 PK	74.0	-16.8	1.55 H	159	54.07	3.15
4	5350.00	43.4 AV	54.0	-10.6	1.55 H	159	40.24	3.15
5	#10480.00	60.8 PK	74.0	-13.2	1.55 H	159	46.18	14.64
6	#10480.00	47.4 AV	54.0	-6.6	1.55 H	159	32.80	14.64

ANTENNA POLARITY & TEST DISTANCE: VERTICAL AT 3 M

NO.	FREQ. (MHz)	EMISSION LEVEL (dBuV/m)	LIMIT (dBuV/m)	MARGIN (dB)	ANTENNA HEIGHT (m)	TABLE ANGLE (Degree)	RAW VALUE (dBuV)	CORRECTION FACTOR (dB/m)
1	*5240.00	109.6 PK			1.25 V	263	106.74	2.81
2	*5240.00	96.3 AV			1.25 V	263	93.51	2.81
3	5350.00	57.5 PK	74.0	-16.6	1.25 V	263	54.30	3.15
4	5350.00	43.4 AV	54.0	-10.6	1.25 V	263	40.26	3.15
5	#10480.00	64.9 PK	74.0	-9.1	1.25 V	264	50.29	14.64
6	#10480.00	49.7 AV	54.0	-4.3	1.25 V	264	35.08	14.64

REMARKS:

1. Emission Level(dBuV/m) = Raw Value(dBuV) + Correction Factor(dB/m)
2. Correction Factor(dB/m) = Antenna Factor(dB/m) + Cable Factor(dB) – Pre-Amplifier Factor(dB)
3. The other emission levels were very low against the limit.
4. Margin value = Emission Level – Limit value
5. " * ": Fundamental frequency.
6. " # ": The radiated frequency is out of the restricted band.

CHANNEL	TX Channel 36	DETECTOR FUNCTION	Peak (PK)
FREQUENCY RANGE	1GHz ~ 40GHz		Average (AV)
ANTENNA	B		

ANTENNA POLARITY & TEST DISTANCE: HORIZONTAL AT 3 M

NO.	FREQ. (MHz)	EMISSION LEVEL (dBuV/m)	LIMIT (dBuV/m)	MARGIN (dB)	ANTENNA HEIGHT (m)	TABLE ANGLE (Degree)	RAW VALUE (dBuV)	CORRECTION FACTOR (dB/m)
1	5150.00	60.4 PK	74.0	-13.6	1.47 H	155	57.72	2.71
2	5150.00	43.0 AV	54.0	-11.0	1.47 H	155	40.30	2.71
3	*5180.00	97.9 PK			1.47 H	155	95.14	2.73
4	*5180.00	86.5 AV			1.47 H	155	83.80	2.73
5	#10360.00	56.6 PK	74.0	-17.4	1.47 H	155	42.35	14.28
6	#10360.00	44.9 AV	54.0	-9.1	1.47 H	155	30.63	14.28

ANTENNA POLARITY & TEST DISTANCE: VERTICAL AT 3 M

NO.	FREQ. (MHz)	EMISSION LEVEL (dBuV/m)	LIMIT (dBuV/m)	MARGIN (dB)	ANTENNA HEIGHT (m)	TABLE ANGLE (Degree)	RAW VALUE (dBuV)	CORRECTION FACTOR (dB/m)
1	5150.00	62.5 PK	74.0	-11.5	1.24 V	178	59.81	2.71
2	5150.00	46.4 AV	54.0	-7.7	1.24 V	178	43.64	2.71
3	*5180.00	103.7 PK			1.24 V	178	100.96	2.73
4	*5180.00	92.5 AV			1.24 V	178	89.80	2.73
5	#10360.00	57.1 PK	74.0	-16.9	1.24 V	180	42.86	14.28
6	#10360.00	44.2 AV	54.0	-9.8	1.24 V	180	29.94	14.28

REMARKS:

1. Emission Level(dBuV/m) = Raw Value(dBuV) + Correction Factor(dB/m)
2. Correction Factor(dB/m) = Antenna Factor(dB/m) + Cable Factor(dB) – Pre-Amplifier Factor(dB)
3. The other emission levels were very low against the limit.
4. Margin value = Emission Level – Limit value
5. " * ": Fundamental frequency.
6. " # ": The radiated frequency is out of the restricted band.

CHANNEL	TX Channel 40	DETECTOR FUNCTION	Peak (PK)
FREQUENCY RANGE	1GHz ~ 40GHz		Average (AV)
ANTENNA	B		

ANTENNA POLARITY & TEST DISTANCE: HORIZONTAL AT 3 M								
NO.	FREQ. (MHz)	EMISSION LEVEL (dBuV/m)	LIMIT (dBuV/m)	MARGIN (dB)	ANTENNA HEIGHT (m)	TABLE ANGLE (Degree)	RAW VALUE (dBuV)	CORRECTION FACTOR (dB/m)
1	*5200.00	98.1 PK			1.47 H	159	95.39	2.73
2	*5200.00	86.9 AV			1.47 H	159	84.13	2.73
3	#10400.00	57.5 PK	74.0	-16.5	1.47 H	159	43.13	14.39
4	#10400.00	45.3 AV	54.0	-8.7	1.47 H	159	30.91	14.39

ANTENNA POLARITY & TEST DISTANCE: VERTICAL AT 3 M								
NO.	FREQ. (MHz)	EMISSION LEVEL (dBuV/m)	LIMIT (dBuV/m)	MARGIN (dB)	ANTENNA HEIGHT (m)	TABLE ANGLE (Degree)	RAW VALUE (dBuV)	CORRECTION FACTOR (dB/m)
1	*5200.00	104.1 PK			1.25 V	177	101.41	2.73
2	*5200.00	93.6 AV			1.25 V	177	90.82	2.73
3	#10400.00	57.4 PK	74.0	-16.6	1.25 V	177	42.99	14.39
4	#10400.00	44.7 AV	54.0	-9.3	1.25 V	177	30.27	14.39

REMARKS:

1. Emission Level(dBuV/m) = Raw Value(dBuV) + Correction Factor(dB/m)
2. Correction Factor(dB/m) = Antenna Factor(dB/m) + Cable Factor(dB) – Pre-Amplifier Factor(dB)
3. The other emission levels were very low against the limit.
4. Margin value = Emission Level – Limit value
5. " * ": Fundamental frequency.
6. " # ": The radiated frequency is out of the restricted band.

CHANNEL	TX Channel 48	DETECTOR FUNCTION	Peak (PK)
FREQUENCY RANGE	1GHz ~ 40GHz		Average (AV)
ANTENNA	B		

ANTENNA POLARITY & TEST DISTANCE: HORIZONTAL AT 3 M

NO.	FREQ. (MHz)	EMISSION LEVEL (dBuV/m)	LIMIT (dBuV/m)	MARGIN (dB)	ANTENNA HEIGHT (m)	TABLE ANGLE (Degree)	RAW VALUE (dBuV)	CORRECTION FACTOR (dB/m)
1	*5240.00	98.6 PK			1.40 H	360	95.82	2.81
2	*5240.00	87.7 AV			1.40 H	360	84.86	2.81
3	5350.00	55.7 PK	74.0	-18.3	1.40 H	150	52.51	3.15
4	5350.00	41.8 AV	54.0	-12.2	1.40 H	150	38.62	3.15
5	#10480.00	56.9 PK	74.0	-17.1	1.40 H	151	42.28	14.64
6	#10480.00	44.9 AV	54.0	-9.1	1.40 H	151	30.29	14.64

ANTENNA POLARITY & TEST DISTANCE: VERTICAL AT 3 M

NO.	FREQ. (MHz)	EMISSION LEVEL (dBuV/m)	LIMIT (dBuV/m)	MARGIN (dB)	ANTENNA HEIGHT (m)	TABLE ANGLE (Degree)	RAW VALUE (dBuV)	CORRECTION FACTOR (dB/m)
1	*5240.00	103.1 PK			1.24 V	177	100.32	2.81
2	*5240.00	92.4 AV			1.24 V	177	89.58	2.81
3	5350.00	58.7 PK	74.0	-15.3	1.24 V	177	55.58	3.15
4	5350.00	46.9 AV	54.0	-7.1	1.24 V	177	43.72	3.15
5	#10480.00	57.2 PK	74.0	-16.8	1.24 V	180	42.54	14.64
6	#10480.00	45.5 AV	54.0	-8.5	1.24 V	180	30.87	14.64

REMARKS:

1. Emission Level(dBuV/m) = Raw Value(dBuV) + Correction Factor(dB/m)
2. Correction Factor(dB/m) = Antenna Factor(dB/m) + Cable Factor(dB) – Pre-Amplifier Factor(dB)
3. The other emission levels were very low against the limit.
4. Margin value = Emission Level – Limit value
5. " * ": Fundamental frequency.
6. " # ": The radiated frequency is out of the restricted band.

802.11n (40MHz)

CHANNEL	TX Channel 38	DETECTOR FUNCTION	Peak (PK)
FREQUENCY RANGE	1GHz ~ 40GHz		Average (AV)
ANTENNA	A		

ANTENNA POLARITY & TEST DISTANCE: HORIZONTAL AT 3 M								
NO.	FREQ. (MHz)	EMISSION LEVEL (dBuV/m)	LIMIT (dBuV/m)	MARGIN (dB)	ANTENNA HEIGHT (m)	TABLE ANGLE (Degree)	RAW VALUE (dBuV)	CORRECTION FACTOR (dB/m)
1	5150.00	72.9 PK	74.0	-1.1	1.57 H	149	70.20	2.71
2	5150.00	52.1 AV	54.0	-1.9	1.57 H	149	49.42	2.71
3	*5190.00	98.6 PK			1.00 H	149	95.85	2.72
4	*5190.00	86.7 AV			1.00 H	149	83.97	2.72
5	#10380.00	61.1 PK	74.0	-12.9	1.57 H	149	46.74	14.34
6	#10380.00	47.1 AV	54.0	-6.9	1.57 H	149	32.76	14.34

ANTENNA POLARITY & TEST DISTANCE: VERTICAL AT 3 M								
NO.	FREQ. (MHz)	EMISSION LEVEL (dBuV/m)	LIMIT (dBuV/m)	MARGIN (dB)	ANTENNA HEIGHT (m)	TABLE ANGLE (Degree)	RAW VALUE (dBuV)	CORRECTION FACTOR (dB/m)
1	5150.00	70.8 PK	74.0	-3.2	1.38 V	264	68.09	2.71
2	5150.00	49.6 AV	54.0	-4.4	1.38 V	264	46.86	2.71
3	*5190.00	104.1 PK			1.38 V	264	101.41	2.72
4	*5190.00	93.4 AV			1.38 V	264	90.69	2.72
5	#10380.00	59.7 PK	74.0	-14.3	1.38 V	261	45.37	14.34
6	#10380.00	46.2 AV	54.0	-7.8	1.38 V	261	31.83	14.34

REMARKS:

1. Emission Level(dBuV/m) = Raw Value(dBuV) + Correction Factor(dB/m)
2. Correction Factor(dB/m) = Antenna Factor(dB/m) + Cable Factor(dB) – Pre-Amplifier Factor(dB)
3. The other emission levels were very low against the limit.
4. Margin value = Emission Level – Limit value
5. " * ": Fundamental frequency.
6. " # ": The radiated frequency is out of the restricted band.

CHANNEL	TX Channel 46	DETECTOR FUNCTION	Peak (PK)
FREQUENCY RANGE	1GHz ~ 40GHz		Average (AV)
ANTENNA	A		

ANTENNA POLARITY & TEST DISTANCE: HORIZONTAL AT 3 M

NO.	FREQ. (MHz)	EMISSION LEVEL (dBuV/m)	LIMIT (dBuV/m)	MARGIN (dB)	ANTENNA HEIGHT (m)	TABLE ANGLE (Degree)	RAW VALUE (dBuV)	CORRECTION FACTOR (dB/m)
1	*5230.00	99.9 PK			1.40 H	160	97.11	2.79
2	*5230.00	89.5 AV			1.40 H	160	86.71	2.79
3	5350.00	58.6 PK	74.0	-15.5	1.40 H	160	55.40	3.15
4	5350.00	44.2 AV	54.0	-9.8	1.40 H	160	41.09	3.15
5	#10460.00	61.3 PK	74.0	-12.7	1.40 H	160	46.74	14.58
6	#10460.00	47.8 AV	54.0	-6.2	1.40 H	160	33.22	14.58

ANTENNA POLARITY & TEST DISTANCE: VERTICAL AT 3 M

NO.	FREQ. (MHz)	EMISSION LEVEL (dBuV/m)	LIMIT (dBuV/m)	MARGIN (dB)	ANTENNA HEIGHT (m)	TABLE ANGLE (Degree)	RAW VALUE (dBuV)	CORRECTION FACTOR (dB/m)
1	*5230.00	103.9 PK			1.38 V	261	101.14	2.79
2	*5230.00	91.9 AV			1.38 V	261	89.12	2.79
3	5350.00	57.6 PK	74.0	-16.4	1.38 V	261	54.45	3.15
4	5350.00	44.4 AV	54.0	-9.6	1.38 V	261	41.25	3.15
5	#10460.00	60.5 PK	74.0	-13.5	1.38 V	261	45.89	14.58
6	#10460.00	46.3 AV	54.0	-7.7	1.38 V	261	31.70	14.58

REMARKS:

1. Emission Level(dBuV/m) = Raw Value(dBuV) + Correction Factor(dB/m)
2. Correction Factor(dB/m) = Antenna Factor(dB/m) + Cable Factor(dB) – Pre-Amplifier Factor(dB)
3. The other emission levels were very low against the limit.
4. Margin value = Emission Level – Limit value
5. " * ": Fundamental frequency.
6. " # ": The radiated frequency is out of the restricted band.

CHANNEL	TX Channel 38	DETECTOR FUNCTION	Peak (PK)
FREQUENCY RANGE	1GHz ~ 40GHz		Average (AV)
ANTENNA	B		

ANTENNA POLARITY & TEST DISTANCE: HORIZONTAL AT 3 M

NO.	FREQ. (MHz)	EMISSION LEVEL (dBuV/m)	LIMIT (dBuV/m)	MARGIN (dB)	ANTENNA HEIGHT (m)	TABLE ANGLE (Degree)	RAW VALUE (dBuV)	CORRECTION FACTOR (dB/m)
1	5150.00	59.6 PK	74.0	-14.4	1.38 H	182	56.92	2.71
2	5150.00	41.0 AV	54.0	-13.0	1.38 H	182	38.28	2.71
3	*5190.00	95.6 PK			1.38 H	172	92.88	2.72
4	*5190.00	84.7 AV			1.38 H	172	81.94	2.72
5	#10380.00	52.5 PK	74.0	-21.5	1.38 H	172	38.19	14.34
6	#10380.00	41.7 AV	54.0	-12.3	1.38 H	172	27.37	14.34

ANTENNA POLARITY & TEST DISTANCE: VERTICAL AT 3 M

NO.	FREQ. (MHz)	EMISSION LEVEL (dBuV/m)	LIMIT (dBuV/m)	MARGIN (dB)	ANTENNA HEIGHT (m)	TABLE ANGLE (Degree)	RAW VALUE (dBuV)	CORRECTION FACTOR (dB/m)
1	5150.00	58.8 PK	74.0	-15.2	1.00 V	215	56.06	2.71
2	5150.00	44.8 AV	54.0	-9.2	1.00 V	215	42.10	2.71
3	*5190.00	97.3 PK			1.00 V	215	94.62	2.72
4	*5190.00	86.8 AV			1.00 V	215	84.08	2.72
5	#10380.00	57.1 PK	74.0	-17.0	1.00 V	220	42.71	14.34
6	#10380.00	46.0 AV	54.0	-8.0	1.00 V	220	31.68	14.34

REMARKS:

1. Emission Level(dBuV/m) = Raw Value(dBuV) + Correction Factor(dB/m)
2. Correction Factor(dB/m) = Antenna Factor(dB/m) + Cable Factor(dB) – Pre-Amplifier Factor(dB)
3. The other emission levels were very low against the limit.
4. Margin value = Emission Level – Limit value
5. " * ": Fundamental frequency.
6. " # ": The radiated frequency is out of the restricted band.

CHANNEL	TX Channel 46	DETECTOR FUNCTION	Peak (PK)
FREQUENCY RANGE	1GHz ~ 40GHz		Average (AV)
ANTENNA	B		

ANTENNA POLARITY & TEST DISTANCE: HORIZONTAL AT 3 M

NO.	FREQ. (MHz)	EMISSION LEVEL (dBuV/m)	LIMIT (dBuV/m)	MARGIN (dB)	ANTENNA HEIGHT (m)	TABLE ANGLE (Degree)	RAW VALUE (dBuV)	CORRECTION FACTOR (dB/m)
1	*5230.00	92.5 PK			1.37 H	170	89.73	2.79
2	*5230.00	80.7 AV			1.37 H	170	77.93	2.79
3	5350.00	53.4 PK	74.0	-20.7	1.37 H	170	50.20	3.15
4	5350.00	39.6 AV	54.0	-14.4	1.37 H	170	36.49	3.15
5	#10460.00	56.3 PK	74.0	-17.7	1.37 H	172	41.72	14.58
6	#10460.00	45.5 AV	54.0	-8.6	1.37 H	172	30.87	14.58

ANTENNA POLARITY & TEST DISTANCE: VERTICAL AT 3 M

NO.	FREQ. (MHz)	EMISSION LEVEL (dBuV/m)	LIMIT (dBuV/m)	MARGIN (dB)	ANTENNA HEIGHT (m)	TABLE ANGLE (Degree)	RAW VALUE (dBuV)	CORRECTION FACTOR (dB/m)
1	*5230.00	97.1 PK			1.00 V	215	94.27	2.79
2	*5230.00	85.5 AV			1.00 V	215	82.74	2.79
3	5350.00	58.5 PK	74.0	-15.5	1.00 V	215	55.39	3.15
4	5350.00	45.5 AV	54.0	-8.6	1.00 V	215	42.30	3.15
5	#10460.00	56.3 PK	74.0	-17.7	1.00 V	215	41.73	14.58
6	#10460.00	45.5 AV	54.0	-8.5	1.00 V	215	30.94	14.58

REMARKS:

1. Emission Level(dBuV/m) = Raw Value(dBuV) + Correction Factor(dB/m)
2. Correction Factor(dB/m) = Antenna Factor(dB/m) + Cable Factor(dB) – Pre-Amplifier Factor(dB)
3. The other emission levels were very low against the limit.
4. Margin value = Emission Level – Limit value
5. " * ": Fundamental frequency.
6. " # ": The radiated frequency is out of the restricted band.

BELOW 1GHz WORST-CASE DATA

802.11a

CHANNEL	TX Channel 36	DETECTOR FUNCTION	Quasi-Peak (QP)
FREQUENCY RANGE	30MHz ~ 1GHz		
ANTENNA	A		

ANTENNA POLARITY & TEST DISTANCE: HORIZONTAL AT 3 M								
NO.	FREQ. (MHz)	EMISSION LEVEL (dBuV/m)	LIMIT (dBuV/m)	MARGIN (dB)	ANTENNA HEIGHT (m)	TABLE ANGLE (Degree)	RAW VALUE (dBuV)	CORRECTION FACTOR (dB/m)
1	65.41	18.0 QP	40.0	-22.0	1.24 H	142	32.69	-14.71
2	132.77	23.4 QP	43.5	-20.1	1.14 H	95	37.99	-14.58
3	199.75	25.1 QP	43.5	-18.4	1.35 H	107	41.29	-16.19
4	243.01	24.2 QP	46.0	-21.8	1.28 H	75	38.52	-14.29
5	276.04	25.9 QP	46.0	-20.1	1.19 H	75	38.65	-12.72
6	479.64	24.4 QP	46.0	-21.7	1.31 H	147	33.39	-9.04
ANTENNA POLARITY & TEST DISTANCE: VERTICAL AT 3 M								
NO.	FREQ. (MHz)	EMISSION LEVEL (dBuV/m)	LIMIT (dBuV/m)	MARGIN (dB)	ANTENNA HEIGHT (m)	TABLE ANGLE (Degree)	RAW VALUE (dBuV)	CORRECTION FACTOR (dB/m)
1	63.32	23.3 QP	40.0	-16.7	1.16 V	91	37.88	-14.62
2	112.94	26.1 QP	43.5	-17.4	1.34 V	162	42.73	-16.59
3	125.51	25.5 QP	43.5	-18.0	1.25 V	93	41.00	-15.49
4	248.36	22.4 QP	46.0	-23.6	1.26 V	125	36.44	-14.01
5	278.51	24.5 QP	46.0	-21.5	1.17 V	109	37.21	-12.70
6	554.04	25.1 QP	46.0	-20.9	1.43 V	169	32.92	-7.82

REMARKS:

1. Emission Level(dBuV/m) = Raw Value(dBuV) + Correction Factor(dB/m)
2. Correction Factor(dB/m) = Antenna Factor(dB/m) + Cable Factor(dB) – Pre-Amplifier Factor(dB)
3. The other emission levels were very low against the limit.
4. Margin value = Emission Level – Limit value

CHANNEL	TX Channel 36	DETECTOR FUNCTION	Quasi-Peak (QP)
FREQUENCY RANGE	30MHz ~ 1GHz		
ANTENNA	B		

ANTENNA POLARITY & TEST DISTANCE: HORIZONTAL AT 3 M								
NO.	FREQ. (MHz)	EMISSION LEVEL (dBuV/m)	LIMIT (dBuV/m)	MARGIN (dB)	ANTENNA HEIGHT (m)	TABLE ANGLE (Degree)	RAW VALUE (dBuV)	CORRECTION FACTOR (dB/m)
1	68.02	18.9 QP	40.0	-21.1	1.15 H	140	34.16	-15.22
2	133.26	21.3 QP	43.5	-22.2	1.34 H	75	35.87	-14.53
3	199.56	25.2 QP	43.5	-18.4	1.26 H	91	41.35	-16.20
4	207.46	25.0 QP	43.5	-18.5	1.13 H	94	41.05	-16.04
5	248.20	25.1 QP	46.0	-20.9	1.28 H	66	39.11	-14.03
6	275.99	26.8 QP	46.0	-19.2	1.42 H	87	39.48	-12.72

ANTENNA POLARITY & TEST DISTANCE: VERTICAL AT 3 M								
NO.	FREQ. (MHz)	EMISSION LEVEL (dBuV/m)	LIMIT (dBuV/m)	MARGIN (dB)	ANTENNA HEIGHT (m)	TABLE ANGLE (Degree)	RAW VALUE (dBuV)	CORRECTION FACTOR (dB/m)
1	61.09	23.8 QP	40.0	-16.2	1.16 V	122	38.25	-14.43
2	113.57	26.2 QP	43.5	-17.3	1.37 V	125	42.79	-16.55
3	121.28	25.7 QP	43.5	-17.8	1.05 V	129	41.48	-15.80
4	254.51	24.5 QP	46.0	-21.5	1.16 V	129	38.33	-13.86
5	276.28	23.9 QP	46.0	-22.1	1.24 V	114	36.61	-12.73
6	554.09	24.5 QP	46.0	-21.5	1.53 V	170	32.28	-7.82

REMARKS:

1. Emission Level(dBuV/m) = Raw Value(dBuV) + Correction Factor(dB/m)
2. Correction Factor(dB/m) = Antenna Factor(dB/m) + Cable Factor(dB) – Pre-Amplifier Factor(dB)
3. The other emission levels were very low against the limit.
4. Margin value = Emission Level – Limit value

4.2 CONDUCTED EMISSION MEASUREMENT

4.2.1 LIMITS OF CONDUCTED EMISSION MEASUREMENT

FREQUENCY OF EMISSION (MHz)	CONDUCTED LIMIT (dB μ V)	
	Quasi-peak	Average
0.15 ~ 0.5	66 to 56	56 to 46
0.5 ~ 5	56	46
5 ~ 30	60	50

- NOTE:** 1. The lower limit shall apply at the transition frequencies.
 2. The limit decreases in line with the logarithm of the frequency in the range of 0.15 to 0.50MHz.

4.2.2 TEST INSTRUMENTS

Description & Manufacturer	Model No.	Serial No.	Cal. Date	Cal. Due
ROHDE & SCHWARZ TEST RECEIVER	ESCS 30	834115/016	Mar. 24, 2014	Mar. 23, 2015
ROHDE & SCHWARZ Artificial Mains Network (For EUT)	ESH2-Z5	828075/003	Sep. 06, 2013	Sep. 05, 2014
LISN With Adapter (for EUT)	AD10	C03Ada-001	Sep. 06, 2013	Sep. 05, 2014
EMCO L.I.S.N. (For peripherals)	3825/2	9504-2359	Jul. 23, 2013	Jul. 22, 2014
SCHWARZBECK Artificial Mains Network (For EUT)	NNLK8129	8129229	May 15, 2013	May 14, 2014
Software	ADT_Cond_V7.3.7	NA	NA	NA
RF cable (JYEBAO)	5D-FB	Cable-C03.01	Sep. 26, 2013	Sep. 25, 2014
LYNICS Terminator (For EMCO LISN)	0900510	E1-01-300	Jan. 17, 2014	Jan. 16, 2015
LYNICS Terminator (For EMCO LISN)	0900510	E1-01-301	Jan. 27, 2014	Jan. 26, 2015

- Notes: 1. The calibration interval of the above test instruments is 12 months and the calibrations are traceable to NML/ROC and NIST/USA.
 2. The test was performed in Shielded Room No. 3.
 3. The VCCI Site Registration No. C-274.

4.2.3 TEST PROCEDURES

- a. The EUT was placed 0.4 meters from the conducting wall of the shielded room with EUT being connected to the power mains through a line impedance stabilization network (LISN). Other support units were connected to the power mains through another LISN. The two LISNs provide 50 ohm/ 50uH of coupling impedance for the measuring instrument.
- b. Both lines of the power mains connected to the EUT were checked for maximum conducted interference.
- c. The frequency range from 150kHz to 30MHz was searched. Emission levels under (Limit - 20dB) was not recorded.

NOTE: All modes of operation were investigated and the worst-case emissions are reported.

4.2.4 DEVIATION FROM TEST STANDARD

No deviation.

4.2.5 TEST SETUP

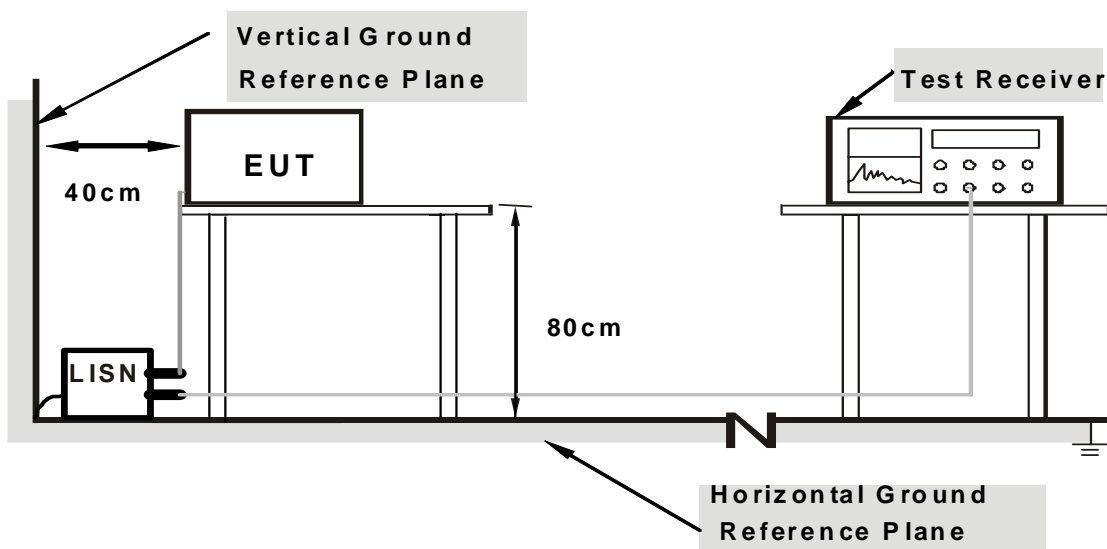

Note: Support units were connected to second LISN.

For the actual test configuration, please refer to the attached file (Test Setup Photo).

4.2.6 EUT OPERATING CONDITIONS

- a. Connected the EUT to monitor.
- b. Set the EUT under transmitting condition.

4.2.7 TEST RESULTS

CONDUCTED WORST-CASE DATA : 802.11a

PHASE	Line 1	6dB BANDWIDTH	9kHz
-------	--------	---------------	------

No	Freq. [MHz]	Corr. Factor (dB)	Reading Value [dB (uV)]		Emission Level [dB (uV)]		Limit [dB (uV)]		Margin (dB)	
			Q.P.	AV.	Q.P.	AV.	Q.P.	AV.	Q.P.	AV.
1	0.15000	0.24	49.36	26.85	49.60	27.09	66.00	56.00	-16.40	-28.91
2	0.25938	0.27	39.88	19.68	40.15	19.95	61.45	51.45	-21.31	-31.51
3	0.47422	0.28	35.18	28.43	35.46	28.71	56.44	46.44	-20.98	-17.73
4	0.95078	0.31	22.65	11.85	22.96	12.16	56.00	46.00	-33.04	-33.84
5	2.66406	0.42	25.33	19.32	25.75	19.74	56.00	46.00	-30.25	-26.26
6	11.96875	0.56	28.97	21.30	29.53	21.86	60.00	50.00	-30.47	-28.14

REMARKS:

1. Q.P. and AV. are abbreviations of quasi-peak and average individually.
2. The emission levels of other frequencies were very low against the limit.
3. Margin value = Emission Level – Limit value
4. Correction Factor = Insertion loss + Cable loss
5. Emission Level = Correction Factor + Reading Value

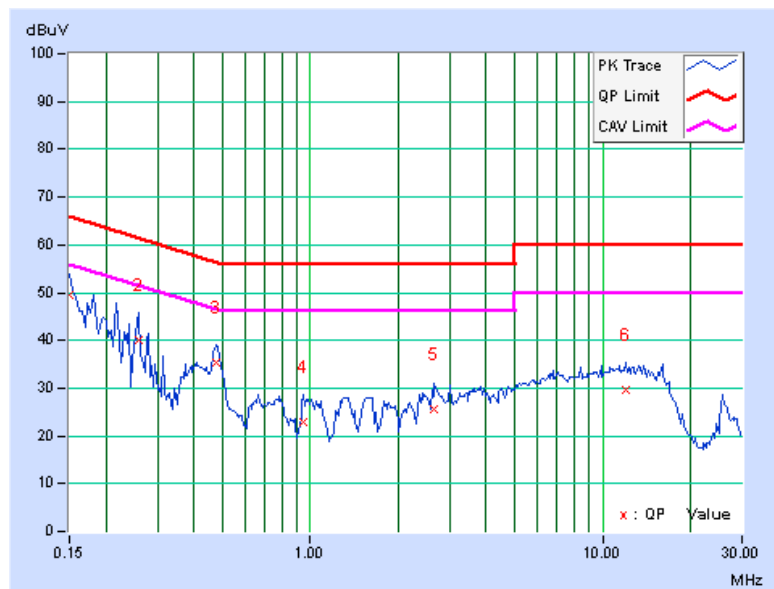



PHASE	Line 2	6dB BANDWIDTH	9kHz
--------------	--------	----------------------	------

No	Freq.	Corr. Factor	Reading Value		Emission Level		Limit		Margin	
	[MHz]		[dB (uV)]		[dB (uV)]		[dB (uV)]		(dB)	
			Q.P.	AV.	Q.P.	AV.	Q.P.	AV.	Q.P.	AV.
1	0.16562	0.31	41.41	25.83	41.72	26.14	65.18	55.18	-23.46	-29.04
2	0.48068	0.37	41.88	40.98	42.25	41.35	56.33	46.33	-14.07	-4.97
3	0.95078	0.39	30.03	27.85	30.42	28.24	56.00	46.00	-25.58	-17.76
4	2.12109	0.53	29.25	25.72	29.78	26.25	56.00	46.00	-26.22	-19.75
5	4.89453	0.58	27.34	22.21	27.92	22.79	56.00	46.00	-28.08	-23.21
6	10.95703	0.59	23.44	18.22	24.03	18.81	60.00	50.00	-35.97	-31.19

REMARKS:

1. Q.P. and AV. are abbreviations of quasi-peak and average individually.
2. The emission levels of other frequencies were very low against the limit.
3. Margin value = Emission Level – Limit value
4. Correction Factor = Insertion loss + Cable loss
5. Emission Level = Correction Factor + Reading Value

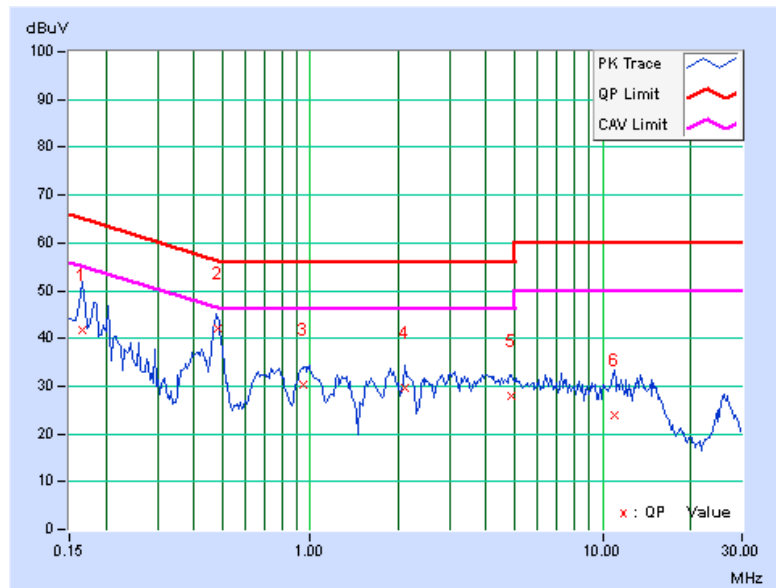

4.3 PEAK TRANSMIT POWER MEASUREMENT

4.3.1 LIMITS OF PEAK TRANSMIT POWER MEASUREMENT

FREQUENCY BAND	LIMIT
5.150 ~ 5.250GHz	The lesser of 50mW (17dBm) or 4dBm + 10logB

NOTE: Where B is the 26dB emission bandwidth in MHz.

4.3.2 TEST SETUP

FOR POWER OUTPUT MEASUREMENT

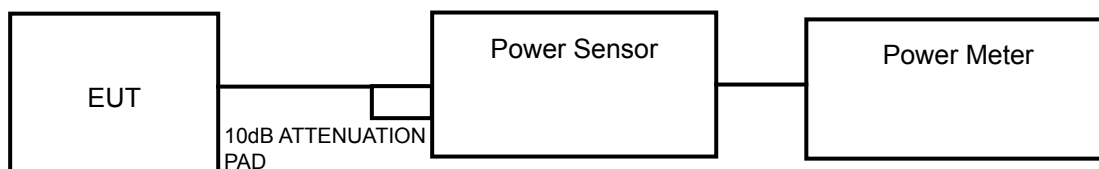

FOR 26dB BANDWIDTH

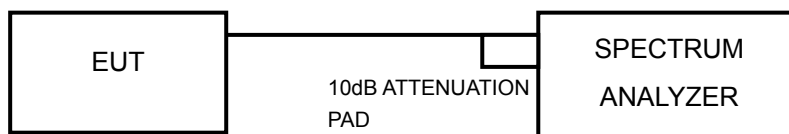

4.3.3 TEST INSTRUMENTS

Refer to section 4.1.3 to get information of above instrument.

4.3.4 TEST PROCEDURE

FOR AVERAGE POWER MEASUREMENT

Method PM is used to perform output power measurement, trigger and gating function of wide band power meter is enabled to measure max output power of TX on burst. Duty factor is not added to measured value.

FOR 26dB BANDWIDTH

- 1) Set RBW = approximately 1% of the emission bandwidth.
- 2) Set the VBW > RBW.
- 3) Detector = Peak.
- 4) Trace mode = max hold.
- 5) Measure the maximum width of the emission that is 26 dB down from the peak of the emission. Compare this with the RBW setting of the analyzer. Readjust RBW and repeat measurement as needed until the RBW/EBW ratio is approximately 1%.

4.3.5 DEVIATION FROM TEST STANDARD

No deviation.

4.3.6 EUT OPERATING CONDITIONS

The software provided by client to enable the EUT under transmission condition continuously at specific channel frequencies individually.

4.3.7 TEST RESULTS

POWER OUTPUT:

802.11a

CHANNEL	CHANNEL FREQUENCY (MHz)	AVERAGE POWER (dBm)	AVERAGE POWER (mW)	POWER LIMIT (dBm)	PASS/FAIL
36	5180	12.74	18.8	17.00	PASS
40	5200	12.68	18.5	16.94	PASS
48	5240	12.51	17.8	17.00	PASS

1. $4\text{dBm} + 10\log(20.00) = 17.01\text{ dBm} > 17\text{dBm}$.
2. $4\text{dBm} + 10\log(19.68) = 16.94\text{ dBm} < 17\text{dBm}$.
3. $4\text{dBm} + 10\log(22.70) = 17.56\text{ dBm} > 17\text{dBm}$.

802.11n (20MHz)

CHANNEL	CHANNEL FREQUENCY (MHz)	AVERAGE POWER (dBm)	AVERAGE POWER (mW)	POWER LIMIT (dBm)	PASS/FAIL
36	5180	12.67	18.5	17.00	PASS
40	5200	12.60	18.2	17.00	PASS
48	5240	12.58	18.1	16.96	PASS

1. $4\text{dBm} + 10\log(22.29) = 17.48\text{ dBm} > 17\text{dBm}$.
2. $4\text{dBm} + 10\log(23.45) = 17.70\text{ dBm} > 17\text{dBm}$.
3. $4\text{dBm} + 10\log(19.78) = 16.96\text{ dBm} < 17\text{dBm}$.

802.11n (40MHz)

CHANNEL	CHANNEL FREQUENCY (MHz)	AVERAGE POWER (dBm)	AVERAGE POWER (mW)	POWER LIMIT (dBm)	PASS/FAIL
38	5190	9.82	9.6	17.00	PASS
46	5230	9.78	9.5	17.00	PASS

1. $4\text{dBm} + 10\log(54.88) = 21.39\text{ dBm} > 17\text{dBm}$.
2. $4\text{dBm} + 10\log(43.46) = 20.38\text{ dBm} > 17\text{dBm}$.



A D T

26dB BANDWIDTH:

CHANNEL	CHANNEL FREQUENCY (MHz)	26dBc BANDWIDTH (MHz)	PASS / FAIL
802.11a			
36	5180	20.00	PASS
40	5200	19.68	PASS
48	5240	22.70	PASS
802.11n (20MHz)			
36	5180	22.29	PASS
40	5200	23.45	PASS
48	5240	19.78	PASS
802.11n (40MHz)			
38	5190	54.88	PASS
46	5230	43.46	PASS

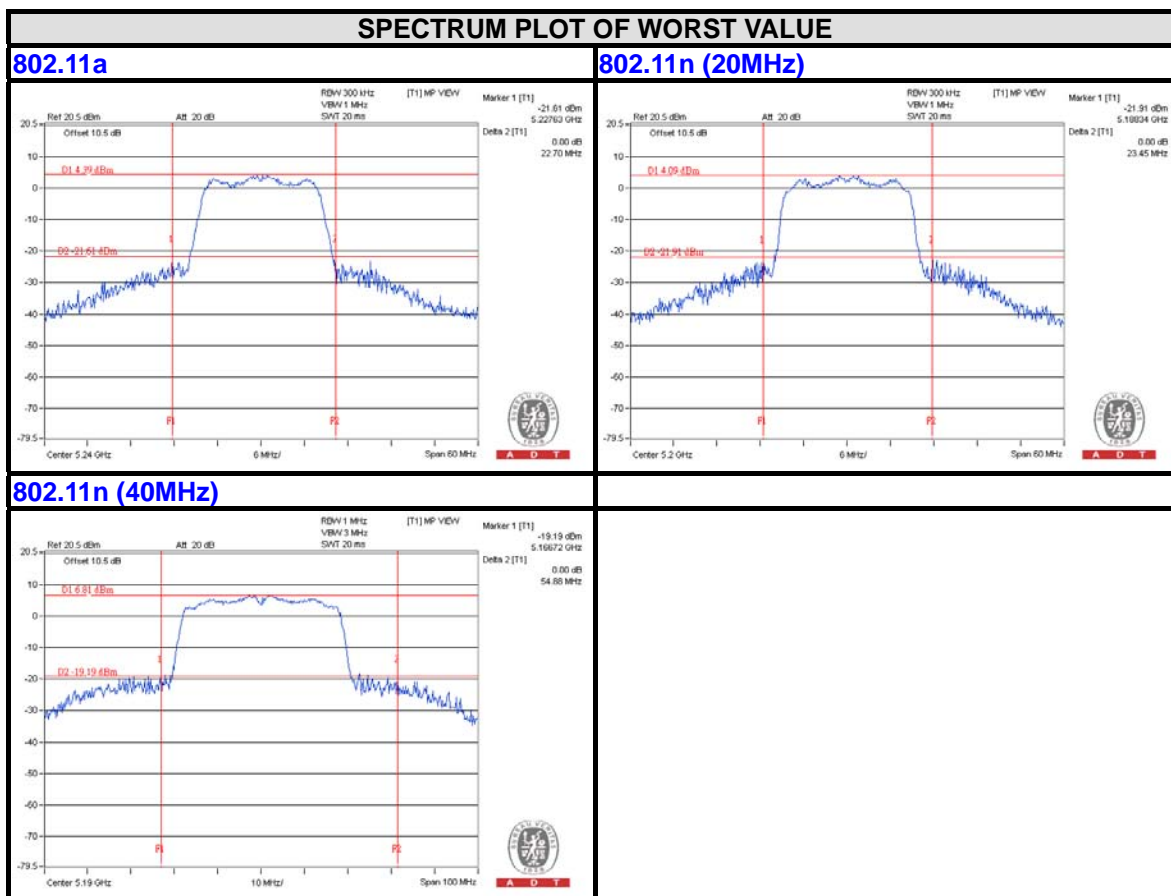

4.4 PEAK POWER SPECTRAL DENSITY MEASUREMENT

4.4.1 LIMITS OF PEAK POWER SPECTRAL DENSITY MEASUREMENT

FREQUENCY BAND	LIMIT
5.150 ~ 5.250GHz	4dBm

4.4.2 TEST SETUP

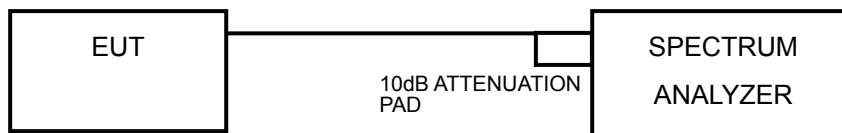

4.4.3 TEST INSTRUMENTS

Refer to section 4.1.3 to get information of above instrument.

4.4.4 TEST PROCEDURES

Using method SA-2

- 1) Set span to encompass the entire emission bandwidth (EBW) of the signal.
- 2) Set RBW = 30 KHz, Set VBW \geq 1 MHz, Detector = RMS
- 3) Set Channel power measure = 1MHz
- 4) Sweep time = auto, trigger set to "free run".
- 5) Trace average at least 100 traces in power averaging mode.
- 6) Record the max value and add $10 \log (1/\text{duty cycle})$

4.4.5 DEVIATION FROM TEST STANDARD

No deviation.

4.4.6 EUT OPERATING CONDITIONS

Same as 4.3.6.



4.4.7 TEST RESULTS

802.11a

CHANNEL	FREQUENCY (MHz)	PSD W/O DUTY FACTOR (dBm)	DUTY FACTOR	PSD WITH DUTY FACTOR (dBm)	MAXIMUM LIMIT (dBm)	PASS/FAIL
36	5180	-1.62	0.29	-1.33	4	PASS
40	5200	-1.33	0.29	-1.04	4	PASS
48	5240	-1.54	0.29	-1.25	4	PASS

802.11n (20MHz)

CHANNEL	FREQUENCY (MHz)	PSD W/O DUTY FACTOR (dBm)	DUTY FACTOR	PSD WITH DUTY FACTOR (dBm)	MAXIMUM LIMIT (dBm)	PASS/FAIL
36	5180	-1.48	0.25	-1.23	4	PASS
40	5200	-0.98	0.25	-0.73	4	PASS
48	5240	-1.33	0.25	-1.08	4	PASS

802.11n (40MHz)

CHANNEL	FREQUENCY (MHz)	PSD W/O DUTY FACTOR (dBm)	DUTY FACTOR	PSD WITH DUTY FACTOR (dBm)	MAXIMUM LIMIT (dBm)	PASS/FAIL
38	5190	-5.55	0.48	-5.07	4	PASS
46	5230	-5.53	0.48	-5.05	4	PASS

NOTE: Refer to section 3.3 for duty cycle spectrum plot.



A D T

SPECTRUM PLOT OF WORST VALUE

802.11a

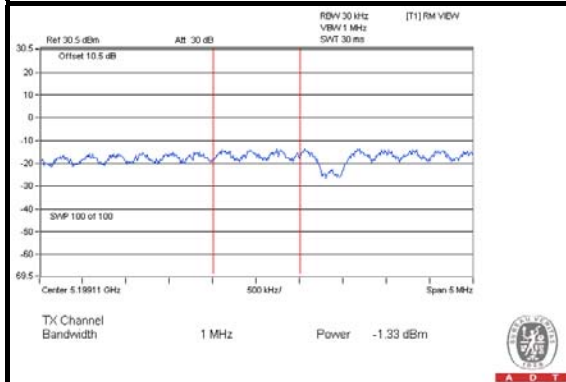

802.11n (20MHz)

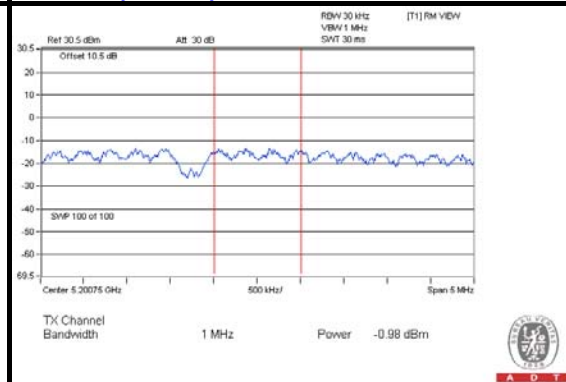

802.11n (40MHz)

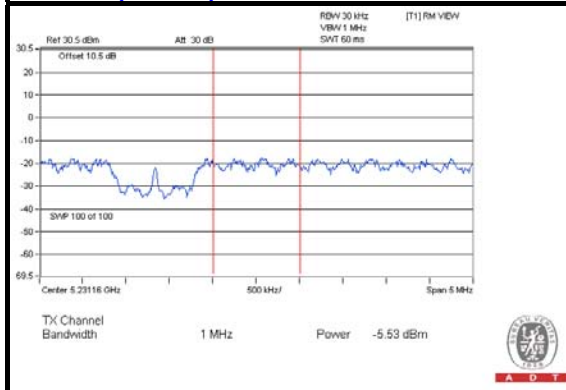

4.5 PEAK POWER EXCURSION MEASUREMENT

4.5.1 LIMITS OF PEAK POWER EXCURSION MEASUREMENT

Shall not exceed 13 dB.

4.5.2 TEST SETUP

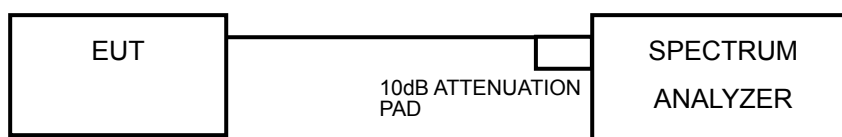

4.5.3 TEST INSTRUMENTS

Refer to section 4.1.3 to get information of above instrument.

4.5.4 TEST PROCEDURE

- 1) Set RBW = 1 MHz, VBW \geq 3 MHz, Detector = peak.
- 2) Trace mode = max-hold. Allow the sweeps to continue until the trace stabilizes.
- 3) Use the peak search function to find the peak of the spectrum.
- 4) Measure the PPSD.
- 5) Compute the ratio of the maximum of the peak-max-hold spectrum to the PPSD.
Find the worst channel and modulation mode as above test procedure, and follow KDB 789033 D01 General UNII Test Procedures v01r03 and repeat step 1 to 5 for final testing of each modulation mode on a single channel (all modulation types) in a single operating band to compliance with the peak excursion requirement.

4.5.5 DEVIATION FROM TEST STANDARD

No deviation.

4.5.6 EUT OPERATING CONDITIONS

Same as 4.2.6



4.5.7 TEST RESULTS

MODULATION MODE	MODULATION TYPE	CHAN. FREQ. (MHz)	PEAK VALUE (dBm)	PPSD WITHOUT DUTY FACTOR (dBm)	PPSD WITH DUTY FACTOR (dBm)	PEAK EXCURSION (dB)	LIMIT (dB)	PASS /FAIL
802.11a	BPSK	5180	10.35	-1.62	-1.33	11.68	13	PASS
	QPSK		11.21	-0.04	0.26	10.95	13	PASS
	16QAM		12.10	-0.04	0.26	11.84	13	PASS
	64QAM		11.57	-0.22	0.36	11.21	13	PASS
802.11n (20MHz)	BPSK	5180	10.08	-1.48	-1.23	11.31	13	PASS
	QPSK		11.19	-0.19	0.09	11.10	13	PASS
	16QAM		11.70	-0.11	0.29	11.41	13	PASS
	64QAM		11.35	-0.34	0.25	11.10	13	PASS
802.11n (40MHz)	BPSK	5190	6.84	-5.55	-5.07	11.91	13	PASS
	QPSK		8.04	-4.23	-3.67	11.71	13	PASS
	16QAM		8.35	-3.85	-2.79	11.14	13	PASS
	64QAM		8.45	-4.46	-3.28	11.73	13	PASS

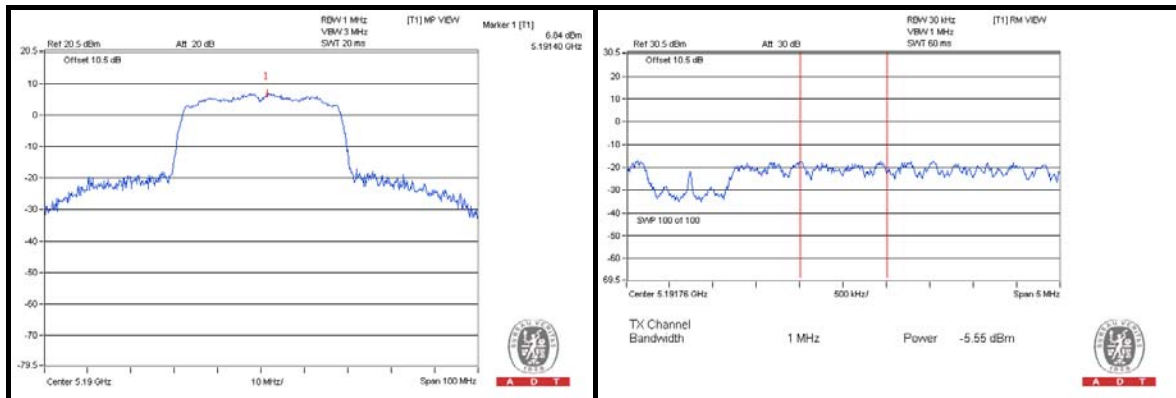

4.6 FREQUENCY STABILITY

4.6.1 LIMITS OF FREQUENCY STABILITY MEASUREMENT

The frequency of the carrier signal shall be maintained within band of operation

4.6.2 TEST SETUP

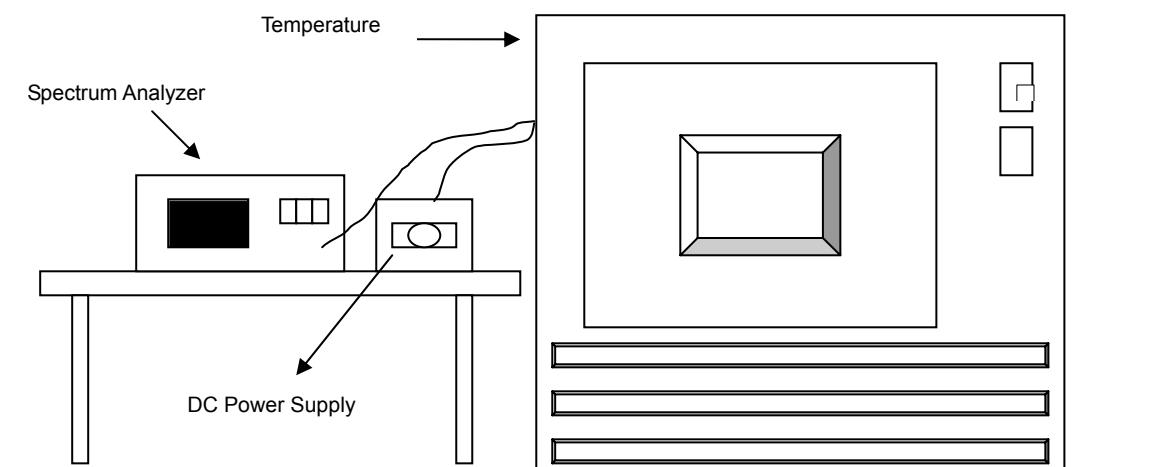

4.6.3 TEST INSTRUMENTS

Refer to section 4.1.3 to get information of above instrument.

4.6.4 TEST PROCEDURE

- a. The EUT was placed inside the environmental test chamber and powered by nominal DC voltage.
- b. Turn the EUT on and couple its output to a spectrum analyzer.
- c. Turn the EUT off and set the chamber to the highest temperature specified.
- d. Allow sufficient time (approximately 30 min) for the temperature of the chamber to stabilize, turn the EUT on and measure the operating frequency after 2, 5, and 10 minutes.
- e. Repeat step 2 and 3 with the temperature chamber set to the lowest temperature.
- f. The test chamber was allowed to stabilize at +20 degree C for a minimum of 30 minutes. The supply voltage was then adjusted on the EUT from 85% to 115% and the frequency record.

4.6.5 DEVIATION FROM TEST STANDARD

No deviation.

4.6.6 EUT OPERATING CONDITION

Set the EUT transmit at un-modulation mode to test frequency stability.

4.6.7 TEST RESULTS

FREQUENCY STABILITY VERSUS TEMP.									
OPERATING FREQUENCY: 5180MHz									
TEMP. (°C)	POWER SUPPLY (Vdc)	0 MINUTE		2 MINUTE		5 MINUTE		10 MINUTE	
		Measured Frequency (MHz)	Frequency Drift (ppm)	Measured Frequency (MHz)	Frequency Drift (ppm)	Measured Frequency (MHz)	Frequency Drift (ppm)	Measured Frequency (MHz)	Frequency Drift (ppm)
55	5.0	5180.042859	8.2739382	5180.042949	8.2913127	5180.042820	8.2664093	5180.043167	8.3333977
50	5.0	5180.042591	8.2222008	5180.04271	8.2451737	5180.043051	8.3110039	5180.042689	8.2411197
40	5.0	5180.042842	8.2706564	5180.042668	8.2370656	5180.042788	8.2602317	5180.04262	8.2277992
30	5.0	5180.04265	8.2335907	5180.042897	8.2812741	5180.042806	8.2637066	5180.042801	8.2627413
20	5.0	5180.042739	8.2507722	5180.042533	8.2110039	5180.042831	8.2685328	5180.042802	8.2629344
10	5.0	5180.04303	8.3069498	5180.043182	8.3362934	5180.042833	8.2689189	5180.043367	8.3720077
0	5.0	5180.042934	8.2884170	5180.042672	8.2378378	5180.042953	8.2920849	5180.042886	8.2791506
-10	5.0	5180.042656	8.2347490	5180.042741	8.2511583	5180.042933	8.2882239	5180.042666	8.2366795
-20	5.0	5180.042642	8.2320463	5180.042828	8.2679537	5180.042820	8.2664093	5180.042624	8.2286457

FREQUENCY STABILITY VERSUS VOLTAGE									
OPERATING FREQUENCY: 5180MHz									
TEMP. (°C)	POWER SUPPLY (Vdc)	0 MINUTE		2 MINUTE		5 MINUTE		10 MINUTE	
		Measured Frequency (MHz)	Frequency Drift (ppm)	Measured Frequency (MHz)	Frequency Drift (ppm)	Measured Frequency (MHz)	Frequency Drift (ppm)	Measured Frequency (MHz)	Frequency Drift (ppm)
20	5.75	5180.043115	8.3233591	5180.042825	8.2673745	5180.042836	8.2694981	5180.042768	8.2563707
	5.0	5180.042739	8.2507722	5180.042533	8.2110039	5180.042831	8.2685328	5180.042802	8.2629344
	4.25	5180.043068	8.3142857	5180.042847	8.2716216	5180.042684	8.2401544	5180.042637	8.2310811

5. PHOTOGRAPHS OF THE TEST CONFIGURATION

Please refer to the attached file (Test Setup Photo).



6. INFORMATION ON THE TESTING LABORATORIES

We, Bureau Veritas Consumer Products Services (H.K.) Ltd., Taoyuan Branch, were founded in 1988 to provide our best service in EMC, Radio, Telecom and Safety consultation. Our laboratories are accredited and approved according to ISO/IEC 17025.

If you have any comments, please feel free to contact us at the following:

Linko EMC/RF Lab:
Tel: 886-2-26052180
Fax: 886-2-26051924

Hsin Chu EMC/RF Lab:
Tel: 886-3-5935343
Fax: 886-3-5935342

Hwa Ya EMC/RF/Safety Telecom Lab:
Tel: 886-3-3183232
Fax: 886-3-3270892

Email: service.adt@tw.bureauveritas.com
Web Site: www.bureauveritas-adt.com

The address and road map of all our labs can be found in our web site also.

7. APPENDIX A – MODIFICATIONS RECORDERS FOR ENGINEERING CHANGES TO THE EUT BY THE LAB

No modifications were made to the EUT by the lab during the test.

---END---