

FCC EMC Test Report

Project No. : 2004C109
Equipment : qico pad
Brand Name : qico
Test Model : QPP-C1
Series Model : QPP-C101, QPP-C102, QPP-C103
Applicant : I/O INTERCONNECT INC.
Address : 5F, No.19-3, Sanchong Rd., Nangang District, Taipei, Taiwan
Manufacturer : I/O INTERCONNECT INC.
Address : 5F, No.19-3, Sanchong Rd., Nangang District, Taipei, Taiwan
Factory : Jiangu InvisPower Co., Ltd.
Address : 100 Xinning Road, Gangzha District, Nantong, Jiangsu, China
Date of Receipt : Apr. 18, 2020
Date of Test : Apr. 22, 2020 ~ May 21, 2020
Issued Date : Jun. 05, 2020
Report Version : R00
Test Sample : Engineering Sample No.: DG2020042026
Standard(s) : FCC Part 18

The above equipment has been tested and found compliance with the requirement of the relative standards by BTL Inc.

Carr Zhang

Prepared by : Carr Zhang

Kevin Li

Approved by : Kevin Li



Certificate #5123.02

Add: No.3, Jinshagang 1st Road, Shixia, Dalang Town, Dongguan, Guangdong, China.

Tel: +86-769-8318-3000

Web: www.newbtl.com

Declaration

BTL represents to the client that testing is done in accordance with standard procedures as applicable and that test instruments used has been calibrated with standards traceable to international standard(s) and/or national standard(s).

BTL's reports apply only to the specific samples tested under conditions. It is manufacture's responsibility to ensure that additional production units of this model are manufactured with the identical electrical and mechanical components. **BTL** shall have no liability for any declarations, inferences or generalizations drawn by the client or others from **BTL** issued reports.

The report must not be used by the client to claim product certification, approval, or endorsement by NIST, A2LA, or any agency of the U.S. Government.

This report is the confidential property of the client. As a mutual protection to the clients, the public and ourselves, the test report shall not be reproduced, except in full, without our written approval.

BTL's laboratory quality assurance procedures are in compliance with the **ISO/IEC 17025** requirements, and accredited by the conformity assessment authorities listed in this test report.

BTL is not responsible for the sampling stage, so the results only apply to the sample as received.

The information, data and test plan are provided by manufacturer which may affect the validity of results, so it is manufacturer's responsibility to ensure that the apparatus meets the essential requirements of applied standards and in all the possible configurations as representative of its intended use.

Limitation

For the use of the authority's logo is limited unless the Test Standard(s)/Scope(s)/Item(s) mentioned in this test report is (are) included in the conformity assessment authorities acceptance respective.

Please note that the measurement uncertainty is provided for informational purpose only and are not use in determining the Pass/Fail results.

Table of Contents	Page
REPORT ISSUED HISTORY	4
1 . SUMMARY OF TEST RESULTS	5
1.1 TEST FACILITY	6
1.2 MEASUREMENT UNCERTAINTY	6
1.3 TEST ENVIRONMENT CONDITIONS	6
2 . GENERAL INFORMATION	7
2.1 GENERAL DESCRIPTION OF EUT	7
2.2 DESCRIPTION OF TEST MODES	8
2.3 EUT OPERATING CONDITIONS	9
2.4 BLOCK DIAGRAM SHOWING THE CONFIGURATION OF SYSTEM TESTED	9
2.5 DESCRIPTION OF SUPPORT UNITS	9
3 . EMC EMISSION TEST	10
3.1 AC POWER LINE CONDUCTED EMISSIONS TEST	10
3.1.1 LIMIT	10
3.1.2 MEASUREMENT INSTRUMENTS LIST	10
3.1.3 TEST PROCEDURE	11
3.1.4 DEVIATION FROM TEST STANDARD	11
3.1.5 TEST SETUP	11
3.1.6 TEST RESULTS	11
3.2 RADIATED EMISSIONS	14
3.2.1 LIMITS	14
3.2.2 MEASUREMENT INSTRUMENTS LIST	14
3.2.3 TEST PROCEDURE	14
3.2.4 DEVIATION FROM TEST STANDARD	15
3.2.5 TEST SETUP	15
3.2.6 TEST RESULTS-9 KHZ to 30 MHZ	15
4 . EUT TEST PHOTO	18

REPORT ISSUED HISTORY

Report Version	Description	Issued Date
R00	Original Issue.	Jun. 05, 2020

1. SUMMARY OF TEST RESULTS

Emission		
Ref Standard(s)	Test Item	Result
FCC/OST MP-5 (1986)	AC Power Line Conducted Emissions	PASS
	Radiated emission 9kHz to 30MHz	PASS
	Radiated emission between 30MHz and 1000MHz	N/A
	Radiated emission Above 1 GHz	N/A

NOTE:

(1) "N/A" denotes test is not applicable to this device.

1.1 TEST FACILITY

The test facilities used to collect the test data in this report at the location of No.3, Jinshagang 1st Road, Shixia, Dalang Town, Dongguan, Guangdong, China.

BTL's Test Firm Registration Number for FCC: 357015

BTL's Designation Number for FCC: CN1240

1.2 MEASUREMENT UNCERTAINTY

ISO/IEC 17025 requires that an estimate of the measurement uncertainties associated with the emissions test results be included in the report. The measurement uncertainties given below are based on a 95% confidence level (based on a coverage factor (k=2))

The BTL measurement uncertainty as below table:

A. AC power line conducted emissions test:

Test Site	Method	Measurement Frequency Range	U,(dB)
DG-C01	CISPR	150kHz ~ 30MHz	2.90

B. Radiated emissions test:

Test Site	Method	Measurement Frequency Range	U,(dB)
DG-CB01	CISPR	9kHz ~ 30MHz	2.46

Note: Unless specifically mentioned, the uncertainty of measurement has not been taken into account to declare the compliance or non-compliance to the specification.

1.3 TEST ENVIRONMENT CONDITIONS

Test Item	Temperature	Humidity	Tested By
AC Power Line Conducted Emissions	25°C	53%	Bang Liang
Radiated emissions 9kHz to 30MHz	25°C	60%	Promise Yin

2. GENERAL INFORMATION

2.1 GENERAL DESCRIPTION OF EUT

Equipment	qico pad
Brand Name	qico
Test Model	QPP-C1
Series Model	QPP-C101, QPP-C102, QPP-C103
Model Difference(s)	Only differ in appearance color.
Power Source	DC voltage supplied from AC adapter (Support Unit).
Power Rating	I/P: 100-240V~ 50/60Hz 0.5A MAX O/P: 5V $\overline{=}$ 3A / 9V $\overline{=}$ 2A / 12V $\overline{=}$ 1.5A
Connecting I/O Port(s)	1* Type-C port
Highest Internal Frequency(Fx)	127.6 kHz

Note:

1. For a more detailed features description, please refer to the manufacturer's specifications or the user's manual.

2.2 DESCRIPTION OF TEST MODES

To investigate the maximum EMI emission characteristics generates from EUT, the test system was pre-scanning tested base on the consideration of following EUT operation mode or test configuration mode which possible have effect on EMI emission level. Each of these EUT operation mode(s) or test configuration mode(s) mentioned above was evaluated respectively.

Pretest Mode	Description
Mode 1	Wireless Discharging+Data R/W+BT+hotspot(12V/1.5A/15W)
Mode 2	Wireless Discharging+Data R/W+BT+hotspot (9V/2A/10W)
Mode 3	Wireless Discharging+Data R/W+BT+hotspot (5V/3A/5W)

AC Power Line Conducted Emissions test	
Final Test Mode	Description
Mode 1	Wireless Discharging+Data R/W+BT+hotspot(12V/1.5A/15W)

Radiated Emissions 9kHz to 30MHz test	
Final Test Mode	Description
Mode 1	Wireless Discharging+Data R/W+BT+hotspot(12V/1.5A/15W)

Note:

1. Pretest Mode 1-3, the worst case is Mode 1 and recorded in this report.

2.3 EUT OPERATING CONDITIONS

The EUT exercise program used during radiated and/or conducted emission measurement was designed to exercise the various system components in a manner similar to a typical use. The standard test signals and output signal as following:

1. EUT connected to Adapter via USB Type-C Cable.
2. EUT places the Load on a wireless charging device.
3. EUT connected to Notebook(A) & Mobile Phone via BT function.
4. EUT connected to Notebook(B) via Hotspot function.
5. Router connected to Mobile Phone & Notebook(A) via WIFI function.

2.4 BLOCK DIAGRAM SHOWING THE CONFIGURATION OF SYSTEM TESTED

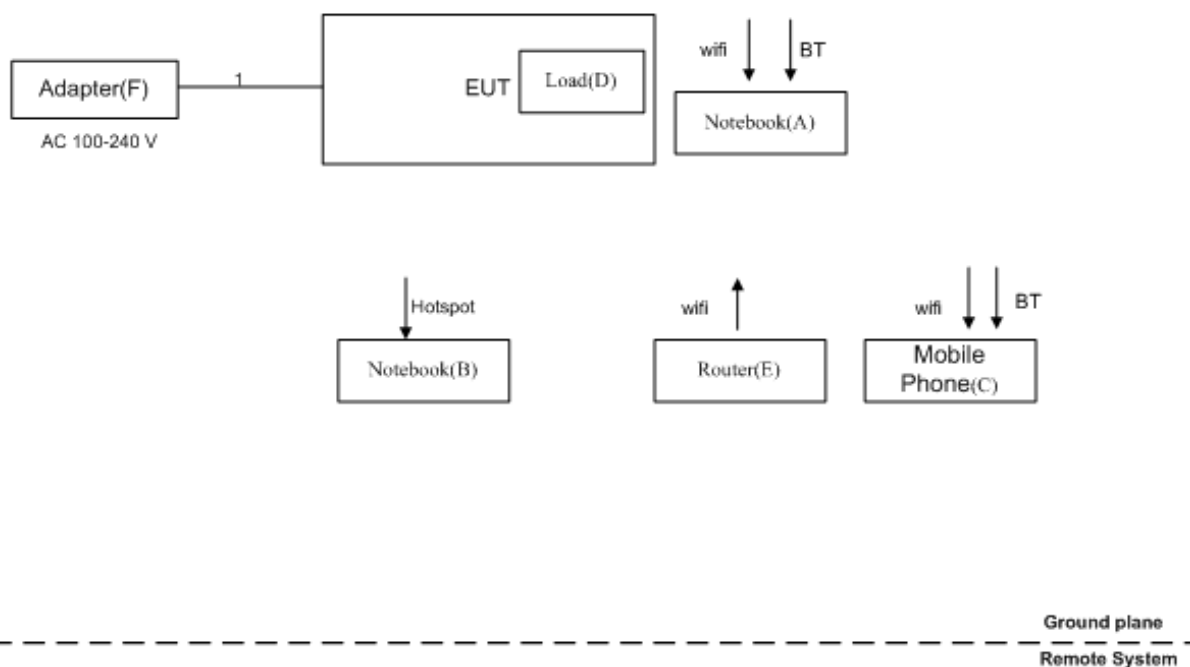

2.5 DESCRIPTION OF SUPPORT UNITS

The EUT has been tested as an independent unit together with other necessary accessories or support units. The following support units or accessories were used to form a representative test configuration during the tests.

Item	Equipment	Mfr/Brand	Model/Type No.	Series No.
A	Notebook	Lenovo	Air 13IWL	MP1GSLN8
B	Notebook	Lenovo	7000-14IKBR	PF1L8WQG
C	Mobile Phone	APPLE	MQA82ZP/A	G6TWW7UDJCL6
D	Load	N/A	N/A	N/A
E	Router	TP-LINK	TL-WR1041N	1142123O01143
F	Adapter	N/A	N/A	N/A

Item	Cable Type	Shielded Type	Ferrite Core	Length
1	USB Type-C Cable	YES	NO	1.5m

3. EMC EMISSION TEST

3.1 AC POWER LINE CONDUCTED EMISSIONS TEST

3.1.1 LIMIT

Frequency of Emission (MHz)	(dBuV)	
	Quasi-peak	Average
0.15 - 0.5	66 to 56 *	56 to 46 *
0.5 - 5.0	56.00	46.00
5.0 - 30.0	60.00	50.00

Note:

- (1) The tighter limit applies at the band edges.
- (2) The limit of " * " marked band means the limitation decreases linearly with the logarithm of the frequency in the range.
- (3) The test result calculated as following:
 Measurement Value = Reading Level + Correct Factor
 Correct Factor = Insertion Loss + Cable Loss + Attenuator Factor(if use)
 Margin Level = Measurement Value - Limit Value

3.1.2 MEASUREMENT INSTRUMENTS LIST

Item	Kind of Equipment	Manufacturer	Type No.	Serial No.	Calibrated until
1	50Ω Terminator	SHX	TF2-3G-A	8122901	Feb. 28, 2021
2	TWO-LINE V-NETWORK	R&S	ENV216	100526	Mar. 01, 2021
3	EMI Test Receiver	R&S	ESR3	101862	Aug. 03, 2020
4	Artificial-Mains Network	SCHWARZBECK	NSLK 8127	8127685	Mar. 01, 2021
5	TRANSIENT LIMITER	EM	EM-7600	772	Mar. 01, 2021
6	Cable	N/A	RG400	N/A(12m)	Mar. 10, 2021
7	Measurement Software	Farad	EZ-EMC Ver.NB-03A1-01	N/A	N/A

Remark: "N/A" denotes no model name, serial no. or calibration specified.

All calibration period of equipment list is one year.

3.1.3 TEST PROCEDURE

- a. The EUT was placed 0.8 meters from the horizontal ground plane with EUT being connected to the power mains through a line impedance stabilization network (LISN). All other support equipment powered from additional LISN(s). The LISN provide 50 Ohm/ 50uH of coupling impedance for the measuring instrument.
- b. Interconnecting cables that hang closer than 40 cm to the ground plane shall be folded back and forth in the center forming a bundle 30 to 40 cm long.
- c. I/O cables that are not connected to a peripheral shall be bundled in the center. The end of the cable may be terminated, if required, using the correct terminating impedance. The overall length shall not exceed 1 m.
- d. LISN at least 80 cm from nearest part of EUT chassis.
- e. For the actual test configuration, please refer to the related Item –EUT Test Photos.
- f. Measuring frequency range from 150KHz to 30MHz.

3.1.4 DEVIATION FROM TEST STANDARD

No deviation

3.1.5 TEST SETUP

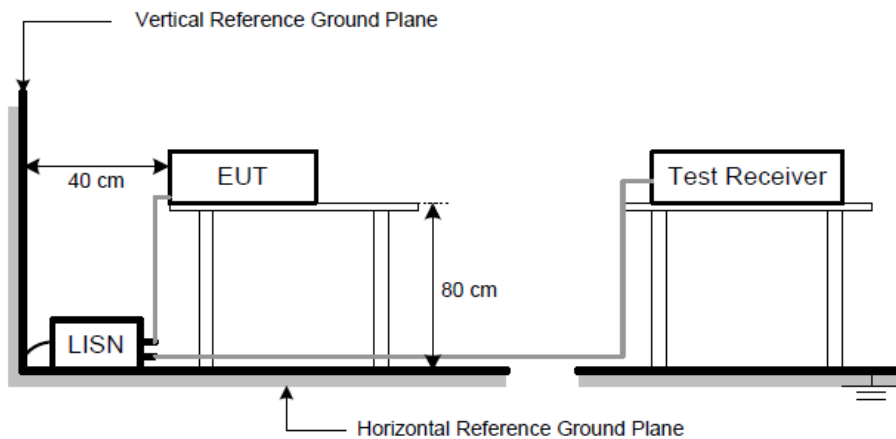

3.1.6 TEST RESULTS

Remark

- (1) Reading in which marked as QP means measurements by using are Quasi-Peak Mode with Detector BW=9 kHz; SPA setting in RBW=10 kHz, VBW =10 kHz, Swp. Time = 0.3 sec./MHz. Reading in which marked as AV means measurements by using are Average Mode with instrument setting in RBW=10 kHz, VBW=10 kHz, Swp. Time =0.3 sec./MHz.
- (2) All readings are QP Mode value unless otherwise stated AVG in column of [Note] . If the QP Mode Measured value compliance with the QP Limits and lower than AVG Limits, the EUT shall be deemed to meet both QP & AVG Limits and then only QP Mode was measured, but AVG Mode didn't perform. In this case, a " * " marked in AVG Mode column of Interference Voltage Measured.

Test Voltage	AC 120V/60Hz	Phase	Line
Test Mode	Mode 1		

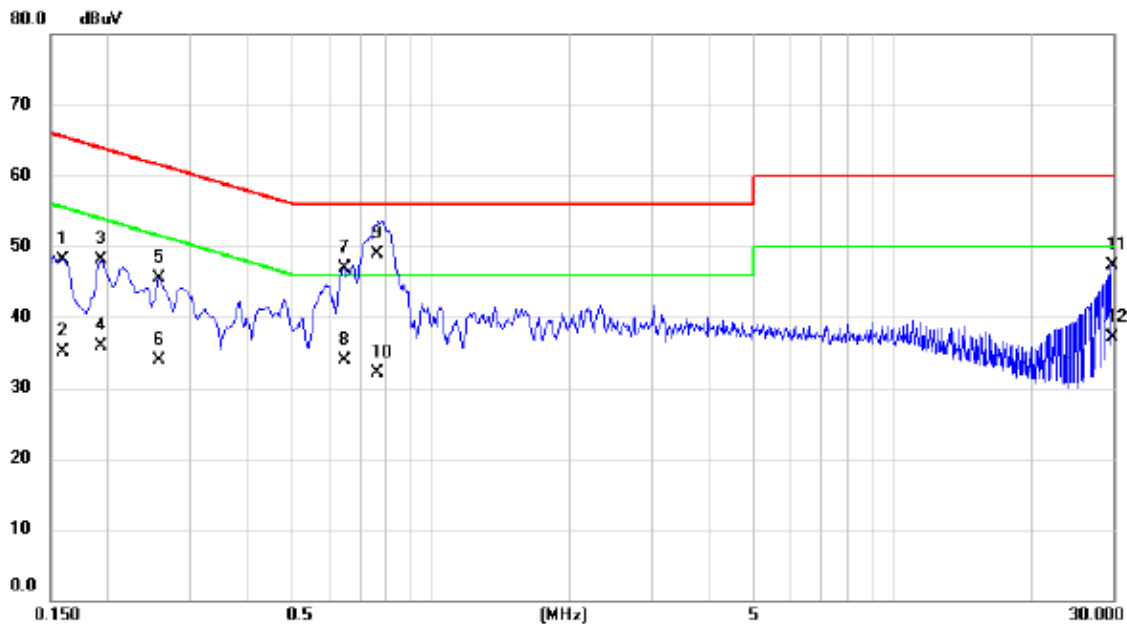

No.	Mk.	Freq.	Reading	Correct	Measure-	Limit	Margin		
		MHz	dBuV	Factor	ment	dBuV	dB	Detector	Comment
1		0.1590	38.51	9.59	48.10	65.52	-17.42	QP	
2		0.1590	25.60	9.59	35.19	55.52	-20.33	AVG	
3		0.1928	38.47	9.59	48.06	63.92	-15.86	QP	
4		0.1928	26.30	9.59	35.89	53.92	-18.03	AVG	
5		0.2580	35.88	9.59	45.47	61.50	-16.03	QP	
6		0.2580	24.40	9.59	33.99	51.50	-17.51	AVG	
7		0.6495	37.28	9.62	46.90	56.00	-9.10	QP	
8		0.6495	24.30	9.62	33.92	46.00	-12.08	AVG	
9	*	0.7665	39.20	9.65	48.85	56.00	-7.15	QP	
10		0.7665	22.50	9.65	32.15	46.00	-13.85	AVG	
11		29.9985	36.11	11.25	47.36	60.00	-12.64	QP	
12		29.9985	25.80	11.25	37.05	50.00	-12.95	AVG	

Test Voltage	AC 120V/60Hz	Phase	Neutral
Test Mode	Mode 1		

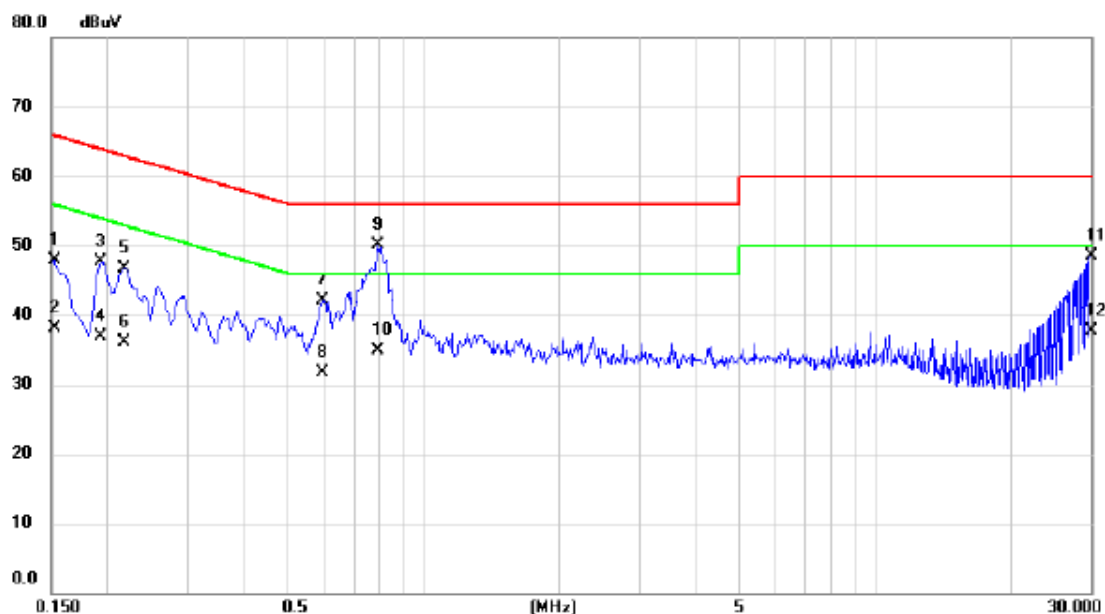

No.	Mk.	Freq. MHz	Reading Level dBuV	Correct Factor dB	Measure- ment dBuV	Limit dBuV	Margin dB	Detector	Comment
1		0.1522	38.34	9.57	47.91	65.88	-17.97	QP	
2		0.1522	28.60	9.57	38.17	55.88	-17.71	AVG	
3		0.1928	38.20	9.57	47.77	63.92	-16.15	QP	
4		0.1928	27.30	9.57	36.87	53.92	-17.05	AVG	
5		0.2175	37.13	9.57	46.70	62.91	-16.21	QP	
6		0.2175	26.60	9.57	36.17	52.91	-16.74	AVG	
7		0.5977	32.44	9.61	42.05	56.00	-13.95	QP	
8		0.5977	22.10	9.61	31.71	46.00	-14.29	AVG	
9	*	0.7912	40.47	9.63	50.10	56.00	-5.90	QP	
10		0.7912	25.30	9.63	34.93	46.00	-11.07	AVG	
11		30.0000	37.09	11.37	48.46	60.00	-11.54	QP	
12		30.0000	26.30	11.37	37.67	50.00	-12.33	AVG	

3.2 RADIATED EMISSIONS

3.2.1 LIMITS

Operating frequency	Field Strength (uV/m)	Measurement Distance (meters)	F.S Limitation at 3m Distance
			(dBuV/m)
Any non-ISM	15	300	103.5

NOTE:

- (1) The Equipment is for 18.305(b) Any type unless otherwise specified (miscellaneous) Operating frequency in any non-ISM frequency
- (2) Operation of ISM equipment within the following safety, search and rescue frequency bands is prohibited: 490–510 kHz, 2170–2194 kHz, 8354–8374 kHz, 121.4–121.6 MHz, 156.7–156.9 MHz, and 242.8–243.2 MHz.
- (3) Distance extrapolation factor = $40 \log(\text{specific distance} / \text{test distance})$ (dB);
Limit line = specific limits (dBuV) + distance extrapolation factor.
- (4) The test result calculated as following:
Measurement Value = Reading Level + Correct Factor
Correct Factor = Antenna Factor + Cable Loss - Amplifier Gain(if use)
Margin Level = Measurement Value - Limit Value

3.2.2 MEASUREMENT INSTRUMENTS LIST

Item	Kind of Equipment	Manufacturer	Type No.	Serial No.	Calibrated until
1	Antenna	ETS	3142B	00026419	Apr. 17, 2021
2	Amplifier	SONOMA	310N	186128	Feb. 28, 2021
3	EMI Test Receiver	R&S	ESCI	100895	Feb. 28, 2021
4	Cable	emci	LMR-400(30MHz-1 GHz)(7m+7m)	N/A	Sep. 28, 2020
5	Controller	ETS-Lindgren	2090	N/A	N/A
6	Measurement Software	Farad	EZ-EMC Ver.NB-03A1-01	N/A	N/A

Remark: "N/A" denotes no model name, serial no. or calibration specified.

All calibration period of equipment list is one year.

3.2.3 TEST PROCEDURE

- a. The EUT was placed on the top of a rotating table 0.8 meters above the ground at a 3 meter semi-anechoic chamber. The table was rotated 360 degrees to determine the position of the highest radiation.
- b. The height of the equipment or of the substitution antenna shall be 0.8 m; the height of the test antenna shall be 1 m.
- c. The initial step in collecting radiated emission data is a spectrum analyzer peak detector mode pre-scanning the measurement frequency range. Significant peaks are then marked and then Quasi Peak detector mode re-measured.
- d. If the Peak Mode measured value compliance with and lower than Quasi Peak Mode Limit, the EUT shall be deemed to meet QP Limits and then no additional QP Mode measurement performed.
- e. For the actual test configuration, please refer to the related Item –EUT Test Photos.

3.2.4 DEVIATION FROM TEST STANDARD

No deviation

3.2.5 TEST SETUP

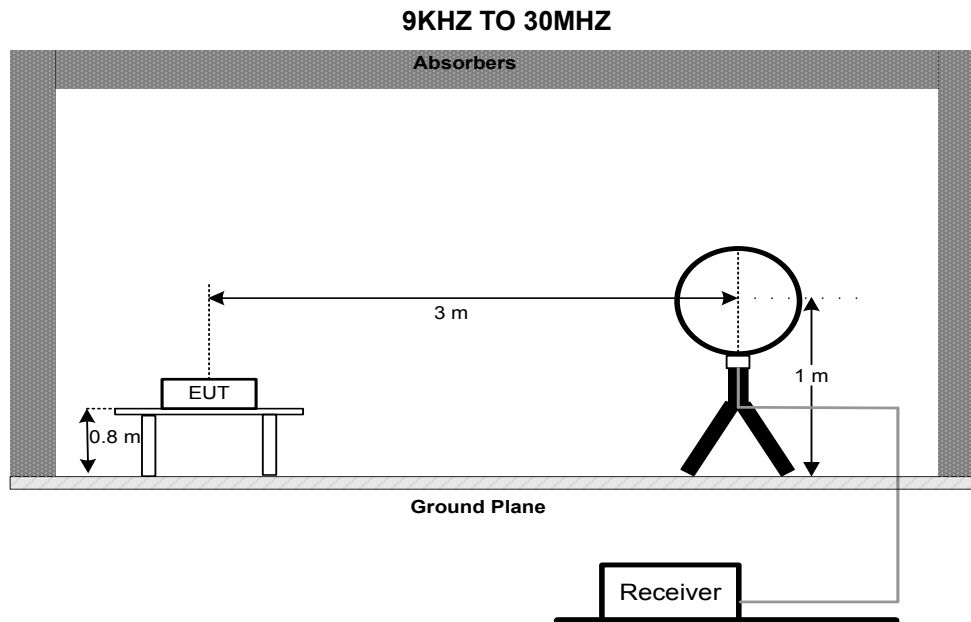

3.2.6 TEST RESULTS-9 KHZ to 30 MHZ

Remark:

- (1) All readings are Peak unless otherwise stated QP in column of 『Note』 . Peak denotes that the Peak reading compliance with the QP Limits and then QP Mode measurement didn't perform.
- (2) Measuring frequency range from 9kHz to 30MHz
- (3) If the peak scan value lower limit more than 20dB, then this signal data does not show in table.

Test Voltage:	AC 120V/60Hz
Test Mode:	Mode 1

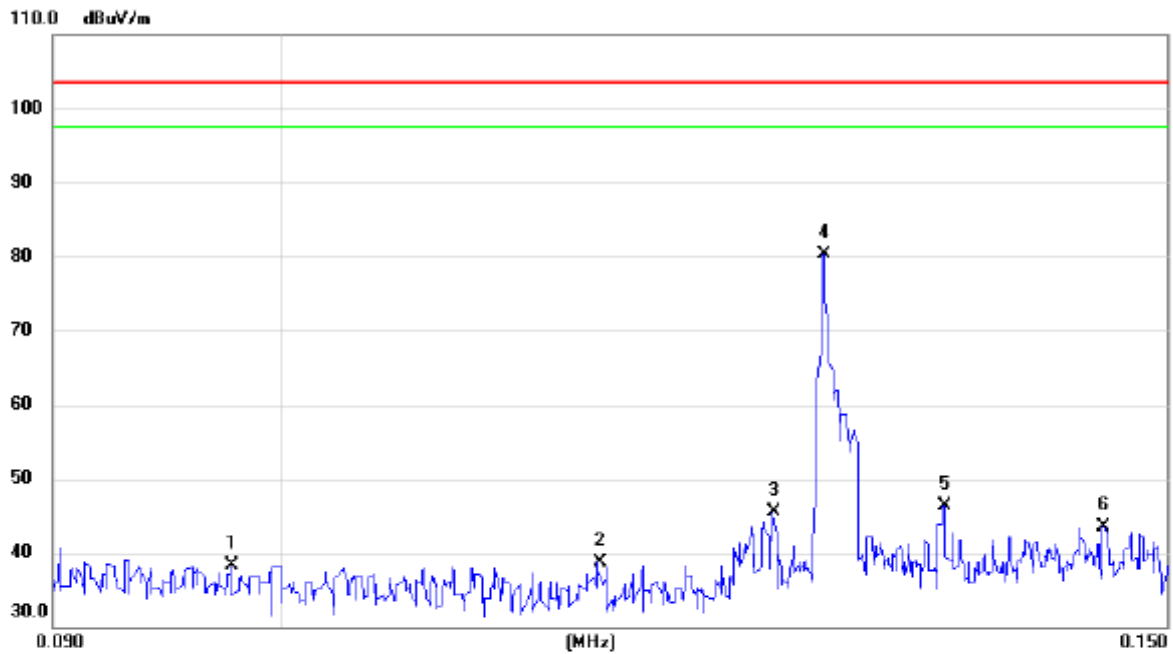

No.	Mk.	Freq. MHz	Reading Level dBuV	Correct Factor dB	Measure- ment dBuV/m	Limit dBuV/m	Margin dB	Detector	Comment
1		0.0977	25.74	12.63	38.37	103.50	-65.13	QP	
2		0.1157	26.10	12.65	38.75	103.50	-64.75	QP	
3		0.1253	32.80	12.65	45.45	103.50	-58.05	QP	
4	*	0.1282	67.62	12.65	80.27	103.50	-23.23	QP	
5		0.1355	33.69	12.65	46.34	103.50	-57.16	QP	
6		0.1457	30.93	12.66	43.59	103.50	-59.91	QP	

Test Voltage:	AC 120V/60Hz
Test Mode:	Mode 1

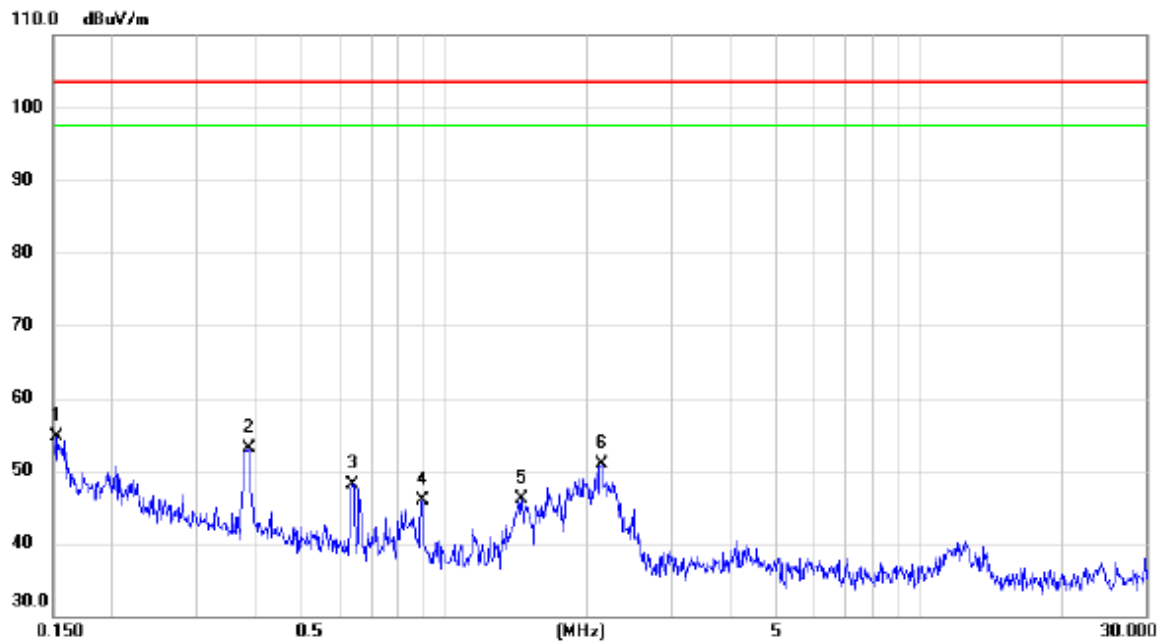

No.	Mk.	Freq. MHz	Reading Level dBuV	Correct Factor dB	Measure- ment dBuV/m	Limit dBuV/m	Margin dB	Detector	Comment
1	*	0.1532	41.97	12.66	54.63	103.50	-48.87	QP	
2		0.3871	41.07	12.10	53.17	103.50	-50.33	QP	
3		0.6404	36.43	11.71	48.14	103.50	-55.36	QP	
4		0.8991	34.19	11.63	45.82	103.50	-57.68	QP	
5		1.4561	34.79	11.34	46.13	103.50	-57.37	QP	
6		2.1440	40.05	10.93	50.98	103.50	-52.52	QP	

4. EUT TEST PHOTO

AC Power Line Conducted Emissions

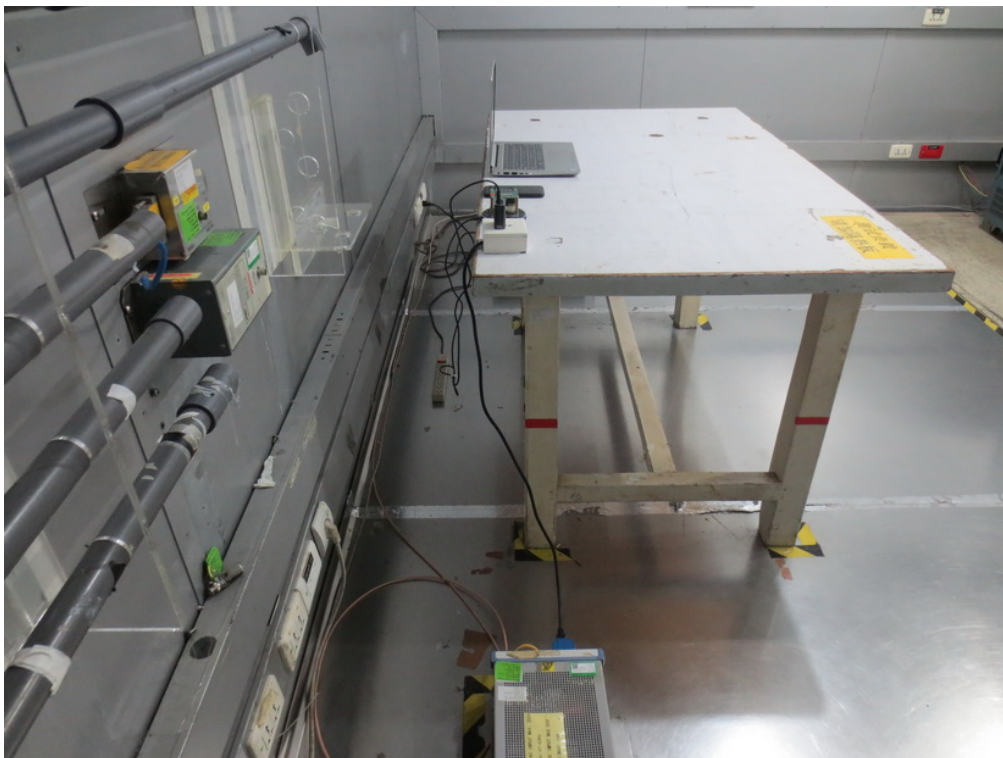

Radiated Emissions 9kHz to 30MHz

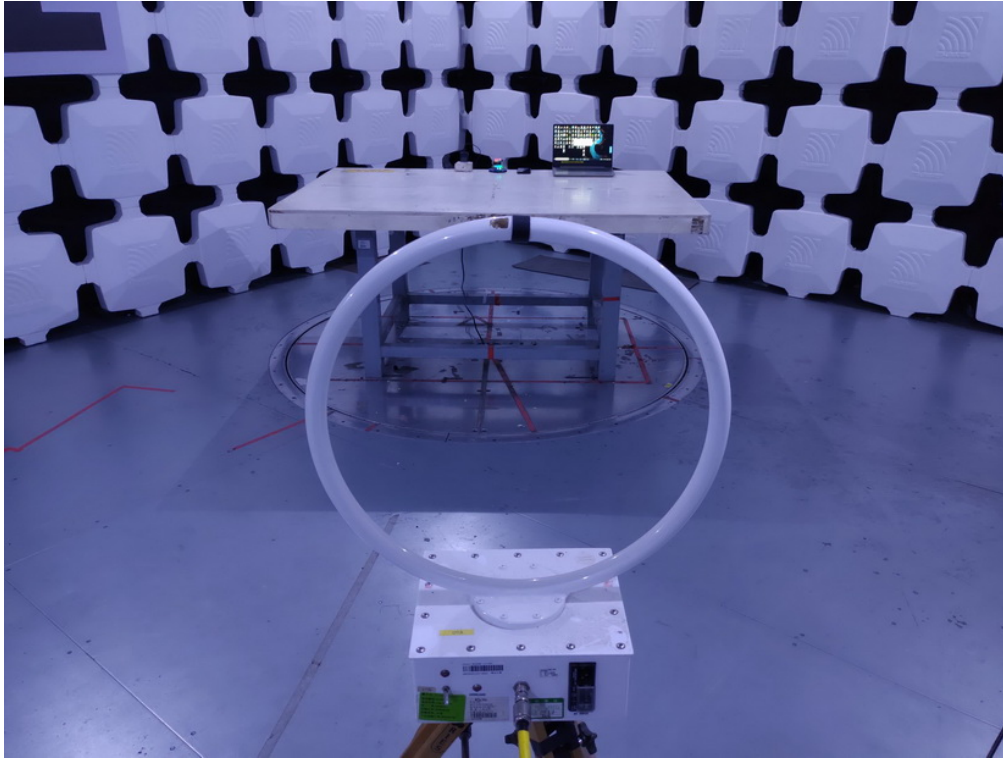

End of Test Report