

TEST REPORT

For

Bluetooth Module (BTLE)

In conformity with

FCC CFR 47 Part15 Subpart C

Model : SP14808

FCC ID : 2ACNB14808

Report No. : ERY1501P16R1

Issue Date : 16 Jan. 2015

Prepared for

TDK Corporation
Shibaura Renasite Tower, 3-9-1 Shibaura, Minato-ku, Tokyo
108-0023, Japan

Prepared by

SGS RF Technologies Inc.
472, Nippa-cho, Kohoku-ku, Yokohama, 223-0057, Japan
Telephone: +81+(0)45- 534-0645
FAX: +81+(0)45- 534-0646

This document is issued by the Company subject to its General Conditions of Service printed overleaf, available on request or accessible at www.sgs.com/terms_and_conditions.htm and, for electronic format documents, subject to Terms and Conditions for Electronic Documents at www.sgs.com/terms_e-document.htm. Attention is drawn to the limitation of liability, indemnification and jurisdiction issues defined therein. Any holder of this document is advised that information contained hereon reflects the Company's findings at the time of its intervention only and within the limits of Client's instructions, if any. The Company's sole responsibility is to its Client and this document does not exonerate parties to a transaction from exercising all their rights and obligations under the transaction documents. This document cannot be reproduced except in full, without prior written approval of the Company. Any unauthorized alteration, forgery or falsification of the content or appearance of this document is unlawful and offenders may be prosecuted to the fullest extent of the law.

SGS RF Technologies Inc. is managed to ISO17025 and has the necessary knowledge and test facilities for testing according to the referenced standards. The test results in this report apply only to the sample(s) tested.

Table of contents

1	General information.....	4
1.1	Product description	4
1.2	Test(s) performed/ Summary of test result	4
1.3	Test facility	5
1.4	Measurement uncertainty.....	5
1.5	Summary of test results.....	6
1.6	Setup of equipment under test (EUT).....	6
1.6.1	Test configuration of EUT.....	6
1.6.2	Operating condition:	6
1.6.3	Setup diagram of tested system.....	7
1.7	Equipment modifications.....	7
1.8	Deviation from the standard	7
2	Test procedure and test data	8
2.1	Occupied Bandwidth (99%).....	8
2.2	6dB Bandwidth	10
2.3	Peak Output Power	12
2.4	Conducted Spurious Emissions.....	14
2.5	Power Spectral density.....	18
2.6	Radiated emissions	20
2.7	AC power line conducted emissions.....	27
3	Test setup photographs	30
3.1	Radiated emissions	30
3.2	AC power line conducted emissions.....	30
4	List of utilized test equipment / calibration	31

History

Report No.	Date	Revisions	Issued By
ERY1501P16R1	16 Jan. 2015	Initial Issue	T.Kato

1 General information

1.1 Product description

Test item : Bluetooth Module (BTLE)
Manufacturer : TDK Corporation Kofu Plant
Address : 160 Miyazawa, Minami Alps City, Yamanashi Prefecture,400-0495,
Japan
Model : SP14808
FCC ID : 2ACNB14808
Serial number : 47, 55
Software version : 1.0
Hardware version : 1.0
Operating frequency : 2402 - 2480 MHz
Modulation : GFSK
Receipt date of EUT : 08 Jan. 2015
Nominal power source voltages : 3.0 Vdc nominal (Operating range: 2.35 - 3.3 Vdc)

1.2 Test(s) performed/ Summary of test result

Test specification(s) : FCC CFR 47 Part 15 Subpart C (01 Oct. 2013)
Test method(s) : ANSI C63.4: 2003
KDB Publication No. 558074
Test(s) started : 08 Jan. 2015
Test(s) completed : 15 Jan. 2015
Purpose of test(s) : Certification
Summary of test result : Complied

Note: The above judgment is only based on the measurement data and it does not include the measurement uncertainty. Accordingly, the statement below is applied to the test result.
The EUT complies with the limit required in the standard in case that the margin is not less than the measurement uncertainty in the Laboratory.
Compliance of the EUT is more probable than non-compliance is case that the margin is less than the measurement uncertainty in the Laboratory.

Test engineer

: 
T. Kato
EMC testing Department

Reviewer

: 
K. Onishi
Manager
EMC testing Department

1.3 Test facility

The Federal Communications Commission has reviewed the technical characteristics of the test facilities at SGS RF Technologies Inc., located in 472, Nippa-cho, Kohoku-ku, Yokohama, 223-0057, Japan, and has found these test facilities to be in compliance with the requirements of 47 CFR Part 15, section 2.948, per October 1, 2013.

The description of the test facilities has been filed under registration number 319924 at the Office of the Federal Communications Commission. The facility has been added to the list of laboratories performing these test services for the public on a fee basis.

The list of all public test facilities is available on the Internet at <http://www.fcc.gov>.

Registered by Industry Canada (IC): The registered facility number is as follows;
Test site No. 1 (Semi-Anechoic chamber 3m): 6974A-1

Accredited by **National Voluntary Laboratory Accreditation Program (NVLAP)** for the emission tests stated in the scope of the certificate under Certificate Number 200780-0

This report must not be used by the client to claim product certification, approval, or endorsement by NVLAP, NIST, or any agency of the Federal Government.



NVLAP LAB CODE 200780-0

1.4 Measurement uncertainty

The treatment of uncertainty is based on the general matters on the definition of uncertainty in “Guide to the expression of uncertainty in measurement (GUM)” published by ISO. The Lab’s uncertainty is determined by referring UKAS Publication LAB34: 2002 “The Expression of Uncertainty in EMC Testing” and CISPR16-4-2: 2011 “Uncertainty in EMC Measurements”.

The uncertainty of the measurement result in the level of confidence of approximately 95% (k=2) is as follows;

Conducted emission: ± 3.4 dB (10 kHz - 30 MHz)
Radiated emission (9 kHz - 30 MHz): ± 3.3 dB
Radiated emission (30 MHz - 200 MHz): ± 5.0 dB
Radiated emission (200 MHz - 1000 MHz): ± 6.2 dB
Radiated emission (1 GHz - 6 GHz): ± 4.7 dB
Radiated emission (6 GHz - 18 GHz): ± 4.8 dB
Radiated emission (18 GHz - 26 GHz): ± 5.0 dB

1.5 Summary of test results

Requirement	Section in specification	Result	Section in this report
Occupied Bandwidth (99 %)	2.1049	Complied	2.1
6 dB Bandwidth	15.247 (a) (2)	Complied	2.2
Conducted Output Power	15.247 (b) (3)	Complied	2.3
Conducted Spurious Emission	15.247 (d)	Complied	2.4
Power Spectral Density	15.247 (e)	Complied	2.5
Radiated Emissions	15.247(d), 15.205 (a)	Complied	2.6
AC power line conducted emissions	15.207	Complied	2.7

1.6 Setup of equipment under test (EUT)

1.6.1 Test configuration of EUT

Equipment(s) under test

No.	Item	Manufacture	Model No.	Serial No.
A1	Bluetooth Module (for Conducted test)	TDK Corporation	SP14808	55
A2	Bluetooth Module (for Radiated test)	TDK Corporation	SP14808	47

Support Equipment(s)

No.	Item	Manufacture	Model No.	Serial No.
B	Connection Board	-	-	-
C	AAA size battery	-	-	-
D	AC adaptor (Output: DC 3.3V)	UNIFIVE	US303320	D02-0136115

Connected cable(s)

No.	Item	Identification (Manu.etc.)	Cable Shielded	Ferrite Core	Length [m]
1	DC cable for battery	-	No	No	0.15
2	DC cable for AC adaptor	-	No	No	1.0

1.6.2 Operating condition:

- Tx (2402MHz): The EUT is in normal transmission mode in 2402 MHz.
- Tx (2440MHz): The EUT is in normal transmission mode in 2440 MHz.
- Tx (2480MHz): The EUT is in normal transmission mode in 2480 MHz.

1.6.3 Setup diagram of tested system

[Configuration A]

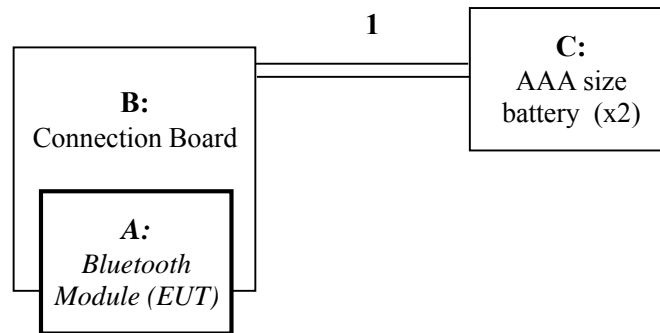

[Configuration B]

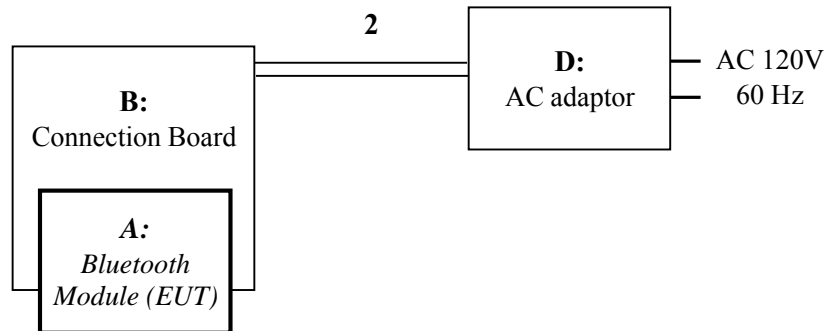

1.7 Equipment modifications

No modifications have been made to the equipment in order to achieve compliance with the applicable standards described in clause 1.2.

1.8 Deviation from the standard

No deviations from the standards described in clause 1.2.

2 Test procedure and test data

2.1 Occupied Bandwidth (99%)

Test setup

Test setup is the following drawing. The antenna port of EUT was connected to the spectrum analyzer.

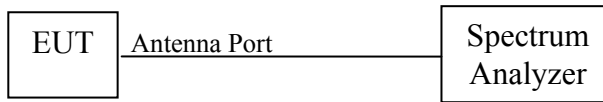

Test procedure

Spectrum analyzer is set as below according to ANSI C63.4: 2003 clause 13.1.7.

- RBW = 100 kHz
- VBW > 3 x RBW
- Detector : Peak

Limitation

There are no limitations.
 The measurement value is used for the emission designator.

Test equipment used (refer to List of utilized test equipment)

TR06	CL31				
------	------	--	--	--	--

Test results

Configuration: A
 Tested sample: A1

Transmission Frequency [MHz]	Occupied Bandwidth [MHz]
2402	1.081
2440	1.086
2480	1.086

[Chart]

Tx (2440 MHz)

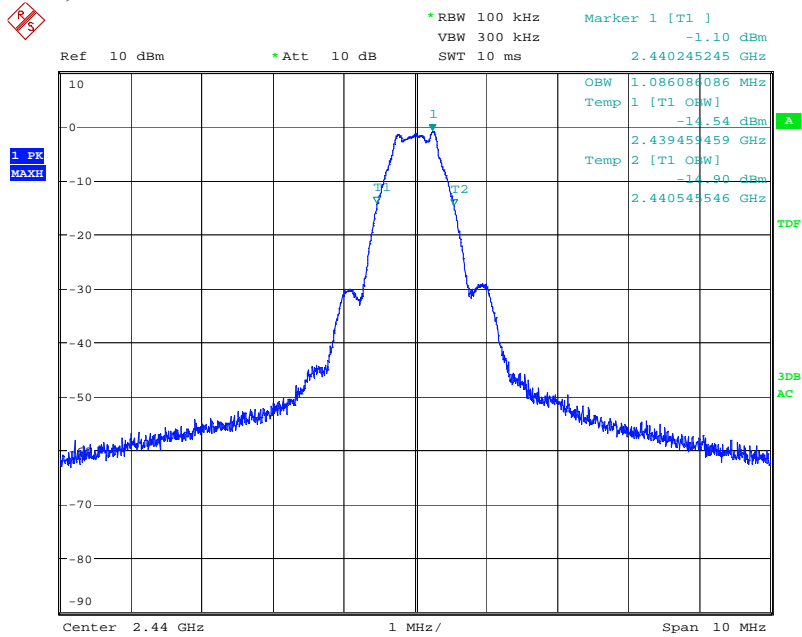

Tested Date: 08 Jan. 2015
 Humidity: 35 %

Temperature: 16 degC
 Atmos. Press: 1010 hPa

2.2 6dB Bandwidth

Test setup

Test setup is the following drawing. The antenna port of EUT was connected to the spectrum analyzer.

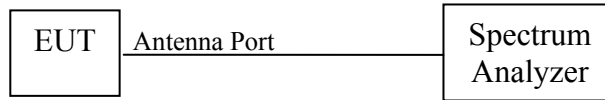

Test procedure

Spectrum analyzer is set as below according to KDB 558074 clause 8.1

- RBW = 100 kHz
- VBW > 3 x RBW
- Detector : Peak

Applicable rule and limitation

15.247 (a) (2) Systems using digital modulation techniques may operate in the 902–928 MHz, 2400–2483.5 MHz, and 5725–5850 MHz bands. The minimum 6 dB bandwidth shall be at least 500 kHz.

Test equipment used (refer to List of utilized test equipment)

TR06	CL31				
------	------	--	--	--	--

Test results - Complied with requirement

Test Data

Configuration: A

Tested sample: A1

Transmission Frequency [MHz]	6 dB Bandwidth [kHz]
2402	731
2440	736
2480	736

[Chart]

Tx 2440 MHz

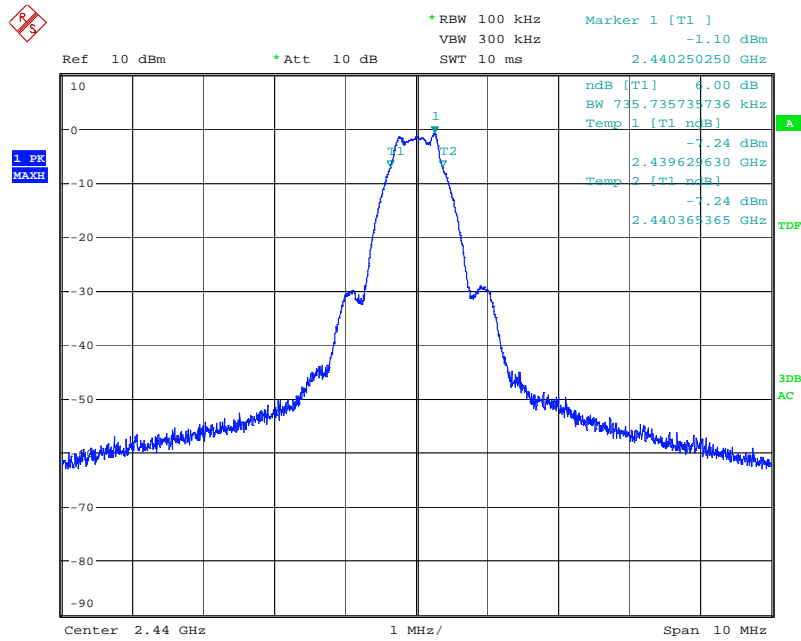

Tested Date: 08 Jan. 2015
 Humidity: 35 %

Temperature: 16 degC
 Atmos. Press: 1010 hPa

2.3 Peak Output Power

Test setup

Test setup is the following drawing. The antenna port of EUT was connected to the spectrum analyzer.

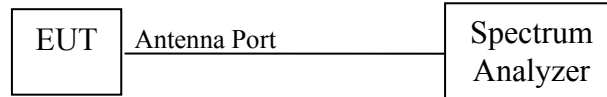

Test procedure

Spectrum analyzer is set as below according to KDB 558074 clause 9.1.1

- Span > 3 x RBW
- RBW > 6dB BW
- VBW > 3 x RBW
- Detector : Peak

Applicable rule and limitation

15.247(b) (3) For systems using digital modulation in the 902–928 MHz, 2400–2483.5MHz, and 5725–5850 MHz bands: 1 Watt (30 dBm).

Test equipment used (refer to List of utilized test equipment)

TR06	CL31				
------	------	--	--	--	--

Test results - Complied with requirement

Test Data

Configuration: A

Tested sample: A1

Transmission Frequency [MHz]	Output Power [dBm]
2402	-0.32
2440	-0.42
2480	-0.57

[Chart]

Tx 2440 MHz

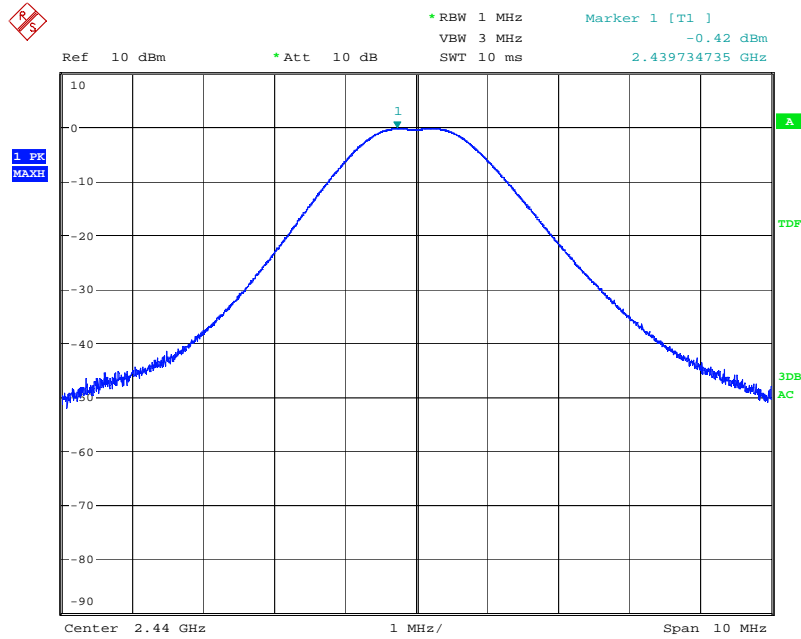

Tested Date: 08 Jan. 2015
 Humidity: 35 %

Temperature: 16 degC
 Atmos. Press: 1010 hPa

2.4 Conducted Spurious Emissions (for non-restricted frequency band)

Test setup

Test setup is the following drawing. The antenna port of EUT was connected to the spectrum analyzer.

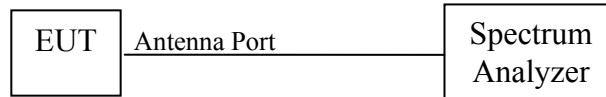

Test procedure

Spectrum analyzer is set as below according to KDB 558074 clause 11.2 and 11.3

- Span > 1.5 x [6dB BW]
- RBW = 100 kHz
- VBW > 300 kHz
- Detector : Peak

Limitation

15.247(d) In any 100 kHz bandwidth outside the frequency band in which the spread spectrum or digitally modulated intentional radiator is operating, the radio frequency power that is produced by the intentional radiator shall be at least 20 dB below that in the 100 kHz bandwidth within the band that contains the highest level of the desired power, based on either an RF conducted or a radiated measurement, provided the transmitter demonstrates compliance with the peak conducted power limits.

Test equipment used (refer to List of utilized test equipment)

TR06	CL31				
------	------	--	--	--	--

Test results - Complied with requirement

Test Data

Configuration: A
 Tested sample: A1

Operating mode: Tx (2402 MHz)

Frequency [MHz]	Spurious level [dBm]	Carrier level [dBm]	20dB below [dBm]
88.006	-60.48	-1.42	-21.42
4803.600	-48.63	-1.42	-21.42
7205.300	-52.50	-1.42	-21.42

Operating mode: Tx (2440 MHz)

Frequency [MHz]	Spurious level [dBm]	Carrier level [dBm]	20dB below [dBm]
126.030	-61.12	-1.32	-21.32
4880.600	-48.72	-1.32	-21.32
7319.200	-51.60	-1.32	-21.32

Operating mode: Tx (2480 MHz)

Frequency [MHz]	Spurious level [dBm]	Carrier level [dBm]	20dB below [dBm]
166.043	-62.83	-1.18	-21.18
4959.600	-48.31	-1.18	-21.18
7439.300	-51.95	-1.18	-21.18

[Chart]

Tx 2440 MHz

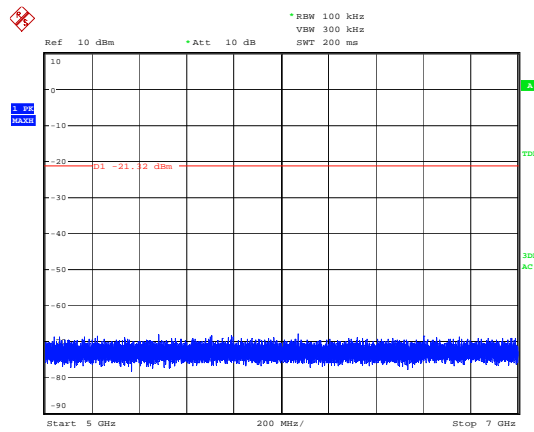
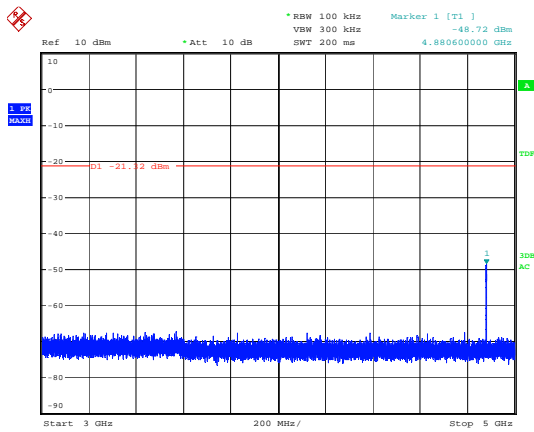
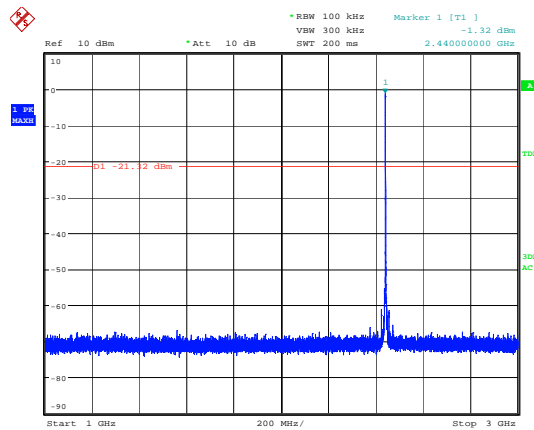
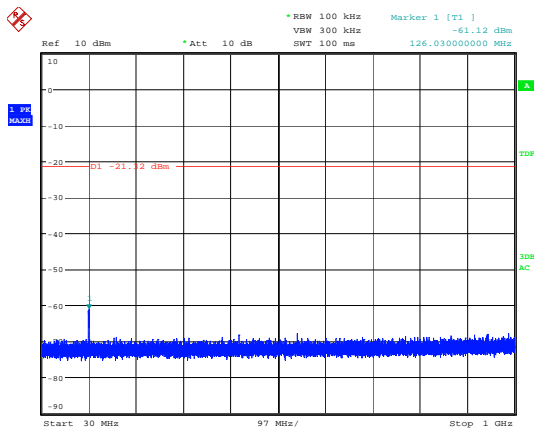

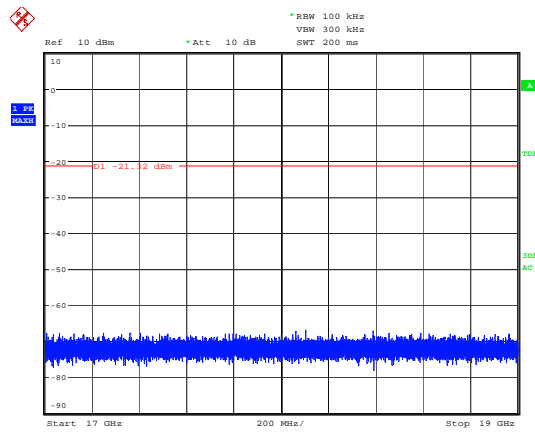
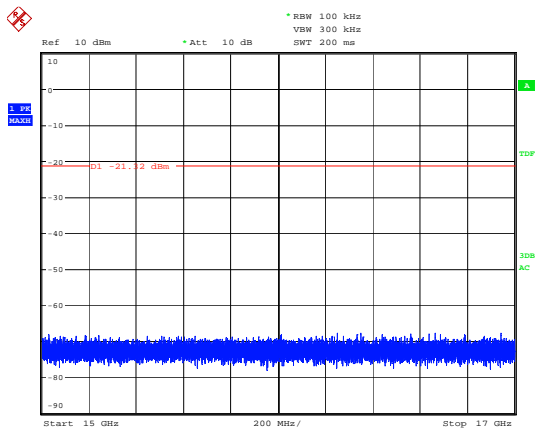
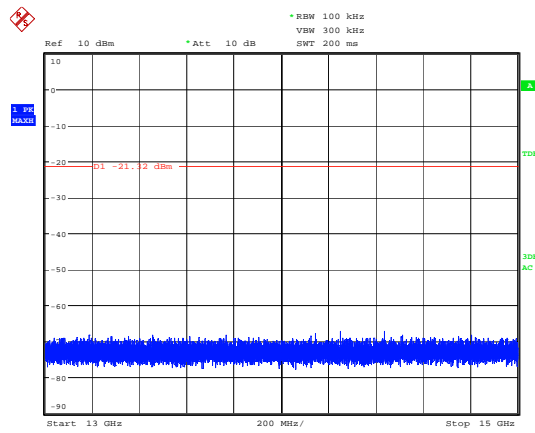
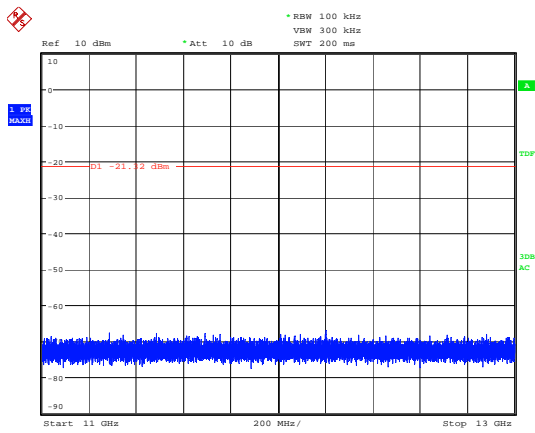
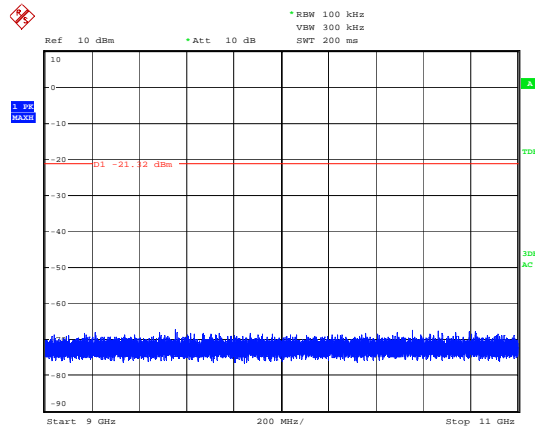
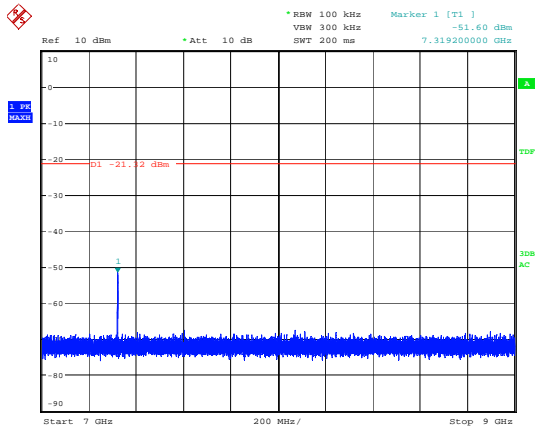

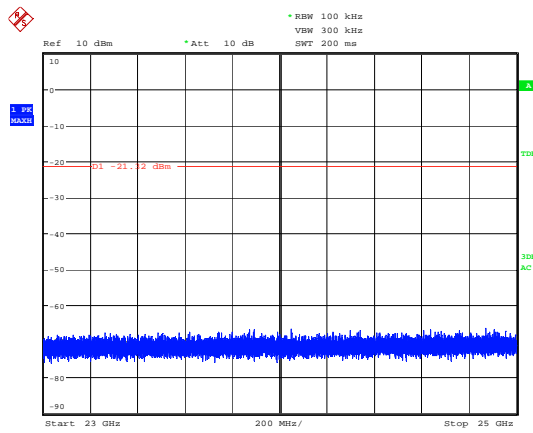
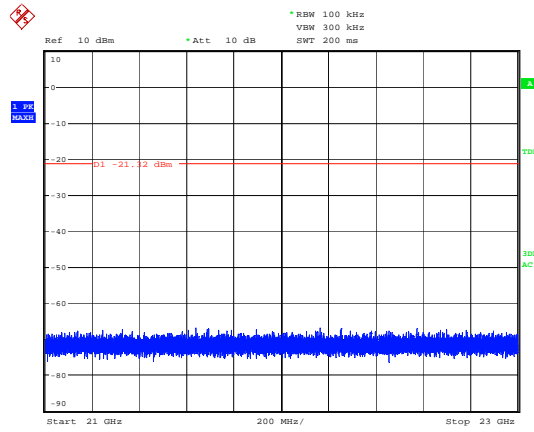
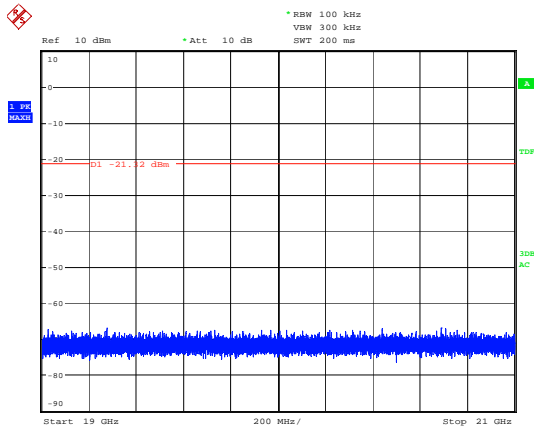

Tested Date: 08 Jan. 2015
 Humidity: 35 %

Temperature: 16 degC
 Atmos. Press: 1010 hPa

2.5 Power Spectral density

Test setup

Test setup is the following drawing. The antenna port of EUT was connected to the spectrum analyzer.

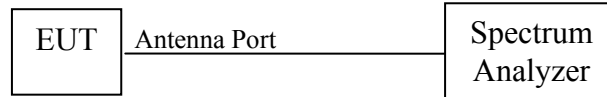

Test procedure

Spectrum analyzer is set as below according to KDB 558074 clause 10.2

- Span > 1.5 x [6dB BW]
- RBW = 3 kHz
- VBW > 3 x RBW
- Detector : Peak

Limitation

15.247(e) For digitally modulated systems, the power spectral density conducted from the intentional radiator to the antenna shall not be greater than 8 dBm in any 3 kHz band during any time interval of continuous transmission.

Test equipment used (refer to List of utilized test equipment)

TR06	CL31				
------	------	--	--	--	--

Test results - Complied with requirement

Test Data

Configuration: A
 Tested sample: A1

Transmission Frequency [MHz]	Spectral Density [dBm]
2402	-16.68
2440	-16.69
2480	-16.77

[Chart]

Tx 2440 MHz

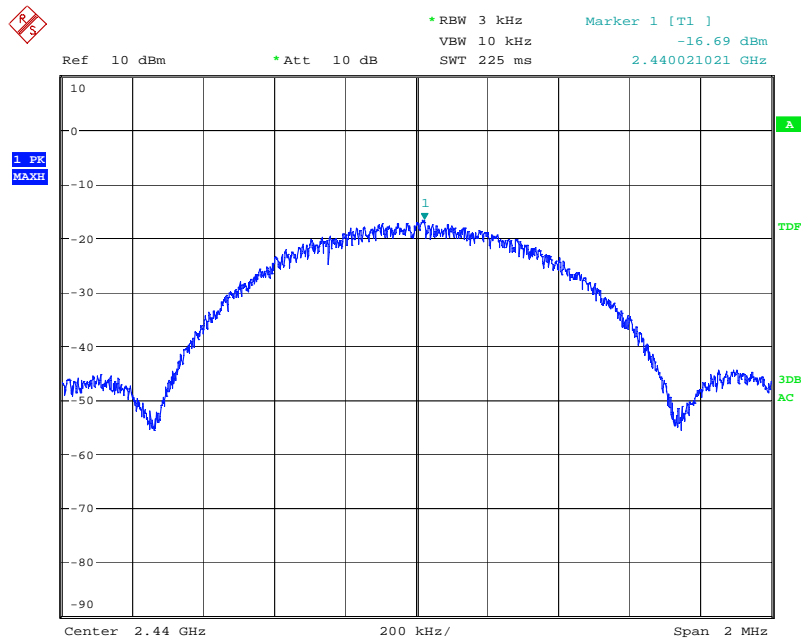

Tested Date: 08 Jan. 2015
 Humidity: 35 %

Temperature: 16 degC
 Atmos. Press: 1010 hPa

2.6 Radiated emissions (for restricted frequency band)

Test setup

Test setup was implemented according to the method of ANSI C63.4: 2003 clause 6 “General requirements for EUT equipment arrangements and operation”, clause 8.2 and Annex H.3 “Radiated emission measurements setup”.

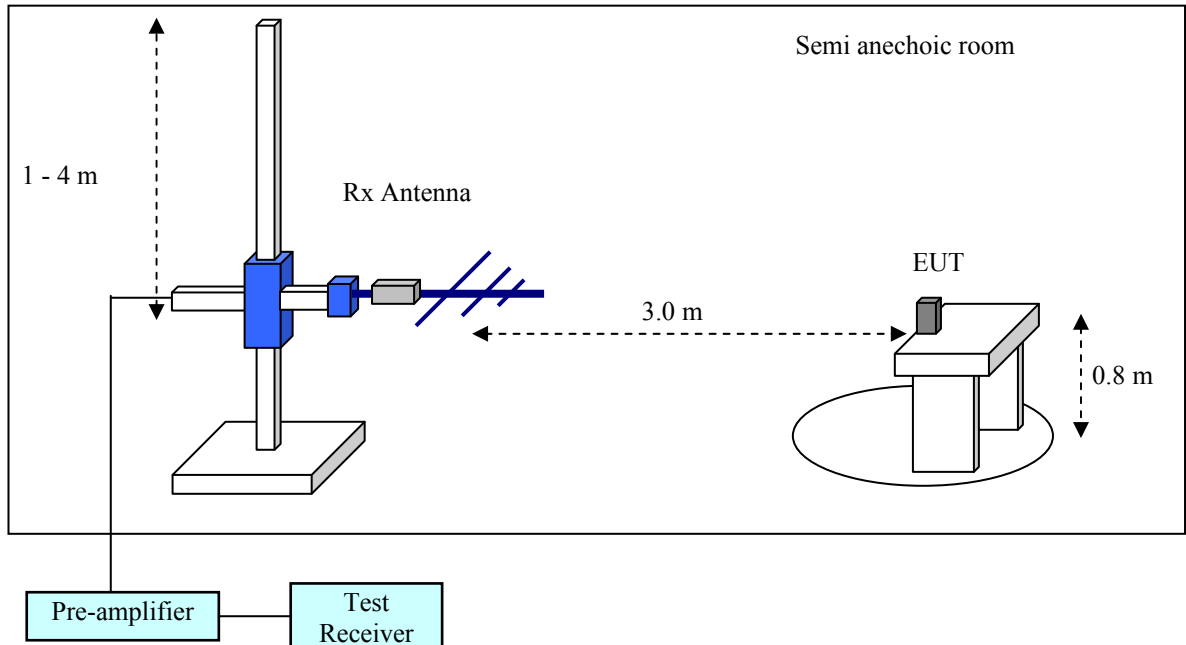

Test procedure

Measurement procedures were implemented according to the method of ANSI C63.4: 2003 clauses 8.3. The test receiver is set as below

[below 1000 MHz]
 RBW: 120 kHz, Detector: QP

[above 1000 MHz]
 RBW: 1 MHz, Detector: Ave/PK

Applicable rule and limitation

FCC 15.205 restricted bands of operation

Except as shown in paragraph 15.205 (d) of this section, only spurious emissions are permitted in any of the frequency bands listed below:

MHz	MHz	MHz	GHz
0.090 - 0.110	16.42 - 16.423	399.9 - 410	4.5 - 5.15
0.490 - 0.510	16.69475 - 16.69525	608 - 614	5.35 - 5.46
2.1735 - 2.1905	16.80425 - 16.80475	960 - 1240	7.25 - 7.75
4.125 - 4.128	25.5 - 25.67	1300 - 1427	8.025 - 8.5
4.17725 - 4.17775	37.5 - 38.25	1435 - 1626.5	9.0 - 9.2
4.20725 - 4.20775	73 - 74.6	1645.5 - 1646.5	9.3 - 9.5
6.215 - 6.218	74.8 - 75.2	1660 - 1710	10.6 - 12.7
6.26775 - 6.26825	108 - 121.94	1718.8 - 1722.2	13.25 - 13.4
6.31175 - 6.31225	123 - 138	2200 - 2300	14.47 - 14.5
8.291 - 8.294	149.9 - 150.05	2310 - 2390	15.35 - 16.2
8.362 - 8.366	156.52475 - 156.52525	2483.5 - 2500	17.7 - 21.4
8.37625 - 8.38675	156.7 - 156.9	2690 - 2900	22.01 - 23.12
8.41425 - 8.41475	162.0125 - 167.17	3260 - 3267	23.6 - 24.0
12.29 - 12.293	167.72 - 173.2	3332 - 3339	31.2 - 31.8
12.51975 - 12.52025	240 - 285	3345.8 - 3358	36.43 - 36.5
12.57675 - 12.57725	322 - 335.4	3600 - 4400	38.6 -

The field strength of emissions appearing within these frequency bands shall not exceed the limits shown in FCC 15.209. At frequencies equal to or less than 1000 MHz, compliance with the limits in FCC 15.209 shall be demonstrated using measurement instrumentation employing a CISPR quasi-peak detector. Above 1000 MHz, compliance with the emission limits in Section 15.209 shall be demonstrated based on the average value of the measured emissions.

FCC 15.209 Field strength limits

Frequency [MHz]	Field Strength [μ V/m]	Measurement Distance [m]	Field Strength [dB μ V/m]
30 – 88	100	3	40.0
88 – 216	150	3	43.5
216 – 960	200	3	46.0
Above 960	500	3	53.9

In the emission table above, the tighter limit applies at the band edges.

The emission limits shown in the above table are based on measurements employing a quasi-peak detector.

Test results - Complied with requirement

Test equipment used (refer to List of utilized test equipment)

AC01	CL11	TR06	PR15	BA10	CL29	CL30
PR12	DH01	CH01	SH01			

Test software used

EMI Ver. 5.6

Calculation method

The Correction Factor and Result are calculated as followings.

$$\text{Correction Factor [dB/m]} = \text{Ant. Factor [dB/m]} + \text{Loss [dB]} - \text{Gain [dB]}$$

$$\text{Result [dB}\mu\text{V/m]} = \text{Reading [dB}\mu\text{V]} + \text{Correction Factor [dB/m]}$$

Test Data

Configuration: A

Tested sample: A2

Operating mode: Tx (2402 MHz)

[Emission level] X-plane

No.	Frequency [MHz]	Reading PK [dB μ V]	Reading Ave [dB μ V]	C.Factor [dB]	Result PK [dB μ V/m]	Result Ave [dB μ V/m]	Limit PK [dB μ V/m]	Limit Ave [dB μ V/m]	Ant.
1	2390.000	44.1	30.7	-4.5	39.6	26.2	73.9	53.9	Hori.
2	4804.000	43.0	31.6	2.4	45.4	34.0	73.9	53.9	Hori.

Note: All other emissions are below the noise floor.

[Emission level] Y-plane

No.	Frequency [MHz]	Reading PK [dB μ V]	Reading Ave [dB μ V]	C.Factor [dB]	Result PK [dB μ V/m]	Result Ave [dB μ V/m]	Limit PK [dB μ V/m]	Limit Ave [dB μ V/m]	Ant.
1	2385.942	45.0	32.4	-4.5	40.5	27.9	73.9	53.9	Hori.

Note: All other emissions are below the noise floor.

[Emission level] Z-plane

No.	Frequency [MHz]	Reading PK [dB μ V]	Reading Ave [dB μ V]	C.Factor [dB]	Result PK [dB μ V/m]	Result Ave [dB μ V/m]	Limit PK [dB μ V/m]	Limit Ave [dB μ V/m]	Ant.
1	2386.001	45.0	32.0	-4.5	40.5	27.5	73.9	53.9	Vert.

Note: All other emissions are below the noise floor.

Configuration: A
 Tested sample: A2
 Operating mode: Tx (2440 MHz)

[Emission level] X-plane

No.	Frequency [MHz]	Reading PK [dB μ V]	Reading Ave [dB μ V]	C.Factor [dB]	Result PK [dB μ V/m]	Result Ave [dB μ V/m]	Limit PK [dB μ V/m]	Limit Ave [dB μ V/m]	Ant.
1	4880.000	44.2	33.1	2.5	46.7	35.6	73.9	53.9	Hori.
2	7320.000	44.1	32.2	8.5	52.6	40.7	73.9	53.9	Hori.
3	4880.000	43.4	31.9	2.5	45.9	34.4	73.9	53.9	Vert.
4	7320.000	44.1	31.7	8.5	52.6	40.2	73.9	53.9	Vert.

Note: All other emissions are below the noise floor.

[Emission level] Y-plane

No.	Frequency [MHz]	Reading PK [dB μ V]	Reading Ave [dB μ V]	C.Factor [dB]	Result PK [dB μ V/m]	Result Ave [dB μ V/m]	Limit PK [dB μ V/m]	Limit Ave [dB μ V/m]	Ant.
1	4880.000	44.6	34.5	2.5	47.1	37.0	73.9	53.9	Hori.
2	7320.000	44.6	34.5	8.5	53.1	43.0	73.9	53.9	Hori.
3	4880.000	44.1	32.4	2.5	46.6	34.9	73.9	53.9	Vert.
4	7320.000	43.9	32.8	8.5	52.4	41.3	73.9	53.9	Vert.

Note: All other emissions are below the noise floor.

[Emission level] Z-plane

No.	Frequency [MHz]	Reading PK [dB μ V]	Reading Ave [dB μ V]	C.Factor [dB]	Result PK [dB μ V/m]	Result Ave [dB μ V/m]	Limit PK [dB μ V/m]	Limit Ave [dB μ V/m]	Ant.
1	4880.000	44.4	33.1	2.5	46.9	35.6	73.9	53.9	Hori.
2	7320.000	43.9	32.8	8.5	52.4	41.3	73.9	53.9	Hori.
3	4880.000	43.6	32.3	2.5	46.1	34.8	73.9	53.9	Vert.
4	7320.000	42.7	30.1	8.5	51.2	38.6	73.9	53.9	Vert.

Note: All other emissions are below the noise floor.

Configuration: A
 Tested sample: A2
 Operating mode: Tx (2480 MHz)

[Emission level] X-plane

No.	Frequency [MHz]	Reading PK [dB μ V]	Reading Ave [dB μ V]	C.Factor [dB]	Result PK [dB μ V/m]	Result Ave [dB μ V/m]	Limit PK [dB μ V/m]	Limit Ave [dB μ V/m]	Ant.
1	2483.500	52.0	38.9	-3.7	48.3	35.2	73.9	53.9	Hori.
2	4960.000	43.3	32.2	2.8	46.1	35.0	73.9	53.9	Hori.
3	7440.000	42.8	30.7	8.0	50.8	38.7	73.9	53.9	Hori.
4	4960.000	43.5	33.0	2.8	46.3	35.8	73.9	53.9	Vert.
5	7440.000	43.2	30.4	8.0	51.2	38.4	73.9	53.9	Vert.

Note: All other emissions are below the noise floor.

[Emission level] Y-plane

No.	Frequency [MHz]	Reading PK [dB μ V]	Reading Ave [dB μ V]	C.Factor [dB]	Result PK [dB μ V/m]	Result Ave [dB μ V/m]	Limit PK [dB μ V/m]	Limit Ave [dB μ V/m]	Ant.
1	2483.500	51.9	38.7	-3.7	48.2	35.0	73.9	53.9	Hori.
2	4960.000	43.6	34.8	2.8	46.4	37.6	73.9	53.9	Hori.
3	7440.000	43.3	32.1	8.0	51.3	40.1	73.9	53.9	Hori.
4	4960.000	43.0	31.5	2.8	45.8	34.3	73.9	53.9	Vert.
5	7440.000	44.2	32.7	8.0	52.2	40.7	73.9	53.9	Vert.
6	12400.000	42.0	28.0	4.4	46.4	32.4	73.9	53.9	Vert.

Note: All other emissions are below the noise floor.

[Emission level] Z-plane

No.	Frequency [MHz]	Reading PK [dB μ V]	Reading Ave [dB μ V]	C.Factor [dB]	Result PK [dB μ V/m]	Result Ave [dB μ V/m]	Limit PK [dB μ V/m]	Limit Ave [dB μ V/m]	Ant.
1	2483.500	49.5	35.8	-3.7	45.8	32.1	73.9	53.9	Hori.
2	4960.000	42.6	30.9	2.8	45.4	33.7	73.9	53.9	Hori.
3	7440.000	42.5	29.3	8.0	50.5	37.3	73.9	53.9	Hori.
4	2483.500	50.4	36.5	-3.7	46.7	32.8	73.9	53.9	Vert.
5	4960.000	43.0	31.7	2.8	45.8	34.5	73.9	53.9	Vert.
6	7440.000	44.9	33.1	8.0	52.9	41.1	73.9	53.9	Vert.
7	12400.000	41.9	28.4	4.4	46.3	32.8	73.9	53.9	Vert.

Note: All other emissions are below the noise floor.

[Chart : band-edge]

Tx 2480 MHz (Y-plane)

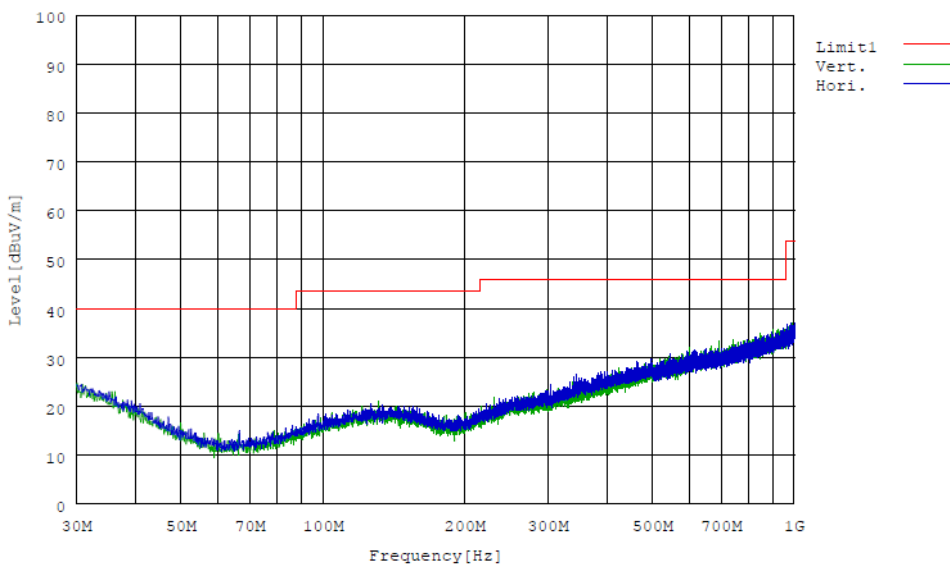

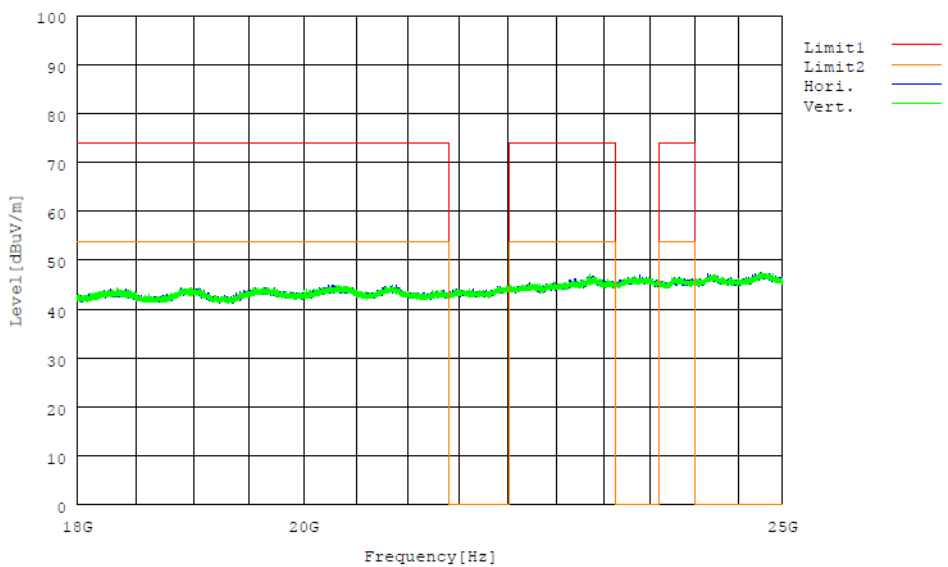
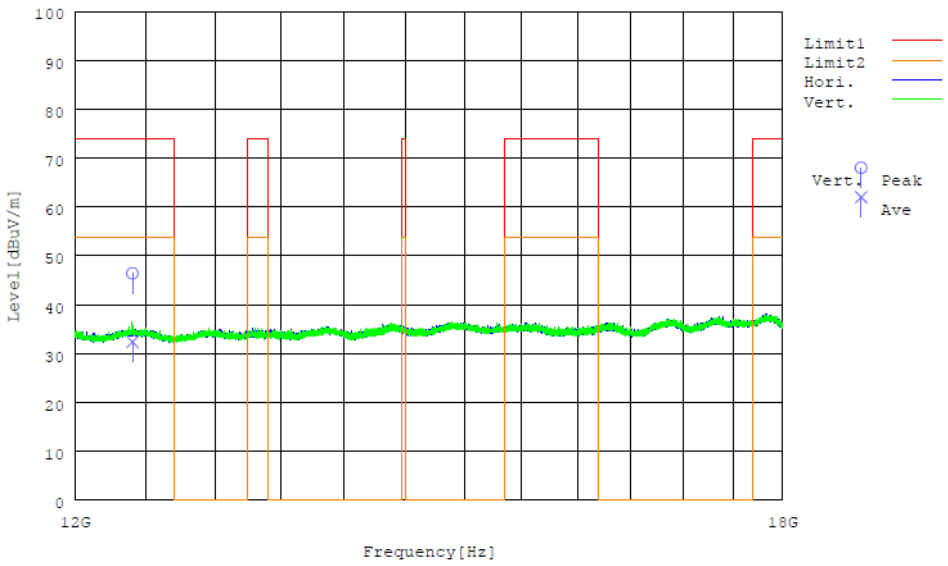
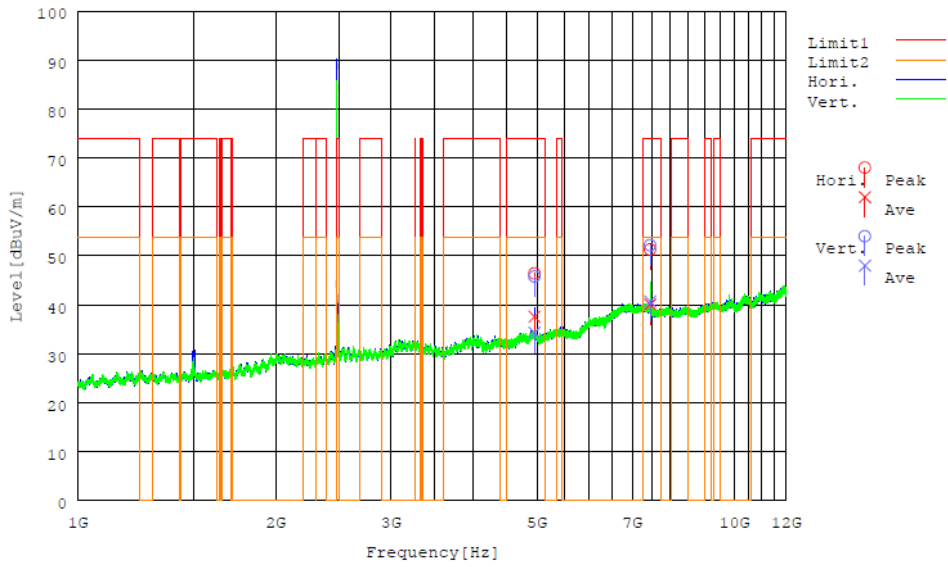

[Chart : band-edge]

Tx 2402 MHz (Y-plane)

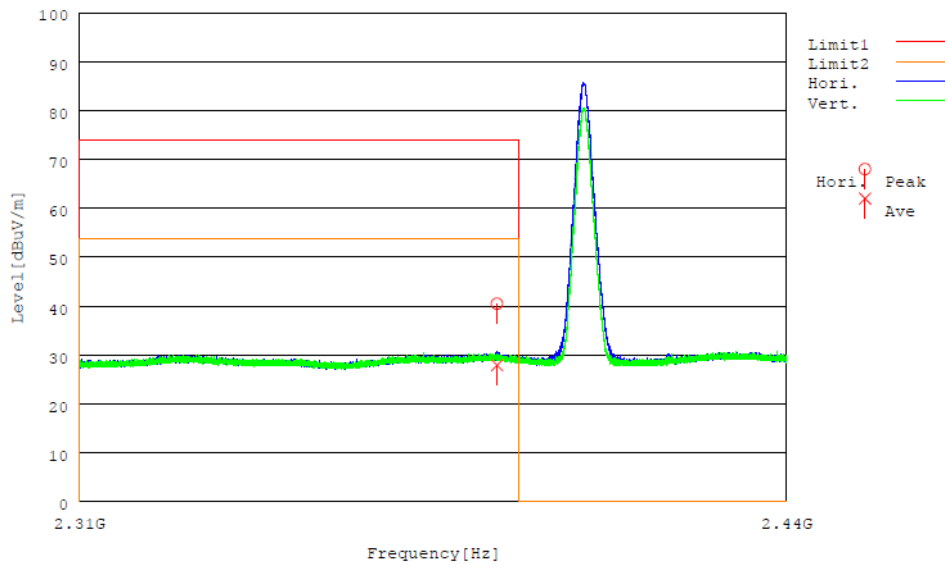

Tx 2480 MHz (Y-plane)

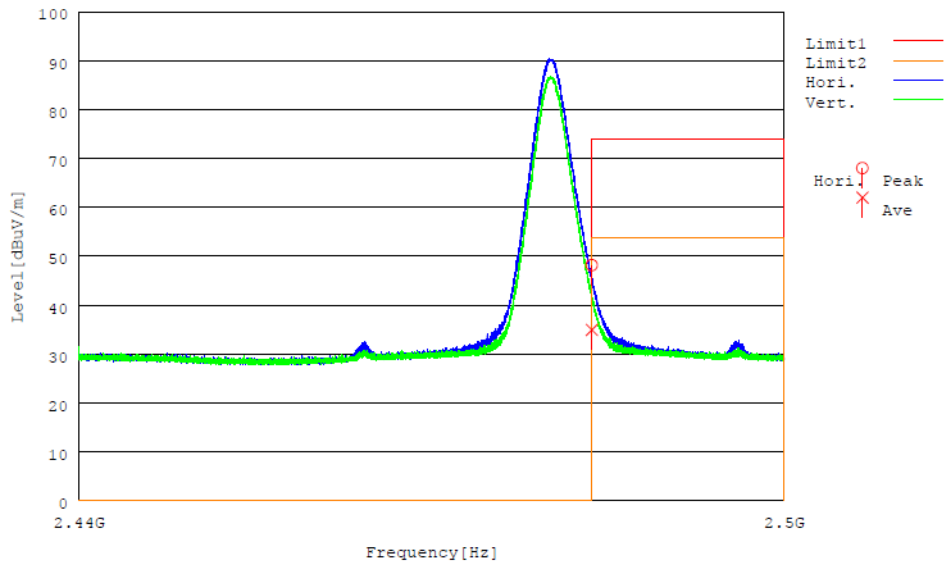

Tested Date: 15 Jan. 2015
 Humidity: 36 %

Temperature: 15 degC
 Atmos. Press: 1019 hPa

2.7 AC power line conducted emissions

Test setup

Test setup was implemented according to the method of ANSI C63.4: 2003 clause 6 “General requirements for EUT equipment arrangements and operation” and Annex H.1 “AC power line conducted emission measurements setup”.

Test procedure

Measurement procedures were implemented according to the method of ANSI C63.4: 2003 clauses 7, clause 13.1.3 and Annex H.2 “AC power line conducted emission measurements”.

Applicable rule and limitation

FCC 15.207 AC power line conducted emissions limits

Frequency of Emission [MHz]	Conducted emissions Limit [dB μ V]	
	Quasi-peak	Average
0.15 - 0.5	66 to 56 *	56 to 46 *
0.5 - 5	56	46
5 - 30	60	50

* Decreases with the logarithm of the frequency. The lower limit applies at the band edges.

Test equipment used (refer to List of utilized test equipment)

TR06	CL18	LN05
------	------	------

Test software used

EMI Ver. 5.6

Calculation method

The Correction Factor and Result are calculated as followings.

$$\begin{aligned} \text{Correction Factor [dB]} &= \text{ISN Factor [dB]} + \text{Loss [dB]} \\ \text{Result [dB}\mu\text{V]} &= \text{Reading [dB}\mu\text{V]} + \text{Correction Factor [dB]} \end{aligned}$$

Test results - Complied with requirement

Test Data

Configuration: B
 Tested sample: A1
 Operating mode: Tx (2402 MHz)

[Emission level]

No.	Frequency [MHz]	Reading		C.F. [dB]	Result		Limit		Phase	Pass/Fail
		QP [dBμV]	AV [dBμV]		QP [dBμV]	AV [dBμV]	QP [dBμV]	AV [dBμV]		
1	0.15000	27.3	6.7	10.3	37.6	17.0	66.0	56.0	Va	Pass
2	0.16813	24.7	5.6	10.3	35.0	15.9	65.1	55.1	Va	Pass
3	0.17959	23.6	7.1	10.3	33.9	17.4	64.5	54.5	Va	Pass
4	0.21770	20.6	6.8	10.2	30.8	17.0	62.9	52.9	Va	Pass
5	0.15000	26.9	6.2	10.3	37.2	16.5	66.0	56.0	Vb	Pass
6	0.23804	19.4	3.1	10.2	29.6	13.3	62.2	52.2	Vb	Pass

Configuration: B
 Tested sample: A1
 Operating mode: Tx (2440 MHz)

[Emission level]

No.	Frequency [MHz]	Reading		C.F. [dB]	Result		Limit		Phase	Pass/Fail
		QP [dBμV]	AV [dBμV]		QP [dBμV]	AV [dBμV]	QP [dBμV]	AV [dBμV]		
1	0.15000	27.2	6.5	10.3	37.5	16.8	66.0	56.0	Va	Pass
2	0.19550	22.2	6.1	10.3	32.5	16.4	63.8	53.8	Va	Pass
3	0.34384	11.3	5.0	10.2	21.5	15.2	59.1	49.1	Va	Pass
4	0.15000	26.7	6.1	10.3	37.0	16.4	66.0	56.0	Vb	Pass
5	0.19883	21.8	4.0	10.2	32.1	14.3	63.7	53.7	Vb	Pass
6	0.35753	8.7	0.4	10.2	18.9	10.6	58.8	48.8	Vb	Pass

Configuration: B
 Tested sample: A1
 Operating mode: Tx (2480 MHz)

[Emission level]

No.	Frequency [MHz]	Reading		C.F. [dB]	Result		Limit		Phase	Pass/Fail
		QP [dBμV]	AV [dBμV]		QP [dBμV]	AV [dBμV]	QP [dBμV]	AV [dBμV]		
1	0.15000	27.0	6.4	10.3	37.3	16.7	66.0	56.0	Va	Pass
2	0.17368	23.8	5.2	10.3	34.1	15.5	64.8	54.8	Va	Pass
3	0.15000	26.7	6.0	10.3	37.0	16.3	66.0	56.0	Vb	Pass
4	0.23878	19.1	2.9	10.2	29.3	13.1	62.1	52.1	Vb	Pass
5	0.30833	13.3	1.1	10.2	23.5	11.3	60.0	50.0	Vb	Pass
6	0.44409	10.5	3.3	10.2	20.7	13.5	57.0	47.0	Vb	Pass

[Chart]

Operating mode: Tx (2440 MHz)

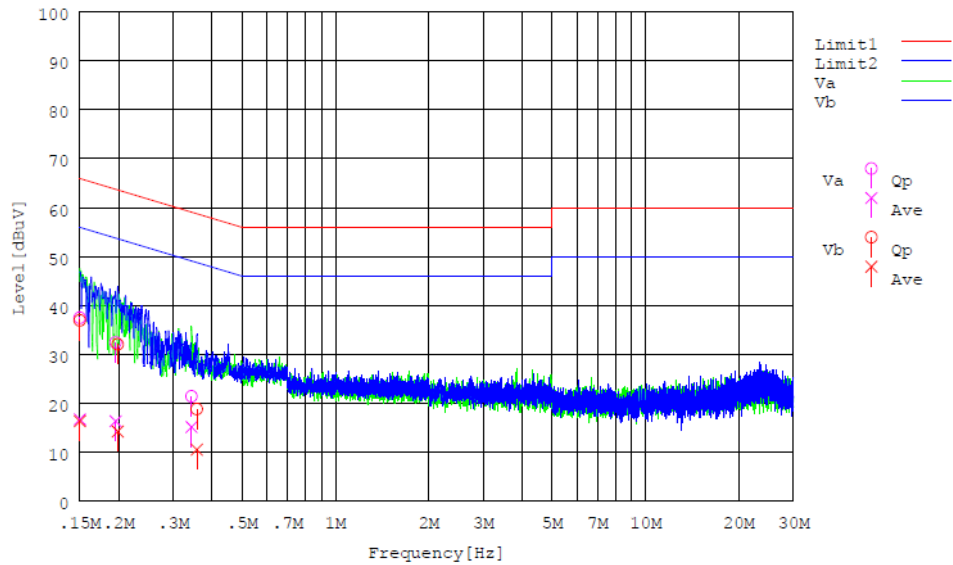

Tested Date: 08 Jan. 2015
 Humidity: 35 %

Temperature: 16 degC
 Atmos. Press: 1010 hPa

4 List of utilized test equipment / calibration

RFT ID No.	Kind of Equipment and Precision	Manufacturer	Model No.	Serial Number	Calibration Date	Calibrated until
AC01(EM)	Anechoic Chamber (1st test room)	JSE	203397C	-	2014/4/26	2015/4/30
AC01(EG)	Anechoic Chamber (1st test room)	JSE	203397C	-	2014/11/24	2015/11/30
BA10	Biological Antenna	TESEQ	CBL6111D	32342	2014/6/9	2015/6/30
CH01	Conical Horn Antenna (12-18GHz)	ETS-Lindgren	3163-05	00126641	2014/7/3	2016/7/31
CL11	Antenna Cable for RE	RFT	-	-	2014/3/31	2015/3/31
CL18	Antenna Cable for CE	RFT	-	-	2014/4/18	2015/4/30
CL29	RF Cable 2 m	SUHNER	SUCOFLEX104PE	94709	2014/1/21	2015/1/31
CL31	RF Cable 1 m	Junkosha	MWX221	1303S118	2014/10/6	2015/10/31
DH01	DRG Horn Antenna	A.H. Systems	SAS-571	785	2014/1/21	2016/1/31
LN05	LISN	Kyoritsu	KNW-407F	8-1773-2	2014/5/22	2015/5/31
PR12	Pre. Amplifier (1-26G)	Agilent Technologies	8449B	3008A02513	2014/1/21	2015/1/31
PR15	Pre. Amplifier	Anritsu	MH648A	6201156141	2014/6/10	2015/6/30
SH01	Standard Horn Antenna (18-26G)	A.H. Systems	SAS-572	208	2014/7/3	2016/7/31
TR06	Test Receiver (E/W : 3.93 SP2)	Rohde & Schwarz	ESU26	100002	2014/9/5	2015/9/30

The measuring equipment, which was utilized in performing the tests documented herein, has been calibrated in accordance with the manufacturer's recommendations for utilizing calibration equipment, which is traceable to recognized national standards.