

# Bike Speed&Cadence sensor

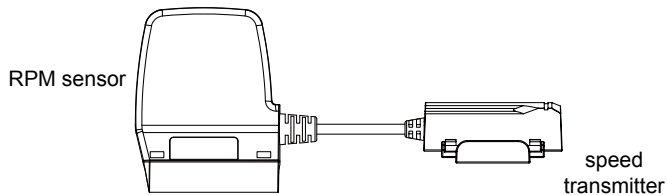

This Bike Speed&Cadence Sensor consists of a separate Cadence Sensor wired to a Speed+Distance Sensor that has a battery hatch and a bluetooth4.0 transmitter. The sensor includes two magnets to activate the sensors and cable ties for installation.

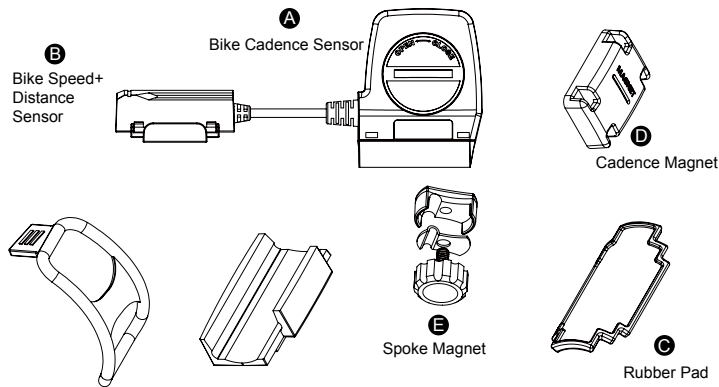

## INSTRUCTIONS

This Bike Speed&Cadence Sensor is mounted to the non-drive chainstay – the side of the bicycle opposite from the chain.

- Using two Cable Ties, loosely hang the Cadence Sensor (A) from the underside of the chainstay.
- With the bare side of the Cadence Magnet (D) placed against the backside of the crank arm, loosely attach the Cadence Magnet to the crank arm using a Cable Tie (F). -See picture.
- Align the magnet so the molded ridge between "CADENCE MAGNET" passes by the symbol "RPM" printed. Make sure the Cadence Magnet passed within 3/8" (10 mm) of the Cadence Sensor.

**NOTE:** Magnet placement on the crank arm may depend upon the Cadence Sensor placement, the bicycle type and/or the drive chain type.

- Tighten the Cable Tie for the Cadence Magnet, remove the adhesive covers on the Cadence Sensor, and tighten its Cable Ties.

**NOTE:** Bicycles with triple chainring cranksets and/or S-bend chainstays may require either the Cadence Magnet or the Cadence Sensor to be shimmed in order to get both pieces within correct proximity.

**CAUTION:** Be careful not to damage the covered wire between the connected sensors.

- Place the rubber pad (C) on the bottom of the Speed+Distance Sensor (B), and loosely attach it to the chain stay with the final two Cable Ties (A). Make sure the battery hatch faces away from the wheel for easy access.

- Remove the screw from the Spoke Magnet (E), place the part onto a rear wheel spoke so the bare magnet side passes within 3/8" (10 mm) of the center of the Speed+Distance Sensor.

**NOTE:** Location of the Speed+Distance Sensor on the chainstay may depend on Spoke Magnet placement, the bicycle type, and/or the drive chain type, or the position of the attached Cadence Sensor.

**NOTE:** Bicycles with triple chainring cranksets and/or S-bend chainstays may require the canting of the Speed+Distance Sensor toward the Spoke Magnet in order to get both pieces within correct proximity.

**CAUTION:** Be careful not to damage the covered wire between the connected sensors.

- Tighten the Cable Ties for the Speed+Distance Sensor, and trim the ends of all the cable ties with a scissor or diagonal cutter.

**NOTE:** Bicycles with triple chainring cranksets and/or S-bend chainstays may require the canting of the Speed+Distance Sensor toward the Spoke Magnet in order to get both pieces within correct proximity.

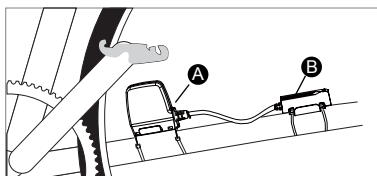
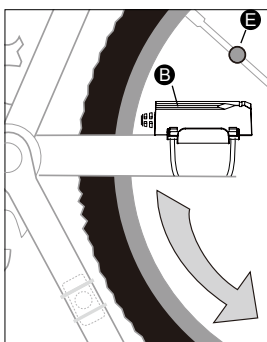
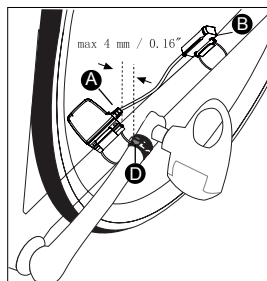

9. Refer to the APP instructions to pair and calibrate it with Bike Speed&Cadence Sensor and to display its data on the APP.

10. Periodically check the cable ties and spoke screw to make sure that they are secure.

## BATTERIES

The transmitter use 1pc CR2032 3V battery. The battery already installed. The battery typically last one year. We highly recommend that you contact the retailer or our customer service department if you need to replace them.

- Using a coin, twist the battery door counter clockwise until it clicks out of place.
- Remove the old battery and insert the new battery with the +side upwards.
- Replace the battery door by twisting it clockwise until it is firmly in place.

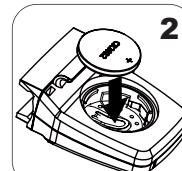

## IMPORTANT

- Non-rechargeable and rechargeable batteries must be disposed of properly. For this purpose, special containers are provided for non-rechargeable and rechargeable battery disposal at communal collection centers.
- Batteries are extremely dangerous when swallowed! Therefore, keep batteries and small articles away from children. If a battery has been swallowed seek immediate medical advice.
- The batteries supplied must not be recharged, reactivated by any other means, dismantled, put into fire or short-circuited.

## SUPPORTED DEVICE

- A. This device is a Bluetooth Smart and ANT+ device compatible with many smart Phones including:
- iPhone 4S and newer
  - New iPad and newer
  - iPad mini
  - iPod Touch5 and newer
  - GALAXY A3,A5,S4,S5,Note3,etc
  - Xperia E3,Z3,C3,T3,X8,5L.etc

B. In addition, this device is also recommended to work with the following APPS:

- Wahoofitness
- Strava
- MapMyRide

\* All brand names and trademarks are properties of their respective owners.

## TROUBLESHOOTING

Why my App cannot connect to the Speed&Cadence sensor?

- Please confirm the Bluetooth/ANT+ and the Speed & Cadence function in your App is open.
- If you are not using an APP, please confirm the App you using can support Bluetooth Smart/ANT+.
- The Bike Speed & Cadence Sensor Bluetooth/ANT+ sync function will be automatically shut down when there is no Bluetooth/ANT+ connection, please rotate the crank to turn on the sensor and launch the connection, the sensor will be on for 1min after benign waked up, if there is no connection from the App during the time, the sensor will go into sleep mode.
- Please confirm the distances from the sensor and your mobile phone is within 2 meters.
- Please check the battery installed in the sensor, exchange the battery if it is dead.

## FCC WARNING

This device complies with Part 15 of the FCC Rules. Operation is subject to the following two conditions:

- This device may not cause harmful interference, and
- this device must accept any interference received, including interference that may cause undesired operation.

**NOTE 1:** Any changes or modifications to this unit not expressly approved by the party responsible for compliance could void the user's authority to operate the equipment.