



■ **Report No.:** DDT-R16Q0105-5E1

■ **Issued Date:** Jan. 21, 2016

FCC CERTIFICATION TEST REPORT

FOR

Applicant	:	Atoms Labs LLC
Address	:	2670 Firewheel Dr. Suite D Flower Mound, TX 75028 United States
Equipment under Test	:	Digital Wireless Weather Proof Camera
Model No	:	AWSC35
FCC ID	:	2ACMYAWSC35
Manufacturer	:	Atoms Labs LLC
Address	:	2670 Firewheel Dr. Suite D Flower Mound, TX 75028 United States

Issued By: Dongguan Dongdian Testing Service Co., Ltd.

Add: No. 17, Zongbu Road 2, Songshan Lake Sci&Tech, Industry Park, Dongguan City,
Guangdong Province, China, 523808

Tel: +86-0769-22891499 [Http://www.dgddt.com](http://www.dgddt.com)

REPORT

TABLE OF CONTENTS

- Test report declares.....4
- 1. Summary of test results 5
- 2. General test information..... 6
 - 2.1. Description of EUT 6
 - 2.2. Accessories of EUT..... 6
 - 2.3. Assistant equipment used for test..... 6
 - 2.4. Block diagram of EUT configuration for test 7
 - 2.5. Deviations of test standard 7
 - 2.6. Test environment conditions 7
 - 2.7. Test laboratory..... 7
 - 2.8. Measurement uncertainty 1
- 3. Equipment used during test 8
- 4. Maximum Peak Output Power 9
 - 4.1. Block diagram of test setup 9
 - 4.2. Limits 9
 - 4.3. Test Procedure..... 9
 - 4.4. Test Result..... 9
- 5. 20dB Bandwidth and 99% Bandwidth..... 9
 - 5.1. Block diagram of test setup 9
 - 5.2. Limits 9
 - 5.3. Test Procedure..... 9
 - 5.4. Test Result..... 10
 - 5.5. Original test data 10
- 6. Emissions outside the specified frequency bands 11
 - 6.1. Block diagram of test setup 11
 - 6.2. Limits 11
 - 6.3. Test Procedure..... 11
 - 6.4. Test Result..... 12
 - 6.5. Original test data 12
- 7. Carrier Frequency Separation..... 15
 - 7.1. Block diagram of test setup 15
 - 7.2. Limits 15
 - 7.3. Test Procedure..... 15
 - 7.4. Test Result..... 15
 - 7.5. Original test data 15
- 8. Number Of Hopping Channel 16

8.1.	Block diagram of test setup	16
8.2.	Limits	16
8.3.	Test Procedure.....	16
8.4.	Test Result.....	16
8.5.	Original test data	16
9.	Dwell Time.....	17
9.1.	Block diagram of test setup	17
9.2.	Limits	17
9.3.	Test Procedure.....	17
9.4.	Test Result.....	17
9.5.	Original test data	17
10.	Radiated emission	18
10.1.	Block diagram of test setup	18
10.2.	Limit	19
10.3.	Test Procedure.....	20
10.4.	Test result	21
11.	Band Edge Compliance	25
11.1.	Block diagram of test setup	25
11.2.	Limit	25
11.3.	Test Procedure.....	25
11.4.	Test result	25
12.	Power Line Conducted Emission	30
12.1.	Block diagram of test setup	30
12.2.	Power Line Conducted Emission Limits(Class B).....	30
12.3.	Test Procedure.....	30
12.4.	Test Result.....	31
13.	Antenna Requirements	34
13.1.	Limit	34
13.2.	Result.....	34
14.	Test setup photograph	35
15.	Photos of the EUT	37

TEST REPORT DECLARE

Applicant	:	Atoms Labs LLC
Address	:	2670 Firewheel Dr. Suite D Flower Mound, TX 75028 United States
Equipment under Test	:	Digital Wireless Weather Proof Camera
Model No	:	AWSC35
FCC ID	:	2ACMYAWSC35
Manufacturer	:	Atoms Labs LLC
Address	:	2670 Firewheel Dr. Suite D Flower Mound, TX 75028 United States

Test Standard Used: FCC Rules and Regulations Part 15 Subpart C: 2015, RSS-247 Issue 1 May 2015.

Test procedure used: ANSI C63.10:2013, ANSI C63.4:2014, RSS-Gen Issue 4, Nov. 2014.

We Declare:

The equipment described above is tested by Dongguan Dongdian Testing Service Co., Ltd and in the configuration tested the equipment complied with the standards specified above. The test results are contained in this test report and Dongguan Dongdian Testing Service Co., Ltd is assumed of full responsibility for the accuracy and completeness of these tests.

After test and evaluation, our opinion is that the equipment provided for test compliance with the requirement of the above FCC&IC standards.

Report No:	DDT-R16Q0105-5E1		
Date of Test:	Jan. 17, 2016~Jan. 21, 2016	Date of Report:	Jan. 21, 2016

Prepared By:

 Leo Liu/Engineer

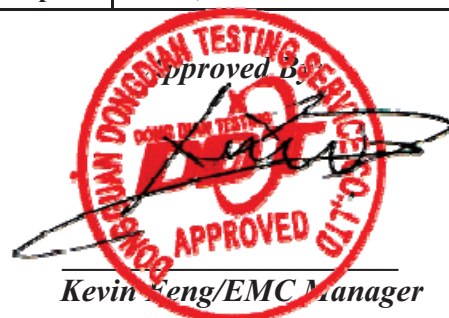
 Kevin Seng/EMC Manager

Note: This report applies to above tested sample only. This report shall not be reproduced in parts without written approval of Dongguan Dongdian Testing Service Co., Ltd.

1. Summary of test results

Description of Test Item	Standard	Results
Maximum Peak Output Power	FCC Part 15: 15.247(b)(1) ANSI C63.10 :2013 ANSI C63.4:2014 RSS-247 Issue 1 clause 5.1	PASS
20dB Bandwidth and 99% Bandwidth	FCC Part 15: 15.215 ANSI C63.10 :2013 ANSI C63.4:2014 RSS-247 Issue 1 clause 5.1	PASS
Emissions outside the specified frequency bands	FCC Part 15: 15.247(a)(1) ANSI C63.10 :2013 ANSI C63.4:2014 RSS-247 Issue 1 clause 5.1	PASS
Carrier Frequency Separation	FCC Part 15: 15.247(a)(1)(iii) ANSI C63.10 :2013 ANSI C63.4:2014 RSS-247 Issue 1 clause 5.1	PASS
Number Of Hopping Channel	FCC Part 15: 15.247(a)(1)(iii) ANSI C63.10 :2013 ANSI C63.4:2014 RSS-247 Issue 1 clause 5.1	PASS
Dwell Time	FCC Part 15: 15.209 FCC Part 15: 15.247(d) ANSI C63.10 :2013 ANSI C63.4:2014 RSS-247 Issue 1 clause 5.1 RSS-Gen Issue 4 clause 7.2.2 RSS-Gen Issue 4 clause 7.2.5	PASS
Radiated Emission	FCC Part 15: 15.247(d) ANSI C63.10 :2013 ANSI C63.4:2014 RSS-247 Issue 1 clause 5.1 RSS-Gen Issue 4 clause 7.2.2 RSS-Gen Issue 4 clause 7.2.5	PASS
Band Edge Compliance	FCC Part 15: 15.207 ANSI C63.10 :2013 ANSI C63.4:2014 RSS-Gen Issue 4 clause 7.2.4	PASS
Power Line Conducted Emissions	FCC Part 15: 15.203 ANSI C63.4:2014 RSS-Gen Issue 4 clause 7.1.2	N/A
Antenna requirement	FCC Part 15: 15.247(b)(1) ANSI C63.10 :2013 ANSI C63.4:2014 RSS-247 Issue 1 clause 5.1	PASS
Note: N/A is an abbreviation for Not Applicable.		

2. General test information

2.1. Description of EUT

EUT* Name	: Digital Wireless Weather Proof Camera
Model Number	: AWSC35
EUT function description	: Please reference user manual of this device
Type of EUT	: Stand-alone
Power supply	: DC 5V From adapter
Radio Specification	: Non
Operation frequency	: 2414.25MHz~2461.50MHz (Channel 1~Channel 15)
Modulation Types	: Frequency Hopping Spread Spectrum (FHSS) modulation.
Equipment type	: Non-Adaptive frequency hopping equipment.
Hopping Frequency Separation	: 3.375MHz
Antenna Type	: External antenna, Antenna gain: 2.0dBi
Date of Receipt	: 2016/01/17
Sample Type	: Series production

Note1: EUT is the ab. of equipment under test.

Channle information							
CH	Frequency	CH	Frequency	CH	Frequency	CH	Frequency
1	2414.25MHz	5	2427.75MHz	9	2441.25MHz	13	2454.75MHz
2	2417.625MHz	6	2431.125MHz	10	2444.625MHz	14	2458.125MHz
3	2421MHz	7	2434.5MHz	11	2448MHz	15	2461.50MHz
4	2424.375MHz	8	2437.875MHz	12	2451.375MHz	/	/

2.2. Accessories of EUT

Description of Accessories	Manufacturer	Model number or Type	Output.	Difference
AC/AD ADAPTOR (Ktec)	Kuantech (Beihai) Co., Ltd.	KSAS0050500100VUD	5V/1A	Only plug type
AC ADAPTOR (Csec)	Chou Sen Electronics (shenzhen) Co., Ltd	CSSD050100FUF		Only plug type
SWITCHING ADAPTER (3E)	Dongguan City Gangqi Electronics Co., Ltd	GQ15-050100-AU		Only plug type

Note: After the preliminary scan, EUT powered from external power (Csec) adapter will have highest emission, was selected and recorded in this report.

2.3. Assistant equipment used for test

Description of Assistant equipment	Manufacturer	Model number or Type	EMC Compliance	SN
/	/	/	/	/

2.4. Block diagram of EUT configuration for test

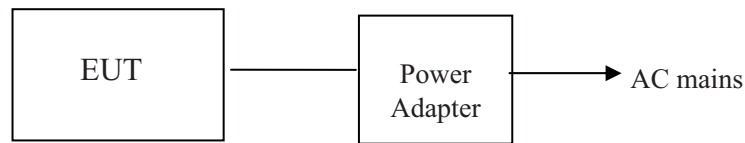

EUT was connected to control to a special test jig provided by manufacturer which has a USB connect to Notebook, and the Notebook will run a special test software provided by manufacturer to control EUT work in Continuous TX mode (>98% duty cycle), and select test channel, wireless mode and data rate.

Tested mode, channel, information		
Mode	Channel	Frequency (MHz)
Normal hopping mode	CH1 to CH1	2414.25 to 2461.50
Fixed channel mode	CH1, CH8, CH15	2414.25, 2437.875, 2461.50

2.5. Deviations of test standard

No Deviation

2.6. Test environment conditions

During the measurement the environmental conditions were within the listed ranges:

Temperature range:	21-25°C
Humidity range:	40-75%
Pressure range:	86-106kPa

2.7. Test laboratory

Dongguan Dongdian Testing Service Co., Ltd

Add: No. 17, Zongbu Road 2, Songshan Lake Sci&Tech, Industry Park, Dongguan City, Guangdong Province, China, 523808 Tel: +86-0769-22891499 <http://www.dgddt.com>

FCC Registration Number: 270092 Industry Canada site registration number: 10288A-1

2.8. Measurement uncertainty

Test Item	Uncertainty
Bandwidth	±1.1%
Peak Output Power(Conducted)(Spectrum analyzer)	0.86dB(10 MHz ≤ f < 3.6GHz);
	1.38dB(3.6GHz ≤ f < 8GHz)
Peak Output Power(Conducted)(Power Sensor)	0.74dB
Dwell Time	±0.6%
Conducted spurious emissions	0.86dB(10 MHz ≤ f < 3.6GHz);
	1.40dB(3.6GHz ≤ f < 8GHz)
	1.66dB(8GHz ≤ f < 22GHz)
Uncertainty for radio frequency (RBW<20KHz)	3×10-8

Temperature	±0.4℃
Humidity	±2%
Uncertainty for Radiation Emission test (30MHz-1GHz)	±3.14 dB (Antenna Polarize: V)
	±3.16 dB (Antenna Polarize: H)
Uncertainty for Radiation Emission test (1GHz-18GHz)	±4.14dB(1-6GHz)
	±4.46dB (6GHz-18Gz)
Uncertainty for Power line conduction emission test	2.44dB (150KHz-30MHz)
Note: This uncertainty represents an expanded uncertainty expressed at approximately the 95% confidence level using a coverage factor of k=2.	

3. Equipment used during test

Equipment	Manufacturer	Model No.	Serial No.	Last Cal.	Cal. Interval
RF Connected Test					
Spectrum analyzer	R&S	FSU26	1166.1660.26	2015/10/24	1 Year
Attenuator	Mini-Circuits	BW-S10W2	101109	2015/08/18	1 Year
RF Cable	Micable	C10-01-01-1	100309	2015/08/18	1 Year
Radiated Emission Test					
EMI Test Receiver	R&S	ESU8	100316	2015/10/24	1Year
Spectrum analyzer	R&S	FSU26	1166.1660.26	2015/10/24	1Year
Trilog Broadband Antenna	Schwarzbeck	VULB9163	9163-462	2015/05/30	1 Year
Active Loop antenna	Schwarzbeck	FMZB-1519	1519-038	2015/10/24	1 Year
Double Ridged Horn Antenna	R&S	HF907	100276	2015/10/31	1 Year
Pre-amplifier	A.H.	PAM-0118	360	2015/08/18	1 Year
RF Cable	HUBSER	CP-X2	W11.03	2015/10/24	1Year
RF Cable	HUBSER	CP-X1	W12.02	2015/10/24	1 Year
MI Cable	HUBSER	C10-01-01-1M	1091629	2015/10/24	1 Year
Test software	Audix	E3	V 6.11111b	/	/
Power Line Conducted Emissions Test					
Test Receiver	R&S	ESU8	100316	2015/10/24	1 Year
LISN 1	R&S	ENV216	101109	2015/10/24	1 Year
LISN 2	R&S	ESH2-Z5	100309	2015/10/24	1 Year
Pulse Limiter	R&S	ESH3-Z2	101242	2015/10/24	1 Year
CE Cable 1	HUBSER	ESU8/RF2	W10.01	2015/10/24	1 Year
Test software	Audix	E3	V 6.11111b	/	/

4. Maximum Peak Output Power

4.1. Block diagram of test setup

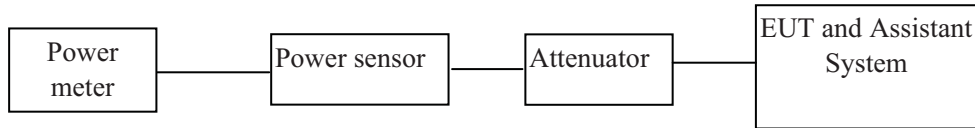

4.2. Limits

For systems using digital modulation in the 902-928 MHz, 2400-2483.5 MHz, and 5725-5850 MHz bands: 1 Watt. If transmitting antennas of directional gain greater than 6 dBi are used, the conducted output power from the intentional radiator shall be reduced below the stated values as appropriate, by the amount in dB that the directional gain of the antenna exceeds 6 dBi.

4.3. Test Procedure

- (1) Connect each EUT's antenna output to power sensor by RF cable and attenuator
- (2) Measure out the Average and PK output power of each antenna port by power meter.

4.4. Test Result

Mode	Freq (MHz)	Result (dBm)	Limit (dBm)	Conclusion
Fixed channel mode	2414.25	17.40	21	PASS
	2437.875	17.42	21	PASS
	2461.50	17.31	21	PASS
Test Date : 2016/01/19			Test Engineer : Leo	

5. 20dB Bandwidth and 99% Bandwidth

5.1. Block diagram of test setup

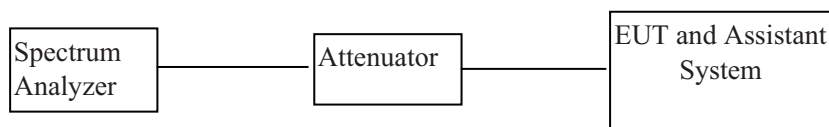

5.2. Limits

Intentional radiators operating under the alternative provisions to the general emission limits, as contained in § 15.217 through 15.257 and in Subpart E of this part, must be designed to ensure that the 20 dB bandwidth of the emission, or whatever bandwidth may otherwise be specified in the specific rule section under which the equipment operates, is contained within the frequency band designated in the rule section under which the equipment is operated.

5.3. Test Procedure

- (1) Connect EUT's antenna output to spectrum analyzer by RF cable.
- (2) The bandwidth of the fundamental frequency was measured by spectrum analyzer with 100 kHz RBW

and 300 kHz VBW. The 20dB bandwidth is defined as the total spectrum the power of which is higher than peak power minus 20dB.

5.4. Test Result

Mode	Freq (MHz)	20dB bandwidth Result (MHz)	99% bandwidth Result (MHz)	Limit (MHz)	Conclusion
Fixed channel mode	2414.25	3.38	3.46	/	PASS
	2437.875	3.38	3.48	/	PASS
	2461.50	3.38	3.48	/	PASS

Test Date : 2016/01/19 Test Engineer : Leo

5.5. Original test data

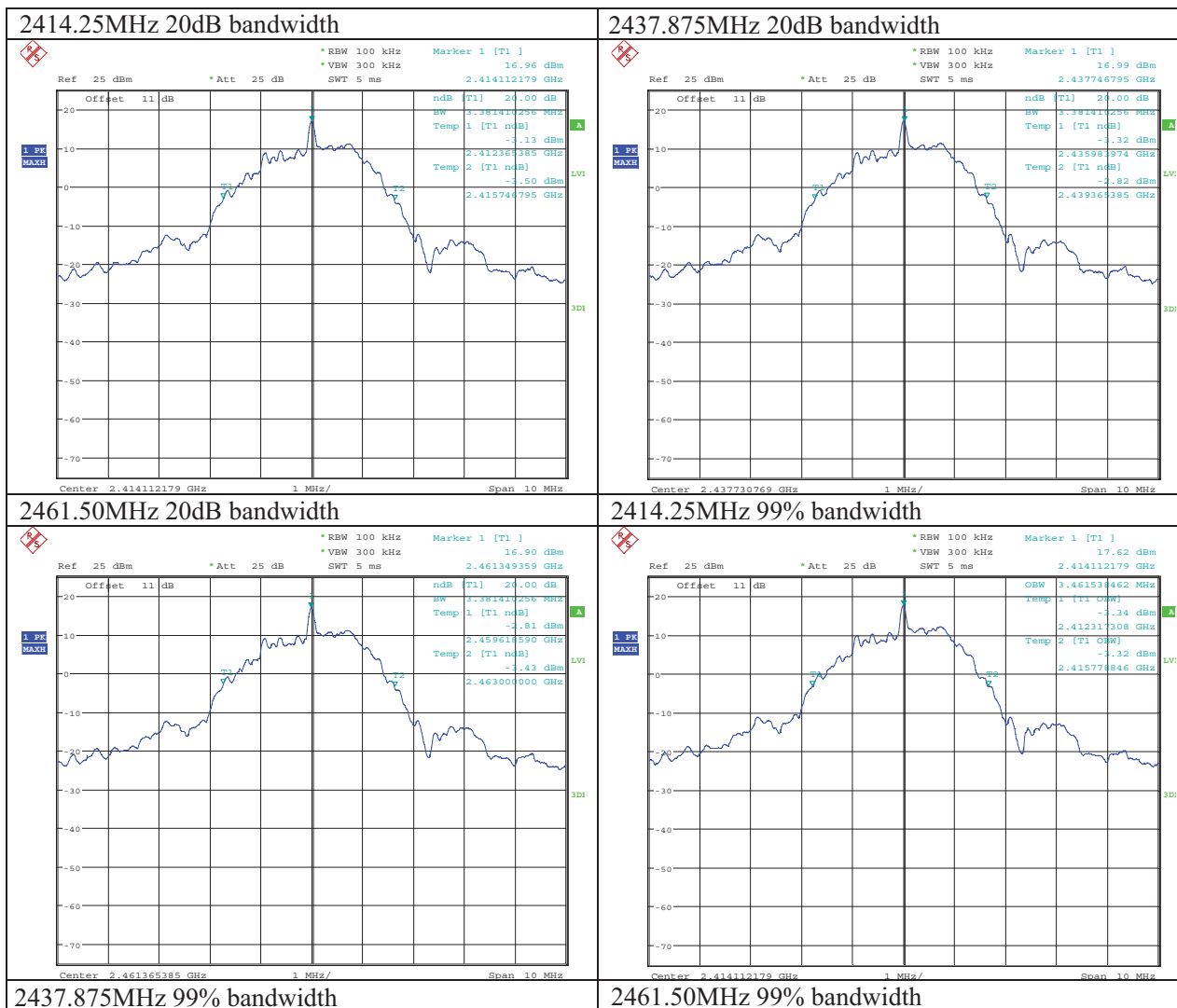

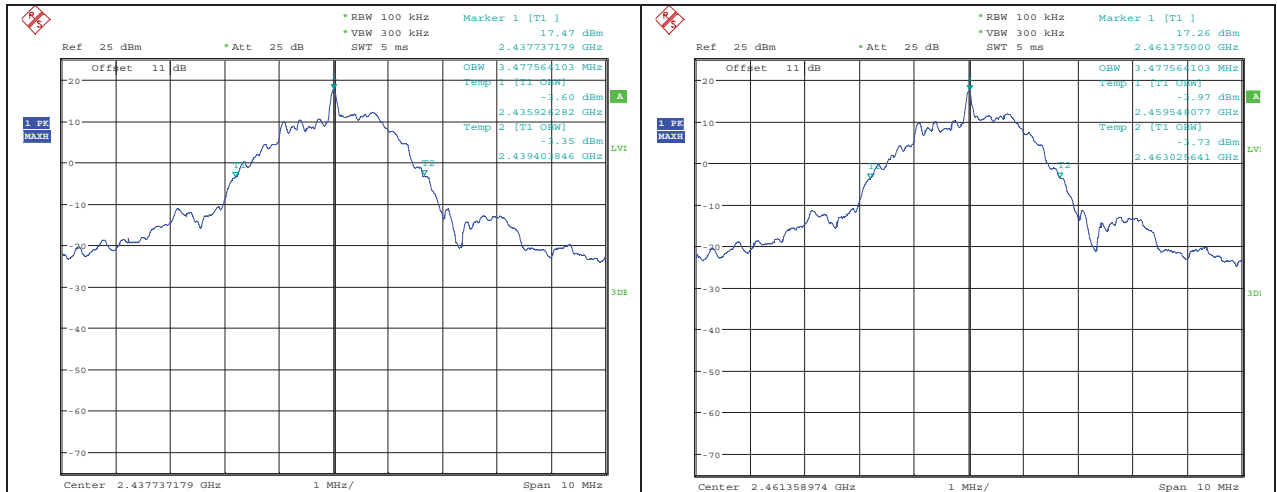

6. Emissions outside the specified frequency bands

6.1. Block diagram of test setup

Same with 5.1

6.2. Limits

In any 100kHz bandwidth outside the frequency bands in which the spread spectrum intentional radiator is operating, the radio frequency power that is produced by the intentional radiator shall be at least 20dB below that in the 100kHz bandwidth within the band that contains the highest level of the desired power.

6.3. Test Procedure

- (1) Connect EUT's antenna output to spectrum analyzer by RF cable.
- (2) Establish a reference level by using the following procedure:

Center frequency	Channel center frequency
RBW:	100KHz
VBW:	300KHz
Span	1.5times the bandwidth
Detector Mode:	Peak
Sweep time:	auto
Trace mode	Max hold

- (3) Allow the trace to stabilize, use the peak marker function to determine the maximum peak power level to establish the reference level.
- (4) Set the spectrum analyzer as follows:

RBW:	100KHz
VBW:	300KHz
Span	Encompass frequency range to be measured

Number of measurement points \geq span/RBW
 Detector Mode: Peak
 Sweep time: auto
 Trace mode Max hold

(5) Allow the trace to stabilize, use the peak marker function to determine the maximum amplitude of all unwanted emissions outside of the authorized frequency band

6.4. Test Result

EUT Set Mode	CH or Frequency	Measured Range	Result (dBm)
TX mode	2414.25MHz	30MHz-1GHz	PASS
		1GHz-25GHz	PASS
		2.339GHz-2.4065GHz	PASS
	2437.875MHz	30MHz-1GHz	PASS
		1GHz-25GHz	PASS
		30MHz-1GHz	PASS
	2461.50MHz	1GHz-25GHz	PASS
		2.472GHz-2.484GHz	PASS
		Hopping on	2.39GHz-2.50GHz

Test Date : 2016/01/19 Test Engineer : Leo

6.5. Original test data

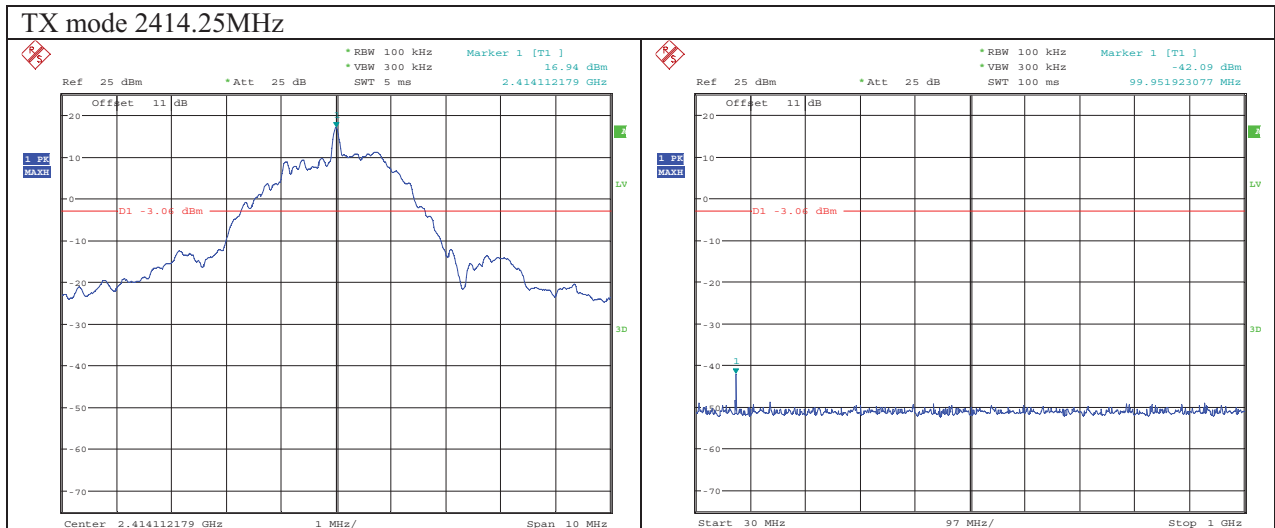

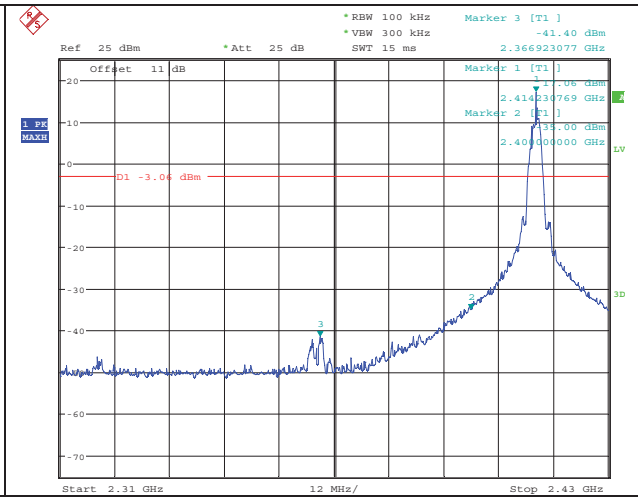
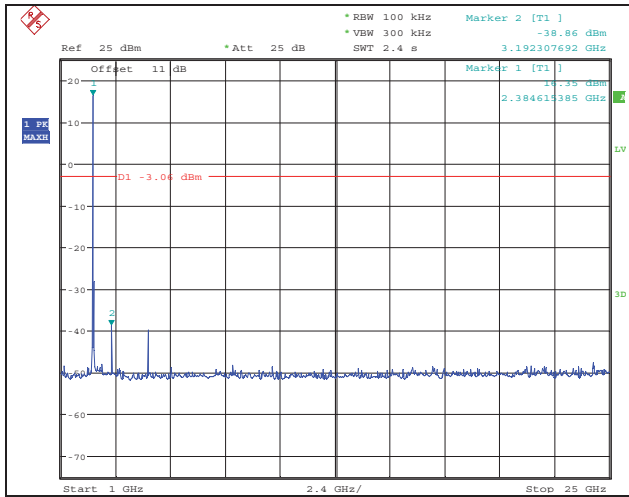

TX mode 2437.875MHz

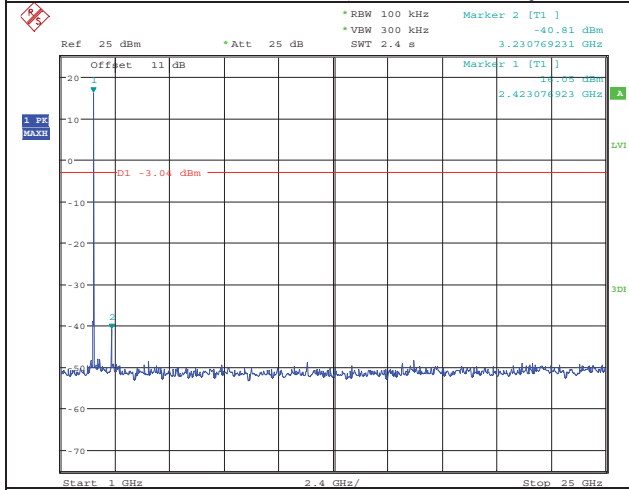
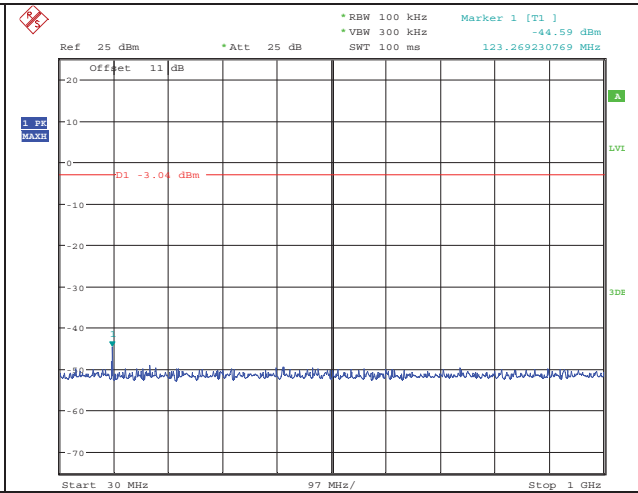
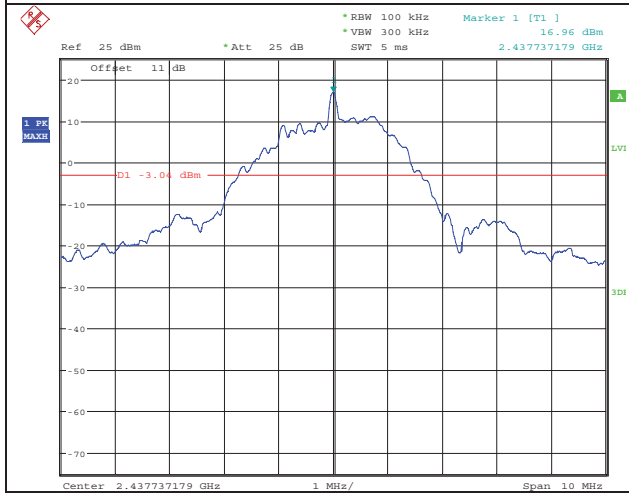

TX mode 2461.50MHz

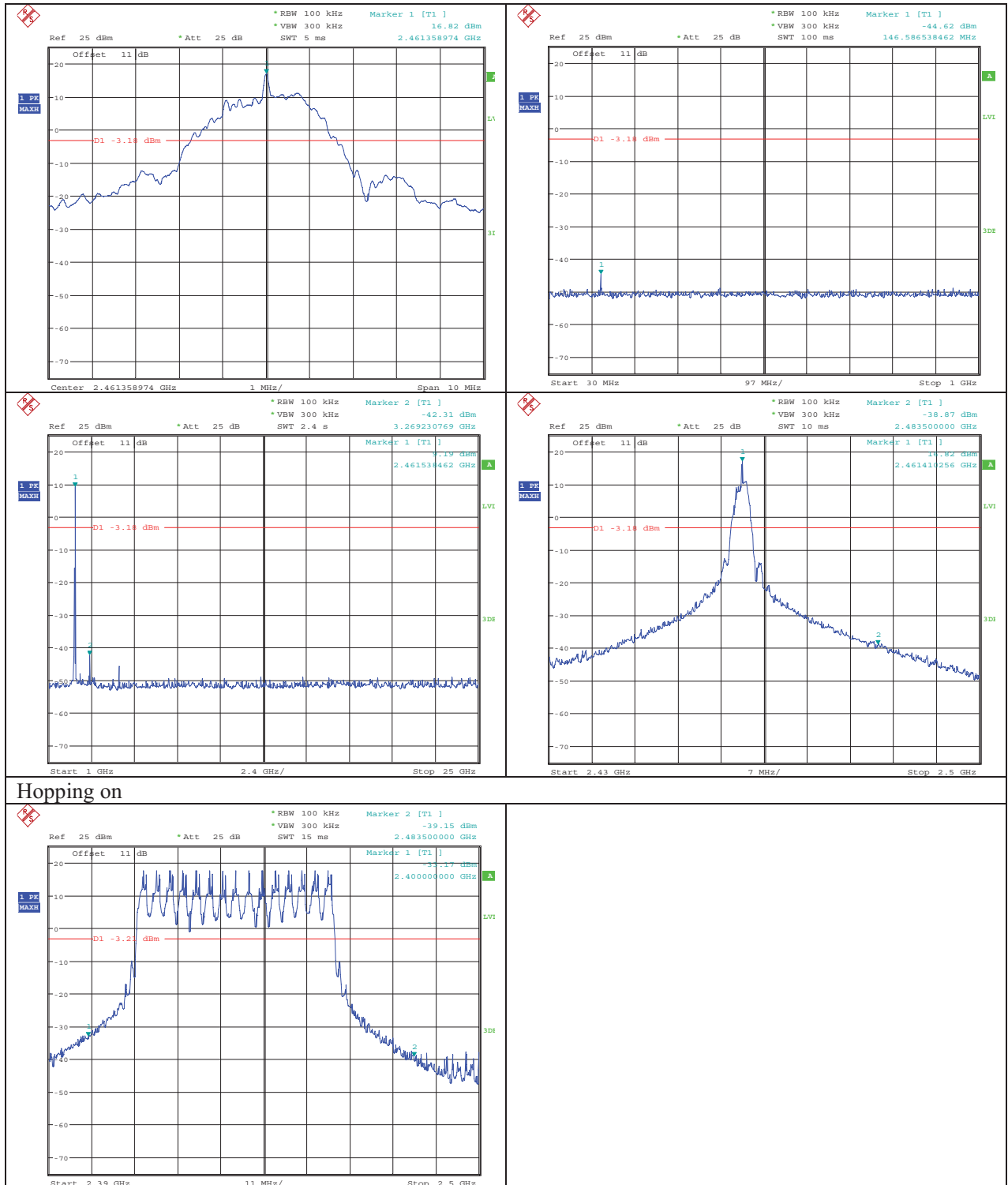

7. Carrier Frequency Separation

7.1. Block diagram of test setup

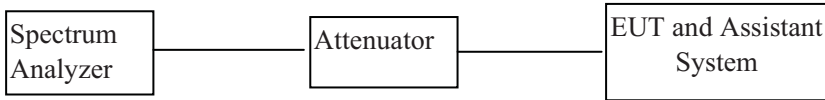

7.2. Limits

Frequency hopping systems shall have hopping channel carrier frequencies separated by a minimum of 25 kHz or the 20 dB bandwidth of the hopping channel, whichever is greater. Alternatively, frequency hopping systems operating in the 2400-2483.5 MHz band may have hopping channel carrier frequencies that are separated by 25 kHz or two-thirds of the 20 dB bandwidth of the hopping channel, whichever is greater, provided the systems operate with an output power no greater than 125 mW.

7.3. Test Procedure

- (1) Connect EUT’s antenna output to spectrum analyzer by RF cable.
- (2) The carrier frequency was measured by spectrum analyzer with 100 KHz RBW and 300KHz VBW.

7.4. Test Result

Mode	Channel separation (MHz)	20dB Bandwidth (MHz)	Limit (MHz) 2/3 of 20dB bandwidth	Conclusion
Normal hopping mode	3.413	3.38	2.25	PASS
Test Date : 2016/01/19			Test Engineer : Leo	

7.5. Original test data

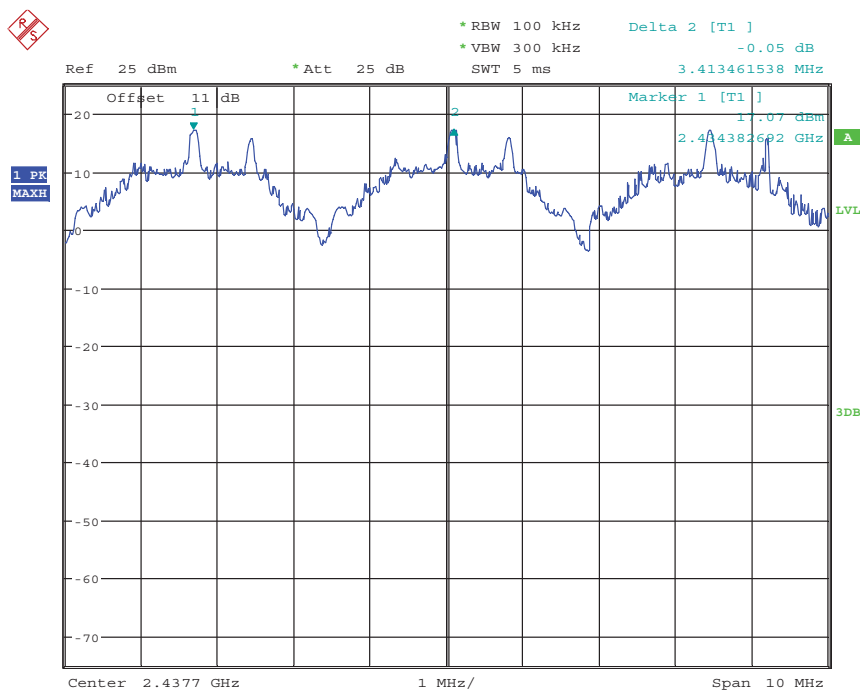

8. Number Of Hopping Channel

8.1. Block diagram of test setup

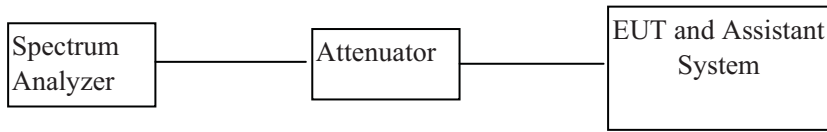

8.2. Limits

Frequency hopping systems in the 2400-2483.5 MHz band shall use at least 15 channels.

8.3. Test Procedure

- (1) Connect EUT's antenna output to spectrum analyzer by RF cable.
- (2) The number of hopping channel was measured by spectrum analyzer with 100 kHz RBW and 300 kHz VBW.

8.4. Test Result

Mode	Number of hopping channel	Limit	Conclusion
Normal hopping mode	15	≥ 15	PASS
Test Date : 2016/01/19		Test Engineer : Leo	

8.5. Original test data

Numbers of Hopping Channel are 15 Channel

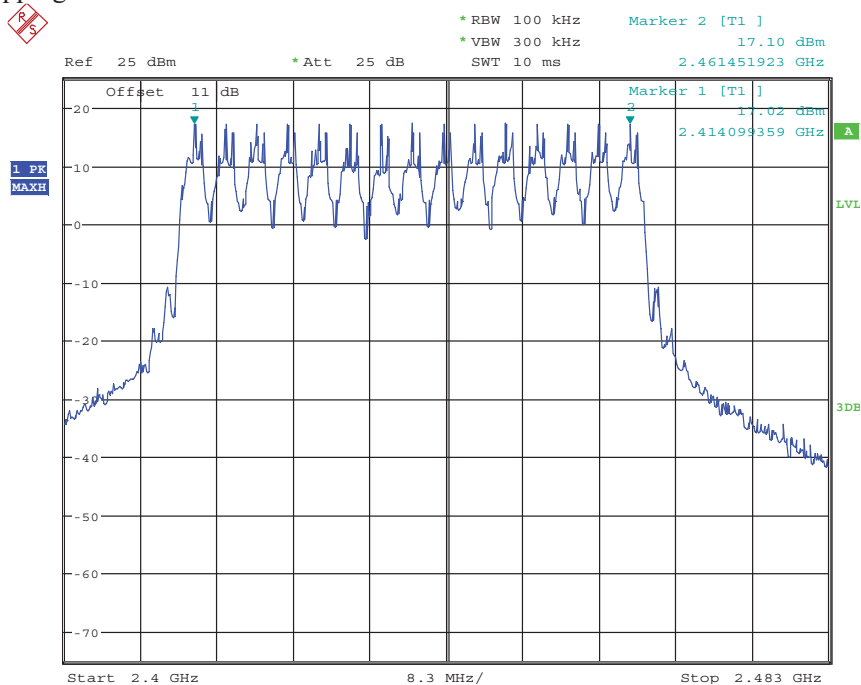

9. Dwell Time

9.1. Block diagram of test setup

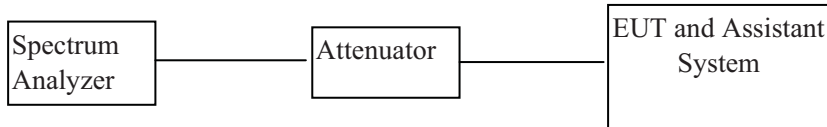

9.2. Limits

The average time of occupancy on any channel shall not be greater than 0.4 seconds within a period of 0.4 seconds multiplied by the number of hopping channels employed.

9.3. Test Procedure

- (1) Connect EUT’s antenna output to spectrum analyzer by RF cable.
- (2) Measure the hopping number and on time of each pulse with spectrum analyzer in zero span set, and calculate dwell time with formula Dwell time = Hopping number/measure time *0.4*15*pulse’s on time

9.4. Test Result

Mode	Dwell time	Limit	Conclusion
Normal hopping mode	0.354s	<400ms	PASS
Test Date : 2016/01/19		Test Engineer : Leo	

9.5. Original test data

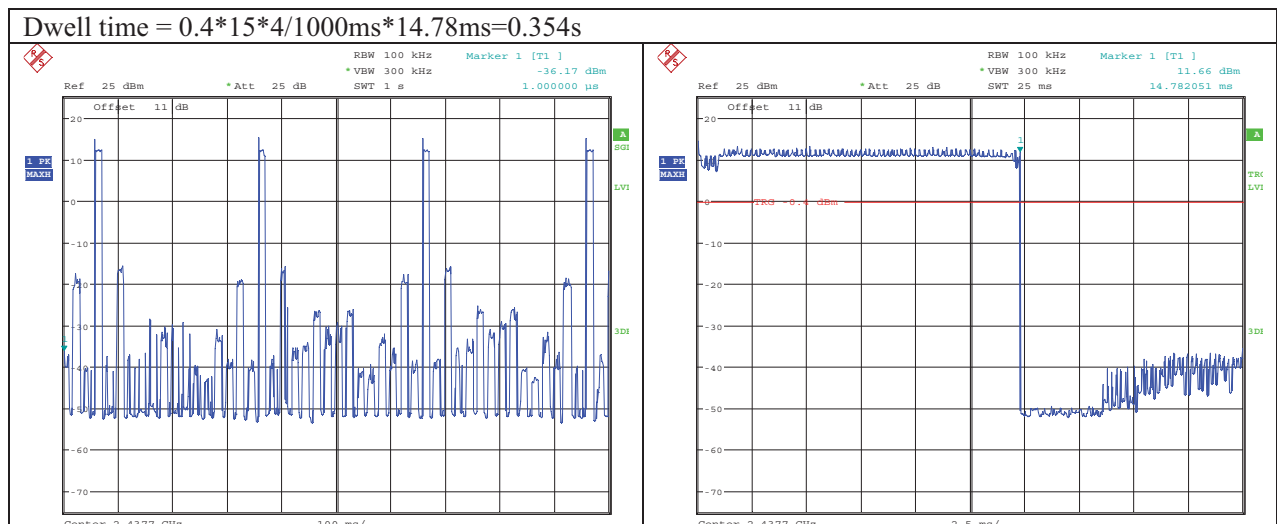

10. Radiated emission

10.1. Block diagram of test setup

In 3m Anechoic Chamber Test Setup Diagram for 9KHz-30MHz

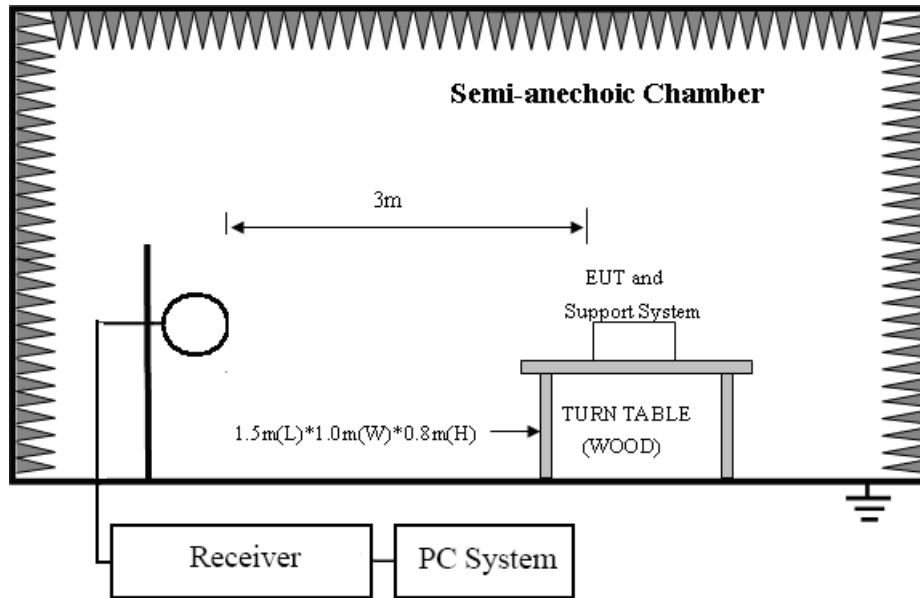

In 3m Anechoic Chamber Test Setup Diagram for below 1GHz

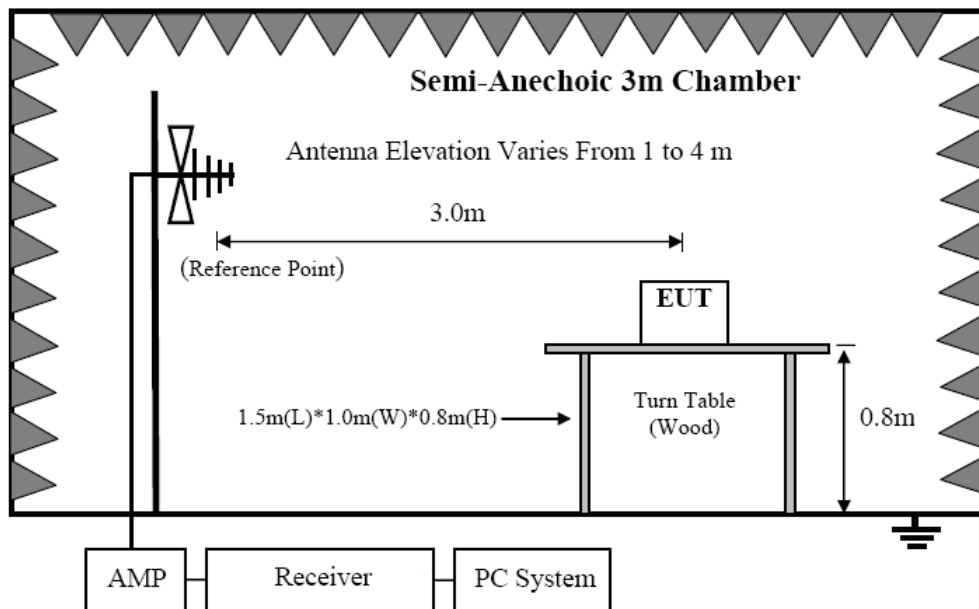

In 3m Anechoic Chamber Test Setup Diagram for frequency above 1GHz

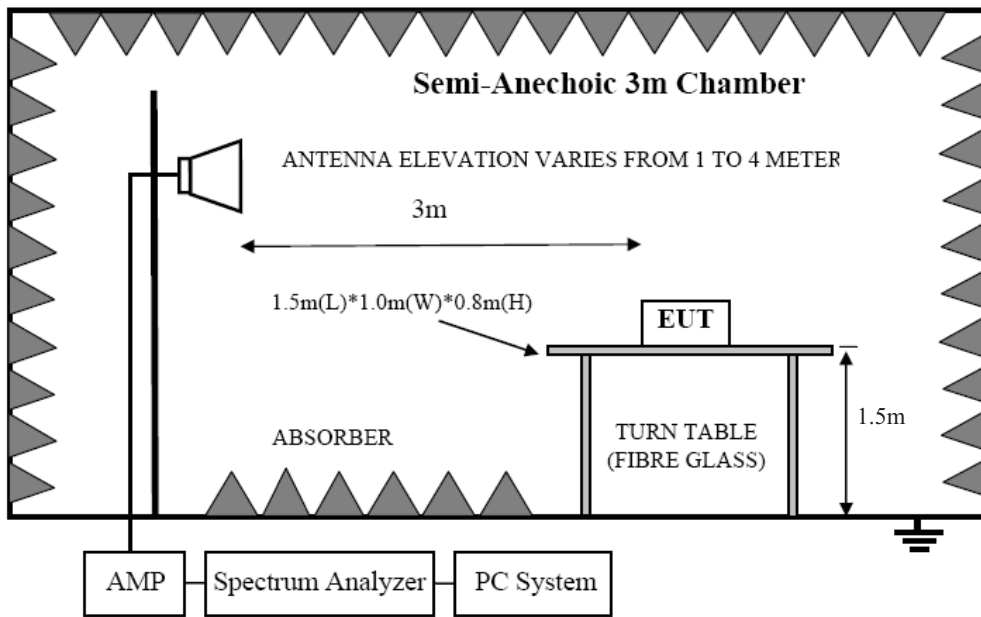

Note: For harmonic emissions test a appropriate high pass filter was inserted in the input port of AMP.

10.2. Limit

10.2.1 FCC 15.205 Restricted frequency band

MHz	MHz	MHz	GHz
0.090 - 0.110	16.42 - 16.423	399.9 - 410	4.5 - 5.15
¹ 0.495 - 0.505	16.69475 - 16.69525	608 - 614	5.35 - 5.46
2.1735 - 2.1905	16.80425 - 16.80475	960 - 1240	7.25 - 7.75
4.125 - 4.128	25.5 - 25.67	1300 - 1427	8.025 - 8.5
4.17725 - 4.17775	37.5 - 38.25	1435 - 1626.5	9.0 - 9.2
4.20725 - 4.20775	73 - 74.6	1645.5 - 1646.5	9.3 - 9.5
6.215 - 6.218	74.8 - 75.2	1660 - 1710	10.6 - 12.7
6.26775 - 6.26825	108 - 121.94	1718.8 - 1722.2	13.25 - 13.4
6.31175 - 6.31225	123 - 138	2200 - 2300	14.47 - 14.5
8.291 - 8.294	149.9 - 150.05	2310 - 2390	15.35 - 16.2
8.362 - 8.366	156.52475 - 156.52525	2483.5 - 2500	17.7 - 21.4
8.37625 - 8.38675	156.7 - 156.9	2690 - 2900	22.01 - 23.12
8.41425 - 8.41475	162.0125 - 167.17	3260 - 3267	23.6 - 24.0
12.29 - 12.293	167.72 - 173.2	3332 - 3339	31.2 - 31.8
12.51975 - 12.52025	240 - 285	3345.8 - 3358	36.43 - 36.5
12.57675 - 12.57725	322 - 335.4	3600 - 4400	(²)

10.2.2 FCC 15.209 Limit.

FREQUENCY MHz	DISTANCE Meters	FIELD STRENGTHS LIMIT	
		μV/m	dB(μV)/m
0.009 ~ 0.490	300	2400/F(KHz)	67.6-20log(F)
0.490 ~ 1.705	30	24000/F(KHz)	87.6-20log(F)
1.705 ~ 30.0	30	30	29.54
30 ~ 88	3	100	40.0

88 ~ 216	3	150	43.5
216 ~ 960	3	200	46.0
960 ~ 1000	3	500	54.0
Above 1000	3	74.0 dB(μ V)/m (Peak) 54.0 dB(μ V)/m (Average)	

Note: (1) The emission limits shown in the above table are based on measurements employing a CISPR QP detector except for the frequency bands 9-90KHz, 110-490KHz and above 1000MHz. Radiated emissions limits in these three bands are based on measurements employing an average detector.

(2) At frequencies below 30MHz, measurement may be performed at a distance closer than that specified, and the limit at closer measurement distance can be extrapolated by below formula:

$$\text{Limit}_{3m}(\text{dB}\mu\text{V}/\text{m}) = \text{Limit}_{30m}(\text{dB}\mu\text{V}/\text{m}) + 40\text{Log}(30\text{m}/3\text{m})$$

10.2.3 Limit for this EUT

All the emissions appearing within 15.205 restricted frequency bands shall not exceed the limits shown in 15.209, all the other emissions shall be at least 20dB below the fundamental emissions, or comply with 15.209 limits.

10.3. Test Procedure

(1) EUT height should be 0.8m for below 1GHz at a semi - anechoic chamber while EUT height should be 1.5m for above 1GHz at full chamber or semi - anechoic chamber ground with absorbers.

(2) Test antenna was located 3m from the EUT on an adjustable mast, and the antenna used as below table.

Test frequency range	Test antenna used
9KHz-30MHz	Active Loop antenna
30MHz-1GHz	Trilog Broadband Antenna
1GHz-18GHz	Double Ridged Horn Antenna(1GHz-18GHz)
18GHz-40GHz	Horn Antenna(18GHz-40GHz)

According ANSI C63.10:2013 clause 6.4.4.2 and 6.5.3, for measurements below 30 MHz, the loop antenna was positioned with its plane vertical from the EUT and rotated about its vertical axis for maximum response at each azimuth position around the EUT. And the loop antenna also be positioned with its plane horizontal at the specified distance from the EUT. The center of the loop is 1 m above the ground. for measurement above 30MHz, the Trilog Broadband Antenna or Horn Antenna was located 3m from EUT, Measurements were made with the antenna positioned in both the horizontal and vertical planes of Polarization, and the measurement antenna was varied from 1 m to 4 m. in height above the reference ground plane to obtain the maximum signal strength.

(3) Below pre-scan procedure was first performed in order to find prominent frequency spectrum radiated emissions from 9KHz to 25GHz:

(a) Scanning the peak frequency spectrum with the antenna specified in step (3), and the EUT was rotated 360 degree, the antenna height was varied from 1m to 4m(Except loop antenna, it's fixed 1m above ground.)

(b) Change work frequency or channel of device if practicable.

(c) Change modulation type of device if practicable.

(d) Change power supply range from 85% to 115% of the rated supply voltage

(e) Rotated EUT though three orthogonal axes to determine the attitude of EUT arrangement produces highest emissions.

Spectrum frequency from 9KHz to 25GHz (tenth harmonic of fundamental frequency) was investigated, and no any obvious emission were detected from 18GHz to 25GHz, so below final test was performed with frequency range from 9KHz to 18GHz.

- (4) For final emissions measurements at each frequency of interest, the EUT was rotated and the antenna height was varied between 1m and 4m in order to maximize the emission. Measurements in both horizontal and vertical polarities were made and the data was recorded. In order to find the maximum emission, the relative positions of equipments and all of the interface cables were changed according to ANSI C63.10 2013 on Radiated Emission test.
- (5) The emissions from 9KHz to 1GHz were measured based on CISPR QP detector except for the frequency bands 9-90KHz, 110-490KHz, for emissions from 9KHz-90KHz,110KHz-490KHz and above 1GHz were measured based on average detector, for emissions above 1GHz, peak emissions also be measured and need comply with Peak limit.
- (6) The emissions from 9KHz to 1GHz, QP or average values were measured with EMI receiver with below RBW

Frequency band	RBW
9KHz-150KHz	200Hz
150KHz-30MHz	9KHz
30MHz-1GHz	120KHz

- (6) For emissions above 1GHz, both Peak and Average level were measured with Spectrum Analyzer, and the RBW is set at 1MHz, VBW is set at 3MHz for Peak measure; RMS detector RBW 1MHz VBW 3MHz for Average measure(according ANSI C63.10:2013 clause 4.2.3.2.3 procedure for average measure).
- (7) X axis, Y axis, Z axis are tested, and worse setup X axis is reported.

10.4. Test result

PASS. (See below detailed test result)

All the emissions except fundamental emission from 9 KHz to 25GHz were comply with 15.209 limit.

Note1: According exploratory test no any obvious emission were detected from 9KHz to 30MHz

and 18GHz to 25GHz, so the final test was performed with frequency range from 30MHz to 18GHz and recorded in below.

Note2: For emissions below 1GHz, according exploratory explorer test, when change Tx mode and channel, have no distinct influence on emissions level, so for emissions below 1GHz, the final test was only performed with EUT working in Tx Mode Middle CH mode.

Note3: For below test data, when the limit tabular marked “/” means this frequency point is the fundamental emission and no need comply with this limit.

Radiated Emission test (below 1GHz)

TR-4-E-009 Radiated Emission Test Result

Test Site : DDT 3m Chamber **E:\2016 Report Data\16Q0105-5\RE.EM6**
Test Date : 2016-01-17 **Tested By** : Toby
EUT : Digital Wireless Weather Proof Camera **Model Number** : AWS35
Power Supply : DC 5V from adapter **Test Mode** : TX Mode
Condition : Temp:24.5°C,Humi:55%, Press:100.1kPa **Antenna/Distance** : 2014 VULB 9163/3m/HORIZONTAL
Memo : Adapter: Csec

Data: 7

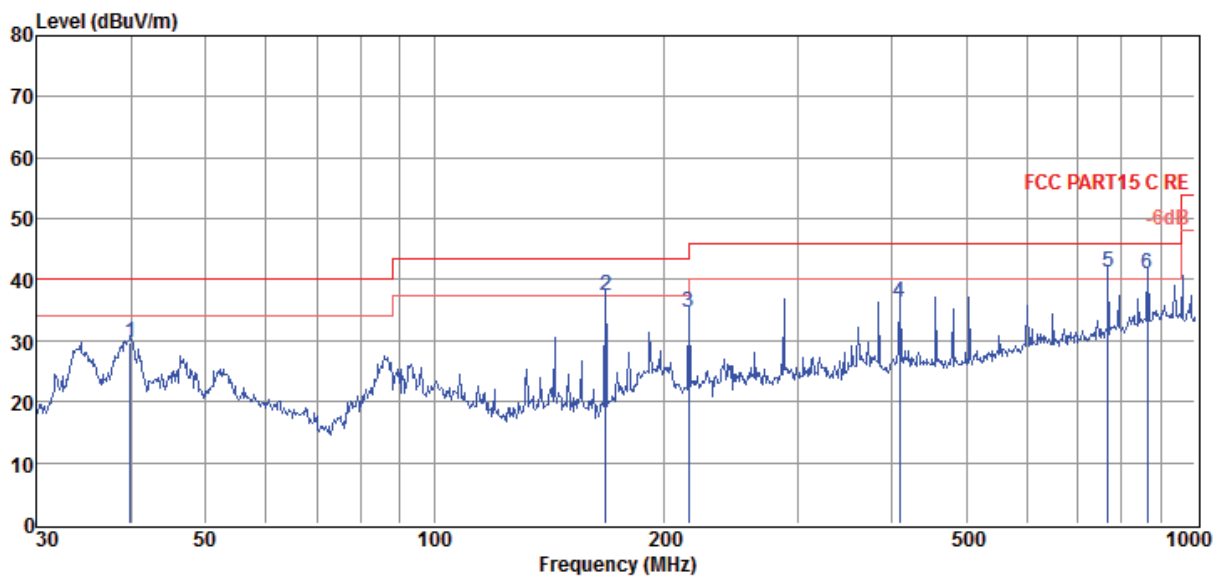

Item (Mark)	Freq (MHz)	Read Level (dBμV)	Antenna Factor (dB/m)	Cable Loss dB	Result Level (dBμV/m)	Limit Line (dBμV/m)	Over Limit (dB)	Detector	Polarization
1	39.85	11.87	14.00	3.79	29.66	40.00	-10.34	QP	HORIZONTAL
2	167.82	23.97	8.50	4.79	37.26	43.50	-6.24	QP	HORIZONTAL
3	216.02	19.42	10.33	4.97	34.72	46.00	-11.28	QP	HORIZONTAL
4	408.95	14.60	15.91	5.82	36.33	46.00	-9.67	QP	HORIZONTAL
5	768.75	14.22	19.93	7.03	41.18	46.00	-4.82	QP	HORIZONTAL
6	866.09	12.09	21.65	7.33	41.07	46.00	-4.93	QP	HORIZONTAL

- Note: 1. Result Level = Read Level + Antenna Factor + Cable loss.
 2. If Peak Result complies with QP limit, QP Result is deemed to comply with QP limit.
 3. Test setup: RBW: 120 kHz, VBW: 300 kHz, Sweep time: auto.

TR-4-E-009 Radiated Emission Test Result

Test Site : DDT 3m Chamber E:\2016 Report Data\16Q0105-5\RE.EM6
Test Date : 2016-01-17 **Tested By** : Toby
EUT : Digital Wireless Weather Proof Camera **Model Number** : AWSC35
Power Supply : DC 5V from adapter **Test Mode** : TX Mode
Condition : Temp:24.5'C,Humi:55%, Press:100.1kPa **Antenna/Distance** : 2014 VULB 9163/3m/VERTICAL
Memo : Adapter: Csec

Data: 8

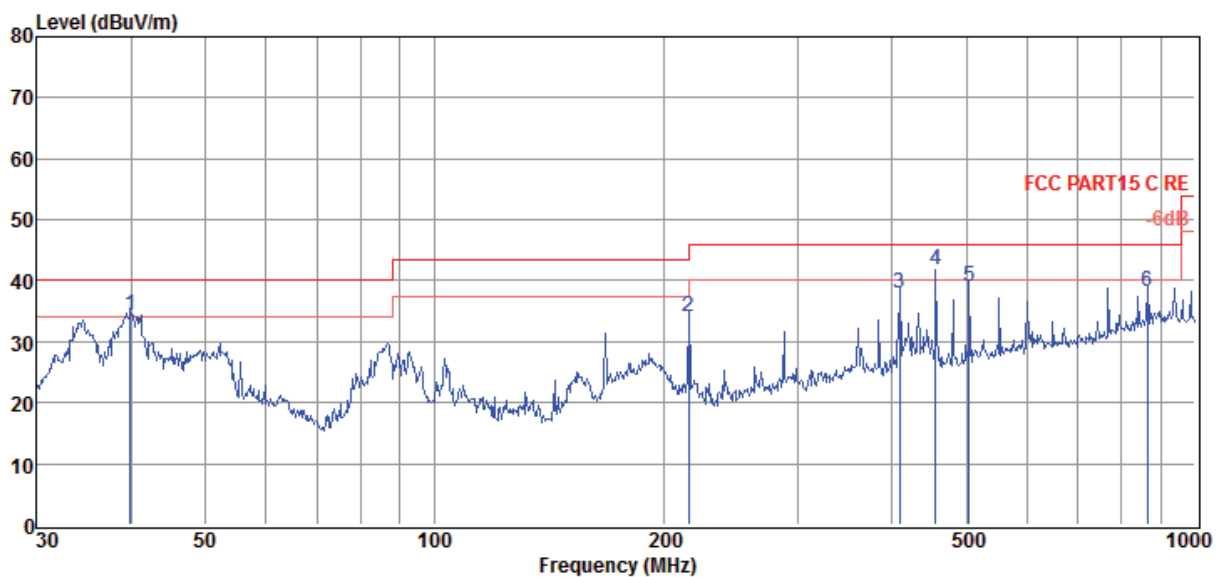

Item (Mark)	Freq (MHz)	Read Level (dBuV)	Antenna Factor (dB/m)	Cable Loss (dB)	Result Level (dBuV/m)	Limit Line (dBuV/m)	Over Limit (dB)	Detector	Polarization
1	39.85	16.57	14.00	3.79	34.36	40.00	-5.64	QP	VERTICAL
2	216.02	18.68	10.33	4.97	33.98	46.00	-12.02	QP	VERTICAL
3	408.95	16.34	15.91	5.82	38.07	46.00	-7.93	QP	VERTICAL
4	455.91	19.78	15.96	6.02	41.76	46.00	-4.24	QP	VERTICAL
5	504.71	16.90	16.09	6.18	39.17	46.00	-6.83	QP	VERTICAL
6	866.09	9.24	21.65	7.33	38.22	46.00	-7.78	QP	VERTICAL

Note: 1. Result Level = Read Level + Antenna Factor + Cable loss.
 2. If Peak Result complies with QP limit, QP Result is deemed to comply with QP limit.
 3. Test setup: RBW: 120 kHz, VBW: 300 kHz, Sweep time: auto.

Radiated Emission test (above 1GHz)

Freq (MHz)	Read level (dB μ V)	Antenna Factor (dB/m)	PRM Factor (dB)	Cable Loss (dB)	Result Level (dB μ V/m)	Limit (dB μ V/m)	Margin (dB)	Detector type	Polarization
Tx mode CH1									
3218.00	45.83	32.25	30.03	6.19	54.24	74.00	-19.76	Peak	HORIZONTAL
3218.00	40.02	32.25	30.03	6.19	48.43	54.00	-5.57	Average	HORIZONTAL
4828.50	38.41	35.42	29.32	8.09	52.60	74.00	-21.40	Peak	HORIZONTAL
4828.50	29.60	35.42	29.32	8.09	43.79	54.00	-10.21	Average	HORIZONTAL
4828.50	42.96	35.42	29.32	8.11	57.17	74.00	-16.83	Peak	VERTICAL
4828.50	34.10	35.42	29.32	8.11	48.31	54.00	-5.69	Average	VERTICAL
7238.00	35.82	37.24	30.52	9.95	52.49	74.00	-21.51	Peak	VERTICAL
7238.00	29.11	37.24	30.52	9.95	45.78	54.00	-8.22	Average	VERTICAL
Tx mode CH8									
4875.75	39.31	35.51	29.33	8.14	53.63	74.00	-20.37	Peak	HORIZONTAL
4875.75	29.39	35.51	29.33	8.14	43.71	54.00	-10.29	Average	HORIZONTAL
7324.00	33.75	37.30	30.59	9.99	50.45	74.00	-23.55	Peak	HORIZONTAL
15756.00	32.63	42.33	35.56	13.65	53.05	74.00	-20.95	Peak	HORIZONTAL
4875.75	43.55	35.51	29.33	8.14	57.87	74.00	-16.13	Peak	VERTICAL
4875.75	32.59	35.51	29.33	8.14	46.91	54.00	-7.09	Average	VERTICAL
7307.00	34.99	37.29	30.57	9.97	51.68	74.00	-22.32	Peak	VERTICAL
14039.00	34.51	40.40	34.76	13.22	53.37	74.00	-20.63	Peak	VERTICAL
Tx mode CH15									
4923.00	39.40	35.59	29.34	8.16	53.81	74.00	-20.19	Peak	HORIZONTAL
4923.00	30.40	35.59	29.34	8.16	44.81	54.00	-9.19	Average	HORIZONTAL
7375.00	35.82	37.33	30.63	10.01	52.53	74.00	-21.47	Peak	HORIZONTAL
14005.00	35.12	40.30	34.73	13.21	53.90	74.00	-20.10	Peak	HORIZONTAL
4923.00	43.20	35.59	29.34	8.16	57.61	74.00	-16.39	Peak	VERTICAL
4923.00	32.80	35.59	29.34	8.16	47.21	54.00	-6.79	Average	VERTICAL
7383.00	35.18	37.33	30.65	10.01	51.87	74.00	-22.13	Peak	VERTICAL
14039.00	34.00	40.40	34.76	13.22	52.86	74.00	-21.14	Peak	VERTICAL
Result: Pass									
Test Date : 2016/01/19					Test Engineer : Leo				

Note: Result Level = Read Level + Antenna Factor + Cable loss - PRM Factor.

11. Band Edge Compliance

11.1. Block diagram of test setup

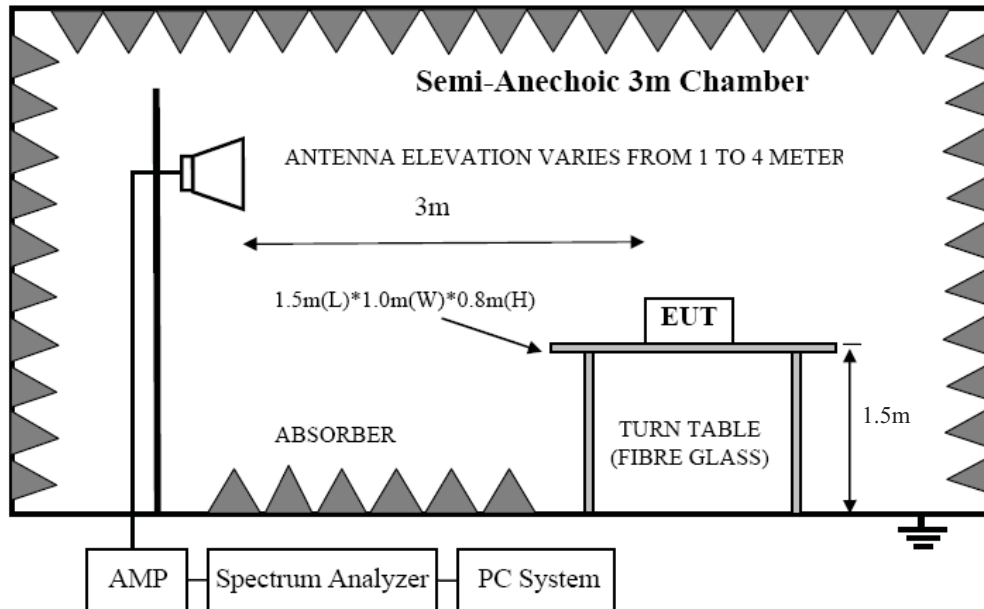

11.2. Limit

All the lower and upper band-edges emissions appearing within 2310MHz to 2390MHz and 2483.5MHz to 2500MHz restricted frequency bands shall not exceed the limits shown in 15.209, all the other emissions outside operation frequency band 2400MHz to 2483.5MHz shall be at least 20dB below the fundamental emissions, or comply with 15.209 limits.

11.3. Test Procedure

Same with clause 10.3 except change investigated frequency range from 2300MHz to 2408MHz and 2470MHz to 2500MHz.

Remark: All restriction band have been tested, and only the worse case is shown in report.

11.4. Test result

PASS. (See below detailed test result)

Remark: Hopping on and hopping off mode all have been test, hopping off mode is worse and reported only.

TR-4-E-009 Radiated Emission Test Result

Test Site	: DDT 3m Chamber	E:\2016 Report Data\16Q0105-5\RE.EM6
Test Date	: 2016-01-20	Tested By : Toby
EUT	: Digital Wireless Weather Proof Camera	Model Number : AWSC35
Power Supply	: DC 5V from adapter	Test Mode : TX 2414.25MHz
Condition	: Temp:24.5°C,Humi:55%, Press:100.1kPa	Antenna/Distance : 2014 HF907/3m/VERTICAL
Memo	: Adapter:I.T.E	

Data: 15

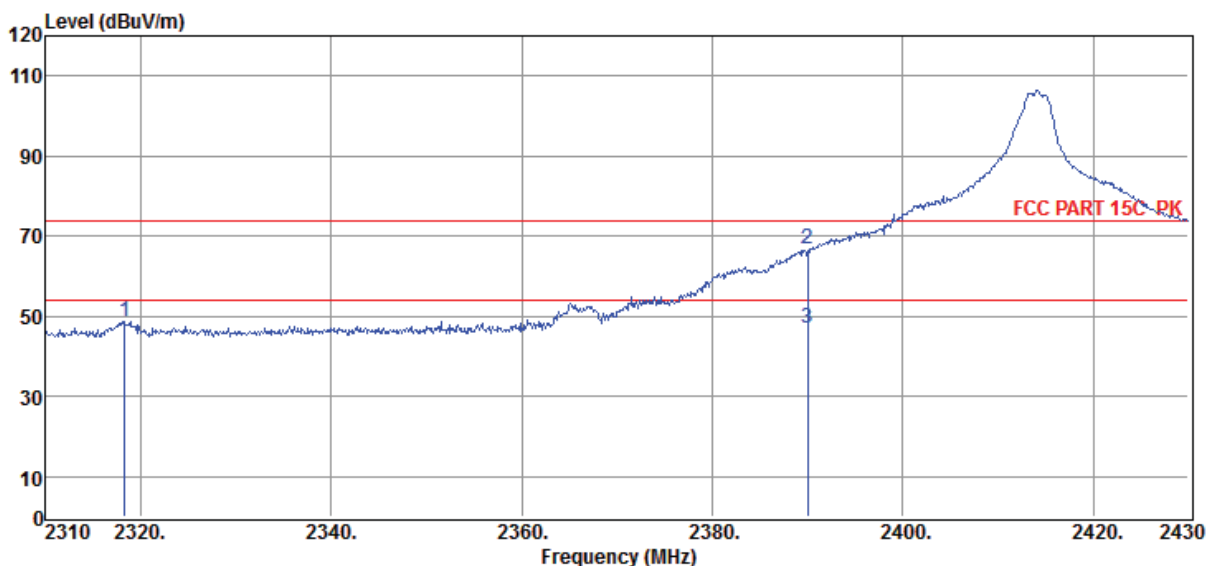

Item (Mark)	Freq (MHz)	Read Level (dBμV)	Antenna Factor (dB/m)	PRM Factor dB	Cable Loss dB	Result Level (dBμV/m)	Limit Line (dBμV/m)	Over Limit (dB)	Detector	Polarization
1	2318.28	43.02	29.78	29.29	5.06	48.57	74.00	-25.43	Peak	VERTICAL
2	2390.00	60.96	29.99	29.41	5.17	66.71	74.00	-7.29	Peak	VERTICAL
3	2390.00	41.10	29.99	29.41	5.17	46.85	54.00	-7.15	Average	VERTICAL

Note: 1. Result Level = Read Level + Antenna Factor + Cable loss - PRM Factor.
 2. If Peak Result complies with AV limit, AV Result is deemed to comply with AV limit.
 3. Test setup: RBW: 1 MHz, VBW: 3 MHz, Sweep time: auto.

TR-4-E-009 Radiated Emission Test Result

Test Site	: DDT 3m Chamber	E:\2016 Report Data\16Q0105-5\RE.EM6
Test Date	: 2016-01-20	Tested By : Toby
EUT	: Digital Wireless Weather Proof Camera	Model Number : AWSC35
Power Supply	: DC 5V from adapter	Test Mode : TX 2414.25MHz
Condition	: Temp:24.5°C,Humi:55%, Press:100.1kPa	Antenna/Distance : 2014 HF907/3m/HORIZONTAL
Memo	: Adapter:I.T.E	

Data: 16

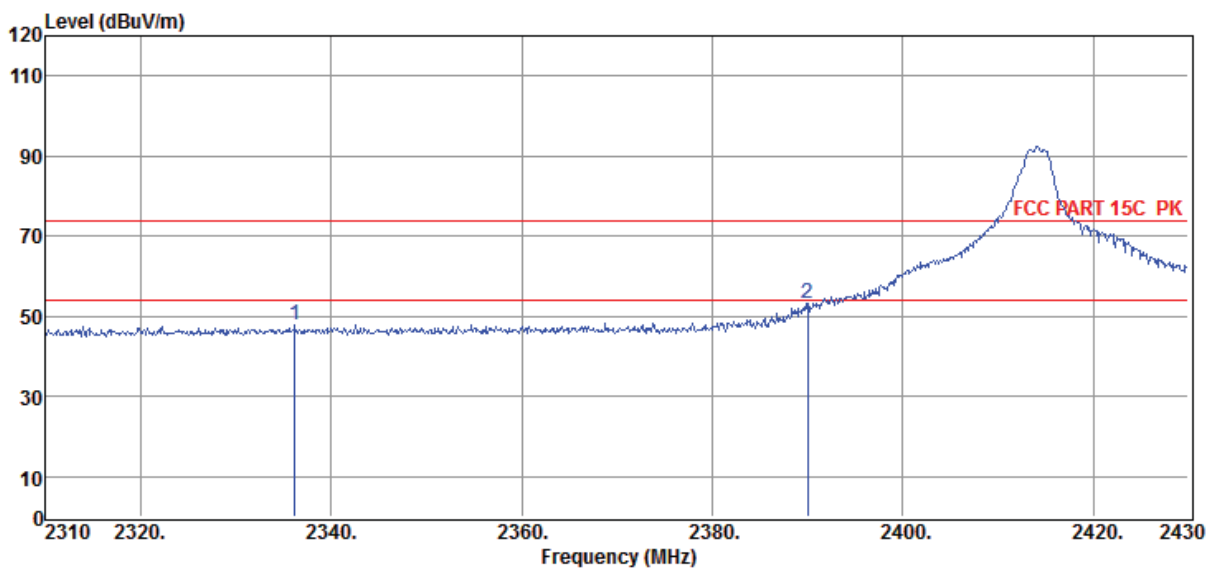

Item (Mark)	Freq (MHz)	Read Level (dBμV)	Antenna Factor (dB/m)	PRM Factor dB	Cable Loss dB	Result Level (dBμV/m)	Limit Line (dBμV/m)	Over Limit (dB)	Detector	Polarization
1	2336.16	42.33	29.83	29.32	5.06	47.90	74.00	-26.10	Peak	HORIZONTAL
2	2390.00	47.33	29.99	29.41	5.17	53.08	74.00	-20.92	Peak	HORIZONTAL

- Note: 1. Result Level = Read Level + Antenna Factor + Cable loss - PRM Factor.
 2. If Peak Result complies with AV limit, AV Result is deemed to comply with AV limit.
 3. Test setup: RBW: 1 MHz, VBW: 3 MHz, Sweep time: auto.

TR-4-E-009 Radiated Emission Test Result

Test Site	: DDT 3m Chamber	E:\2016 Report Data\16Q0105-5\RE.EM6
Test Date	: 2016-01-20	Tested By : Toby
EUT	: Digital Wireless Weather Proof Camera	Model Number : AWSC35
Power Supply	: DC 5V from adapter	Test Mode : TX 2461.50MHz
Condition	: Temp:24.5°C,Humi:55%, Press:100.1kPa	Antenna/Distance : 2014 HF907/3m/VERTICAL
Memo	: Adapter:I.T.E	

Data: 17

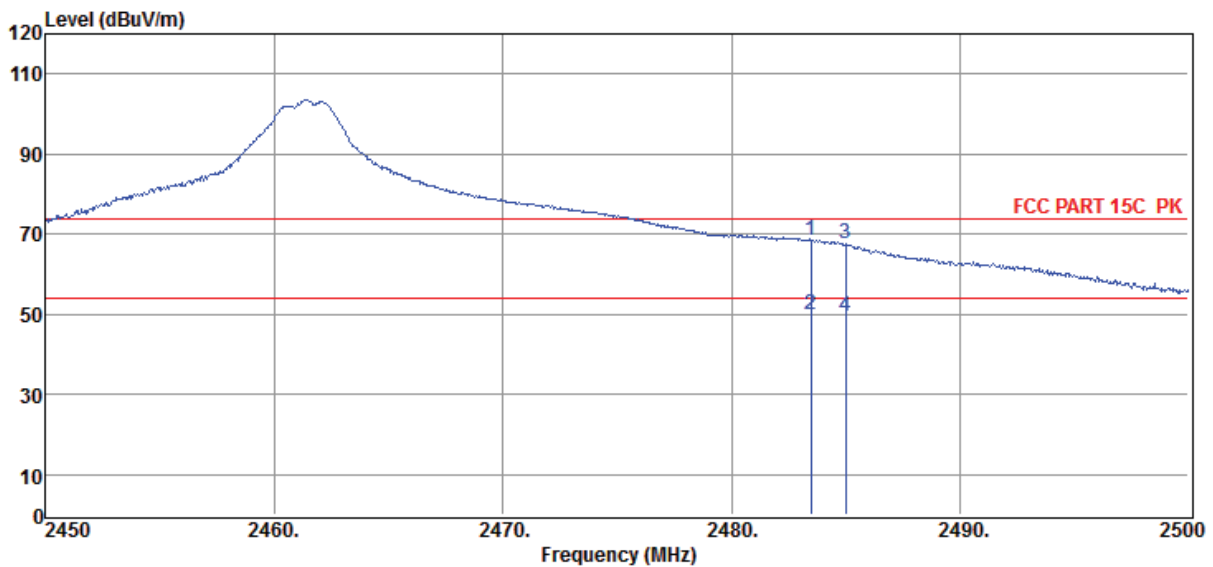

Item (Mark)	Freq (MHz)	Read Level (dBμV)	Antenna Factor (dB/m)	PRM Factor dB	Cable Loss dB	Result Level (dBμV/m)	Limit Line (dBμV/m)	Over Limit (dB)	Detector	Polarization
1	2483.50	62.62	30.25	29.71	5.31	68.47	74.00	-5.53	Peak	VERTICAL
2	2483.50	44.10	30.25	29.71	5.31	49.95	54.00	-4.05	Average	VERTICAL
3	2485.00	61.60	30.25	29.71	5.31	67.45	74.00	-6.55	Peak	VERTICAL
4	2485.00	43.50	30.25	29.71	5.31	49.35	54.00	-4.65	Average	VERTICAL

Note: 1. Result Level = Read Level + Antenna Factor + Cable loss - PRM Factor.
 2. If Peak Result complies with AV limit, AV Result is deemed to comply with AV limit.
 3. Test setup: RBW: 1 MHz, VBW: 3 MHz, Sweep time: auto.

TR-4-E-009 Radiated Emission Test Result

Test Site	: DDT 3m Chamber	E:\2016 Report Data\16Q0105-5\RE.EM6
Test Date	: 2016-01-20	Tested By : Toby
EUT	: Digital Wireless Weather Proof Camera	Model Number : AWSC35
Power Supply	: DC 5V from adapter	Test Mode : TX 2461.50MHz
Condition	: Temp:24.5°C,Humi:55%, Press:100.1kPa	Antenna/Distance : 2014 HF907/3m/HORIZONTAL
Memo	: Adapter:I.T.E	

Data: 18

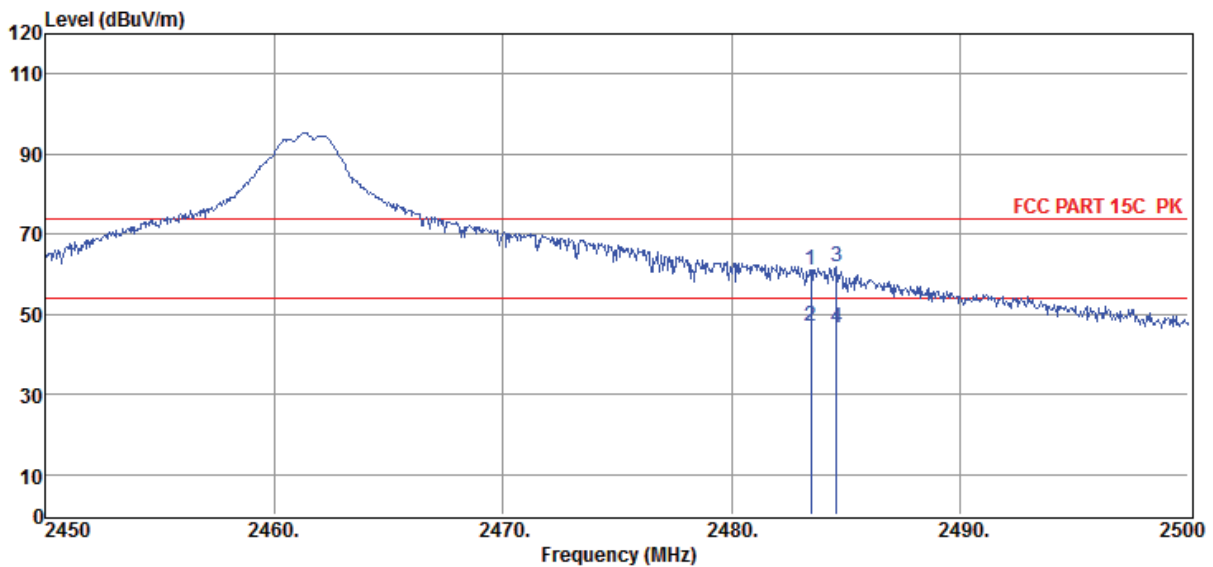

Item (Mark)	Freq (MHz)	Read Level (dBμV)	Antenna Factor (dB/m)	PRM Factor dB	Cable Loss dB	Result Level (dBμV/m)	Limit Line (dBμV/m)	Over Limit (dB)	Detector	Polarization
1	2483.50	55.28	30.25	29.71	5.31	61.13	74.00	-12.87	Peak	HORIZONTAL
2	2483.50	41.10	30.25	29.71	5.31	46.95	54.00	-7.05	Average	HORIZONTAL
3	2484.60	55.84	30.25	29.71	5.31	61.69	74.00	-12.31	Peak	HORIZONTAL
4	2484.60	40.60	30.25	29.71	5.31	46.45	54.00	-7.55	Average	HORIZONTAL

Note: 1. Result Level = Read Level + Antenna Factor + Cable loss - PRM Factor.
 2. If Peak Result complies with AV limit, AV Result is deemed to comply with AV limit.
 3. Test setup: RBW: 1 MHz, VBW: 3 MHz, Sweep time: auto.

12. Power Line Conducted Emission

12.1. Block diagram of test setup

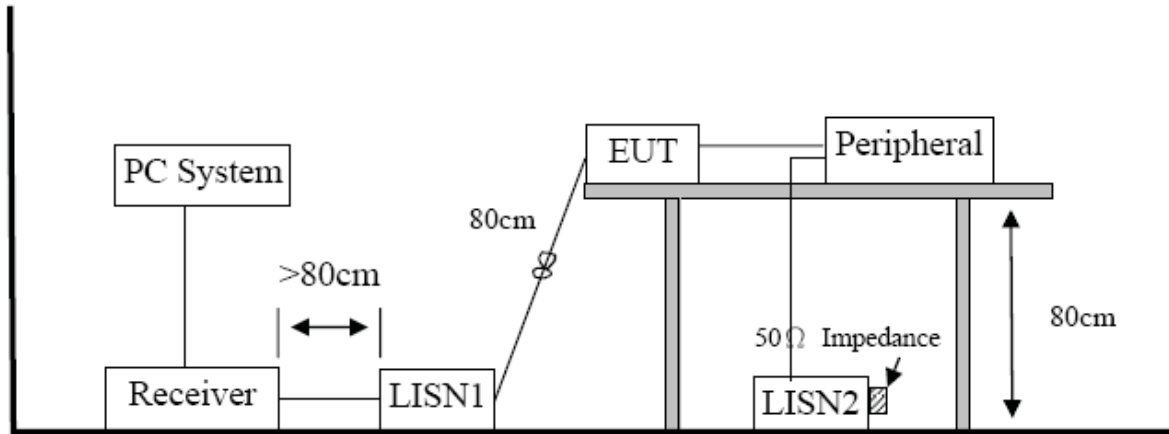

12.2. Power Line Conducted Emission Limits(Class B)

Frequency	Quasi-Peak Level dB(μ V)	Average Level dB(μ V)
150kHz ~ 500kHz	66 ~ 56*	56 ~ 46*
500kHz ~ 5MHz	56	46
5MHz ~ 30MHz	60	50

Note 1: * Decreasing linearly with logarithm of frequency.

Note 2: The lower limit shall apply at the transition frequencies.

12.3. Test Procedure

The EUT and Support equipment, if needed, were put placed on a non-metallic table, 80cm above the ground plane.

Configuration EUT to simulate typical usage as described in clause 2.4 and test equipment as described in clause 10.2 of this report.

All I/O cables were positioned to simulate typical actual usage as per ANSI C63.4.

All support equipment power received from a second LISN.

Emissions were measured on each current carrying line of the EUT using an EMI Test Receiver connected to the LISN powering the EUT.

The Receiver scanned from 150 kHz to 30MHz for emissions in each of the test modes.

During the above scans, the emissions were maximized by cable manipulation.

The test mode(s) described in clause 2.4 were scanned during the preliminary test.

After the preliminary scan, we found the test mode producing the highest emission level.

The EUT configuration and worse cable configuration of the above highest emission levels were recorded for reference of the final test.

EUT and support equipment were set up on the test bench as per the configuration with highest emission level in the preliminary test.

A scan was taken on both power lines, Neutral and Line, recording at least the six highest emissions.

Emission frequency and amplitude were recorded into a computer in which correction factors were used to calculate the emission level and compare reading to the applicable limit.

The test data of the worst-case condition(s) was recorded.

The bandwidth of test receiver is set at 9 KHz.

12.4. Test Result

PASS. (See below detailed test result)

Note1: All emissions not reported below are too low against the prescribed limits.

Note2: “----” means Peak detection; “-----” mans Average detection

TR-4-E-010 Conducted Emission Test Result

Test Site : DDT 1# Shield Room E:\2016 report data\16Q0105-5\CE.EM6
Test Date : 2016-01-16 **Tested By** : Toby
EUT : Digital Wireless Weather Proof Camera **Model Number** : AWSC35
Power Supply : DC 5V from adapter **Test Mode** : TX Mode
Condition : Temp:24.5°C,Humi:55%,
LISN : 2014 ENV216/NEUTRAL
Press:100.1kPa
Memo : Adapter:Csec

Data: 10

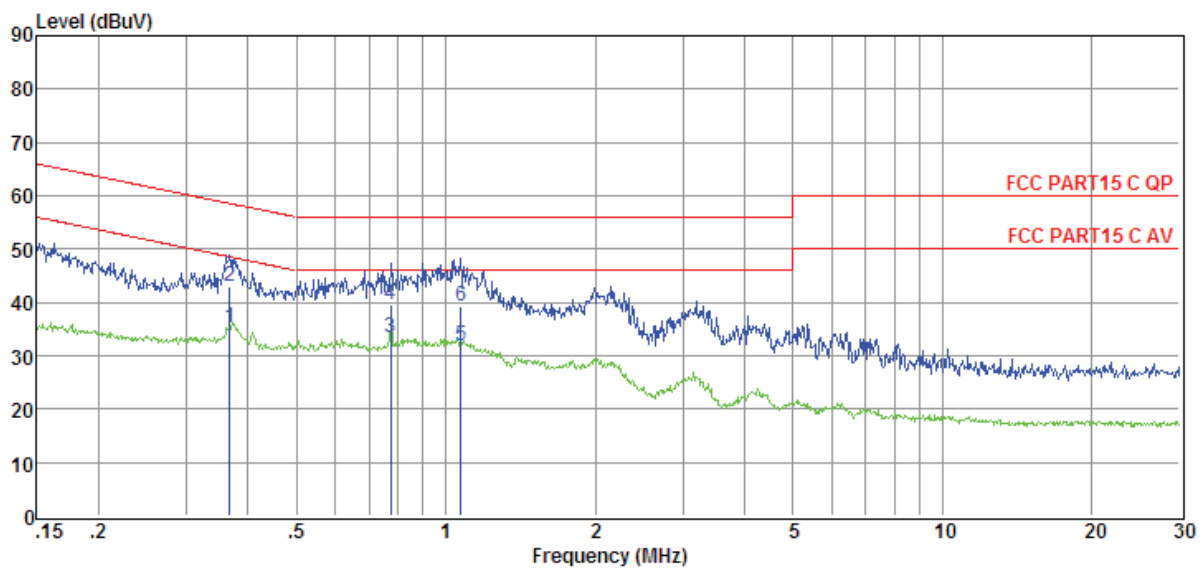

Item	Freq	Read Level	LISN Factor	Cable Loss	Pulse Limiter Factor	Result Level	Limit Line	Over Limit	Detector	Phase
(Mark)	(MHz)	(dBμV)	(dB)	(dB)	(dB)	(dBμV)	(dBμV)	(dB)		
1	0.37	15.71	9.60	0.02	9.86	35.19	48.56	-13.37	Average	NEUTRAL
2	0.37	23.50	9.60	0.02	9.86	42.98	58.56	-15.58	QP	NEUTRAL
3	0.78	14.01	9.61	0.08	9.86	33.56	46.00	-12.44	Average	NEUTRAL
4	0.78	19.99	9.61	0.08	9.86	39.54	56.00	-16.46	QP	NEUTRAL
5	1.07	12.20	9.60	0.04	9.87	31.71	46.00	-14.29	Average	NEUTRAL
6	1.07	19.75	9.60	0.04	9.87	39.26	56.00	-16.74	QP	NEUTRAL

- Note: 1. Result Level = Read Level + LISN Factor + Pulse Limiter Factor + Cable loss.
 2. If QP Result complies with AV limit, AV Result is deemed to comply with AV limit.
 3. Test setup: RBW: 200 Hz (9 kHz—150 kHz), 9 kHz (150 kHz—30 MHz).
 4. Step size: 80Hz (0.009MHz-0.15MHz), 4 kHz (0.15MHz-30MHz), Scan time: auto.

TR-4-E-010 Conducted Emission Test Result

Test Site	: DDT 1# Shield Room	E:\2016 report data\16Q0105-5\CE.EM6
Test Date	: 2016-01-16	Tested By : Toby
EUT	: Digital Wireless Weather Proof Camera	Model Number : AWSC35
Power Supply	: DC 5V from adapter	Test Mode : TX Mode
Condition	: Temp:24.5°C,Humi:55%, Press:100.1kPa	LISN : 2014 ENV216/LINE
Memo	: Adapter:Csec	

Data: 12

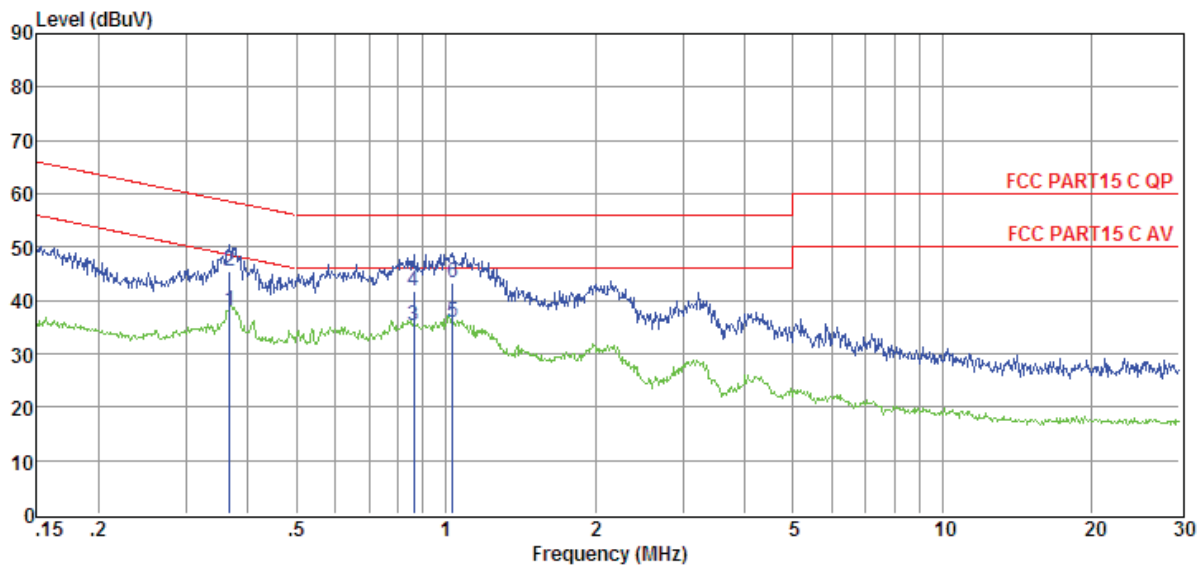

Item	Freq	Read Level	LISN Factor	Cable Loss	Pulse Limiter Factor	Result Level	Limit Line	Over Limit	Detector	Phase
(Mark)	(MHz)	(dBμV)	(dB)	(dB)	(dB)	(dBμV)	(dBμV)	(dB)		
1	0.37	18.56	9.63	0.02	9.86	38.07	48.56	-10.49	Average	LINE
2	0.37	25.84	9.63	0.02	9.86	45.35	58.56	-13.21	QP	LINE
3	0.86	15.59	9.62	0.07	9.86	35.14	46.00	-10.86	Average	LINE
4	0.86	22.28	9.62	0.07	9.86	41.83	56.00	-14.17	QP	LINE
5	1.03	16.37	9.62	0.04	9.87	35.90	46.00	-10.10	Average	LINE
6	1.03	23.83	9.62	0.04	9.87	43.36	56.00	-12.64	QP	LINE

- Note: 1. Result Level = Read Level + LISN Factor + Pulse Limiter Factor + Cable loss.
 2. If QP Result complies with AV limit, AV Result is deemed to comply with AV limit.
 3. Test setup: RBW: 200 Hz (9 kHz—150 kHz), 9 kHz (150 kHz—30 MHz).
 4. Step size: 80Hz (0.009MHz-0.15MHz), 4 kHz (0.15MHz-30MHz), Scan time: auto.

13. Antenna Requirements

13.1. Limit

For intentional device, according to FCC 47 CFR Section 15.203, an intentional radiator shall be designed to ensure that no antenna other than that furnished by the responsible party shall be used with the device. And according to FCC 47 CFR Section 15.247 (b), if transmitting antennas of directional gain greater than 6dBi are used, the power shall be reduced by the amount in dB that the directional gain of the antenna exceeds 6dBi.

13.2. Result

The antennas used for this product are Rod antenna and that no antenna other than that furnished by the responsible party shall be used with the device, the maximum peak gain of the transmit antenna is 2.0dBi.

14. Test setup photograph

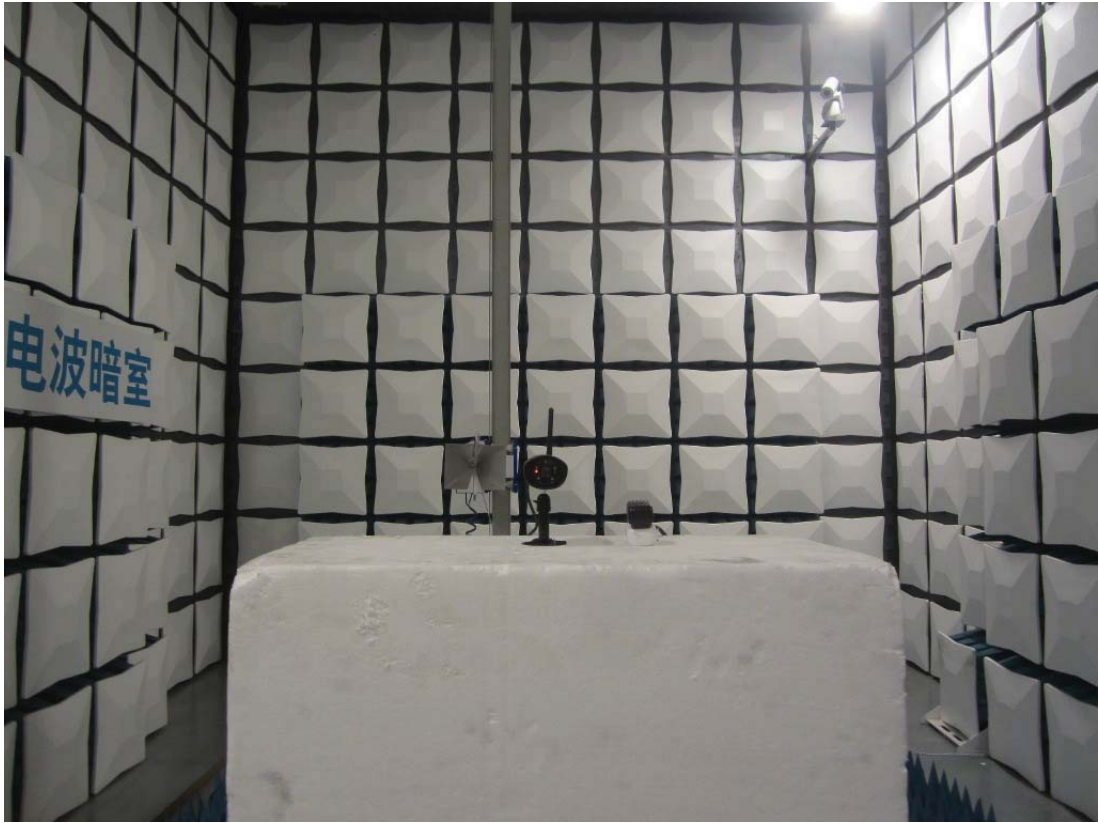
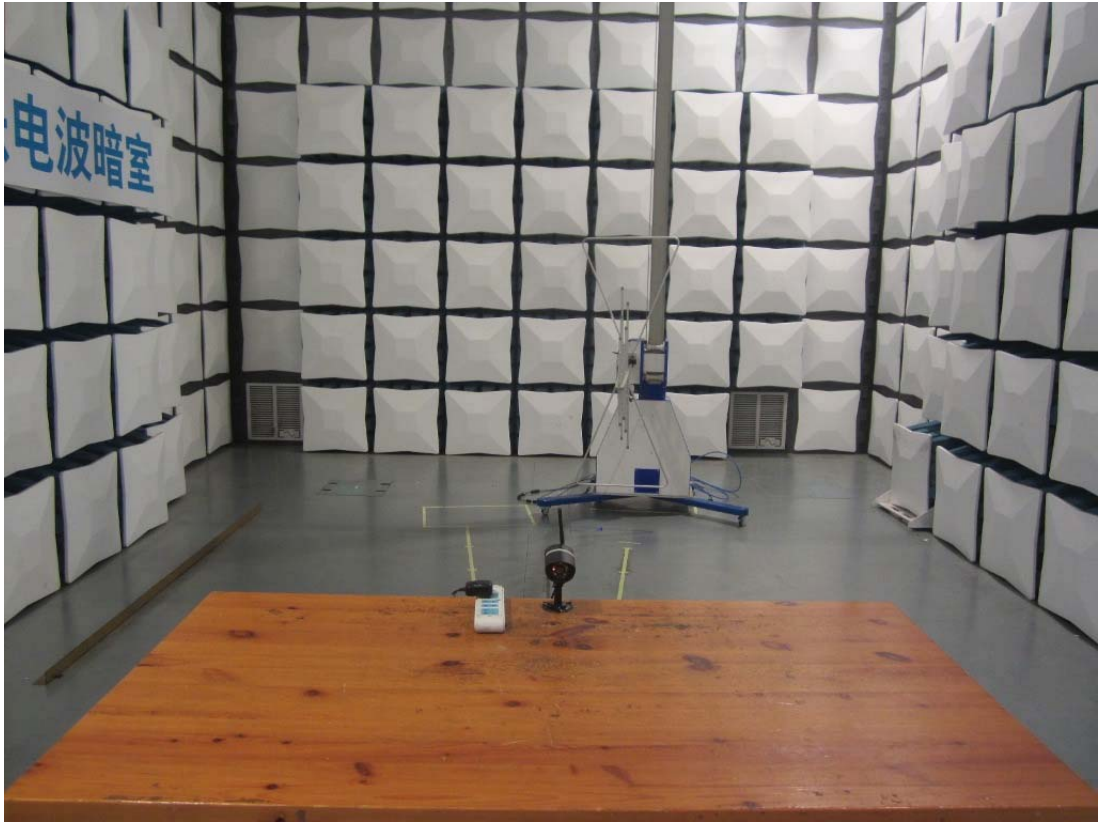



15. Photos of the EUT











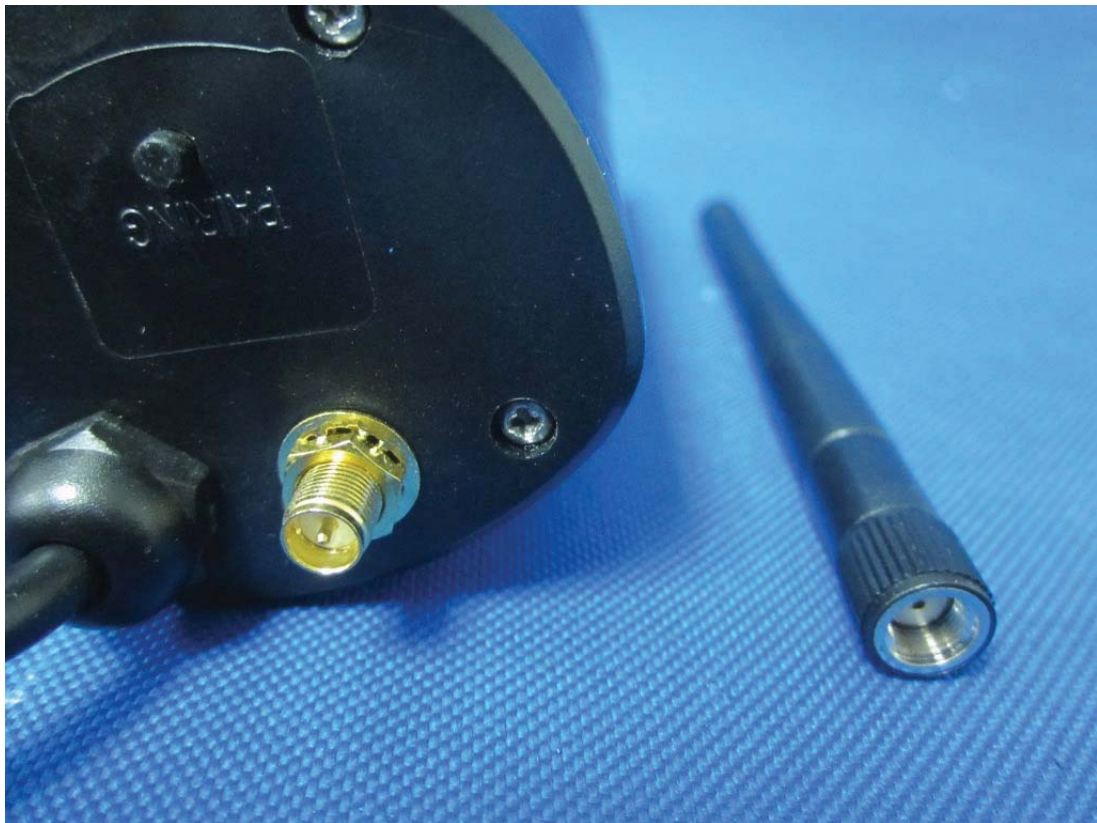

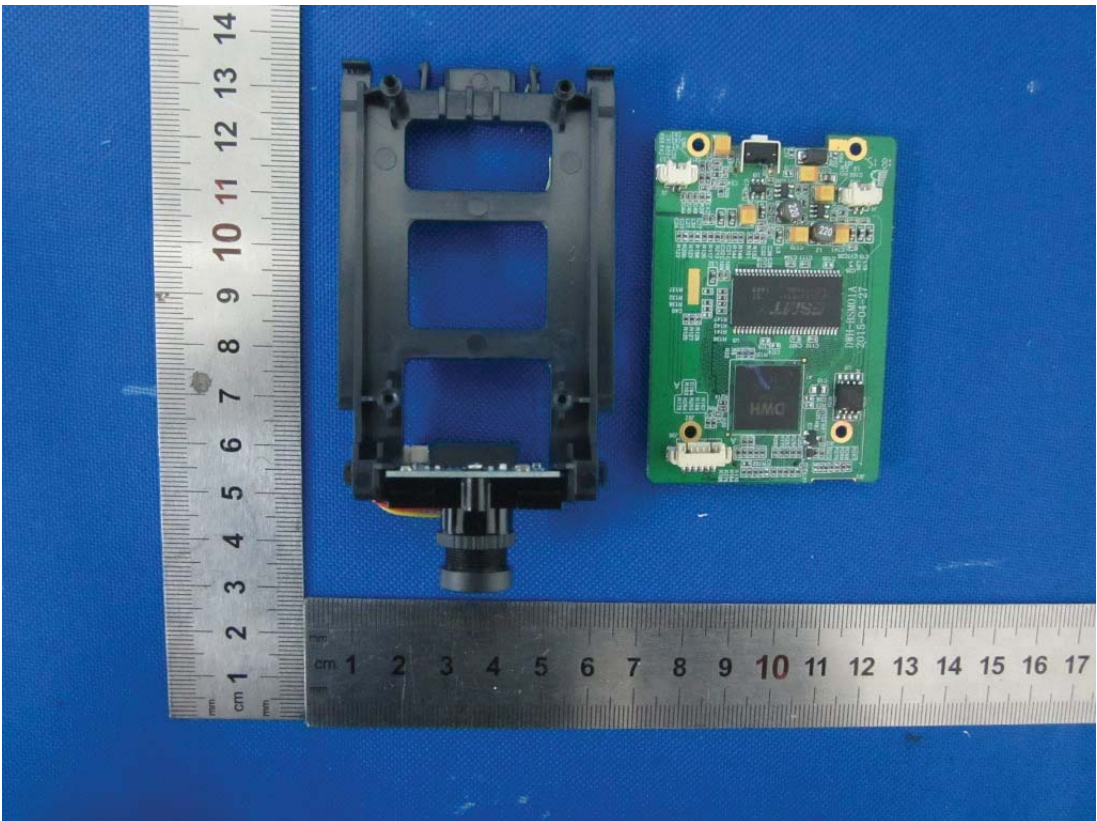

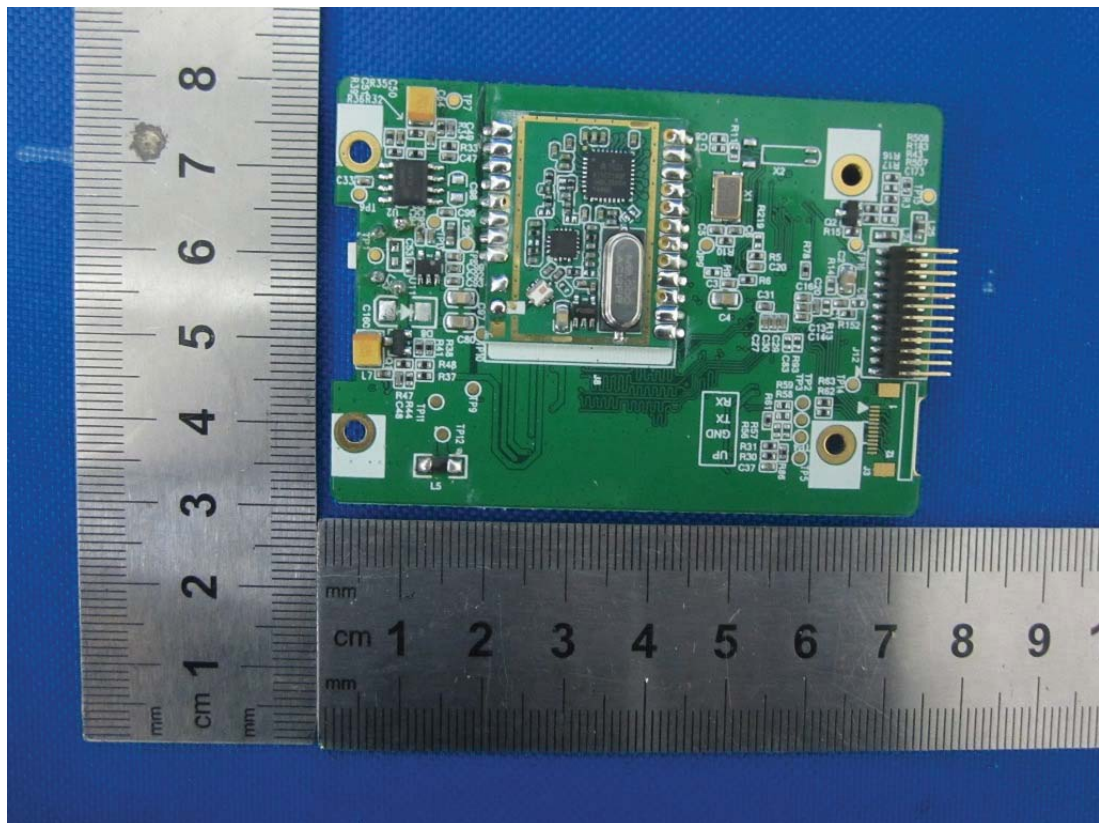
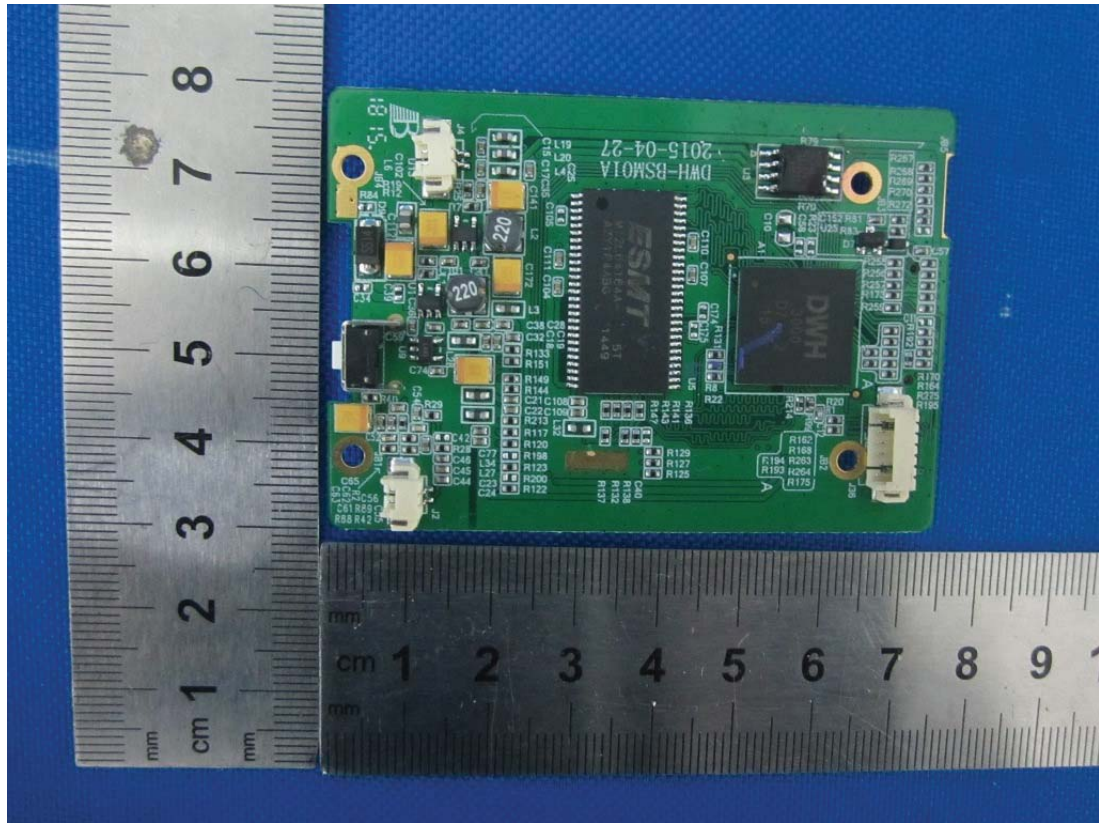

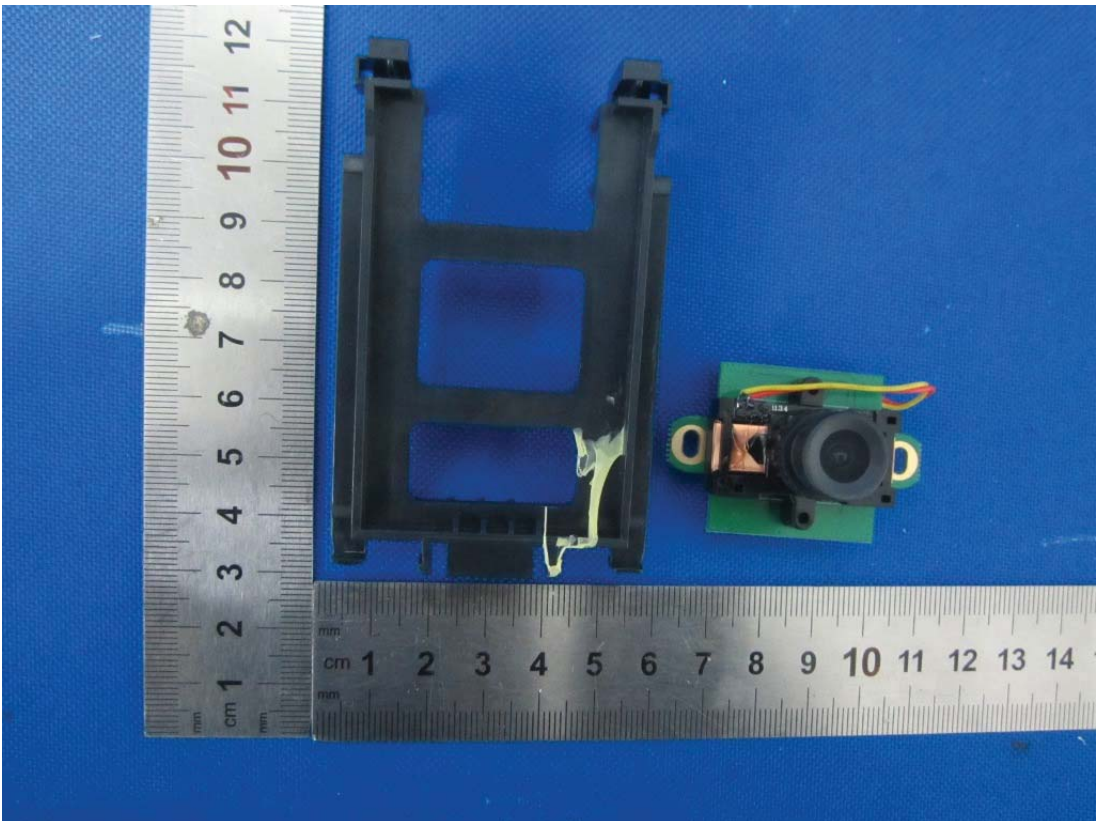
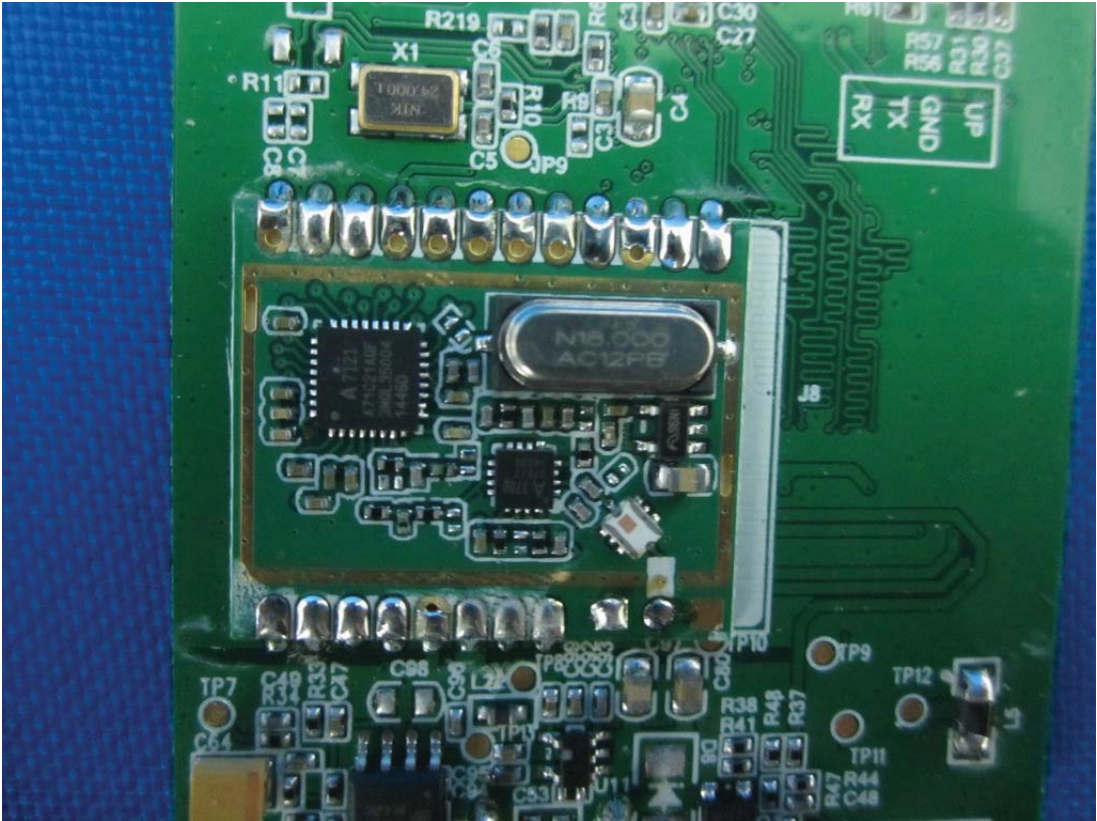

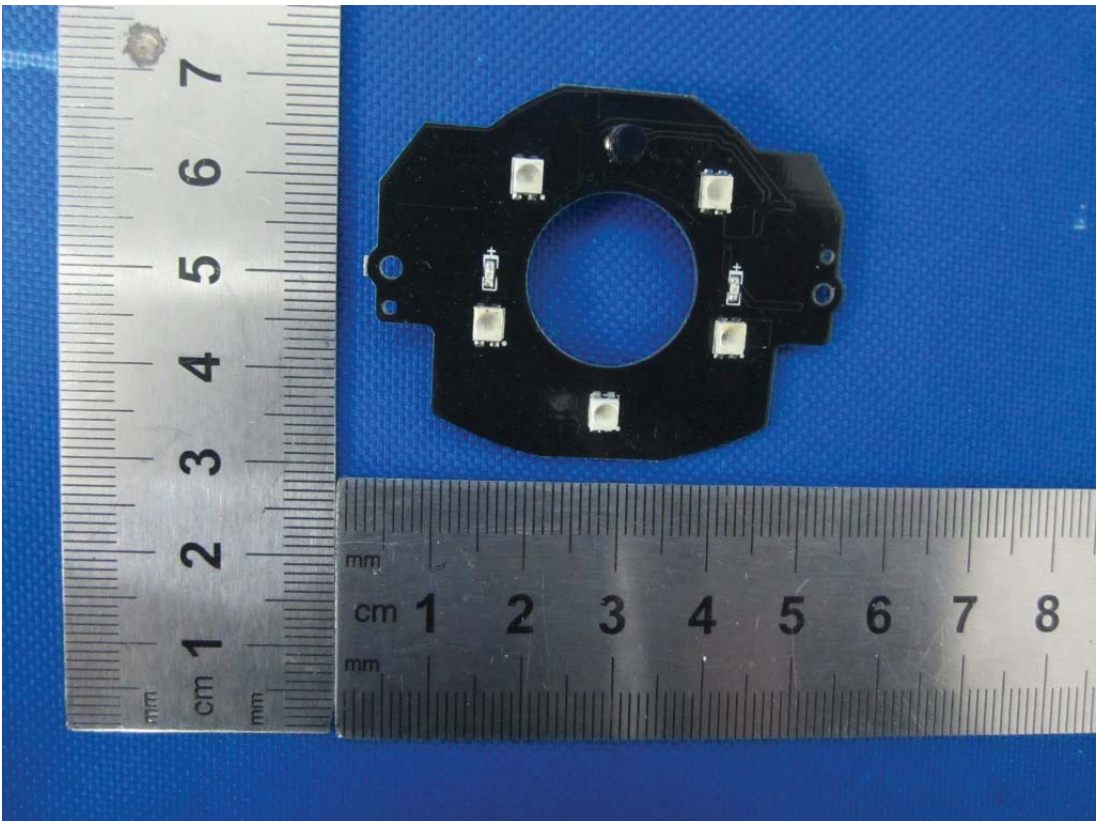
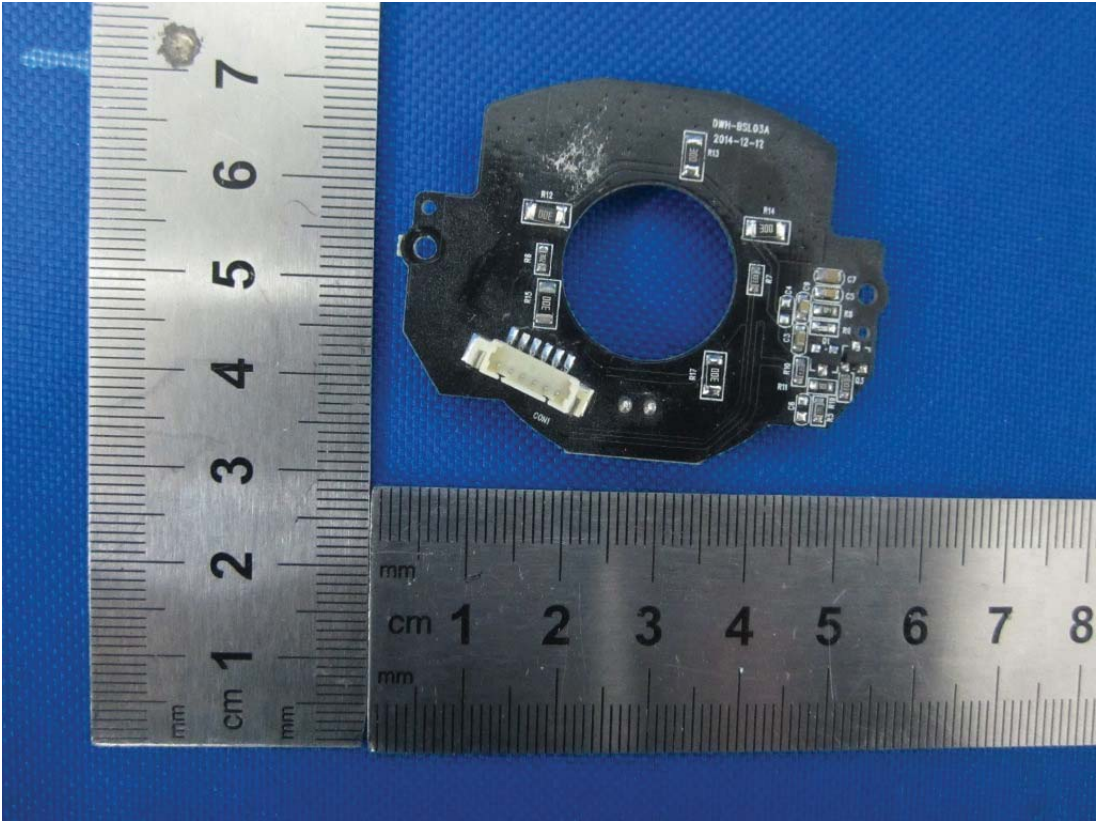

END OF REPORT