

CETECOM™

CETECOM ICT Services
consulting - testing - certification >>>

TEST REPORT

Test report no.: 1-9611/15-01-11



Deutsche
Akkreditierungsstelle
D-PL-12076-01-00

Testing laboratory

CETECOM ICT Services GmbH
Untertuerkheimer Strasse 6 – 10
66117 Saarbruecken / Germany
Phone: + 49 681 5 98 - 0
Fax: + 49 681 5 98 - 9075
Internet: <http://www.cetecom.com>
e-mail: ict@cetecom.com

Accredited Testing Laboratory:

The testing laboratory (area of testing) is accredited according to DIN EN ISO/IEC 17025 (2005) by the Deutsche Akkreditierungsstelle GmbH (DAkkS). The accreditation is valid for the scope of testing procedures as stated in the accreditation certificate with the registration number: D-PL-12076-01-00

Applicant

Bowers & Wilkins
Dale Rd, Worthing,
West Sussex BN11 2BH / UNITED KINGDOM
Phone: -/
Fax: -/
Contact: -/
e-mail: -/
Phone: -/

Manufacturer

Bowers & Wilkins
Dale Rd, Worthing,
West Sussex BN11 2BH / UNITED KINGDOM

Test standard/s

47 CFR Part 15 Title 47 of the Code of Federal Regulations; Chapter I; Part 15 - Radio frequency devices

For further applied test standards please refer to section 3 of this test report.

Test Item

Kind of test item: Wireless music system
Model name: Zeppelin Wireless
FCC ID: 2ACIX-ZW
IC: 11946B-ZW
Frequency: 5150 MHz to 5350 MHz & 5470 MHz to 5725 MHz
Technology tested: WLAN (only DFS)
Antenna: Integrated antenna
Power supply: 230 V AC
Temperature range: +5°C to +35°C



This test report is electronically signed and valid without handwriting signature. For verification of the electronic signatures, the public keys can be requested at the testing laboratory.

Test report authorised:

Stefan BöS
Lab Manager
Radio Communications & EMC

Test performed:

David Lang
Lab Manager
Radio Communications & EMC

1 Table of contents

1 Table of contents2

2 General information3

 2.1 Notes and disclaimer3

 2.2 Application details3

3 Test standard/s3

 3.1 Measurement guidance3

4 Test environment4

5 Test item4

 5.1 Additional information4

6 Test laboratories sub-contracted4

7 Summary of measurement results5

8 RF measurements6

 8.1 Description of test setup6

 8.1.1 Conducted measurements6

 8.1.2 Parameters of DFS test signals7

 8.2 DFS test results8

 8.2.1 Channel move time / channel closing transmission time8

 8.2.2 Non-Occupancy Period10

9 Observations11

Annex A Document history11

Annex B Further information11

Annex C Accreditation Certificate12

2 General information

2.1 Notes and disclaimer

The test results of this test report relate exclusively to the test item specified in this test report. CETECOM ICT Services GmbH does not assume responsibility for any conclusions and generalizations drawn from the test results with regard to other specimens or samples of the type of the equipment represented by the test item.

The test report may only be reproduced or published in full. Reproduction or publication of extracts from the report requires the prior written approval of CETECOM ICT Services GmbH.

The testing service provided by CETECOM ICT Services GmbH has been rendered under the current "General Terms and Conditions for CETECOM ICT Services GmbH".

CETECOM ICT Services GmbH will not be liable for any loss or damage resulting from false, inaccurate, inappropriate or incomplete product information provided by the customer.

Under no circumstances does the CETECOM ICT Services GmbH test report include any endorsement or warranty regarding the functionality, quality or performance of any other product or service provided.

Under no circumstances does the CETECOM ICT Services GmbH test report include or imply any product or service warranties from CETECOM ICT Services GmbH, including, without limitation, any implied warranties of merchantability, fitness for purpose, or non-infringement, all of which are expressly disclaimed by CETECOM ICT Services GmbH.

All rights and remedies regarding vendor's products and services for which CETECOM ICT Services GmbH has prepared this test report shall be provided by the party offering such products or services and not by CETECOM ICT Services GmbH.

In no case this test report can be considered as a Letter of Approval.

This test report is electronically signed and valid without handwritten signature. For verification of the electronic signatures, the public keys can be requested at the testing laboratory.

2.2 Application details

Date of receipt of order:	2015-04-22
Date of receipt of test item:	2015-06-05
Start of test:	2015-06-15
End of test:	2015-07-07
Person(s) present during the test:	-/-

3 Test standard/s

Test standard	Date	Test standard description
47 CFR Part 15		Title 47 of the Code of Federal Regulations; Chapter I; Part 15 - Radio frequency devices

3.1 Measurement guidance

UNII: KDB 905462	2015-05	DFS Compliance Procedures New Rules v01r02
------------------	---------	--

4 Test environment

Temperature:	T_{nom}	+22 °C during room temperature tests
	T_{max}	+35 °C during high temperature tests
	T_{min}	+5 °C during low temperature tests
Relative humidity content:		51 %
Barometric pressure:		not relevant for this kind of testing
Power supply:	V_{nom}	230 V AC
	V_{max}	240 V
	V_{min}	100 V

5 Test item

Kind of test item	:	Wireless music system
Type identification	:	Zeppelin Wireless
HMN	:	-/-
PMN	:	Zeppelin Wireless
HVIN	:	Zeppelin Wireless
FVIN	:	MCU 1.00, WiFi CP15, BT 1.1
S/N serial number	:	1503-TR110095
HW hardware status	:	TR1
SW software status	:	ir-fsccp-scb-FS2026-0500-0204.2.8CP.15pre8.STANDARD(624).sap
Frequency band	:	5150 MHz to 5350 MHz & 5470 MHz to 5725 MHz
Type of radio transmission	:	OFDM
Use of frequency spectrum	:	
Type of modulation	:	BPSK, QPSK, 16 – QAM, 64 – QAM
Antenna	:	Integrated antenna
Power supply	:	230 V AC
Temperature range	:	+5°C to +35°C

5.1 Additional information

The content of the following annexes is defined in the QA. It may be that not all of the listed annexes are necessary for this report, thus some values in between may be missing.

EUT-photos are included in test report: 1-9611/15-01-01_AnnexA
1-9611/15-01-01_AnnexB

6 Test laboratories sub-contracted

None

7 Summary of measurement results

<input type="checkbox"/>	No deviations from the technical specifications were ascertained
<input type="checkbox"/>	There were deviations from the technical specifications ascertained
<input checked="" type="checkbox"/>	This test report is only a partial test report. The content and verdict of the performed test cases are listed below.

TC Identifier	Description	Verdict	Date	Remark
DFS-Testing	CFR Part 15	See table below!	2015-07-10	DFS tests only

Test Report Clause	Test Case	Temperature / Voltage	Pass	Fail	NA	NP	Remark
§15.407 (h)(2) (iii)	Channel move time and channel closing transmission time	nominal / nominal	<input checked="" type="checkbox"/>	<input type="checkbox"/>	<input type="checkbox"/>	<input type="checkbox"/>	complies
§15.407 (h)(2) (iv)	Non-Occupancy Period	nominal / nominal	<input checked="" type="checkbox"/>	<input type="checkbox"/>	<input type="checkbox"/>	<input type="checkbox"/>	complies

Note: NA = Not Applicable; NP = Not Performed

8 RF measurements

8.1 Description of test setup

8.1.1 Conducted measurements

Setup

Figure 1 shows a setup whereby the UUT is a RLAN device operating in slave mode, without Radar Interference Detection function. This setup also contains a RLAN device operating in master mode. The radar test signals are injected into the master device. The UUT (slave device) is associated with the master device.

Figure 1 shows an example

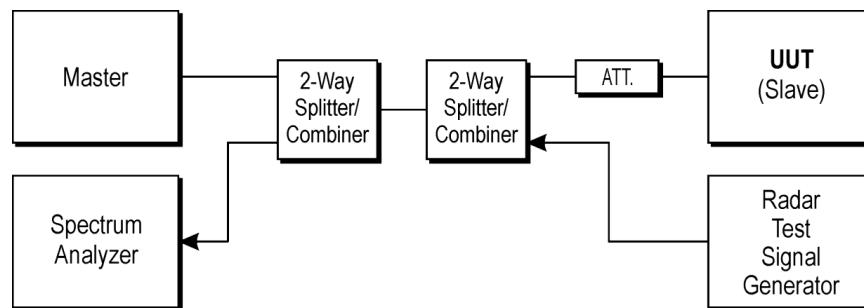

Figure 1: Setup

Typically, the calibrations of the test apparatus are commissioned to and performed by an accredited calibration laboratory. The calibration intervals are determined in accordance with the DIN EN ISO/IEC 17025. In addition to the external calibrations, the laboratory executes comparison measurements with other calibrated test systems or effective verifications. Weekly chamber inspections and range calibrations are performed. Where possible, rf-generating and signalling equipment as well as measuring receivers and analyzers are connected to an external high-precision 10 MHz reference (GPS-based or rubidium frequency standard).

In order to simplify the identification of the equipment used at some special tests, some items of test equipment and ancillaries can be provided with an identifier or number in the equipment list below (Lab/Item).

No.	Lab / Item	Equipment	Type	Manufact.	Serial No.	INV. No Cetecom	Kind of Calibration	Last Calibration	Next Calibration
1	n. a.	Vektor Signal Generator	SMU200A	R&S	101633	300003496	k	07.04.2014	07.04.2017
2	n. a.	Signal Analyzer 40 GHz	FSV40	R&S	101353	300004819	k	27.01.2015	27.01.2016
3	n. a.	DFS-test site	div. Splitter, Cables, Attenuators	Mini-Circuits	na	300004557	ev		
4	n. a.	Access point WLAN	CAP3702E-A-K9	Cisco Systems	SFTX1824R16T	300004822	ne		

Agenda: Kind of Calibration

k	calibration / calibrated	EK	limited calibration
ne	not required (k, ev, izw, zw not required)	zw	cyclical maintenance (external cyclical maintenance)
ev	periodic self verification	izw	internal cyclical maintenance
Ve	long-term stability recognized	g	blocked for accredited testing
vk!	Attention: extended calibration interval	*)	next calibration ordered / currently in progress
NK!	Attention: not calibrated		

8.1.2 Parameters of DFS test signals

1. Interference Threshold values, Master or Client incorporating In-Service Monitoring

Maximum Transmit Power	Value (see note)
≥ 200 mW	-64 dBm
< 200 mW	-62 dBm
<p>Note 1: This is the level at the input of the receiver assuming a 0 dBi receive antenna Note 2: Throughout these test procedures an additional 1 dB has been added to the amplitude of the test transmission waveforms to account for variations in measurement equipment. This will ensure that the test signal is at or above the detection threshold level to trigger a DFS response.</p>	

2. DFS Response requirement values

Parameter	Value
Non-occupancy period	minimum 30 minutes
Channel Availability Check Time	60 seconds
Channel Move Time	10 seconds See Note 1.
Channel Closing Transmission Time	200 milliseconds + an aggregate of 60 milliseconds over remaining 10 second period. See Notes 1 and 2.
U-NII Detection Bandwidth	Minimum 80% of the 99% transmission power bandwidth See Note 3.
<p>Note 1: The instant that the Channel Move Time and the Channel Closing Transmission Time begins is as follows:</p> <ul style="list-style-type: none"> • For the Short pulse radar Test Signals this instant is the end of the Burst. • For the Frequency Hopping radar Test Signal, this instant is the end of the last radar Burst generated. • For the Long Pulse radar Test Signal this instant is the end of the 12 second period defining the radar transmission. <p>Note 2: The Channel Closing Transmission Time is comprised of 200 milliseconds starting at the beginning of the Channel Move Time plus any additional intermittent control signals required to facilitate Channel changes (an aggregate of 60 milliseconds) during the remainder of the 10 second period. The aggregate duration of control signals will not count quiet periods in between transmissions.</p> <p>Note 3: During the U-NII Detection Bandwidth detection test, radar type 1 is used and for each frequency step the minimum percentage of detection is 90%. Measurements are performed with no data traffic.</p>	

8.2 DFS test results

8.2.1 Channel move time / channel closing transmission time

Description:

Channel Move Time. After a radar's presence is detected, all transmissions shall cease on the operating channel within 10 seconds. Transmissions during this period shall consist of normal traffic for a maximum of 200 ms after detection of the radar signal. In addition, intermittent management and control signals can be sent during the remaining time to facilitate vacating the operating channel.

Test Procedure:

Perform the test with one of the type 1 to type 4 short pulse radar waveforms.

Result: Channel 60 (Radar signal @ 1s)

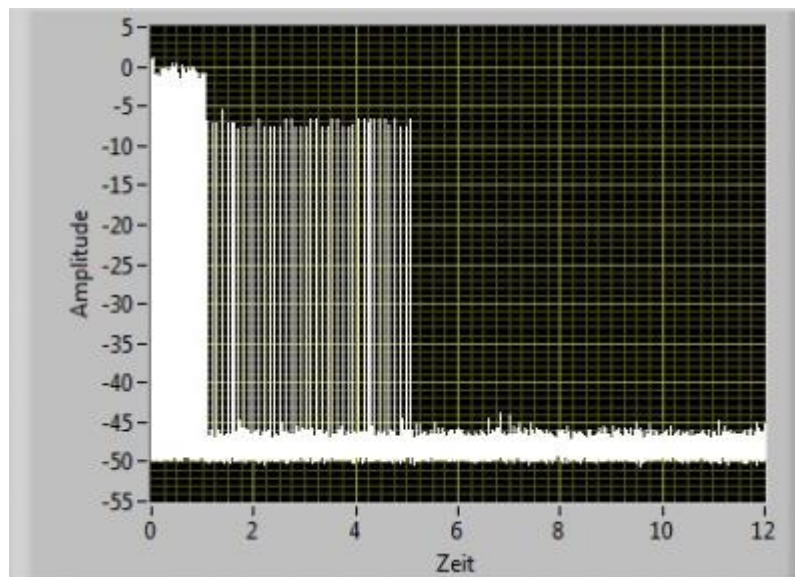

The arrow shows the time of the radar pulse. On the plot you can see that no transmissions occur from the AP after sending the radar burst. The time difference between the recognition of the radar burst by the AP and its last transmission is called as Channel Move Time (Limit: 10 s). The accumulated transmission time of the AP and for the slave device after detection of a radar signal is called channel closing transmission time (Limit: in total 200 ms + 60 ms).

The accumulated channel closing transmission time after 200ms of the slave device is less than 60 ms.

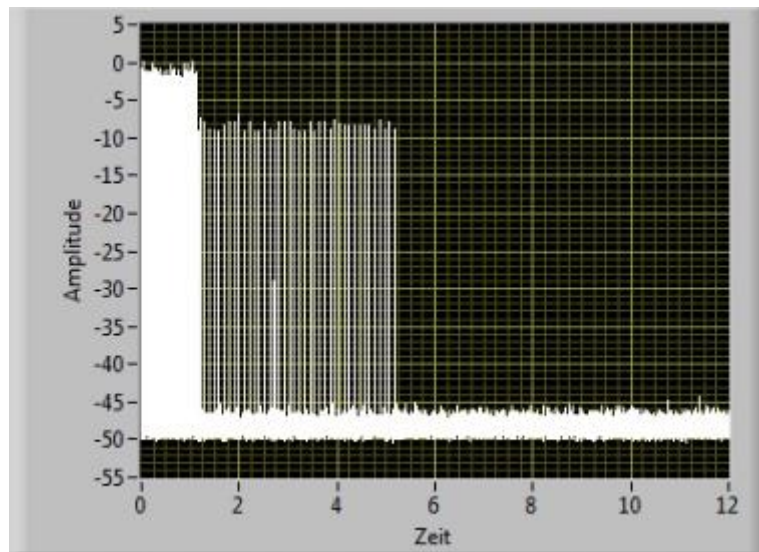
Result: Channel 140 (Radar signal @ 1s)

The arrow shows the time of the radar pulse. On the plot you can see that no transmissions occur from the AP after sending the radar burst. The time difference between the recognition of the radar burst by the AP and its last transmission is called as Channel Move Time (Limit: 10 s). The accumulated transmission time of the AP and for the slave device after detection of a radar signal is called channel closing transmission time (Limit: in total 200 ms + 60 ms).

The accumulated channel closing transmission time after 200ms of the slave device is less than 60 ms.

Verdict: [complies](#)

8.2.2 Non-Occupancy Period

Description:

Non-occupancy Period. A channel that has been flagged as containing a radar system, either by a channel availability check or in-service monitoring, is subject to a non-occupancy period of at least 30 minutes. The non-occupancy period starts at the time when the radar system is detected.

Plots: Non-Occupancy-Period

Channel 60:

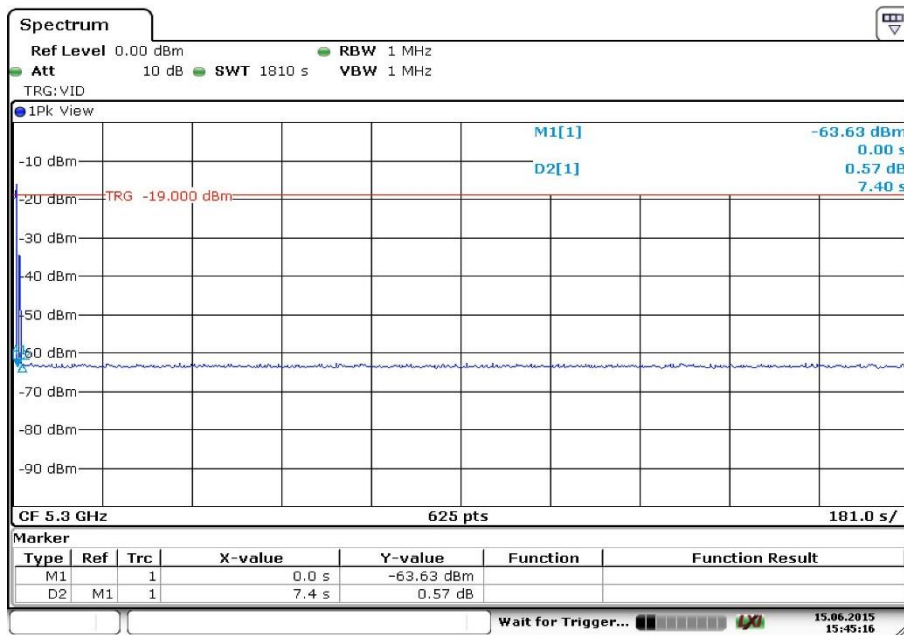

Date: 15 JUN.2015 15:45:16

In the plot above you can see, that the client does not transmit any emission within 30 minutes after having received the “stop transmit” order from the Access Point (DFS-Master).

Verdict: complies

9 Observations

No observations except those reported with the single test cases have been made.

Annex A Document history

Version	Applied changes	Date of release
	Initial release	2015-07-10

Annex B Further information

Glossary

AVG	-	Average
DUT	-	Device under test
EMC	-	Electromagnetic Compatibility
EN	-	European Standard
EUT	-	Equipment under test
ETSI	-	European Telecommunications Standard Institute
FCC	-	Federal Communication Commission
FCC ID	-	Company Identifier at FCC
HW	-	Hardware
IC	-	Industry Canada
Inv. No.	-	Inventory number
N/A	-	Not applicable
PP	-	Positive peak
QP	-	Quasi peak
S/N	-	Serial number
SW	-	Software
PMN		Product marketing name
HMN		Host marketing name
HVIN		Hardware version identification number
FVIN		Firmware version identification number

Annex C Accreditation Certificate

Front side of certificate

Back side of certificate



Deutsche Akkreditierungsstelle GmbH

Bellehene gemäß § 8 Absatz 1 AkkStelleG i.V.m. § 1 Absatz 1 AkkStelleGBV
 Unterzeichnerin der Multilateralen Abkommen
 von EA, ILAC und IAF zur gegenseitigen Anerkennung

Akkreditierung



Die Deutsche Akkreditierungsstelle GmbH bestätigt hiermit, dass das Prüflaboratorium

CETECOM ICT Services GmbH
 Untertürkheimer Straße 6-10, 66117 Saarbrücken

die Kompetenz nach DIN EN ISO/IEC 17025:2005 besitzt, Prüfungen in folgenden Bereichen durchzuführen:

- Drahtgebundene Kommunikation einschließlich xDSL
- VoIP und DECT
- Akustik
- Funk einschließlich WLAN
- Short Range Devices (SRD)
- RFID
- WiFiMax und Richtfunk
- Mobilfunk (GSM / GPRS, Over the Air (OTA) Performance)
- Elektromagnetische Verträglichkeit (EMV) einschließlich Automotive
- Produktsicherheit
- SAR und Hearing Aid Compatibility (HAC)
- Umweltsimulation
- Smart Card Terminals
- Bluetooth
- Wi-Fi Services

Die Akkreditierungsurkunde gilt nur in Verbindung mit dem Bescheid vom 07.03.2014 mit der Akkreditierungsnummer D-PL-12076-01 und ist gültig 17.01.2018. Sie besteht aus diesem Deckblatt, der Rückseite des Deckblatts und der folgenden Anlage mit insgesamt 77 Seiten.

Registrierungsnummer der Urkunde: D-PL-12076-01-00

Frankfurt am Main, 07.03.2014

Stellen Sie hier den Namen ein

19. Auflage DPL-12076-01, gültig ab 17.01.2018

Deutsche Akkreditierungsstelle GmbH

Standort Berlin
 Spittelmarkt 10
 10117 Berlin

Standort Frankfurt am Main
 Gartenstraße 6
 60594 Frankfurt am Main

Standort Braunschweig
 Bundesallee 100
 38116 Braunschweig

Die auszugsweise Veröffentlichung der Akkreditierungsurkunde bedarf der vorherigen schriftlichen Zustimmung der Deutsche Akkreditierungsstelle GmbH (DAkkS). Ausgenommen davon ist die separate Weiterverbreitung des Deckblattes durch die umseitig genannte Kurznormitätsbewertungsstelle in unveränderter Form.

Es darf nicht der Anschein erweckt werden, dass sich die Akkreditierung auch auf Bereiche erstreckt, die über den durch die DAkkS bestätigten Akkreditierungsbereich hinausgehen.

Die Akkreditierung erfolgte gemäß des Gesetzes über die Akkreditierungsstelle (AkkStelleG) vom 31. Juli 2009 (BGBl. I S. 2625) sowie der Verordnung (EG) Nr. 765/2008 des Europäischen Parlaments und des Rates vom 9. Juli 2008 über die Vorschriften für die Akkreditierung und Marktüberwachung im Zusammenhang mit der Vermarktung von Produkten (Abl. L 218 vom 9. Juli 2008, S. 30). Die DAkkS ist Unterzeichnerin der Multilateralen Abkommen zur gegenseitigen Anerkennung der Fertigkeiten von Organisationen für Akkreditierung (EA), des International Accreditation Forum (IAF) und der International Laboratory Accreditation Cooperation (ILAC). Die Unterzeichner dieser Abkommen erkennen ihre Akkreditierungen gegenseitig an.

Der aktuelle Stand der Mitgliedschaft kann folgenden Webseiten entnommen werden:
 EA: www.european-accreditation.org
 IAF: www.iaf.or.jp
 ILAC: www.ilac.org

Note:

The current certificate including annex is published on our website (see link below) or may be received from CETECOM ICT Services on request.

<http://www.cetecom.com/eu/de/cetecom-group/europa/deutschland-saarbruecken/akkreditierungen.html>