



# FCC Test Report

**Equipment** : Liberty Wireless Module  
**Brand Name** : Bowers & Wilkins  
**Model No.** : CC72036  
**FCC ID** : 2ACIX-LWM  
**Standard** : 47 CFR FCC Part 15.247  
**Operating Band** : 2400 MHz – 2483.5 MHz  
**Applicant** : B&W Group Ltd.  
Dale Road Worthing, West Sussex BN11 2BH, United Kingdom  
**Manufacturer** : B&W Group Ltd.  
Dale Road Worthing, West Sussex BN11 2BH, United Kingdom

The product sample received on Sep. 15, 2017 and completely tested on Nov. 17, 2017. We, SPORTON, would like to declare that the tested sample has been evaluated in accordance with the procedures given inanes and shown compliance with the applicable technical standards.

The test results in this report apply exclusively to the tested model / sample. Without written approval of SPORTON INTERNATIONAL INC., the test report shall not be reproduced except in full.

  
Cliff Chang  
SPORTON INTERNATIONAL INC.





# Table of Contents

- 1 GENERAL DESCRIPTION .....5**
- 1.1 Information.....5
- 1.2 Testing Applied Standards .....9
- 1.3 Testing Location Information .....9
- 1.4 Measurement Uncertainty .....9
- 2 TEST CONFIGURATION OF EUT .....10**
- 2.1 Test Channel Mode .....10
- 2.2 The Worst Case Measurement Configuration .....11
- 2.3 EUT Operation during Test .....12
- 2.4 Accessories .....13
- 2.5 Support Equipment.....13
- 2.6 Test Setup Diagram .....14
- 3 TRANSMITTER TEST RESULT .....17**
- 3.1 AC Power-line Conducted Emissions .....17
- 3.2 20dB Bandwidth and Carrier Frequency Separation .....19
- 3.3 Maximum Conducted Output Power .....20
- 3.4 Number of Hopping Frequencies and Hopping Bandedge .....21
- 3.5 Time of Occupancy (Dwell Time) .....22
- 3.6 Emissions in Non-restricted Frequency Bands .....23
- 3.7 Emissions in Restricted Frequency Bands.....24
- 4 TEST EQUIPMENT AND CALIBRATION DATA .....27**
- APPENDIX A. TEST RESULTS OF AC POWER-LINE CONDUCTED EMISSIONS**
- APPENDIX B. TEST RESULTS OF 20DB BANDWIDTH AND CARRIER FREQUENCY SEPARATION**
- APPENDIX C. TEST RESULTS OF MAXIMUM CONDUCTED OUTPUT POWER**
- APPENDIX D. TEST RESULTS OF NUMBER OF HOPPING FREQUENCIES AND HOPPING BANDEDGE**
- APPENDIX E. TEST RESULTS OF TIME OF OCCUPANCY (DWELL TIME)**
- APPENDIX F. TEST RESULTS OF EMISSIONS IN NON-RESTRICTED FREQUENCY BANDS**
- APPENDIX G. TEST RESULTS OF EMISSIONS IN RESTRICTED FREQUENCY BANDS**
- APPENDIX H. TEST RESULTS OF RADIATED EMISSION CO-LOCATION**
- APPENDIX I. TEST PHOTOS**
- APPENDIX J. PHOTOGRAPHS OF EUT**



### Summary of Test Result

Conformance Test Specifications				
Report Clause	Ref. Std. Clause	Description	Limit	Result
1.1.2	15.203	Antenna Requirement	FCC 15.203	Complied
3.1	15.207	AC Power-line Conducted Emissions	FCC 15.207	Complied
3.2	15.247(a)	20dB Bandwidth	15.247(a)	Complied
3.2	15.247(a)	Carrier Frequency Separation	15.247(a)	Complied
3.3	15.247(b)	Maximum Conducted Output Power	15.247(b)	Complied
3.4	15.247(a)	Number of Hopping Frequencies and Hopping Band edge	15.247(a)	Complied
3.5	15.247(a)	Time of Occupancy (Dwell Time)	15.247(a)	Complied
3.6	15.247(d)	Emissions in Non-restricted Frequency Bands	15.247(d)	Complied
3.7	15.247(d)	Emissions in Restricted Frequency Bands	Restricted Bands: FCC 15.209	Complied



## Revision History

Report No.	Version	Description	Issued Date
FR690630AC	Rev. 01	Initial issue of report	Dec. 15, 2017
FR690630AC	Rev. 02	Adding twelve dipole antennas	Jan. 08, 2018



# 1 General Description

## 1.1 Information

### 1.1.1 RF General Information

Frequency Range (MHz)	Bluetooth Version	Ch. Frequency (MHz)	Channel Number
2400-2483.5	BR / EDR	2402-2480	0-78 [79]

Band	Mode	BWch (MHz)	Nant
2.4G	BT-BR	1	1
2.4G	BT-EDR	1	1

Note:

- ♦ Bluetooth BR uses a GFSK (1Mbps).
- ♦ Bluetooth EDR uses a combination of  $\pi/4$ -DQPSK (2Mbps) and 8DPSK (3Mbps).
- ♦ Bluetooth BR/EDR uses as a system using FHSS modulation.
- ♦ BWch is the nominal channel bandwidth.
- ♦ Nss-Min is the minimum number of spatial streams.
- ♦ Nant is the number of outputs. e.g., 2(2, 3) means have 2 outputs for port 2 and port 3. 2 means have 2 outputs for port 1 and port 2.

1.1.2 Antenna Information

Ant.	Port	Radio	Brand	P/N	Antenna Type	Connector	Gain (dBi)		
							WLAN 2.4GHz	WLAN 5GHz	BT
1	1	R1	LUXSHARE ICT	DCIW303	Dipole Antenna	I-PEX	2.02	3.06	-
2	2	R1	LUXSHARE ICT	DCIW303	Dipole Antenna	I-PEX	2.02	-	-
3	1	R2	LUXSHARE ICT	DCIW303	Dipole Antenna	I-PEX	-	3.06	-
4	2	R2	LUXSHARE ICT	DCIW303	Dipole Antenna	I-PEX	-	3.06	-
5	1	R3/R4	LUXSHARE ICT	DCIW303	Dipole Antenna	I-PEX	-	3.06	2.02
6	2	R3	LUXSHARE ICT	DCIW303	Dipole Antenna	I-PEX	-	3.06	-
7	-	R2/R3	ACON	ZZ35343	Dipole Antenna	I-PEX 20670-001R -37	-	1.28	-
8	-	R1/R2/R3	ACON	ZZ35351	Dipole Antenna	I-PEX 20670-001R -37	1.92	2	-
9	-	R2/R3	ACON	ZZ35378	Dipole Antenna	I-PEX 20670-001R -37	-	1.77	-
10	-	R2/R3	ACON	ZZ35386	Dipole Antenna	I-PEX 20670-001R -37	-	2.93	-
11	-	R1	ACON	ZZ35394	Dipole Antenna	I-PEX 20670-001R -37	1.53	NA	-
12	-	R1/R2/R3/ R4	ACON	ZZ35408	Dipole Antenna	I-PEX 20670-001R -37	1.92	1.52	1.92
13	-	R2/R3	ACON	ZZ35491	Dipole Antenna	I-PEX 20670-001R -37	-	2.12	-
14	-	R1/R2/R3	ACON	ZZ35505	Dipole Antenna	I-PEX 20670-001R -37	1.94	2.88	-
15	-	R2/R3	ACON	ZZ35513	Dipole Antenna	I-PEX 20670-001R -37	-	1.73	-
16	-	R2/R3	ACON	ZZ35521	Dipole Antenna	I-PEX 20670-001R -37	-	1.41	-
17	-	R1	ACON	ZZ35548	Dipole Antenna	I-PEX 20670-001R -37	1.91	-	-
18	-	R1/R2/R3/ R4	ACON	ZZ35556	Dipole Antenna	I-PEX 20670-001R -37	1.62	0.46	1.62



Note: There are 18 antennas in the antenna table list, antenna 1~6 are the highest gain antennas.

They were selected to perform the test and recorded in this report.

**For 2.4GHz function:**

**Radio 1**

For IEEE 802.11b/g/n/ac mode (2TX/2RX)

Ant.1 (Port 1) and Ant.2 (Port 2) could transmit/receive simultaneously.

**For 5GHz function:**

**Radio 1 (For B1~B4)**

For IEEE 802.11a/n/ac mode (1RX)

Only Ant.1 (Port 1) can be used as receiving antenna.

**Radio 2 (For B3~B4)**

For IEEE 802.11a/n/ac mode (2TX/2RX)

Ant.3 (Port 1) and Ant.4 (Port 2) could transmit/receive simultaneously.

**Radio 3 (For B1~B2)**

For IEEE 802.11a/n mode (2TX/2RX)

Ant.5 (Port 1) and Ant.6 (Port 2) could transmit/receive simultaneously.

**For bluetooth function:**

**Radio 4**

For bluetooth mode (1TX/1RX)

Only Ant.5 (Port 1) can be used as transmitting/receiving antenna.

**1.1.3 Mode Test Duty Cycle**

Mode	DC	DCF(dB)	T(s)	VBW(Hz) ≥ 1/T
BT-BR(1Mbps)	0.828	0.82	2.906m	1k
BT-EDR(2Mbps)	0.791	1.018	2.915m	1k
BT-EDR(3Mbps)	0.763	1.175	2.916m	1k



1.1.4 EUT Operational Condition

EUT Power Type	From host system
Test Software Version	Blue Test3

1.1.5 Table for EUT functions

Radio	2.4GHz & 5GHz (B1~B4) (5GHz Scanning only)	5GHz (B1&B2)	5GHz (B3&B4)	Bluetooth
1	V	-	-	-
2	-	-	V	-
3	-	V	-	-
4	-	-	-	V

Type of function	2.4GHz (Radio 1)	5GHz (B1&B2) (Radio 3)	5GHz (B3&B4) (Radio 2)	5GHz (Radio 1) (B1~B4) (Scanning only)	Bluetooth (Radio 4)
AP Mode (Master)	N/A	V	V	V	V
Station Mode (Slave without radar detection)	V	V	V	N/A	V
Station Mode (Slave without radar detection)	N/A	V	V	V	V
Test Mode	2.4GHz (Radio 1)	5GHz (B1&B2) (Radio 3)	5GHz (B3&B4) (Radio 2)	5GHz (Radio 1) (B1~B4) (Scanning only)	Bluetooth (Radio 4)
AP Mode (For lisen and Emissions in Non-restricted Frequency Bands below 1GHz)	Station Mode	AP Mode	AP Mode	Not work (Note)	Not work (Note)
Station Mode	Station Mode	Station Mode	Station Mode	Not work (Note)	Not work (Note)
For Radiated Emission Co-location					
AP Mode	Station Mode	AP Mode	AP Mode	Not work (Note)	AP Mode

Note: Normal link does not support BT link and RX Scanning function.



## 1.2 Testing Applied Standards

According to the specifications of the manufacturer, the EUT must comply with the requirements of the following standards:

- ◆ 47 CFR FCC Part 15
- ◆ FCC Public Notice DA 00-705

## 1.3 Testing Location Information

Testing Location		
<input type="checkbox"/>	HWA YA	ADD : No. 52, Hwa Ya 1st Rd., Kwei-Shan Hsiang, Tao Yuan Hsien, Taiwan, R.O.C. TEL : 886-3-327-3456 FAX : 886-3-318-0055
<input checked="" type="checkbox"/>	JHUBEI	ADD : No.8, Lane 724, Bo-ai St., Jhubei City, HsinChu County 302, Taiwan, R.O.C. TEL : 886-3-656-9065 FAX : 886-3-656-9085

Test Condition	Test Site No.	Test Engineer	Test Environment	Test Date
RF Conducted	TH01-CB	Brian Sun & Eddie Weng	22°C / 54%	Sep. 26, 2017 ~ Nov. 16, 2017
Radiated	03CH01-CB	Paul Chen & DK Chang & Justin Lin & Joy Tseng & Zero Chen & Mason Chen	22°C / 54%	Sep. 28, 2017 ~ Oct. 06, 2017
AC Conduction	CO01-CB	Max Lin	25°C / 59%	Nov. 17, 2017

Test site Designation No. TW0006 with FCC.

Test site registered number IC 4086D with Industry Canada.

## 1.4 Measurement Uncertainty

ISO/IEC 17025 requires that an estimate of the measurement uncertainties associated with the emissions test results be included in the report. The measurement uncertainties given below are based on a 95% confidence level (based on a coverage factor (k=2))

Test Items	Uncertainty	Remark
Conducted Emission (150kHz ~ 30MHz)	3.2 dB	Confidence levels of 95%
Radiated Emission (30MHz ~ 1,000MHz)	3.6 dB	Confidence levels of 95%
Radiated Emission (1GHz ~ 18GHz)	3.7 dB	Confidence levels of 95%
Radiated Emission (18GHz ~ 40GHz)	3.5 dB	Confidence levels of 95%
Conducted Emission	1.7 dB	Confidence levels of 95%
Output Power Measurement	1.33 dB	Confidence levels of 95%
Bandwidth Measurement	9.74 x10 <sup>-8</sup>	Confidence levels of 95%



## 2 Test Configuration of EUT

### 2.1 Test Channel Mode

Mode	Power Setting
BT-BR(1Mbps)	-
2402MHz	63
2440MHz	63
2480MHz	55
BT-EDR(2Mbps)	-
2402MHz	63
2440MHz	63
2480MHz	63
BT-EDR(3Mbps)	-
2402MHz	63
2440MHz	63
2480MHz	61

## 2.2 The Worst Case Measurement Configuration

The Worst Case Mode for Following Conformance Tests	
<b>Tests Item</b>	AC power-line conducted emissions
<b>Condition</b>	AC power-line conducted measurement for line and neutral
<b>Operating Mode</b>	Normal Link
1	AP Mode
2	Station Mode
Mode 2 generated the worst test result, so it was recorded in this report.	

The Worst Case Mode for Following Conformance Tests	
<b>Tests Item</b>	20dB Bandwidth Carrier Frequency Separation Maximum Conducted Output Power Number of Hopping Frequencies Hopping Bandedge Time of Occupancy (Dwell Time) Emissions in Non-restricted Frequency Bands
<b>Test Condition</b>	Conducted measurement at transmit chains

The Worst Case Mode for Following Conformance Tests	
<b>Tests Item</b>	Emissions in Restricted Frequency Bands
<b>Test Condition</b>	Radiated measurement If EUT consist of multiple antenna assembly (multiple antenna are used in EUT regardless of spatial multiplexing MIMO configuration), the radiated test should be performed with highest antenna gain of each antenna type.
<b>Operating Mode &lt; 1GHz</b>	Normal Link
1	AP Mode-EUT in Y axis
2	AP Mode-EUT in Z axis
Mode 1 has been evaluated to be the worst case among Mode 1~2, thus measurement for Mode 3 will follow this same test mode.	
3	Station Mode-EUT in Y axis
Mode 1 generated the worst test result, so it was recorded in this report.	
<b>Operating Mode &gt; 1GHz</b>	CTX
	The EUT was performed at X axis, Y axis and Z axis position for Emissions in Restricted Frequency Bands above 1GHz test, and the worst case was found at Z axis. So the measurement will follow this same test configuration.
1	EUT in Z axis



The Worst Case Mode for Following Conformance Tests	
Tests Item	Simultaneous Transmission Analysis - Radiated Emission Co-location
Test Condition	Radiated measurement
Operating Mode	Normal Link
1	EUT in X axis - R1 (2.4G / Station mode) + R3 (5G B1~B2 / AP mode) + R2 (5G B3~B4 / AP mode) + R4 (BT / AP mode)
2	EUT in Y axis - R1 (2.4G / Station mode) + R3 (5G B1~B2 / AP mode) + R2 (5G B3~B4 / AP mode) + R4 (BT / AP mode)
3	EUT in Z axis - R1 (2.4G / Station mode) + R3 (5G B1~B2 / AP mode) + R2 (5G B3~B4 / AP mode) + R4 (BT / AP mode)
Mode 3 generated the worst test result, so it was recorded in this report.	
Refer to Appendix H for Radiated Emission Co-location.	

The Worst Case Mode for Following Conformance Tests	
Tests Item	Simultaneous Transmission Analysis - Co-location RF Exposure Evaluation
Operating Mode	
1	R1 (2.4G) + R3 (5G B1~B2) + R2 (5G B3~B4) + R4 (BT)
Refer to Sporton Test Report No.: FA790630 for Co-location RF Exposure Evaluation.	

Note: All the specification of test configurations and test modes were based on customer's request.

### 2.3 EUT Operation during Test

For CTX Mode:

The EUT was programmed to be in continuously transmitting mode.

For Normal Link:

During the test, the EUT operation to normal function.



## 2.4 Accessories

N/A

## 2.5 Support Equipment

For Test Site No: CO01-CB

Support Equipment				
No.	Equipment	Brand Name	Model Name	FCC ID
1	NB*4	DELL	E6430	DoC
2	AP Router*3	Planex	GW-AP54SGX	KA220030603014-1
3	Mouse	Logitech	M-U0026	DoC
4	Earphone	e-Power	S90W	DoC
5	Test fixture	Arcadyan	WN9722BTBAC22-WB JIG TEST	N/A

For Test Site No: 03CH01-CB (below 1GHz)

Support Equipment				
No.	Equipment	Brand Name	Model Name	FCC ID
1	NB*4	DELL	E4300	DoC
2	WLAN AP	D-LINK	DIR860L	KA2IR860LA1
3	Mouse	Logitech	M-U0026	DoC
4	Earphone	SHYARO CHI	MIC-04	N/A
5	Test fixture	Arcadyan	WN9722BTBAC22-WB JIG TEST	N/A

For Test Site No: 03CH01-CB (above 1GHz)

Support Equipment				
No.	Equipment	Brand Name	Model Name	FCC ID
1	NB	DELL	E4300	DoC
2	Test fixture	Arcadyan	WN9722BTBAC22-WB JIG TEST	N/A

For Test Site No: TH01-CB

Support Equipment				
No.	Equipment	Brand Name	Model Name	FCC ID
1	NB	DELL	E4300	DoC
2	Test fixture	Arcadyan	WN9722BTBAC22-WB JIG TEST	N/A

## 2.6 Test Setup Diagram

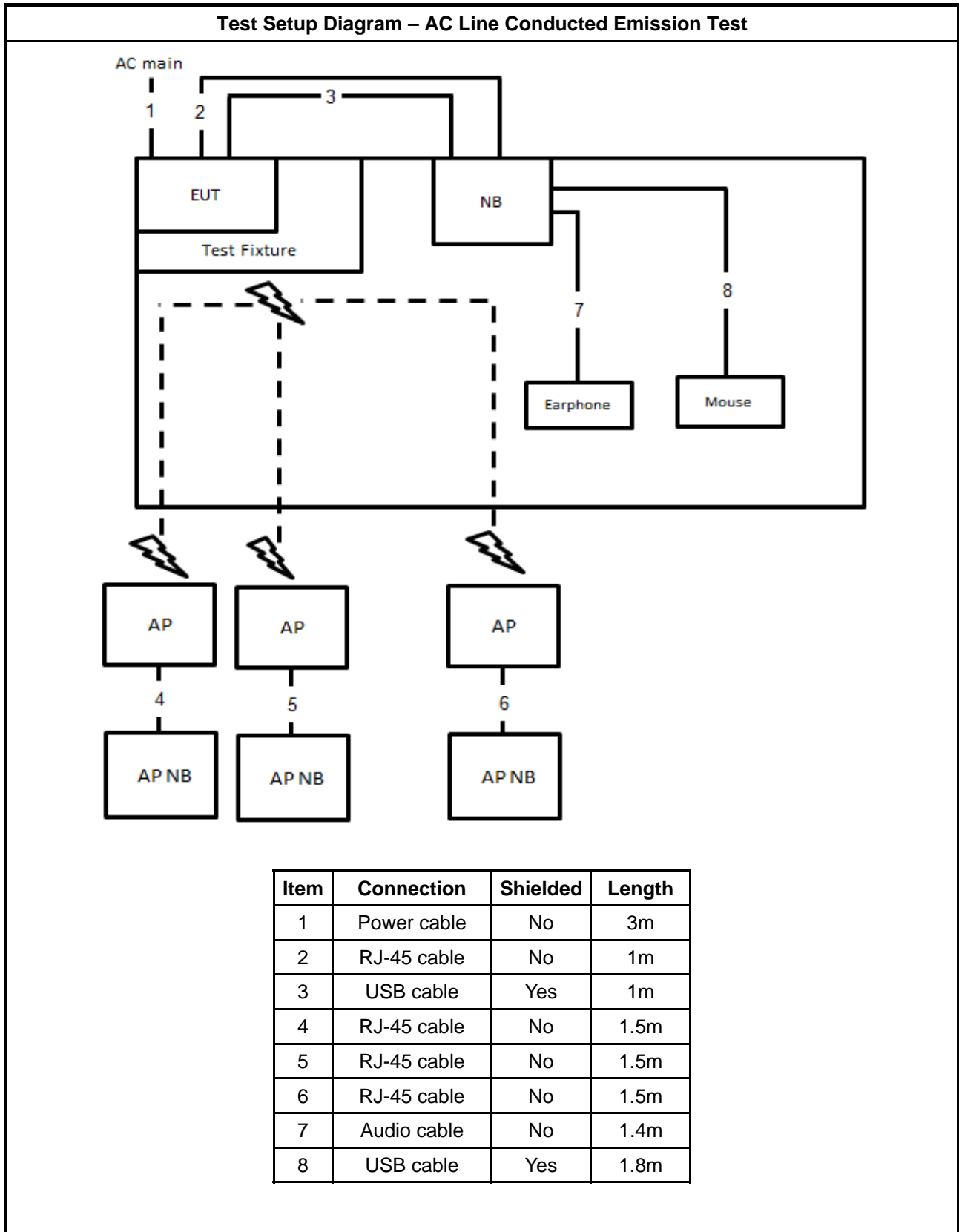

Test Setup Diagram - Radiated Test < 1GHz

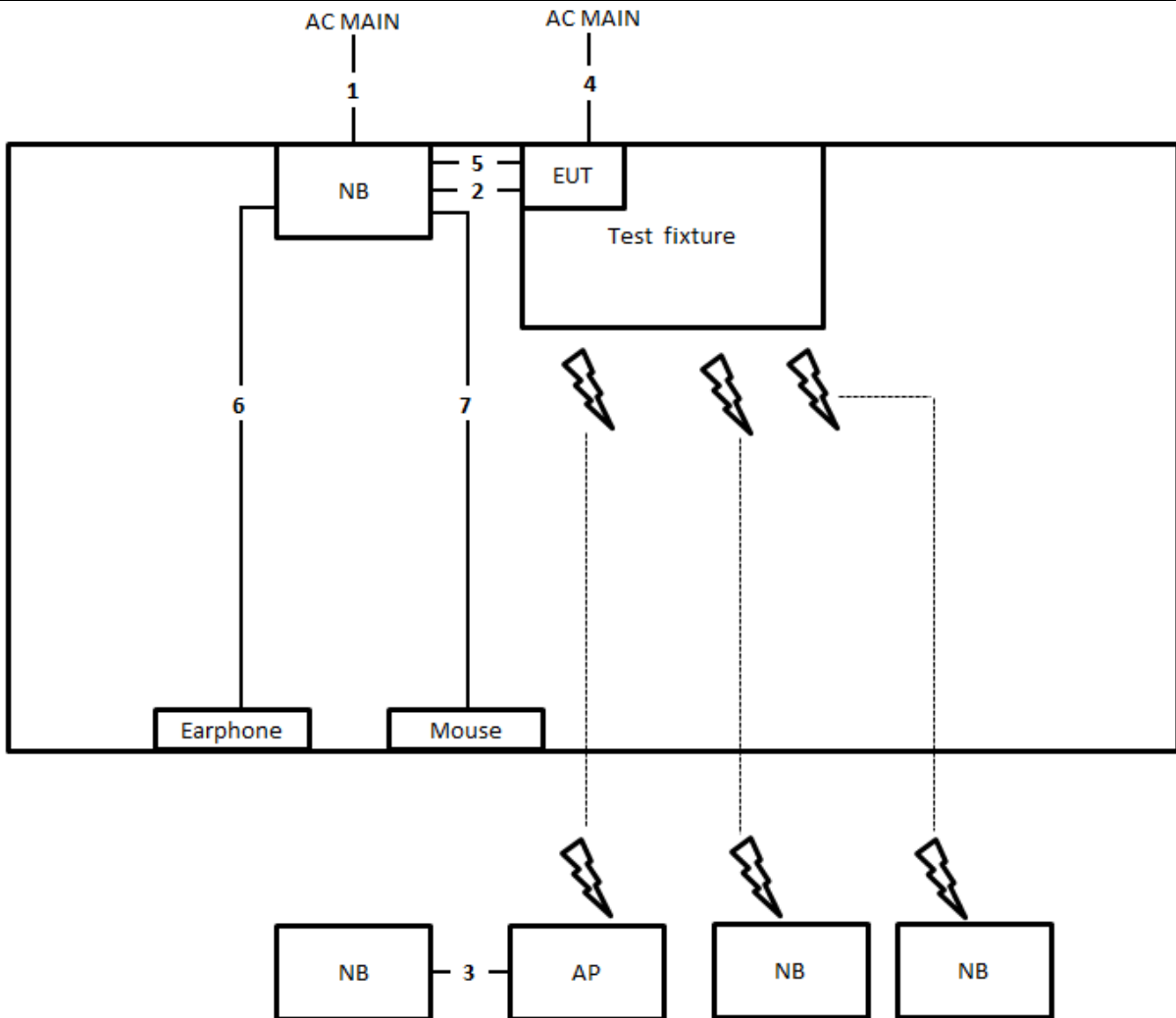

Item	Connection	Shielded	Length
1	Power cable	No	3m
2	USB cable	Yes	1m
3	RJ-45 cable	No	1.5m
4	Power cable	No	1.3m
5	USB cable	Yes	1m
6	Audio cable	No	1.1m
7	USB cable	Yes	1.8m

Test Setup Diagram - Radiated Test > 1GHz

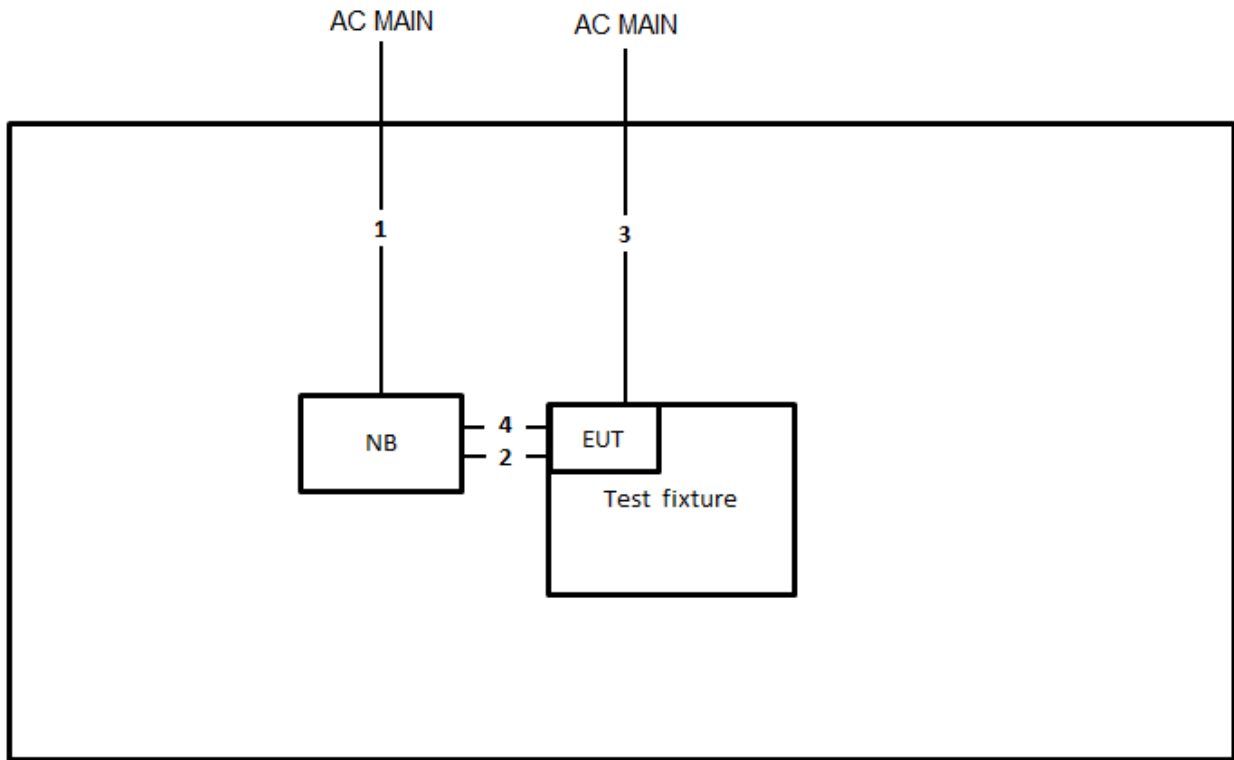

Item	Connection	Shielded	Length
1	Power cable	No	3m
2	USB cable	Yes	1m
3	Power cable	No	1.3m
4	USB cable	Yes	1m



### 3 Transmitter Test Result

#### 3.1 AC Power-line Conducted Emissions

##### 3.1.1 AC Power-line Conducted Emissions Limit

AC Power-line Conducted Emissions Limit		
Frequency Emission (MHz)	Quasi-Peak	Average
0.15-0.5	66 - 56 *	56 - 46 *
0.5-5	56	46
5-30	60	50

Note 1: \* Decreases with the logarithm of the frequency.

##### 3.1.2 Measuring Instruments

Refer a test equipment and calibration data table in this test report.

##### 3.1.3 Test Procedures

Test Method
<ul style="list-style-type: none"> <li>Refer as ANSI C63.10-2013, clause 6.2 for AC power-line conducted emissions.</li> </ul>

##### 3.1.4 Test Setup

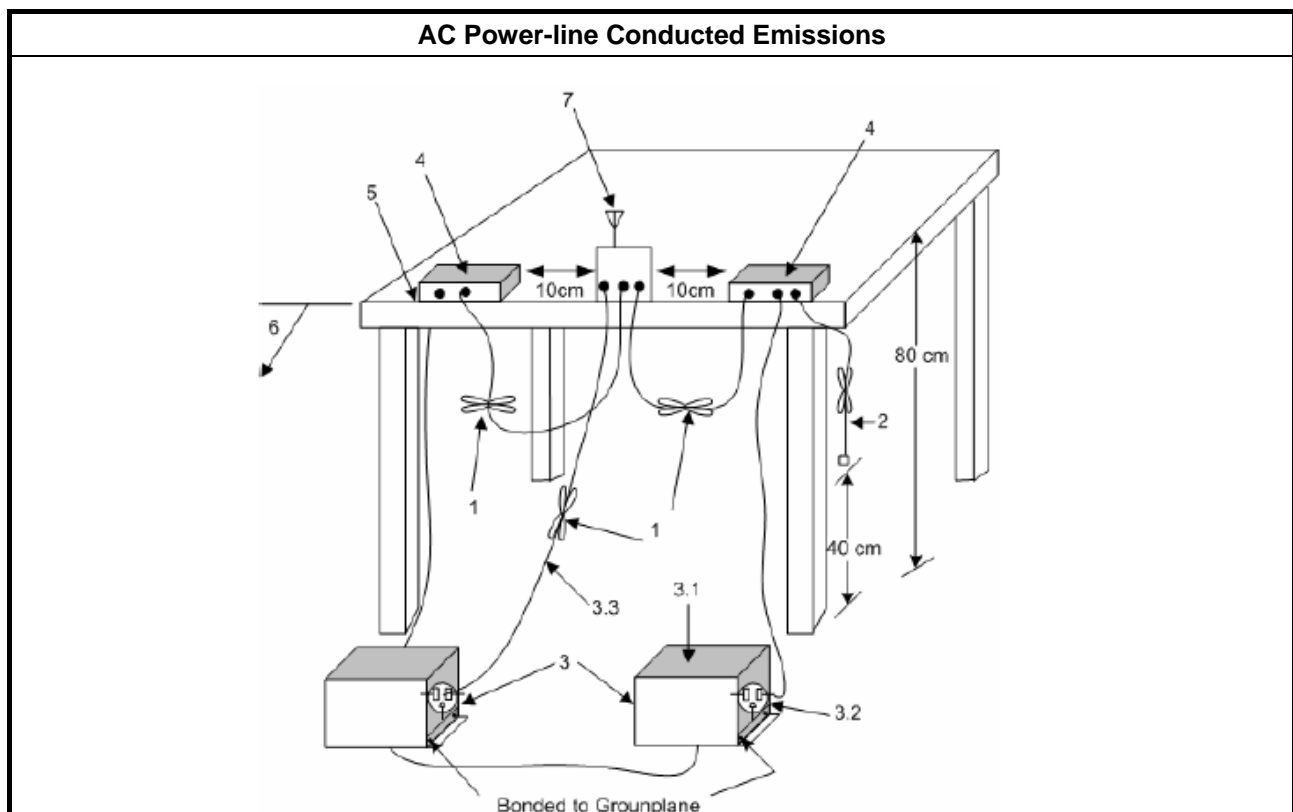



### **3.1.5 Test Result of AC Power-line Conducted Emissions**

Refer as Appendix A

### 3.2 20dB Bandwidth and Carrier Frequency Separation

#### 3.2.1 20dB Bandwidth and Carrier Frequency Separation Limit

20dB Bandwidth and Carrier Frequency Separation Limit for Frequency Hopping Systems	
<ul style="list-style-type: none"> <li>902-928 MHz Band:               <ul style="list-style-type: none"> <li><math>N \geq 50</math> and <math>ChS \geq \text{MAX}</math> (20 dB bandwidth, 25 kHz); 20 dB bandwidth <math>\leq</math> 250 kHz.</li> <li><math>50 &gt; N \geq 25</math> and <math>ChS \geq \text{MAX}</math> (20 dB bandwidth, 25 kHz); 20 dB bandwidth <math>&gt;</math> 250 kHz.</li> </ul> </li> </ul>	
<ul style="list-style-type: none"> <li>2400-2483.5 MHz Band:               <ul style="list-style-type: none"> <li><math>N \geq 75</math> and <math>ChS \geq \text{MAX}</math> (20 dB bandwidth, 25 kHz).</li> <li><math>75 &gt; N \geq 15</math> and <math>ChS \geq \text{MAX}</math> (20 dB bandwidth 2/3, 25 kHz).</li> </ul> </li> </ul>	
<ul style="list-style-type: none"> <li>5725-5850 MHz Band:               <ul style="list-style-type: none"> <li><math>N \geq 75</math> and <math>ChS \geq \text{MAX}</math> (20 dB bandwidth, 25 kHz); 20 dB bandwidth <math>\leq</math> 1 MHz.</li> </ul> </li> </ul>	
<b>N:</b> Number of Hopping Frequencies; <b>ChS:</b> Hopping Channel Separation	

#### 3.2.2 Measuring Instruments

Refer a test equipment and calibration data table in this test report.

#### 3.2.3 Test Procedures

Test Method
<ul style="list-style-type: none"> <li>Refer as ANSI C63.10-2013, clause 6.9.1 for 20 dB bandwidth measurement.</li> </ul>
<ul style="list-style-type: none"> <li>Refer as ANSI C63.10-2013, clause 7.8.2 for carrier frequency separation measurement.</li> </ul>

#### 3.2.4 Test Setup

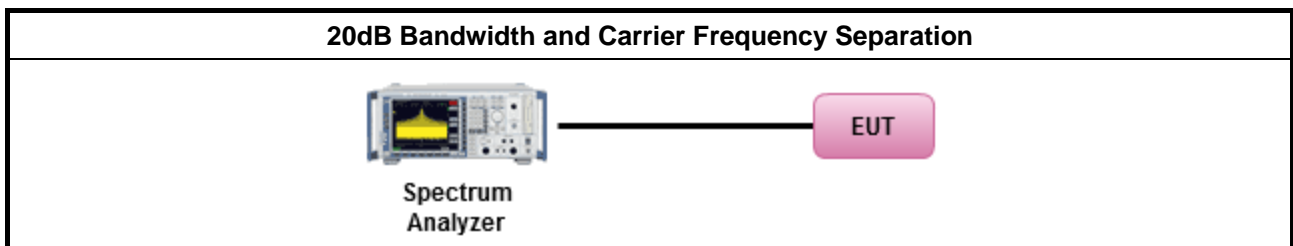

#### 3.2.5 Test Result of 20dB Bandwidth

Refer as Appendix B

#### 3.2.6 Test Result of Carrier Frequency Separation

Refer as Appendix B

### 3.3 Maximum Conducted Output Power

#### 3.3.1 Maximum Conducted Output Power Limit

Maximum Conducted Output Power Limit	
<ul style="list-style-type: none"> <li>▪ 902-928 MHz Band:</li> </ul>	
	<ul style="list-style-type: none"> <li>▪ <math>N \geq 50</math>; Power 30dBm; EIRP 36dBm</li> </ul>
	<ul style="list-style-type: none"> <li>▪ <math>50 &gt; N \geq 25</math>; Power 24dBm; EIRP 30dBm</li> </ul>
<ul style="list-style-type: none"> <li>▪ 2400-2483.5 MHz Band:</li> </ul>	
	<ul style="list-style-type: none"> <li>▪ <math>N \geq 75</math>; Power 30dBm; EIRP 36dBm</li> </ul>
	<ul style="list-style-type: none"> <li>▪ <math>75 &gt; N \geq 15</math>; Power 21dBm; EIRP 27dBm</li> </ul>
<ul style="list-style-type: none"> <li>▪ 5725-5850 MHz Band:</li> </ul>	
	<ul style="list-style-type: none"> <li>▪ <math>N \geq 75</math>; Power 30dBm; EIRP 36dBm</li> </ul>
N: Number of Hopping Frequencies	

#### 3.3.2 Measuring Instruments

Refer a test equipment and calibration data table in this test report.

#### 3.3.3 Test Procedures

Test Method
<ul style="list-style-type: none"> <li>▪ Refer as ANSI C63.10-2013, clause 7.8.5 for output power measurement.</li> </ul>

#### 3.3.4 Test Setup

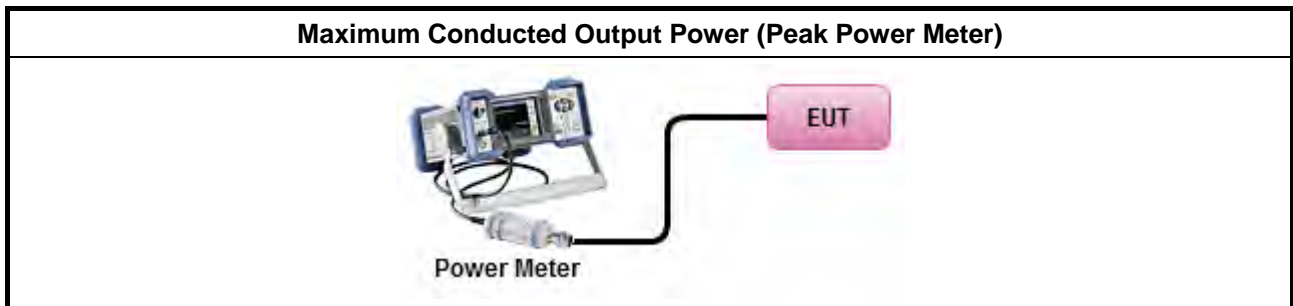

#### 3.3.5 Test Result of Maximum Conducted Output Power

Refer as Appendix C

### 3.4 Number of Hopping Frequencies and Hopping Bandedge

#### 3.4.1 Number of Hopping Frequencies Limit

Number of Hopping Frequencies Limit	
▪ 902-928 MHz Band:	
	▪ $N \geq 50$ and $ChS \geq MAX$ (20 dB bandwidth, 25 kHz); 20 dB bandwidth $\leq$ 250 kHz.
	▪ $50 > N \geq 25$ and $ChS \geq MAX$ (20 dB bandwidth, 25 kHz); 20 dB bandwidth $>$ 250 kHz.
▪ 2400-2483.5 MHz Band:	
	▪ $N \geq 75$ and $ChS \geq MAX$ (20 dB bandwidth, 25 kHz).
	▪ $75 > N \geq 15$ and $ChS \geq MAX$ (20 dB bandwidth 2/3, 25 kHz).
▪ 5725-5850 MHz Band:	
	▪ $N \geq 75$ and $ChS \geq MAX$ (20 dB bandwidth, 25 kHz); 20 dB bandwidth $\leq$ 1 MHz.
N: Number of Hopping Frequencies; ChS : Hopping Channel Separation	

#### 3.4.2 Hopping Bandedge Limit

Refer clause 3.6.1 and clause 3.7.1

#### 3.4.3 Measuring Instruments

Refer a test equipment and calibration data table in this test report.

#### 3.4.4 Test Procedures

Test Method
▪ Refer as ANSI C63.10-2013, clause 7.8.3 for number of hopping frequencies measurement.
▪ Refer as ANSI C63.10-2013, clause 7.8.6 for hopping frequencies Bandedge measurement.

#### 3.4.5 Test Setup

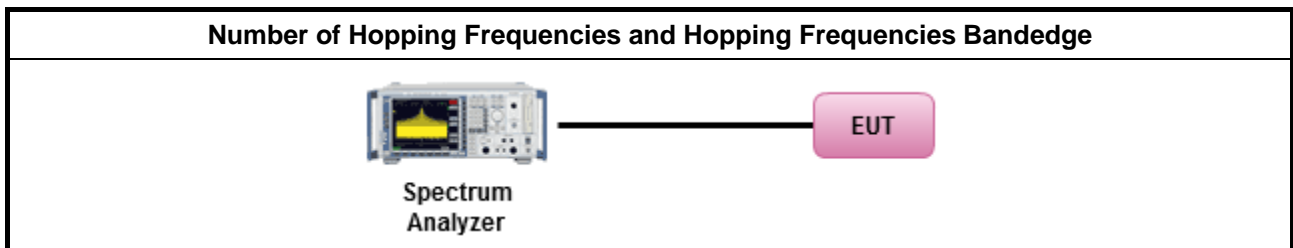

#### 3.4.6 Test Result of Number of Hopping Frequencies

Refer as Appendix D

#### 3.4.7 Test Result of Number of Hopping Frequencies Bandedge

Refer as Appendix D

### 3.5 Time of Occupancy (Dwell Time)

#### 3.5.1 Time of Occupancy (Dwell Time) Limit

20dB Bandwidth and Carrier Frequency Separation Limit for Frequency Hopping Systems	
▪ 902-928 MHz Band:	
	▪ $N \geq 50$ ; 0.4s in 20s period
	▪ $50 > N \geq 25$ ; 0.4s in 10s period
▪ 2400-2483.5 MHz Band:	
	▪ $N \geq 75$ ; 0.4s in $N \times 0.4$ period
	▪ $75 > N \geq 15$ ; 0.4s in $N \times 0.4$ period
▪ 5725-5850 MHz Band:	
	▪ $N \geq 75$ ; 0.4s in 30s period
N: Number of Hopping Frequencies	

#### 3.5.2 Measuring Instruments

Refer a test equipment and calibration data table in this test report.

#### 3.5.3 Test Procedures

Test Method	
▪ Refer as ANSI C63.10-2013, clause 7.8.4 for dwell time measurement.	
▪ Bluetooth ACL packets can be 1, 3, or 5 time slots. Following as dwell time. Operate DH5 at maximum dwell time and maximum duty cycle.	
	▪ The DH5 packet can cover up to 5 time slots. Operate DH5 at maximum dwell time and maximum duty cycle. A maximum length packet has duration of 5 time slots. The hopping rate is 1600 hops/second so the maximum dwell time is $5/1600$ seconds, or 3.125ms. DH5 Packet permit maximum $1600 / 79 / 6 = 3.37$ hops per second in each channel.

#### 3.5.4 Test Setup

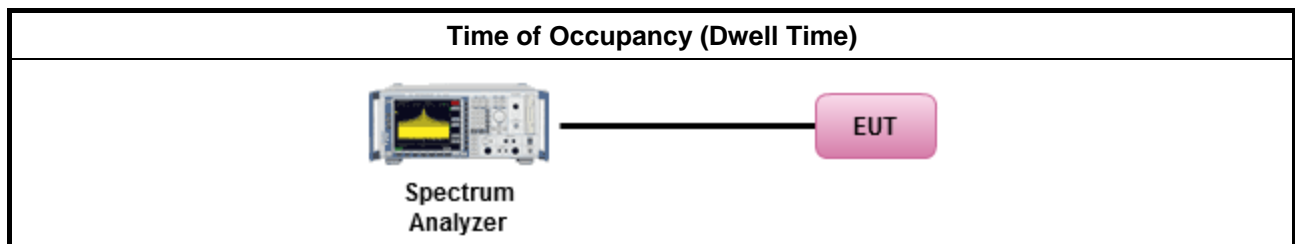

#### 3.5.5 Test Result of Time of Occupancy (Dwell Time)

Refer as Appendix E

### 3.6 Emissions in Non-restricted Frequency Bands

#### 3.6.1 Emissions in Non-restricted Frequency Bands Limit

Un-restricted Band Emissions Limit	
RF output power procedure	Limit (dB)
Peak output power procedure	20
Note 1: If the peak output power procedure is used to measure the fundamental emission power to demonstrate compliance to requirements, then the peak conducted output power measured within any 100 kHz outside the authorized frequency band shall be attenuated by at least 20 dB relative to the maximum measured in-band peak PSD level.	

#### 3.6.2 Measuring Instruments

Refer a test equipment and calibration data table in this test report.

#### 3.6.3 Test Procedures

Test Method
<ul style="list-style-type: none"> <li>Refer as ANSI C63.10-2013, clause 7.8.8 for unwanted emissions into non-restricted bands.</li> </ul>

#### 3.6.4 Test Setup

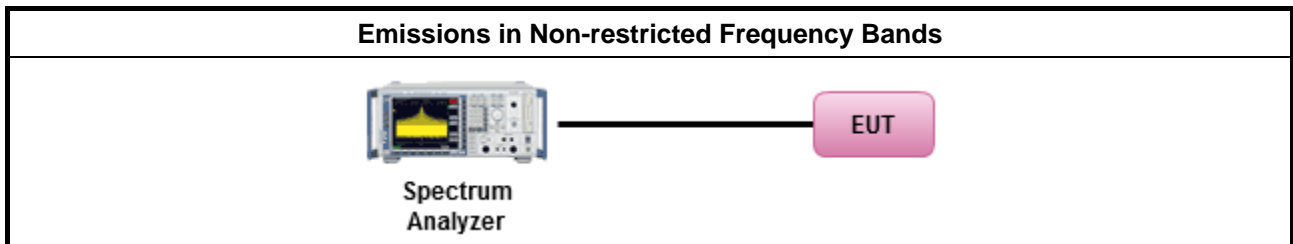

#### 3.6.5 Test Result of Emissions in Non-restricted Frequency Bands

Refer as Appendix F

### 3.7 Emissions in Restricted Frequency Bands

#### 3.7.1 Emissions in Restricted Frequency Bands Limit

Restricted Band Emissions Limit			
Frequency Range (MHz)	Field Strength (uV/m)	Field Strength (dBuV/m)	Measure Distance (m)
0.009~0.490	2400/F(kHz)	48.5 - 13.8	300
0.490~1.705	24000/F(kHz)	33.8 - 23	30
1.705~30.0	30	29	30
30~88	100	40	3
88~216	150	43.5	3
216~960	200	46	3
Above 960	500	54	3

Note 1: Test distance for frequencies at or above 30 MHz, measurements may be performed at a distance other than the limit distance provided they are not performed in the near field and the emissions to be measured can be detected by the measurement equipment. When performing measurements at a distance other than that specified, the results shall be extrapolated to the specified distance using an extrapolation factor of 20 dB/decade (inverse of linear distance for field-strength measurements, inverse of linear distance-squared for power-density measurements).

Note 2: Test distance for frequencies at below 30 MHz, measurements may be performed at a distance closer than the EUT limit distance; however, an attempt should be made to avoid making measurements in the near field. When performing measurements below 30 MHz at a closer distance than the limit distance, the results shall be extrapolated to the specified distance by either making measurements at a minimum of two or more distances on at least one radial to determine the proper extrapolation factor or by using the square of an inverse linear distance extrapolation factor (40 dB / decade). The test report shall specify the extrapolation method used to determine compliance of the EUT.

Note 3: Using the distance of 1m during the test for above 18 GHz, and the test value to correct for the distance factor at 3m.

#### 3.7.2 Measuring Instruments

Refer a test equipment and calibration data table in this test report.

#### 3.7.3 Test Procedures

Test Method	
	<ul style="list-style-type: none"> <li>▪ The average emission levels shall be measured in [hopping duty factor].</li> </ul>
	<ul style="list-style-type: none"> <li>▪ Refer as ANSI C63.10; clause 6.9.2.2 band-edge testing shall be performed at the lowest frequency channel and highest frequency channel within the allowed operating band.</li> </ul>
	<ul style="list-style-type: none"> <li>▪ For the transmitter unwanted emissions shall be measured using following options below:</li> </ul>
	<ul style="list-style-type: none"> <li>▪ Refer as ANSI C63.10, clause 4.1.4.2.1 QP value.</li> </ul>
	<ul style="list-style-type: none"> <li>▪ Refer as ANSI C63.10, clause 4.1.4.2.2 measurement procedure peak.</li> </ul>
	<ul style="list-style-type: none"> <li>▪ Refer as ANSI C63.10, clause 4.1.4.2.4 average value of hopping pulsed emissions.</li> </ul>



### 3.7.4 Test Setup

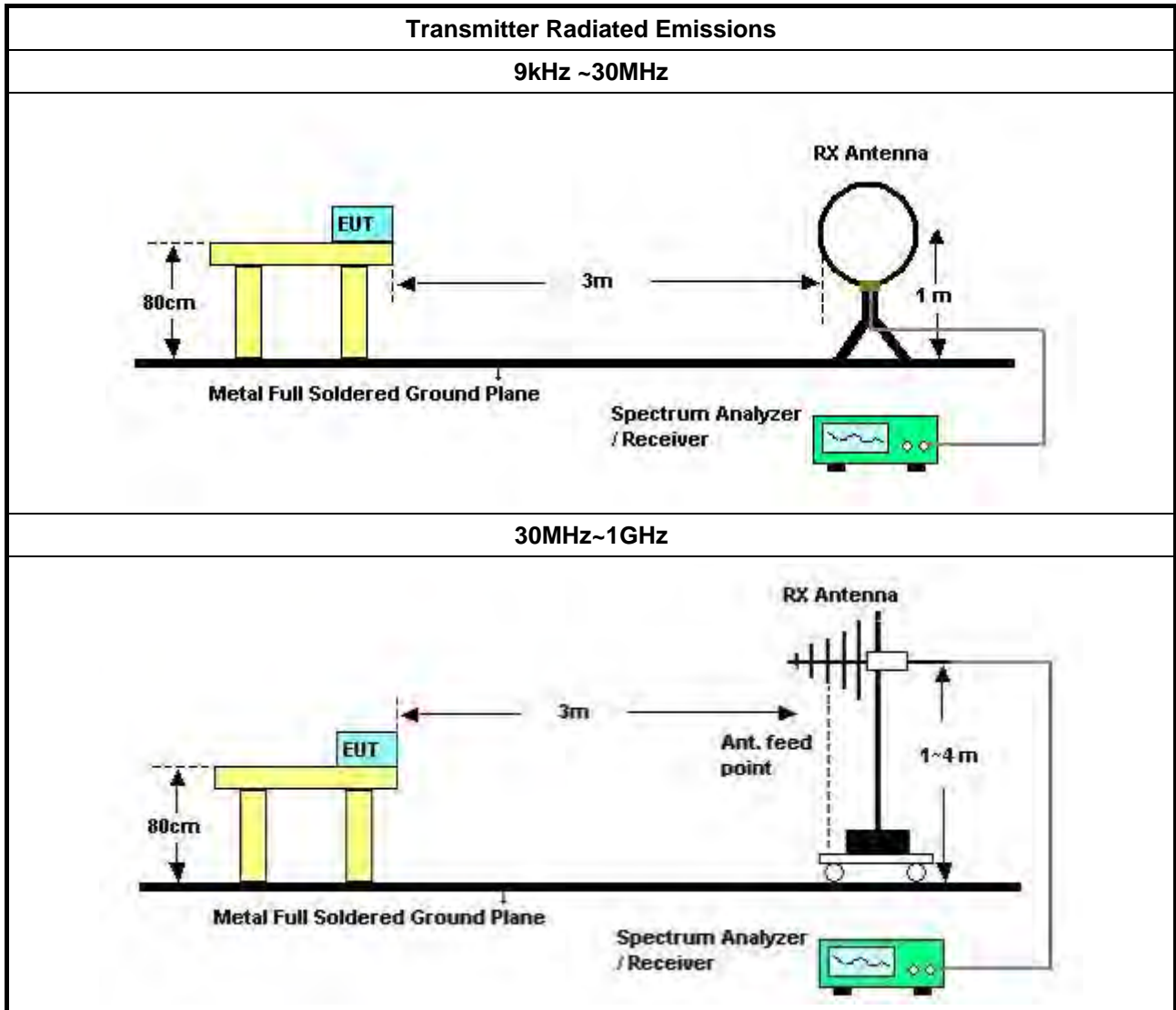

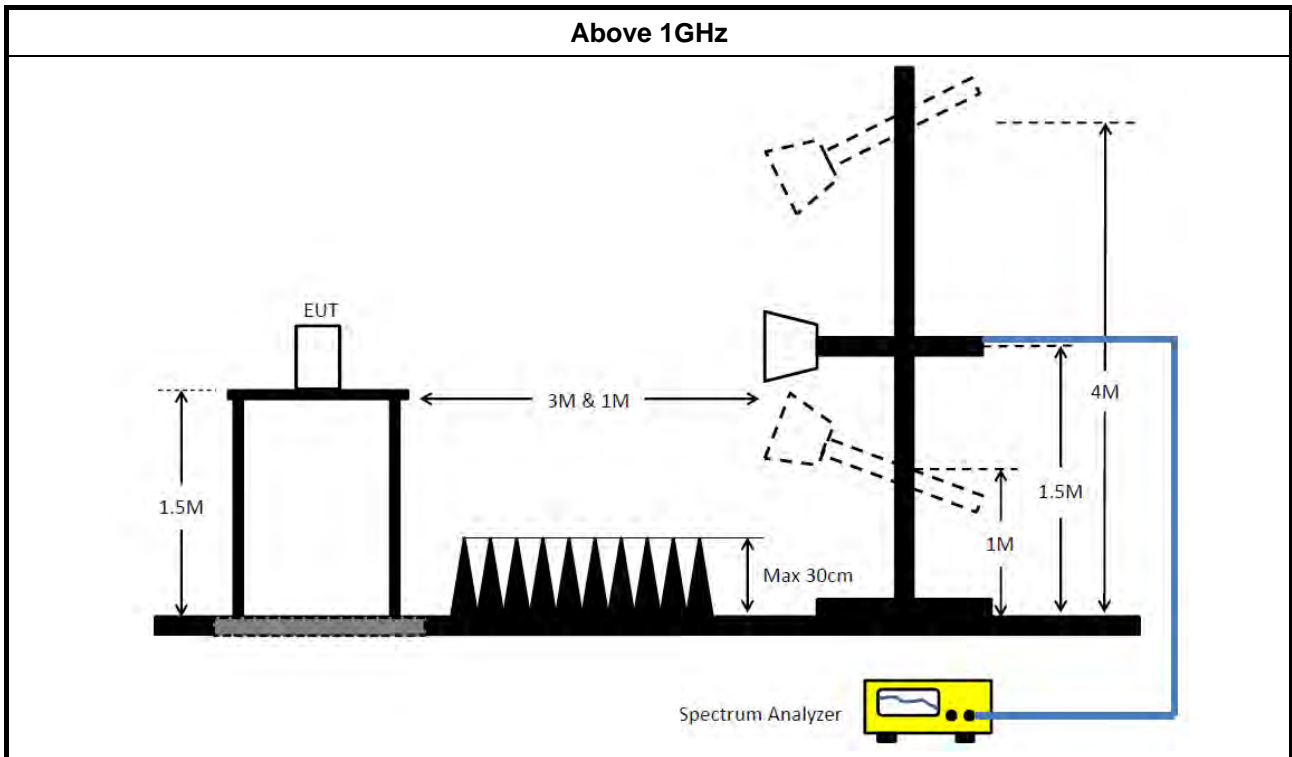

### 3.7.5 Transmitter Radiated Unwanted Emissions (Below 30MHz)

All amplitude of spurious emissions that are attenuated by more than 20 dB below the permissible value has no need to be reported.

### 3.7.6 Transmitter Radiated Unwanted Emissions

Refer as Appendix G



## 4 Test Equipment and Calibration Data

Instrument	Manufacturer	Model No.	Serial No.	Characteristics	Calibration Date	Calibration Due Date	Remark
EMI Receiver	Agilent	N9038A	My52260123	9kHz ~ 8.45GHz	Jan. 23, 2017	Jan. 22, 2018	Conduction (CO01-CB)
LISN	F.C.C.	FCC-LISN-50-1 6-2	04083	150kHz~100MHz	Dec. 14, 2016	Dec. 13, 2017	Conduction (CO01-CB)
LISN	Schwarzbeck	NSLK 8127	8127647	9kHz ~ 30MHz	Dec. 21, 2016	Dec. 20, 2017	Conduction (CO01-CB)
COND Cable	Woken	Cable	01	150kHz ~ 30MHz	May 23, 2017	May 22, 2018	Conduction (CO01-CB)
Software	Audix	E3	6.120210n	-	N.C.R.	N.C.R.	Conduction (CO01-CB)
BILOG ANTENNA with 6dB Attenuator	TESEQ & EMCI	CBL6112D & N-6-06	37880 & AT-N0609	20MHz ~ 2GHz	Aug. 30, 2017	Aug. 29, 2018	Radiation (03CH01-CB)
Loop Antenna	Teseq	HLA 6120	24155	9kHz - 30 MHz	Mar. 16, 2016*	Mar. 15, 2018*	Radiation (03CH01-CB)
Horn Antenna	EMCO	3115	00075790	750MHz~ 8GHz	Nov. 10, 2016	Nov. 09, 2017	Radiation (03CH01-CB)
Horn Antenna	Schwarzbeck	BBHA 9170	BBHA9170252	15GHz ~ 40GHz	Jul. 05, 2017	Jul. 04, 2018	Radiation (03CH01-CB)
Pre-Amplifier	EMCI	EMC330N	980332	20MHz ~ 3GHz	May 02, 2017	May 01, 2018	Radiation (03CH01-CB)
Pre-Amplifier	Agilent	8449B	3008A02310	1GHz ~ 26.5GHz	Jan. 16, 2017	Jan. 15, 2018	Radiation (03CH01-CB)
Pre-Amplifier	MITEQ	TTA1840-35-HG	1864479	18GHz ~ 40GHz	Jul. 10, 2017	Jul. 09, 2018	Radiation (03CH01-CB)
Spectrum Analyzer	R&S	FSP40	100056	9kHz ~ 40GHz	Nov. 22, 2016	Nov. 21, 2017	Radiation (03CH01-CB)
EMI Test	R&S	ESCS	100355	9kHz ~ 2.75GHz	May 06, 2017	May 05, 2018	Radiation (03CH01-CB)
RF Cable-low	Woken	Low Cable-16+17	N/A	30 MHz ~ 1 GHz	Oct. 24, 2016	Oct. 23, 2017	Radiation (03CH01-CB)
RF Cable-high	Woken	High Cable-16	N/A	1 GHz ~ 18 GHz	Oct. 24, 2016	Oct. 23, 2017	Radiation (03CH01-CB)
RF Cable-high	Woken	High Cable-16+17	N/A	1 GHz ~ 18 GHz	Oct. 24, 2016	Oct. 23, 2017	Radiation (03CH01-CB)
RF Cable-high	Woken	High Cable-40G#1	N/A	18GHz ~ 40 GHz	Oct. 24, 2016	Oct. 23, 2017	Radiation (03CH01-CB)
RF Cable-high	Woken	High Cable-40G#2	N/A	18GHz ~ 40 GHz	Oct. 24, 2016	Oct. 23, 2017	Radiation (03CH01-CB)
Test Software	Audix	E3	6.2009-10-7	N/A	N/A	N/A	Radiation (03CH01-CB)
Spectrum analyzer	R&S	FSV40	100979	9kHz~40GHz	Dec. 26, 2016	Dec. 25, 2017	Conducted (TH01-CB)



Instrument	Manufacturer	Model No.	Serial No.	Characteristics	Calibration Date	Calibration Due Date	Remark
RF Cable-high	Woken	RG402	High Cable-6	1 GHz –26.5 GHz	Oct. 24, 2016	Oct. 23, 2017	Conducted (TH01-CB)
RF Cable-high	Woken	RG402	High Cable-06	1 GHz –26.5 GHz	Oct. 11, 2017	Oct. 10, 2018	Conducted (TH01-CB)
RF Cable-high	Woken	RG402	High Cable-7	1 GHz –26.5 GHz	Oct. 24, 2016	Oct. 23, 2017	Conducted (TH01-CB)
RF Cable-high	Woken	RG402	High Cable-07	1 GHz –26.5 GHz	Oct. 11, 2017	Oct. 10, 2018	Conducted (TH01-CB)
RF Cable-high	Woken	RG402	High Cable-8	1 GHz –26.5 GHz	Oct. 24, 2016	Oct. 23, 2017	Conducted (TH01-CB)
RF Cable-high	Woken	RG402	High Cable-08	1 GHz –26.5 GHz	Oct. 11, 2017	Oct. 10, 2018	Conducted (TH01-CB)
RF Cable-high	Woken	RG402	High Cable-9	1 GHz –26.5 GHz	Oct. 24, 2016	Oct. 23, 2017	Conducted (TH01-CB)
RF Cable-high	Woken	RG402	High Cable-09	1 GHz –26.5 GHz	Oct. 11, 2017	Oct. 10, 2018	Conducted (TH01-CB)
RF Cable-high	Woken	RG402	High Cable-10	1 GHz –26.5 GHz	Oct. 24, 2016	Oct. 23, 2017	Conducted (TH01-CB)
RF Cable-high	Woken	RG402	High Cable-10	1 GHz –26.5 GHz	Oct. 11, 2017	Oct. 10, 2018	Conducted (TH01-CB)
Power Sensor	Agilent	U2021XA	MY53410001	50MHz~18GHz	Nov. 22, 2016	Nov. 21, 2017	Conducted (TH01-CB)

Note: Calibration Interval of instruments listed above is one year.

“\*\*” Calibration Interval of instruments listed above is two years.

N.C.R. means Non-Calibration required.



# AC Power-line Conducted Emissions Result

Appendix A

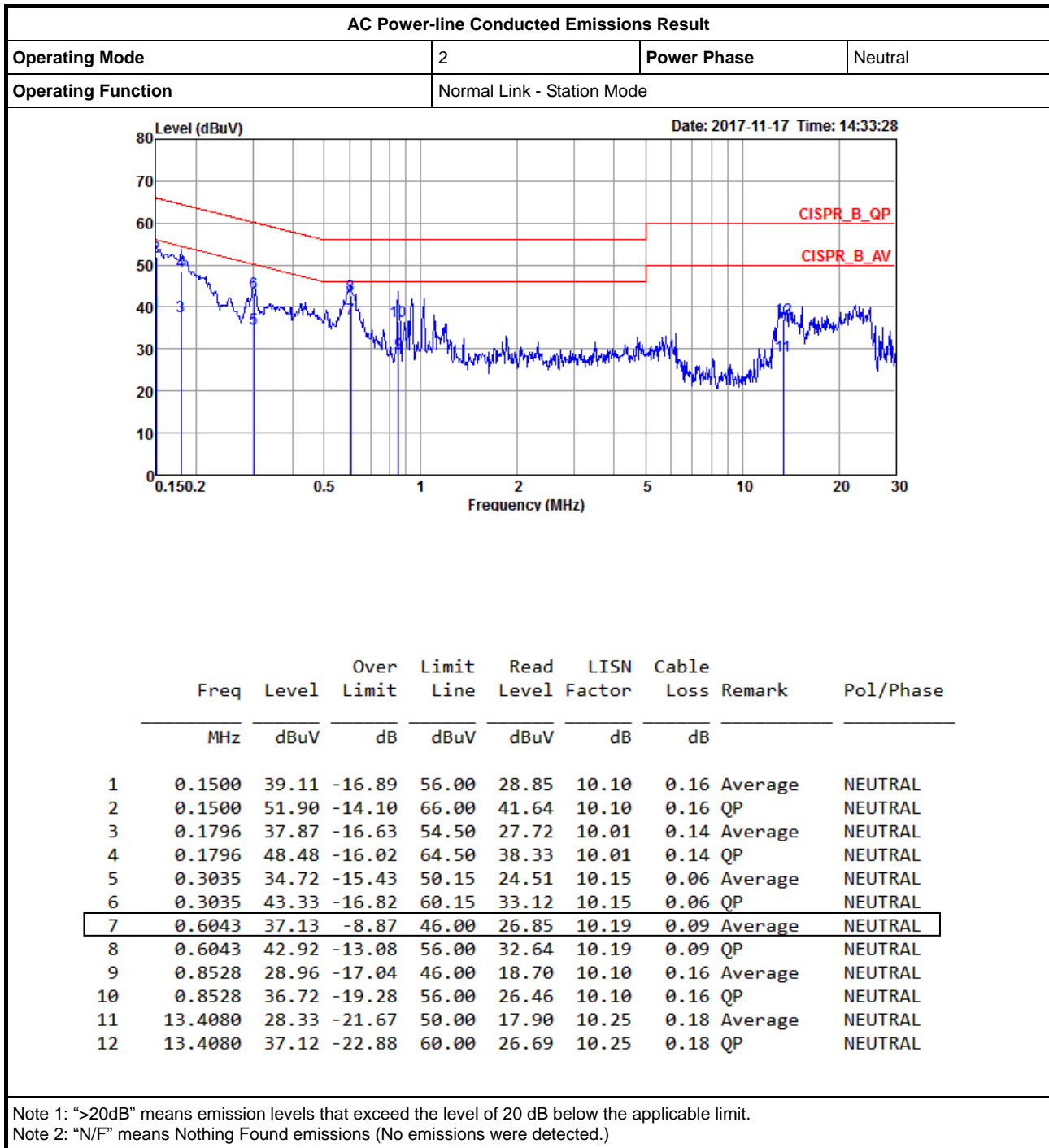



# AC Power-line Conducted Emissions Result

Appendix A

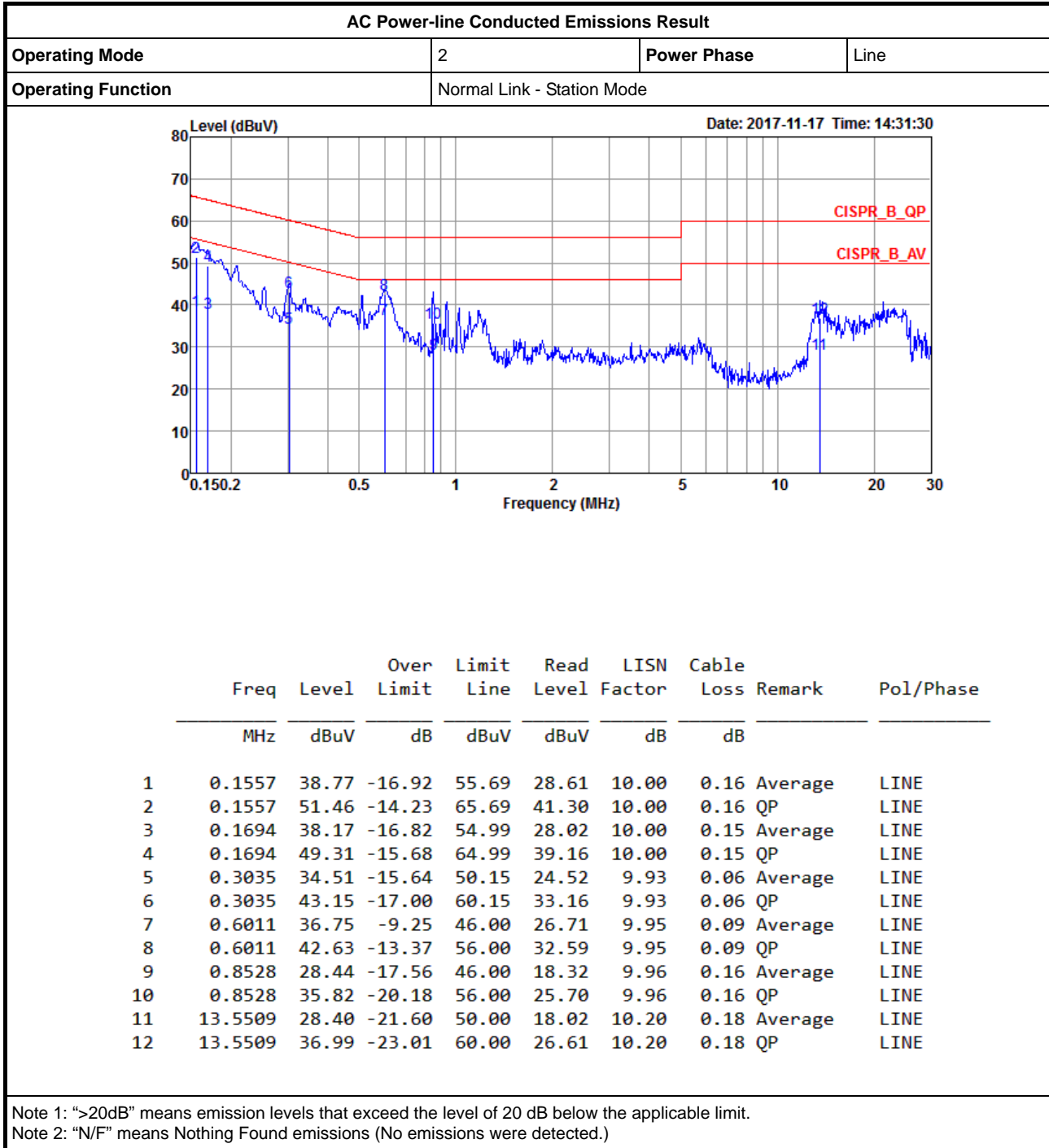



**Summary**

Mode	Max-N dB (Hz)	Max-OBW (Hz)	ITU-Code	Min-N dB (Hz)	Min-OBW (Hz)
2.4-2.4835GHz	-	-	-	-	-
BT-BR(1Mbps)	921.25k	872.064k	872KF1D	913.75k	852.074k
BT-EDR(2Mbps)	1.278M	1.284M	1M28G1D	1.264M	1.236M
BT-EDR(3Mbps)	1.274M	1.252M	1M25G1D	1.259M	1.229M

**Max-N dB** = Maximum 20dB down bandwidth; **Max-OBW** = Maximum 99% occupied bandwidth;  
**Min-N dB** = Minimum 20dB down bandwidth; **Min-OBW** = Minimum 99% occupied bandwidth;

**Result**

Mode	Result	Port 1-N dB (Hz)	Port 1-OBW (Hz)
BT-BR(1Mbps)	-	-	-
2402MHz	Pass	921.25k	872.064k
2440MHz	Pass	913.75k	852.074k
2480MHz	Pass	913.75k	857.071k
BT-EDR(2Mbps)	-	-	-
2402MHz	Pass	1.264M	1.236M
2440MHz	Pass	1.275M	1.269M
2480MHz	Pass	1.278M	1.284M
BT-EDR(3Mbps)	-	-	-
2402MHz	Pass	1.259M	1.229M
2440MHz	Pass	1.274M	1.243M
2480MHz	Pass	1.259M	1.252M

**Port X-N dB** = Port X 20dB down bandwidth; **Port X-OBW** = Port X 99% occupied bandwidth;



**Summary**

Mode	Max-Space (Hz)	Min-Space (Hz)
2.4-2.4835GHz	-	-
BT-BR(1Mbps)	1.0005M	999k
BT-EDR(2Mbps)	1.0035M	999k
BT-EDR(3Mbps)	1.002M	1.0005M

**Result**

Mode	Result	Fl (Hz)	Fh (Hz)	Ch.Space (Hz)	Limit (Hz)
BT-BR(1Mbps)	-	-	-	-	-
2402MHz	Pass	2.402002G	2.403003G	1.0005M	613.5525k
2440MHz	Pass	2.440001G	2.441G	999k	608.5575k
2480MHz	Pass	2.479001G	2.48G	999k	608.5575k
BT-EDR(2Mbps)	-	-	-	-	-
2402MHz	Pass	2.402002G	2.403006G	1.0035M	841.824k
2440MHz	Pass	2.440002G	2.441001G	999k	849.15k
2480MHz	Pass	2.479002G	2.480001G	999k	851.148k
BT-EDR(3Mbps)	-	-	-	-	-
2402MHz	Pass	2.402002G	2.403004G	1.002M	838.494k
2440MHz	Pass	2.440001G	2.441003G	1.002M	848.484k
2480MHz	Pass	2.479001G	2.480001G	1.0005M	838.494k





**Summary**

Mode	Power (dBm)	Power (W)
2.4-2.4835GHz	-	-
BT-BR(1Mbps)	9.64	0.00920
BT-EDR(2Mbps)	8.93	0.00782
BT-EDR(3Mbps)	8.58	0.00721

**Result**

Mode	Result	Gain (dBi)	Power (dBm)	Power Limit (dBm)
BT-BR(1Mbps)	-	-	-	-
2402MHz	Pass	2.02	9.19	21.00
2440MHz	Pass	2.02	9.61	21.00
2480MHz	Pass	2.02	9.64	21.00
BT-EDR(2Mbps)	-	-	-	-
2402MHz	Pass	2.02	7.50	21.00
2440MHz	Pass	2.02	8.38	21.00
2480MHz	Pass	2.02	8.93	21.00
BT-EDR(3Mbps)	-	-	-	-
2402MHz	Pass	2.02	7.45	21.00
2440MHz	Pass	2.02	8.38	21.00
2480MHz	Pass	2.02	8.58	21.00



**Summary**

Mode	Power (dBm)	Power (W)
2.4-2.4835GHz	-	-
BT-BR(1Mbps)	10.53	0.0113
BT-EDR(2Mbps)	10.67	0.01167
BT-EDR(3Mbps)	10.54	0.01132

**Result**

Mode	Result	Gain (dBi)	Power (dBm)	Power Limit (dBm)
BT-BR(1Mbps)	-	-	-	-
2402MHz	Pass	2.02	9.76	21.00
2440MHz	Pass	2.02	10.49	21.00
2480MHz	Pass	2.02	10.53	21.00
BT-EDR(2Mbps)	-	-	-	-
2402MHz	Pass	2.02	9.55	21.00
2440MHz	Pass	2.02	10.41	21.00
2480MHz	Pass	2.02	10.67	21.00
BT-EDR(3Mbps)	-	-	-	-
2402MHz	Pass	2.02	9.82	21.00
2440MHz	Pass	2.02	10.42	21.00
2480MHz	Pass	2.02	10.54	21.00



**Summary**

Mode	Max-Hop No
2.4-2.4835GHz	-
BT-BR(1Mbps)	79
BT-EDR(2Mbps)	79
BT-EDR(3Mbps)	79

**Result**

Mode	Result	Hopping No	Limit
BT-BR(1Mbps)	-	-	-
2440MHz	Pass	79	15
BT-EDR(2Mbps)	-	-	-
2440MHz	Pass	79	15
BT-EDR(3Mbps)	-	-	-
2440MHz	Pass	79	15



**Summary**

Mode	Max-Dwell (s)
2.4-2.4835GHz	-
BT-BR(1Mbps)	310.206m
BT-EDR(2Mbps)	311.3786m
BT-EDR(3Mbps)	311.4852m

**Result**

Mode	Result	Period (s)	Dwell (s)	Limit (s)	Tx On (s)
BT-BR(1Mbps)	-	-	-	-	-
2440MHz	Pass	31.6	310.206m	400m	2.91m
BT-EDR(2Mbps)	-	-	-	-	-
2440MHz	Pass	31.6	311.3786m	400m	2.921m
BT-EDR(3Mbps)	-	-	-	-	-
2440MHz	Pass	31.6	311.4852m	400m	2.922m



Summary

Mode	Result	Ref (Hz)	Ref (dBm)	Limit (dBm)	Freq (Hz)	Level (dBm)	Freq (Hz)	Level (dBm)	Freq (Hz)	Level (dBm)	Freq (Hz)	Level (dBm)	Port
2.4-2.4835GHz	-	-	-	-	-	-	-	-	-	-	-	-	-
BT-BR(1Mbps)	Pass	2.402004G	9.06	-10.94	2.194352G	-56.35	2.399992G	-32.48	2.484416G	-61.86	2.555858G	-43.57	1
BT-EDR(2Mbps)	Pass	2.401837G	8.07	-11.93	2.398G	-57.05	2.399996G	-33.78	2.483712G	-61.59	2.555858G	-46.38	1
BT-EDR(3Mbps)	Pass	2.402004G	8.32	-11.68	2.398G	-53.36	2.399992G	-33.70	2.484996G	-60.79	2.555858G	-45.13	1

Result

Mode	Result	Ref (Hz)	Ref (dBm)	Limit (dBm)	Freq (Hz)	Level (dBm)	Freq (Hz)	Level (dBm)	Freq (Hz)	Level (dBm)	Freq (Hz)	Level (dBm)	Port
BT-BR(1Mbps)	-	-	-	-	-	-	-	-	-	-	-	-	-
2402MHz	Pass	2.402004G	9.06	-10.94	2.194352G	-56.35	2.399992G	-32.48	2.484416G	-61.86	2.555858G	-43.57	1
2440MHz	Pass	2.44008G	10.30	-9.70	794.864M	-62.89	2.398472G	-62.44	2.484068G	-61.54	2.595258G	-43.54	1
2480MHz	Pass	2.479993G	9.32	-10.68	1.994256G	-62.35	2.398104G	-62.37	2.484G	-48.44	2.584001G	-52.02	1
BT-EDR(2Mbps)	-	-	-	-	-	-	-	-	-	-	-	-	-
2402MHz	Pass	2.401837G	8.07	-11.93	2.398G	-57.05	2.399996G	-33.78	2.483712G	-61.59	2.555858G	-46.38	1
2440MHz	Pass	2.44008G	7.52	-12.48	2.188432G	-61.73	2.399816G	-61.33	2.483916G	-61.18	2.595258G	-45.99	1
2480MHz	Pass	2.479659G	6.36	-13.64	645.68M	-62.20	2.398024G	-62.00	2.483532G	-44.00	2.634659G	-46.82	1
BT-EDR(3Mbps)	-	-	-	-	-	-	-	-	-	-	-	-	-
2402MHz	Pass	2.402004G	8.32	-11.68	2.398G	-53.36	2.399992G	-33.70	2.484996G	-60.79	2.555858G	-45.13	1
2440MHz	Pass	2.439913G	7.15	-12.85	908.528M	-61.95	2.399148G	-61.94	2.485104G	-60.85	2.595258G	-43.46	1
2480MHz	Pass	2.479993G	8.62	-11.38	735.664M	-61.63	2.398532G	-61.29	2.483508G	-46.85	2.634659G	-48.60	1

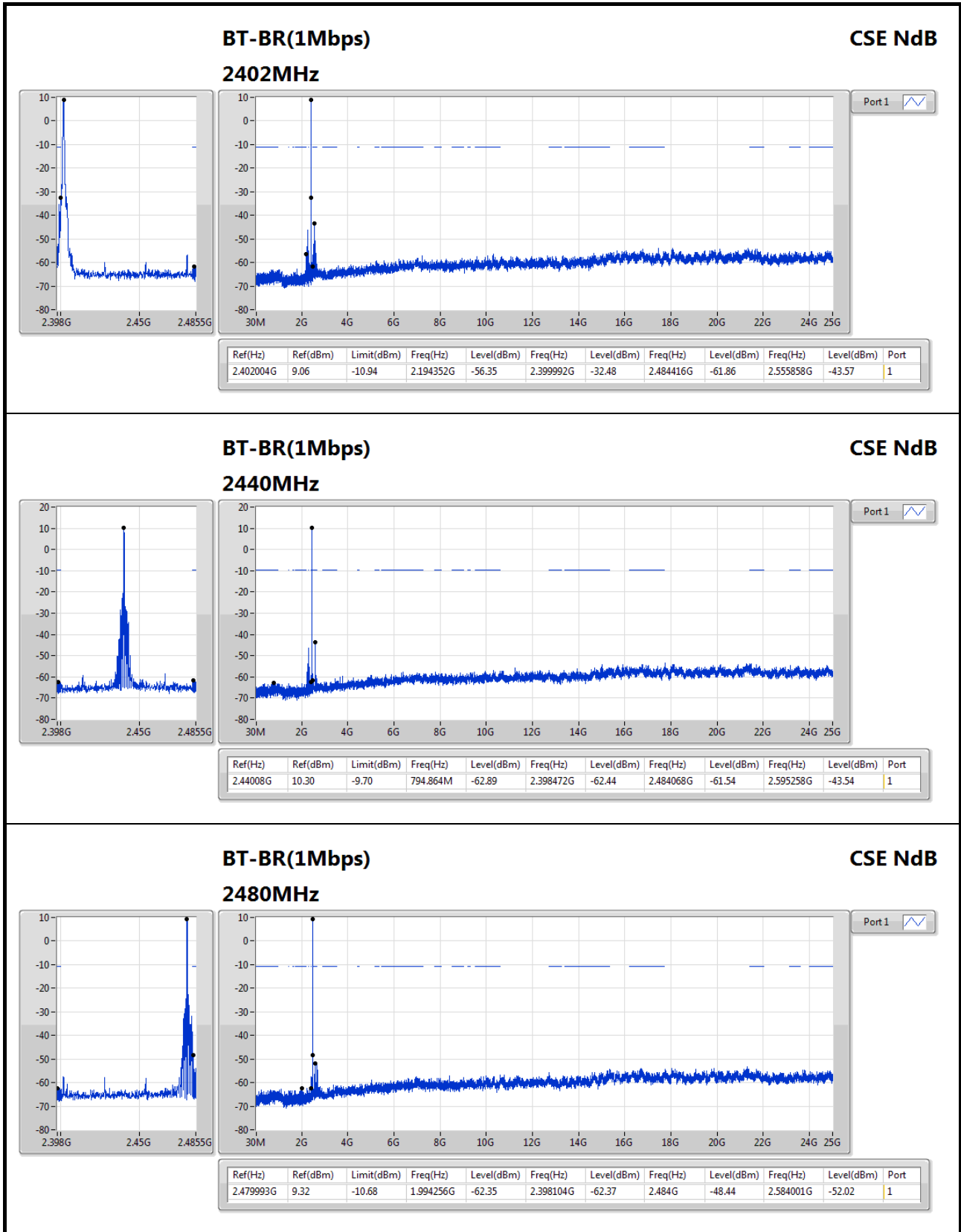

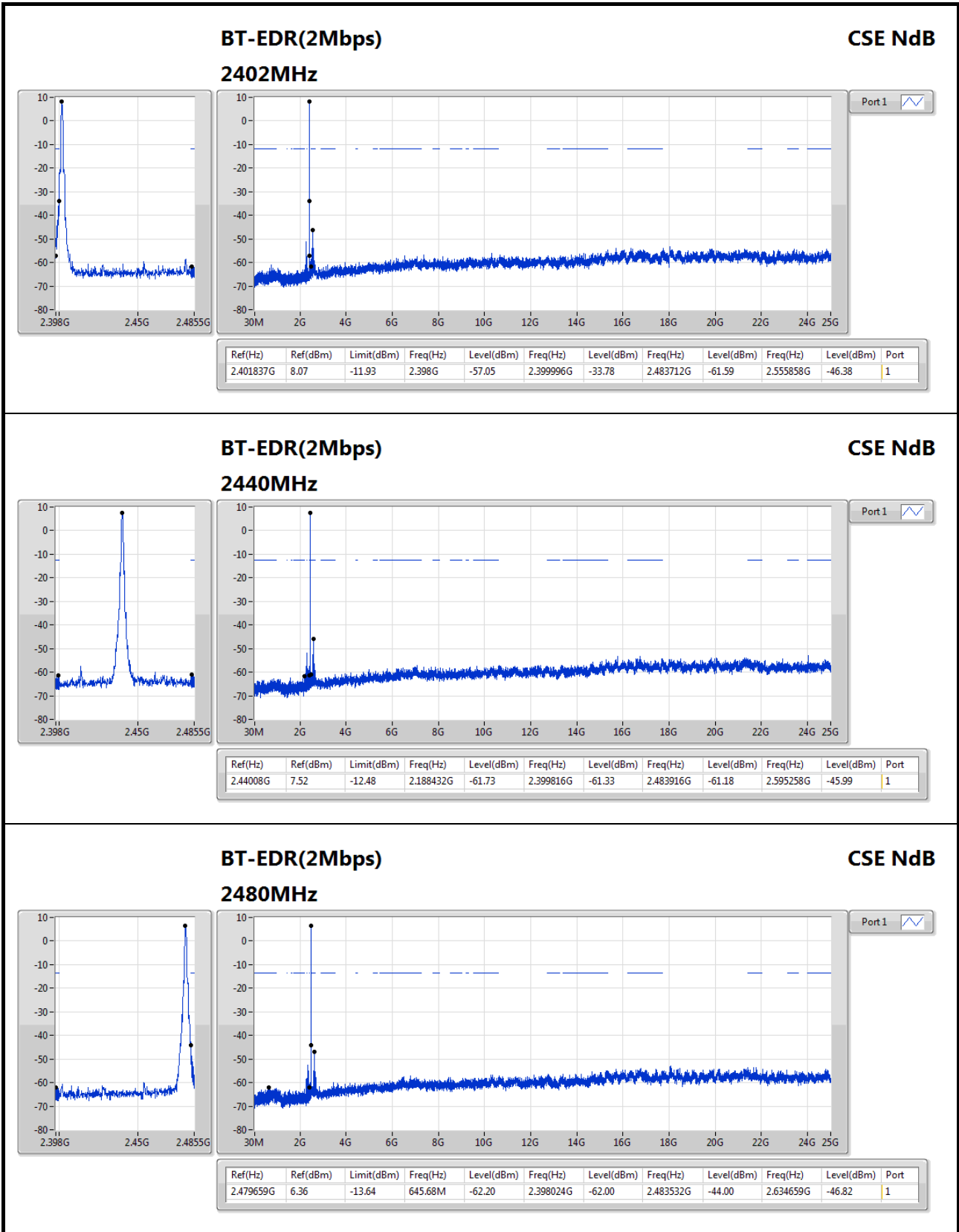

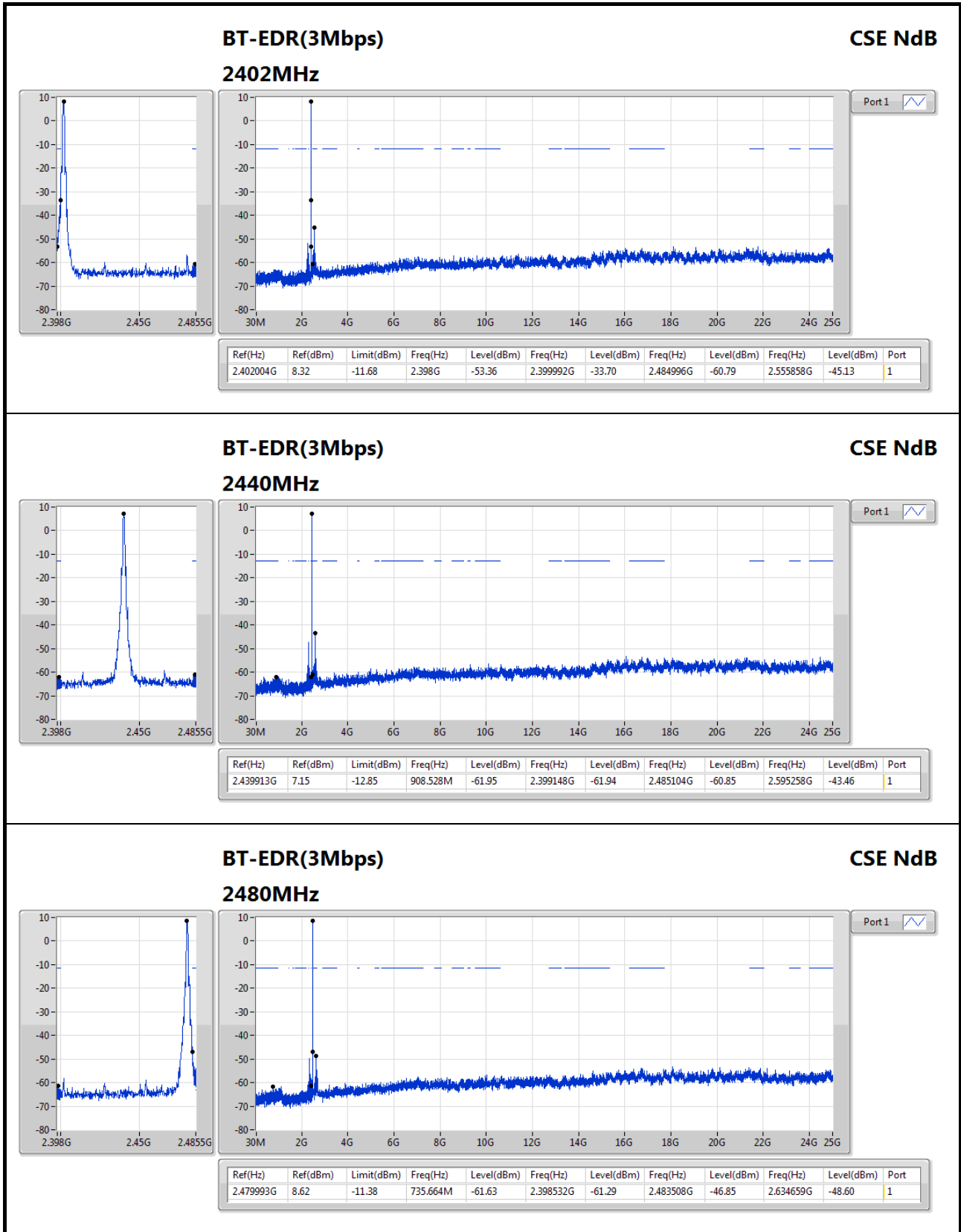





# RSE below 1GHz Result

Appendix G.1

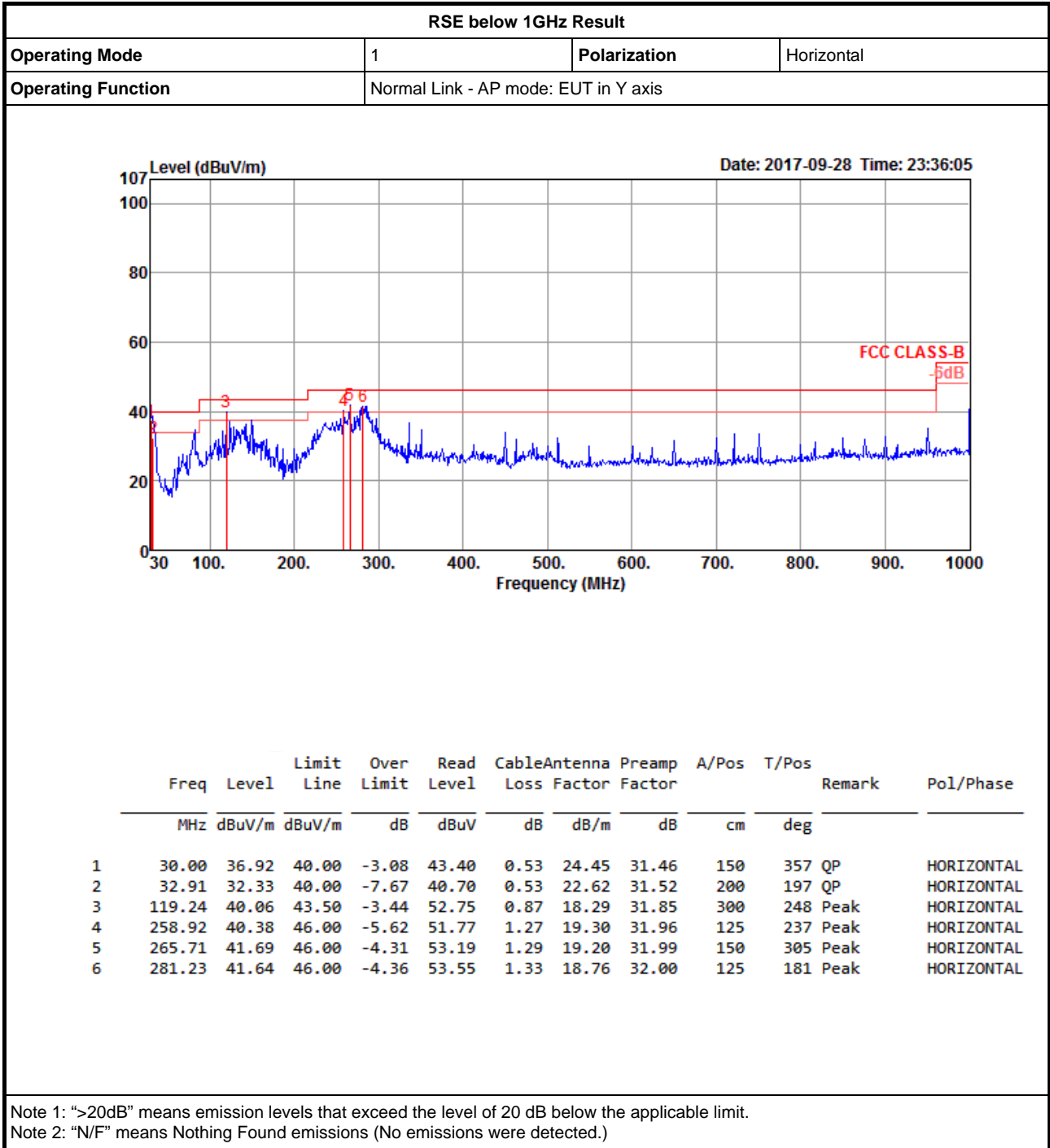



# RSE below 1GHz Result

Appendix G.1

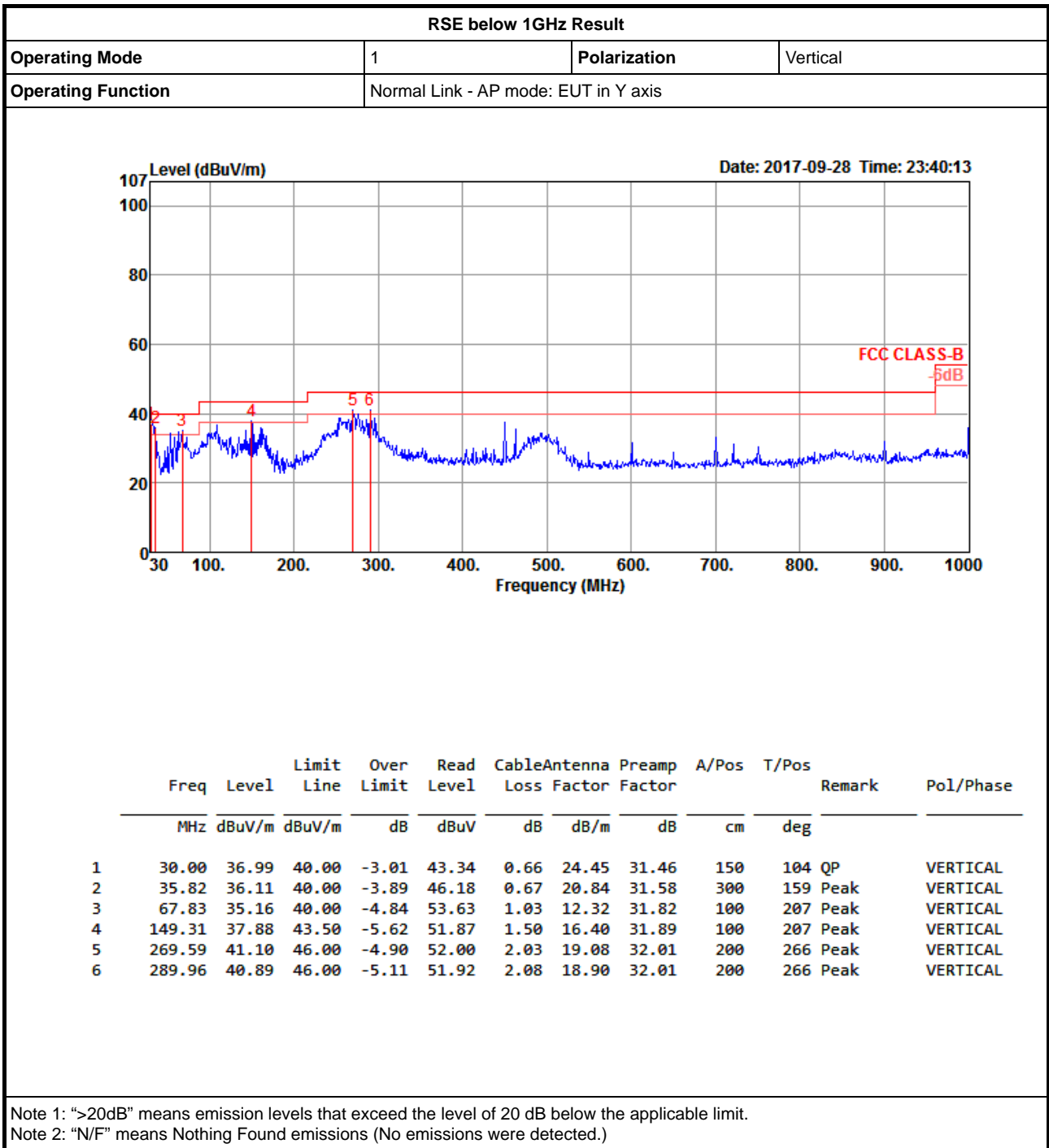



Summary

Mode	Result	Type	Freq (Hz)	Level (dBuV/m)	Limit (dBuV/m)	Margin (dB)	Factor (dB)	Dist (m)	Pol. (H/V)	Azimuth (°)	Height (m)	Comments
BT-BR(1Mbps)	-	-	-	-	-	-	-	-	-	-	-	-
2.4-2.4835GHz	Pass	AV	2.483502G	52.91	54.00	-1.09	30.86	3	H	6	1.41	-

### BT-BR(1Mbps)

### 2402MHz\_TX

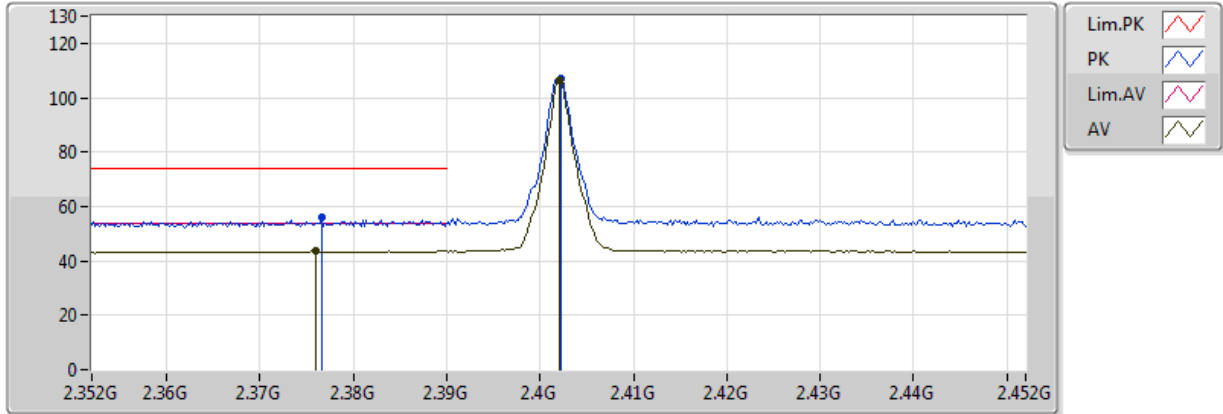

20171002  
EUT\_Z\_1TX  
Setting 63  
01-J-6  
FSP(100056)

Type	Freq(Hz)	Level(dBuV/m)	Limit(dBuV/m)	Margin(dB)	Factor(dB)	Dist(m)	Pol.(H/V)	Azimuth(°)	Height(m)	Comments
AV	2.376G	43.75	54.00	-10.25	30.97	3	V	70	1.12	-
AV	2.402G	106.40	Inf	-Inf	30.94	3	V	70	1.12	-
PK	2.3766G	56.31	74.00	-17.69	30.97	3	V	70	1.12	-
PK	2.4022G	107.25	Inf	-Inf	30.94	3	V	70	1.12	-

### BT-BR(1Mbps)

### 2402MHz\_TX

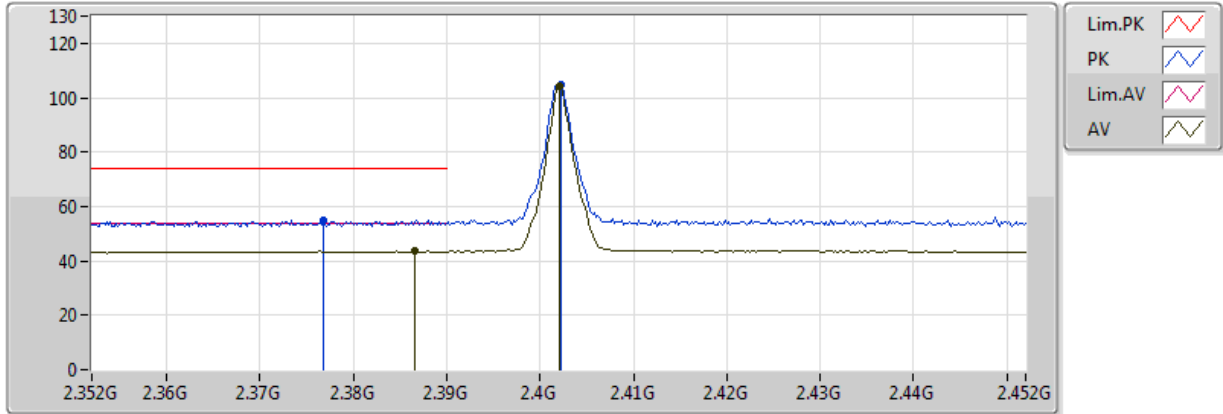

20171002  
EUT\_Z\_1TX  
Setting 63  
01-J-6  
FSP(100056)

Type	Freq(Hz)	Level(dBuV/m)	Limit(dBuV/m)	Margin(dB)	Factor(dB)	Dist(m)	Pol.(H/V)	Azimuth(°)	Height(m)	Comments
AV	2.3866G	43.54	54.00	-10.46	30.96	3	H	11	1.01	-
AV	2.402G	103.96	Inf	-Inf	30.94	3	H	11	1.01	-
PK	2.3768G	55.04	74.00	-18.96	30.97	3	H	11	1.01	-
PK	2.4022G	104.88	Inf	-Inf	30.94	3	H	11	1.01	-



### BT-BR(1Mbps)

### 2402MHz\_TX

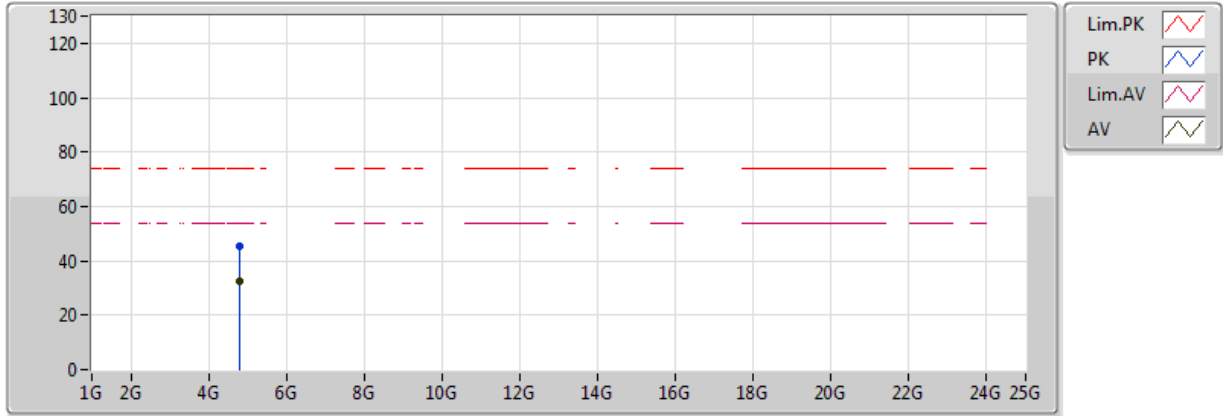

20171002  
 EUT\_Z\_1TX  
 Setting 63  
 01-M-1  
 FSP(100056)

Type	Freq(Hz)	Level(dBuV/m)	Limit(dBuV/m)	Margin(dB)	Factor(dB)	Dist(m)	Pol.(H/V)	Azimuth(°)	Height(m)	Comments
AV	4.80486G	32.30	54.00	-21.70	3.17	3	V	186	1.26	-
PK	4.80474G	45.51	74.00	-28.49	3.17	3	V	186	1.26	-



### BT-BR(1Mbps)

### 2402MHz\_TX

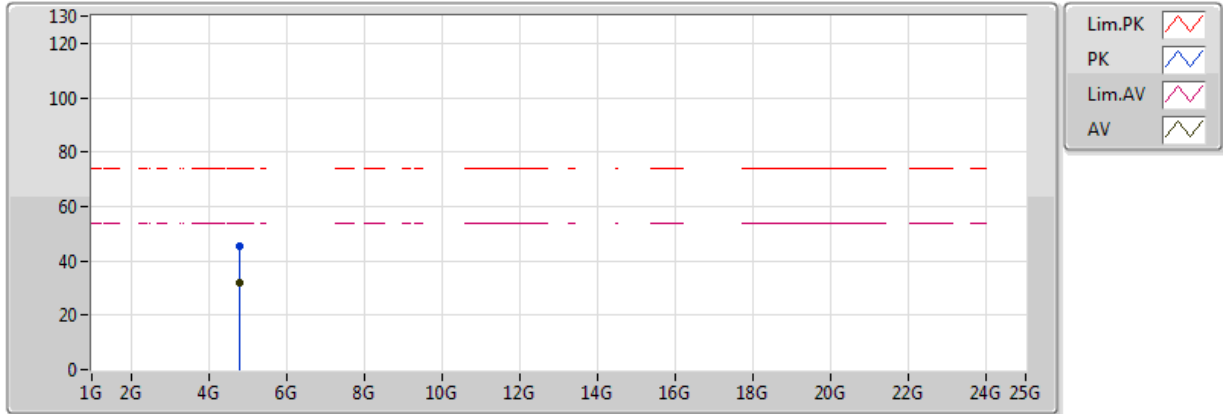

20171002  
 EUT\_Z\_1TX  
 Setting 63  
 01-M-1  
 FSP(100056)

Type	Freq(Hz)	Level(dBuV/m)	Limit(dBuV/m)	Margin(dB)	Factor(dB)	Dist(m)	Pol.(H/V)	Azimuth(°)	Height(m)	Comments
AV	4.80158G	32.02	54.00	-21.98	3.16	3	H	329	1.02	-
PK	4.8011G	45.46	74.00	-28.54	3.15	3	H	329	1.02	-

### BT-BR(1Mbps)

### 2440MHz\_TX

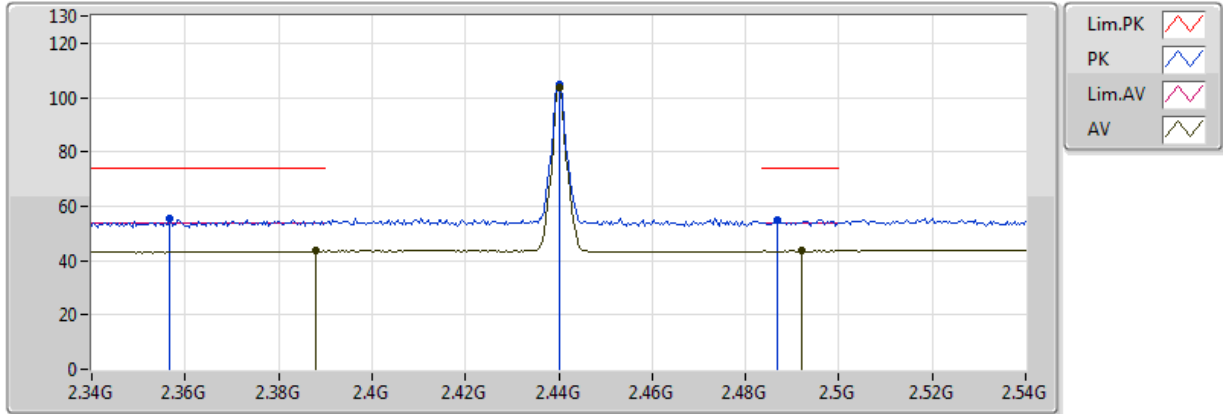

20171002  
 EUT\_Z\_1TX  
 Setting 63  
 01-M-1  
 FSP(100056)

Type	Freq(Hz)	Level(dBuV/m)	Limit(dBuV/m)	Margin(dB)	Factor(dB)	Dist(m)	Pol.(H/V)	Azimuth(°)	Height(m)	Comments
AV	2.388G	43.83	54.00	-10.17	30.96	3	V	68	1.36	-
AV	2.44G	103.61	Inf	-Inf	30.90	3	V	68	1.36	-
AV	2.492G	43.58	54.00	-10.42	30.86	3	V	68	1.36	-
PK	2.3568G	55.39	74.00	-18.61	31.00	3	V	68	1.36	-
PK	2.44G	104.51	Inf	-Inf	30.90	3	V	68	1.36	-
PK	2.4868G	55.04	74.00	-18.96	30.86	3	V	68	1.36	-



### BT-BR(1Mbps)

### 2440MHz\_TX

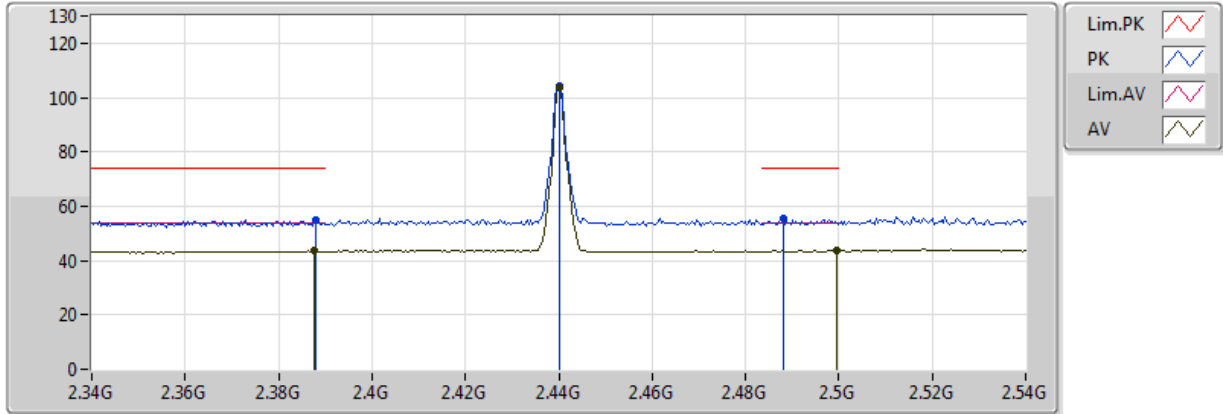

20171002  
 EUT\_Z\_1TX  
 Setting 63  
 01-M-1  
 FSP(100056)

Type	Freq(Hz)	Level(dBuV/m)	Limit(dBuV/m)	Margin(dB)	Factor(dB)	Dist(m)	Pol.(H/V)	Azimuth(°)	Height(m)	Comments
AV	2.3876G	43.56	54.00	-10.44	30.96	3	H	4	1.39	-
AV	2.44G	103.40	Inf	-Inf	30.90	3	H	4	1.39	-
AV	2.4996G	43.98	54.00	-10.02	30.85	3	H	4	1.39	-
PK	2.388G	55.01	74.00	-18.99	30.96	3	H	4	1.39	-
PK	2.44G	104.29	Inf	-Inf	30.90	3	H	4	1.39	-
PK	2.488G	55.45	74.00	-18.55	30.86	3	H	4	1.39	-



### BT-BR(1Mbps)

### 2440MHz\_TX

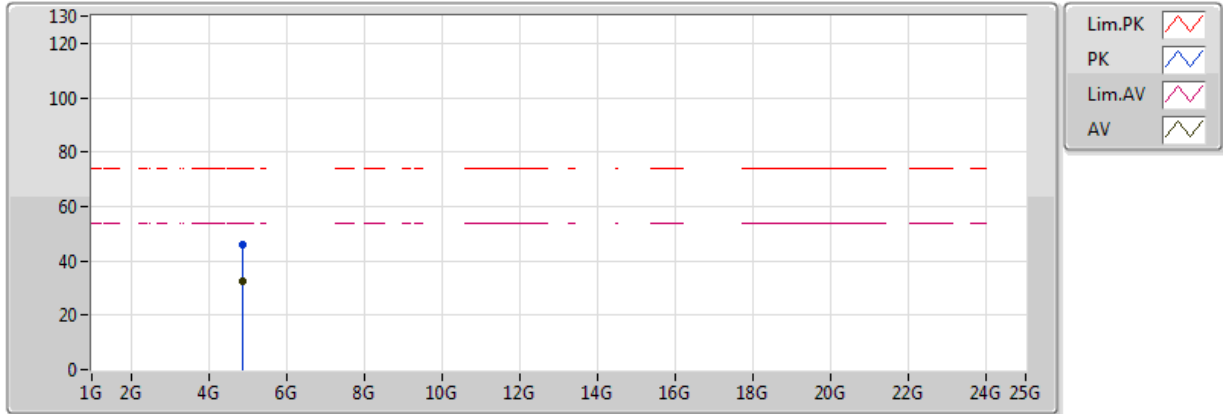

20171002  
 EUT\_Z\_1TX  
 Setting 63  
 01-M-1  
 FSP(100056)

Type	Freq(Hz)	Level(dBuV/m)	Limit(dBuV/m)	Margin(dB)	Factor(dB)	Dist(m)	Pol.(H/V)	Azimuth(°)	Height(m)	Comments
AV	4.8805G	32.40	54.00	-21.60	3.41	3	V	41	1.50	-
PK	4.88032G	45.94	74.00	-28.06	3.41	3	V	41	1.50	-



### BT-BR(1Mbps)

### 2440MHz\_TX

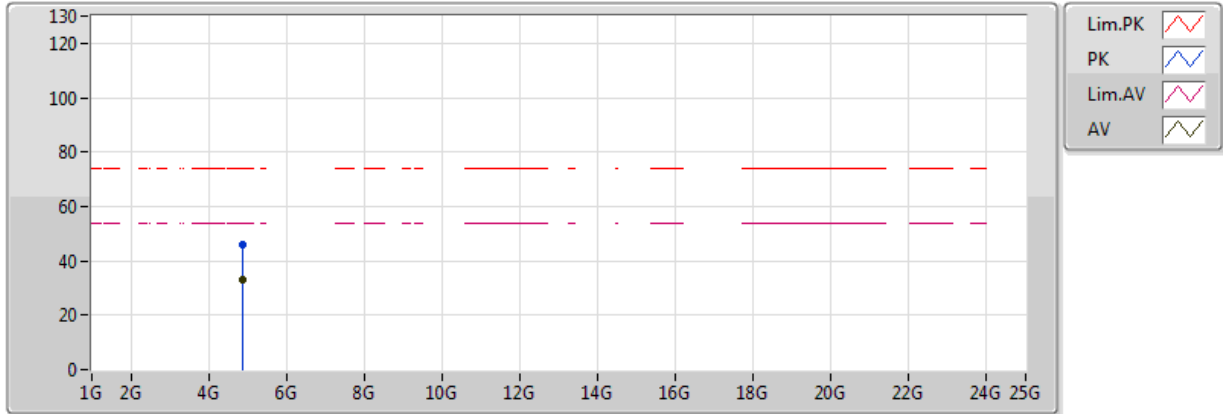

20171002  
 EUT\_Z\_1TX  
 Setting 63  
 01-M-1  
 FSP(100056)

Type	Freq(Hz)	Level(dBuV/m)	Limit(dBuV/m)	Margin(dB)	Factor(dB)	Dist(m)	Pol.(H/V)	Azimuth(°)	Height(m)	Comments
AV	4.88498G	32.89	54.00	-21.11	3.42	3	H	147	1.50	-
PK	4.88332G	46.17	74.00	-27.83	3.42	3	H	147	1.50	-

### BT-BR(1Mbps)

### 2480MHz\_TX

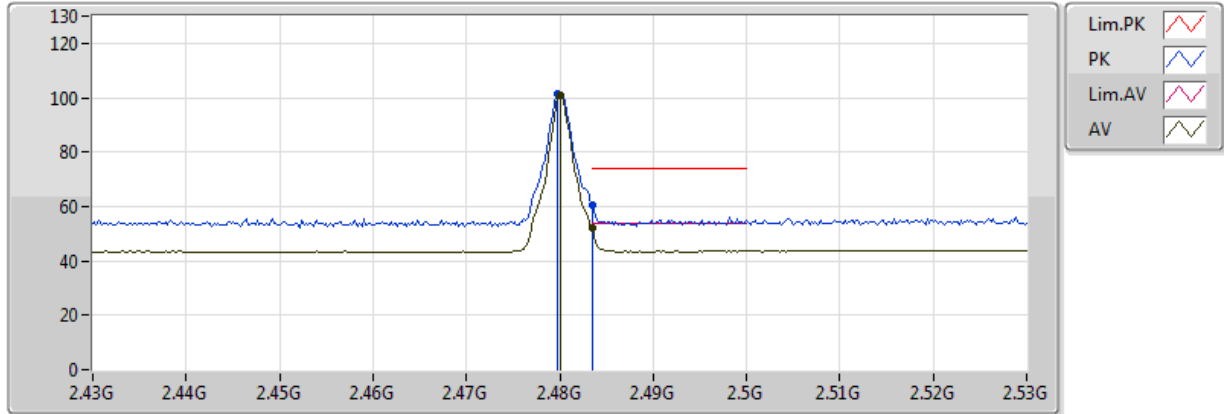

20171002  
EUT\_Z\_1TX  
Setting 55  
01-M-1  
FSP(100056)

Type	Freq(Hz)	Level(dBuV/m)	Limit(dBuV/m)	Margin(dB)	Factor(dB)	Dist(m)	Pol.(H/V)	Azimuth(°)	Height(m)	Comments
AV	2.48G	100.81	Inf	-Inf	30.87	3	V	71	1.50	-
AV	2.483502G	51.85	54.00	-2.15	30.86	3	V	71	1.50	-
PK	2.4798G	101.69	Inf	-Inf	30.87	3	V	71	1.50	-
PK	2.483502G	60.76	74.00	-13.24	30.86	3	V	71	1.50	-

### BT-BR(1Mbps)

### 2480MHz\_TX

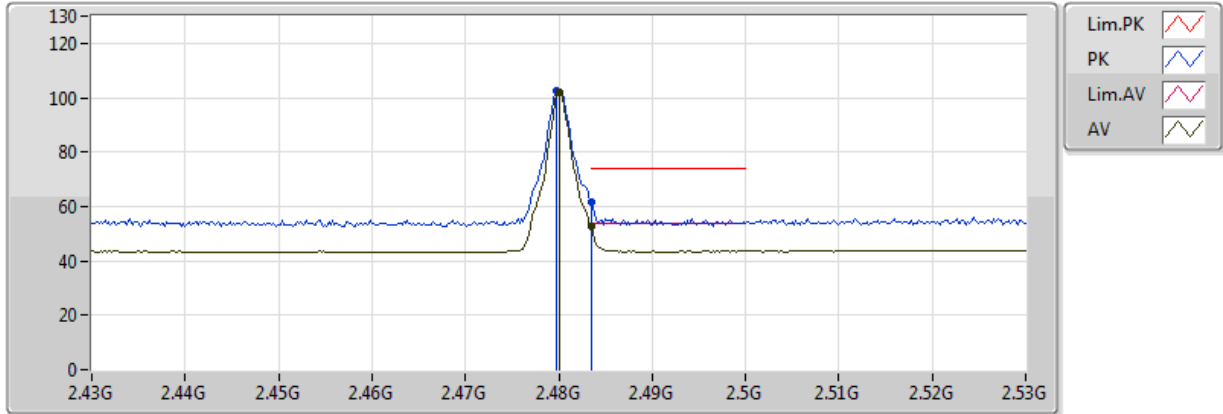

20171002  
EUT\_Z\_1TX  
Setting 55  
01-M-1  
FSP(100056)

Type	Freq(Hz)	Level(dBuV/m)	Limit(dBuV/m)	Margin(dB)	Factor(dB)	Dist(m)	Pol.(H/V)	Azimuth(°)	Height(m)	Comments
AV	2.48G	101.83	Inf	-Inf	30.87	3	H	6	1.41	-
AV	2.483502G	52.91	54.00	-1.09	30.86	3	H	6	1.41	-
PK	2.4798G	102.75	Inf	-Inf	30.87	3	H	6	1.41	-
PK	2.483502G	61.87	74.00	-12.13	30.86	3	H	6	1.41	-

### BT-BR(1Mbps)

### 2480MHz\_TX

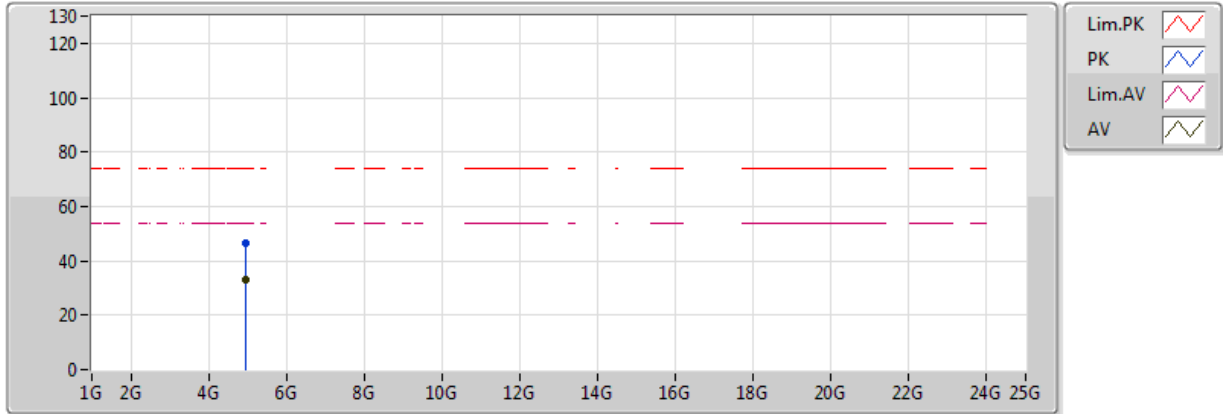

20171002  
 EUT\_Z\_1TX  
 Setting 55  
 01-M-1  
 FSP(100056)

Type	Freq(Hz)	Level(dBuV/m)	Limit(dBuV/m)	Margin(dB)	Factor(dB)	Dist(m)	Pol.(H/V)	Azimuth(°)	Height(m)	Comments
AV	4.9646G	32.80	54.00	-21.20	3.69	3	V	337	2.37	-
PK	4.96346G	46.52	74.00	-27.48	3.69	3	V	337	2.37	-

### BT-BR(1Mbps)

### 2480MHz\_TX

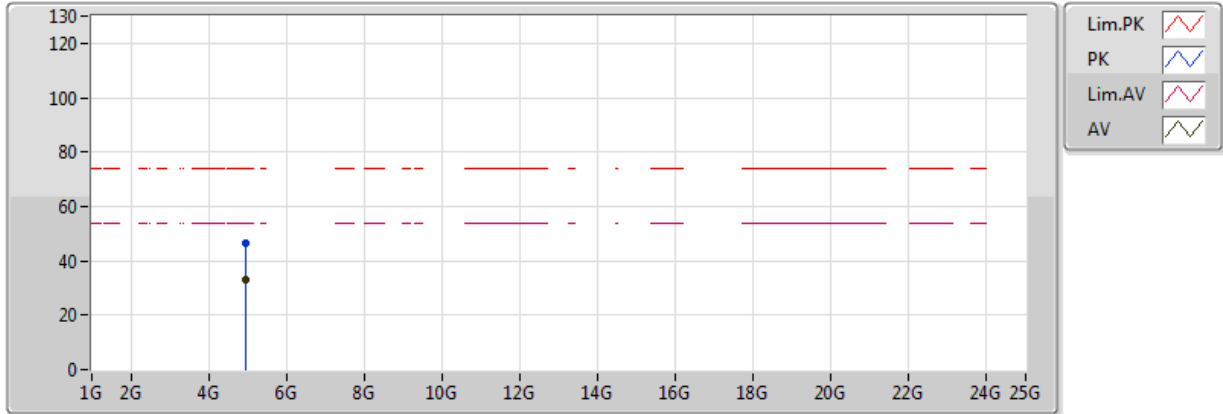

20171002  
 EUT\_Z\_1TX  
 Setting 55  
 01-M-1  
 FSP(100056)

Type	Freq(Hz)	Level(dBuV/m)	Limit(dBuV/m)	Margin(dB)	Factor(dB)	Dist(m)	Pol.(H/V)	Azimuth(°)	Height(m)	Comments
AV	4.96242G	32.84	54.00	-21.16	3.68	3	H	127	1.56	-
PK	4.95824G	46.47	74.00	-27.53	3.67	3	H	127	1.56	-

### BT-EDR(3Mbps)

### 2402MHz\_TX

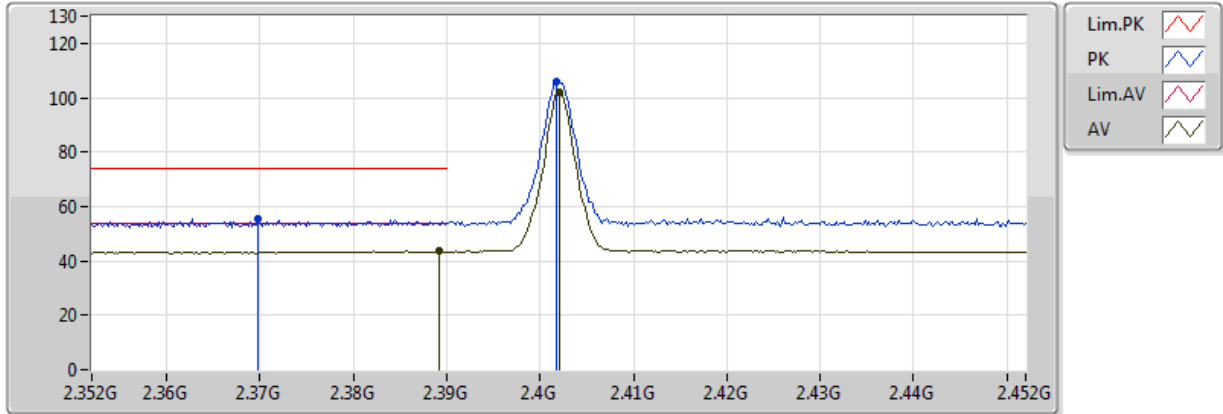

20171002  
 EUT\_Z\_1TX  
 Setting 63  
 01-M-1  
 FSP(100056)

Type	Freq(Hz)	Level(dBuV/m)	Limit(dBuV/m)	Margin(dB)	Factor(dB)	Dist(m)	Pol.(H/V)	Azimuth(°)	Height(m)	Comments
AV	2.3892G	43.52	54.00	-10.48	30.95	3	V	69	1.12	-
AV	2.402G	101.80	Inf	-Inf	30.94	3	V	69	1.12	-
PK	2.3698G	55.41	74.00	-18.59	30.98	3	V	69	1.12	-
PK	2.4018G	105.73	Inf	-Inf	30.94	3	V	69	1.12	-



### BT-EDR(3Mbps)

### 2402MHz\_TX

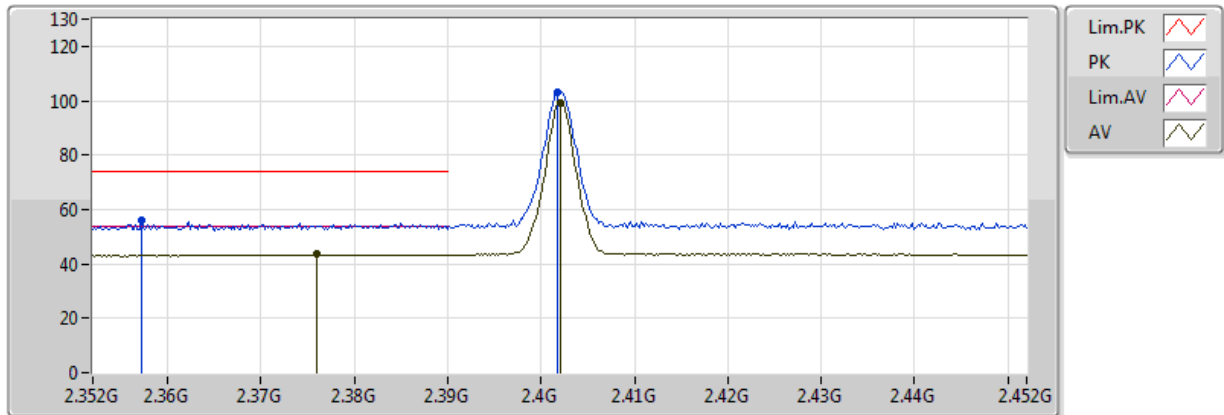

20171002  
EUT\_Z\_1TX  
Setting 63  
01-M-1  
FSP(100056)

Type	Freq(Hz)	Level(dBuV/m)	Limit(dBuV/m)	Margin(dB)	Factor(dB)	Dist(m)	Pol.(H/V)	Azimuth(°)	Height(m)	Comments
AV	2.376G	43.43	54.00	-10.57	30.97	3	H	11	1.01	-
AV	2.402G	99.18	Inf	-Inf	30.94	3	H	11	1.01	-
PK	2.3572G	56.11	74.00	-17.89	31.00	3	H	11	1.01	-
PK	2.4018G	103.05	Inf	-Inf	30.94	3	H	11	1.01	-

### BT-EDR(3Mbps)

### 2402MHz\_TX

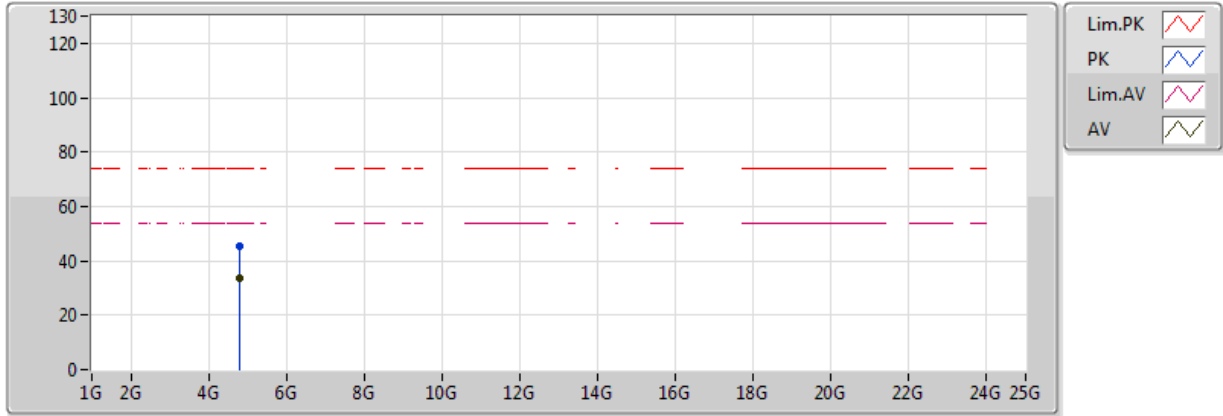

20171002  
EUT\_Z\_1TX  
Setting 63  
01-M-1  
FSP(100056)

Type	Freq(Hz)	Level(dBuV/m)	Limit(dBuV/m)	Margin(dB)	Factor(dB)	Dist(m)	Pol.(H/V)	Azimuth(°)	Height(m)	Comments
AV	4.8069G	33.35	54.00	-20.65	3.17	3	V	57	1.20	-
PK	4.80272G	45.32	74.00	-28.68	3.16	3	V	57	1.20	-



### BT-EDR(3Mbps)

### 2402MHz\_TX

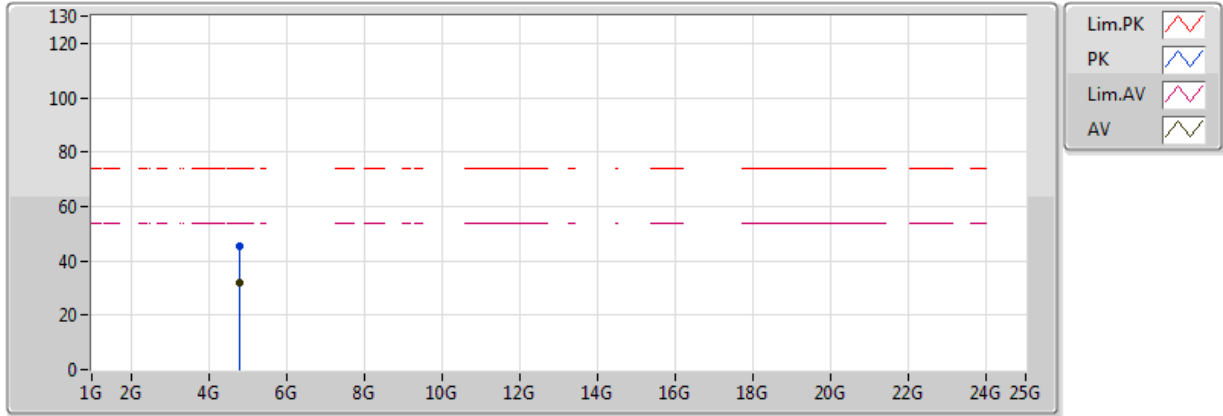

20171002  
 EUT\_Z\_1TX  
 Setting 63  
 01-M-1  
 FSP(100056)

Type	Freq(Hz)	Level(dBuV/m)	Limit(dBuV/m)	Margin(dB)	Factor(dB)	Dist(m)	Pol.(H/V)	Azimuth(°)	Height(m)	Comments
AV	4.80302G	31.93	54.00	-22.07	3.16	3	H	57	1.66	-
PK	4.80326G	45.65	74.00	-28.35	3.16	3	H	57	1.66	-

### BT-EDR(3Mbps)

### 2440MHz\_TX

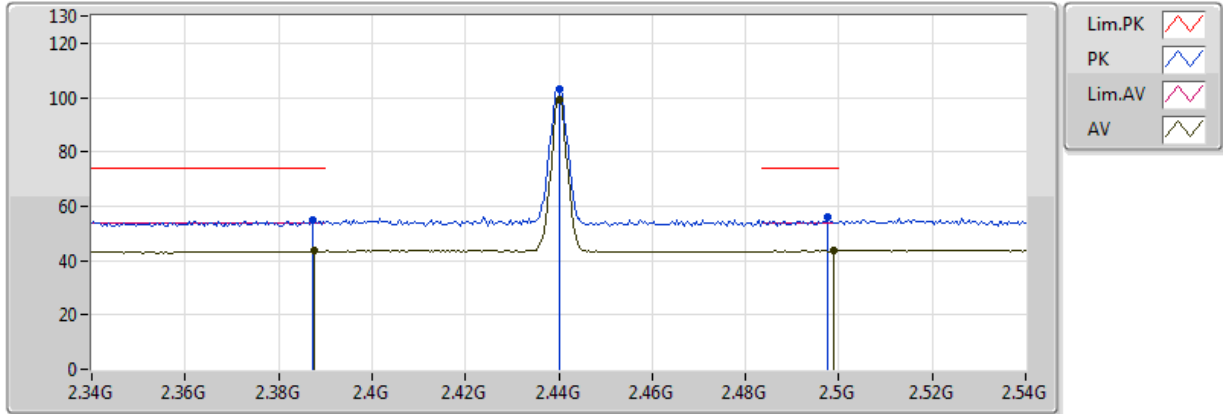

20171002  
EUT\_Z\_1TX  
Setting 63  
01-M-1  
FSP(100056)

Type	Freq(Hz)	Level(dBuV/m)	Limit(dBuV/m)	Margin(dB)	Factor(dB)	Dist(m)	Pol.(H/V)	Azimuth(°)	Height(m)	Comments
AV	2.3876G	43.47	54.00	-10.53	30.96	3	V	69	1.50	-
AV	2.44G	99.43	Inf	-Inf	30.90	3	V	69	1.50	-
AV	2.4988G	43.70	54.00	-10.30	30.85	3	V	69	1.50	-
PK	2.3872G	54.89	74.00	-19.11	30.96	3	V	69	1.50	-
PK	2.44G	103.10	Inf	-Inf	30.90	3	V	69	1.50	-
PK	2.4976G	55.85	74.00	-18.15	30.85	3	V	69	1.50	-

### BT-EDR(3Mbps)

### 2440MHz\_TX

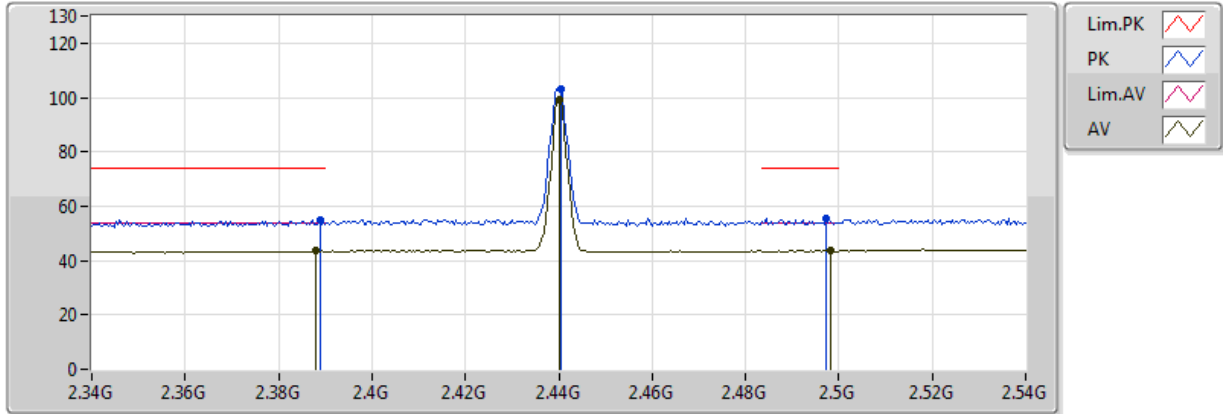

20171002  
EUT\_Z\_1TX  
Setting 63  
01-M-1  
FSP(100056)

Type	Freq(Hz)	Level(dBuV/m)	Limit(dBuV/m)	Margin(dB)	Factor(dB)	Dist(m)	Pol.(H/V)	Azimuth(°)	Height(m)	Comments
AV	2.388G	43.52	54.00	-10.48	30.96	3	H	5	1.38	-
AV	2.44G	99.44	Inf	-Inf	30.90	3	H	5	1.38	-
AV	2.4984G	43.71	54.00	-10.29	30.85	3	H	5	1.38	-
PK	2.3888G	55.16	74.00	-18.84	30.95	3	H	5	1.38	-
PK	2.4404G	103.11	Inf	-Inf	30.90	3	H	5	1.38	-
PK	2.4972G	55.40	74.00	-18.60	30.85	3	H	5	1.38	-



### BT-EDR(3Mbps)

### 2440MHz\_TX

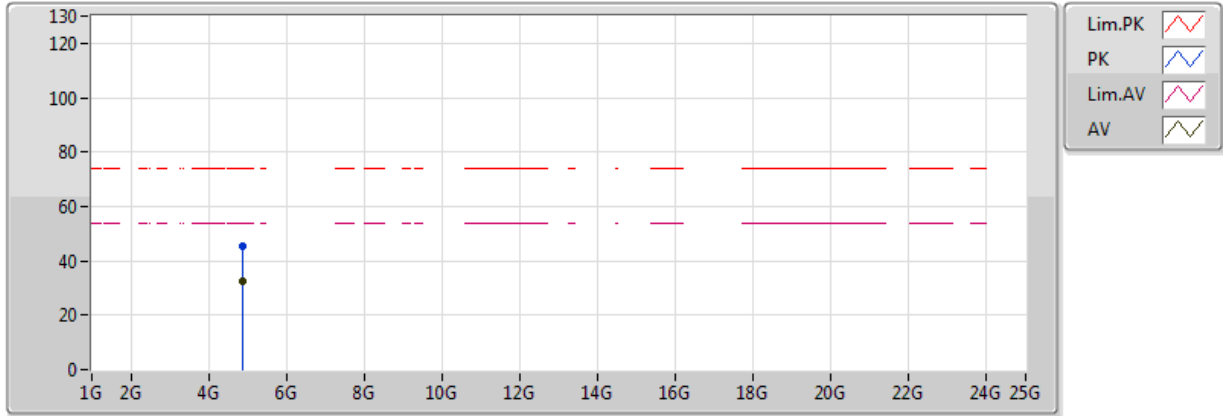

20171002  
 EUT\_Z\_1TX  
 Setting 63  
 01-M-1  
 FSP(100056)

Type	Freq(Hz)	Level(dBuV/m)	Limit(dBuV/m)	Margin(dB)	Factor(dB)	Dist(m)	Pol.(H/V)	Azimuth(°)	Height(m)	Comments
AV	4.88362G	32.45	54.00	-21.55	3.42	3	V	70	1.66	-
PK	4.8839G	45.50	74.00	-28.50	3.42	3	V	70	1.66	-

### BT-EDR(3Mbps)

### 2440MHz\_TX

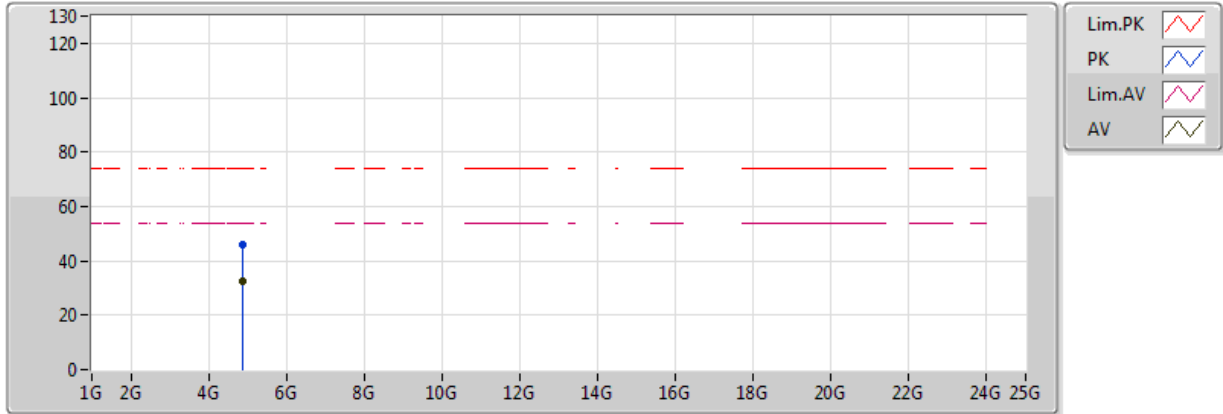

20171002  
 EUT\_Z\_1TX  
 Setting 63  
 01-M-1  
 FSP(100056)

Type	Freq(Hz)	Level(dBuV/m)	Limit(dBuV/m)	Margin(dB)	Factor(dB)	Dist(m)	Pol.(H/V)	Azimuth(°)	Height(m)	Comments
AV	4.8848G	32.42	54.00	-21.58	3.42	3	H	248	1.10	-
PK	4.88348G	45.98	74.00	-28.02	3.42	3	H	248	1.10	-

### BT-EDR(3Mbps)

### 2480MHz\_TX

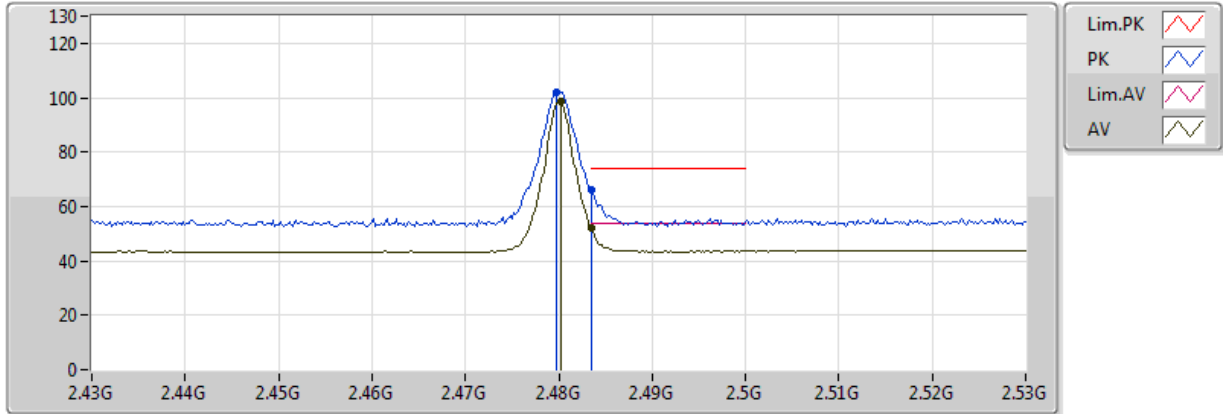

20171002  
EUT\_Z\_1TX  
Setting 61  
01-M-1  
FSP(100056)

Type	Freq(Hz)	Level(dBuV/m)	Limit(dBuV/m)	Margin(dB)	Factor(dB)	Dist(m)	Pol.(H/V)	Azimuth(°)	Height(m)	Comments
AV	2.4802G	98.54	Inf	-Inf	30.87	3	V	69	1.05	-
AV	2.483502G	52.39	54.00	-1.61	30.86	3	V	69	1.05	-
PK	2.4798G	102.14	Inf	-Inf	30.87	3	V	69	1.05	-
PK	2.483502G	66.26	74.00	-7.74	30.86	3	V	69	1.05	-



### BT-EDR(3Mbps)

### 2480MHz\_TX

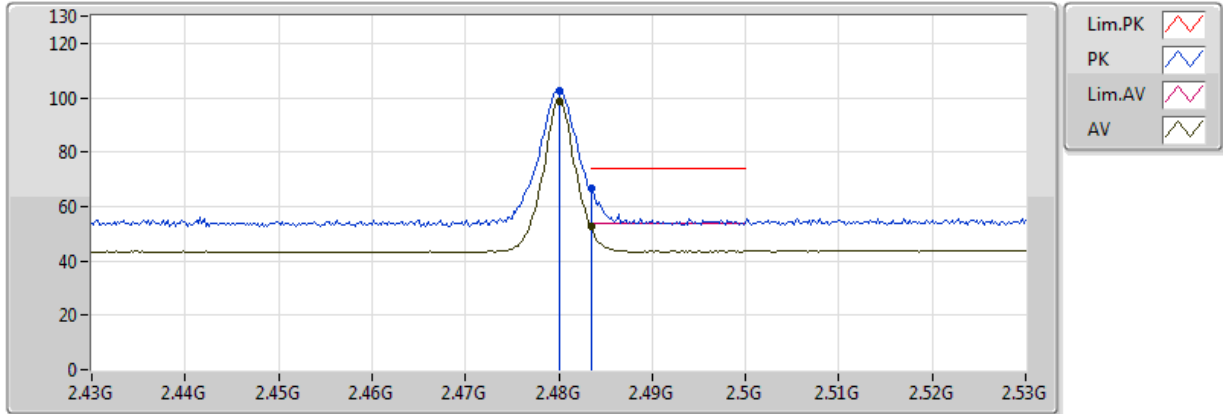

20171002  
EUT\_Z\_1TX  
Setting 61  
01-M-1  
FSP(100056)

Type	Freq(Hz)	Level(dBuV/m)	Limit(dBuV/m)	Margin(dB)	Factor(dB)	Dist(m)	Pol.(H/V)	Azimuth(°)	Height(m)	Comments
AV	2.48G	98.77	Inf	-Inf	30.87	3	H	0	1.58	-
AV	2.483502G	52.63	54.00	-1.37	30.86	3	H	0	1.58	-
PK	2.48G	102.29	Inf	-Inf	30.87	3	H	0	1.58	-
PK	2.483502G	66.95	74.00	-7.05	30.86	3	H	0	1.58	-

### BT-EDR(3Mbps)

### 2480MHz\_TX

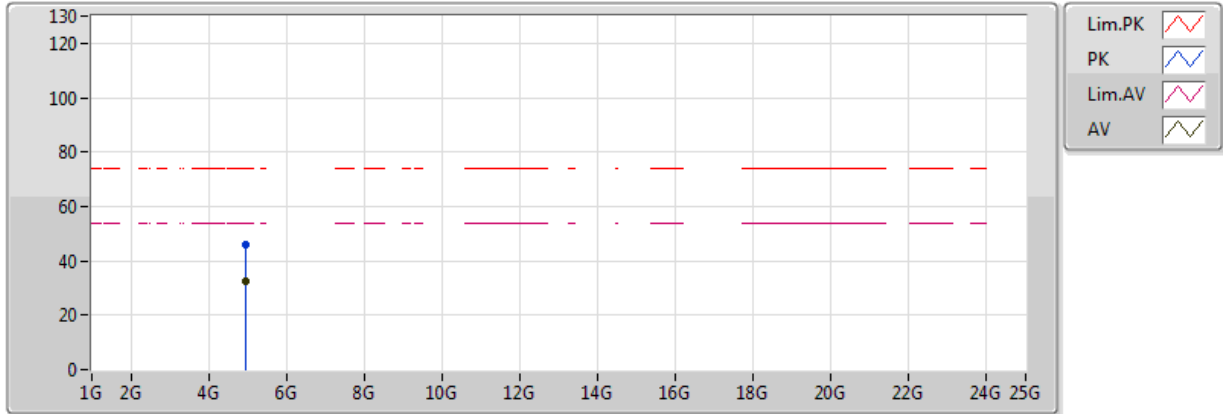

20171002  
EUT\_Z\_1TX  
Setting 61  
01-M-1  
FSP(100056)

Type	Freq(Hz)	Level(dBuV/m)	Limit(dBuV/m)	Margin(dB)	Factor(dB)	Dist(m)	Pol.(H/V)	Azimuth(°)	Height(m)	Comments
AV	4.965G	32.66	54.00	-21.34	3.69	3	V	356	2.17	-
PK	4.96212G	45.83	74.00	-28.17	3.68	3	V	356	2.17	-

### BT-EDR(3Mbps)

### 2480MHz\_TX

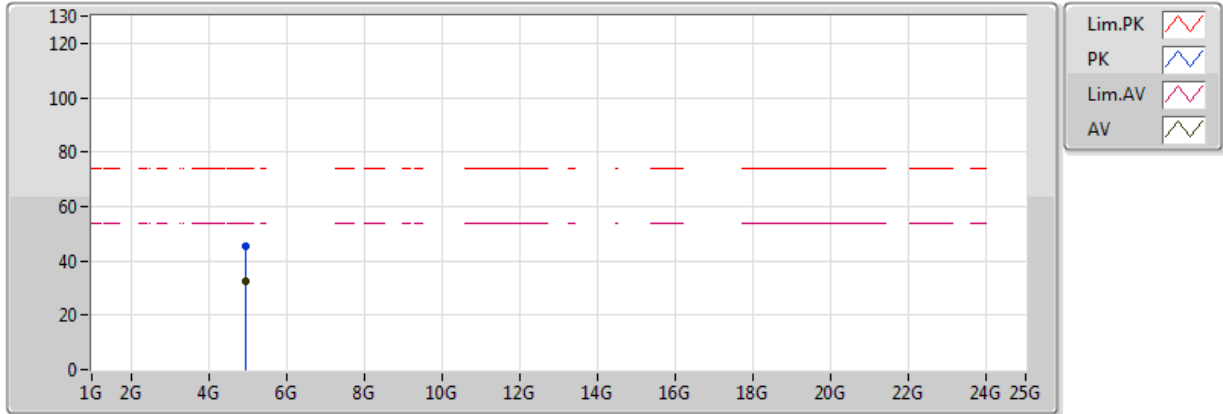

20171002  
 EUT\_Z\_1TX  
 Setting 61  
 01-M-1  
 FSP(100056)

Type	Freq(Hz)	Level(dBuV/m)	Limit(dBuV/m)	Margin(dB)	Factor(dB)	Dist(m)	Pol.(H/V)	Azimuth(°)	Height(m)	Comments
AV	4.96454G	32.24	54.00	-21.76	3.69	3	H	318	2.48	-
PK	4.96196G	45.57	74.00	-28.43	3.68	3	H	318	2.48	-

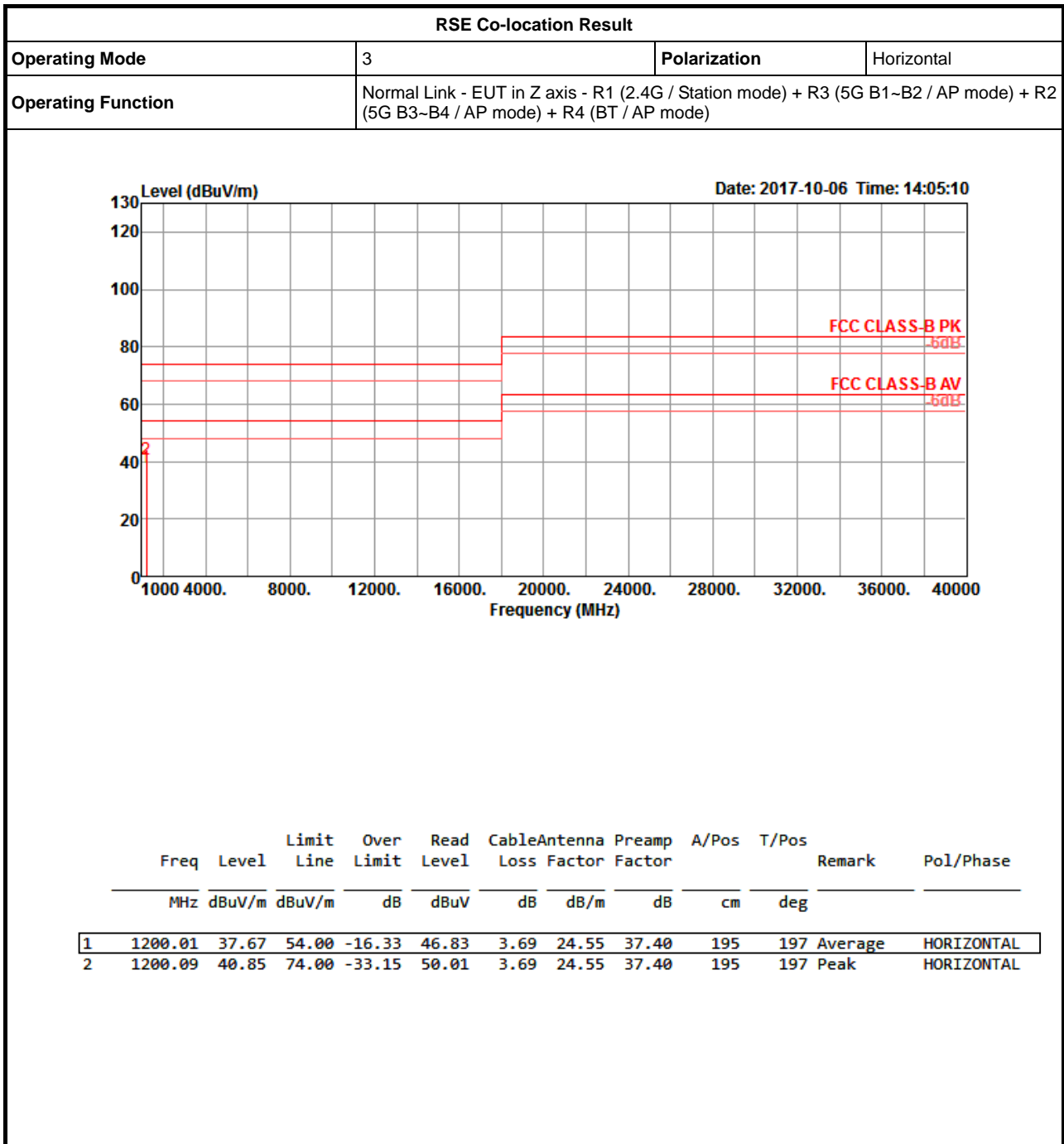



# RSE Co-location Result

