

ISED CABid: ES1909
 Lab. Company Number:4621A

Test report No:
 NIE: 72676RAN.004

Test report

ISED RSS - 102 Issue 5 (2015-03) AMD 1 (2021-02)
 IEC/IEEE 62209-1528:2020

(*) Identification of item tested	Continuous Positive Airway Pressure (CPAP) Device
(*) Trademark	ResMed
(*) Model and /or type reference tested	39485
(*) Derived model not tested	39523,39524,39525,39526,39527,39528
(*) Other identification of the product	FCC ID : 2ACHL-AIR11M1U IC ID : 9103A-AIR11M1U HW version : R390-7667 SW Version : SW04600
(*) Features	LTE Cat-M1, BLE
Manufacturer	RESMED Pty Ltd 1 Elizabeth Macarthur Drive, BELLA VISTA, NSW, 2153, AUSTRALIA
Test method requested, standard	1. ISED RSS-102 Issue 5 (2015-03) Amendment 1 (February 2, 2021). 2. IEC/IEEE 62209-1528:2020.
Summary	Considering the results of the performed test, the item under test is IN COMPLIANCE with IC RSS-102 Issue 5 exposure limits. The maximum 1g volume averaged SAR found during this test have been 0.503 W/kg, for LTE CAT M1 Band 66 mode.
Approved by (name / position & signature)	Miguel Lacave Antennas Lab Manager
Date of issue	2023-01-25
Report template No	FDT08_24 (*) "Data provided by the client"



Index

Competences and guarantees	3
General conditions	3
Uncertainty	3
Data provided by the client.....	3
Usage of samples	5
Test sample description	5
Identification of the client.....	5
Testing period and place.....	5
Document history	6
Environmental conditions	6
Remarks and comments	6
Testing verdicts.....	8
Summary	8
Appendix A: Test configuration	9
Appendix B: Test results	21
Appendix C: Measurement report	61
Appendix D: System Validation Report	74
Appendix E: Calibration data.....	83
Appendix F: Photographs.....	157

Competences and guarantees

DEKRA Testing and Certification S.A.U. is a testing laboratory accredited by the National Accreditation Body (ENAC -Entidad Nacional de Acreditación), to perform the tests indicated in the Certificate No. 51/LE 147.

DEKRA Testing and Certification is an ISED-recognized accredited testing laboratory CABid: ES1909, Company Number: 4621A, with appropriate scope of accreditation that include testing performed in this test report.

In order to assure the traceability to other national and international laboratories, DEKRA Testing and Certification S.A.U. has a calibration and maintenance program for its measurement equipment.

DEKRA Testing and Certification S.A.U. guarantees the reliability of the data presented in this report, which is the result of the measurements and the tests performed to the item under test on the date and under the conditions stated on the report and, it is based on the knowledge and technical facilities available at DEKRA Testing and Certification at the time of performance of the test.

DEKRA Testing and Certification S.A.U. is liable to the client for the maintenance of the confidentiality of all information related to the item under test and the results of the test.

The results presented in this Test Report apply only to the particular item under test established in this document.

IMPORTANT: No parts of this report may be reproduced or quoted out of context, in any form or by any means, except in full, without the previous written permission of DEKRA Testing and Certification S.A.U.

General conditions

1. This report is only referred to the item that has undergone the test.
2. This report does not constitute or imply on its own an approval of the product by the Certification Bodies or competent Authorities.
3. This document is only valid if complete; no partial reproduction can be made without previous written permission of DEKRA Testing and Certification S.A.U.
4. This test report cannot be used partially or in full for publicity and/or promotional purposes without previous written permission of DEKRA Testing and Certification S.A.U. and the Accreditation Bodies.

Uncertainty

Uncertainty (factor $k=2$) was calculated according to the following documents:

1. DEKRA Testing and Certification S.A.U. internal document PODT000.
2. IEC/IEEE 62209-1528. Measurement procedure for the assessment of specific absorption rate of human exposure to radio frequency fields from hand-held and body-mounted wireless communication devices – Part 1528: Human models, instrumentation, and procedures (Frequency range of 4 MHz to 10 GHz).

Data provided by the client

The following data has been provided by the client:

1. Information relating to the description of the sample ("Identification of the item tested", "Trademark", "Model and/or type reference tested", "Derived model not tested", "Other identification of the product", "Features" and "Test sample description").
2. Maximum output power and testing distance information.
3. Derived model not tested. These models have been declared by the supplier of the sample as being the same as the model under test.



Date: 30-Nov-2022

DECLARATION OF EQUIVALENCE

This document declares that the following designated products are equivalent to the unit under test 39485.

Model Name / Product Code	Marketing Name
39523	AirSense 11 AutoSet USA
39524	AirSense 11 CPAP USA
39525	AirSense 11 Elite USA
39526	AirSense 11 AutoSet CAN
39527	AirSense 11 CPAP CAN
39528	AirSense 11 Elite CAN

All the above stated products and the unit under test - 39485 have the same cellular hardware and firmware.

Applicant:

Company Name: ResMed Pty Ltd
Address: 1 Elizabeth Macarthur Drive,
Bella Vista NSW 2153
Australia

By,



Christopher Jenkins
Title: Manager – Systems Engineering
Company: ResMed Pty Ltd
Telephone: +61 2 8884 1517
e-mail: Christopher.jenkins@resmed.com.au

DEKRA Testing and Certification S.A.U. declines any responsibility with respect to the information provided by the client and that may affect the validity of results.

Usage of samples

Samples undergoing test have been selected by: the client

Sample M/01 is composed of the following elements:

Control Nº	Description	Model	Serial Nº	Date of reception
72676/002	Respirator (Conducted Unit)	Air11	22222172433	10/10/2022
72943/026	Power Cord			04/08/2022
72943/019	AC/DC	390000	0001R902	04/08/2022

Sample M/02 is composed of the following elements:

Control Nº	Description	Model	Serial Nº	Date of reception
72943/026	Power Cord			04/08/2022
72943/019	AC/DC	390000	0001R902	04/08/2022
72676/005	Respirator (Radiated Unit)	Air11	22222172415	19/10/2022

1. Sample M/01 has undergone the test(s) specified in subclause "Test method requested": Conducted average output power.
2. Sample M/02 has undergone the test(s) specified in subclause "Test method requested": SAR evaluation for LTE modes.

Test sample description

Description of product	CPAP device with integrated cellular and Bluetooth connectivity		
Software version.....	SW04600		
Hardware version	R390-7667		
Mounting position	<input checked="" type="checkbox"/>	Table top equipment	
	<input type="checkbox"/>	Wall/Ceiling mounted equipment	
	<input type="checkbox"/>	Equipment used next to the ear	
	<input type="checkbox"/>	Hand-held equipment	
	<input type="checkbox"/>	Other: Body-worn device	
Accessories (not part of the test item).....	Description	Type	Manufacturer
	Charging adapter	---	

Identification of the client

ResMed Pty Ltd.

1 Elizabeth Macarthur Drive, Bella Vista, NSW 2153 Australia

Testing period and place

Test Location	DEKRA Testing and Certification S.A.U.
Date (start)	2022-10-13
Date (finish)	2022-11-29

Document history

Report number	Date	Description
72676RAN.004	2023-01-25	First release

Environmental conditions

Date	Max. Temp. °C	Min. Temp. °C	Max. Hum. %	Min. Hum. %	Limit
From 2022-10-13 to 2022-11-10	24.35	20.66	69.26	38.59	18-25 °C, 30-70%

Remarks and comments

1. Zoom scan is not required according to FCC OET KDB 447498 D01 General RF Exposure Guidance 06, paragraph "4.4.2. Area scan based 1-g estimation".
2. Bottom edge of the device has not been tested due to testing reduction. The device is a top-table device, therefore this side will be always facing a table and the transmitting antenna is located on the opposite device edge (Top edge).
3. Zoom scan and/or power drifts measurements have not been able to be performed by the measurement system due to very low SAR values close to or under the noise level.
4. Testing of Bluetooth mode is not required according to IC RSS-102 Issue 5 (2015-03) – Radio Frequency Exposure Compliance of Radiocommunication Apparatus (All Frequency Bands), paragraph 2.5.1 Exemption Limits for Routine Evaluation – SAR Evaluation
5. Only the plots of the highest reported SAR for each test position and mode/band are included in appendix C.
6. The tests have been performed by the technical personnel: Francisco J. Sánchez and Ismael Gamarro.
7. References:

The tests documented in this report were performed in accordance with IC RSS-102 Issue 5 (2015-03) AMD 1 (2021-02) – Radio Frequency Exposure Compliance of Radiocommunication Apparatus (All Frequency Bands), IEC/IEEE 62209-1528:2020 standard and the following FCC Published RF exposure KDB procedures:

- FCC OET KDB 447498 D01 General RF Exposure Guidance v06 (October 2015)
- FCC OET KDB 941225 D05 SAR for LTE Devices v02r05 (October 2015).

8. The instrumentation utilized to perform the tests covered in this test report is listed in the following table:

Equipment	NC
Dosimetric E-field probe SPEAG EX3DV4	6125
Dosimetric E-field probe SPEAG EX3DV4	9513
Data acquisition device SPEAG DAE4	8876
Data acquisition device SPEAG DAE4	3430
SPEAG Mounting Device for Laptop and Body-Worn Transmitters	3526
Oval flat phantom SPEAG ELI 4	3525
Electro-optical converter SPEAG EOC3	3438
Robot Stäubli RX60BL	3420
Robot controller Stäubli CS7MB	3436
Measurement server SPEAG DASY5 SE UMS 011 BS	3847
SAR measurement software SPEAG DASY52 V52.10.4.1527	3423
SAR postprocessing software SPEAG SEMCAD X	3423
Electro-optical converter SPEAG EOCip -60 SE UMS 018 BB	8902
Robot Stäubli TX60L	8867
Robot controller STÄUBLI CS8C	8894
Measurement server SPEAG DASY6 SE UMS 028 CA	8895
SAR measurement software SPEAG cDASY6 16.2.2.1588	8898
Head Tissue Equivalent Liquid for 750 MHz band	3921
Head Tissue Equivalent Liquid for 600 - 10000 MHz band	9449
Body Tissue Equivalent Liquid for 750 MHz band	3921
Body Tissue Equivalent Liquid for 850 MHz band	3632
Body Tissue Equivalent Liquid for 1700 MHz band	8845
Body Tissue Equivalent Liquid for 1900 MHz band	8845
750 MHz dipole validation kit SPEAG D750V3	3919
900 MHz dipole validation kit SPEAG D900V2	3426
1800 MHz dipole validation kit SPEAG D1800V2	3427
Vector network analyzer Agilent FieldFox N9923A	4482
Dielectric probe kit SPEAG DAK-3.5	4171
SPEAG DAK software V1.10.325.10	4859
RF Generator R&S SMU200	3346
Power amplifier MITEQ AMF-4D-00400600-50-30P	3485
DC Power supply Agilent U8002A	4835
Dual directional coupler HP 778D	1084
Dual directional coupler NARDA 4227-16	3630
Power sensor Agilent E9300A	4391
Power sensor Agilent E9300A	4392
Power meter Agilent E4419B	4393
Power sensor DC 50 MHz to 18 GHz R&S model NRP-Z81	4164
Digital thermometer LKM Electronics model DTM300-Spezial	4170
Temperature and humidity probe HUMIDIPROBE Pico Technology	3453
Wideband Radio Communication Tester R&S CMW 500	8849

Testing verdicts

Not applicable :	N/A
Pass :	P
Fail :	F
Not measured :	N/M

Summary

ISED RSS - 102 Issue 5 (2015-03) AMD 1 (2021-02)	VERDICT			
	N/A	P	F	NM
LTE CAT M1 Band 2		P		
LTE CAT M1 Band 4		P		
LTE CAT M1 Band 5		P		
LTE CAT M1 Band 12		P		
LTE CAT M1 Band 13		P		
LTE CAT M1 Band 25		P		
LTE CAT M1 Band 26		P		
LTE CAT M1 Band 66		P		
LTE CAT M1 Band 71		P		
Bluetooth LE		P ¹		
1: Technology not subject to testing. Verdict has been determined through RF Exposure assessment (see Appendix B, 2.2 of this document for more details).				

Appendix A: Test configuration

Index

1.	GENERAL INTRODUCTION	11
1.1.	Application Standard.....	11
1.2.	General requirements	11
1.3.	Measurement system requirements	11
1.4.	Phantom requirements.....	11
1.5.	Measurement Liquids requirements	12
2.	MEASUREMENT SYSTEM	13
2.1.	Measurement System	13
2.2.	Device Holder	17
2.3.	Test Positions of device relative to head and body	17
2.4.	Test to be performed.....	17
2.5.	Description of interpolation/extrapolation scheme	17
2.6.	Determination of the largest peak spatial-average SAR	17
2.7.	System Check.....	18
3.	UNCERTAINTY	19
4.	SAR LIMIT	20
5.	DEVICE UNDER TEST	20
5.1.	Dimensions.....	20
5.2.	Wireless Technology.....	20
5.3.	Simultaneous Transmission	20
5.4.	Antenna Location.....	20

1. GENERAL INTRODUCTION

1.1. Application Standard

Industry of Canada (ISED) sets the limits for General Population/Uncontrolled environment when the exposure occurs at a distance of 0.2 m or less into the RSS-102 Issue 5, paragraph 4 “Exposure Limits”, Table 3.

1.2. General requirements

The SAR measurement has been performed continuing the following considerations and environment conditions:

The ambient temperature shall be in the range of 18°C to 25°C and the variation shall not exceed +/-2°C during the test.

The ambient humidity shall be in the range of and 30% - 70%.

The device battery shall be fully charged before each measurement.

1.3. Measurement system requirements

The measurement system used for SAR tests fulfills the procedural and technical requirements described at Point 6 (“Measurement system specifications”) of IEC/IEEE 62209-1528.

1.4. Phantom requirements

The phantom model for body measurements is an elliptical open-top container with a flat bottom, with shape, dimensions and materials defined at Point “6.2.4 Flat Phantom” of IEC/IEEE 62209-1528:

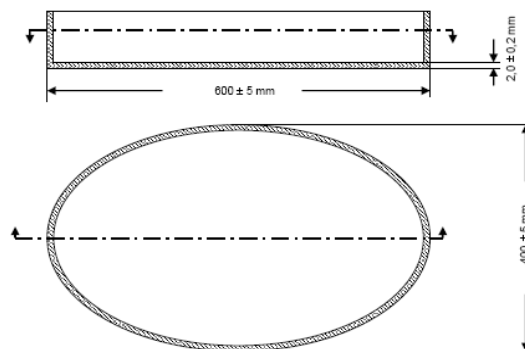

Figure 1: Proportions and shape of Phantom shell

a) Except as specified in item b), the shape of the phantom shall be an ellipse with length 600 mm ± 5 mm and width 400 mm ± 5 mm (see Figure 3).

b) For frequencies above 150 MHz and for separation distances less than or equal to 25 mm from the outer surface of the bottom of the phantom shell, phantoms with other shapes and smaller dimensions are allowed as follows:

- between 150 MHz and 800 MHz, the phantom flat bottom wall may have any shape that encompasses an ellipse with length $0,6 \lambda_0$ and width $0,4 \lambda_0$, where λ_0 is the wavelength in air.
- between 800 MHz and 6 GHz, the phantom may have any shape flat bottom wall that encompasses an ellipse with length 225 mm and width 150 mm.

1.5. Measurement Liquids requirements

The liquids used to simulate the human tissues, must fulfill the requirements of the dielectric properties required. These dielectric properties of the liquids are indicated in the IEC/IEEE 62209-1528, point “6.2.2. Table 2 – Dielectric properties of the tissue-equivalent medium”. For the applicable transmission bands, the requirements are included in the following table:

Frequency (MHz)	ϵ_r	σ (S/m)
750	41.94	0.89
835	41.5	0.90
900	41.5	0.97
1750	40.07	1.37
1800	40.0	1.40
2000	40.0	1.40
2450	39.2	1.80
2600	39.0	1.96
5200	36.0	4.66
5500	35.65	4.97
5800	35.3	5.27

Table 1: Liquid material requirements

As indicated in Point 6.1.1 of IEC/IEEE 62209-1528, tissue-equivalent media shall yield measured relative permittivity and conductivity values within $\pm 5\%$ of the target values at frequencies at which the SAR is measured. When the method of 7.8 is used to correct the measured SAR for the deviations in permittivity and conductivity, the tolerance may be relaxed to a maximum of $\pm 10\%$ from the targets.

To minimize the effect of reflections on peak spatial-average SAR values, from the upper surface of the tissue equivalent liquid, the depth of the liquid should be at least 15 cm.

Dielectric properties values of the Tissue Simulant Liquids used for SAR measurements are included in Appendix B, Section 3, of this document.

2. MEASUREMENT SYSTEM

2.1. Measurement System

The DASY5 system for performing compliance tests consists of the following items:

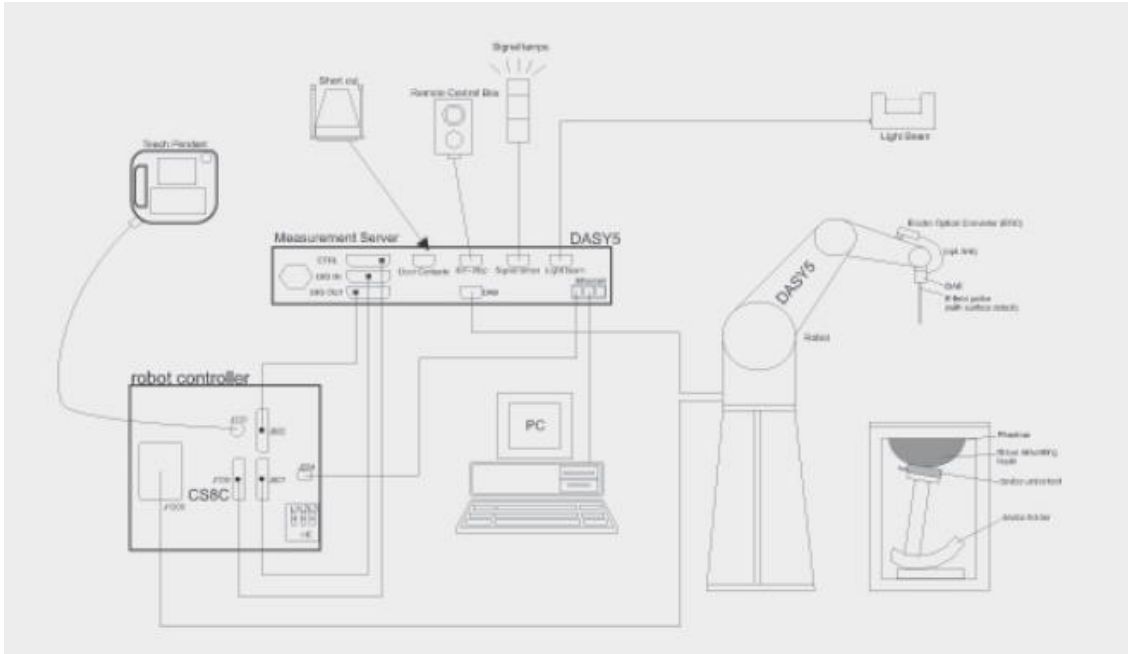

Figure 2: DASY5 SAR Measurement system

The DASY6 system for performing compliance tests consists of the following items:

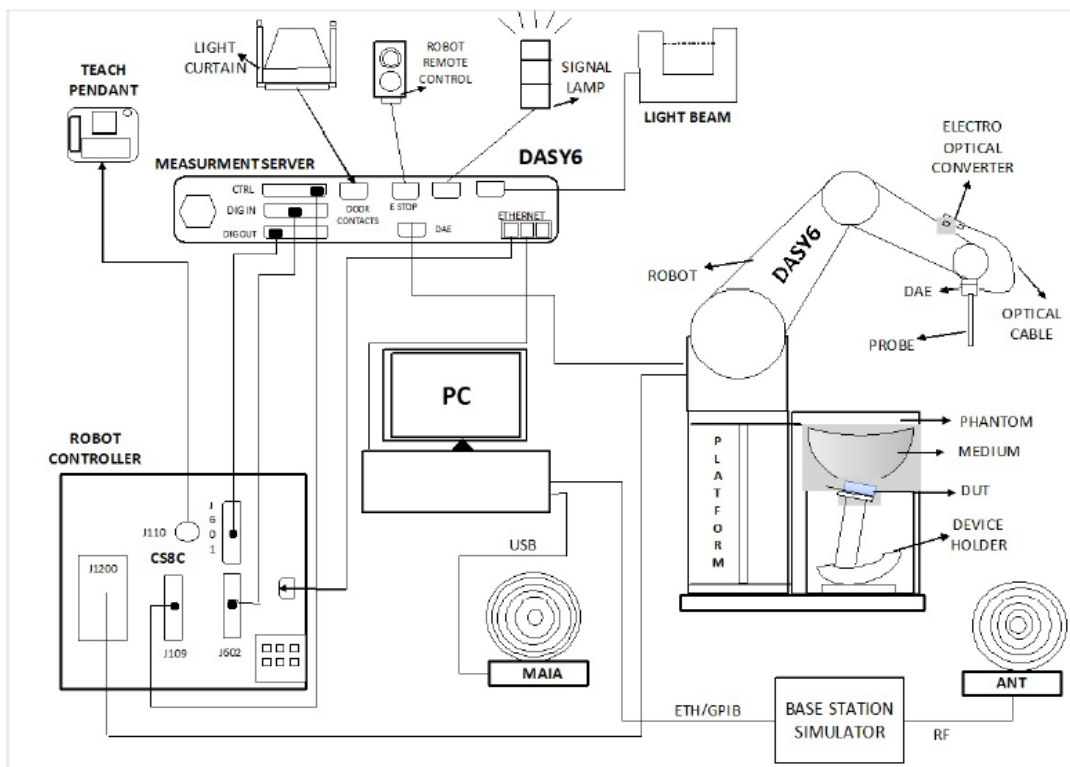





Figure 3: DASY6 SAR Measurement system

- A standard high precision 6-axis robot (Stäubli TX=RX family) with controller, teach pendant and software. An arm extension for accommodating the data acquisition electronics (DAE).
- An isotropic field probe optimized and calibrated for the targeted measurement.
- A data acquisition electronics (DAE) which performs the signal amplification, signal multiplexing, AD-conversion, offset measurements, mechanical surface detection, collision detection, etc. The unit is battery powered with standard or rechargeable batteries. The signal is optically transmitted to the EOC.
- The Electro-optical converter (EOC) performs the conversion from optical to electrical signals for the digital communication to the DAE. To use optical surface detection, a special version of the EOC is required. The EOC signal is transmitted to the measurement server.
- The function of the measurement server is to perform the time critical tasks such as signal filtering, control of the robot operation and fast movement interrupts.
- The Light Beam used is for probe alignment. This improves the (absolute) accuracy of the probe positioning.
- A computer running the DASY software.
- Remote control and teach pendant as well as additional circuitry for robot safety such as warning lamps, etc.
- The phantom, the device holder and other accessories according to the targeted measurement.

	Model	EX3DV4
	Construction	Symmetrical design with triangular core. Built-in shielding against static charges. PEEK enclosure material (resistant to organic solvents, e.g., DGBE).
	Frequency	10 MHz to > 6 GHz; Linearity: ± 0.2 dB (30 MHz to 6 GHz)
	Directivity	± 0.3 dB in TSL (rotation around probe axis) ± 0.5 dB in TSL (rotation normal to probe axis)
	Dynamic Range	10 μ W/g to > 100 mW/g Linearity: ± 0.2 dB (noise: typically < 1 μ W/g)
	Dimensions	Overall length: 337 mm (Tip: 20 mm) Tip diameter: 2.5 mm (Body: 12 mm) Typical distance from probe tip to dipole centers: 1.0 mm

	Model	DAE4
	Construction	Signal amplifier, multiplexer, A/D converter, and control logic. Serial optical link communication with DASY4/5 embedded system (fully remote controlled). Two-step probe touch detector for mechanical surface detection and emergency robot stop.
	Measurement Range	-100 to +300 mV (16 bit resolution and two range settings: 4mV, 400mV)
	Input Offset Voltage	< 5 μ V (with auto zero)
	Input Resistance	200 MOhm
	Input Bias Current	< 50 fA

	Model	ELI
	Construction	Phantom for compliance testing of handheld and body-mounted wireless devices in the frequency range of 30 MHz to 6 GHz. ELI is fully compatible with the IEC 62209-2 standard and all known tissue simulating liquids. ELI has been optimized regarding its performance and can be integrated into our standard phantom tables. A cover prevents evaporation of the liquid. Reference markings on the phantom allow installation of the complete setup, including all predefined phantom positions and measurement grids, by teaching three points. The phantom is compatible with all SPEAG dosimetric probes and dipoles.
	Material	Vinylester, glass fiber reinforced (VE-GF)
	Liquid Compatibility	Compatible with all SPEAG tissue simulating liquids (incl. DGBE type)
	Shell Thickness	2 \pm 0.2 mm (bottom plate)
	Dimensions	Major axis: 600 mm, Minor axis: 400 mm
	Filling Volume	Approx. 30 liters
	Wooden Support	SPEAG standard phantom table

	Model	Mounting Device for Laptop and Body-Worn Transmitters
	Construction	In combination with the Twin SAM V5.0/V5.0c or ELI Phantoms, the Mounting Device (Body-worn) enables testing of transmitters devices according to IEC 62209-2 specifications. The device holder can be locked for positioning at flat phantom section.
	Material	Polyoxymethylene (POM), PET-G, Foam

	Model	System Validations Kits 450 MHz – 6 GHz			
	Construction	Symmetrical dipole with 1/4 balun. Enables measurement of feedpoint impedance with NWA. Matched for use near flat phantoms filled with tissue simulating solutions.			
	Frequency	450 MHz to 5800 MHz			
	Return Loss	20 dB at specified validation position			
	Dimensions (length and overall height in mm)	Product	Dipole length	Overall height	
		D450V3	290.0	330.0	
		D750V3	179.0	330.0	
D900V2		148.5	340.0		
D1800V2		72.5	300.0		
D2000V2		65.0	300.0		
D2300V2		56.3	290.0		
D2450V2		52.0	290.0		
D2600V2		49.2	290.0		
D3300V2		38.0	285.0		
D3500V2		37.0	285.0		
D3700V2		34.7	285.0		
D3900V2		32.0	280.0		
D4200V2		30.1	280.0		
D4600V2	27.0	280.0			
D4900V2	25.0	280.0			
D5GHzV2	20.6	300.0			

2.2. Device Holder

The SAR in the phantom is approximately inversely proportional to the square of the distance between the source and the liquid surface. For a source in 5mm distance, a positioning uncertainty of ± 0.5 mm would produce a SAR uncertainty of $\pm 20\%$. An accurate device positioning is therefore crucial for accurate and repeatable measurements. The positions, in which the devices must be measured, are defined by the standards.

The DASY Laptop Holder extension is lightweight and made of POM, PET-G acrylic glass and foam. It fits easily on the upper part of the Mounting Device in place of the phone positioner. The extension is fully compatible with the Twin-SAM and ELI phantoms.

2.3. Test Positions of device relative to head and body

The device under test consists of a continuous Positive Airway Pressure (CPAP) Device which could be used near the head and body of the user placed on a bedside table.

Although it will be used normally at higher distance from users, according to the manufacturer request, SAR testing has been performed at a conservative test separation distance of 15 mm.

All device edges have been tested facing the flat phantom at 15 mm test distance, except the back face of the device, measured at 45 mm due to mains cord and the bottom edge of the device due to testing reduction based on device use and tests results found for the rest of device's sides.

2.4. Test to be performed

Test shall be performed for each test position previously described, using the channel producing the highest rated output power.

Additionally the other applicable test frequency channels must be measured for the test configuration providing the highest SAR for each applicable transmitting band.

2.5. Description of interpolation/extrapolation scheme

The local SAR inside the Phantom is measured using small dipole sensing elements inside a probe element. The probe tip must not be in contact with the Phantoms surface in order to minimise measurement errors, but the highest local SAR is obtained from measurements at a certain distances from the shell through extrapolation. The accurate assessment of the maximum SAR averaged over 10 gr. requires a very fine resolution in the three dimensional scanned data array. Since the measurements have to be performed over a limited time, the measured data have to be interpolated to provide an array of sufficient resolution.

The interpolation of 2D area scan is used after the initial area scan, at a fixed distance from the Phantom shell wall. The initial scan data is collected with approx. 15 mm spatial resolution and this interpolation is used to find the location of the local maximum for positioning the subsequent 3D scanning within a 1mm resolution.

For the 3D scan, data is collected on a spatially regular 3D grid having 5 mm steps in both directions. After the data collection by the SAR probe, the data are extrapolated in the depth direction to assign values to points in the 3D array closer to the shell wall. A notional extrapolation value is also assigned to the first point outside the shell wall so that subsequent interpolation schemes will be applicable right up to the shell wall boundary.

2.6. Determination of the largest peak spatial-average SAR

To determine the maximum value of the peak spatial-average SAR of a DUT, all device positions, configurations and operational modes should be tested for each frequency band.

The averaging volume shall be chosen as 1gr. of contiguous tissue. The cubic volumes, over which the SAR measurements are averaged after extrapolation and interpolation, are chosen in order to include the highest values of local SAR.

The maximum SAR level for the DUT will be the maximum level obtained of the performed measurements indicated in the previous points.

2.7. System Check

Prior to the SAR measurements, system verification is done to verify the system accuracy. As “IEC/IEEE 62209-1528:2020 Annex A. A.2” specifies, a complete SAR evaluation is done using a half-wavelength dipole as source with the frequency of the mid-band channel of the operating band, or within 10% of this channel, whichever is greater.

The measured 1 gr. and 10 gr. SAR should be within 10% of the expected target values specified in the calibration certificate of the dipole, for the specific tissue and frequency used.

3. UNCERTAINTY

Uncertainty for 300 MHz – 3 GHz

Symbol	Input quantity X_i (source of uncertainty)	Ref.	Prob. Dist. PDFi	Unc. a(xi)	Div. qi	ci 1g	ci 10g	$u(y) = ci \cdot u(xi)$ 1g	$u(y) = ci \cdot u(xi)$ 10g
Measurement system errors									
CF	Probe calibration	8.4.1.1	N (K=2)	13.30%	2	1	1	6.65%	6.65%
CFdrift	Probe calibration drift	8.4.1.2	R	1.70%	$\sqrt{3}$	1	1	0.98%	0.98%
LIN	Probe linearity and detection limit	8.4.1.3	R	4.70%	$\sqrt{3}$	1	1	2.71%	2.71%
BBS	Broadband signal	8.4.1.4	R	3.00%	$\sqrt{3}$	1	1	1.73%	1.73%
ISO	Probe isotropy	8.4.1.5	R	7.56%	$\sqrt{3}$	1	1	4.36%	4.36%
DAE	Other probe and data acquisition errors	8.4.1.6	N	0.30%	1	1	1	0.30%	0.30%
AMB	RF ambient and noise	8.4.1.7	N	1.80%	1	1	1	1.80%	1.80%
Dxyz	Probe positioning errors	8.4.1.8	N	2.90%	$\sqrt{3}$	0.14	0.14	0.23%	0.23%
DAT	Data processing errors	8.4.1.9	N	2.00%	$\sqrt{3}$	1	1	1.15%	1.15%
Phantom and device (DUT or validation antenna) errors									
LIQ(σ)	Measurement of phantom conductivity(σ)	8.4.2.1	N	3.57%	1	0.78	0.71	2.79%	2.54%
LIQ(T_c)	Temperature effects (medium)	8.4.2.2	R	2.30%	$\sqrt{3}$	0.78	0.71	1.04%	0.94%
EPS	Shell permittivity	8.4.2.3	R	14.00%	$\sqrt{3}$	0	0	0.00%	0.00%
DIS	Distance between the radiating element of the DUT and the phantom medium	8.4.2.4	N	2.00%	1	2	2	4.00%	4.00%
Dxyz	Repeatability of positioning the DUT or source against the phantom	8.4.2.5	N	1.00%	1	1	1	1.00%	1.00%
H	Device holder effects	8.4.2.6	N	3.60%	1	1	1	3.60%	3.60%
MOD	Effect of operating mode on probe sensitivity	8.4.2.7	R	2.40%	$\sqrt{3}$	1	1	1.39%	1.39%
TAS	Time-average SAR	8.4.2.8	R	1.73%	$\sqrt{3}$	1	1	1.00%	1.00%
RFdrift	Variation in SAR due to drift in output of DUT	8.4.2.9	N	2.50%	1	1	1	2.50%	2.50%
VAL	Validation antenna uncertainty (validation measurement only)	8.4.2.10	N	3.20%	1	1	1	3.20%	3.20%
Pin	Uncertainty in accepted power (validation measurement only)	8.4.2.11	N	2.00%	1	1	1	2.00%	2.00%
Corrections to the SAR result (if applied)									
C($\epsilon\phi, \sigma$)	Phantom deviation from target ($\epsilon\phi, \sigma$)	8.4.3.1	N	1.90%	1	1	0.84	1.90%	1.60%
C(R)	SAR scaling	8.4.3.2	R	0.00%	$\sqrt{3}$	1	1	0.00%	0.00%
U (DSAR)	Combined uncertainty (Validation Antenna)							10.85%	10.73%
U	Expanded uncertainty and effective degrees of freedom (Validation Antenna)					U (K=2)=		21.70%	21.46%
U (DSAR)	Combined uncertainty (DUT)							11.44%	11.33%
U	Expanded uncertainty and effective degrees of freedom (DUT)					U (K=2)=		22.88%	22.65%

Table 2: Uncertainty Assessment for 300 MHz - 3 GHz according to IEC/IEEE 62209-1528:2020.

4. SAR LIMIT

Having a worst-case measurement, the SAR limit is valid for general population/uncontrolled exposure.

The SAR values have to be averaged over a mass of 1 gr. (SAR 1 gr.) with the shape of a cube and averaged over a mass of 10 gr (Extremity SAR 10 gr). These levels could not exceed the values indicated in the application Standard:

Standard	Exposure	SAR	SAR Limit (W/kg)
RSS-102 Issue 5 (2015-03), Paragraph 4	General population/Uncontrolled	SAR 1-g.	1.6
RSS-102 Issue 5 (2015-03), Paragraph 4	General population/Uncontrolled Extremity	SAR 10-g.	4.0

Table 3: SAR limit

5. DEVICE UNDER TEST

5.1. Dimensions

Dimensions	Millimetres
Length x Width x Height	95.0 x 235.0 x 125.0

Table 4: DUT dimensions

5.2. Wireless Technology

Wireless Technology	Frequency Bands	Modes	Duty Cycle used for SAR testing
LTE CAT-M1	2/4/5/12/13/25/26/66/85	QPSK and 16-QAM	FDD: 29.72%, TDD: 29.72%
Bluetooth	2.4 GHz	Bluetooth LE	SAR Low-Power Exclusion compliant

Table 5: Supported modes

5.3. Simultaneous Transmission

Simultaneous transmission evaluation was performed according to FCC OET KDB 447498 D01 General RF Exposure Guidance v06 (October 2015). The detailed simultaneous transmission combination is:

RF Exposure Condition	Simultaneous transmission configurations
Head & Body	LTE CAT-M1 + Bluetooth LE

Table 6: Simultaneous transmission

5.4. Antenna Location

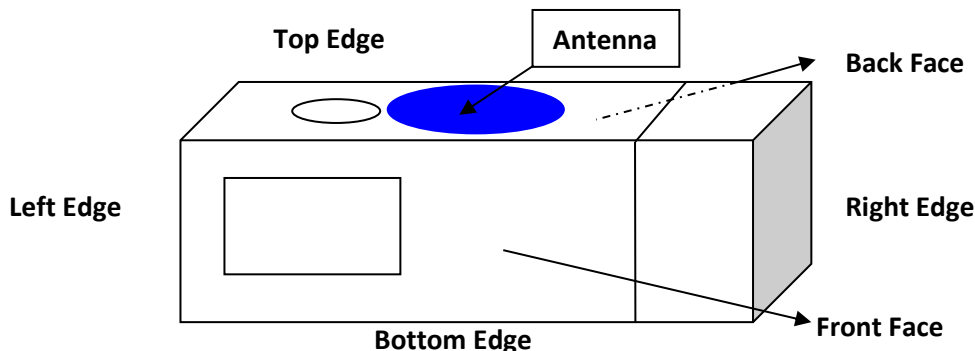

Figure 4: Antenna diagram location sketch (front face view)

Appendix B: Test results

Index

1.	TEST CONDITIONS	23
1.1.	Power supply (V):	23
1.2.	Temperature (°C):	23
1.3.	DUT information and test-site configurations	23
1.4.	Test signal, Output Power and Frequencies	23
2.	CONDUCTED AVERAGE POWER MEASUREMENTS	24
2.1.	Cellular Antenna	24
2.1.1.	LTE Bands	24
2.1.1.1.	LTE Bands	24
2.2.	BLUETOOTH ANTENNA	44
3.	TISSUE PARAMETERS MEASUREMENTS	45
4.	SYSTEM CHECK MEASUREMENTS	47
4.1.	Validation results for Head TSL	47
4.2.	Validation results for Body TSL	47
5.	MEASUREMENT RESULTS FOR SAR (SPECIFIC ABSORPTION RATE)	48
5.1.	Summary maximum results for head measurements.	48
5.2.	Summary maximum results for body measurements	48
5.3.	Maximum multi-transmission SAR	48
5.4.	Results for LTE CAT M1 Band 12 (1 Rb, 10 MHz, QPSK).	49
5.5.	Results for LTE CAT M1 Band 12 (50% Rb, 10 MHz, QPSK).	50
5.6.	Results for LTE CAT M1 Band 13 (1 Rb, 10 MHz, QPSK).	51
5.7.	Results for LTE CAT M1 Band 13 (50% Rb, 10 MHz, QPSK).	52
5.8.	Results for LTE CAT M1 Band 25 (1 Rb, 20 MHz, QPSK).	53
5.9.	Results for LTE CAT M1 Band 25 (50% Rb, 20 MHz, QPSK).	54
5.10.	Results for LTE CAT M1 Band 26 (1 Rb, 15 MHz, QPSK).	55
5.11.	Results for LTE CAT M1 Band 26 (50% Rb, 15 MHz, QPSK).	56
5.12.	Results for LTE CAT M1 Band 66 (1 Rb, 20 MHz, QPSK).	57
5.13.	Results for LTE CAT M1 Band 66 (50% Rb, 20 MHz, QPSK).	58
5.14.	Results for LTE CAT M1 Band 71 (1 Rb, 20 MHz, QPSK).	59
5.15.	Results for LTE CAT M1 Band 71 (50% Rb, 20 MHz, QPSK).	60

1. TEST CONDITIONS

1.1. Power supply (V):

Type of power supply = 65W AC Adapter.

1.2. Temperature (°C):

Tn = +20.00 to +25.00

The subscript n indicates normal test conditions.

1.3. DUT information and test-site configurations

For all supported modes, the DUT was placed with each face and edge position against the flat phantom surface, except the bottom edge of the device due to testing reduction.

The separation distance between DUT and flat phantom surface was 45 mm for the back face of the device due to mains cord, and 15 mm for the remaining faces/edges.

1.4. Test signal, Output Power and Frequencies

The sample was put into operation by using an R&S CMW 500 as base station simulator for the LTE Cat-M1 transmitting technologies.

The actual SAR sample does not have accessible antenna connectors for conducted measurements, so the conducted average output power was measured using others identical samples (M/01) provided by the manufacturer with auxiliary external connectors that makes the measurements representative and applicable for all the tested samples. See 'usage of samples' paragraph of this report.

The maximum conducted time-averaged power of the device for each mode was measured with a power sensor R&S NRP-Z81.

The target power alignments, including tune-up tolerance, for RF components declared by the manufacturer for each supported technology are:

Output Power (dBm)	CAT M1 Transmission Mode								
	LTE B2	LTE B4	LTE B5	LTE B12	LTE B13	LTE B25	LTE B26	LTE B66	LTE B71
Maximum Burst	25.0	25.0	25.0	25.0	25.0	25.0	25.0	25.0	25.0
Maximum Averaged	19.73	19.73	19.73	19.73	19.73	19.73	19.73	19.73	19.73

Output Power (dBm)	Transmission Mode
	Bluetooth LE
Maximum	0.0

2. CONDUCTED AVERAGE POWER MEASUREMENTS

2.1. Cellular Antenna

2.1.1. LTE Bands

2.1.1.1. LTE Bands

LTE MPR is permanently implemented for the device. A-MPR was disabled for all SAR tests. The following power reductions are used for higher RB allocations and 16-QAM modulation:

Modulation	Channel bandwidth / Transmission bandwidth configuration [RB]						MPR (dB)
	1.4 MHz	3.0 MHz	5 MHz	10 MHz	15 MHz	20 MHz	
QPSK	> 5	> 4	> 8	> 12	> 16	> 18	≤ 1
16 QAM	≤ 5	≤ 4	≤ 8	≤ 12	≤ 16	≤ 18	≤ 1
16 QAM	> 5	> 4	> 8	> 12	> 16	> 18	≤ 2

- LTE CAT M1 B2

Band	BW	Modulation	Mode	MPR	Average Output Power (dBm)		
					Low CH	Mid CH	High CH
					1860.0 MHz	1880.0 MHz	1900.0 MHz
LTE B2	20 MHz	QPSK	1RB Low	0	16.65	16.74	16.81
			1RB Mid	0	16.80	16.84	16.90
			1RB High	0	16.96	17.07	17.12
			50% Low	1	16.59	16.71	16.77
			50% Mid	1	16.69	16.76	16.81
			50% High	1	16.78	16.82	16.93
			100%	1	16.66	16.78	16.84
		16-QAM	1RB Low	1	16.59	16.74	16.83
			1RB Mid	1	16.67	16.84	16.92
			1RB High	1	16.90	17.06	17.17
			50% Low	2	16.82	16.95	17.08
			50% Mid	2	16.92	17.00	17.10
			50% High	2	16.97	17.06	17.18
			100%	2	16.88	16.98	17.07
Band	BW	Modulation	Mode	MPR	Low CH	Mid CH	High CH
LTE B2	15 MHz	QPSK	1RB Low	0	16.67	16.84	16.69
			1RB Mid	0	16.70	16.93	16.78
			1RB High	0	16.92	17.17	17.00
			50% Low	1	16.58	16.79	16.62
			50% Mid	1	16.64	16.85	16.68
			50% High	1	16.70	16.92	16.74
			100%	1	16.64	16.87	16.70
		16-QAM	1RB Low	1	16.61	16.83	16.69
			1RB Mid	1	16.70	16.93	16.76
			1RB High	1	16.94	17.15	16.97
			50% Low	2	16.85	17.06	16.95
			50% Mid	2	16.90	17.11	16.98
			50% High	2	16.97	17.18	17.02
			100%	2	16.88	17.07	16.90

Band	BW	Modulation	Mode	MPR	Average Output Power (dBm)		
					Low CH	Mid CH	High CH
					1855.0 MHz	1880.0MHz	1905.0 MHz
LTE B2	10 MHz	QPSK	1RB Low	0	16.90	16.81	16.79
			1RB Mid	0	17.03	16.98	17.03
			1RB High	0	17.20	17.14	17.15
			50% Low	1	16.83	16.78	17.02
			50% Mid	1	16.91	16.85	17.02
			50% High	1	17.02	16.98	17.03
			100%	1	16.89	16.84	16.92
		16-QAM	1RB Low	1	16.70	16.79	16.84
			1RB Mid	1	16.85	16.96	16.97
			1RB High	1	17.00	17.13	17.18
			50% Low	2	17.05	16.77	16.83
			50% Mid	2	17.18	16.89	16.94
			50% High	2	17.24	16.96	17.05
			100%	2	16.09	17.14	16.88
Band	BW	Modulation	Mode	MPR	Low CH	Mid CH	High CH
					1852.5 MHz	1880.0 MHz	1907.5 MHz
LTE B2	5 MHz	QPSK	1RB Low	0	16.62	16.96	16.78
			1RB Mid	0	16.80	17.11	16.98
			1RB High	0	16.98	17.25	17.07
			50% Low	1	16.60	16.95	16.73
			50% Mid	1	16.75	16.99	16.88
			50% High	1	16.81	17.12	16.95
			100%	1	16.71	17.04	16.82
		16-QAM	1RB Low	1	16.53	16.80	16.61
			1RB Mid	1	16.62	16.93	16.76
			1RB High	1	16.82	17.12	16.94
			50% Low	2	16.85	17.16	17.04
			50% Mid	2	16.94	17.21	17.11
			50% High	2	17.08	17.38	17.15
			100%	2	17.02	17.15	16.99

Band	BW	Modulation	Mode	MPR	Average Output Power (dBm)		
					Low CH	Mid CH	High CH
					1851.5 MHz	1880.0 MHz	1908.5 MHz
LTE B2	3 MHz	QPSK	1RB Low	0	16.59	16.73	16.73
			1RB Mid	0	16.75	16.88	16.86
			1RB High	0	16.91	17.06	17.04
			50% Low	1	16.56	16.72	16.68
			50% Mid	1	16.66	16.79	16.76
			50% High	1	16.74	16.91	16.87
			100%	1	16.63	16.79	16.78
		16-QAM	1RB Low	1	16.25	16.40	16.37
			1RB Mid	1	16.43	16.56	16.55
			1RB High	1	16.60	16.71	16.71
			50% Low	2	16.71	16.91	16.85
			50% Mid	2	16.84	16.99	16.93
			50% High	2	16.90	17.08	17.05
			100%	2	16.80	16.84	16.89
Band	BW	Modulation	Mode	MPR	Low CH	Mid CH	High CH
LTE B2	1.4 MHz	QPSK	1RB Low	0	16.67	16.87	16.88
			1RB Mid	0	16.88	17.02	17.02
			1RB High	0	17.03	17.20	17.19
			50% Low	1	16.68	16.84	16.82
			50% Mid	1	16.79	16.91	16.92
			50% High	1	16.88	17.05	17.02
			100%	1	16.76	16.93	16.92
		16-QAM	1RB Low	1	16.37	16.55	16.67
			1RB Mid	1	16.53	16.70	16.87
			1RB High	1	16.70	16.87	17.00
			50% Low	2	16.86	17.01	16.99
			50% Mid	2	16.96	17.14	17.06
			50% High	2	17.05	17.20	17.18
			100%	2	16.84	17.09	17.12

- LTE CAT M1 B4

Band	BW	Modulation	Mode	MPR	Average Output Power (dBm)		
					Low CH	Mid CH	High CH
					1720.0 MHz	1732.5 MHz	1745.0 MHz
LTE B4	20 MHz	QPSK	1RB Low	0	16.57	16.64	16.69
			1RB Mid	0	16.67	16.72	16.78
			1RB High	0	16.88	16.95	16.81
			50% Low	1	16.54	16.59	16.65
			50% Mid	1	16.56	16.64	16.68
			50% High	1	16.65	16.71	16.72
			100%	1	16.62	16.66	16.72
		16-QAM	1RB Low	1	16.59	16.64	16.72
			1RB Mid	1	16.65	16.73	16.82
			1RB High	1	16.91	16.96	17.02
			50% Low	2	16.80	16.86	16.96
			50% Mid	2	16.84	16.91	16.99
			50% High	2	16.92	16.97	17.05
			100%	2	16.84	16.88	16.95
Band	BW	Modulation	Mode	MPR	Low CH	Mid CH	High CH
					1717.5 MHz	1732.5 MHz	1747.5 MHz
LTE B4	15 MHz	QPSK	1RB Low	0	16.55	16.66	16.71
			1RB Mid	0	16.63	16.75	16.78
			1RB High	0	16.86	16.99	17.01
			50% Low	1	16.50	16.62	16.64
			50% Mid	1	16.55	16.68	16.68
			50% High	1	16.62	16.74	16.73
			100%	1	16.58	16.70	16.71
		16-QAM	1RB Low	1	16.55	16.69	16.72
			1RB Mid	1	16.65	16.73	16.81
			1RB High	1	16.88	17.03	17.03
			50% Low	2	16.77	16.91	17.04
			50% Mid	2	16.84	16.97	17.03
			50% High	2	16.90	17.04	17.10
			100%	2	16.79	16.92	16.95

Band	BW	Modulation	Mode	MPR	Average Output Power (dBm)		
					Low CH	Mid CH	High CH
					1715.0 MHz	1732.5MHz	1750.0 MHz
LTE B4	10 MHz	QPSK	1RB Low	0	16.58	16.74	16.71
			1RB Mid	0	16.74	16.89	16.83
			1RB High	0	16.90	17.04	17.00
			50% Low	1	16.55	16.70	16.64
			50% Mid	1	16.62	16.86	16.76
			50% High	1	16.72	16.89	16.82
			100%	1	16.61	16.77	16.71
		16-QAM	1RB Low	1	16.44	16.58	16.53
			1RB Mid	1	16.59	16.75	16.68
			1RB High	1	16.74	16.91	16.82
			50% Low	2	16.77	17.00	16.89
			50% Mid	2	16.85	17.09	16.94
			50% High	2	16.95	17.17	17.07
			100%	2	16.86	16.94	16.93
Band	BW	Modulation	Mode	MPR	Low CH	Mid CH	High CH
					1712.5 MHz	1732.5MHz	1752.5 MHz
LTE B4	5 MHz	QPSK	1RB Low	0	16.54	16.62	16.66
			1RB Mid	0	16.69	16.76	16.80
			1RB High	0	16.86	16.93	16.96
			50% Low	1	16.49	16.58	16.61
			50% Mid	1	16.59	16.62	16.86
			50% High	1	16.68	16.77	16.78
			100%	1	16.56	16.64	16.67
		16-QAM	1RB Low	1	16.39	16.46	16.66
			1RB Mid	1	16.53	16.63	16.81
			1RB High	1	16.72	16.79	16.96
			50% Low	2	16.73	16.84	16.60
			50% Mid	2	16.83	16.96	16.72
			50% High	2	16.92	17.02	16.78
			100%	2	16.75	16.84	16.83

Band	BW	Modulation	Mode	MPR	Average Output Power (dBm)		
					Low CH	Mid CH	High CH
					1711.5 MHz	1732.5MHz	1753.5 MHz
LTE B4	3 MHz	QPSK	1RB Low	0	16.39	16.48	16.37
			1RB Mid	0	16.56	16.64	16.55
			1RB High	0	16.71	16.80	16.72
			50% Low	1	16.36	16.45	16.33
			50% Mid	1	16.44	16.54	16.41
			50% High	1	16.55	16.65	16.53
			100%	1	16.43	16.52	16.41
		16-QAM	1RB Low	1	16.08	16.15	16.39
			1RB Mid	1	16.21	16.30	16.52
			1RB High	1	16.38	16.56	16.68
			50% Low	2	16.53	16.65	16.34
			50% Mid	2	16.63	16.75	16.42
			50% High	2	16.73	16.83	16.54
			100%	2	16.69	16.76	16.62
Band	BW	Modulation	Mode	MPR	Low CH	Mid CH	High CH
					1710.7 MHz	1732.5MHz	1754.3 MHz
LTE B4	1.4 MHz	QPSK	1RB Low	0	16.51	16.61	16.49
			1RB Mid	0	16.67	16.76	16.66
			1RB High	0	16.82	16.94	16.80
			50% Low	1	16.47	16.59	16.47
			50% Mid	1	16.56	16.63	16.53
			50% High	1	16.66	16.75	16.64
			100%	1	16.53	16.65	16.52
		16-QAM	1RB Low	1	16.16	16.31	16.32
			1RB Mid	1	16.31	16.43	16.58
			1RB High	1	16.49	16.61	16.72
			50% Low	2	16.66	16.78	16.77
			50% Mid	2	16.75	16.84	16.85
			50% High	2	16.87	16.95	16.93
			100%	2	16.76	16.84	16.75

- LTE CAT M1 B5

Band	BW	Modulation	Mode	MPR	Average Output Power (dBm)		
					Low CH	Mid CH	High CH
					829.0 MHz	836.5 MHz	844.0 MHz
LTE B5	10 MHz	QPSK	1RB Low	0	17.44	17.53	17.36
			1RB Mid	0	17.51	17.59	17.38
			1RB High	0	17.64	17.72	17.54
			50% Low	1	17.40	17.36	17.29
			50% Mid	1	17.40	17.42	17.36
			50% High	1	17.42	17.49	17.40
			100%	1	17.42	17.43	17.31
		16-QAM	1RB Low	1	17.35	17.32	17.22
			1RB Mid	1	17.35	17.38	17.30
			1RB High	1	17.48	17.52	17.41
			50% Low	2	17.66	17.67	17.57
			50% Mid	2	17.69	17.63	17.65
			50% High	2	17.75	17.62	17.68
			100%	2	17.66	17.62	17.53
Band	BW	Modulation	Mode	MPR	Low CH	Mid CH	High CH
					826.5 MHz	836.5 MHz	846.5 MHz
LTE B5	5 MHz	QPSK	1RB Low	0	17.47	17.44	17.68
			1RB Mid	0	17.50	17.48	17.71
			1RB High	0	17.62	17.61	17.87
			50% Low	1	17.37	17.37	17.71
			50% Mid	1	17.39	17.39	17.70
			50% High	1	17.47	17.41	17.72
			100%	1	17.39	17.39	17.64
		16-QAM	1RB Low	1	17.33	17.31	17.58
			1RB Mid	1	17.34	17.33	17.58
			1RB High	1	17.48	17.48	17.68
			50% Low	2	17.62	17.62	17.89
			50% Mid	2	17.69	17.65	17.96
			50% High	2	17.70	17.66	17.99
			100%	2	17.63	17.53	17.88

Band	BW	Modulation	Mode	MPR	Average Output Power (dBm)		
					Low CH	Mid CH	High CH
					825.5 MHz	836.5 MHz	847.4 MHz
LTE B5	3 MHz	QPSK	1RB Low	0	17.31	17.15	17.57
			1RB Mid	0	17.37	17.22	17.61
			1RB High	0	17.46	17.33	17.72
			50% Low	1	17.27	17.09	17.46
			50% Mid	1	17.30	17.12	17.52
			50% High	1	17.33	17.20	17.59
			100%	1	17.27	17.13	17.51
		16-QAM	1RB Low	1	17.00	17.15	17.21
			1RB Mid	1	17.03	17.20	17.29
			1RB High	1	17.12	17.36	17.40
			50% Low	2	17.41	17.09	17.71
			50% Mid	2	17.45	17.11	17.73
			50% High	2	17.50	17.20	17.78
			100%	2	17.51	17.22	17.76
Band	BW	Modulation	Mode	MPR	Low CH	Mid CH	High CH
LTE B5	1.4 MHz	QPSK	1RB Low	0	17.44	17.18	17.55
			1RB Mid	0	17.46	17.34	17.64
			1RB High	0	17.57	17.48	17.75
			50% Low	1	17.38	17.22	17.49
			50% Mid	1	17.45	17.26	17.53
			50% High	1	17.46	17.32	17.60
			100%	1	17.39	17.25	17.52
		16-QAM	1RB Low	1	17.36	17.03	17.23
			1RB Mid	1	17.15	17.07	17.33
			1RB High	1	17.27	17.15	17.44
			50% Low	2	17.43	17.40	17.67
			50% Mid	2	17.49	17.44	17.73
			50% High	2	17.53	17.50	17.79
			100%	2	17.74	17.49	17.71

- LTE CAT M1 B12

Band	BW	Modulation	Mode	MPR	Average Output Power (dBm)		
					Low CH	Mid CH	High CH
LTE B12	10 MHz	QPSK	1RB Low	0	-	707.5 MHz	-
			1RB Mid	0	-	17.60	-
			1RB High	0	-	17.64	-
			50% Low	1	-	17.77	-
			50% Mid	1	-	17.53	-
			50% High	1	-	17.55	-
			100%	1	-	17.56	-
		16-QAM	1RB Low	1	-	17.59	-
			1RB Mid	1	-	17.29	-
			1RB High	1	-	17.35	-
			50% Low	2	-	17.45	-
			50% Mid	2	-	17.72	-
			50% High	2	-	17.79	-
			100%	2	-	17.85	-
Band	BW	Modulation	Mode	MPR	Low CH	Mid CH	High CH
					701.5 MHz	707.5 MHz	713.5 MHz
LTE B12	5 MHz	QPSK	1RB Low	0	17.69	17.69	17.73
			1RB Mid	0	17.73	17.75	17.78
			1RB High	0	17.88	17.87	17.90
			50% Low	1	17.61	17.61	17.65
			50% Mid	1	17.68	17.68	17.69
			50% High	1	17.73	17.72	17.77
			100%	1	17.65	17.66	17.67
		16-QAM	1RB Low	1	17.55	17.57	17.56
			1RB Mid	1	17.62	17.62	17.64
			1RB High	1	17.75	17.75	17.71
			50% Low	2	17.91	17.88	17.98
			50% Mid	2	17.95	17.92	18.00
			50% High	2	18.00	17.98	18.03
			100%	2	17.86	17.84	17.88

Note: According to KDB941225 D05 SAR for LTE Devices, for LTE bands that do not support at least three non-overlapping channels in certain channel bandwidths, test the available non-overlapping channels instead. When a device supports overlapping channel assignment in a channel bandwidth configuration, the middle channel of the group of overlapping channels should be selected for testing.

Band	BW	Modulation	Mode	MPR	Average Output Power (dBm)		
					Low CH	Mid CH	High CH
					700.5 MHz	707.5 MHz	714.5 MHz
LTE B12	3 MHz	QPSK	1RB Low	0	17.55	17.56	17.46
			1RB Mid	0	17.62	17.59	17.51
			1RB High	0	17.77	17.73	17.63
			50% Low	1	17.49	17.51	17.40
			50% Mid	1	17.55	17.76	17.45
			50% High	1	17.60	17.59	17.51
			100%	1	17.51	17.52	17.44
		16-QAM	1RB Low	1	17.25	17.52	17.16
			1RB Mid	1	17.30	17.60	17.23
			1RB High	1	17.43	17.75	17.33
			50% Low	2	17.68	17.48	17.60
			50% Mid	2	17.71	17.53	17.66
			50% High	2	17.79	17.54	17.72
			100%	2	17.52	17.69	17.63
Band	BW	Modulation	Mode	MPR	Low CH	Mid CH	High CH
					699.7 MHz	707.5 MHz	715.3 MHz
LTE B12	1.4 MHz	QPSK	1RB Low	0	17.65	17.79	17.63
			1RB Mid	0	17.70	17.73	17.66
			1RB High	0	17.86	17.86	17.81
			50% Low	1	17.58	17.63	17.58
			50% Mid	1	17.62	17.69	17.63
			50% High	1	17.73	17.74	17.64
			100%	1	17.60	17.69	17.56
		16-QAM	1RB Low	1	17.33	17.69	17.37
			1RB Mid	1	17.37	17.73	17.36
			1RB High	1	17.51	17.88	17.49
			50% Low	2	17.77	17.66	17.73
			50% Mid	2	17.84	17.73	17.81
			50% High	2	17.94	17.76	17.86
			100%	2	17.79	17.93	17.76

- LTE CAT M1 B13

Band	BW	Modulation	Mode	MPR	Average Output Power (dBm)		
					Low CH	Mid CH	High CH
					-	782.0 MHz	-
LTE B13	10 MHz	QPSK	1RB Low	0	-	17.28	-
			1RB Mid	0	-	17.35	-
			1RB High	0	-	17.45	-
			50% Low	1	-	17.22	-
			50% Mid	1	-	17.31	-
			50% High	1	-	17.36	-
			100%	1	-	17.27	-
		16-QAM	1RB Low	1	-	17.18	-
			1RB Mid	1	-	17.25	-
			1RB High	1	-	17.27	-
			50% Low	2	-	17.49	-
			50% Mid	2	-	17.59	-
			50% High	2	-	17.60	-
			100%	2	-	17.62	-
Band	BW	Modulation	Mode	MPR	Low CH	Mid CH	High CH
					779.5 MHz	782.0 MHz	784.5 MHz
LTE B13	5 MHz	QPSK	1RB Low	0	-	17.27	-
			1RB Mid	0	-	17.32	-
			1RB High	0	-	17.48	-
			50% Low	1	-	17.26	-
			50% Mid	1	-	17.32	-
			50% High	1	-	17.35	-
			100%	1	-	17.28	-
		16-QAM	1RB Low	1	-	17.16	-
			1RB Mid	1	-	17.25	-
			1RB High	1	-	17.38	-
			50% Low	2	-	17.54	-
			50% Mid	2	-	17.52	-
			50% High	2	-	17.56	-
			100%	2	-	17.53	-

Note: According to KDB941225 D05 SAR for LTE Devices, for LTE bands that do not support at least three non-overlapping channels in certain channel bandwidths, test the available non-overlapping channels instead. When a device supports overlapping channel assignment in a channel bandwidth configuration, the middle channel of the group of overlapping channels should be selected for testing.

- LTE CAT M1 B25

Band	BW	Modulation	Mode	MPR	Average Output Power (dBm)		
					Low CH	Mid CH	High CH
					1860.0 MHz	1882.5 MHz	1905.0 MHz
LTE B25	20 MHz	QPSK	1RB Low	0	16.77	16.93	16.80
			1RB Mid	0	16.86	16.99	16.88
			1RB High	0	17.07	17.25	17.11
			50% Low	1	16.71	16.89	16.74
			50% Mid	1	16.76	16.95	16.81
			50% High	1	16.83	17.01	16.84
			100%	1	16.78	16.99	16.82
		16-QAM	1RB Low	1	16.74	16.91	16.77
			1RB Mid	1	16.81	17.00	16.83
			1RB High	1	17.05	17.23	17.08
			50% Low	2	16.95	17.14	17.04
			50% Mid	2	16.99	17.18	17.08
			50% High	2	17.05	17.26	17.16
			100%	2	16.97	17.16	17.02
Band	BW	Modulation	Mode	MPR	Low CH	Mid CH	High CH
					1857.5 MHz	1882.5 MHz	1907.5 MHz
LTE B25	15 MHz	QPSK	1RB Low	0	17.85	16.88	16.79
			1RB Mid	0	17.95	16.99	16.88
			1RB High	0	18.18	17.23	17.10
			50% Low	1	17.82	16.85	16.74
			50% Mid	1	17.85	16.91	16.79
			50% High	1	17.90	16.97	16.81
			100%	1	17.92	16.93	16.81
		16-QAM	1RB Low	1	17.84	16.90	16.78
			1RB Mid	1	17.93	16.95	16.82
			1RB High	1	18.14	17.22	17.08
			50% Low	2	18.00	17.13	17.09
			50% Mid	2	18.09	17.18	17.08
			50% High	2	18.13	17.24	17.13
			100%	2	18.13	17.13	17.05

Band	BW	Modulation	Mode	MPR	Average Output Power (dBm)		
					Low CH	Mid CH	High CH
					1855.0 MHz	1882.5 MHz	1910.0 MHz
LTE B25	10 MHz	QPSK	1RB Low	0	16.74	16.83	16.82
			1RB Mid	0	16.84	17.00	16.98
			1RB High	0	17.05	17.16	17.10
			50% Low	1	16.67	16.80	16.78
			50% Mid	1	16.72	16.89	16.83
			50% High	1	16.86	16.99	16.99
			100%	1	16.74	16.88	16.85
		16-QAM	1RB Low	1	16.55	16.68	16.66
			1RB Mid	1	16.69	16.74	16.83
			1RB High	1	16.85	17.00	16.97
			50% Low	2	16.89	17.01	17.01
			50% Mid	2	16.98	17.11	17.16
			50% High	2	17.08	17.21	17.21
			100%	2	16.91	17.02	17.06
Band	BW	Modulation	Mode	MPR	Low CH	Mid CH	High CH
					1852.5 MHz	1882.2 MHz	1912.5 MHz
LTE B25	5 MHz	QPSK	1RB Low	0	16.69	16.85	16.87
			1RB Mid	0	16.75	17.01	17.03
			1RB High	0	17.00	17.13	17.20
			50% Low	1	16.64	16.88	16.83
			50% Mid	1	16.75	16.96	16.89
			50% High	1	16.84	17.02	16.99
			100%	1	16.69	16.88	16.90
		16-QAM	1RB Low	1	16.52	16.68	16.71
			1RB Mid	1	16.69	16.82	16.74
			1RB High	1	16.85	16.99	16.99
			50% Low	2	16.86	17.05	17.05
			50% Mid	2	16.95	17.16	17.12
			50% High	2	17.04	17.25	17.23
			100%	2	16.85	17.04	17.03

Band	BW	Modulation	Mode	MPR	Average Output Power (dBm)		
					Low CH	Mid CH	High CH
					1851.5 MHz	1882.5 MHz	1913.5 MHz
LTE B25	3 MHz	QPSK	1RB Low	0	16.54	16.82	16.73
			1RB Mid	0	16.69	16.82	16.87
			1RB High	0	16.84	16.99	17.09
			50% Low	1	16.51	16.70	16.81
			50% Mid	1	16.59	16.79	16.92
			50% High	1	16.61	16.85	16.91
			100%	1	16.58	16.77	16.79
		16-QAM	1RB Low	1	16.22	16.38	16.41
			1RB Mid	1	16.37	16.55	16.60
			1RB High	1	16.55	16.72	16.74
			50% Low	2	16.66	16.90	16.87
			50% Mid	2	16.73	16.98	16.98
			50% High	2	16.78	17.06	17.10
			100%	2	16.72	16.95	16.93
Band	BW	Modulation	Mode	MPR	Low CH	Mid CH	High CH
					1850.7 MHz	1882.5 MHz	1914.3 MHz
LTE B25	1.4 MHz	QPSK	1RB Low	0	16.65	16.88	16.54
			1RB Mid	0	16.82	17.03	16.68
			1RB High	0	16.97	17.20	16.86
			50% Low	1	16.63	16.83	17.01
			50% Mid	1	16.69	16.96	17.14
			50% High	1	16.83	17.03	17.20
			100%	1	16.69	16.92	16.90
		16-QAM	1RB Low	1	16.33	16.53	16.49
			1RB Mid	1	16.50	16.70	16.67
			1RB High	1	16.76	16.87	16.80
			50% Low	2	16.76	17.00	17.01
			50% Mid	2	16.86	17.08	17.00
			50% High	2	16.93	17.19	17.05
			100%	2	16.84	17.06	17.08

- LTE CAT M1 B26

Band	BW	Modulation	Mode	MPR	Average Output Power (dBm)		
					Low CH	Mid CH	High CH
					-	831.5 MHz	-
LTE B26	15 MHz	QPSK	1RB Low	0	-	17.52	-
			1RB Mid	0	-	17.64	-
			1RB High	0	-	17.75	-
			50% Low	1	-	17.41	-
			50% Mid	1	-	17.49	-
			50% High	1	-	17.51	-
			100%	1	-	17.44	-
		16-QAM	1RB Low	1	-	17.32	-
			1RB Mid	1	-	17.40	-
			1RB High	1	-	17.53	-
			50% Low	2	-	17.67	-
			50% Mid	2	-	17.72	-
			50% High	2	-	17.74	-
100%	2	-	17.68	-			
Band	BW	Modulation	Mode	MPR	Low CH	Mid CH	High CH
					819.0 MHz	831.5 MHz	844.0 MHz
LTE B26	10 MHz	QPSK	1RB Low	0	17.58	17.29	17.24
			1RB Mid	0	17.73	17.34	17.29
			1RB High	0	17.75	17.46	17.44
			50% Low	1	17.50	17.22	17.16
			50% Mid	1	17.59	17.29	17.21
			50% High	1	17.61	17.32	17.28
			100%	1	17.52	17.24	17.20
		16-QAM	1RB Low	1	17.44	17.28	17.09
			1RB Mid	1	17.49	17.32	17.12
			1RB High	1	17.61	17.45	17.28
			50% Low	2	17.75	17.25	17.43
			50% Mid	2	17.84	17.32	17.49
			50% High	2	17.85	17.36	17.52
100%	2	17.74	17.46	17.41			

Note: According to KDB941225 D05 SAR for LTE Devices, for LTE bands that do not support at least three non-overlapping channels in certain channel bandwidths, test the available non-overlapping channels instead. When a device supports overlapping channel assignment in a channel bandwidth configuration, the middle channel of the group of overlapping channels should be selected for testing.

Band	BW	Modulation	Mode	MPR	Average Output Power (dBm)		
					Low CH	Mid CH	High CH
					816.5 MHz	831.5 MHz	846.5 MHz
LTE B26	5 MHz	QPSK	1RB Low	0	17.53	17.25	17.63
			1RB Mid	0	17.57	17.32	17.66
			1RB High	0	17.70	17.43	17.84
			50% Low	1	17.44	17.20	17.53
			50% Mid	1	17.49	17.28	17.59
			50% High	1	17.56	17.33	17.68
			100%	1	17.52	17.23	17.66
		16-QAM	1RB Low	1	17.40	17.18	17.46
			1RB Mid	1	17.45	17.14	17.64
			1RB High	1	17.59	17.35	17.68
			50% Low	2	17.72	17.50	17.85
			50% Mid	2	17.77	17.51	17.92
			50% High	2	17.82	17.55	17.93
			100%	2	17.78	17.42	17.81
Band	BW	Modulation	Mode	MPR	Low CH	Mid CH	High CH
					815.5 MHz	831.5 MHz	847.5 MHz
LTE B26	3 MHz	QPSK	1RB Low	0	17.68	17.35	17.74
			1RB Mid	0	17.70	17.40	17.73
			1RB High	0	17.81	17.57	17.92
			50% Low	1	17.59	17.32	17.65
			50% Mid	1	17.63	17.39	17.72
			50% High	1	17.67	17.42	17.75
			100%	1	17.64	17.35	17.68
		16-QAM	1RB Low	1	17.58	17.23	17.57
			1RB Mid	1	17.59	17.26	17.67
			1RB High	1	17.68	17.31	17.80
			50% Low	2	17.87	17.70	17.95
			50% Mid	2	17.93	17.68	18.00
			50% High	2	17.97	17.66	18.06
			100%	2	17.81	17.56	17.89
Band	BW	Modulation	Mode	MPR	Low CH	Mid CH	High CH
					814.5 MHz	831.5 MHz	848.3 MHz
LTE B26	1.4 MHz	QPSK	1RB Low	0	17.72	17.42	17.74
			1RB Mid	0	17.77	17.46	17.81
			1RB High	0	17.89	17.57	17.91
			50% Low	1	17.66	17.33	17.68
			50% Mid	1	17.65	17.39	17.73
			50% High	1	17.69	17.45	17.79
			100%	1	17.71	17.35	17.71
		16-QAM	1RB Low	1	17.62	17.27	17.59
			1RB Mid	1	17.64	17.32	17.67
			1RB High	1	17.73	17.44	17.81
			50% Low	2	17.93	17.61	17.96
			50% Mid	2	17.99	17.65	17.99
			50% High	2	18.03	17.68	18.04
			100%	2	17.72	17.59	17.96

- LTE CAT M1 B66

Band	BW	Modulation	Mode	MPR	Average Output Power (dBm)		
					Low CH	Mid CH	High CH
					1720.0 MHz	1745.0 MHz	1770.0 MHz
LTE B66	20 MHz	QPSK	1RB Low	0	16.60	16.77	16.54
			1RB Mid	0	16.67	16.84	16.62
			1RB High	0	16.90	17.06	16.86
			50% Low	1	16.57	16.70	16.53
			50% Mid	1	16.60	16.76	16.65
			50% High	1	16.69	16.80	16.74
			100%	1	16.63	16.80	16.57
		16-QAM	1RB Low	1	16.62	16.77	16.55
			1RB Mid	1	16.69	16.89	16.65
			1RB High	1	16.93	17.08	16.86
			50% Low	2	16.81	17.00	16.78
			50% Mid	2	16.86	17.07	16.80
			50% High	2	16.95	17.13	16.88
			100%	2	16.88	17.00	16.77
Band	BW	Modulation	Mode	MPR	Low CH	Mid CH	High CH
					1717.5 MHz	1745.0 MHz	1772.5 MHz
LTE B66	15 MHz	QPSK	1RB Low	0	16.66	16.77	16.53
			1RB Mid	0	16.73	16.86	16.63
			1RB High	0	16.96	17.10	16.86
			50% Low	1	16.60	16.74	16.49
			50% Mid	1	16.65	16.78	16.53
			50% High	1	16.72	16.85	16.62
			100%	1	16.66	16.82	16.57
		16-QAM	1RB Low	1	16.67	16.80	16.55
			1RB Mid	1	16.75	16.89	16.64
			1RB High	1	16.99	17.11	16.88
			50% Low	2	16.90	17.01	16.82
			50% Mid	2	16.94	17.06	16.84
			50% High	2	17.01	17.13	16.91
			100%	2	16.89	17.04	16.79

Band	BW	Modulation	Mode	MPR	Average Output Power (dBm)		
					Low CH	Mid CH	High CH
					1715.0 MHz	1745.0 MHz	1775.0 MHz
LTE B66	10 MHz	QPSK	1RB Low	0	16.61	16.78	16.72
			1RB Mid	0	16.75	16.92	16.87
			1RB High	0	16.90	17.07	16.99
			50% Low	1	16.55	16.71	16.67
			50% Mid	1	16.64	16.79	16.76
			50% High	1	16.75	16.90	16.87
			100%	1	16.65	16.79	16.74
		16-QAM	1RB Low	1	16.46	16.62	16.56
			1RB Mid	1	16.61	16.77	16.72
			1RB High	1	16.78	16.91	16.88
			50% Low	2	16.80	17.00	16.94
			50% Mid	2	16.85	17.14	17.02
			50% High	2	16.99	17.14	17.12
			100%	2	16.63	16.86	16.92
Band	BW	Modulation	Mode	MPR	Low CH	Mid CH	High CH
					1712.5 MHz	1745.0 MHz	1777.5 MHz
LTE B66	5 MHz	QPSK	1RB Low	0	16.58	16.73	16.75
			1RB Mid	0	16.73	16.87	16.90
			1RB High	0	16.89	17.03	17.07
			50% Low	1	16.55	16.69	16.72
			50% Mid	1	16.63	16.78	16.82
			50% High	1	16.71	16.81	16.89
			100%	1	16.59	16.75	16.77
		16-QAM	1RB Low	1	16.57	16.58	16.60
			1RB Mid	1	16.73	16.74	16.74
			1RB High	1	16.88	16.88	16.88
			50% Low	2	16.51	17.00	16.94
			50% Mid	2	16.62	17.10	16.99
			50% High	2	16.71	17.13	17.13
			100%	2	16.75	16.91	17.01

- LTE CAT M1 B71

Band	BW	Modulation	Mode	MPR	Average Output Power (dBm)		
					Low CH	Mid CH	High CH
					673.0 MHz	680.5 MHz	688.0 MHz
LTE B71	20 MHz	QPSK	1RB Low	0	17.41	17.34	17.31
			1RB Mid	0	17.44	17.35	17.33
			1RB High	0	17.60	17.50	17.47
			50% Low	1	17.35	17.25	17.22
			50% Mid	1	17.36	17.26	17.23
			50% High	1	17.43	17.29	17.28
			100%	1	17.42	17.29	17.29
		16-QAM	1RB Low	1	17.42	17.35	17.33
			1RB Mid	1	17.44	17.39	17.34
			1RB High	1	17.58	17.51	17.53
			50% Low	2	17.63	17.54	17.54
			50% Mid	2	17.62	17.55	17.55
			50% High	2	17.70	17.59	17.60
			100%	2	0.00	17.54	17.50
Band	BW	Modulation	Mode	MPR	Low CH	Mid CH	High CH
					670.5 MHz	680.5 MHz	690.5 MHz
LTE B71	15 MHz	QPSK	1RB Low	0	17.40	17.27	17.18
			1RB Mid	0	17.41	17.28	17.18
			1RB High	0	17.60	17.47	17.33
			50% Low	1	17.31	17.21	17.09
			50% Mid	1	17.36	17.22	17.10
			50% High	1	17.38	17.28	17.09
			100%	1	17.39	17.24	17.11
		16-QAM	1RB Low	1	17.41	17.28	17.18
			1RB Mid	1	17.46	17.29	17.19
			1RB High	1	17.62	17.51	17.37
			50% Low	2	17.64	17.51	17.46
			50% Mid	2	17.67	17.52	17.46
			50% High	2	17.69	17.56	17.51
			100%	2	17.62	17.47	17.36

Band	BW	Modulation	Mode	MPR	Average Output Power (dBm)		
					Low CH	Mid CH	High CH
					668.0 MHz	680.5 MHz	693.0 MHz
LTE B71	10 MHz	QPSK	1RB Low	0	17.40	17.33	17.32
			1RB Mid	0	17.42	17.37	17.39
			1RB High	0	17.59	17.50	17.55
			50% Low	1	17.33	17.24	17.26
			50% Mid	1	17.39	17.43	17.32
			50% High	1	17.42	17.35	17.39
			100%	1	17.36	17.27	17.21
		16-QAM	1RB Low	1	17.26	17.16	17.17
			1RB Mid	1	17.29	17.24	17.22
			1RB High	1	17.42	17.36	17.39
			50% Low	2	17.55	17.52	17.56
			50% Mid	2	17.62	17.61	17.62
			50% High	2	17.65	17.61	17.63
			100%	2	17.52	17.44	17.46
Band	BW	Modulation	Mode	MPR	Low CH	Mid CH	High CH
LTE B71	5 MHz	QPSK	1RB Low	0	17.32	17.24	17.31
			1RB Mid	0	17.38	17.29	17.32
			1RB High	0	17.58	17.43	17.49
			50% Low	1	17.27	17.26	17.20
			50% Mid	1	17.36	17.29	17.31
			50% High	1	17.40	17.28	17.35
			100%	1	17.36	17.19	17.25
		16-QAM	1RB Low	1	17.25	17.11	17.14
			1RB Mid	1	17.30	17.16	17.21
			1RB High	1	17.40	17.30	17.35
			50% Low	2	17.59	17.44	17.52
			50% Mid	2	17.63	17.49	17.65
			50% High	2	17.67	17.53	17.61
			100%	2	17.59	17.46	17.48

- LTE B2

SAR for LTE Band 2 has not been measured because it is covered by LTE Band 25 due to overlapping frequency range (LTE Band 2 frequency range: 1850 – 1910 MHz, LTE Band 25 frequency range: 1850 – 1915 MHz) and same maximum tune-up and channel bandwidth.

- LTE B4

SAR for LTE Band 4 has not been measured because it is covered by LTE Band 66 due to overlapping frequency range (LTE Band 4 frequency range: 1710 – 1755 MHz, LTE Band 66 frequency range: 1710 – 1780 MHz) and same maximum tune-up and channel bandwidth.

- LTE B5

SAR for LTE Band 5 has not been measured because it is covered by LTE Band 26 due to overlapping frequency range (LTE Band 5 frequency range: 824 – 849 MHz, LTE Band 26 frequency range: 814 – 849 MHz) and same maximum tune-up and channel bandwidth.

2.2. BLUETOOTH ANTENNA

Band	Mode	Channel / Freq (MHz)	Average Output Power (dBm)
2.4 GHz	Bluetooth LE	0 / 2402	0.0
		19 / 2440	
		39 / 2480	

According to ISED RSS-102 Issue 5 (2015-03) – Radio Frequency Exposure Compliance of Radiocommunication Apparatus (All Frequency Bands), paragraph 2.5.1 Exemption Limits for Routine Evaluation – SAR Evaluation, if the device operates below the applicable output power level (adjusted for tune-up tolerance), for the specified separation distance defined in Table 1, SAR evaluation is not required . Output power level shall be the higher of the maximum conducted or equivalent isotropically radiated power (e.i.r.p.) source-based, time-averaged output power.

The DUT has an antenna with a gain of 3.31 dBi, so the isotropically radiated power (e.i.r.p.) source-based, time-averaged output power is 3.31 dBm → 2.14 mW:

$$\text{Output power level (e.i.r.p.)} = 2.14 \text{ mW} < 15 \text{ mW (Exemption limit at 2450MHz frequency, 15 mm distance)}$$

Therefore SAR testing is not needed according to ISED RSS-102 Issue 5 (2015-03).

As the device supports simultaneous transmission using this technology, the estimate SAR value must be calculated according to Notice 2016-DRS001, based the following equation:

(maximum power level including tune-up tolerance for transmitter A / maximum power level of exemption at the same frequency and distance) * 0.4W/kg

$$\text{Bluetooth Estimated SAR} = (2.14\text{mW}/15\text{mW}) * 0.4 \text{ W/kg} = 0.06 \text{ W/kg}$$

3. TISSUE PARAMETERS MEASUREMENTS

Frequency (MHz)	Target Head Tissue		Measured Head Tissue		Deviation %		Measured Date
	Permittivity ϵ	Conductivity σ [S/m]	Permittivity ϵ	Conductivity σ [S/m]	Permittivity ϵ	Conductivity σ [S/m]	
750	41.94	0.89	42.09	0.90	0.37	0.82	2022-10-25
750	41.94	0.89	42.68	0.91	1.77	1.47	2022-11-29
835	41.55	0.91	41.76	0.93	0.50	1.99	2022-10-26
900	41.50	0.97	41.66	0.95	0.38	-2.10	2022-10-26
1750	40.07	1.37	40.17	1.34	0.25	-2.08	2022-10-26
1800	40.00	1.40	40.03	1.37	0.08	-2.12	2022-10-26
1900	40.00	1.40	39.78	1.42	-0.54	1.44	2022-10-26

Frequency (MHz)	Target Body Tissue		Measured Body Tissue		Deviation %		Measured Date
	Permittivity ϵ	Conductivity σ [S/m]	Permittivity ϵ	Conductivity σ [S/m]	Permittivity ϵ	Conductivity σ [S/m]	
750	55.5	0.96	54.66	0.97	-1.57	0.70	2022-11-07
750	55.5	0.96	54.07	0.97	-2.62	0.92	2022-11-28
835	55.21	0.98	54.30	0.97	-1.64	-1.40	2022-11-08
900	55.0	1.05	53.75	1.04	-2.28	-0.95	2022-11-08
1750	53.4	1.49	53.37	1.49	-0.12	-0.08	2022-11-09
1800	53.3	1.52	53.17	1.52	-0.23	-0.27	2022-11-09
1900	53.3	1.52	52.72	1.55	-1.08	1.93	2022-11-09

Note: The dielectric properties have been measured by the contact probe method at 22° C.

- Composition / Information on ingredients

Head and Muscle Tissue Simulation Liquids HSL750V2/MSL750V2

Water	Water, 35 – 58%
Sucrose	Sugar, white, refined, 40 – 60%
NaCl	Sodium Chloride, 0 – 6%
Hydroxyethyl-cellulose Medium	Viscosity (CAS# 9004-62-0), <0.3%
Preventol-D7	Preservative: aqueous preparation, (CAS# 55965-84-9), containing 5-chloro-2-methyl-3(2H)-isothiazolone and 2-methyl-3(2H)-isothiazolone, 0.1 – 0.7%

Head and Muscle Tissue Simulation Liquids HSL900/MSL900

Water	Water, 35 – 58%
Sucrose	Sugar, white, refined, 40 – 60%
NaCl	Sodium Chloride, 0 – 6%
Hydroxyethyl-cellulose	Medium Viscosity (CAS# 9004-62-0), <0.3%
Preventol-D7	Preservative: aqueous preparation, (CAS# 55965-84-9), containing 5-chloro-2-methyl-3(2H)-isothiazolone and 2-methyl-3(2H)-isothiazolone, 0.1 – 0.7%

Head and Muscle Tissue Simulation Liquids HBBL1550-1900V3/MBBL1550-1900V3

Water	50 – 73 %
Non-ionic detergents	27 – 50 % polyoxyethylenesorbitan monolaurate
NaCl	0 – 2 %
Preservative	0.05 – 0.1% Preventol-D7
Safety relevant ingredients:	
CAS-No. 55965-84-9	< 0.1 % aqueous preparation, containing 5-chloro-2-methyl-3(2H)-isothiazolone and 2-methyl-3(2H)-isothiazolone
CAS-No. 9005-64-5	<50 % polyoxyethylenesorbitan monolaurate

Head Tissue Simulation Liquids HBBL600-6000V6

Aqueous solution with surfactants and inhibitors, exact percentage concentration of components is withheld as a trade secret by the manufacturer. Contains:

Ehtanediol	<5.2 %
Sodium petroleum sulfonate	<2.9 %
Hexylene Glycol / 2 – Methyl-pentane-2,4-diol	<2.9 %
Alkoxylated alcohol, > C ₁₆	<2.0 %

4. SYSTEM CHECK MEASUREMENTS

4.1. Validation results for Head TSL

Date	Frequency (MHz)	SAR over	Estimated SAR (W/kg)	SAR (W/kg)	1 W Target SAR (W/kg)	1 W Norm. SAR (W/kg)	Drift (%)
2022/10/25	750	1 gr.	2.24	2.18	8.43	8.69	3.08
		10 gr.	1.49	1.42	5.51	5.66	2.73
2022/11/29	750	1 gr.	2.13	2.06	8.43	8.27	-1.92
		10 gr.	1.44	1.36	5.51	5.46	-0.93
2022/10/26	900	1 gr.	2.82	2.77	11.10	11.04	-0.52
		10 gr.	1.83	1.78	7.07	7.10	0.36
2022/10/26	1800	1 gr.	9.77	9.56	39.30	38.51	-2.02
		10 gr.	5.10	4.95	20.40	19.54	-2.27

4.2. Validation results for Body TSL

Date	Frequency (MHz)	SAR over	Estimated SAR (W/kg)	SAR (W/kg)	1 W Target SAR (W/kg)	1 W Norm. SAR (W/kg)	Drift (%)
2022/11/07	750	1 gr.	2.29	2.27	8.78	9.13	4.01
		10 gr.	1.52	1.50	5.81	6.03	3.87
2022/11/28	750	1 gr.	2.22	2.15	8.78	8.60	-2.05
		10 gr.	1.50	1.42	5.81	5.68	-2.24
2022/11/08	900	1 gr.	2.84	2.81	11.30	11.20	-0.87
		10 gr.	1.84	1.82	7.29	7.25	-0.48
2022/11/09	1800	1 gr.	10.01	9.78	38.80	39.26	1.17
		10 gr.	5.19	5.09	20.40	20.43	0.15

5. MEASUREMENT RESULTS FOR SAR (SPECIFIC ABSORPTION RATE)

5.1. Summary maximum results for head measurements.

Mode	Side / Position	Channel (Frequency)	Reported SAR 1-g (W/kg)	Limit SAR 1-g (W/kg)
LTE CAT M1 Band 12	Top edge/15 mm	CH 23095 (707.5 MHz)	0.206	1.6
LTE CAT M1 Band 13	Top edge/15 mm	CH 23230 (782 MHz)	0.197	1.6
LTE CAT M1 Band 25	Top edge/15 mm	CH 26140 (1860.0 MHz)	0.314	1.6
LTE CAT M1 Band 26	Top edge/15 mm	CH 26865 (831.5 MHz)	0.120	1.6
LTE CAT M1 Band 66	Top edge/15 mm	CH 132575 (1770.0 MHz)	0.434	1.6
LTE CAT M1 Band 71	Top edge/15 mm	CH 133471 (688.0 MHz)	0.150	1.6
BTLE	Estimated SAR	-	0.06	1.6

5.2. Summary maximum results for body measurements.

Mode	Side / Position	Channel (Frequency)	Reported SAR 1-g (W/kg)	Limit SAR 1-g (W/kg)
LTE CAT M1 Band 12	Top edge/15 mm	CH 23095 (707.5 MHz)	0.201	1.6
LTE CAT M1 Band 13	Top edge/15 mm	CH 23230 (782 MHz)	0.208	1.6
LTE CAT M1 Band 25	Top edge/15 mm	CH 26140 (1860.0 MHz)	0.349	1.6
LTE CAT M1 Band 26	Top edge/15 mm	CH 26865 (831.5 MHz)	0.142	1.6
LTE CAT M1 Band 66	Top edge/15 mm	CH 132575 (1770.0 MHz)	0.503	1.6
LTE CAT M1 Band 71	Top edge/15 mm	CH 133471 (688.0 MHz)	0.187	1.6
BTLE	Estimated SAR	-	0.06	1.6

Summary maximum simultaneous multi-band transmission

Transmission Mode	Band	Reported SAR 1-g (W/kg)	Σ SAR _i (W/kg)	Limit SAR 1-g (W/kg)	Verdict
LTE CAT M1 Band 66 (Body Exposure)	1800 MHz	0.503	0.563	1.6	Pass
Bluetooth LE (Estimated SAR)	2.4GHz	0.06			

5.3. Results for LTE CAT M1 Band 12 (1 Rb, 10 MHz, QPSK).

Note: According to KDB941225 D05 SAR for LTE Devices, for LTE bands that do not support at least three non-overlapping channels in certain channel bandwidths, the middle channel of the group of overlapping channels should be selected for testing.

- **Head measurements**

Position	Dist (mm)	Channel (Frequency)	Estimated SAR 1-g (W/kg)	SAR 1-g (W/kg)	Power Drift (%)	Scale factor	Reported SAR 1-g (W/kg)	Plot No.	
Front Face	15	CH 23095 (707.5 MHz)	0.010	NM ¹	3.276	1.570	0.016		
Back Face	45	CH 23095 (707.5 MHz)	0.009	NM ¹	2.094	1.570	0.014		
Left Edge	15	CH 23095 (707.5 MHz)	0.003	NM ¹	1.042	1.570	0.004		
Right Edge	15	CH 23095 (707.5 MHz)	0.001	NM ¹	2.212	1.570	0.001		
Top Edge	15	CH 23095 (707.5 MHz)	0.127	0.128	-1.486	1.570	0.201		
Bottom Edge	15	CH 23095 (707.5 MHz)	NM ²						

1 and 2: See Remarks and Comments

- **Body measurements**

Position	Dist (mm)	Channel (Frequency)	Estimated SAR 1-g (W/kg)	SAR 1-g (W/kg)	Power Drift (%)	Scale factor	Reported SAR 1-g (W/kg)	Plot No.	
Front Face	15	CH 23095 (707.5 MHz)	0.010	NM ¹	-0.230	1.570	0.016		
Back Face	45	CH 23095 (707.5 MHz)	0.011	NM ¹	4.112	1.570	0.017		
Left Edge	15	CH 23095 (707.5 MHz)	0.003	NM ¹	-0.803	1.570	0.005		
Right Edge	15	CH 23095 (707.5 MHz)	0.001	NM ¹	3.872	1.570	0.002		
Top Edge	15	CH 23095 (707.5 MHz)	0.119	0.125	0.925	1.570	0.196		
Bottom Edge	15	CH 23095 (707.5 MHz)	NM ²						

1 and 2: See Remarks and Comments

5.4. Results for LTE CAT M1 Band 12 (50% Rb, 10 MHz, QPSK).

- Head measurements

Position	Dist (mm)	Channel (Frequency)	Estimated SAR 1-g (W/kg)	SAR 1-g (W/kg)	Power Drift (%)	Scale factor	Reported SAR 1-g (W/kg)	Plot No.
Top Edge	15	CH 23095 (707.5 MHz)	0.121	0.125	-0.574	1.648	0.206	1

- Body measurements

Position	Dist (mm)	Channel (Frequency)	Estimated SAR 1-g (W/kg)	SAR 1-g (W/kg)	Power Drift (%)	Scale factor	Reported SAR 1-g (W/kg)	Plot No.
Top Edge	15	CH 23095 (707.5 MHz)	0.118	0.122	0.115	1.648	0.201	2

5.5. Results for LTE CAT M1 Band 13 (1 Rb, 10 MHz, QPSK).

Note: According to KDB941225 D05 SAR for LTE Devices, for LTE bands that do not support at least three non-overlapping channels in certain channel bandwidths, the middle channel of the group of overlapping channels should be selected for testing.

- **Head measurements**

Position	Dist (mm)	Channel (Frequency)	Estimated SAR 1-g (W/kg)	SAR 1-g (W/kg)	Power Drift (%)	Scale factor	Reported SAR 1-g (W/kg)	Plot No.	
Front Face	15	CH 23230 (782 MHz)	0.015	NM ¹	-1.825	1.690	0.025		
Back Face	45	CH 23230 (782 MHz)	0.015	NM ¹	1.391	1.690	0.025		
Left Edge	15	CH 23230 (782 MHz)	0.003	NM ¹	-0.459	1.690	0.005		
Right Edge	15	CH 23230 (782 MHz)	0.001	NM ¹	0.000 ³	1.690	0.002		
Top Edge	15	CH 23230 (782 MHz)	0.113	0.115	-0.345	1.690	0.194		
Bottom Edge	15	CH 23230 (782 MHz)	NM ²						

1, 2 and 3: See remarks and comments

- **Body measurements**

Position	Dist (mm)	Channel (Frequency)	Estimated SAR 1-g (W/kg)	SAR 1-g (W/kg)	Power Drift (%)	Scale factor	Reported SAR 1-g (W/kg)	Plot No.	
Front Face	15	CH 23230 (782 MHz)	0.017	NM ¹	0.462	1.690	0.029		
Back Face	45	CH 23230 (782 MHz)	0.020	NM ¹	0.000 ³	1.690	0.034		
Left Edge	15	CH 23230 (782 MHz)	0.003	NM ¹	-6.889 ³	1.690	0.005		
Right Edge	15	CH 23230 (782 MHz)	0.000 ³	NM ¹	0.000 ³	1.690	0.000		
Top Edge	15	CH 23230 (782 MHz)	0.119	0.123	-0.803	1.690	0.208	4	
Bottom Edge	15	CH 23230 (782 MHz)	NM ²						

1, 2 and 3: See remarks and comments

5.6. Results for LTE CAT M1 Band 13 (50% Rb, 10 MHz, QPSK).

- Head measurements

Position	Dist (mm)	Channel (Frequency)	Estimated SAR 1-g (W/kg)	SAR 1-g (W/kg)	Power Drift (%)	Scale factor	Reported SAR 1-g (W/kg)	Plot No.
Top Edge	15	CH 23230 (782 MHz)	0.111	0.114	0.231	1.726	0.197	3

- Body measurements

Position	Dist (mm)	Channel (Frequency)	Estimated SAR 1-g (W/kg)	SAR 1-g (W/kg)	Power Drift (%)	Scale factor	Reported SAR 1-g (W/kg)	Plot No.
Top Edge	15	CH 23230 (782 MHz)	0.113	0.118	1.042	1.726	0.204	

5.7. Results for LTE CAT M1 Band 25 (1 Rb, 20 MHz, QPSK).

- Head measurements

Position	Dist (mm)	Channel (Frequency)	Estimated SAR 1-g (W/kg)	SAR 1-g (W/kg)	Power Drift (%)	Scale factor	Reported SAR 1-g (W/kg)	Plot No.	
Front Face	15	CH 26365 (1882.5 MHz)	0.039	NM ¹	-0.459	1.770	0.069		
Back Face	45	CH 26365 (1882.5 MHz)	0.007	NM ¹	0.000 ³	1.770	0.012		
Left Edge	15	CH 26365 (1882.5 MHz)	0.007	NM ¹	-1.599	1.770	0.012		
Right Edge	15	CH 26365 (1882.5 MHz)	0.013	NM ¹	-4.391	1.770	0.023		
Top Edge	15	CH 26365 (1882.5 MHz)	0.150	0.156	-0.345	1.770	0.276		
Bottom Edge	15	CH 26365 (1882.5 MHz)	NM ²						
Top Edge	15	CH 26140 (1860.0 MHz)	0.162	0.170	1.042	1.845	0.314	5	
Top Edge	15	CH 26590 (1905.0 MHz)	0.133	0.132	-0.115	1.828	0.241		

1, 2 and 3: See remarks and comments

- Body measurements

Position	Dist (mm)	Channel (Frequency)	Estimated SAR 1-g (W/kg)	SAR 1-g (W/kg)	Power Drift (%)	Scale factor	Reported SAR 1-g (W/kg)	Plot No.	
Front Face	15	CH 26365 (1882.5 MHz)	0.043	NM ¹	-1.825	1.770	0.076		
Back Face	45	CH 26365 (1882.5 MHz)	0.007	NM ¹	0.000 ³	1.770	0.012		
Left Edge	15	CH 26365 (1882.5 MHz)	0.008	NM ¹	0.000 ³	1.770	0.014		
Right Edge	15	CH 26365 (1882.5 MHz)	0.018	NM ¹	2.329	1.770	0.032		
Top Edge	15	CH 26365 (1882.5 MHz)	0.169	0.171	-0.688	1.770	0.303		
Bottom Edge	15	CH 26365 (1882.5 MHz)	NM ²						
Top Edge	15	CH 26140 (1860.0 MHz)	0.185	0.189	-1.145	1.845	0.349	6	
Top Edge	15	CH 26590 (1905.0 MHz)	0.143	0.149	0.809	1.828	0.272		

1, 2 and 3: See remarks and comments

5.8. Results for LTE CAT M1 Band 25 (50% Rb, 20 MHz, QPSK).

- Head measurements

Position	Dist (mm)	Channel (Frequency)	Estimated SAR 1-g (W/kg)	SAR 1-g (W/kg)	Power Drift (%)	Scale factor	Reported SAR 1-g (W/kg)	Plot No.
Top Edge	15	CH 26365 (1882.5 MHz)	0.144	0.149	-1.031	1.871	0.279	

- Body measurements

Position	Dist (mm)	Channel (Frequency)	Estimated SAR 1-g (W/kg)	SAR 1-g (W/kg)	Power Drift (%)	Scale factor	Reported SAR 1-g (W/kg)	Plot No.
Top Edge	15	CH 26365 (1882.5 MHz)	0.158	0.166	0.115	1.871	0.311	

5.9. Results for LTE CAT M1 Band 26 (1 Rb, 15 MHz, QPSK).

- **Head measurements**

Position	Dist (mm)	Channel (Frequency)	Estimated SAR 1-g (W/kg)	SAR 1-g (W/kg)	Power Drift (%)	Scale factor	Reported SAR 1-g (W/kg)	Plot No.	
Front Face	15	CH 26865 (831.5 MHz)	0.008	NM ¹	-0.459	1.578	0.013		
Back Face	45	CH 26865 (831.5 MHz)	0.014	NM ¹	-2.051	1.578	0.022		
Left Edge	15	CH 26865 (831.5 MHz)	0.003	NM ¹	-1.258	1.578	0.005		
Right Edge	15	CH 26865 (831.5 MHz)	0.000 ³	NM ¹	0.000 ³	1.578	0.000 ³		
Top Edge	15	CH 26865 (831.5 MHz)	0.070	0.074	0.346	1.578	0.117		
Bottom Edge	15	CH 26865 (831.5 MHz)	NM ²						

1, 2 and 3: See remarks and comments

- **Body measurements**

Position	Dist (mm)	Channel (Frequency)	Estimated SAR 1-g (W/kg)	SAR 1-g (W/kg)	Power Drift (%)	Scale factor	Reported SAR 1-g (W/kg)	Plot No.	
Front Face	15	CH 26865 (831.5 MHz)	0.012	NM ¹	0.000 ³	1.578	0.019		
Back Face	45	CH 26865 (831.5 MHz)	0.012	NM ¹	-1.712	1.578	0.019		
Left Edge	15	CH 26865 (831.5 MHz)	0.005	NM ¹	0.000 ³	1.578	0.008		
Right Edge	15	CH 26865 (831.5 MHz)	0.002	NM ¹	0.000 ³	1.578	0.003		
Top Edge	15	CH 26865 (831.5 MHz)	0.084	0.090	1.042	1.578	0.142	8	
Bottom Edge	15	CH 26865 (831.5 MHz)	NM ²						

1, 2 and 3: See remarks and comments

5.10. Results for LTE CAT M1 Band 26 (50% Rb, 15 MHz, QPSK).

- Head measurements

Position	Dist (mm)	Channel (Frequency)	Estimated SAR 1-g (W/kg)	SAR 1-g (W/kg)	Power Drift (%)	Scale factor	Reported SAR 1-g (W/kg)	Plot No.
Top Edge	15	CH 26865 (831.5 MHz)	0.069	0.072	-0.230	1.667	0.120	7

- Body measurements

Position	Dist (mm)	Channel (Frequency)	Estimated SAR 1-g (W/kg)	SAR 1-g (W/kg)	Power Drift (%)	Scale factor	Reported SAR 1-g (W/kg)	Plot No.
Top Edge	15	CH 26865 (831.5 MHz)	0.081	0.085	-0.230	1.667	0.142	

5.11. Results for LTE CAT M1 Band 66 (1 Rb, 20 MHz, QPSK).

- **Head measurements**

Position	Dist (mm)	Channel (Frequency)	Estimated SAR 1-g (W/kg)	SAR 1-g (W/kg)	Power Drift (%)	Scale factor	Reported SAR 1-g (W/kg)	Plot No.	
Front Face	15	CH 132322 (1745.0 MHz)	0.040	NM ¹	-2.725	1.849	0.074		
Back Face	45	CH 132322 (1745.0 MHz)	0.006	NM ¹	0.000 ³	1.849	0.011		
Left Edge	15	CH 132322 (1745.0 MHz)	0.004	NM ¹	-2.164	1.849	0.007		
Right Edge	15	CH 132322 (1745.0 MHz)	0.009	NM ¹	0.462	1.849	0.017		
Top Edge	15	CH 132322 (1745.0 MHz)	0.139	0.146	0.577	1.849	0.270		
Bottom Edge	15	CH 132322 (1745.0 MHz)	NM ²						
Top Edge	15	CH 132072 (1720.0 MHz)	0.098	0.097	-1.031	1.919	0.186		
Top Edge	15	CH 132575 (1770.0 MHz)	0.215	0.224	-0.230	1.936	0.434	9	

1, 2 and 3: See remarks and comments

- **Body measurements**

Position	Dist (mm)	Channel (Frequency)	Estimated SAR 1-g (W/kg)	SAR 1-g (W/kg)	Power Drift (%)	Scale factor	Reported SAR 1-g (W/kg)	Plot No.	
Front Face	15	CH 132322 (1745.0 MHz)	0.042	NM ¹	2.447	1.849	0.078		
Back Face	45	CH 132322 (1745.0 MHz)	0.005	NM ¹	0.000 ³	1.849	0.009		
Left Edge	15	CH 132322 (1745.0 MHz)	0.005	NM ¹	0.000 ³	1.849	0.009		
Right Edge	15	CH 132322 (1745.0 MHz)	0.010	NM ¹	0.000 ³	1.849	0.018		
Top Edge	15	CH 132322 (1745.0 MHz)	0.165	0.170	-0.917	1.849	0.314		
Bottom Edge	15	CH 132322 (1745.0 MHz)	NM ²						
Top Edge	15	CH 132072 (1720.0 MHz)	0.104	0.108	0.115	1.919	0.207		
Top Edge	15	CH 132575 (1770.0 MHz)	0.252	0.260	-0.803	1.936	0.503	10	

1, 2 and 3: See remarks and comments

5.12. Results for LTE CAT M1 Band 66 (50% Rb, 20 MHz, QPSK).

- Head measurements

Position	Dist (mm)	Channel (Frequency)	Estimated SAR 1-g (W/kg)	SAR 1-g (W/kg)	Power Drift (%)	Scale factor	Reported SAR 1-g (W/kg)	Plot No.
Top Edge	15	CH 132322 (1745.0 MHz)	0.133	0.141	0.000	1.963	0.277	

- Body measurements

Position	Dist (mm)	Channel (Frequency)	Estimated SAR 1-g (W/kg)	SAR 1-g (W/kg)	Power Drift (%)	Scale factor	Reported SAR 1-g (W/kg)	Plot No.
Top Edge	15	CH 132322 (1745.0 MHz)	0.152	0.158	-1.031	1.963	0.310	

5.13. Results for LTE CAT M1 Band 71 (1 Rb, 20 MHz, QPSK).

- **Head measurements**

Position	Dist (mm)	Channel (Frequency)	Estimated SAR 1-g (W/kg)	SAR 1-g (W/kg)	Power Drift (%)	Scale factor	Reported SAR 1-g (W/kg)	Plot No.	
Front Face	15	CH 133222 (673.0 MHz)	0.005	NM ¹	0.115	1.633	0.008		
Back Face	45	CH 133222 (673.0 MHz)	0.010	NM ¹	1.976	1.633	0.016		
Left Edge	15	CH 133222 (673.0 MHz)	0.001	NM ¹	0.693	1.633	0.002		
Right Edge	15	CH 133222 (673.0 MHz)	0.001	NM ¹	0.000 ³	1.633	0.002		
Top Edge	15	CH 133222 (673.0 MHz)	0.072	0.075	1.042	1.633	0.122		
Bottom Edge	15	CH 133222 (673.0 MHz)	NM ²						
Top Edge	15	CH 133297 (680.5 MHz)	0.080	0.083	0.693	1.671	0.139		
Top Edge	15	CH 133471 (688.0 MHz)	0.088	0.089	0.000	1.683	0.150	11	

1, 2 and 3: See remarks and comments

- **Body measurements**

Position	Dist (mm)	Channel (Frequency)	Estimated SAR 1-g (W/kg)	SAR 1-g (W/kg)	Power Drift (%)	Scale factor	Reported SAR 1-g (W/kg)	Plot No.	
Front Face	15	CH 133222 (673.0 MHz)	0.008	NM ¹	0.115	1.633	0.013		
Back Face	45	CH 133222 (673.0 MHz)	0.011	NM ¹	0.000 ³	1.633	0.018		
Left Edge	15	CH 133222 (673.0 MHz)	0.000 ³	NM ¹	-3.506	1.633	0.000 ³		
Right Edge	15	CH 133222 (673.0 MHz)	0.000 ³	NM ¹	0.000 ³	1.633	0.000 ³		
Top Edge	15	CH 133222 (673.0 MHz)	0.083	0.087	1.742	1.633	0.142		
Bottom Edge	15	CH 133222 (673.0 MHz)	NM ²						
Top Edge	15	CH 133297 (680.5 MHz)	0.095	0.098	-0.345	1.671	0.164		
Top Edge	15	CH 133471 (688.0 MHz)	0.104	0.111	0.462	1.683	0.187	12	

1, 2 and 3: See remarks and comments

5.14. Results for LTE CAT M1 Band 71 (50% Rb, 20 MHz, QPSK).

- **Head measurements**

Position	Dist (mm)	Channel (Frequency)	Estimated SAR 1-g (W/kg)	SAR 1-g (W/kg)	Power Drift (%)	Scale factor	Reported SAR 1-g (W/kg)	Plot No.
Top Edge	15	CH 133222 (673.0 MHz)	0.084	0.086	0.462	1.698	0.146	

- **Body measurements**

Position	Dist (mm)	Channel (Frequency)	Estimated SAR 1-g (W/kg)	SAR 1-g (W/kg)	Power Drift (%)	Scale factor	Reported SAR 1-g (W/kg)	Plot No.
Top Edge	15	CH 133222 (673.0 MHz)	0.080	0.086	-0.459	1.698	0.146	

Appendix C: Measurement report

Plot N°1

Test Laboratory: DEKRA Testing and Certification, S.A.U; Date: 29/11/2022

DUT: RESMED; Type: Generic Device; Serial: 22222172415

Communication System: UID 10154 - CAG, LTE-FDD (SC-FDMA, 50% RB, 10 MHz, QPSK); Frequency: 707.5 MHz; Duty Cycle: 1:3.76184

Medium parameters used (interpolated): $f = 707.5$ MHz; $\sigma = 0.88$ S/m; $\epsilon_r = 43.27$; $\rho = 1000$ kg/m³

Phantom section: Flat Section

DASY5 Configuration:

- Probe: EX3DV4 - SN7766; ConvF(10.25, 10.25, 10.25) @ 707.5 MHz; Calibrated: 18/10/2022
- Sensor-Surface: 2mm (Mechanical Surface Detection (Locations From Previous Scan Used)), Sensor-Surface: 2mm (Mechanical Surface Detection)
- Electronics: DAE4 Sn1690; Calibrated: 13/10/2022
- Phantom: Flat Phantom ELI4.0; Type: QDOVA001BA; Serial: SN:1060
- Measurement SW: DASY52, Version 52.10 (4); SEMCAD X Version 14.6.14 (7483)

Flat Phantom/LTE 12, 50% RB Mid, Mid CH, Top Edge/Area Scan (111x181x1):

Interpolated grid: $dx=1.500$ mm, $dy=1.500$ mm

[Info: Interpolated medium parameters used for SAR evaluation.](#)

Maximum value of SAR (interpolated) = 0.144 W/kg

Flat Phantom/LTE 12, 50% RB Mid, Mid CH, Top Edge/Zoom Scan (5x5x7)/Cube 0:

Measurement grid: $dx=8$ mm, $dy=8$ mm, $dz=5$ mm

Reference Value = 11.57 V/m; Power Drift = -0.05 dB

Peak SAR (extrapolated) = 0.155 W/kg

SAR(1 g) = 0.125 W/kg; SAR(10 g) = 0.095 W/kg (SAR corrected for target medium)

Smallest distance from peaks to all points 3 dB below: Larger than measurement grid

Ratio of SAR at M2 to SAR at M1 = 78.7%

[Info: Interpolated medium parameters used for SAR evaluation.](#)

Maximum value of SAR (measured) = 0.140 W/kg

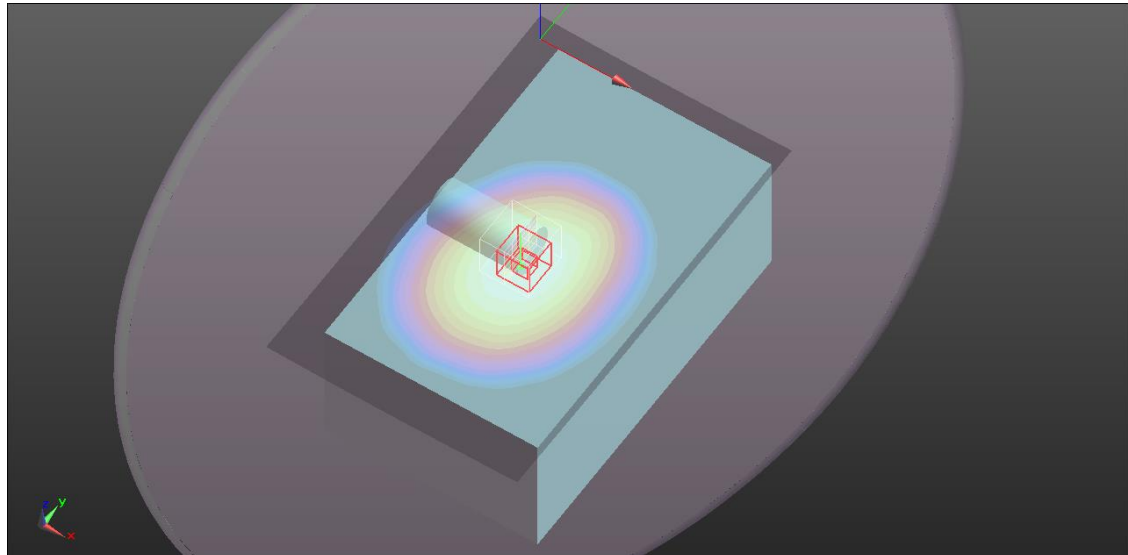
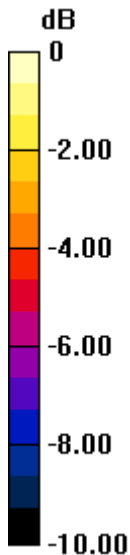

0 dB = 0.140 W/kg = -8.54 dBW/kg

Plot N°2

Test Laboratory: DEKRA Testing and Certification, S.A.U; Date: 28/11/2022

DUT: RESMED; Type: Generic Device; Serial: 22222172415

Communication System: UID 10154 - CAG, LTE-FDD (SC-FDMA, 50% RB, 10 MHz, QPSK); Frequency: 707.5 MHz; Duty Cycle: 1:3.76184

Medium parameters used (interpolated): $f = 707.5$ MHz; $\sigma = 0.945$ S/m; $\epsilon_r = 54.585$; $\rho = 1000$ kg/m³

Phantom section: Flat Section

DASY5 Configuration:

- Probe: EX3DV4 - SN7766; ConvF(10.38, 10.38, 10.38) @ 707.5 MHz; Calibrated: 18/10/2022
- Sensor-Surface: 2mm (Mechanical Surface Detection (Locations From Previous Scan Used)), Sensor-Surface: 2mm (Mechanical Surface Detection)
- Electronics: DAE4 Sn1690; Calibrated: 13/10/2022
- Phantom: Flat Phantom ELI4.0; Type: QDOVA001BA; Serial: SN:1060
- Measurement SW: DASY52, Version 52.10 (4); SEMCAD X Version 14.6.14 (7483)

Flat Phantom/LTE 12, 50% RB Mid, Mid CH, Top Edge/Area Scan (111x181x1):

Interpolated grid: $dx=1.500$ mm, $dy=1.500$ mm

[Info: Interpolated medium parameters used for SAR evaluation.](#)

Maximum value of SAR (interpolated) = 0.141 W/kg

Flat Phantom/LTE 12, 50% RB Mid, Mid CH, Top Edge/Zoom Scan (5x5x7)/Cube 0:

Measurement grid: $dx=8$ mm, $dy=8$ mm, $dz=5$ mm

Reference Value = 10.83 V/m; Power Drift = 0.01 dB

Peak SAR (extrapolated) = 0.157 W/kg

SAR(1 g) = 0.122 W/kg; SAR(10 g) = 0.094 W/kg (SAR corrected for target medium)

Smallest distance from peaks to all points 3 dB below: Larger than measurement grid

Ratio of SAR at M2 to SAR at M1 = 77.2%

[Info: Interpolated medium parameters used for SAR evaluation.](#)

Maximum value of SAR (measured) = 0.140 W/kg

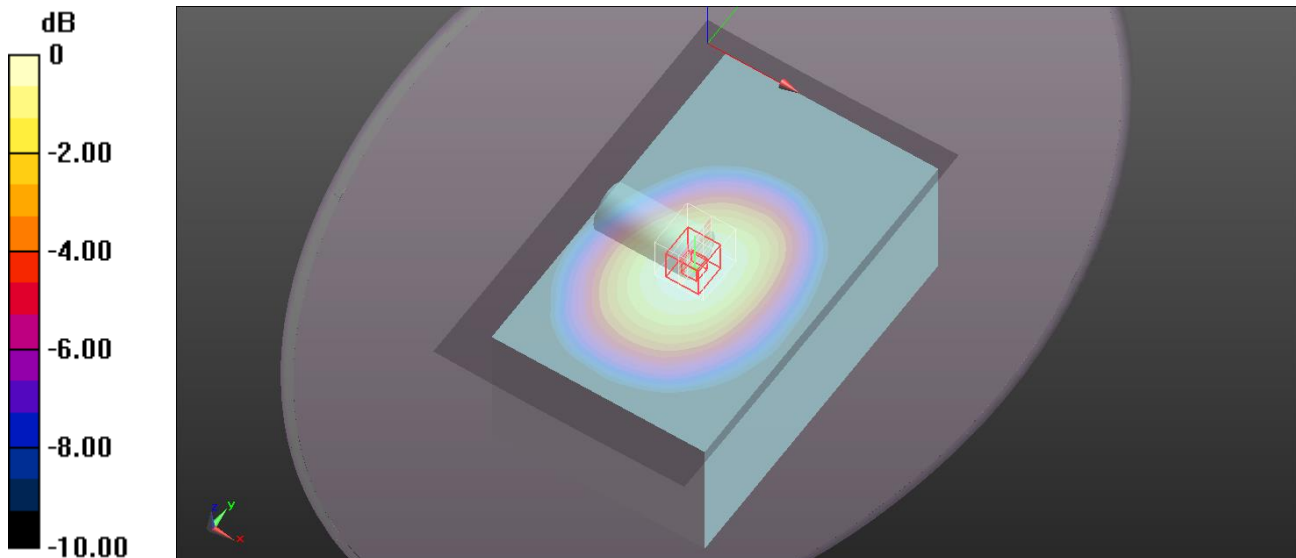

0 dB = 0.140 W/kg = -8.54 dBW/kg

Plot N°3

Model, Manufacturer	Dimensions [mm]	IMEI	DUT Type
RESMED,	230.0 x 90.0 x 140.0	354040470005107	CPAP Device

Exposure Conditions

Phantom Section, TSL	Position, Test Distance [mm]	Band	Group, UID	Frequency [MHz], Channel Number	Conversion Factor	TSL Conductivity [S/m]	TSL Permittivity
Flat, HSL	EDGE TOP, 15.00	Band 13, E- UTRA/FDD	LTE-FDD, 10154-CAG	782.0, 23230	10.07	0.910	42.0

Hardware Setup

Phantom	TSL, Measured Date	Probe, Calibration Date	DAE, Calibration Date
ELI V4.0 (20deg probe tilt) - 1060	HBBL 600-10000V6 -750MHz - 2022-10-25 , --	EX3DV4 - SN7461, 2022-08-25	DAE4 Sn1690, 2021-09-08

Scan Setup

	Area Scan	Zoom Scan
Grid Extents [mm]	180.0 x 300.0	30.0 x 30.0 x 30.0
Grid Steps [mm]	15.0 x 15.0	6.0 x 6.0 x 1.5
Sensor Surface [mm]	3.0	1.4
Graded Grid	Yes	Yes
Grading Ratio	1.5	1.5
MAIA	Y	N/A
Surface Detection	VMS + 6p	VMS + 6p
Scan Method	Measured	Measured

Measurement Results

	Area Scan	Zoom Scan
Date	2022-10-25, 17:46	2022-10-25, 17:52
psSAR1g [W/kg]	0.111	0.114
psSAR10g [W/kg]	0.079	0.085
Power Drift [dB]	0.00	0.02
Power Scaling	Disabled	Disabled
Scaling Factor [dB]		
TSL Correction	Positive only	Positive only
M2/M1 [%]		89.8
Dist 3dB Peak [mm]		> 15.0

Warning(s) / Error(s)

Details	Area Scan	Zoom Scan
Warning(s)		
Error(s)		

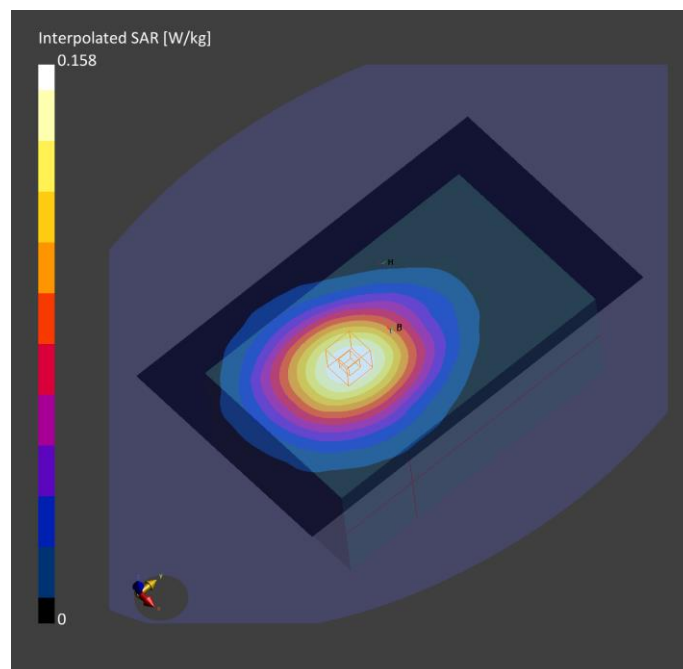

Plot N°4

Model, Manufacturer	Dimensions [mm]	IMEI	DUT Type
RESMED,	230.0 x 90.0 x 140.0	354040470005107	CPAP Device

Exposure Conditions

Phantom Section, TSL	Position, Test Distance [mm]	Band	Group, UID	Frequency [MHz], Channel Number	Conversion Factor	TSL Conductivity [S/m]	TSL Permittivity
Flat, MSL	EDGE TOP, 15.00	Band 13, E- UTRA/FDD	LTE-FDD, 10175-CAG	782.0, 23230	10.15	0.980	54.3

Hardware Setup

Phantom	TSL, Measured Date	Probe, Calibration Date	DAE, Calibration Date
ELI V4.0 (20deg probe tilt) - 1060	MSL750V2 - 2022-11-07 , --	EX3DV4 - SN7461, 2022-08-25	DAE4 Sn1690, 2021-09-08

Scan Setup

	Area Scan	Zoom Scan
Grid Extents [mm]	180.0 x 300.0	30.0 x 30.0 x 30.0
Grid Steps [mm]	15.0 x 15.0	6.0 x 6.0 x 1.5
Sensor Surface [mm]	3.0	1.4
Graded Grid	Yes	Yes
Grading Ratio	1.5	1.5
MAIA	Y	N/A
Surface Detection	VMS + 6p	VMS + 6p
Scan Method	Measured	Measured

Measurement Results

	Area Scan	Zoom Scan
Date	2022-11-07, 11:34	2022-11-07, 11:41
psSAR1g [W/kg]	0.119	0.123
psSAR10g [W/kg]	0.084	0.092
Power Drift [dB]	-0.04	-0.02
Power Scaling	Disabled	Disabled
Scaling Factor [dB]		
TSL Correction	Positive only	Positive only
M2/M1 [%]		87.9
Dist 3dB Peak [mm]		> 15.0

Warning(s) / Error(s)

Details	Area Scan	Zoom Scan
Warning(s)		
Error(s)		

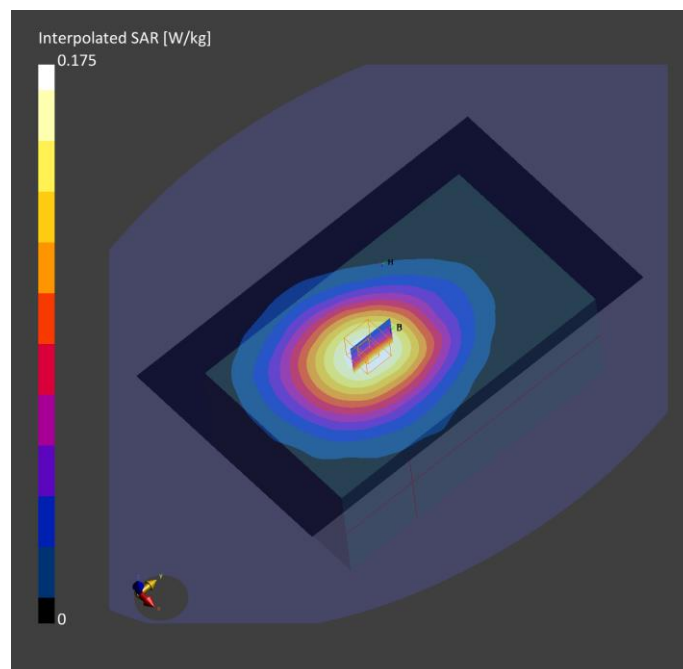

Plot N°5

Model, Manufacturer	Dimensions [mm]	IMEI	DUT Type
RESMED,	230.0 x 90.0 x 140.0	354040470005107	CPAP Device

Exposure Conditions

Phantom Section, TSL	Position, Test Distance [mm]	Band	Group, UID	Frequency [MHz], Channel Number	Conversion Factor	TSL Conductivity [S/m]	TSL Permittivity
Flat, HSL	EDGE TOP, 15.00	Band 25, E- UTRA/FDD	LTE-FDD, 10169-CAE	1860.0, 26140	8.3	1.40	39.9

Hardware Setup

Phantom	TSL, Measured Date	Probe, Calibration Date	DAE, Calibration Date
ELI V4.0 (20deg probe tilt) - 1060	HBBL 600-10000V6 - 1700-1920MHz - 2022-10-26 , --	EX3DV4 - SN7461, 2022-08-25	DAE4 Sn1690, 2021-09-08

Scan Setup

	Area Scan	Zoom Scan
Grid Extents [mm]	180.0 x 300.0	30.0 x 30.0 x 30.0
Grid Steps [mm]	15.0 x 15.0	6.0 x 6.0 x 1.5
Sensor Surface [mm]	3.0	1.4
Graded Grid	Yes	Yes
Grading Ratio	1.5	1.5
MAIA	Y	Y
Surface Detection	VMS + 6p	VMS + 6p
Scan Method	Measured	Measured

Measurement Results

	Area Scan	Zoom Scan
Date	2022-10-27, 07:49	2022-10-27, 07:56
psSAR1g [W/kg]	0.162	0.170
psSAR10g [W/kg]	0.093	0.10
Power Drift [dB]	0.07	0.07
Power Scaling	Disabled	Disabled
Scaling Factor [dB]		
TSL Correction	Positive only	Positive only
M2/M1 [%]		83.9
Dist 3dB Peak [mm]		14.0

Warning(s) / Error(s)

Details	Area Scan	Zoom Scan
Warning(s)		
Error(s)		

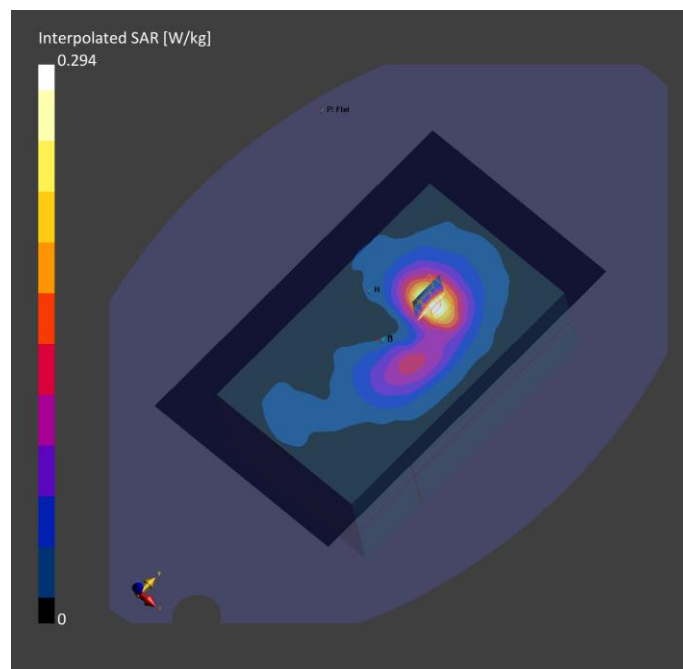

Plot N°6

Model, Manufacturer	Dimensions [mm]	IMEI	DUT Type
RESMED,	230.0 x 90.0 x 140.0	354040470005107	CPAP Device

Exposure Conditions

Phantom Section, TSL	Position, Test Distance [mm]	Band	Group, UID	Frequency [MHz], Channel Number	Conversion Factor	TSL Conductivity [S/m]	TSL Permittivity
Flat, MSL	EDGE TOP, 15.00	Band 25, E- UTRA/FDD	LTE-FDD, 10169-CAE	1860.0, 26140	8.28	1.54	52.9

Hardware Setup

Phantom	TSL, Measured Date	Probe, Calibration Date	DAE, Calibration Date
ELI V4.0 (20deg probe tilt) - 1060	MBBL1550-1950V3-2022-11-09 , --	EX3DV4 - SN7461, 2022-08-25	DAE4 Sn1690, 2021-09-08

Scan Setup

	Area Scan	Zoom Scan
Grid Extents [mm]	180.0 x 300.0	30.0 x 30.0 x 30.0
Grid Steps [mm]	15.0 x 15.0	6.0 x 6.0 x 1.5
Sensor Surface [mm]	3.0	1.4
Graded Grid	Yes	Yes
Grading Ratio	1.5	1.5
MAIA	Y	Y
Surface Detection	VMS + 6p	VMS + 6p
Scan Method	Measured	Measured

Measurement Results

	Area Scan	Zoom Scan
Date	2022-11-09, 12:55	2022-11-09, 13:01
psSAR1g [W/kg]	0.185	0.189
psSAR10g [W/kg]	0.103	0.110
Power Drift [dB]	0.01	-0.02
Power Scaling	Disabled	Disabled
Scaling Factor [dB]		
TSL Correction	Positive only	Positive only
M2/M1 [%]		84.4
Dist 3dB Peak [mm]		13.2

Warning(s) / Error(s)

Details	Area Scan	Zoom Scan
Warning(s)		
Error(s)		

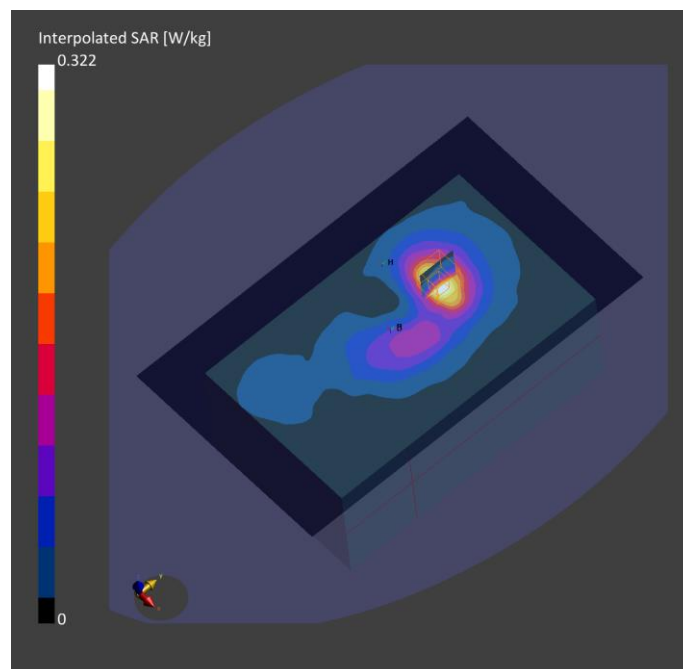

Plot N°7

Model, Manufacturer	Dimensions [mm]	IMEI	DUT Type
RESMED,	230.0 x 90.0 x 140.0	354040470005107	CPAP Device

Exposure Conditions

Phantom Section, TSL	Position, Test Distance [mm]	Band	Group, UID	Frequency [MHz], Channel Number	Conversion Factor	TSL Conductivity [S/m]	TSL Permittivity
Flat, HSL	EDGE TOP, 15.00	Band 26 E- UTRA/FDD	LTE-FDD, 10160-CAE	831.5, 26865	9.61	0.930	41.8

Hardware Setup

Phantom	TSL, Measured Date	Probe, Calibration Date	DAE, Calibration Date
ELI V4.0 (20deg probe tilt) - 1060	HBBL 600-10000V6 - 900MHz- 2022-10-26 , --	EX3DV4 - SN7461, 2022-08-25	DAE4 Sn1690, 2021-09-08

Scan Setup

	Area Scan	Zoom Scan
Grid Extents [mm]	180.0 x 300.0	30.0 x 30.0 x 30.0
Grid Steps [mm]	15.0 x 15.0	6.0 x 6.0 x 1.5
Sensor Surface [mm]	3.0	1.4
Graded Grid	Yes	Yes
Grading Ratio	1.5	1.5
MAIA	Y	Y
Surface Detection	VMS + 6p	VMS + 6p
Scan Method	Measured	Measured

Measurement Results

	Area Scan	Zoom Scan
Date	2022-10-26, 21:34	2022-10-26, 21:40
psSAR1g [W/kg]	0.069	0.072
psSAR10g [W/kg]	0.049	0.054
Power Drift [dB]	0.01	-0.00
Power Scaling	Disabled	Disabled
Scaling Factor [dB]		
TSL Correction	Positive only	Positive only
M2/M1 [%]		92.2
Dist 3dB Peak [mm]		> 15.0

Warning(s) / Error(s)

Details	Area Scan	Zoom Scan
Warning(s)		
Error(s)		

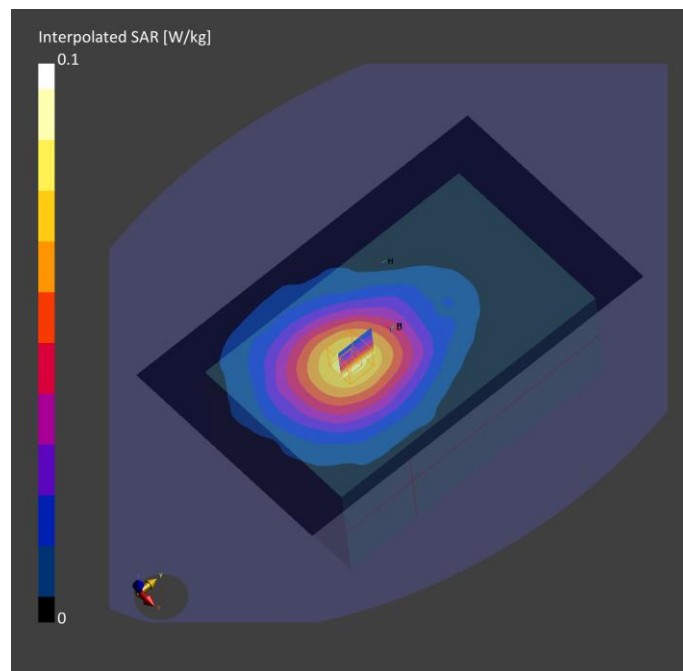

Plot N°8

Model, Manufacturer	Dimensions [mm]	IMEI	DUT Type
RESMED,	230.0 x 90.0 x 140.0	354040470005107	CPAP Device

Exposure Conditions

Phantom Section, TSL	Position, Test Distance [mm]	Band	Group, UID	Frequency [MHz], Channel Number	Conversion Factor	TSL Conductivity [S/m]	TSL Permittivity
Flat, MSL	EDGE TOP, 15.00	Band 26 E- UTRA/FDD	LTE-FDD, 10181-CAE	831.5, 26865	9.75	0.963	54.3

Hardware Setup

Phantom	TSL, Measured Date	Probe, Calibration Date	DAE, Calibration Date
ELI V4.0 (20deg probe tilt) - 1060	MSL900V2-2022-09-29 , --	EX3DV4 - SN7461, 2022-08-25	DAE4 Sn1690, 2021-09-08

Scan Setup

	Area Scan	Zoom Scan
Grid Extents [mm]	180.0 x 300.0	30.0 x 30.0 x 30.0
Grid Steps [mm]	15.0 x 15.0	6.0 x 6.0 x 1.5
Sensor Surface [mm]	3.0	1.4
Graded Grid	Yes	Yes
Grading Ratio	1.5	1.5
MAIA	Y	Y
Surface Detection	VMS + 6p	VMS + 6p
Scan Method	Measured	Measured

Measurement Results

	Area Scan	Zoom Scan
Date	2022-11-08, 14:17	2022-11-08, 14:23
psSAR1g [W/kg]	0.084	0.090
psSAR10g [W/kg]	0.059	0.070
Power Drift [dB]	0.11	-0.15
Power Scaling	Disabled	Disabled
Scaling Factor [dB]		
TSL Correction	Positive only	Positive only
M2/M1 [%]		91.1
Dist 3dB Peak [mm]		> 15.0

Warning(s) / Error(s)

Details	Area Scan	Zoom Scan
Warning(s)		
Error(s)		

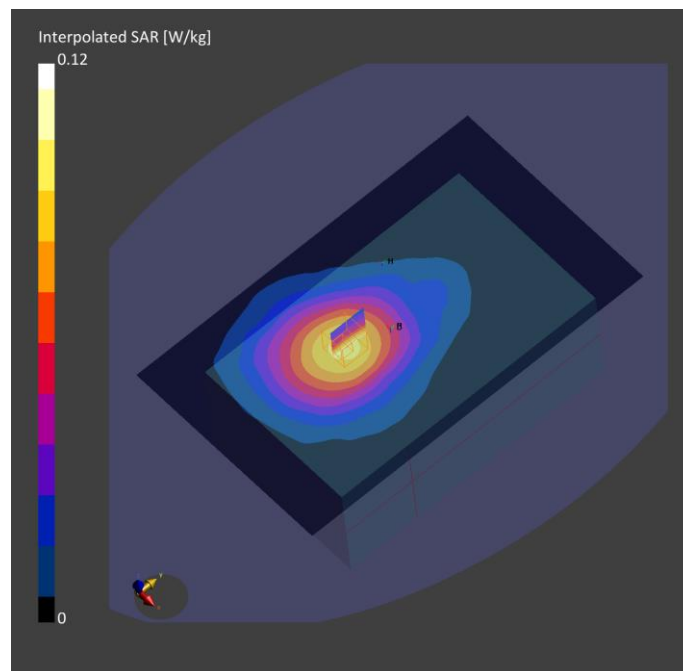

Plot N°9

Model, Manufacturer	Dimensions [mm]	IMEI	DUT Type
RESMED,	230.0 x 90.0 x 140.0	354040470005107	CPAP Device

Exposure Conditions

Phantom Section, TSL	Position, Test Distance [mm]	Band	Group, UID	Frequency [MHz], Channel Number	Conversion Factor	TSL Conductivity [S/m]	TSL Permittivity
Flat, HSL	EDGE TOP, 15.00	Band 66, E- UTRA/FDD	LTE-FDD, 10169-CAE	1770.0, 132572	8.3	1.35	40.1

Hardware Setup

Phantom	TSL, Measured Date	Probe, Calibration Date	DAE, Calibration Date
ELI V4.0 (20deg probe tilt) - 1060	HBBL 600-10000V6 - 1700-1920MHz - 2022-10-26 , --	EX3DV4 - SN7461, 2022-08-25	DAE4 Sn1690, 2021-09-08

Scan Setup

	Area Scan	Zoom Scan
Grid Extents [mm]	180.0 x 300.0	30.0 x 30.0 x 30.0
Grid Steps [mm]	15.0 x 15.0	6.0 x 6.0 x 1.5
Sensor Surface [mm]	3.0	1.4
Graded Grid	Yes	Yes
Grading Ratio	1.5	1.5
MAIA	Y	Y
Surface Detection	VMS + 6p	VMS + 6p
Scan Method	Measured	Measured

Measurement Results

	Area Scan	Zoom Scan
Date	2022-10-27, 09:40	2022-10-27, 09:46
psSAR1g [W/kg]	0.215	0.224
psSAR10g [W/kg]	0.123	0.133
Power Drift [dB]	-0.02	-0.00
Power Scaling	Disabled	Disabled
Scaling Factor [dB]		
TSL Correction	Positive only	Positive only
M2/M1 [%]		84.8
Dist 3dB Peak [mm]		12.9

Warning(s) / Error(s)

Details	Area Scan	Zoom Scan
Warning(s)		
Error(s)		

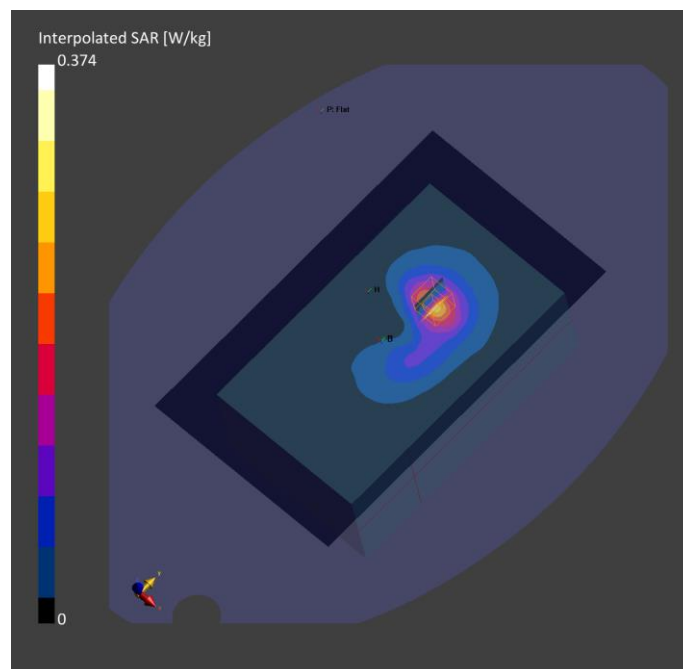

Plot N°10

Model, Manufacturer	Dimensions [mm]	IMEI	DUT Type
RESMED,	230.0 x 90.0 x 140.0	354040470005107	CPAP Device

Exposure Conditions

Phantom Section, TSL	Position, Test Distance [mm]	Band	Group, UID	Frequency [MHz], Channel Number	Conversion Factor	TSL Conductivity [S/m]	TSL Permittivity
Flat, MSL	EDGE TOP, 15.00	Band 66, E- UTRA/FDD	LTE-FDD, 10169-CAE	1770.0, 132572	8.28	1.50	53.3

Hardware Setup

Phantom	TSL, Measured Date	Probe, Calibration Date	DAE, Calibration Date
ELI V4.0 (20deg probe tilt) - 1060	MBBL1550-1950V3-2022-11-09 , --	EX3DV4 - SN7461, 2022-08-25	DAE4 Sn1690, 2021-09-08

Scan Setup

	Area Scan	Zoom Scan
Grid Extents [mm]	180.0 x 300.0	30.0 x 30.0 x 30.0
Grid Steps [mm]	15.0 x 15.0	6.0 x 6.0 x 1.5
Sensor Surface [mm]	3.0	1.4
Graded Grid	Yes	Yes
Grading Ratio	1.5	1.5
MAIA	Y	Y
Surface Detection	VMS + 6p	VMS + 6p
Scan Method	Measured	Measured

Measurement Results

	Area Scan	Zoom Scan
Date	2022-11-10, 08:50	2022-11-10, 08:56
psSAR1g [W/kg]	0.252	0.260
psSAR10g [W/kg]	0.141	0.152
Power Drift [dB]	-0.08	-0.00
Power Scaling	Disabled	Disabled
Scaling Factor [dB]		
TSL Correction	Positive only	Positive only
M2/M1 [%]		85.6
Dist 3dB Peak [mm]		12.5

Warning(s) / Error(s)

Details	Area Scan	Zoom Scan
Warning(s)		
Error(s)		

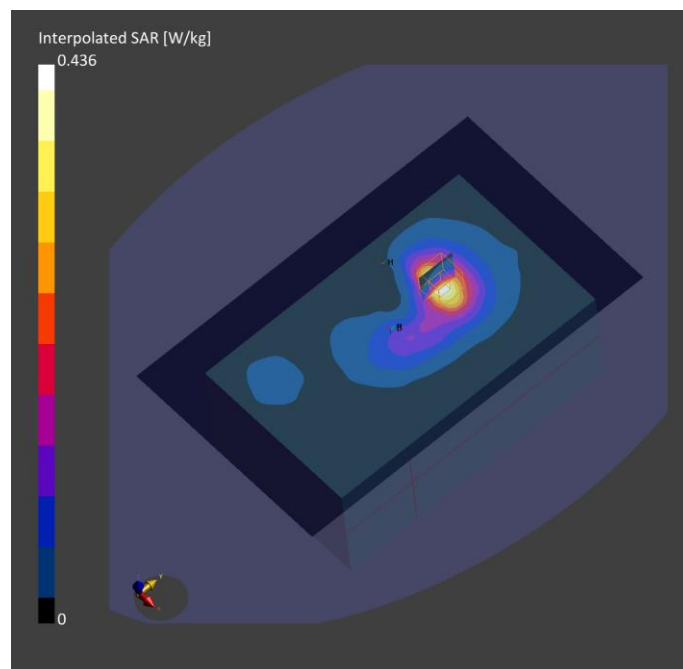

Plot N°11

Model, Manufacturer	Dimensions [mm]	IMEI	DUT Type
RESMED,	230.0 x 90.0 x 140.0	354040470005107	CPAP Device

Exposure Conditions

Phantom Section, TSL	Position, Test Distance [mm]	Band	Group, UID	Frequency [MHz], Channel Number	Conversion Factor	TSL Conductivity [S/m]	TSL Permittivity
Flat, HSL	EDGE TOP, 15.00	Band 71, E- UTRA/FDD	LTE-FDD, 10169-CAE	688.0, 133372	10.07	0.880	42.3

Hardware Setup

Phantom	TSL, Measured Date	Probe, Calibration Date	DAE, Calibration Date
ELI V4.0 (20deg probe tilt) - 1060	HBBL 600-10000V6 -750MHz - 2022-10-25 , --	EX3DV4 - SN7461, 2022-08-25	DAE4 Sn1690, 2021-09-08

Scan Setup

	Area Scan	Zoom Scan
Grid Extents [mm]	180.0 x 300.0	30.0 x 30.0 x 30.0
Grid Steps [mm]	15.0 x 15.0	6.0 x 6.0 x 1.5
Sensor Surface [mm]	3.0	1.4
Graded Grid	Yes	Yes
Grading Ratio	1.5	1.5
MAIA	Y	Y
Surface Detection	VMS + 6p	VMS + 6p
Scan Method	Measured	Measured

Measurement Results

	Area Scan	Zoom Scan
Date	2022-10-25, 14:45	2022-10-25, 14:52
psSAR1g [W/kg]	0.088	0.089
psSAR10g [W/kg]	0.063	0.067
Power Drift [dB]	0.01	0.02
Power Scaling	Disabled	Disabled
Scaling Factor [dB]		
TSL Correction	Positive only	Positive only
M2/M1 [%]		89.2
Dist 3dB Peak [mm]		> 15.0

Warning(s) / Error(s)

Details	Area Scan	Zoom Scan
Warning(s)		
Error(s)		

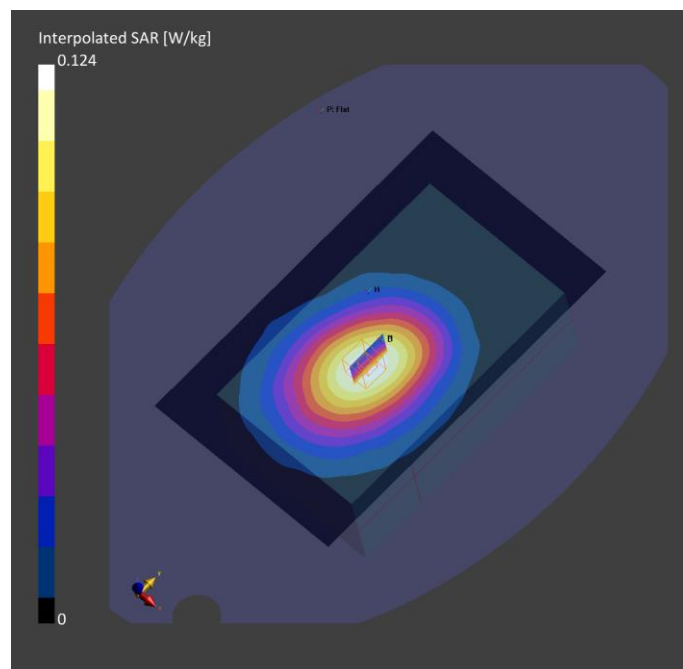

Plot N°12

Model, Manufacturer	Dimensions [mm]	IMEI	DUT Type
RESMED,	230.0 x 90.0 x 140.0	354040470005107	CPAP Device

Exposure Conditions

Phantom Section, TSL	Position, Test Distance [mm]	Band	Group, UID	Frequency [MHz], Channel Number	Conversion Factor	TSL Conductivity [S/m]	TSL Permittivity
Flat, MSL	EDGE TOP, 15.00	Band 71, E- UTRA/FDD	LTE-FDD, 10169-CAE	688.0, 133372	10.15	0.939	55.5

Hardware Setup

Phantom	TSL, Measured Date	Probe, Calibration Date	DAE, Calibration Date
ELI V4.0 (20deg probe tilt) - 1060	MSL750V2 - 2022-11-07 , --	EX3DV4 - SN7461, 2022-08-25	DAE4 Sn1690, 2021-09-08

Scan Setup

	Area Scan	Zoom Scan
Grid Extents [mm]	180.0 x 300.0	30.0 x 30.0 x 30.0
Grid Steps [mm]	15.0 x 15.0	6.0 x 6.0 x 1.5
Sensor Surface [mm]	3.0	1.4
Graded Grid	Yes	Yes
Grading Ratio	1.5	1.5
MAIA	Y	N/A
Surface Detection	VMS + 6p	VMS + 6p
Scan Method	Measured	Measured

Measurement Results

	Area Scan	Zoom Scan
Date	2022-11-07, 10:38	2022-11-07, 10:44
psSAR1g [W/kg]	0.104	0.111
psSAR10g [W/kg]	0.074	0.085
Power Drift [dB]	0.01	0.02
Power Scaling	Disabled	Disabled
Scaling Factor [dB]		
TSL Correction	Positive only	Positive only
M2/M1 [%]		89.8
Dist 3dB Peak [mm]		> 15.0

Warning(s) / Error(s)

Details	Area Scan	Zoom Scan
Warning(s)		
Error(s)		

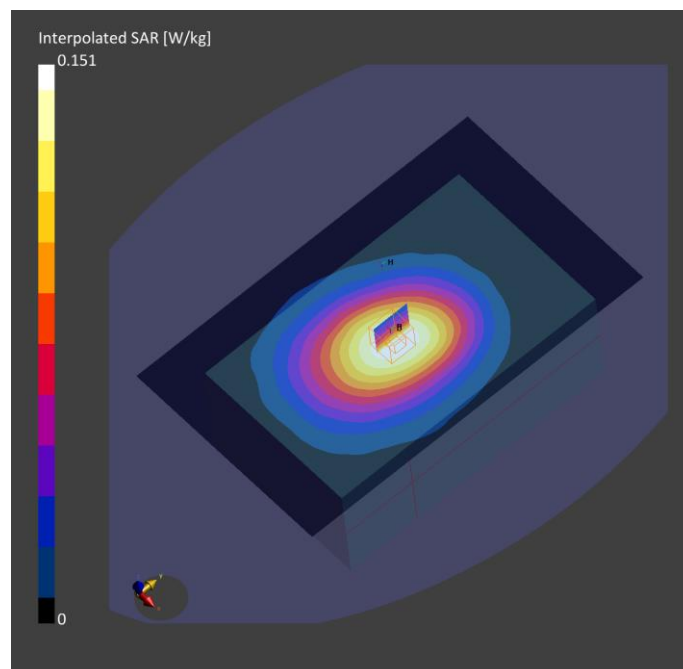

Appendix D: System Validation Report

Validation results in 750 MHz Band for Head TSL

Model, Manufacturer	Dimensions [mm]	IMEI	DUT Type
Device,	50.0 x 10.0 x 8.0		Dipole

Exposure Conditions

Phantom Section, TSL	Position, Test Distance [mm]	Band	Group, UID	Frequency [MHz], Channel Number	Conversion Factor	TSL Conductivity [S/m]	TSL Permittivity
Flat, HSL	,		, 0--	750.0, 0	10.07	0.900	42.1

Hardware Setup

Phantom	TSL, Measured Date	Probe, Calibration Date	DAE, Calibration Date
ELI V4.0 (20deg probe tilt) - 1060	HBBL 600-10000V6 -750MHz - 2022-10-25 , --	EX3DV4 - SN7461, 2022-08-25	DAE4 Sn1690, 2021-09-08

Scan Setup

	Area Scan	Zoom Scan
Grid Extents [mm]	40.0 x 90.0	30.0 x 30.0 x 30.0
Grid Steps [mm]	10.0 x 15.0	6.0 x 6.0 x 1.5
Sensor Surface [mm]	3.0	1.4
Graded Grid	Yes	Yes
Grading Ratio	1.5	1.5
MAIA	N/A	N/A
Surface Detection	VMS + 6p	VMS + 6p
Scan Method	Measured	Measured

Measurement Results

	Area Scan	Zoom Scan
Date	2022-10-25, 09:45	2022-10-25, 09:50
psSAR1g [W/kg]	2.24	2.18
psSAR10g [W/kg]	1.49	1.42
Power Drift [dB]	-0.00	-0.01
Power Scaling	Disabled	Disabled
Scaling Factor [dB]		
TSL Correction	Positive only	Positive only
M2/M1 [%]		86.8
Dist 3dB Peak [mm]		19.7

Warning(s) / Error(s)

Details	Area Scan	Zoom Scan
Warning(s)		
Error(s)		

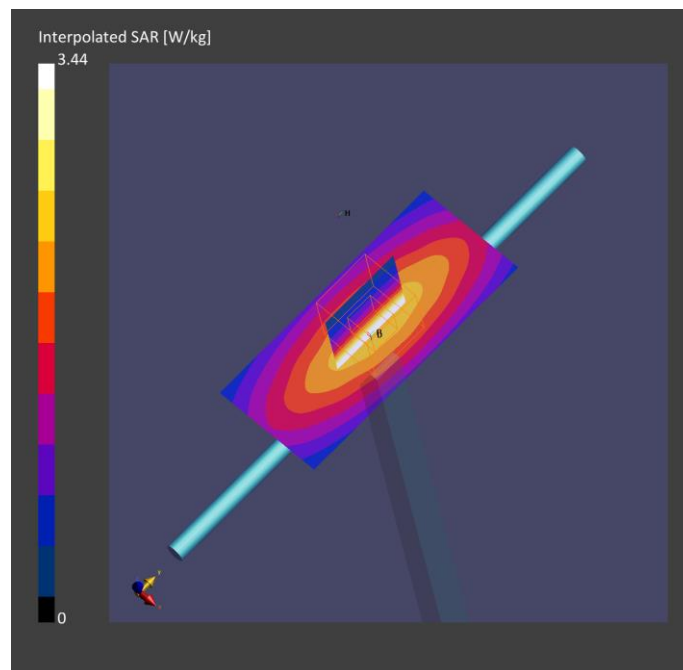

Validation results in 750 MHz Band for Body TSL

Model, Manufacturer	Dimensions [mm]	IMEI	DUT Type
Device,	50.0 x 10.0 x 8.0		Dipole

Exposure Conditions

Phantom Section, TSL	Position, Test Distance [mm]	Band	Group, UID	Frequency [MHz], Channel Number	Conversion Factor	TSL Conductivity [S/m]	TSL Permittivity
Flat, MSL	,		CW, 0--	750.0, 0	10.15	0.970	54.7

Hardware Setup

Phantom	TSL, Measured Date	Probe, Calibration Date	DAE, Calibration Date
ELI V4.0 (20deg probe tilt) - 1060	MSL750V2 - 2022-11-07 , --	EX3DV4 - SN7461, 2022-08-25	DAE4 Sn1690, 2021-09-08

Scan Setup

	Area Scan	Zoom Scan
Grid Extents [mm]	40.0 x 90.0	30.0 x 30.0 x 30.0
Grid Steps [mm]	10.0 x 15.0	6.0 x 6.0 x 1.5
Sensor Surface [mm]	3.0	1.4
Graded Grid	Yes	Yes
Grading Ratio	1.5	1.5
MAIA	N/A	N/A
Surface Detection	VMS + 6p	VMS + 6p
Scan Method	Measured	Measured

Measurement Results

	Area Scan	Zoom Scan
Date	2022-11-07, 08:26	2022-11-07, 08:31
psSAR1g [W/kg]	2.29	2.27
psSAR10g [W/kg]	1.52	1.50
Power Drift [dB]	-0.00	0.01
Power Scaling	Disabled	Disabled
Scaling Factor [dB]		
TSL Correction	Positive only	Positive only
M2/M1 [%]		85.6
Dist 3dB Peak [mm]		18.3

Warning(s) / Error(s)

Details	Area Scan	Zoom Scan
Warning(s)		
Error(s)		

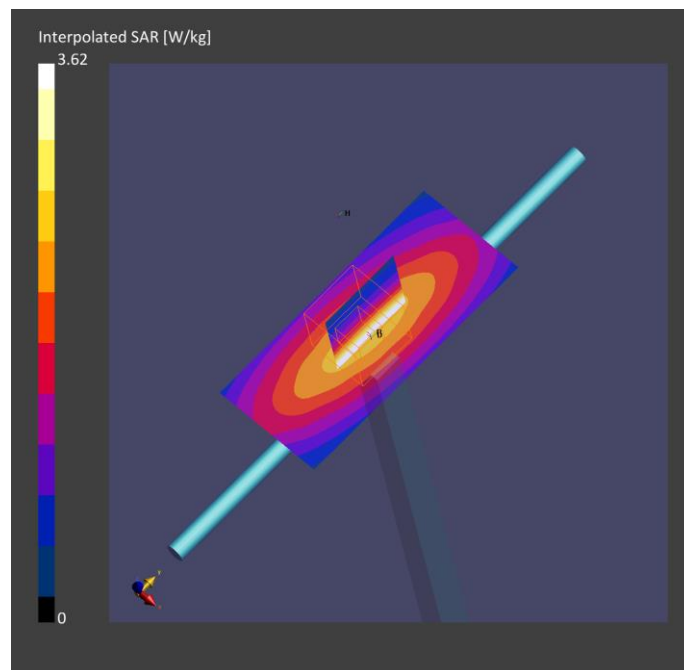

Validation results in 750 MHz Band for Head TSL

Test Laboratory: DEKRA Testing and Certification, S.A.U; Date: 29/11/2022

DUT: Dipole 750 MHz D750V3; Type: D750V3; Serial: D750V3 - SN:1036

Communication System: UID 0, CW (0); Frequency: 750 MHz; Duty Cycle: 1:1

Medium parameters used: $f = 750$ MHz; $\sigma = 0.91$ S/m; $\epsilon_r = 42.68$; $\rho = 1000$ kg/m³

Phantom section: Flat Section

DASY5 Configuration:

- Probe: EX3DV4 - SN7766; ConvF(10.25, 10.25, 10.25) @ 750 MHz; Calibrated: 18/10/2022
- Sensor-Surface: 2mm (Mechanical Surface Detection)
- Electronics: DAE4 Sn1690; Calibrated: 13/10/2022
- Phantom: Flat Phantom ELI4.0; Type: QDOVA001BA; Serial: SN:1060
- Measurement SW: DASY52, Version 52.10 (4); SEMCAD X Version 14.6.14 (7483)

Configuration 750MHz, Head, 2022-11-29/d=15mm, Pin=250 mW/Area Scan (61x91x1):

Interpolated grid: $dx=1.500$ mm, $dy=1.500$ mm

Maximum value of SAR (interpolated) = 2.60 W/kg

Configuration 750MHz, Head, 2022-11-29/d=15mm, Pin=250 mW/Zoom Scan (7x7x7)/Cube 0:

Measurement grid: $dx=5$ mm, $dy=5$ mm, $dz=5$ mm

Reference Value = 54.20 V/m; Power Drift = 0.04 dB

Peak SAR (extrapolated) = 3.03 W/kg

SAR(1 g) = 2.06 W/kg; SAR(10 g) = 1.36 W/kg (SAR corrected for target medium)

Smallest distance from peaks to all points 3 dB below: Larger than measurement grid

Ratio of SAR at M2 to SAR at M1 = 67.8%

Maximum value of SAR (measured) = 2.59 W/kg

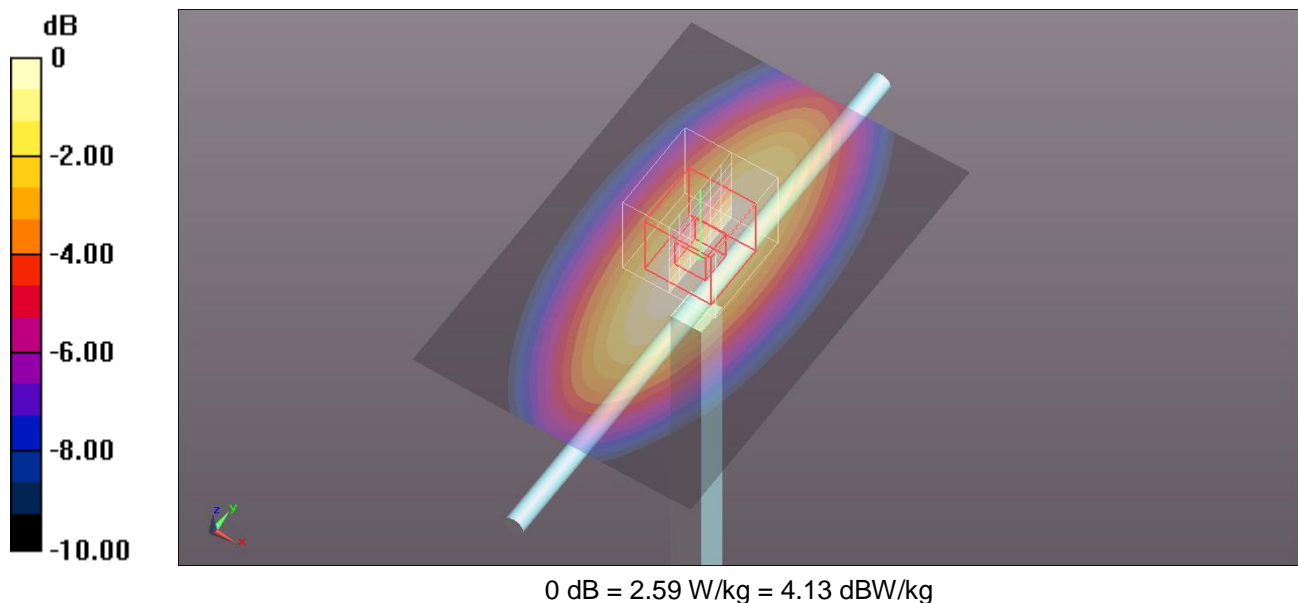

Validation results in 750 MHz Band for Body TSL

Test Laboratory: DEKRA Testing and Certification, S.A.U; Date: 28/11/2022

DUT: Dipole 750 MHz D750V3; Type: D750V3; Serial: D750V3 - SN:1036

Communication System: UID 0, CW (0); Frequency: 750 MHz; Duty Cycle: 1:1

Medium parameters used: $f = 750$ MHz; $\sigma = 0.97$ S/m; $\epsilon_r = 54.07$; $\rho = 1000$ kg/m³

Phantom section: Flat Section

DASY5 Configuration:

- Probe: EX3DV4 - SN7766; ConvF(10.38, 10.38, 10.38) @ 750 MHz; Calibrated: 18/10/2022
- Sensor-Surface: 2mm (Mechanical Surface Detection)
- Electronics: DAE4 Sn1690; Calibrated: 13/10/2022
- Phantom: Flat Phantom ELI4.0; Type: QDOVA001BA; Serial: SN:1060
- Measurement SW: DASY52, Version 52.10 (4); SEMCAD X Version 14.6.14 (7483)

Configuration 750MHz Body, 2022-11-28/d=15mm, Pin=250 mW/Area Scan (61x91x1):

Interpolated grid: $dx=1.500$ mm, $dy=1.500$ mm

Maximum value of SAR (interpolated) = 2.71 W/kg

Configuration 750MHz Body, 2022-11-28/d=15mm, Pin=250 mW/Zoom Scan (7x7x7)/Cube 0:

Measurement grid: $dx=5$ mm, $dy=5$ mm, $dz=5$ mm

Reference Value = 53.17 V/m; Power Drift = 0.08 dB

Peak SAR (extrapolated) = 3.28 W/kg

SAR(1 g) = 2.15 W/kg; SAR(10 g) = 1.42 W/kg (SAR corrected for target medium)

Smallest distance from peaks to all points 3 dB below = 19.5 mm

Ratio of SAR at M2 to SAR at M1 = 66.3%

Maximum value of SAR (measured) = 2.73 W/kg

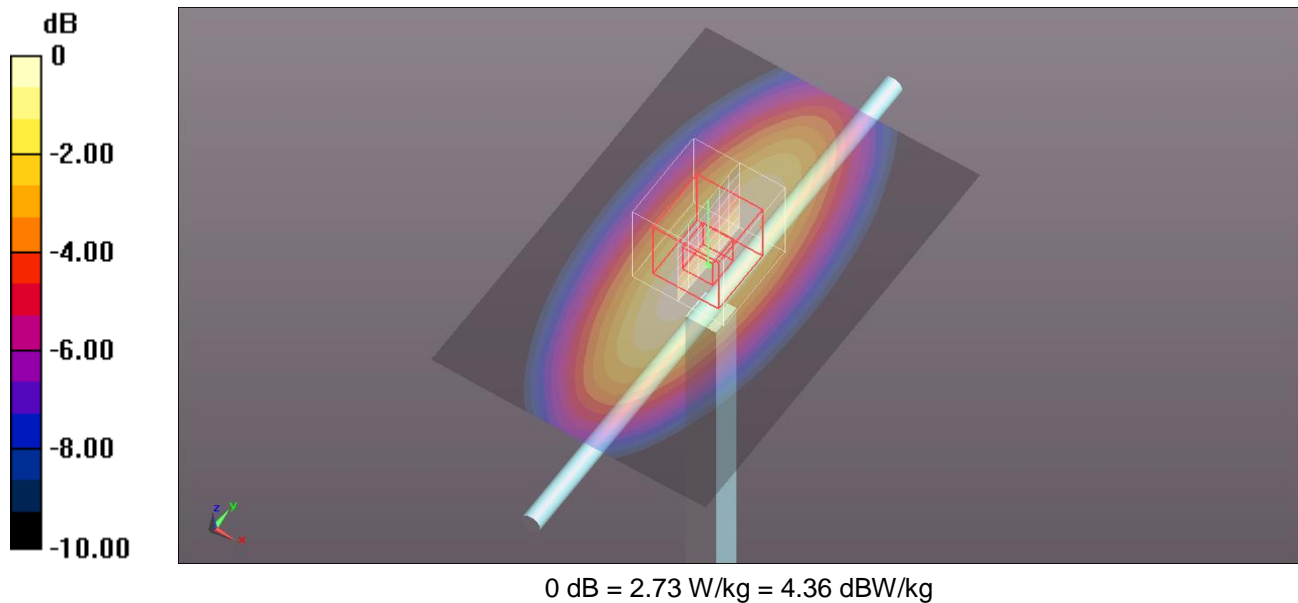

Validation results in 900 MHz Band for Head TSL

Model, Manufacturer	Dimensions [mm]	IMEI	DUT Type
Device,	50.0 x 10.0 x 8.0		Dipole

Exposure Conditions

Phantom Section, TSL	Position, Test Distance [mm]	Band	Group, UID	Frequency [MHz], Channel Number	Conversion Factor	TSL Conductivity [S/m]	TSL Permittivity
Flat, HSL	,		, 0--	900.0, 0	9.61	0.950	41.7

Hardware Setup

Phantom	TSL, Measured Date	Probe, Calibration Date	DAE, Calibration Date
ELI V4.0 (20deg probe tilt) - 1060	HBBL 600-10000V6 - 900MHz- 2022-10-26 , --	EX3DV4 - SN7461, 2022-08-25	DAE4 Sn1690, 2021-09-08

Scan Setup

	Area Scan	Zoom Scan
Grid Extents [mm]	40.0 x 90.0	30.0 x 30.0 x 30.0
Grid Steps [mm]	10.0 x 15.0	6.0 x 6.0 x 1.5
Sensor Surface [mm]	3.0	1.4
Graded Grid	Yes	Yes
Grading Ratio	1.5	1.5
MAIA	N/A	N/A
Surface Detection	VMS + 6p	VMS + 6p
Scan Method	Measured	Measured

Measurement Results

	Area Scan	Zoom Scan
Date	2022-10-26, 19:46	2022-10-26, 19:51
psSAR1g [W/kg]	2.82	2.77
psSAR10g [W/kg]	1.83	1.78
Power Drift [dB]	-0.04	-0.00
Power Scaling	Disabled	Disabled
Scaling Factor [dB]		
TSL Correction	Positive only	Positive only
M2/M1 [%]		87.4
Dist 3dB Peak [mm]		15.8

Warning(s) / Error(s)

Details	Area Scan	Zoom Scan
Warning(s)		
Error(s)		

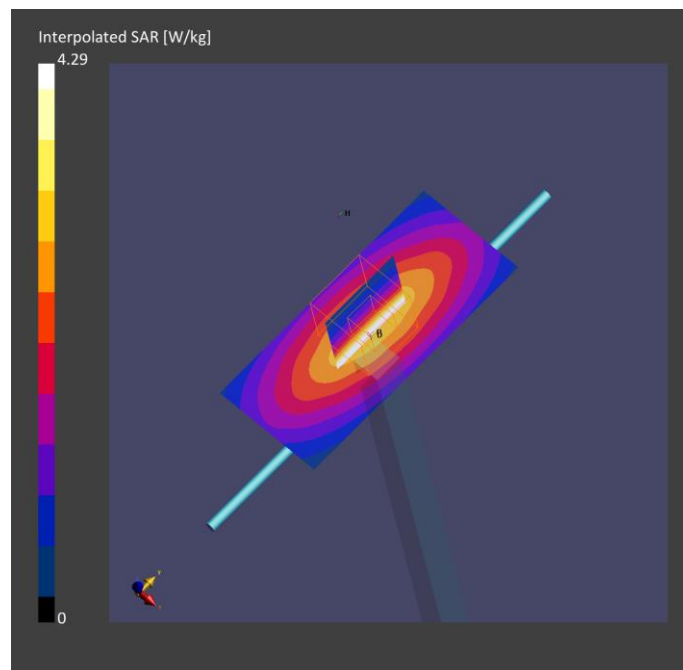

Validation results in 900 MHz Band for Body TSL

Model, Manufacturer	Dimensions [mm]	IMEI	DUT Type
Device,	50.0 x 10.0 x 8.0		Dipole

Exposure Conditions

Phantom Section, TSL	Position, Test Distance [mm]	Band	Group, UID	Frequency [MHz], Channel Number	Conversion Factor	TSL Conductivity [S/m]	TSL Permittivity
Flat, MSL	,		CW, 0--	900.0, 0	9.75	1.04	53.8

Hardware Setup

Phantom	TSL, Measured Date	Probe, Calibration Date	DAE, Calibration Date
ELI V4.0 (20deg probe tilt) - 1060	MSL900V2-2022-09-29 , --	EX3DV4 - SN7461, 2022-08-25	DAE4 Sn1690, 2021-09-08

Scan Setup

	Area Scan	Zoom Scan
Grid Extents [mm]	40.0 x 90.0	30.0 x 30.0 x 30.0
Grid Steps [mm]	10.0 x 15.0	6.0 x 6.0 x 1.5
Sensor Surface [mm]	3.0	1.4
Graded Grid	Yes	Yes
Grading Ratio	1.5	1.5
MAIA	N/A	N/A
Surface Detection	VMS + 6p	VMS + 6p
Scan Method	Measured	Measured

Measurement Results

	Area Scan	Zoom Scan
Date	2022-11-08, 12:25	2022-11-08, 12:30
psSAR1g [W/kg]	2.84	2.81
psSAR10g [W/kg]	1.84	1.82
Power Drift [dB]	0.02	0.03
Power Scaling	Disabled	Disabled
Scaling Factor [dB]		
TSL Correction	Positive only	Positive only
M2/M1 [%]		87.1
Dist 3dB Peak [mm]		14.4

Warning(s) / Error(s)

Details	Area Scan	Zoom Scan
Warning(s)		
Error(s)		

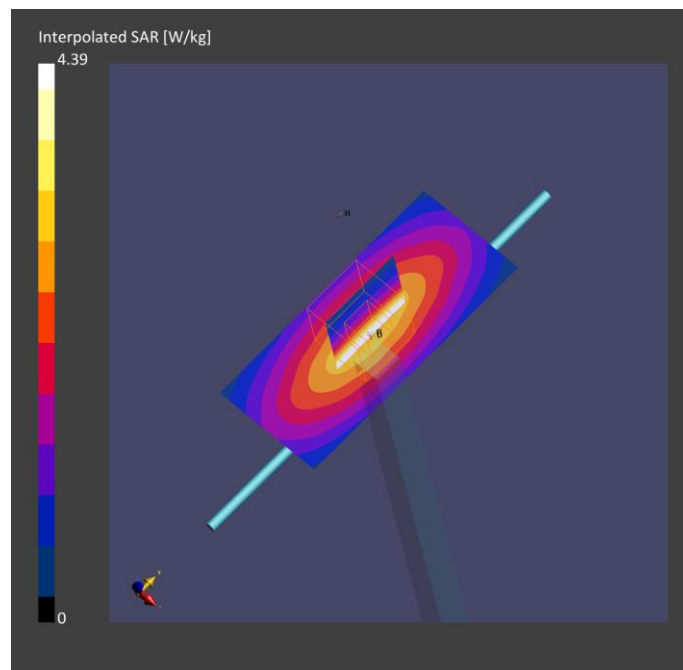

Validation results in 1800 MHz Band for Head TSL

Model, Manufacturer	Dimensions [mm]	IMEI	DUT Type
Device,	50.0 x 10.0 x 8.0		Dipole

Exposure Conditions

Phantom Section, TSL	Position, Test Distance [mm]	Band	Group, UID	Frequency [MHz], Channel Number	Conversion Factor	TSL Conductivity [S/m]	TSL Permittivity
Flat, HSL	,		, 0--	1800.0, 0	8.3	1.37	40.0

Hardware Setup

Phantom	TSL, Measured Date	Probe, Calibration Date	DAE, Calibration Date
ELI V4.0 (20deg probe tilt) - 1060	HBBL 600-10000V6 - 1700-1920MHz - 2022-10-26 , --	EX3DV4 - SN7461, 2022-08-25	DAE4 Sn1690, 2021-09-08

Scan Setup

	Area Scan	Zoom Scan
Grid Extents [mm]	40.0 x 90.0	30.0 x 30.0 x 30.0
Grid Steps [mm]	10.0 x 15.0	6.0 x 6.0 x 1.5
Sensor Surface [mm]	3.0	1.4
Graded Grid	Yes	Yes
Grading Ratio	1.5	1.5
MAIA	N/A	N/A
Surface Detection	VMS + 6p	VMS + 6p
Scan Method	Measured	Measured

Measurement Results

	Area Scan	Zoom Scan
Date	2022-10-26, 20:12	2022-10-26, 20:17
psSAR1g [W/kg]	9.77	9.56
psSAR10g [W/kg]	5.10	4.95
Power Drift [dB]	0.01	0.02
Power Scaling	Disabled	Disabled
Scaling Factor [dB]		
TSL Correction	Positive only	Positive only
M2/M1 [%]		82.8
Dist 3dB Peak [mm]		9.7

Warning(s) / Error(s)

Details	Area Scan	Zoom Scan
Warning(s)		
Error(s)		

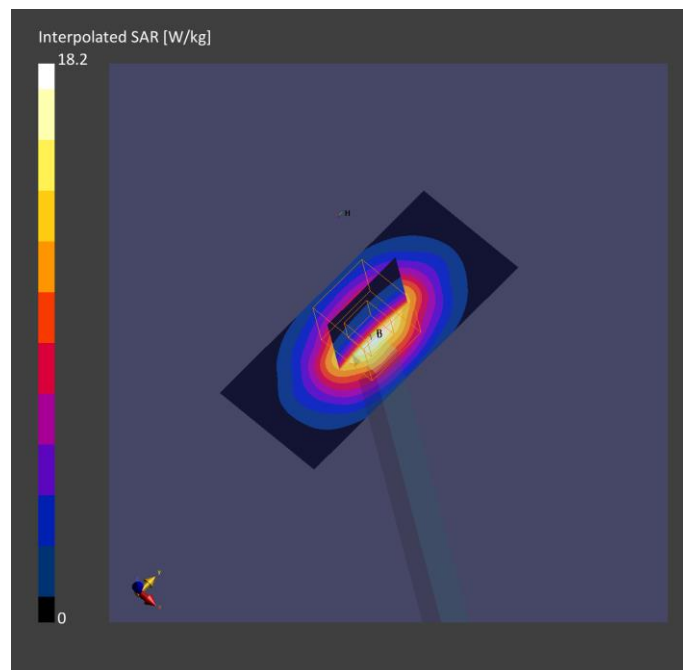

Validation results in 1800 MHz Band for Body TSL

Model, Manufacturer	Dimensions [mm]	IMEI	DUT Type
Device,	50.0 x 10.0 x 8.0		Dipole

Exposure Conditions

Phantom Section, TSL	Position, Test Distance [mm]	Band	Group, UID	Frequency [MHz], Channel Number	Conversion Factor	TSL Conductivity [S/m]	TSL Permittivity
Flat, MSL	,		CW, 0--	1800.0, 0	8.28	1.52	53.2

Hardware Setup

Phantom	TSL, Measured Date	Probe, Calibration Date	DAE, Calibration Date
ELI V4.0 (20deg probe tilt) - 1060	MBBL1550-1950V3-2022-11-09 , --	EX3DV4 - SN7461, 2022-08-25	DAE4 Sn1690, 2021-09-08

Scan Setup

	Area Scan	Zoom Scan
Grid Extents [mm]	40.0 x 90.0	30.0 x 30.0 x 30.0
Grid Steps [mm]	10.0 x 15.0	6.0 x 6.0 x 1.5
Sensor Surface [mm]	3.0	1.4
Graded Grid	Yes	Yes
Grading Ratio	1.5	1.5
MAIA	N/A	N/A
Surface Detection	VMS + 6p	VMS + 6p
Scan Method	Measured	Measured

Measurement Results

	Area Scan	Zoom Scan
Date	2022-11-09, 10:54	2022-11-09, 10:59
psSAR1g [W/kg]	10.1	9.78
psSAR10g [W/kg]	5.19	5.09
Power Drift [dB]	0.01	0.01
Power Scaling	Disabled	Disabled
Scaling Factor [dB]		
TSL Correction	Positive only	Positive only
M2/M1 [%]		84.2
Dist 3dB Peak [mm]		9.6

Warning(s) / Error(s)

Details	Area Scan	Zoom Scan
Warning(s)		
Error(s)		

