



TAOGLAS®



Datasheet

Part No:
PCS.26.C

Description:

Low profile LTE SMD Mount Dielectric Antenna
Designed for 698 – 2170MHz

Features:

Surface Mount Distribution (SMD) - Supplied on Tape & Reel
Covering 698 – 2170MHz
Dimensions: 54.6 x 13 x 3.2 mm
RoHS & REACH Compliant

Taoglas Customer Approval Sheet

Document Number: SPE-20-8-93

Specification Revision: B

Part Number: PCS.26.C

Product Description: Low Profile SMD Mount Dielectric Antenna for 698 - 2170MHz

Customer Name: ResMed

Customer Number: RES002

Issue Date: September 23rd, 2020

Signed on behalf of ResMed:

Name: (Block Capitals) Adam Panarello

Signature: *Adam Panarello*

Date: 24 / 09 / 2020

1. Introduction	4
2. Specifications	5
3. Antenna Characteristics	6
4. Radiation Patterns	8
5. Mechanical Drawing	13
6. Footprint	14
7. Solder Reflow Recommendation	15
8. Packaging	16
<hr/>	
Changelog	17

Taoglas makes no warranties based on the accuracy or completeness of the contents of this document and reserves the right to make changes to specifications and product descriptions at any time without notice. Taoglas reserves all rights to this document and the information contained herein. Reproduction, use or disclosure to third parties without express permission is strictly prohibited.



1. Introduction



The Taoglas PCS.26.C is a low-profile SMD (Surface Mount Distribution) embedded antenna designed for direct mount on a device PCB. Designed to cover LTE frequencies between 698 – 2170Mhz, it provides high efficiency over LTE and allows for fallback to 3G/2G when required. It measures 54.6 x 13 x 3.2mm and the rectangular shape and small size make it very easy to integrate into most PCB's. The PCS.26.C works best when mounted directly on the edge of the PCB.

The PCS.26.C comes packaged in tape and reel format, allowing it to be mounted via pick and place to allow for reflow soldering. This antenna is recommended for use with ground-plane lengths of 100mm or more for maximum efficiency, optimum ground plane size is 130 x 55mm.

Contact your regional Taoglas sales office for more information or support on integrating the PCS.26.C into your device.

2. Specifications

LTE Antenna								
Band	Frequency (MHz)	Efficiency (%)	Average Gain (dB)	Peak Gain (dB)	VSWR	Impedance	Polarization	Radiation Pattern
LTE700	698 ~ 806	55-65	-2.8 to -1.8	1.5 - 2	<3.5:1	50 Ω	Linear	Omni
DCS	1710 ~ 1880	55-65	-3	2.5 – 4.5				
PCS	1850 ~ 1990	55-60	-3 to -2	2.5				
UMTS1	1920 ~ 2170	55-68	-3 to -2.2	2.5 - 4				

*Note: The PCS.26.C performance was measured on a 130 x 55 mm ground plane.

Mechanical	
Dimensions	54.6mm x 13mm x 3.2mm
Weight	2g
Material	FR4
Co-planarity	Follows IPC-TM-650 2.4.22 and has a value of <0.41mm
Environmental	
Storage Temperature *	-40°C to 85°C
Usage Temperature	-40°C to 85°C
Humidity	Non-condensing 65°C 95% RH
Moisture Sensitivity Level	3

*Packaging should only be opened prior to product usage, failure to do so may have an adverse effect on antenna performance.

3. Antenna Characteristics

3.1 Return Loss

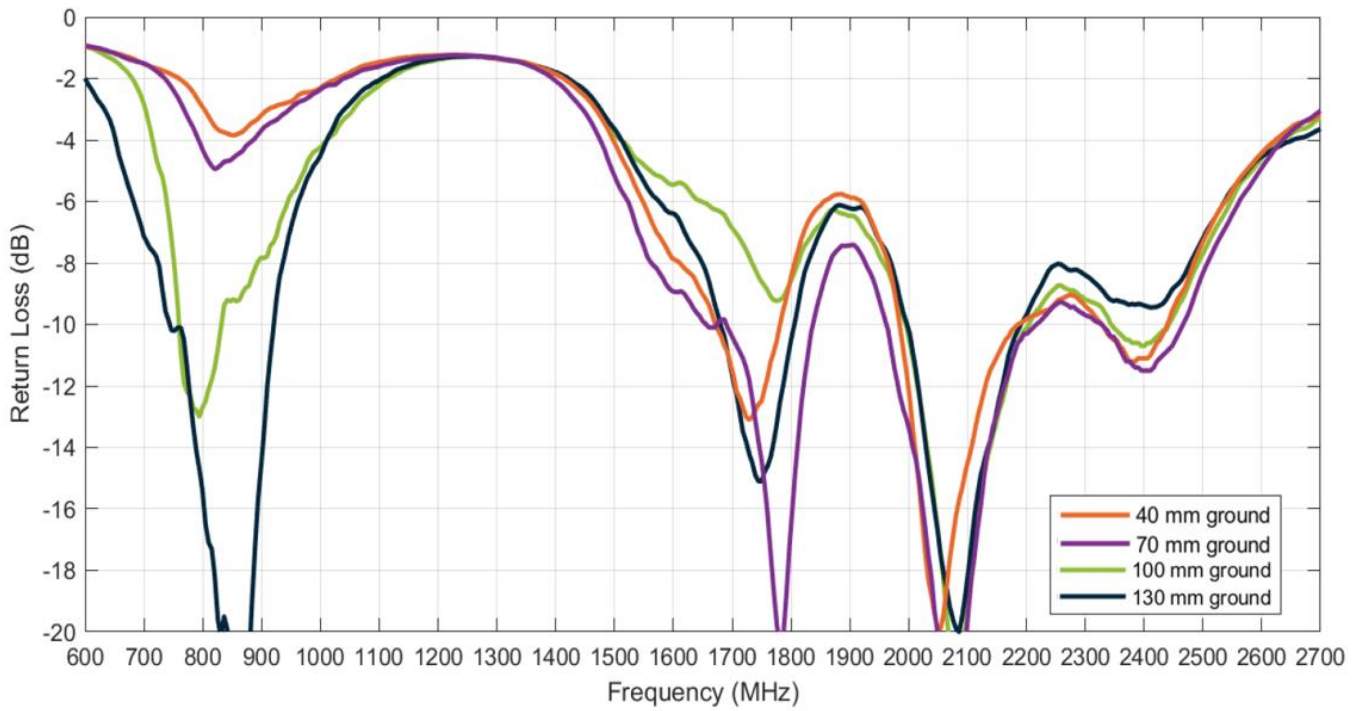

3.2 Efficiency

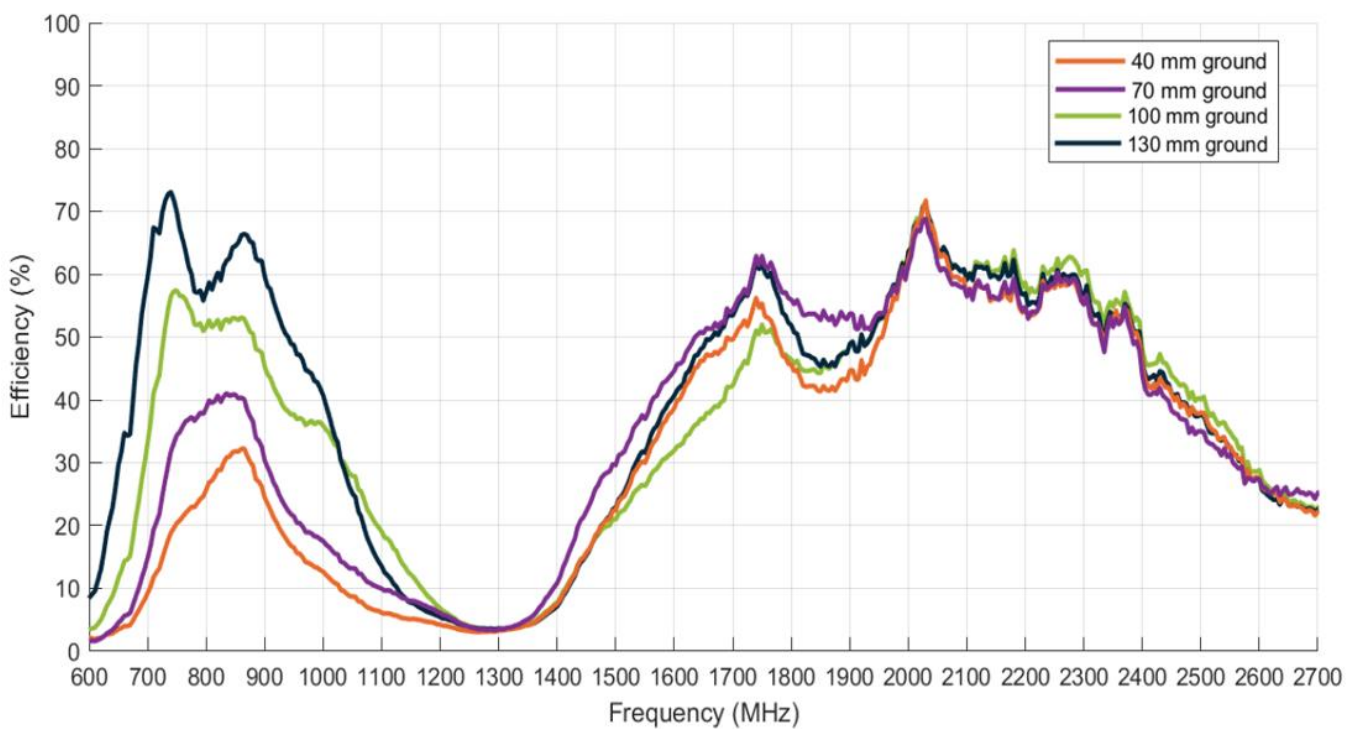

3.3 Average Gain

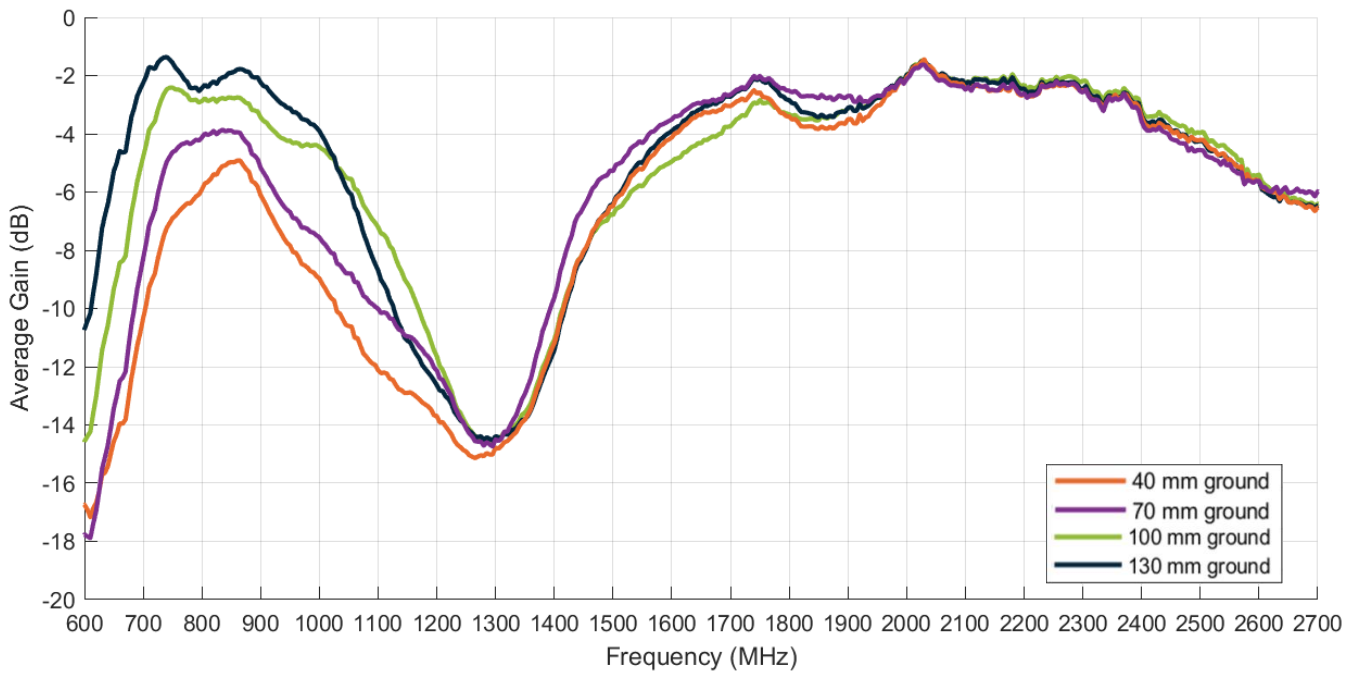

3.4 Peak Gain

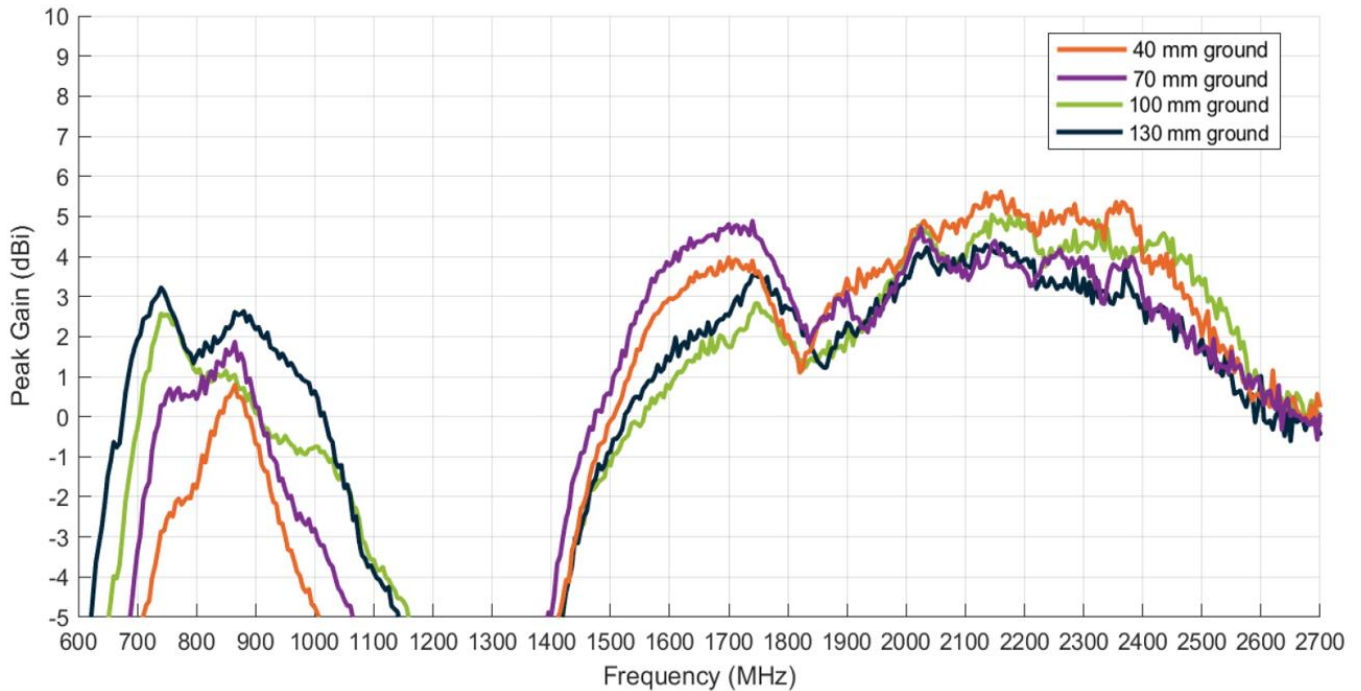

4. Radiation Patterns

4.1 Test Setup

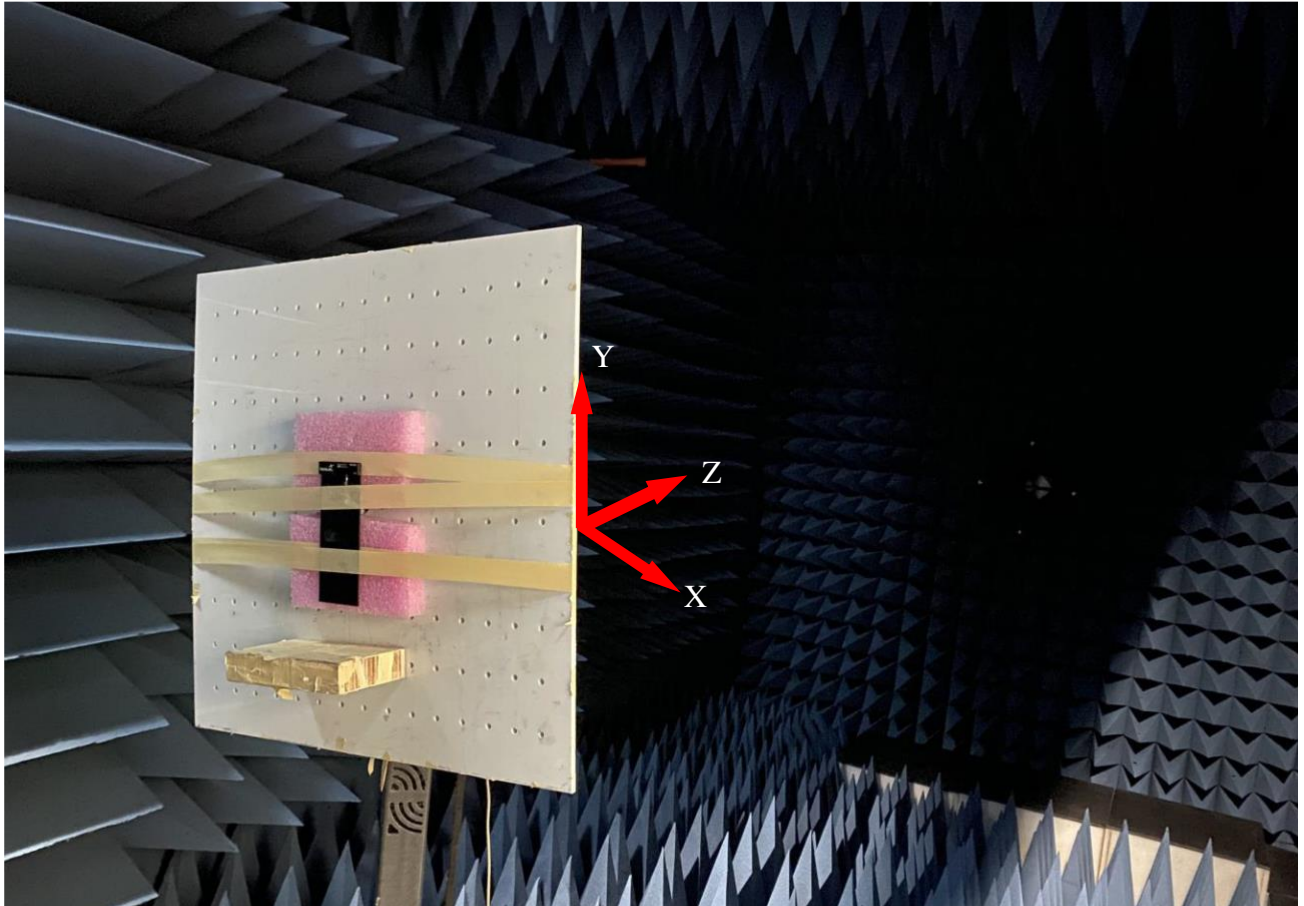

*Note: The PCS.26.C performance was measured on the PCSD.26.C Evaluation Board – A 130 x 55 mm ground plane.

4.2 700 MHz 3D and 2D Radiation Patterns

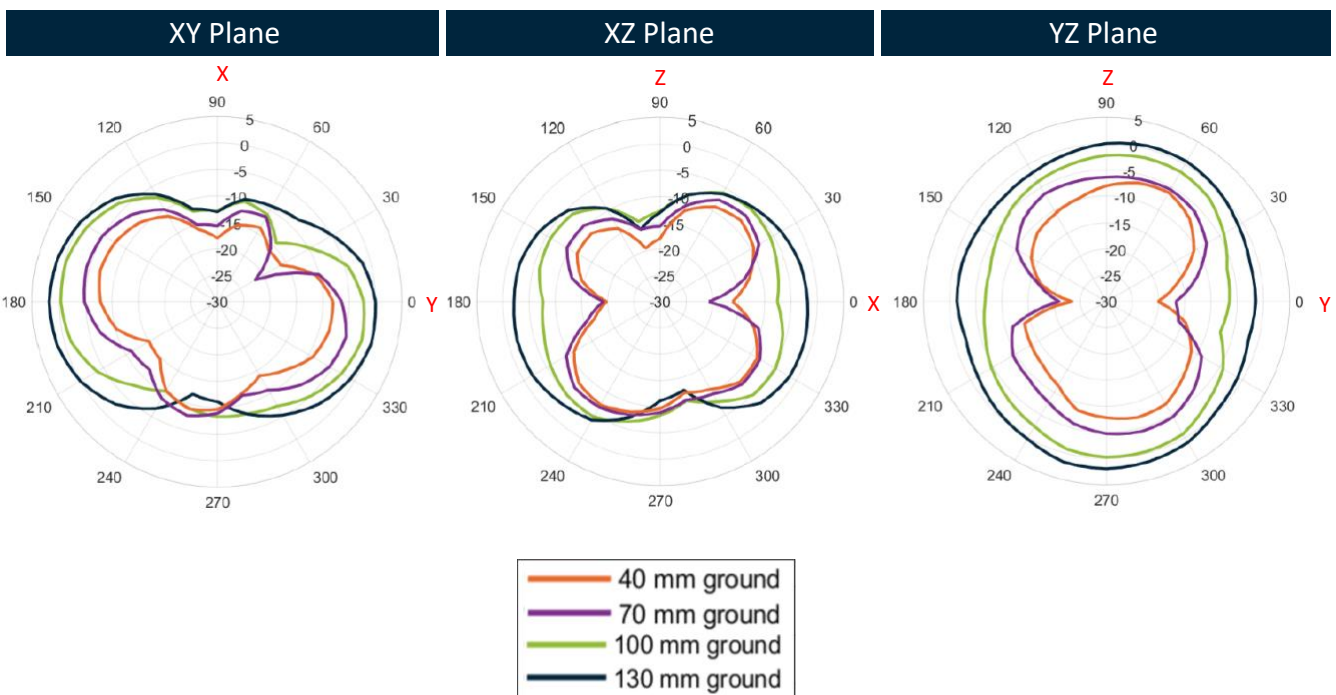
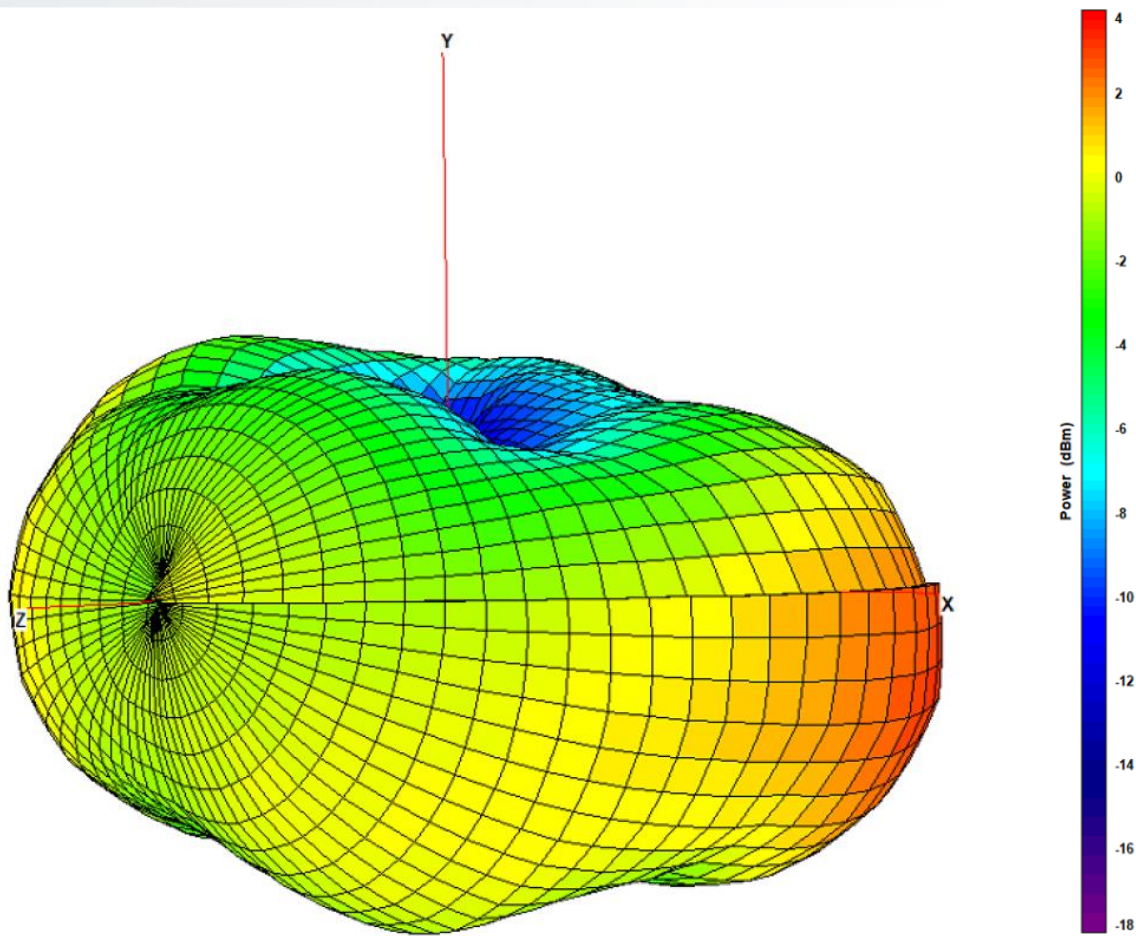

4.3 750 MHz 3D and 2D Radiation Patterns

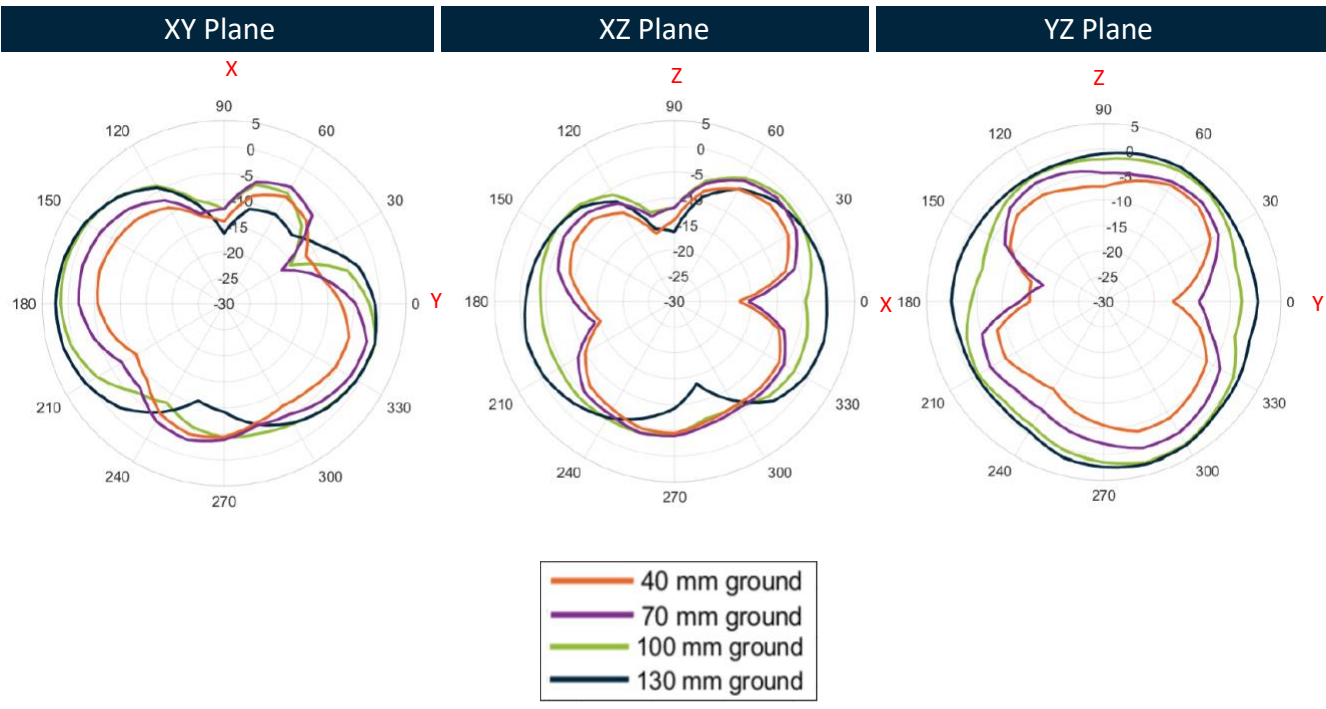
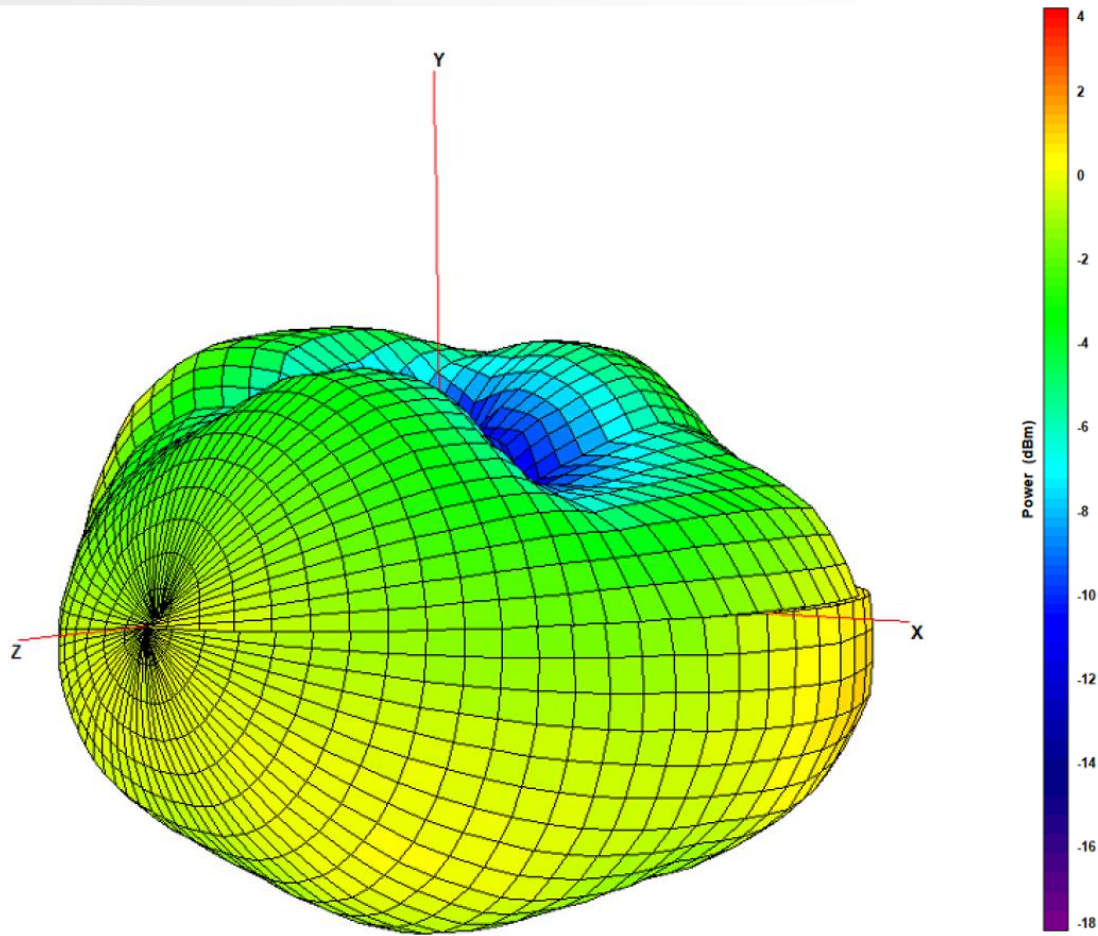

4.4 1710 MHz 3D and 2D Radiation Patterns

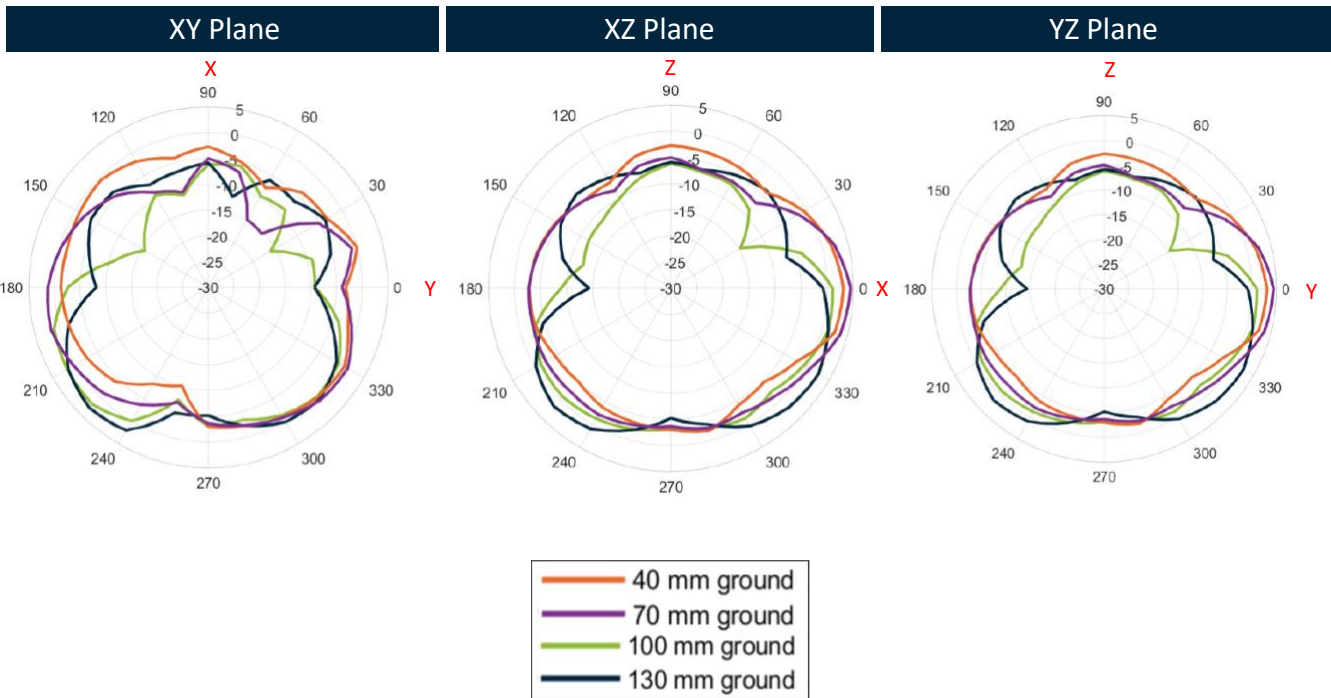
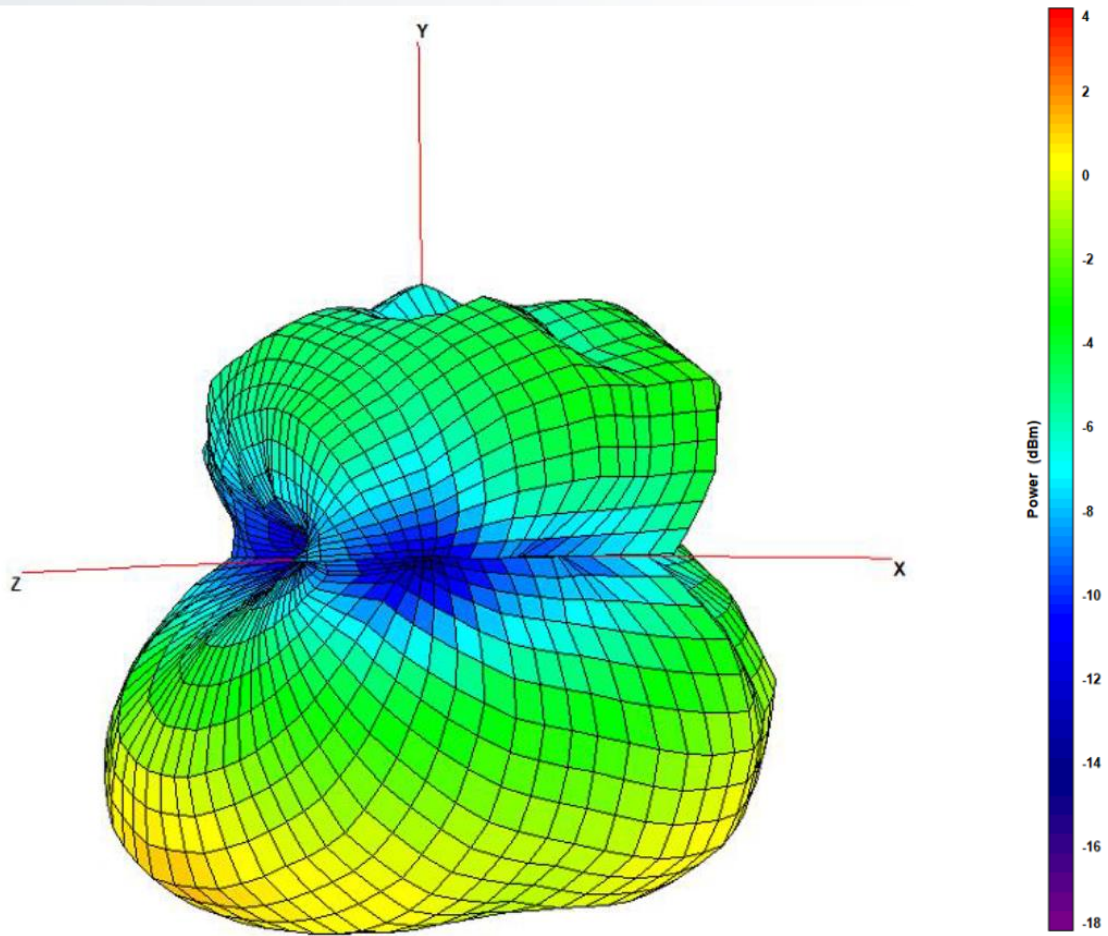

4.5 1880 MHz 3D and 2D Radiation Patterns

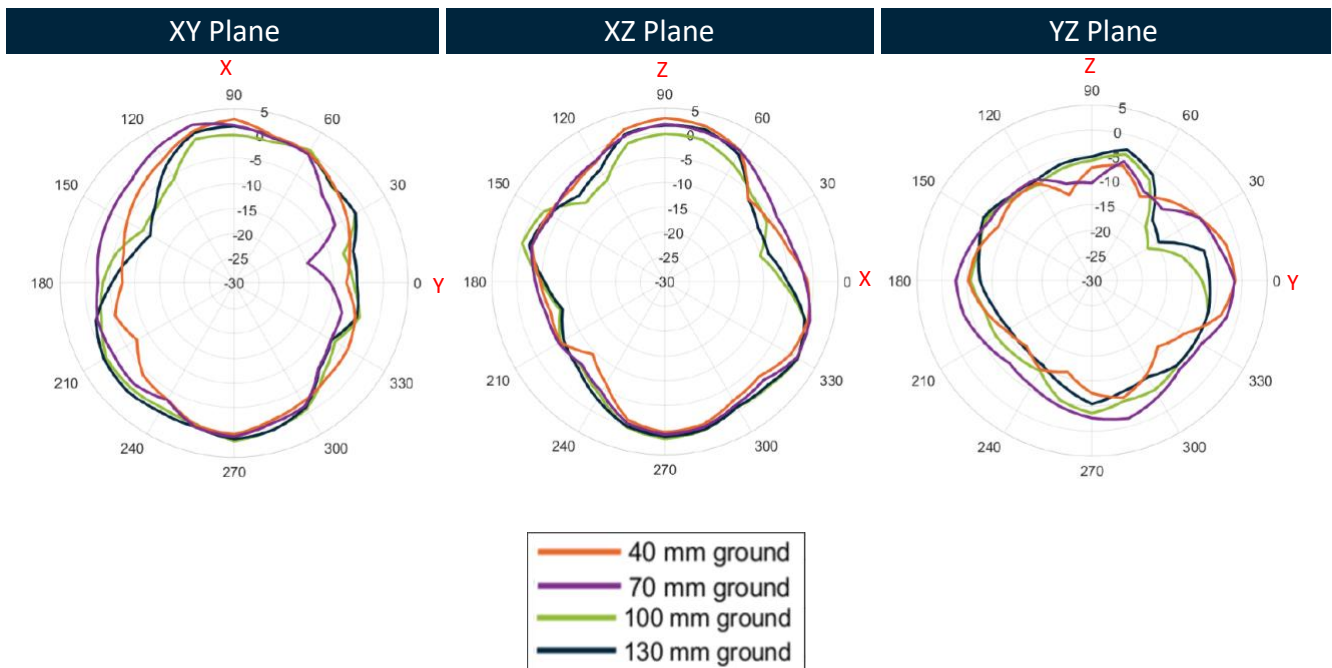
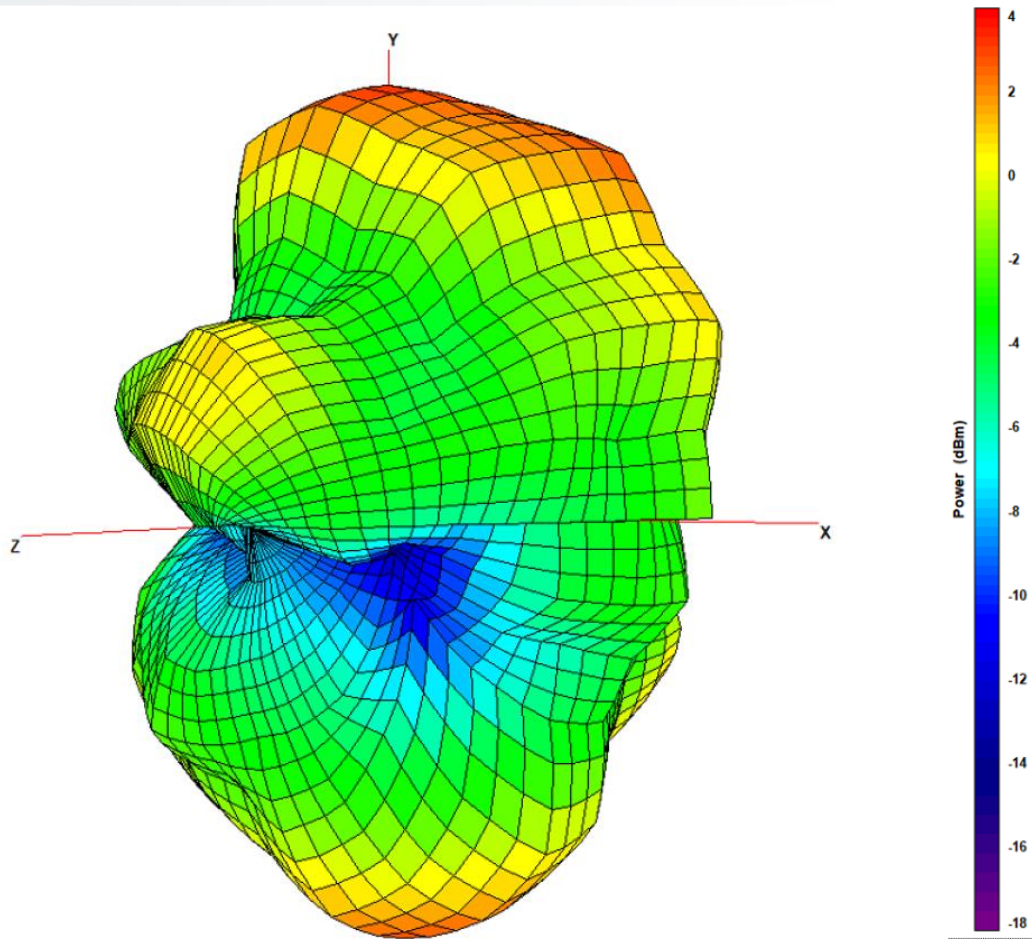

4.5 2170 MHz 3D and 2D Radiation Patterns

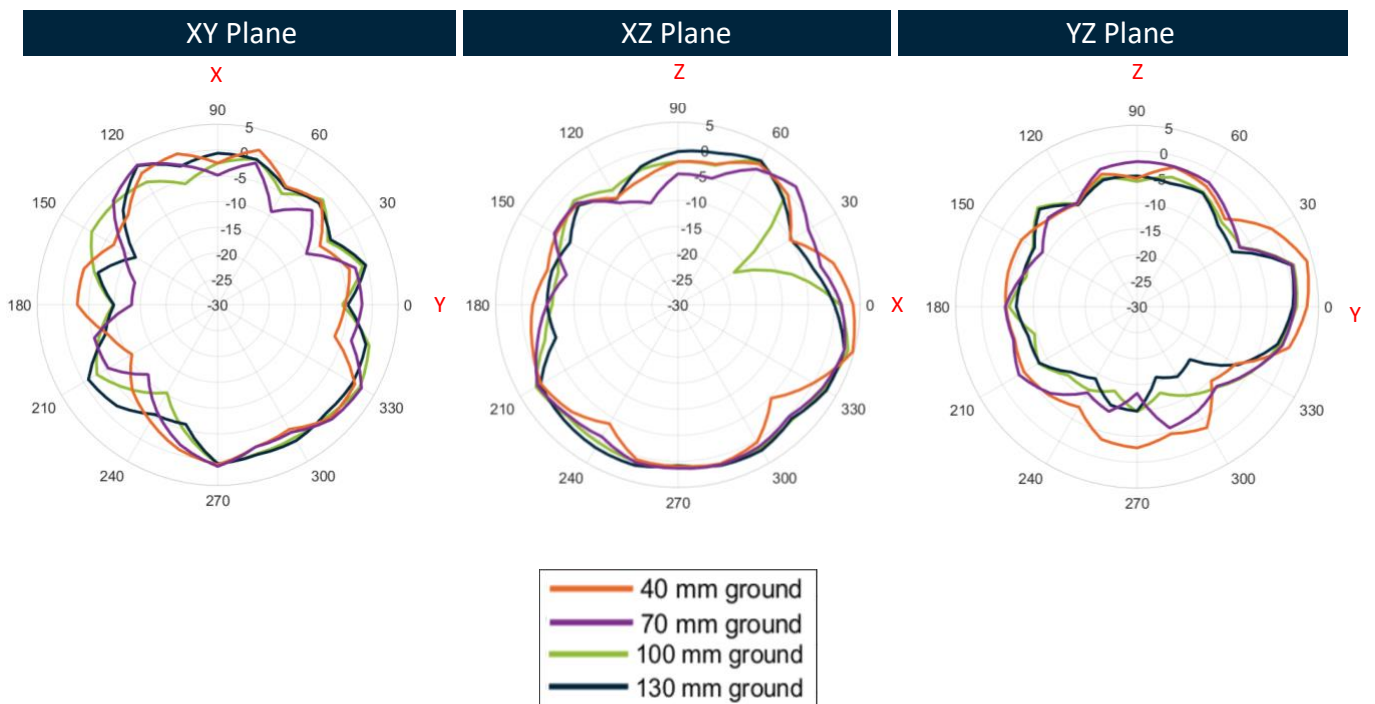
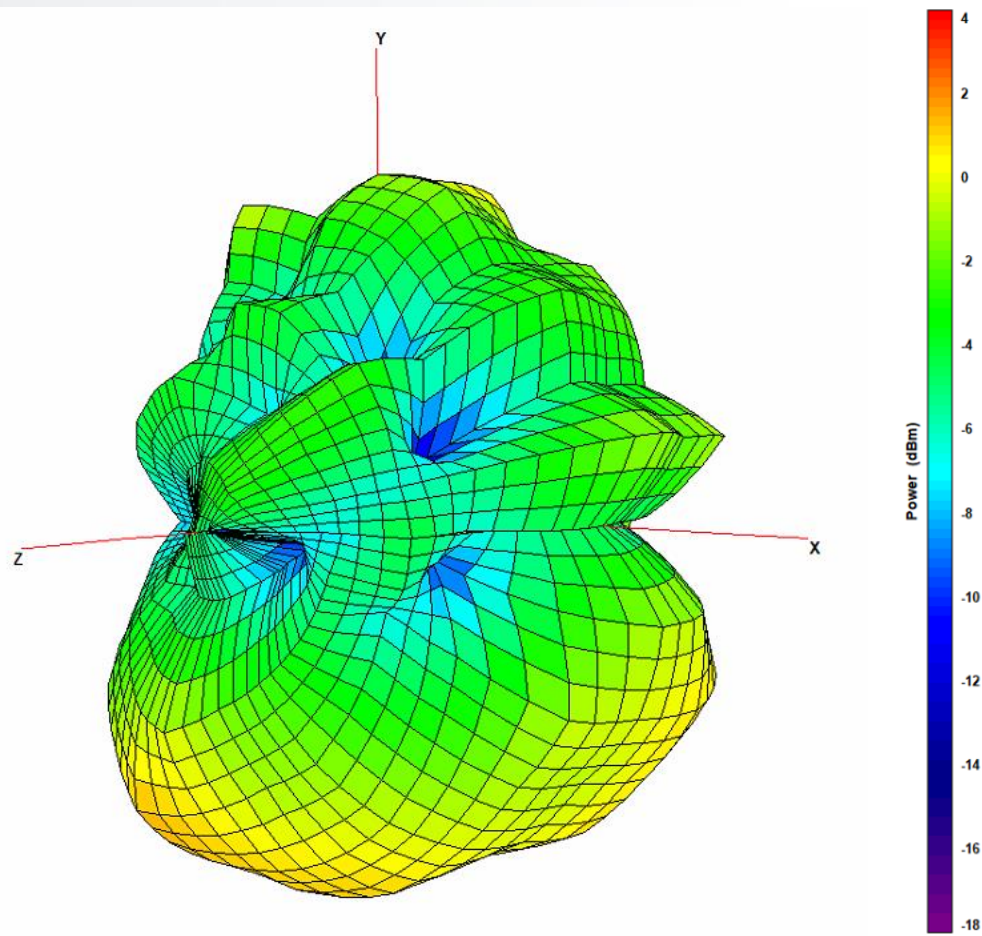

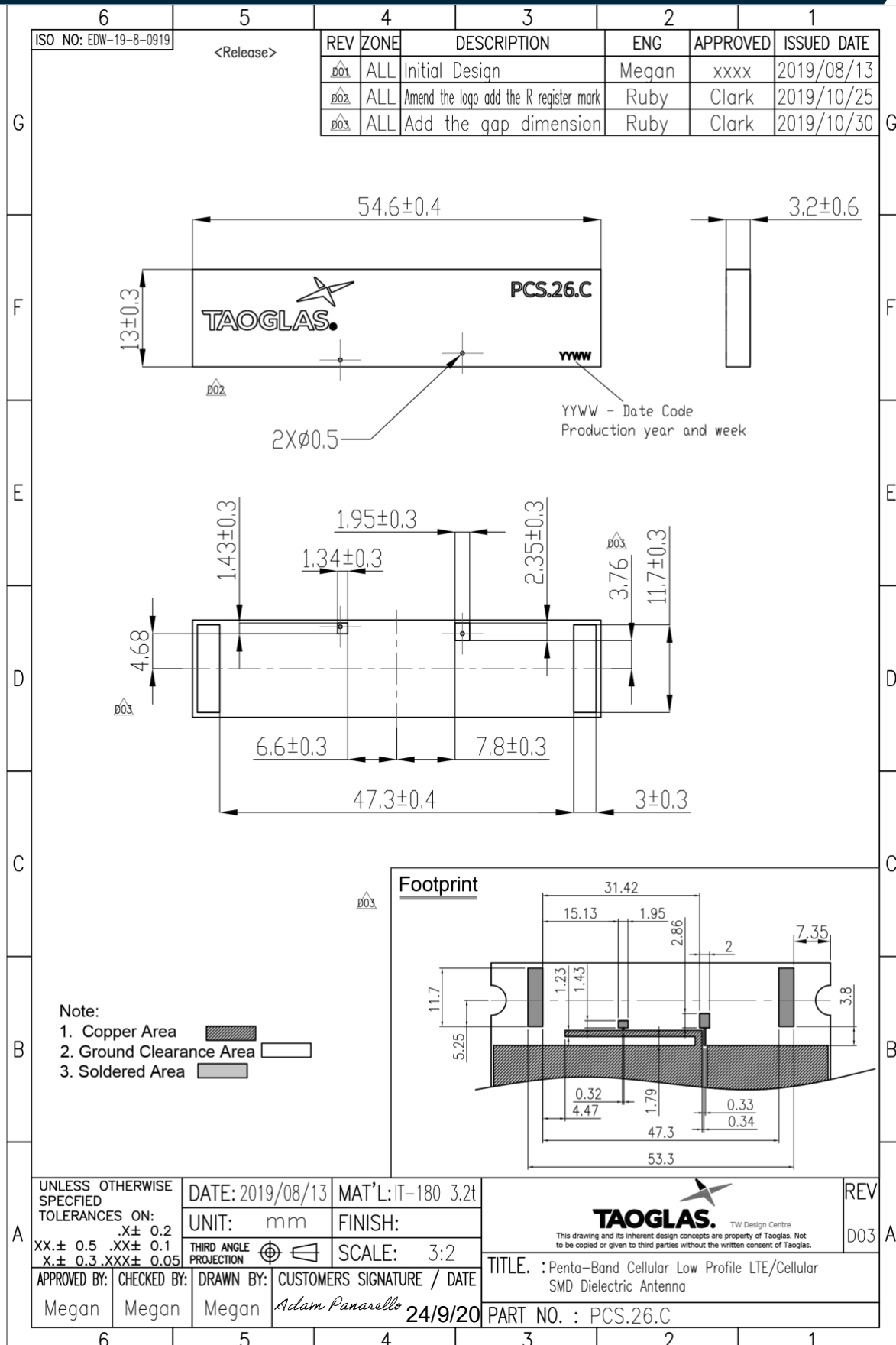

5. Mechanical Drawing (Units: mm)

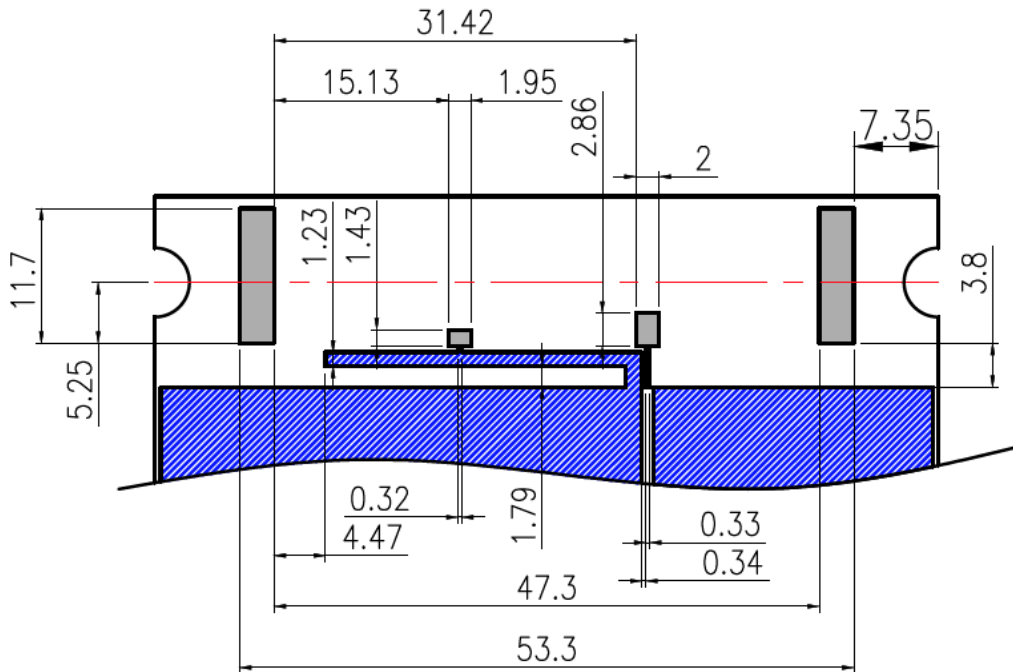

6. Footprint



Note:

1. Copper Area 
2. Ground Clearance Area 
3. Soldered Area 

7. Solder Reflow Recommendations

The PCS.26.C can be assembled by following the recommended soldering temperatures are as follows:

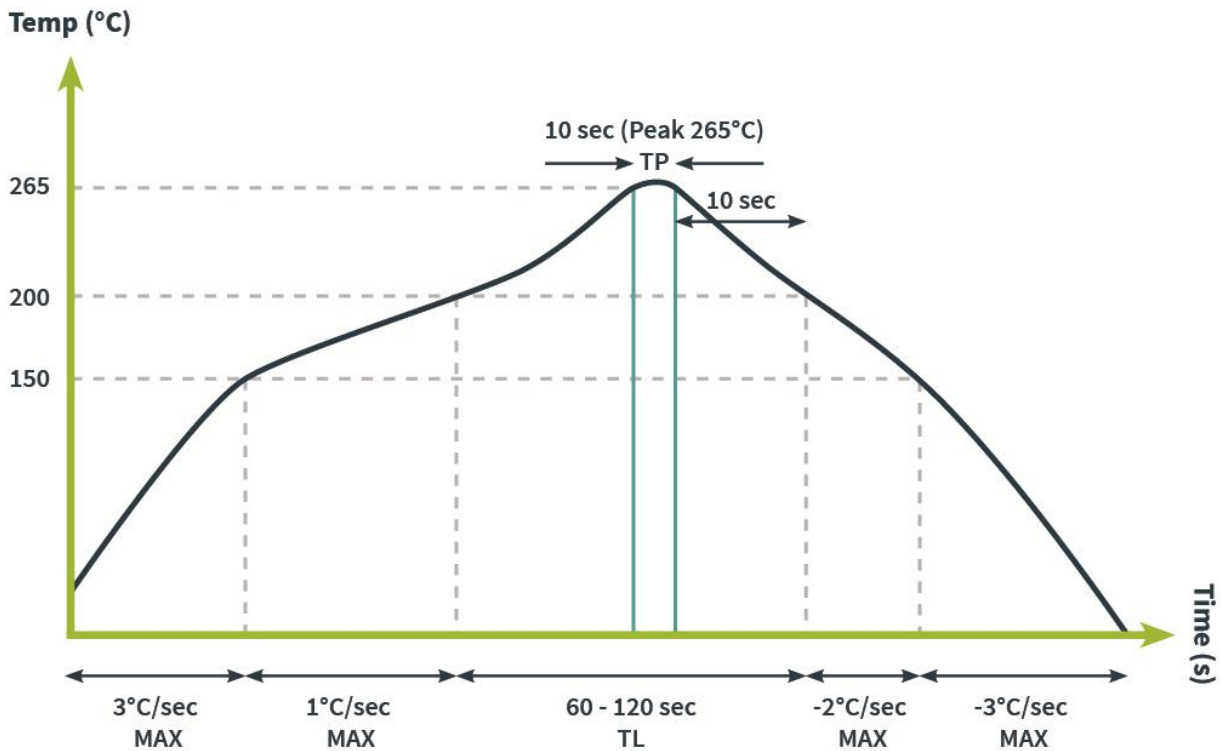

*Temperatures listed within a tolerance of +/- 10⁰ C

The PCS.26.C is not limited to the number of passes through the reflow process. Smaller components are typically mounted on the first pass, however, we do advise mounting the PCS.26.C when placing larger components on the board during subsequent reflows.

8. Packaging

800 pcs PCS.26.C per Reel
 Dimensions - 330*330*72.5mm
 Weight - 3.6Kg

Label as follows:

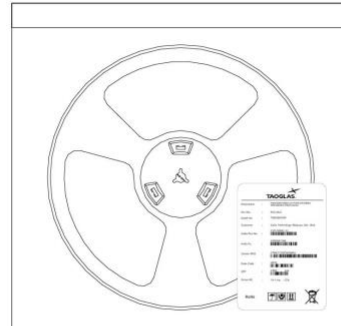

800 pcs PCS.26.C - 1 Reel in 1 Small Box
 Dimensions - 340*340*90mm
 Weight - 3.65Kg

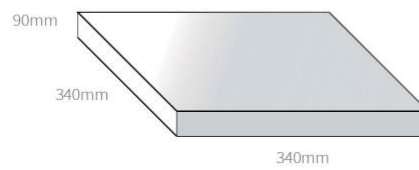

2,400 pcs PCS.26.C - 3 Small Boxed in 1 Larger Carton
 Carton Dimensions - 370*360*275mm
 Weight -11Kg

Label as follows:

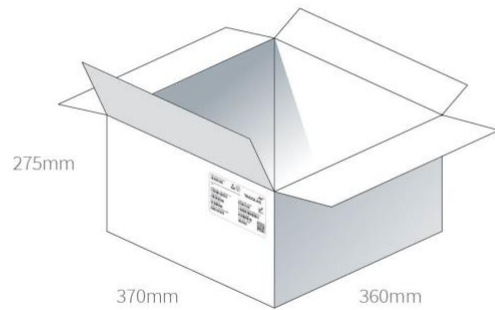

Pallet Dimensions 1200*1000*1320mm
 24 Cartons per Pallet
 6 Cartons per layer
 4 Layers

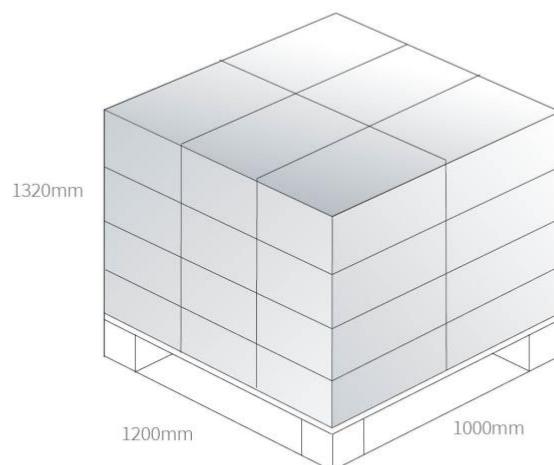



www.taoglas.com

