

Test Report No:
 NIE: 72943RRF.004A1

Partial Test Report USA FCC Part 90

(*) Identification of item tested	Continuous Positive Airway Pressure (CPAP) Device
(*) Trademark	ResMed
(*) Model and /or type reference	39485
(*) Derived model not tested	39517, 39518, 39519, 39520, 39521, 39522
Other identification of the product	HW version: R390-7654 SW version: SW04600 FCC ID: 2ACHL-AIR11M1G22 IC: 9103A-AIR11M1G22
(*) Features	LTE Cat-M1, BLE
Applicant	ResMed Pty Ltd 1 Elizabeth Macarthur Drive, Bella Vista, NSW, 2153 Australia
Test method requested, standard	USA FCC Part 90 (10-1-21 Edition). ANSI C63.26-2015. KDB 971168 D01 Power Meas License Digital Systems v03r01, April 2018. <ul style="list-style-type: none"> • FCC 90.635 (b): RF output power • FCC 90.691 Emission mask • FCC 90.691 Radiated Emissions
Approved by (name / position & signature)	Rafael López Martín EMC Consumer & RF Lab. Manager
Date of issue	2022-12-23
Report template No.	FDT08_24 (*) "Data provided by the client"

Index

Competences and guarantees	3
General conditions	3
Uncertainty	3
Data provided by the client.....	3
Usage of samples	5
Test sample description	5
Identification of the client.....	7
Testing period and place.....	7
Document history	7
Environmental conditions	7
Remarks and comments	8
Testing verdicts.....	8
Summary	9
Appendix A: Test results for FCC 90	10

Competences and guarantees

DEKRA Testing and Certification is a testing laboratory accredited by the National Accreditation Body (ENAC - Entidad Nacional de Acreditación) to perform the tests indicated in the Certificate No. 51/LE 147.

DEKRA Testing and Certification is an FCC-recognized accredited testing laboratory with appropriate scope of accreditation that covers the performed tests in this report.

In order to assure the traceability to other national and international laboratories, DEKRA Testing and Certification has a calibration and maintenance program for its measurement equipment.

DEKRA Testing and Certification guarantees the reliability of the data presented in this report, which is the result of the measurements and the tests performed to the item under test on the date and under the conditions stated on the report and it is based on the knowledge and technical facilities available at DEKRA Testing and Certification at the time of performance of the test.

DEKRA Testing and Certification is liable to the client for the maintenance of the confidentiality of all information related to the item under test and the results of the test.

The results presented in this Test Report apply only to the particular item under test established in this document.

IMPORTANT: No parts of this report may be reproduced or quoted out of context, in any form or by any means, except in full, without the previous written permission of DEKRA Testing and Certification.

General conditions

1. This report is only referred to the item that has undergone the test.
2. This report does not constitute or imply on its own an approval of the product by the Certification Bodies or competent Authorities.
3. This document is only valid if complete; no partial reproduction can be made without previous written permission of DEKRA Testing and Certification S.A.U.
4. This test report cannot be used partially or in full for publicity and/or promotional purposes without previous written permission of DEKRA Testing and Certification S.A.U. and the Accreditation Bodies.

Uncertainty

Uncertainty (factor $k=2$) was calculated according to the DEKRA Testing and Certification S.A.U. internal document PODT000.

Data provided by the client

The following data has been provided by the client:

1. Information relating to the description of the sample ("Identification of the item tested", "Trademark", "Model and/or type reference tested").
2. The sample of the model 39485 is a CPAP device with integrated cellular and Bluetooth connectivity.
3. Derived models not tested. These models have been declared by the supplier of the sample as being the same as the model under test.



Date: 25-Oct-2022

DECLARATION OF EQUIVALENCE

This document declares that the following designated products are equivalent to the unit under test **39485**.

Model Name / Product Code	Marketing Name
39517	AirSense 11 AutoSet USA
39518	AirSense 11 CPAP USA
39519	AirSense 11 Elite USA
39520	AirSense 11 AutoSet CAN
39521	AirSense 11 CPAP CAN
39522	AirSense 11 Elite CAN

All the above stated products and the unit under test - 39485 have the same cellular hardware and firmware.

Applicant:

Company Name: ResMed Pty Ltd
Address: 1 Elizabeth Macarthur Drive,
Bella Vista NSW 2153
Australia

By,



Christopher Jenkins
Title: Manager – Systems Engineering
Company: ResMed Pty Ltd
Telephone: +61 2 8884 1517
e-mail: Christopher.jenkins@resmed.com.au

DEKRA Testing and Certification S.A.U. declines any responsibility with respect to the information provided by the client and that may affect the validity of results.

Usage of samples

Samples undergoing test have been selected by: The client.

- Sample S/01 is composed of the following elements:

Control No.	Description	Model	Serial No.	Date of reception
72943/046	Continuous Positive Airway Pressure (CPAP) Device	39485	22221830061	2022/09/19
72943/010	Water Tank	HumidAir11	--	2022/08/02
72943/018	AC/DC Adapter	390000	0001RP02	2022/08/02
72943/025	Power Cord	-	--	2022/08/02
66427/006	Climate Line	AIR11	--	2020/12/29

Sample S/01 has undergone the following test(s): The Radiated tests indicated in Appendix A.

- Sample S/02 is composed of the following elements:

Control No.	Description	Model	Serial No.	Date of reception
72943/045	Continuous Positive Airway Pressure (CPAP) Device	39485	22221830059	2022/09/19
72943/020	AC/DC Adapter	390000	0001RG02	2022/08/02

Sample S/02 has undergone the following test(s): The Conducted tests indicated in Appendix A.

Test sample description

Ports.....:	Port name and description	Cable					
		Specified max length [m]	Attached during test	Shielded	Coupled to patient ⁽³⁾		
	Power		<input checked="" type="checkbox"/>	<input type="checkbox"/>	<input type="checkbox"/>		
	--		<input type="checkbox"/>	<input type="checkbox"/>	<input type="checkbox"/>		
Supplementary information to the ports.....:	--						
Rated power supply	Voltage and Frequency		Reference poles				
			L1	L2	L3	N	PE
	<input checked="" type="checkbox"/>	AC: 100-240V~50-60 Hz 2.0A	<input checked="" type="checkbox"/>	<input type="checkbox"/>	<input type="checkbox"/>	<input checked="" type="checkbox"/>	<input type="checkbox"/>
	<input checked="" type="checkbox"/>	AC: 115V~400Hz 1.5A	<input checked="" type="checkbox"/>	<input type="checkbox"/>	<input type="checkbox"/>	<input checked="" type="checkbox"/>	<input type="checkbox"/>
	<input type="checkbox"/>	DC: 12V (DC-DC for Vehicle Use)					
	<input type="checkbox"/>	DC: 24V (DC-DC for Vehicle Use)					
Rated Power.....:	--						
Clock frequencies.....:	N/A						
Other parameters	390000 (PSU Model Number)						
Software version.....:	SW04600 (DUT)						
Hardware version	R390-7654 (DUT)						
Dimensions in cm (W x H x D) ...:	138.5 mm x 259.4 mm x 94.5 mm						
Mounting position	<input checked="" type="checkbox"/>	Table top equipment					
	<input type="checkbox"/>	Wall/Ceiling mounted equipment					
	<input type="checkbox"/>	Floor standing equipment					
	<input type="checkbox"/>	Hand-held equipment					
	<input type="checkbox"/>	Other:					
Modules/parts.....:	Module/parts of test item		Type	Manufacturer			
	Wireless Module		EXS62-W	Thales			
	Bluetooth LE		EFR32BG22	SiLabs			
Accessories (not part of the test item)	Description		Type	Manufacturer			
	--						
	--						
Documents as provided by the applicant.....:	Description		File name	Issue date			
	--						
	--						

⁽³⁾ Only for Medical Equipment

Identification of the client

ResMed Pty Ltd
1 Elizabeth Macarthur Drive, Bella Vista, NSW, 2153
Australia

Testing period and place

Test Location	DEKRA Testing and Certification S.A.U.
Date (start)	2022-10-05
Date (finish)	2022-10-05

Document history

Report number	Date	Description
72943RRF.004	2022-11-25	First release.
72943RRF.004A1	2022-12-23	Second release. This report is modified due to minor typos. This modification test report cancels and replaces the test report 72943RRF004

Environmental conditions

In the control chamber, the following limits were not exceeded during the test:

Temperature	Min. = 15 °C Max. = 35 °C
Relative humidity	Min. = 20 % Max. = 75 %

In the semi-anechoic chamber, the following limits were not exceeded during the test.

Temperature	Min. = 15 °C Max. = 35 °C
Relative humidity	Min. = 20 % Max. = 75 %

In the chamber for conducted measurements, the following limits were not exceeded during the test:

Temperature	Min. = 15 °C Max. = 35 °C
Relative humidity	Min. = 20 % Max. = 75 %

Remarks and comments

The tests have been performed by the technical personnel: Miguel Manuel López, Pablo Redondo, Francisco Javier Fernández, Álvaro Gutiérrez, Sergio Carrasco.

Used instrumentation:

Control No.	Equipment	Model	Manufacturer	Next Calibration
6791	SEMIANECHOIC ABSORBER LINED CHAMBER IV	FACT 3 200 STP	ETS LINDGREN	2024-06-07
6792	SHIELDED ROOM	S101	ETS LINDGREN	--
7817	EMI TEST RECEIVER 2Hz-44GHz	ESW44	ROHDE AND SCHWARZ	2024-01-24
3783	PRE-AMPLIFIER G>30dB 1GHz-18GHz	BLMA 0118-3A	BONN ELEKTRONIK	2022-12-01
7862	PRE-AMPLIFIER G>30dB 17-40GHz	BLMA 1840-3G	BONN ELEKTRONIK	2023-02-15
6143	HYBRID BILOG ANTENNA 30MHz-6GHz	3142E	ETS LINDGREN	2023-10-29
6496	HORN ANTENNA 1-18GHz	BBHA 9120 D	SCHWARZBECK	2023-08-24
4657	HORN ANTENNA 18-40GHz	BBHA 9170	SCHWARZBECK	2023-05-05
4609	AC POWER SUPPLY	6490	CHROMA	2022-12-11
6794	SHIELDED ROOM	S101	ETS LINDGREN	--
6667	WIDEBAND RADIO COMMUNICATION TESTER	CMW500	ROHDE AND SCHWARZ	2023-05-31
3342	SIGNAL ANALIZER 20Hz-8GHz	FSQ8	ROHDE AND SCHWARZ	2022-10-06

Testing verdicts

Not applicable:	N/A
Pass:	P
Fail:	F
Not measured:	N/M

Summary

FCC PART 90		
Requirement – Test case	Verdict	Remark
FCC 90.635 (b): RF output power	P	
FCC 2.1047: Modulation characteristics	N/M	(1)
FCC 90.213: Frequency stability	N/M	(1)
FCC 2.1049: Occupied Bandwidth	N/M	(1)
FCC 90.691: Spurious emissions at antenna terminals	N/M	(1)
FCC 90.691: Spurious emissions at antenna terminals (Emission mask requirements for EA-based systems)	P	
FCC 90.691: Radiated emissions	P	
<u>Supplementary information and remarks:</u>		
(1) Test not requested.		

Appendix A: Test results for FCC 90

INDEX

TEST CONDITIONS.....	12
RF Output Power	13
Spurious Emissions at Antenna Terminals at Block Edges	23
Radiated Emissions.....	31

TEST CONDITIONS

(*): Declared by the Applicant.

POWER SUPPLY (*):

Vnormal: Preliminary scan determined 115Vac / 60Hz as worst case of power supply.

Type of Power Supply: Mains Supply.

ANTENNA (*):

Band	Gain (dBi)	Type
LTE 5	+2.2	Ceramic
LTE 26	+2.2	Ceramic

TEST FREQUENCIES:

LTE Band 26. Sub-band 814-824 MHz. QPSK and 16QAM modulations:

	Channel (Frequency, MHz)				
	BW=1.4 MHz	BW=3 MHz	BW=5 MHz	BW=10 MHz	BW=15 MHz
Low	26697 (814.7)	26705 (815.5)	26715 (816.5)	N/A	N/A
Middle	26740 (819)	26740 (819)	26740 (819)	26740 (819)	N/A
High	26783 (823.3)	26775 (822.5)	26765 (821.5)	N/A	N/A

LTE Band 26. Sub-band 824-849 MHz. QPSK and 16QAM modulations:

	Channel (Frequency, MHz)			
	BW=1.4 MHz	BW=3 MHz	BW=5 MHz	BW=10 MHz
Low	20407 (824.70)	20415 (825.50)	20425 (826.50)	20450 (829.00)

NOTE: Only band edge was tested on low channels of Sub-band 824-849 MHz to ensure conformity of band edge at 824 MHz.

LTE Band 26. Cross-rule Channel (824 MHz). QPSK and 16QAM modulations:

Channel (Frequency, MHz)				
BW=1.4 MHz	BW=3 MHz	BW=5 MHz	BW=10 MHz	BW=15 MHz
26790 (824)	26790 (824)	26790 (824)	26790 (824)	26790 (824)

RF Output Power

Limits

FCC §90.635 (b): The maximum output power of the transmitter for mobile stations is 100 Watts (20 dBW).

Method

The conducted RF output power measurements were made at the RF output terminals of the EUT using the power meter of the Universal Radio Communication tester R&S CMW500, selecting maximum transmission power of the EUT and different modes of modulation.

The maximum equivalent isotropically radiated power (e.i.r.p.) is calculated by adding the declared maximum antenna gain (dBi).

The maximum effective radiated power e.r.p. is calculated from the maximum equivalent isotropically radiated power (e.i.r.p.) by subtracting 2.15 dB:

$$E.R.P. = E.I.R.P. - 2.15 \text{ dB}$$

Test setup



Results

CONDUCTED AVERAGE POWER

LTE Band 26. Sub-band 814-824 MHz:

Measurements required on one frequency near top channel and one frequency near bottom channel, according to FCC § 15.31 (m).

LTE Band 26. Sub-band 814-824 MHz. QPSK modulation. BW=1.4 MHz.

Channel	Low	High
Maximum declared antenna gain (dBi)	2.2	
Measured maximum average power (dBm) at antenna port	19.81	19.86
Maximum equivalent isotropically radiated power (E.I.R.P.) (dBm)	22.01	22.06
Maximum effective radiated power E.R.P. (dBm)	19.86	19.91
Measurement uncertainty (dB)	<±0.94	

Average Power Worst Case: Modulation QPSK. RB Size: 1. RB Offset: 0.

LTE Band 26. Sub-band 814-824 MHz. 16QAM modulation. BW=1.4 MHz.

Channel	Low	High
Maximum declared antenna gain (dBi)	2.2	
Measured maximum average power (dBm) at antenna port	18.63	19.42
Maximum equivalent isotropically radiated power (E.I.R.P.) (dBm)	20.83	21.62
Maximum effective radiated power E.R.P. (dBm)	18.68	19.47
Measurement uncertainty (dB)	<±0.94	

Average Power Worst Case: Modulation 16QAM. RB Size: 1. RB Offset: 0.

LTE Band 26. Sub-band 814-824 MHz. QPSK modulation. BW=3 MHz.

Channel	Low	High
Maximum declared antenna gain (dBi)	2.2	
Measured maximum average power (dBm) at antenna port	19.71	19.86
Maximum equivalent isotropically radiated power (E.I.R.P.) (dBm)	21.91	22.06
Maximum effective radiated power E.R.P. (dBm)	19.76	19.91
Measurement uncertainty (dB)	<±0.94	

Average Power Worst Case: Modulation QPSK. RB Size: 1. RB Offset: 0.

LTE Band 26. Sub-band 814-824 MHz. 16QAM modulation. BW=3 MHz.

Channel	Low	High
Maximum declared antenna gain (dBi)	2.2	
Measured maximum average power (dBm) at antenna port	18.62	18.51
Maximum equivalent isotropically radiated power (E.I.R.P.) (dBm)	20.82	20.71
Maximum effective radiated power E.R.P. (dBm)	18.67	18.56
Measurement uncertainty (dB)	<±0.94	

Average Power Worst Case: Modulation 16QAM. RB Size: 1. RB Offset: 0.

LTE Band 26. Sub-band 814-824 MHz. QPSK modulation. BW=5 MHz.

Channel	Low	High
Maximum declared antenna gain (dBi)	2.2	
Measured maximum average power (dBm) at antenna port	19.82	19.62
Maximum equivalent isotropically radiated power (E.I.R.P.) (dBm)	22.02	21.82
Maximum effective radiated power E.R.P. (dBm)	19.87	19.67
Measurement uncertainty (dB)	<±0.94	

Average Power Worst Case: Modulation QPSK. RB Size: 1. RB Offset: 0.

LTE Band 26. Sub-band 814-824 MHz. 16QAM modulation. BW=5 MHz.

Channel	Low	High
Maximum declared antenna gain (dBi)	2.2	
Measured maximum average power (dBm) at antenna port	19.43	19.46
Maximum equivalent isotropically radiated power (E.I.R.P.) (dBm)	21.63	21.66
Maximum effective radiated power E.R.P. (dBm)	19.48	19.51
Measurement uncertainty (dB)	<±0.94	

Average Power Worst Case: Modulation 16QAM. RB Size: 1. RB Offset: 0.

LTE Band 26. Sub-band 814-824 MHz. QPSK modulation. BW=10 MHz.

Channel	Middle
Maximum declared antenna gain (dBi)	2.2
Measured maximum average power (dBm) at antenna port	19.65
Maximum equivalent isotropically radiated power (E.I.R.P.) (dBm)	21.85
Maximum effective radiated power E.R.P. (dBm)	19.70
Measurement uncertainty (dB)	<±0.94

Average Power Worst Case: Modulation QPSK. RB Size: 1. RB Offset: 0.

LTE Band 26. Sub-band 814-824 MHz. 16QAM modulation. BW=10 MHz.

Channel	Middle
Maximum declared antenna gain (dBi)	2.2
Measured maximum average power (dBm) at antenna port	19.49
Maximum equivalent isotropically radiated power (E.I.R.P.) (dBm)	21.69
Maximum effective radiated power E.R.P. (dBm)	19.54
Measurement uncertainty (dB)	<±0.94

Average Power Worst Case: Modulation 16QAM. RB Size: 1. RB Offset: 0.

LTE Band 26. Cross-rule Channel 824 MHz:

LTE Band 26 Cross-rule Channel 824 MHz. QPSK modulation. BW=1.4 MHz.

Channel	824 MHz
Maximum declared antenna gain (dBi)	2.2
Measured maximum average power (dBm) at antenna port	20.39
Maximum equivalent isotropically radiated power (E.I.R.P.) (dBm)	22.59
Maximum effective radiated power E.R.P. (dBm)	20.44
Measurement uncertainty (dB)	<±0.94

Average Power Worst Case: Modulation QPSK. RB Size: 1. RB Offset: 0.

LTE Band 26 Cross-rule Channel 824 MHz. 16QAM modulation. BW=1.4 MHz.

Channel	824 MHz
Maximum declared antenna gain (dBi)	2.2
Measured maximum average power (dBm) at antenna port	20.35
Maximum equivalent isotropically radiated power (E.I.R.P.) (dBm)	22.55
Maximum effective radiated power E.R.P. (dBm)	20.40
Measurement uncertainty (dB)	<±0.94

Average Power Worst Case: Modulation 16QAM. RB Size: 1. RB Offset: 0.

LTE Band 26 Cross-rule Channel 824 MHz. QPSK modulation. BW=3 MHz.

Channel	824 MHz
Maximum declared antenna gain (dBi)	2.2
Measured maximum average power (dBm) at antenna port	20.33
Maximum equivalent isotropically radiated power (E.I.R.P.) (dBm)	22.53
Maximum effective radiated power E.R.P. (dBm)	20.38
Measurement uncertainty (dB)	<±0.94

Average Power Worst Case: Modulation QPSK. RB Size: 1. RB Offset: 0.

LTE Band 26 Cross-rule Channel 824 MHz. 16QAM modulation. BW=3 MHz.

Channel	824 MHz
Maximum declared antenna gain (dBi)	2.2
Measured maximum average power (dBm) at antenna port	19.21
Maximum equivalent isotropically radiated power (E.I.R.P.) (dBm)	21.41
Maximum effective radiated power E.R.P. (dBm)	19.26
Measurement uncertainty (dB)	<±0.94

Average Power Worst Case: Modulation 16QAM. RB Size: 1. RB Offset: 0.

LTE Band 26 Cross-rule Channel 824 MHz. QPSK modulation. BW=5 MHz.

Channel	824 MHz
Maximum declared antenna gain (dBi)	2.2
Measured maximum average power (dBm) at antenna port	20.39
Maximum equivalent isotropically radiated power (E.I.R.P.) (dBm)	22.59
Maximum effective radiated power E.R.P. (dBm)	20.44
Measurement uncertainty (dB)	<±0.94

Average Power Worst Case: Modulation QPSK. RB Size: 1. RB Offset: 0.

LTE Band 26 Cross-rule Channel 824 MHz. 16QAM modulation. BW=5 MHz.

Channel	824 MHz
Maximum declared antenna gain (dBi)	2.2
Measured maximum average power (dBm) at antenna port	20.30
Maximum equivalent isotropically radiated power (E.I.R.P.) (dBm)	22.50
Maximum effective radiated power E.R.P. (dBm)	20.35
Measurement uncertainty (dB)	<±0.94

Average Power Worst Case: Modulation 16QAM. RB Size: 1. RB Offset: 0.

LTE Band 26 Cross-rule Channel 824 MHz. QPSK modulation. BW=10 MHz.

Channel	824 MHz
Maximum declared antenna gain (dBi)	2.2
Measured maximum average power (dBm) at antenna port	20.21
Maximum equivalent isotropically radiated power (E.I.R.P.) (dBm)	22.41
Maximum effective radiated power E.R.P. (dBm)	20.26
Measurement uncertainty (dB)	<±0.94

Average Power Worst Case: Modulation QPSK. RB Size: 1. RB Offset: 0.

LTE Band 26 Cross-rule Channel 824 MHz. 16QAM modulation. BW=10 MHz.

Channel	824 MHz
Maximum declared antenna gain (dBi)	2.2
Measured maximum average power (dBm) at antenna port	19.93
Maximum equivalent isotropically radiated power (E.I.R.P.) (dBm)	22.13
Maximum effective radiated power E.R.P. (dBm)	19.98
Measurement uncertainty (dB)	<±0.94

Average Power Worst Case: Modulation 16QAM. RB Size: 1. RB Offset: 0.

LTE Band 26 Cross-rule Channel 824 MHz. QPSK modulation. BW=15 MHz.

Channel	824 MHz
Maximum declared antenna gain (dBi)	2.2
Measured maximum average power (dBm) at antenna port	20.23
Maximum equivalent isotropically radiated power (E.I.R.P.) (dBm)	22.43
Maximum effective radiated power E.R.P. (dBm)	20.28
Measurement uncertainty (dB)	<±0.94

Average Power Worst Case: Modulation QPSK. RB Size: 6. RB Offset: 0.

LTE Band 26 Cross-rule Channel 824 MHz. 16QAM modulation. BW=15 MHz.

Channel	824 MHz
Maximum declared antenna gain (dBi)	2.2
Measured maximum average power (dBm) at antenna port	20.24
Maximum equivalent isotropically radiated power (E.I.R.P.) (dBm)	22.44
Maximum effective radiated power E.R.P. (dBm)	20.29
Measurement uncertainty (dB)	<±0.94

Average Power Worst Case: Modulation QPSK. RB Size: 5. RB Offset: 0.

Verdict

Pass

Spurious Emissions at Antenna Terminals at Block Edges

Limits

FCC §2.1051 and §22.917:

The power of any emission outside of the authorized operating frequency ranges must be attenuated below the transmitting power (P) by a factor of at least $43 + 10 \log(P)$ dB.

Compliance with these rules is based on the use of measurement instrumentation employing a reference bandwidth as follows:

In the spectrum below 1 GHz, instrumentation should employ a reference bandwidth of 100 kHz or greater. In the 1 MHz bands immediately outside and adjacent to the frequency block, a resolution bandwidth of at least one percent of the emission bandwidth of the fundamental emission of the transmitter may be employed.

RSS-132. Clause 5.5:

Mobile and base station equipment shall comply with the limits below.

In the first 1.0 MHz band immediately outside and adjacent to each of the sub-bands, the power of emissions per any 1% of the occupied bandwidth shall be attenuated (in dB) below the transmitter output power P (dBW) by at least $43 + 10 \log 10 p$ (watts).

FCC §90.691.

(a) Out-of-band emission requirement shall apply only to the “outer” channels included in an EA license and to spectrum adjacent to interior channels used by incumbent licensees. The emission limits are as follows:

(1) For any frequency removed from the EA licensee's frequency block by up to and including 37.5 kHz, the power of any emission shall be attenuated below the transmitter power (P) in watts by at least $116 \log_{10}(f/6.1)$ decibels or $50 + 10 \log_{10}(P)$ decibels or 80 decibels, whichever is the lesser attenuation, where f is the frequency removed from the center of the outer channel in the block in kilohertz and where f is greater than 12.5 kHz.

(2) For any frequency removed from the EA licensee's frequency block greater than 37.5 kHz, the power of any emission shall be attenuated below the transmitter power (P) in watts by at least $43 + 10 \log_{10}(P)$ decibels or 80 decibels, whichever is the lesser attenuation, where f is the frequency removed from the center of the outer channel in the block in kilohertz and where f is greater than 37.5 kHz.

Method

The EUT RF output connector was connected to a spectrum analyzer and to the Universal Radio Communication tester R&S CMW500 (selecting maximum transmission power of the EUT and different modes of modulation) using a 50-Ohm attenuator and a power splitter.

The reading of the spectrum analyser is corrected with the path loss of the connection between the output terminal of the EUT and the input of the spectrum analyzer.

The configuration of modulation which is the worst case for conducted power was used.

As stated in FCC part 22.917 / RSS-132 Clause 5.5, in the 1 MHz bands immediately outside and adjacent to the frequency block or band a resolution bandwidth of at least one percent of the emission bandwidth of the fundamental emission of the transmitter may be employed.

Measurement Limit:

At P_o transmitting power, the specified minimum attenuation $43 + 10 \log_{10} p$ (watts) becomes:

$$P_o \text{ (dBm)} - [43 + 10 \log (P_o \text{ in mwatts}) - 30] = -13 \text{ dBm}$$

Test setup

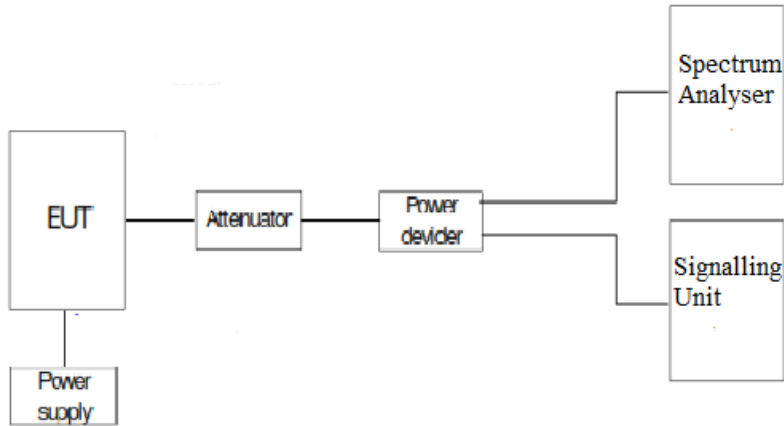

Results

Sub-bands 814-824 MHz & 824-849 MHz:

Preliminary measurements determined the Nominal Bandwidth 1.4 MHz, QPSK modulation as the worst case. Results attached are for this worst-case configuration.

Measurement uncertainty (dB): $<\pm 2.76$

Verdict

Pass

Attachments

Sub-band 814-824 MHz. EA MASK:

Narrow band = 1. RB = 1. Offset = 0. BW = 1.4 MHz

Low Channel:

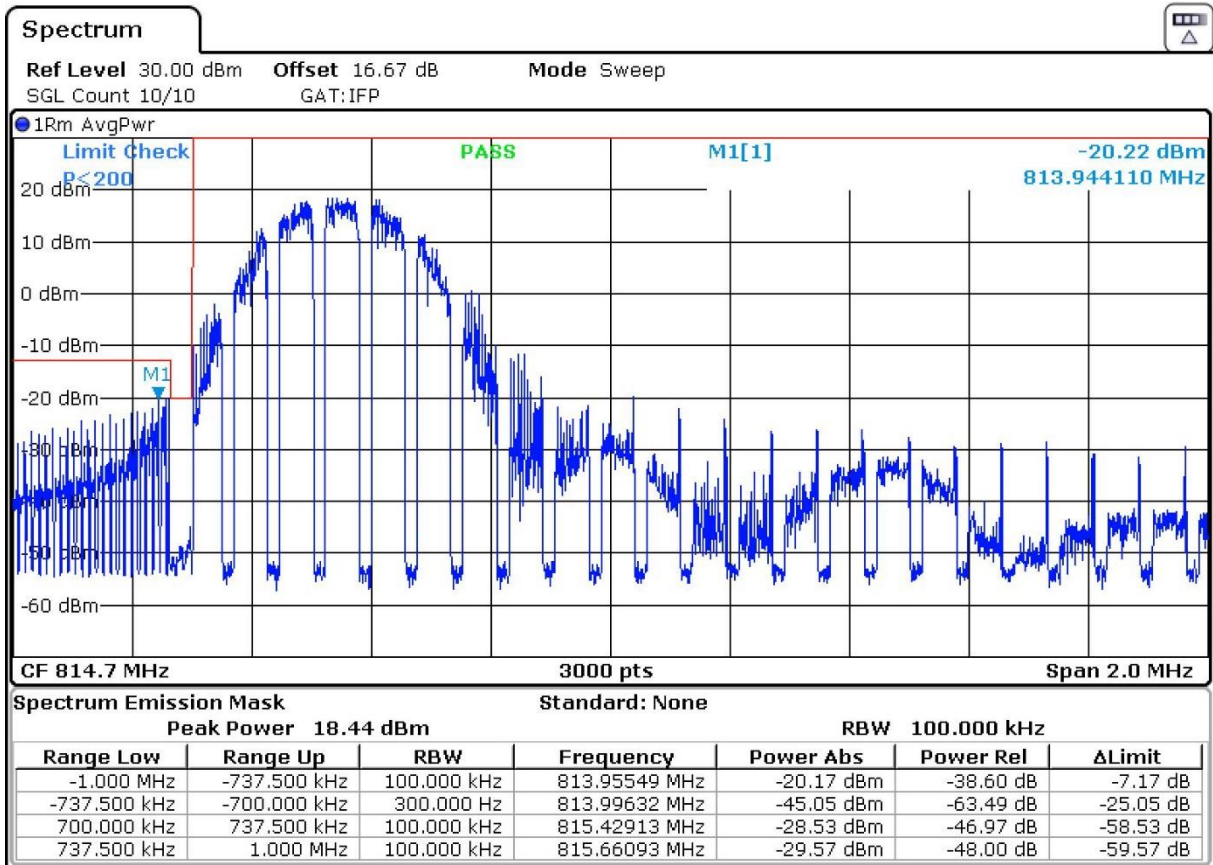

Narrow band = 1. RB = 1. Offset = Max. BW = 1.4 MHz

High Channel:

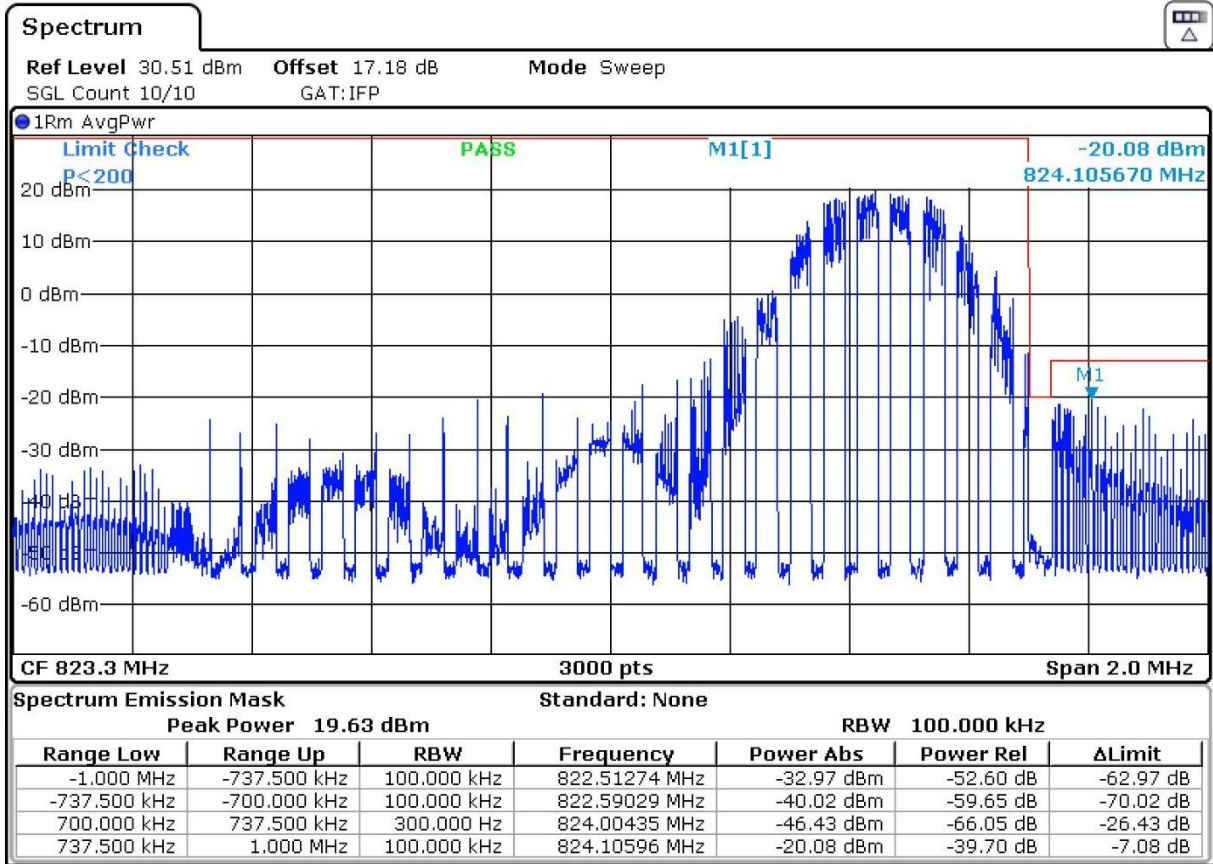

Narrow band = 1. RB = All. Offset = 0. BW = 1.4 MHz

Low Channel:

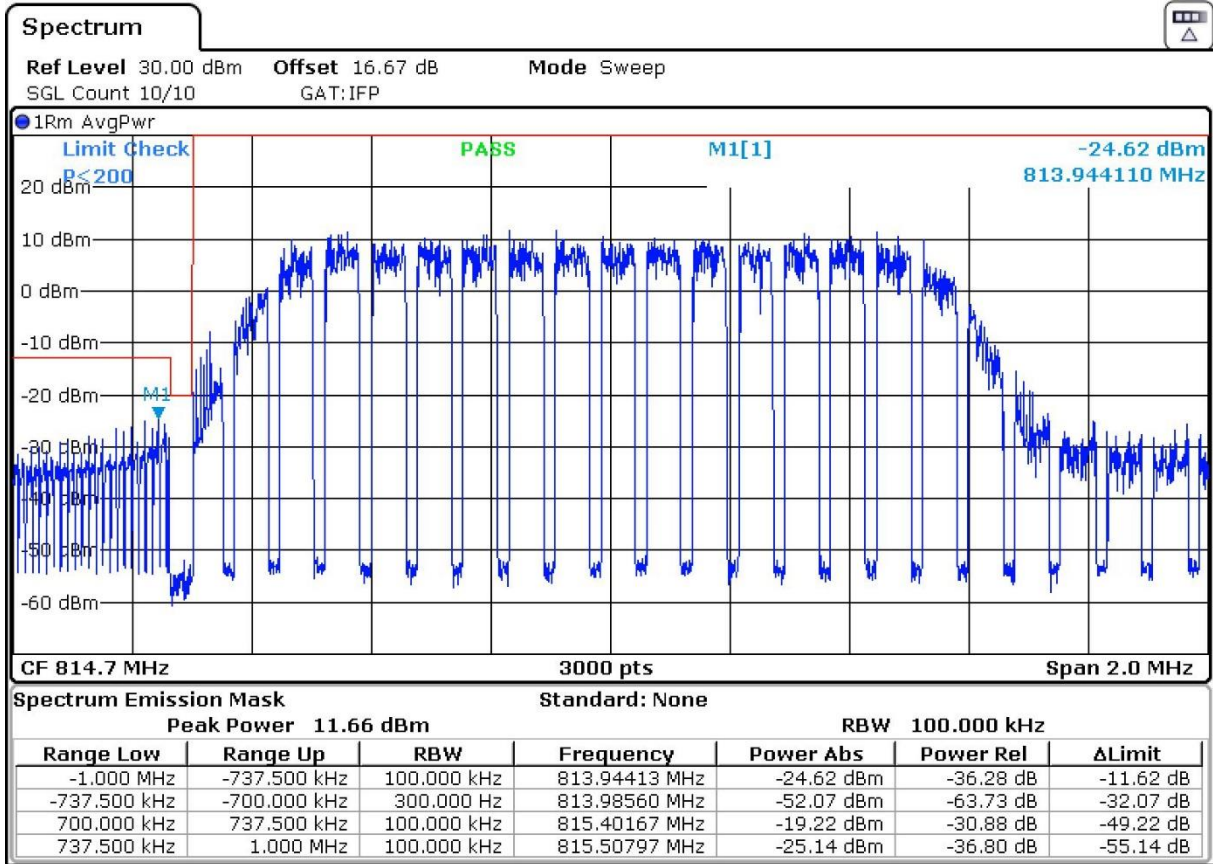

Narrow band = 1. RB = All. Offset = 0. BW = 1.4 MHz

High Channel:

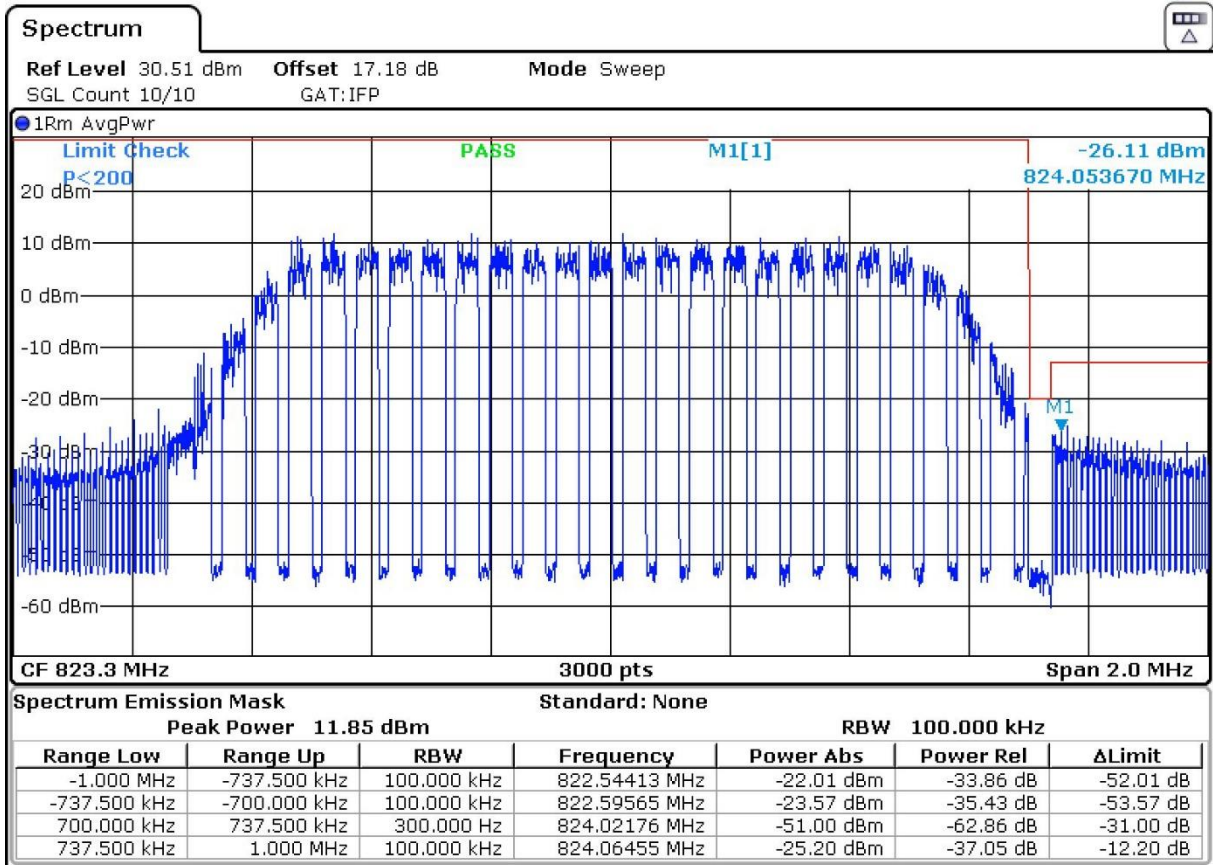

Sub-band 824-849 MHz. Band edge:

Narrow band = 1. RB = 1. Offset = 0. BW = 1.4 MHz.

Low Channel:

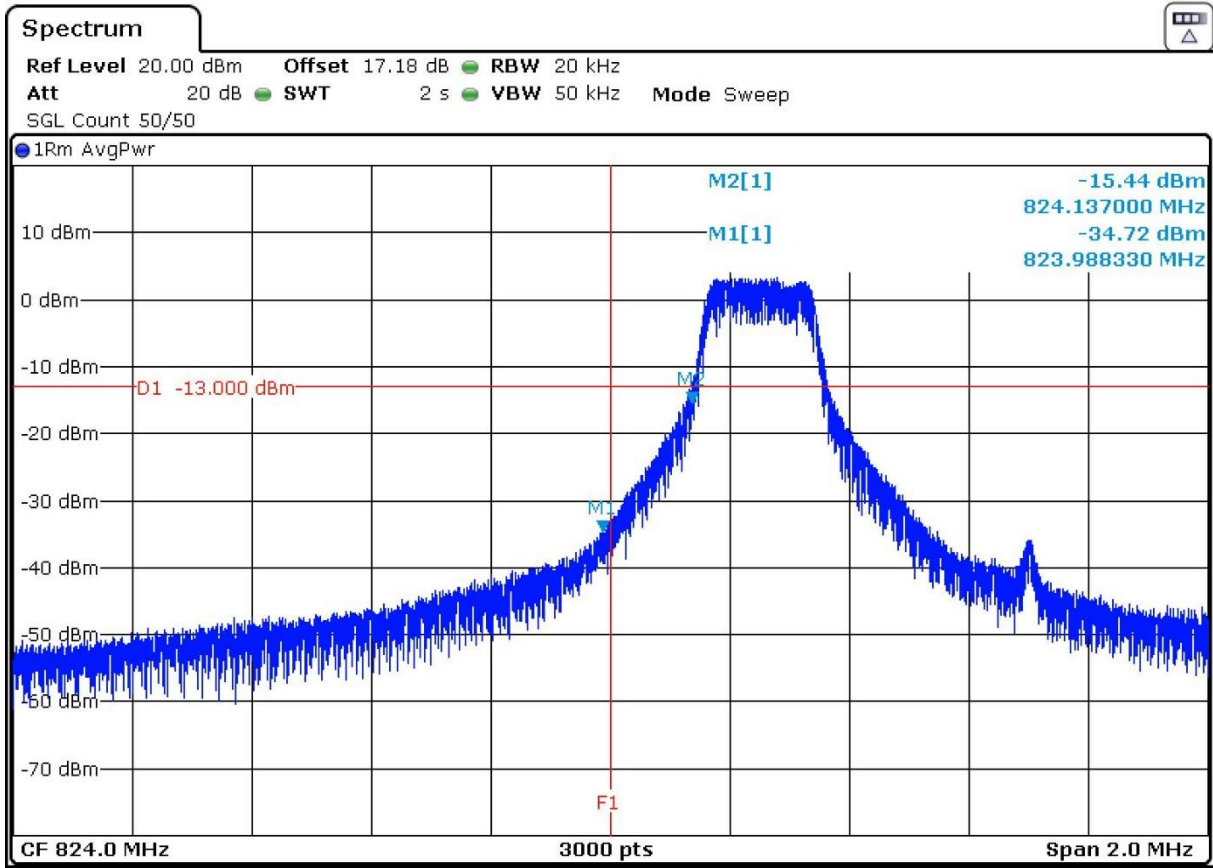

Narrow band = 1. RB = All. Offset = 0. BW = 1.4 MHz.

Low Channel:

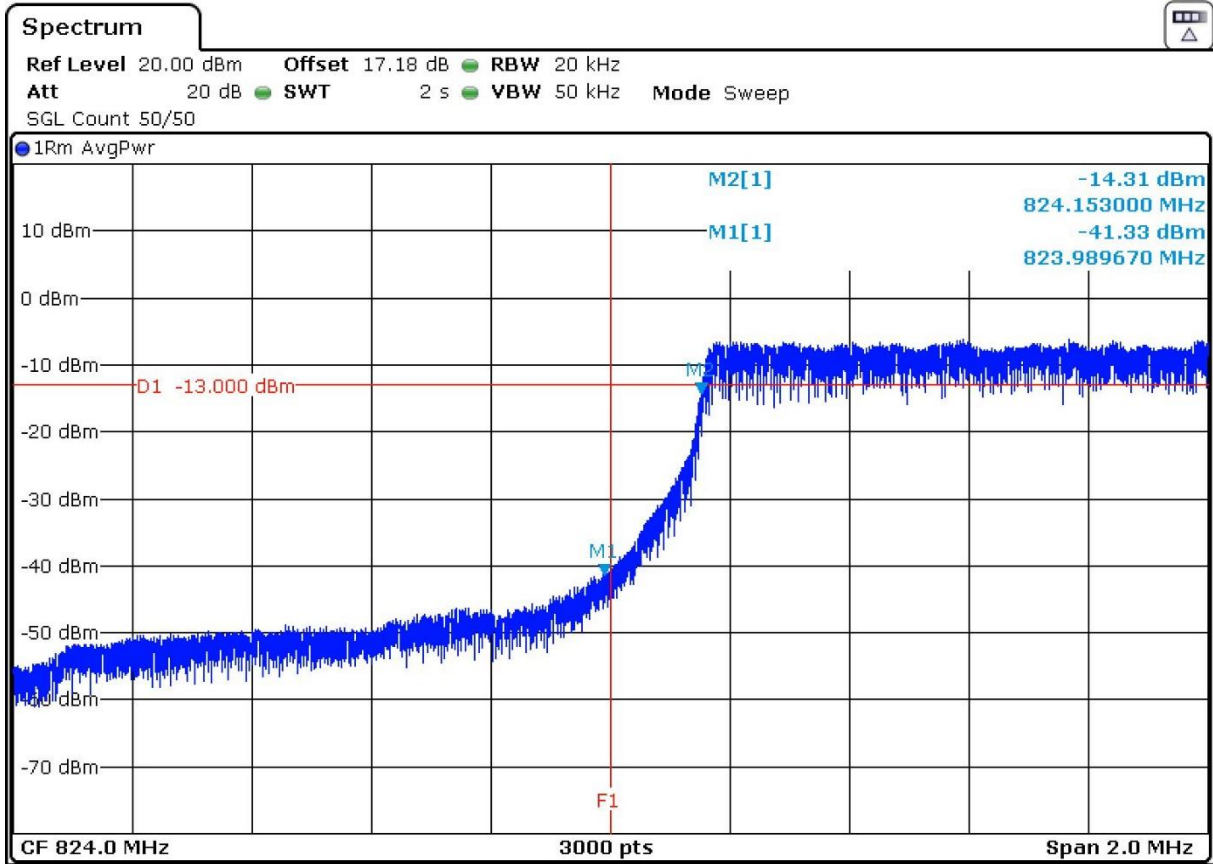

Radiated Emissions

Limits

FCC §90.691:

For any frequency removed from the EA licensee's frequency block greater than 37.5 kHz, the power of any emission shall be attenuated below the transmitter power (P) in watts by at least $43 + 10 \log_{10}(P)$ decibels or 80 decibels, whichever is the lesser attenuation, where f is the frequency removed from the center of the outer channel in the block in kilohertz and where f is greater than 37.5 kHz.

Method

The measurement was performed with the EUT inside an anechoic chamber. The spectrum was scanned from 30 MHz to at least the 10th harmonic of the highest frequency generated within the equipment.

The EUT was placed on a non-conductive stand at 3-meter distance from the measuring antenna.

Detected emissions were maximized at each frequency by rotating the EUT and adjusting the height and polarization of the measuring antenna. The maximum meter reading was recorded.

Measurement Limit:

At P_o transmitting power, the specified minimum attenuation $43 + 10 \log_{10} p$ (watts) becomes:

$$P_o \text{ (dBm)} - [43 + 10 \log (P_o \text{ in mwatts}) - 30] = -13 \text{ dBm}$$

The maximum field strength (dB μ V/m) of each detected emission at less than 20 dB respect to the limit is converted to an equivalent EIRP level (dBm) according to ANSI C63.26 with the formula:

$$\text{EIRP (dBm)} = E \text{ (dB}\mu\text{V/m)} + 20 \log(D) - 104.8;$$

where D is the measurement distance (in the far field region) in m. $D = 3 \text{ m}$

The configuration of modulation which is the worst case for conducted power was used.

Test setup

Radiated measurements below 1 GHz:

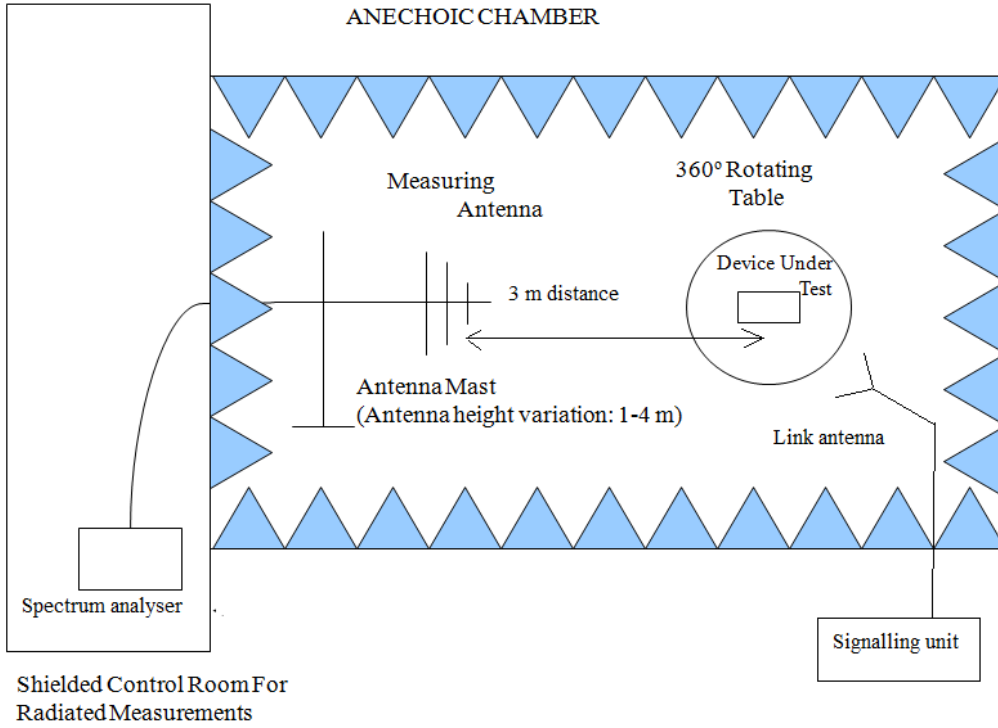

Radiated measurements above 1 GHz:

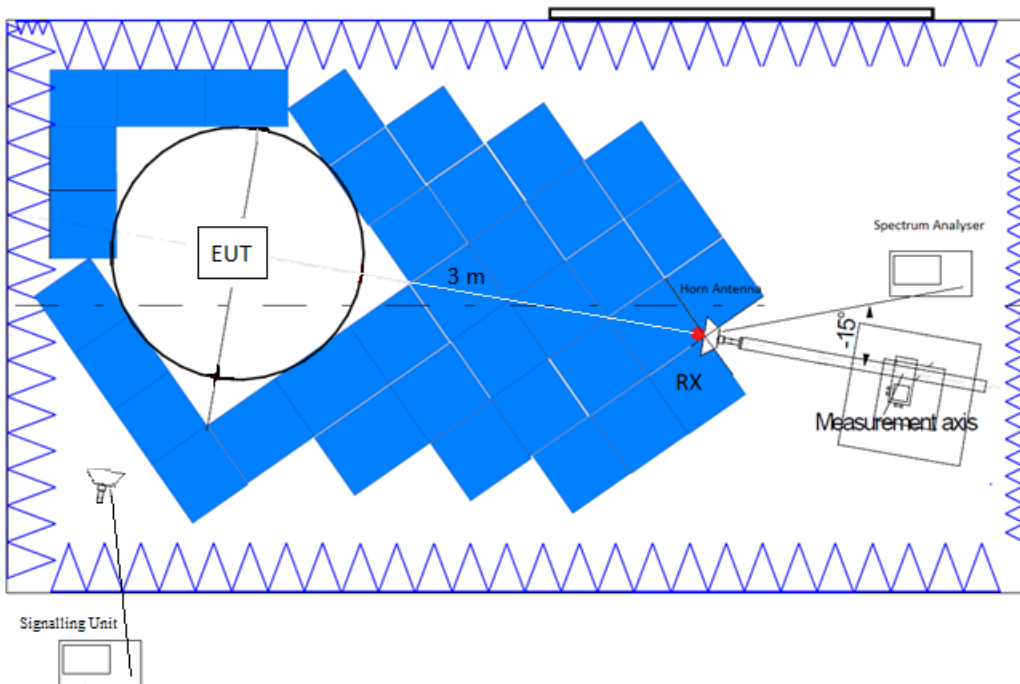

Results

LTE Band 26. Sub-band 814-824 MHz:

A preliminary scan determined the QPSK modulation, BW=1.4 MHz, RB Size=1, RB Offset=0, Narrow Band=0 as the worst case. The next results are for this worst-case configuration.

Measurements required on one frequency near top channel and one frequency near bottom channel, according to FCC § 15.31 (m).

- Low Channel:

Frequency range 30 MHz - 1 GHz:

No spurious frequencies at less than 20 dB below the limit.

Frequency range 1 - 8.5 GHz:

No spurious frequencies at less than 20 dB below the limit.

- High Channel:

Frequency range 30 MHz - 1 GHz:

No spurious frequencies at less than 20 dB below the limit.

Frequency range 1 - 8.5 GHz:

No spurious frequencies at less than 20 dB below the limit.

Measurement uncertainty (dB): < ± 5.35 for $f \geq 30$ MHz up to 1 GHz
< ± 4.32 for $f \geq 1$ GHz up to 8.5 GHz

Verdict

Pass

LTE Band 26. Cross-rule Channel 824 MHz:

A preliminary scan determined the QPSK modulation, BW=1.4 MHz, RB Size=1, RB Offset=0, Narrow Band=0 as the worst case. The next results are for this worst-case configuration.

- Single Channel (Cross-rule Channel 824 MHz):

Frequency range 30 MHz - 1 GHz:

No spurious frequencies at less than 20 dB below the limit.

Frequency range 1 - 8.5 GHz:

No spurious frequencies at less than 20 dB below the limit.

Measurement uncertainty (dB): < ± 5.35 for $f \geq 30$ MHz up to 1 GHz
< ± 4.32 for $f \geq 1$ GHz up to 8.5 GHz

Verdict

Pass

Attachments

LTE Band 26. Sub-band 814-824 MHz:

FREQUENCY RANGE 30 MHz - 1 GHz

- Low Channel:

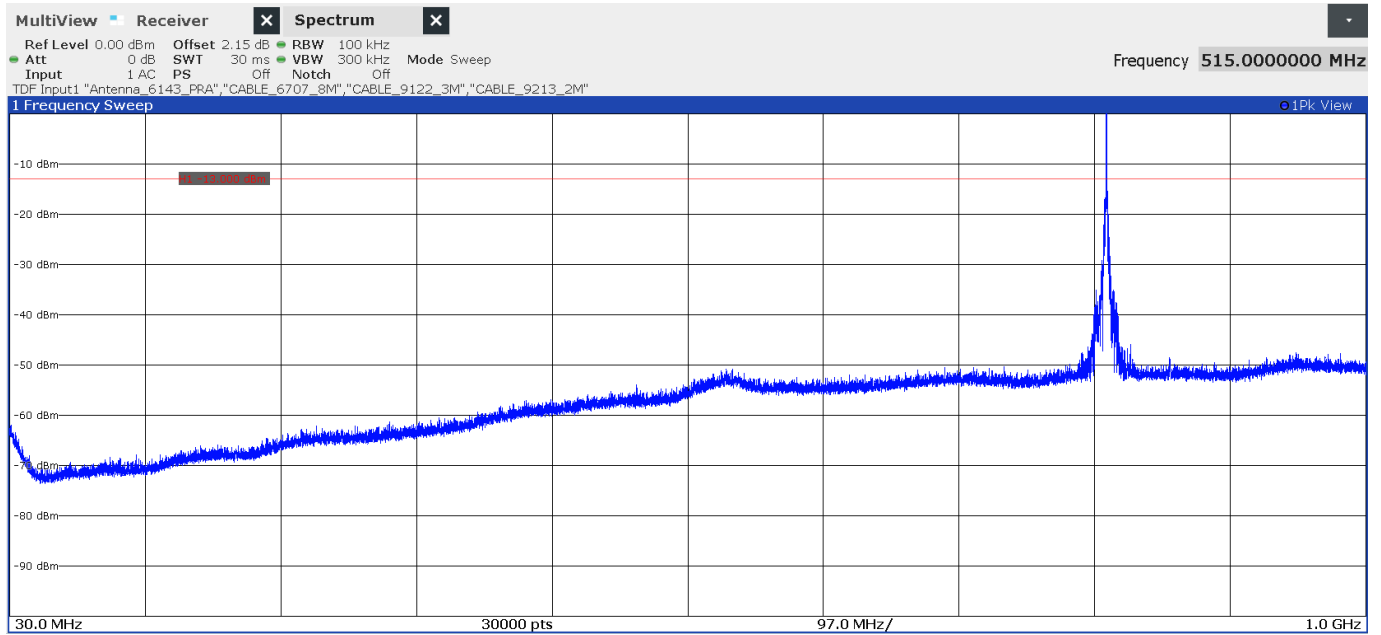

The peak above the limit is the carrier frequency:
LTE Band 26, 814.7 MHz

- High Channel:

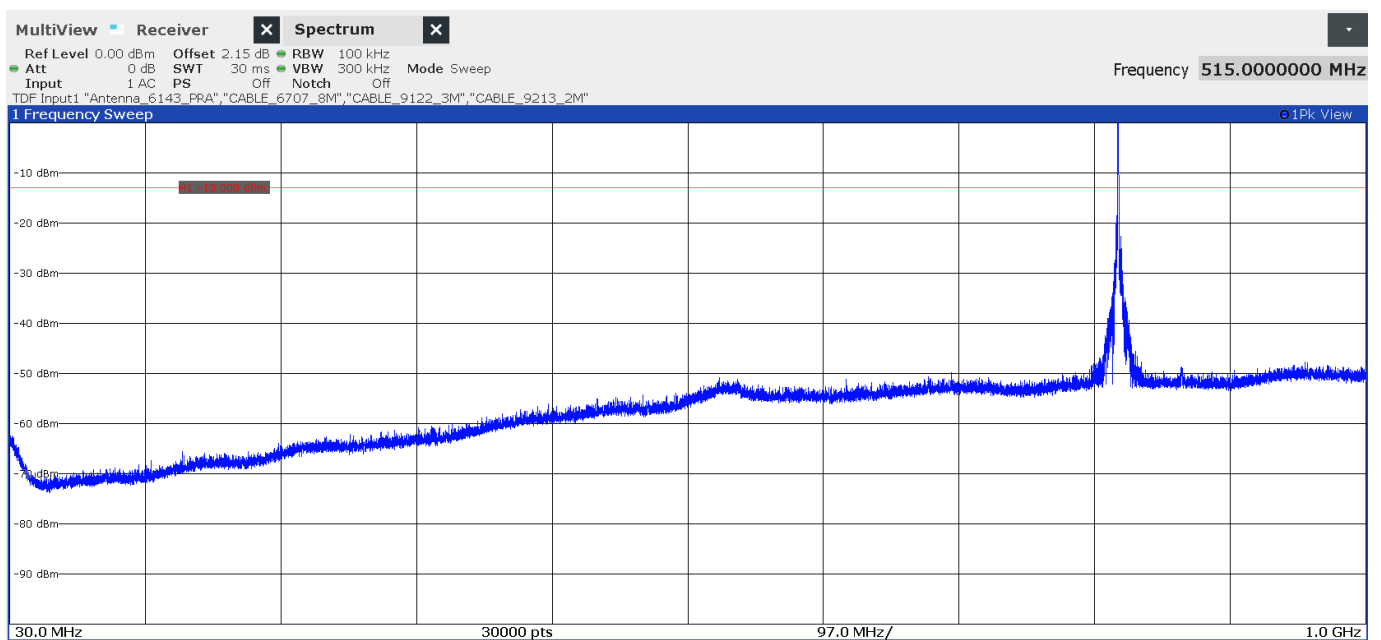

The peak above the limit is the carrier frequency:
LTE Band 26, 819.3 MHz

FREQUENCY RANGE 1 - 8.5 GHz

- Low Channel:

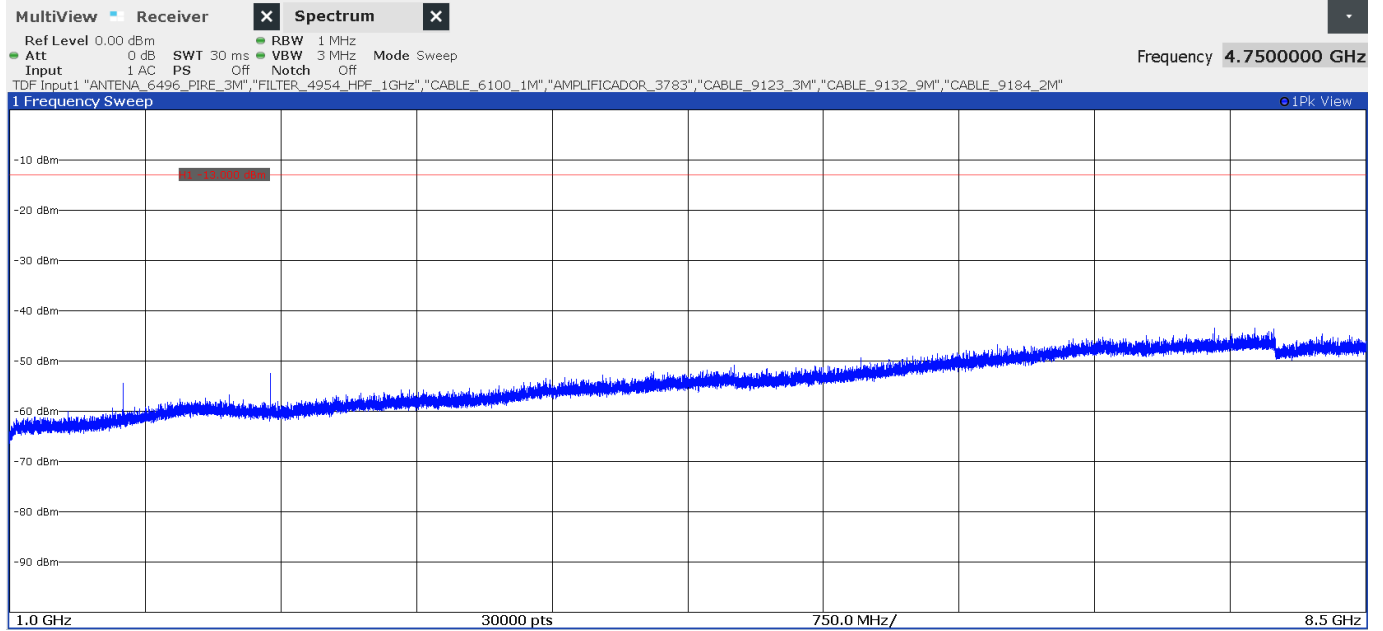

- High Channel:

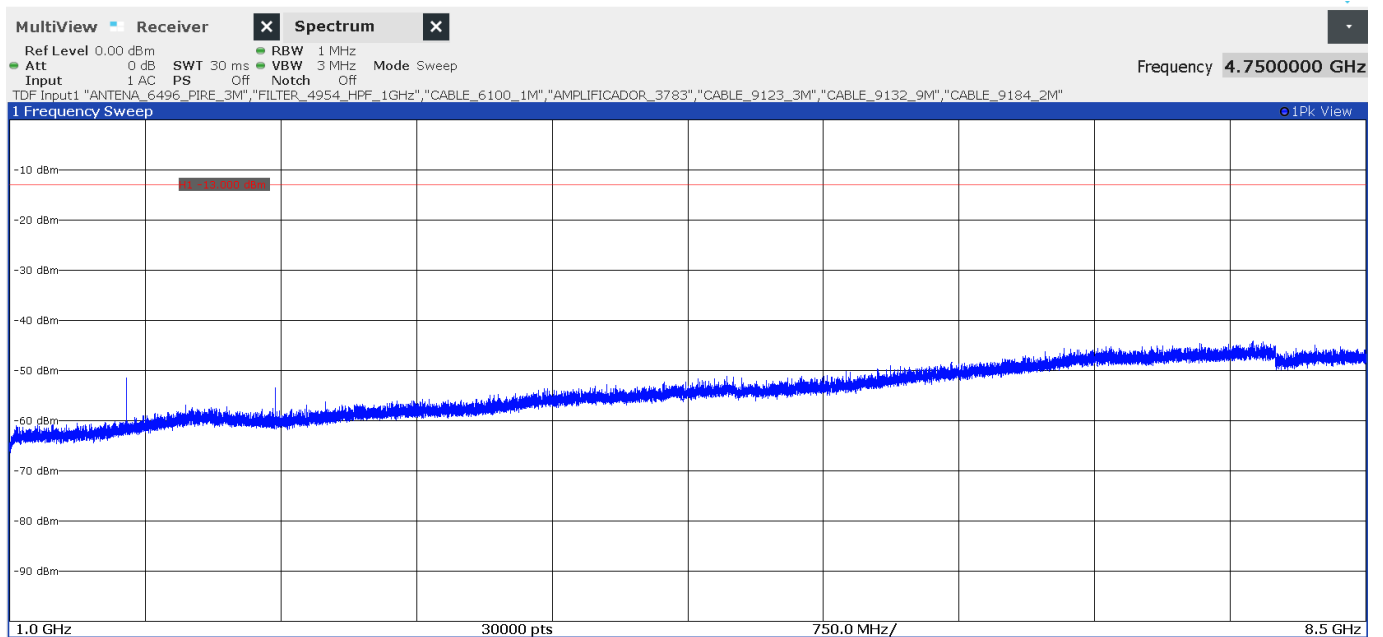

LTE Band 26. Cross-rule Channel 824 MHz:

FREQUENCY RANGE 30 MHz - 1 GHz

- Cross-rule Channel:

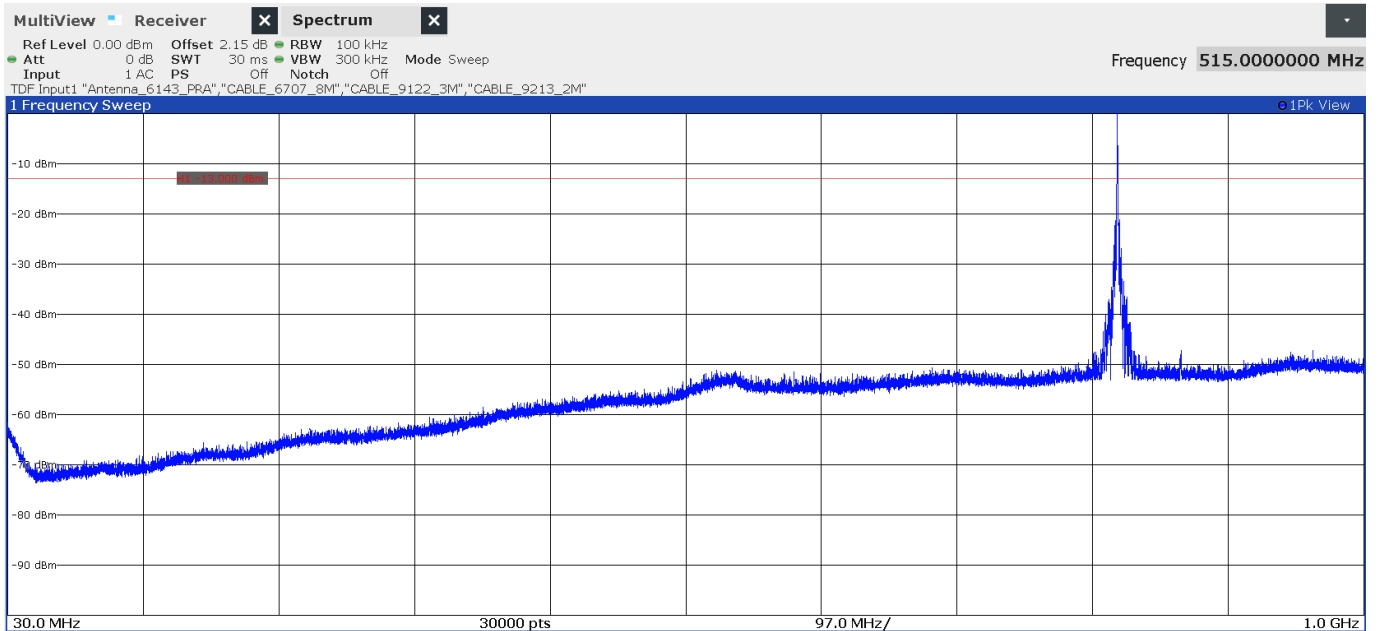

The peak above the limit is the carrier frequency:
LTE Band 26, 824 MHz

FREQUENCY RANGE 1 - 8.5 GHz

- Cross-rule Channel:

