



Bestway®

Para la instrucción en español,
visite bestwaycorp.com/support

SaluSpa™

Owner's Manual

Visit Bestway YouTube channel 

**FOR INSTRUCTION VIDEOS
PLEASE VISIT**

bestwaycorp.com/support



CONTENTS

1. WarningP2	4. Maintenance P8
2. InstallationP5	Filter Cartridge Maintenance
Selected Location	Water Maintenance
GFCI Test	Air-Valve Adjustment
Assembly	Draining the Spa
3. Pump OperationP7	Cleaning the Spa
Control Panel	Deflation
Alarms	Spa Repair
	5. Troubleshooting P10

WARNING

IMPORTANT SAFETY INSTRUCTIONS

When using this electrical equipment, basic safety precautions should always be followed, including the following:

READ AND FOLLOW ALL INSTRUCTIONS.

WARNING – To reduce the risk of injury, do not permit children to use this product unless they are closely supervised at all times.

A wire connector is provided on this unit to connect a minimum 8 AWG (8.37 mm²) solid copper conductor between this unit and any metal equipment, metal enclosures of electrical equipment, metal water pipe, or conduit within 5 feet (1.5 m) of the unit.

DANGER – Risk of injury.

- a) Replace damaged cord immediately.
- b) Do not bury cord.
- c) Connect to a grounded, grounding type receptacle only.

WARNING – This product is provided with a ground-fault circuit-interrupter integrated with the power plug at the end of the cord. The GFCI must be tested before each use.

With the product operating, push the test button on the GFCI and the product should not operate. Push the reset button on the GFCI and the product should now operate normally. When the product fails to operate in this manner, there is a ground current flowing indicating the possibility of an electrical shock. Disconnect the power until the fault has been identified and corrected.

DANGER – Risk of Accidental Drowning. Extreme caution must be exercised to prevent unauthorized access by children. To avoid accidents, ensure that children cannot use this spa unless they are supervised at all times.

DANGER – Risk of Injury. The suction fittings in this spa are sized to match the specific water flow created by the pump. Should the need arise to replace the suction fittings or the pump, be sure that the flow rates are compatible. Never operate spa if the suction fittings are broken or missing. Never replace a suction fitting with one

rated less than the flow rate marked on the original suction fitting.

DANGER – Risk of Electric Shock. Install at least 5 feet (1.5 m) from all metal surfaces. As an alternative, a spa may be installed within 5 feet of metal surfaces if each metal surface is permanently connected by a minimum 8 AWG (8.37 mm²) solid copper conductor to the wire connector on the terminal box that is provided for this purpose.

DANGER – Risk of Electric Shock. Do not permit any electric appliance, such as a light, telephone, radio, or television, within 5 feet (1.5 m) of a spa.

WARNING – To reduce the risk of injury:

- a) The water in a spa should never exceed 104°F (40°C). Water temperatures between 100°F (38°C) and 104°F (40°C) are considered safe for a healthy adult. Lower water temperatures are recommended for young children and when spa use exceeds 10 minutes.
- b) Since excessive water temperatures have a high potential for causing fetal damage during the early months of pregnancy, pregnant or possibly pregnant women should limit spa water temperatures to 100°F (38°C).
- c) Before entering a spa, the user should measure the water temperature with an accurate thermometer since the tolerance of water temperature-regulating devices varies.
- d) The use of alcohol, drugs, or medication before or during spa use may lead to unconsciousness with the possibility of drowning.
- e) Obese persons and persons with a history of heart disease, low or high blood pressure, circulatory system problems, or diabetes should consult a physician before using a spa.
- f) Persons using medication should consult a physician before using a spa since some medication may induce drowsiness while other medication may affect heart rate, blood pressure, and circulation.

WARNING: TO AVOID ELECTRIC SHOCK, DO NOT USE THE SPA WHEN IT IS RAINING.

WARNING: Water attracts children; Always attach a spa cover after each use.

WARNING: TO REDUCE THE RISK OF INJURY: Never add water that is higher than 104°F (40°C) into the Spa.

CONSULT YOUR PHYSICIAN FOR RECOMMENDATIONS.

CAUTION: The spa should not be setup or left out in temperatures lower than 40°F (4°C).

CAUTION: Do not use the spa alone.

CAUTION: Always enter and exit the spa slowly and cautiously. Wet surfaces are slippery.

CAUTION: To avoid damage to the pump, the spa must never be operated unless the spa is filled with water.

CAUTION: Immediately leave spa if the user feels uncomfortable or sleepy.

NOTE: Please examine equipment before use. Notify Bestway® at the customer service address listed on this manual for any damaged or missing parts at the time of purchase. Verify that the equipment components represent the model that you had intended to purchase.

This device complies with part 15 of the FCC Rules. Operation is subject to the following two conditions: (1) This device may not cause harmful interference, and (2) this device must accept any interference received, including interference that may cause undesired operation.

This device contains licence-exempt transmitter(s)/receiver(s) that comply with Innovation, Science and Economic Development Canada's licence-exempt RSS(s). Operation is subject to the following two conditions:

(1) This device may not cause interference.

(2) This device must accept any interference, including interference that may cause undesired operation of the device.

Any changes or modifications to this unit not expressly approved by the party responsible for compliance could void the user's authority to operate the equipment.

NOTE: This equipment has been tested and found to comply with the limits for a Class B digital device, pursuant to part 15 of the FCC Rules. These limits are designed to provide reasonable protection against harmful interference in a residential installation. This equipment generates, uses and can radiate radio frequency energy and, if not installed and used in accordance with the instructions, may cause harmful interference to radio communications. However, there is no guarantee that interference will not occur in a particular installation. If this equipment does cause harmful interference to radio or television reception, which can be determined by turning the equipment off and on, the user is encouraged to try to correct the interference by one or more of the following measures:

- Reorient or relocate the receiving antenna.
- Increase the separation between the equipment and receiver.
- Connect the equipment into an outlet on a circuit different from that to which the receiver is connected.
- Consult the dealer or an experienced radio/TV technician for help.

Changes or modifications not expressly approved by the party responsible for compliance could void the user's authority to operate the equipment.

To satisfy FCC / IC RF exposure requirements, a separation distance of 20 cm or more should be maintained between the antenna of this device and persons during device operation.

To ensure compliance, operations at closer than this distance is not recommended. Limited by local law regulations, version for North America does not have region selection option.

SAVE THESE INSTRUCTIONS

ASSEMBLY: THE PROVIDED WARNING LABEL



WARNING

REDUCE THE RISK OF ELECTROCUTION

1. NEVER PLACE AN ELECTRIC APPLIANCE WITHIN 5 FEET OF SPA.

REDUCE THE RISK OF CHILD DROWNING

1. SUPERVISE CHILDREN AT ALL TIMES.
2. ATTACH SPA COVER AFTER EACH USE.

REDUCE THE RISK OF OVERHEATING

1. CHECK WITH A DOCTOR BEFORE USE IF PREGNANT, DIABETIC, IN POOR HEALTH, OR UNDER MEDICAL CARE.
2. EXIT IMMEDIATELY IF UNCOMFORTABLE, DIZZY, OR SLEEPY. SPA HEAT CAN CAUSE HYPERTHERMIA AND UNCONSCIOUSNESS.
3. SPA HEAT IN CONJUNCTION WITH ALCOHOL, DRUGS, OR MEDICATION CAN CAUSE UNCONSCIOUSNESS.

WHEN PREGNANT, SOAKING IN HOT WATER FOR LONG PERIODS CAN HARM YOUR FETUS. MEASURE WATER TEMPERATURE BEFORE ENTERING.

1. DO NOT ENTER SPA IF WATER IS HOTTER THAN 100°F (38°C)
2. DO NOT STAY IN SPA FOR LONGER THAN 10 MINUTES.

NOTE: The warning label must be posted near your spa in a readable position during using your spa.

1. Take out the warning label from the accessory kit.
2. Carefully peel the warning label.
3. Affix the warning label.

To order the warning label, please contact your local Bestway After Sales Service.

IMPORTANT !

To reach 104°F (40°C), the heating duration required is base on the starting water temperature and ambient temperature, the data below is purely for reference. To display the current water temperature, run the filter system for at least a minute.

Ambient Temperature	Water Temperature	Set Temperature	Heating Duration
50°F	50°F	104°F	32 h
59°F	59°F	104°F	26 h
68°F	68°F	104°F	20 h
77°F	77°F	104°F	14 h
86°F	86°F	104°F	9 h

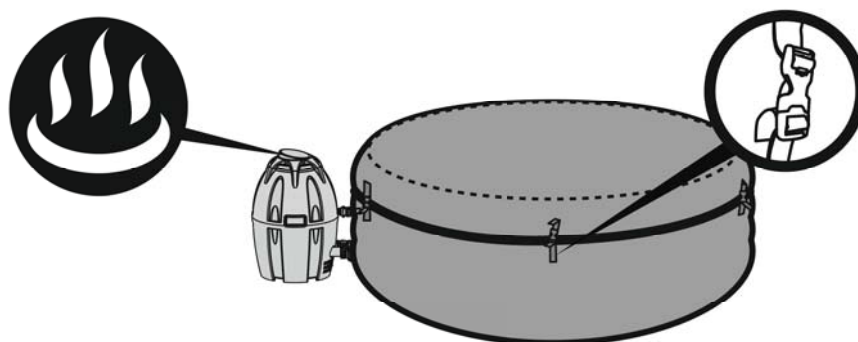

Be sure to cover the spa with the spa cover whenever the heating function is activated. Leaving the spa uncovered will increase the heating duration required.

Please do not use the spa when ambient temperature is lower than 39°F.

Power Rate	Massage Tube Power	Heat Element Power	Water Pump Power
110-120V AC, 12A at 20°C	6.5A	11.3A at 20°C	0.7A

For more information of APP matching, please go to Bestwaycorp.com to find the instruction. Search and download the "Bestway" from google play or apple store.

INSTALLATION

Selected Location

IMPORTANT: Because of the combined weight of the SaluSpa, water, and users, it is extremely important that the base where the SaluSpa is installed is smooth, flat, level and capable of uniformly supporting the weight for the entire time the SaluSpa is installed (not on the carpet or other similar material). If the SaluSpa is placed on a surface, which does not meet these requirements, any damage caused by improper support is not covered under the manufacturer's warranty. It is the responsibility of the SaluSpa owner to assure the integrity of the site at all times.

1. Indoor Installation:

Be aware of special requirements if you install the spa indoors.

- Humidity is a natural side effect with SaluSpa installation. Determine the effects of moisture on exposed wood, paper, etc. in the proposed location. To minimize these effects, it is best to provide plenty of ventilation to the selected area. An architect can help determine if more ventilation is needed.

2. Outdoor Installation:

- During filling, draining or when in use, water may spill out of the spa. Therefore the SaluSpa should be installed near a floor drain.
- Do not leave the spa's surface exposed to direct sunlight for long periods of time.

MILAN AirJet Plus (#54185E)



2-3°F/h (1.0-1.5°C/h)



320 gal/h (1,211 L/h)



4-6 77" x 28"
(1.96m x 71cm)



0.08Bar (1.2PSI)

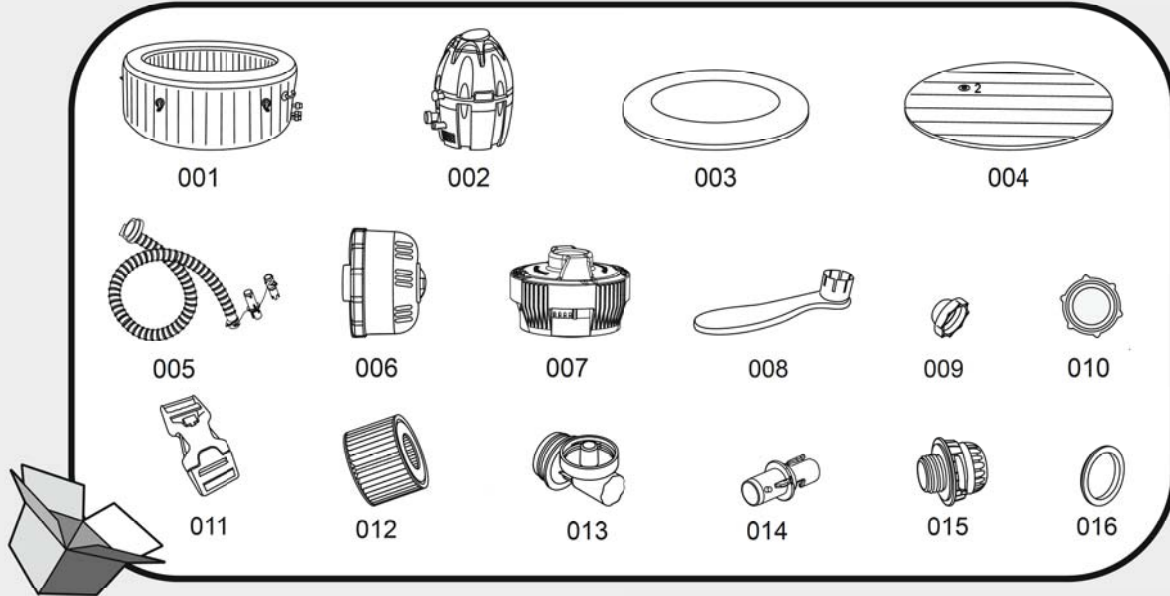

001	P04603	1
002	P04662	1
003	P04618	1
004	P04470	1
005	P6930ASS18	1
006	P04674	2
007	P03821	1
008	F6H189ASS16	1
009	P6575ASS16	3
010	P00217	1
011	F6414ASS16	6
012	58323	2
013	P61726ASS18	1
014	P61725ASS18	1
015	P00260	1
016	P6609ASS16	1

GFCI Test

IMPORTANT: RISK OF ELECTRIC SHOCK. THE GFCI MUST BE TESTED BEFORE TURNING ON THE PUMP EACH TIME.

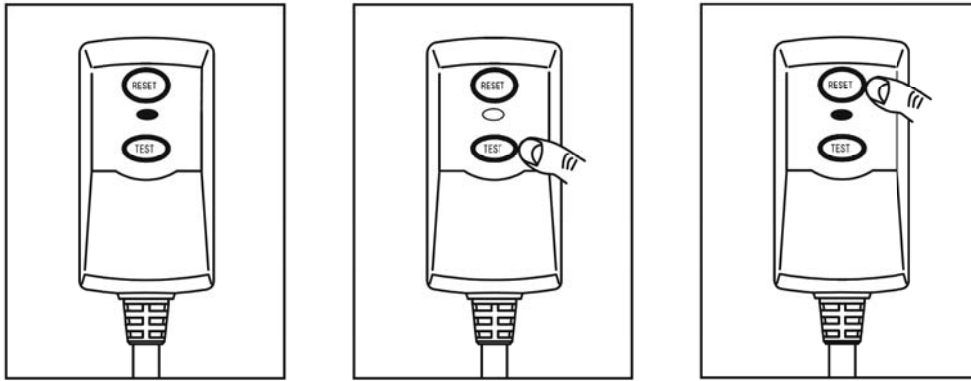

1. Plug the GFCI into a power outlet, the indicator turns red.
2. Press the test button, the indicator turns off.
3. Press the reset button again, the indicator turns red and the spa is ready for use.

WARNING: The GFCI plug must be tested before each use to avoid risk of electric shock.

WARNING: Before inserting plug into a power outlet, make sure the current rate of the power outlet is suitable for the pump.

WARNING: Do not use the pump if this test fails and contact our Aftersales Service.

NOTE: When inflating, you will notice that air will be expelled from the area where the air hose connects to the pump, this is normal for technique requirements.

NOTE: Do not use an air compressor to inflate the pool.

NOTE: Do not drag the pool on rough ground as this may cause damage to the pool liner.

NOTE: Inflation time for reference only.

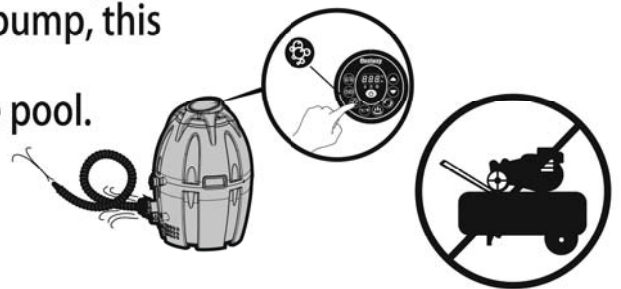

Air Valve Check (for spa with quick inflation/deflation valve)

Always check the air valve carefully before inflation to ensure there is not an air leak. If the air valve is loose, use the provided wrench to fasten the air valve following these steps: With one hand, hold the backside of the air valve from the inner side of the spa wall and turn the wrench clockwise.

NOTE:

1. Do not over tighten.
2. Do not adjust the air valve connector when the spa is in use.

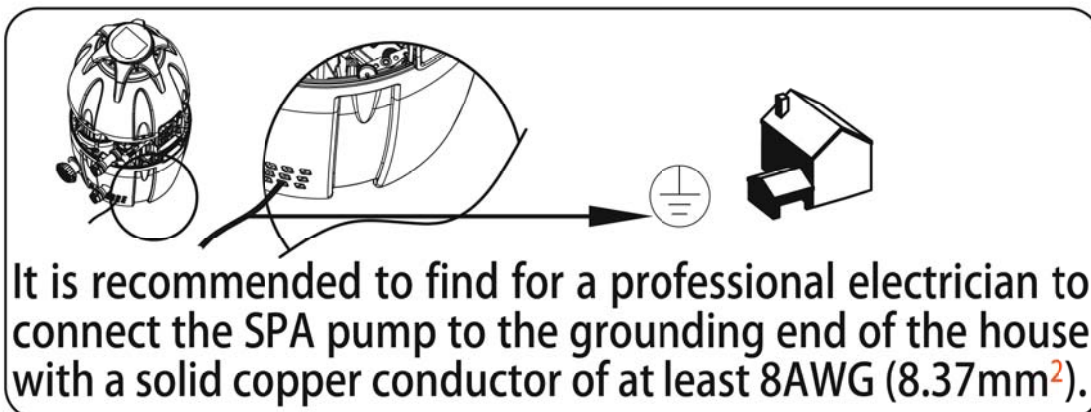
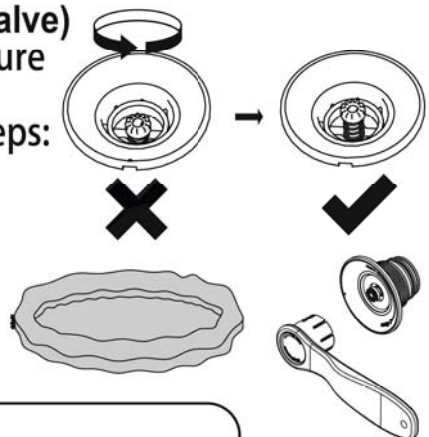

Assembly

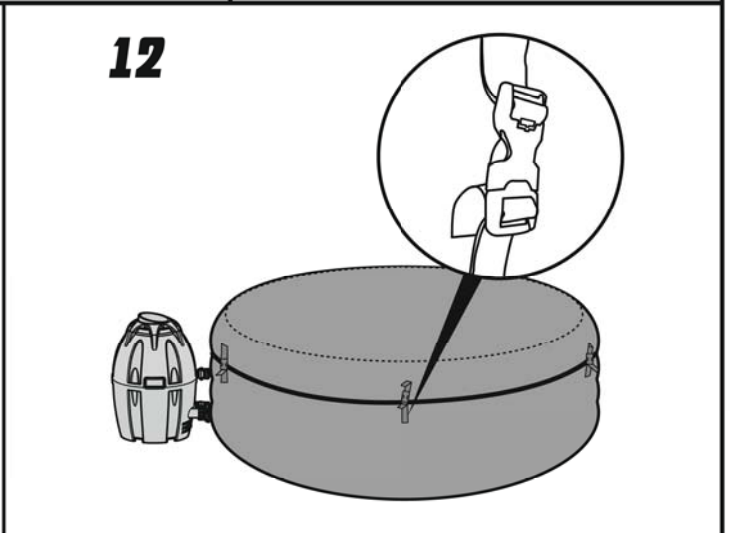
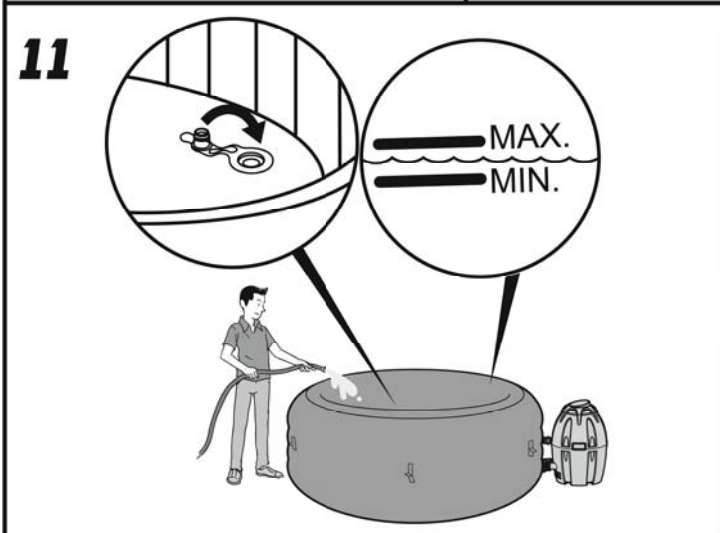
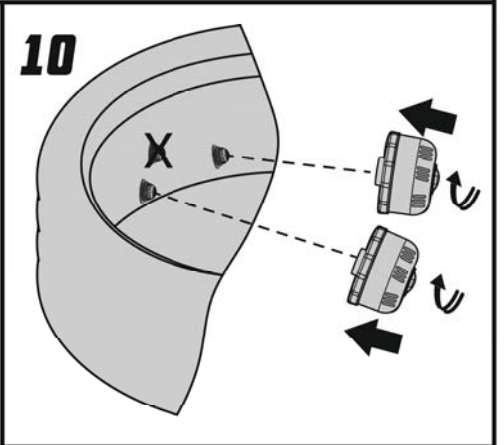
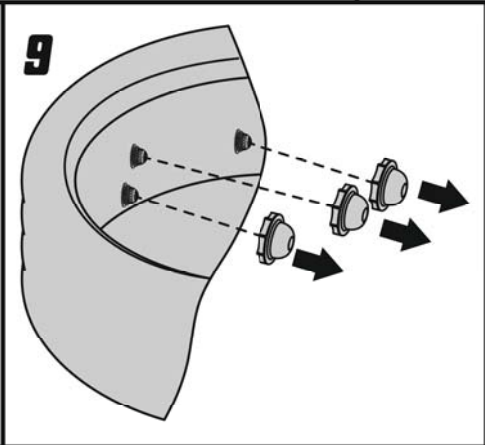
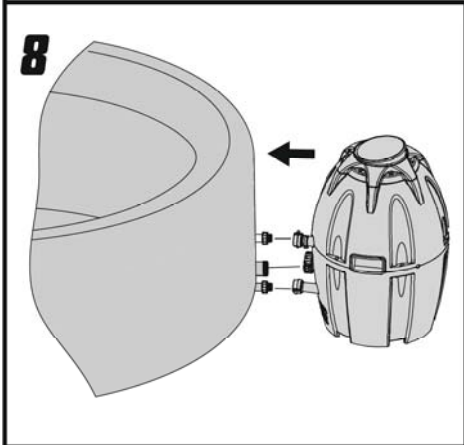
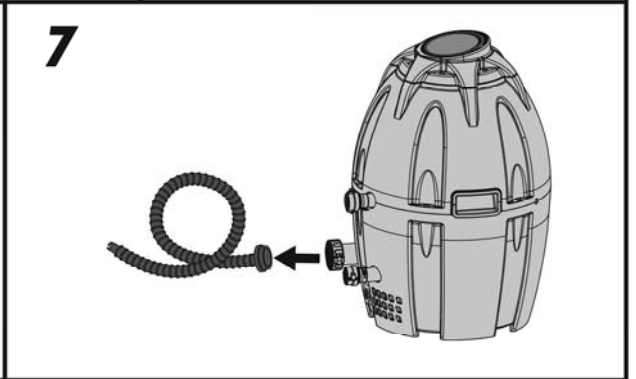
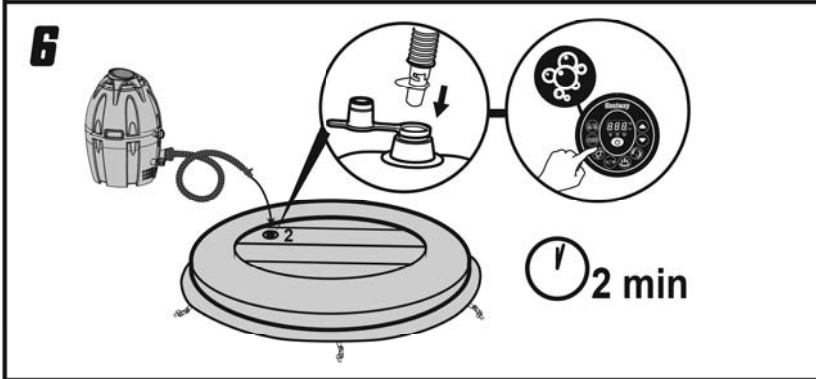
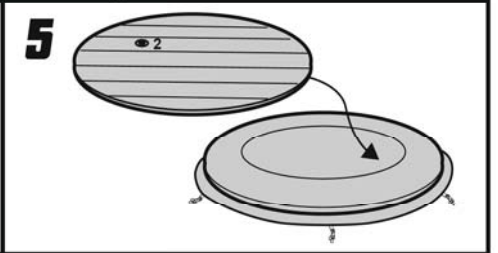
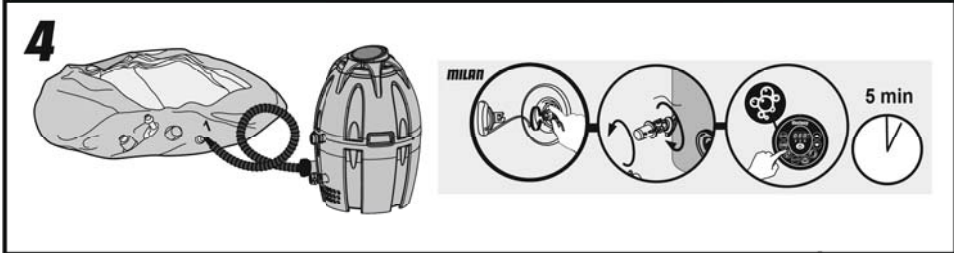
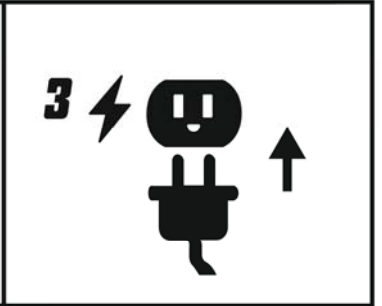
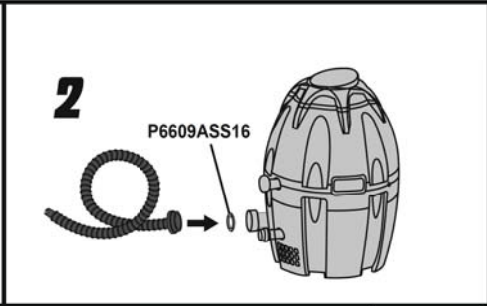
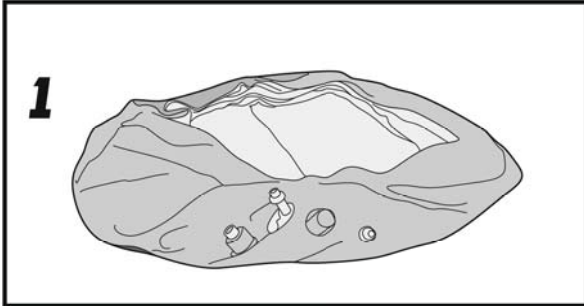

Hyperthermia occurs when the internal temperature of the body reaches a level several degrees above the normal body temperature of 37°C (98.6°F). The symptoms of hyperthermia include an increase in the internal temperature of the body, dizziness, lethargy, drowsiness, and fainting. The effects of hyperthermia include failure to perceive heat; failure to recognize the need to exit spa or hot tub; unawareness of impending hazard; fetal damage in pregnant women; physical inability to exit the spa or hot tub; and unconsciousness resulting in the danger of drowning.



WARNING – The use of alcohol, drugs, or medication can greatly increase the risk of fatal hyperthermia.

Lock/Unlock Button



The pump has a 5-minute auto-lock. The LED light will dim out when the pump is locked (no function is activated). To lock or unlock the pump, place a finger over the lock/unlock button for 3 seconds.

Power-Saving Timer Button



This is a newly added function, designed to help avoid wasting power by setting the time and duration of the heating cycle for the spa. This way, you can enjoy your spa at the time you desire, without needing to leave the heater on at all times.

STEP 1: Set the heating duration

1. Press the button unit the LED starts to flash.
2. Press the or button to adjust the heating duration (From 1-48 hours).
3. Press the button again to confirm the heating duration.

STEP 2: Set the number of hours FROM NOW when the heater will activate

1. After setting the heating duration, the LED starts to flash.
2. Press the or button to adjust the hours until time of activation (From 0-99 hours).
3. Press button again or simply touch nothing for 10 seconds to confirm the setting. The LED will light steadily, and the countdown to heater activation will begin.

To modify the timer settings: Press the button and use the or button to adjust. Cancel the setting: Press the button for 2 seconds.

NOTE: After setting, the screen flashes the current temperature and time alternately.

NOTE: Timer adjustment (amount of time with the heater ON) may be set from 1-4 hours; Reservation time adjustment (the number of hours FROM NOW when the heater will begin to function) may be set from 0-99 hours. If the timer is set at 0 hour, the heating system will activate immediately.

Note that the timer is one time per use - the user sets the duration of the heating cycle, and how many hours from now the heating cycle begins. The timer does NOT repeat until reset.

Massage System Button



Use this button to activate the massage system, which has a 30-minute auto-shutoff feature. The light above the Massage System Button displays red when activated.

IMPORTANT: Do not run the Massage system when the cover is attached. Air can accumulate inside the spa and cause irreparable damage and bodily harm.

NOTE: Heat and massage system work together to create a warm massage experience.



Indicator light show

Indicator light flash slowly

Indicator light on

Indicator light flash quickly

Indicator light off

The state of the pump

Waiting connect the Wi-Fi

Connected the Wi-Fi

Lost Wi-Fi simple signal

Light damaged & Wi-Fi module is damaged

Note: This button has the led light that show the status of the connect with the wifi

Celsius/Fahrenheit Toggle



The temperature can be displayed in either Fahrenheit or Celsius.

If you want to connect to another mobile phone, please turn off the power button, Then press the Celsius/Fahrenheit buttons for 3 seconds.

This button has wifi configuration function. For more information, please refer to wifi operation instructions



Heat Button

Use this button to activate the heating system. When the light above the heat button is red, the heating system is activated. When the light is green, the water is at the set temperature and the heating system is at rest.

NOTE: If the heating system is activated the filtration system will automatically start.

NOTE: After turning off the heating system the filtration system will continue to operate.

Water Filter Button



This button turns the filter pump on and off. The light above the Water Filter Button displays red when activated.



Temperature Adjustment Buttons

Pressing the Temperature Increase or Decrease buttons will cause the LED to flash. When it is flashing you can adjust to the desired temperature setting. If you hold these buttons down the values will rapidly increase or decrease. The new and desired temperature setting will remain on the LED display for 3 seconds to confirm the new value.

NOTE: The default temperature is 35°C (95°F).

NOTE: Temperature adjustment ranges from 20°C (68°F) to 40°C (104°F).



On/Off Button

Press this button for 2 seconds to activate the control panel buttons and the light turns to green. Press this button for 2 seconds to turn off all currently activated functions.



Power-Saving Timer LED

This LED flashing means you are setting the heating duration. The light will be on when the heating function starts to work. This LED flashing means you are setting the number of hours FROM NOW when the heater will activate. When the light is on, the Power-Saving Timer function is set.



After 72 hours of filtration (without using the power saving timer function), the pump will hibernate and flash "End" with the current water temperature. When the pump is hibernating both the heating and water filter functions are disabled. To re-activate the pump press lock/unlock button for 3 seconds.









NOTE: The water heat rate may change in the conditions below:

- When the outdoor temperature is below 15°C (59°F).

If the cover is not in position when the heating function is activated.

NOTE: To display the current water temperature, run the filter system for at least a minute. The water temperature as tested by an external thermometer may vary from the temperature as displayed on the spa panel by as much as approximately 2°C.

Alarms

	Causes	Reasons	Solutions
	The water flow sensors work without pressing the filter or heat button.	<ol style="list-style-type: none"> 1. The water flow sensor flags didn't fall back into the correct position. 2. The water flow sensors are broken. 	<ol style="list-style-type: none"> 1. Unplug the pump, strike the side of the pump firmly (but not violently), and plug it back in. 2. To get assistance visit our website www.bestwaycorp.com support section.
	After starting or during the functions of filtering or/and heating, the water flow sensors do not detect water flow.	<ol style="list-style-type: none"> 1. You forgot to remove the 3 stopper caps from inside the pool. 2. Filter cartridges are dirty. 3. Activate the filter or heat system and put your hand in front of the outlet pipe inside the pool to check if you can feel water flowing out. <ol style="list-style-type: none"> a. If no water flows out the water pump is broken. b. Water flows out but the alarm  than the water flow sensors are broken. 	<ol style="list-style-type: none"> 1. Remove the two stopper caps before starting the heating system. Refer to the Assembly section in the User's Manual. 2. Remove the filter set from inside the pool and push the filter or heat button. If no alarm appears, clean or change the filter cartridges and re-install the filter set inside the pool. 3. To get assistance visit our website www.bestwaycorp.com support section.
	The pump's thermometer reads the water temperature below 4°C (40°F).	<ol style="list-style-type: none"> 1. The water temperature is lower than 4°C (40°F). 2. If the water temperature is higher than 7°C (44.6°F), the pump's thermometer is broken. 	<ol style="list-style-type: none"> 1. The spa is not designed to operate with water temperatures lower than 4°C (40°F). Unplug the pump and only re-start the pump when the water temperature reaches 6°C (43°F). 2. To get assistance visit our website www.bestwaycorp.com support section.
	The pump's thermometer reads the water temperature over 48°C (119°F).	<ol style="list-style-type: none"> 1. The water temperature is over 48°C (119°F). 2. If the water temperature is lower than 45°C (113°F), the pump's thermometer is broken. 	<ol style="list-style-type: none"> 1. The spa is not designed to operate with water temperatures greater than 40°C (104°F). Unplug the pump and only re-start the pump when the water temperature reaches 38°C (100°F) or lower. 2. To get assistance visit our website www.bestwaycorp.com support section.
	The pump's thermometer connections have issues.	<ol style="list-style-type: none"> 1. The pump's thermometer connectors don't work properly. 2. The pump's thermometer is broken. 	To get assistance visit our website www.bestwaycorp.com support section.
	The thermal cut-out cut off.	<ol style="list-style-type: none"> 1. The ambient temperature is over 50°C (122°F) or the pump is directly under the sunshine. 2. The thermal cut-out is broken. 	<ol style="list-style-type: none"> 1. Unplug the pump, and put the pump in a dry, cool place. Only re-start the pump when the water temperature reaches 34°C (93.2°F) or lower. 2. To get assistance visit our website www.bestwaycorp.com support section.
	Wifi Module Connection Failed.	Wifi module is damaged	To get assistance visit our website www.bestwaycorp.com support section. NOTE: Press any button to remove alarm and continue to use the spa.

Maintenance

NOTE: Your spa will require additional air to be added from time to time. Changes in temperature from day to night will change the pressure in the spa and may cause a certain amount of deflation. Please follow the Assembly instructions and drain the spa before inflating to the accurate pressure needed.

CAUTION: YOU MUST ENSURE THE PUMP IS UNPLUGGED BEFORE BEGINNING SPA MAINTENANCE TO AVOID RISK OF INJURY OR DEATH.

Filter Cartridge Maintenance

NOTE: To ensure your spa water stays clean, check and clean your filter cartridges every day follow the steps below.

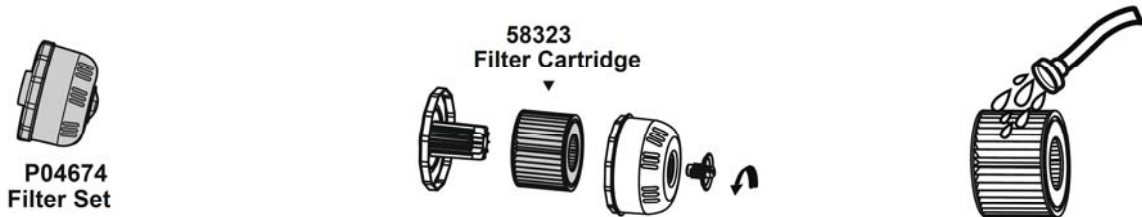

NOTE: We recommend changing your filter cartridges every week or, if the filter cartridges remain soiled and discolored, they should be replaced.

Water Maintenance

Keeping your spa water clean and chemically balanced is necessary. Simply cleaning the filter cartridge is not enough for proper maintenance, we recommend you use pool chemicals to maintain water chemistry and chlorine or bromine tablets (do not use granules) with the chemical dispenser.

NOTE: We recommend you take a shower before using your SaluSpa, as cosmetic products, lotions, and other residues on the skin can quickly degrade water quality. To use the chemical dispenser, please follow the below instruction.

Using chemical tablets (not included):

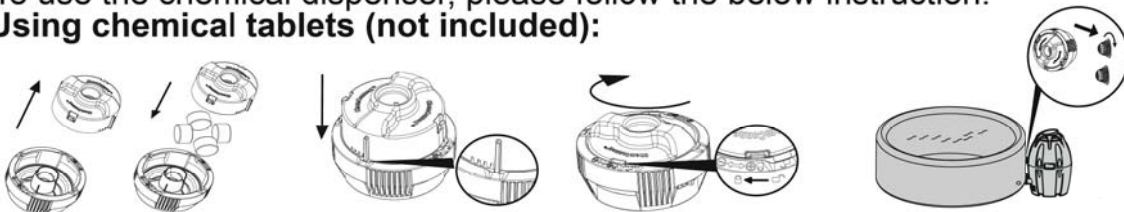

Using chemical liquid (not included):



NOTE: Remove the chemical dispenser from spa when the spa is in use.

IMPORTANT: After performing chemical maintenance and before using the spa, use a test kit (not included) to test the water chemistry. We recommend maintaining your water as below table.

pH	Total Alkalinity	Free Chlorine
7.4-7.6	80-120ppm	2-4ppm

NOTE: Damage resulting from chemical imbalance is not covered by the warranty. Pool chemicals are potentially toxic and should be handled with care. There are serious health risks from chemical vapors and the incorrect labeling and storage of chemical containers. Please consult your local pool supply retailer for more information about chemical maintenance. Pay close attention to the chemical manufacturer's instructions. Spa damage resulting from misuse of chemicals and mismanagement of spa water is not covered by the warranty.

Air-Valve Adjustment (For quick inflation/deflation valve Only)

In case of air leakage, check the air-valve first. Using soapy water, cover the air-valve to check if air is leaking, if so, use the provided wrench to fasten the air-valve following these steps:

- With one hand, hold the backside of the air-valve from the inner side of the spa wall and turn the wrench clockwise.

NOTE:

1. Do not over tighten.
2. Always check the air-valve carefully before use.
3. Do not adjust the air-valve connector when the spa is in use.



STORAGE

Draining the Spa

1. Turn the drain valve clockwise.

2. Turn the drain valve counter-clockwise.

3. Attach the drain hose.

4. Connect the drain hose to the spa.

5. Plug the drain hose into the ground.

6. Turn the drain valve clockwise to drain.

7. Lift up the spa when there is only a little water left. Damages to the handles are not covered under the warranty.

8. NOTE: Dry the spa pool.

Cleaning the spa Detergent residues and dissolved solids from bathing suits and chemicals may build up on the spa walls. Use soap and water to clean the walls and rinse thoroughly.

NOTE: DO NOT use hard brushes or abrasive cleaners.

DEFLATION

1. Disconnect the air valve.

2. Turn the quick inflation/deflation valve counter-clockwise.

3. Turn the safety valve counter-clockwise.

P61726ASS18		
P61725ASS18		
P61727ASS18		

REPAIR

For PVC part.

If the spa is torn or punctured, use the provided underwater adhesive repair patch.

1. Clean area to be repaired.
2. Carefully peel patch.
3. Press patch over area to be repaired.
4. Wait 30 seconds before inflation.

For Tritech PVC material.

If the spa is torn or punctured, use the provided PVC repair patch and glue (not included) following these steps:



1. Clean and dry area to be repaired.
2. Cut the provided PVC patch to appropriate size.
3. Use glue (not included) to coat the one side of the newly cut patch. Make sure the glue is evenly distributed.
4. Wait for 30 seconds and then place the cut patch with glue over the damaged area.
5. Smooth out any bubbles of air that may be trapped underneath, and press firmly for two minutes.
6. The product is once again ready for use. Repeat this process should further leaks occur.
7. Wait 30 minutes before inflation.

Make sure the spa and pump are completely dry. This is essential to extend the life of the spa. It is recommended you store the spa in its original package in a warm dry place.

NOTE: Plastic becomes brittle and susceptible to breaking when exposed to subzero temperatures. Freezing can severely damage the spa. Improper winterization of your spa can void your warranty.

TROUBLESHOOTING

Bestway strives to provide the most trouble-free Spas on the market. If you experience any problems whatsoever, do not hesitate to contact Bestway or your authorized dealer. Here are some helpful tips to help you to diagnose and rectify some common sources of trouble.

Problems	Probable Causes	Solutions
Pump does not operate	<ul style="list-style-type: none"> - Power failure - GFCI broken 	<ul style="list-style-type: none"> - Check power source - To get assistance visit our website www.bestwaycorp.com support section
Pump does not heat properly	<ul style="list-style-type: none"> - Temperature set too low - Dirty Filter Cartridge - The thermal cut-out cut off - Spa is not covered - Heating element failed or fuse cutout 	<ul style="list-style-type: none"> - Set to a higher temperature refer to section pump operation - Clean/replace the filter cartridge refer to section filter cartridge cleaning and replacement - Unplug the pump, and put the plug in a dry, cool place. Only restart the pump when the water temperature reaches 35°C (95°F) or lower - Attach the cover. - To get assistance visit our website www.bestwaycorp.com support section
Massage System does not work	<ul style="list-style-type: none"> - Air Pump is overheating - The massage system stops automatically - Air pump is broken 	<ul style="list-style-type: none"> - Unplug the pump and wait two hours until the pump has cooled. Insert the plug and press the massage system button - Press the massage system button to reactivate - To get assistance visit our website www.bestwaycorp.com support section
Pump adapters are not level with the spa adapters	<ul style="list-style-type: none"> - One characteristic of PVC is that it changes shape, which is normal 	<ul style="list-style-type: none"> - Elevate the pump with wood or another type of insulated material to bring the pump's adapters level with the spa's adapters
Spa pool leakage	<ul style="list-style-type: none"> - Spa is torn or punctured - Air valve is loose 	<ul style="list-style-type: none"> - Use provided repair patch - Using soapy water, cover the air-valve to check if air is leaking, if so, use the provided wrench to fasten the air-valve following these steps: <ol style="list-style-type: none"> 1. Deflate the SPA. 2. With one hand, hold the backside of the air valve from the inner side of the spa wall and turn the wrench clockwise.
Water is not clean	<ul style="list-style-type: none"> - Insufficient filtering time - Dirty Filter Cartridge - Improper water maintenance 	<ul style="list-style-type: none"> - Increase filtration time - Clean/replace the Filter Cartridge (refer to Filter Cartridge Cleaning and Replacement section) - Refer to the chemical manufacturer's instructions
Control panel not working	<p>The control panel has an auto-lock, which is activated after 5 minutes of inactivity. The LED display has one icon:  If the lock icon is highlighted, the control panel is locked.</p> <ul style="list-style-type: none"> - Control panel is not activated. 	<ul style="list-style-type: none"> - To unlock the control panel, press the  button for 3 seconds. If the control panel will not unlock, restart the pump – unplug and plug in the pump. - Press the on/off button for 2 seconds. If the problem persists, to get assistance visit our website www.bestwaycorp.com support section.
GFCI test failed	There is a defect in your SPA	To get assistance visit our website www.bestwaycorp.com support section
What kind of chemicals should be used for water maintenance?	Please consult your local chemical supplier for information about chemical maintenance. Pay close attention to the chemical manufacturer's instructions.	
Water leaks from the adapters between the pump and spa	Insert the three stopper caps on to the spa's ports to prevent water from escaping and disconnect the pump. Check and make sure the seals are placed correctly inside the pump adapters. If the seals are missing or not installed correctly, to get assistance visit our website www.bestwaycorp.com support section. If the seals are correctly in place, reconnect the pump to the SPA and hand-tighten the adapters.	
APP can not connect to the network	The router is too far and the wifi signal is too weak	<ul style="list-style-type: none"> -Keep the router close to the device -To get assistance visit our website www.bestwaycorp.com support section



For support please visit us at:
bestwaycorp.com/support

©2019 Bestway Inflatables & Material Corp.

All rights reserved/Tous droits réservés/Todos los derechos reservados/Alle Rechte vorbehalten/Tutti i diritti riservati

®™ Trademarks used in some countries under license to/

Marques ®™ utilisées dans certains pays sous la licence de/

Marcas comerciales ®™ utilizadas en algunos países bajo la licencia de/

®™ Die Warenzeichen werden in einigen Ländern verwendet unter Lizenz der/

®™ Marchi utilizzati in alcuni paesi concessi in licenza a

Bestway Inflatables & Material Corp., No.3065 Cao An Road, Shanghai, 201812, China.

Manufactured, distributed and represented in the European Union by/

Fabriqués, distribués et représentés dans l'Union Européenne par/Fabricado, distribuido y representado en la Unión Europea por/

Hergestellt, vertrieben und in der Europäischen Union vertreten von/Prodotto, distribuito e rappresentato nell'Unione Europea da

Bestway (Europe) S.r.l., Via Resistenza, 5, 20098 San Giuliano Milanese (Milano), Italy

Distributed in North America by/Distribués en Amérique du Nord par/Distribuido en Norteamérica por

Bestway (USA) Inc., 3411 E. Harbour Drive, Phoenix, Arizona 85034, United States of America

Tel: +86 21 69135588 (For U.S. and Canada)

Distributed in Latin America by/Distribué en Amérique latine par/Distribuido en Latinoamérica por/Distribuido na América Latina por

Bestway Central & South America Ltda, Salar Ascotan 1282, Parque Enea, Pudahuel, Santiago, Chile

Distributed in Australia & New Zealand by **Bestway Australia Pty Ltd, 98-104 Carnarvon Street, Silverwater, NSW 2128, Australia**

Tel: Australia: (+61) 29 0371 388; New Zealand: 0800 142 101

Exported by/Exporté par/Exportado por/Exportiert von/Esportato da

Bestway (Hong Kong) International Ltd./Bestway Enterprise Company Limited

Suite 713, 7/Floor, East Wing, Tsim Sha Tsui Centre, 66 Mody Road, Kowloon, Hong Kong

www.bestwaycorp.com

Made in China/Fabriqué en Chine/Fabricado en China/Hergestellt in China/Prodotto in Cina