

The CirrusSense™
TDWLБ-LC Series
Low Cost/OEM,
Lightweight
Wireless Bluetooth
Pressure Transducer



Preliminary

SERIES: TDWLБ-LC



FEATURES

- Ultem 2300, Industry First, Lightweight
- Connects to smart phones and tablets with BLE (Bluetooth® Low Energy)
- Remote Monitoring Capability Available
- Pressure ranges up to 1,000 psi
- 1% Standard accuracy
- Long battery life (proprietary technology)
- Alarm set points
- Secure field programmable naming
- Patent Pending Design

SPECIFICATIONS

*PRELIMINARY

Performance	Performance @ 25°C (77 °F)
Pressure Accuracy	1% BFSL (includes: Non-linearity, Hysteresis and Non-repeatability)
Overrange Protection	1.5x Rated Pressure
Pressure Range	up to 1,000 psi
Update Time	Bluetooth® wireless technology (1sec)
Environmental Data	
Temperature	
Compensated Temperatures	-25°C (-13°F) to 60°C (140°F)
Operating Temperatures	-30°C (-22°F) to 60°C (140°F)
Storage Temperatures	-30°C (-22°F) to 60°C (140°F)
TEB	3% of FS
Long Term Drift	0.2% FS/year (non-cumulative)
EMI/RFI Protection	Yes
Rating	IP-67
Mechanical Configuration	
Pressure Connections	7/16-20 UNF Female w/ 45° flare & valve depressor
Wetted Material	Ultem 2300 engineered composite material
Electrical Data	
Power Supply	Replaceable battery, battery life: 24+ months

Compatible Devices

Software:	Android - Version 4.3 or later	
	iOS - Current version and previous one	
Hardware:	Android - Device supports Bluetooth Smart (Version 4.0 and later)	
	iPad Gen 3 (released March 16, 2012)	iPad Air (released November 1, 2013)
	iPad Gen 4 (released November 2, 2012)	iPhone 5 (released September 21, 2012)
	iPad Mini Gen 1 (released November 2, 2012)	iPhone 5C, 5S (released September 20, 2013)
	iPad Mini Gen 2 (released November 12, 2013)	iPhone 6, 6 Plus (released September 19, 2014)
		iPhone 7, 7 Plus (released September 16, 2016)

Specifications may change without notice. The information we supply is believed to be accurate and reliable as of this printing. However, we assume no responsibility for its use. While we provide application assistance personally, through our literature and the Transducers Direct web site, it is up to the customer to determine the suitability of the product in the application.

TDWLB-LC APP

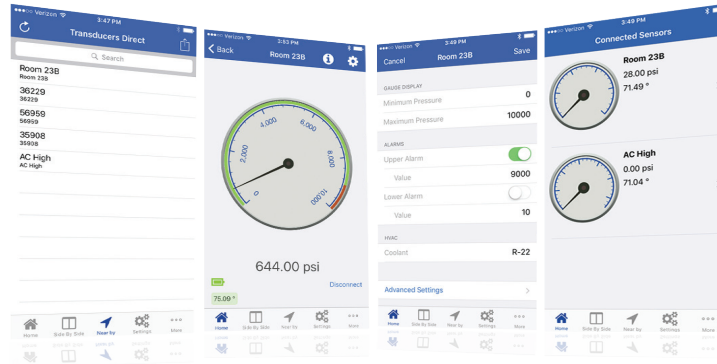

Free download at the Apple iTunes App Store and Google Play

Specifications may change without notice. The information we supply is believed to be accurate and reliable as of this printing. However, we assume no responsibility for its use. While we provide application assistance personally, through our literature and the Transducers Direct web site, it is up to the customer to determine the suitability of the product in the application.

DIMENSIONS

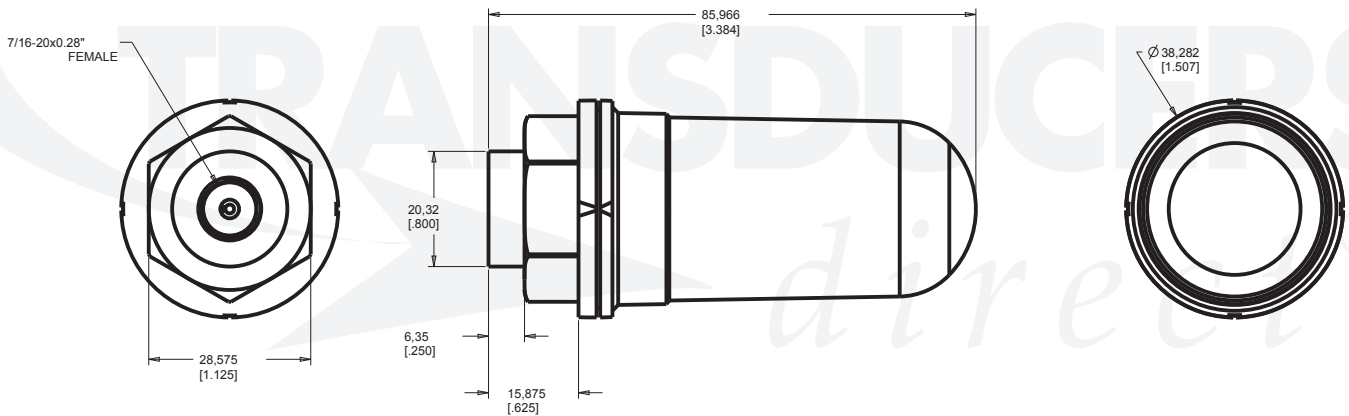

Dimensions in mm [inches] and for reference only

ORDERING

Series	Pressure Range	Pressure Connection	Accuracy	Battery Pack
TDWLB-LC	0500 (psi)	42	4	
	0050	42= 7/16-20 UNF	4 = 1.0%	Blank= standard battery pack
	0100	Female		
	0500	w/ 45° flare & valve		
	0650	depressor (Schrader)		
	1000	**		
	**			

**= Consult factory for further OEM options.

Pressure ranges listed above are quick ship versions.

All straight-thread o-rings are Viton. It is customer's responsibility to determine compatibility.

FCC Warning

This equipment has been tested and found to comply with the limits for a Class B digital device, pursuant to part 15 of the FCC Rules.

These limits are designed to provide reasonable protection against harmful interference in a residential installation.

This equipment generates, uses and can radiate radio frequency energy and, if not installed and used in accordance with the instructions, may cause harmful interference to radio communications. However, there is no guarantee that interference will not occur in a particular installation. If this equipment does cause harmful interference to radio or television reception, which can be determined by turning the equipment off and on, the user is encouraged to try to correct the interference by one or more of the following measures:

- Reorient or relocate the receiving antenna.
- Increase the separation between the equipment and receiver.
- Connect the equipment into an outlet on a circuit different from that to which the receiver is connected.
- Consult the dealer or an experienced radio/TV technician for help

This device complies with part 15 of the FCC Rules. Operation is subject to the following two conditions: (1) This device may not cause harmful interference, and (2) this device must accept any interference received, including interference that may cause undesired operation.

Caution: Any changes or modifications to this device not expressly approved by the party responsible for compliance could void your authority to operate the equipment.

This equipment complies with FCC radiation exposure limits set forth for an uncontrolled environment. This equipment should be installed and operated with minimum 20 cm between the radiator and your body. This transmitter must not be collocated or operating in conjunction with any other antenna or transmitter unless authorized to do so by the FCC.

IC Warning

This device complies with Industry Canada license-exempt RSS standard(s). Operation is subject to the following two conditions: (1) This device may not cause interference; and (2) This device must accept any interference, including interference that may cause undesired operation of the device.

Le présent appareil est conforme aux CNR d'Industrie Canada applicables aux appareils radio exempts de licence. L'exploitation est autorisée aux deux conditions suivantes : (1) l'appareil ne doit pas produire de brouillage, et (2) l'utilisateur de l'appareil doit accepter tout brouillage radioélectrique subi, même si le brouillage est susceptible d'en compromettre le fonctionnement.

RF Exposure

The antenna (or antennas) must be installed so as to maintain at all times a distance minimum of at least 20 cm between the radiation source (antenna) and any individual. This device may not be installed or used in conjunction with any other antenna or transmitter.

l'exposition aux RF

L'antenne (ou les antennes) doit être installée de façon à maintenir tout instant une distance minimum de au moins 20 cm entre la source de radiation (l'antenne) et toute personne physique.