

# FCC Test Report

G4S Monitoring Technologies Limited

Model: SOLO3 RevD

In accordance with FCC 47 CFR Part 2, FCC 47 CFR Part 15, FCC 47 CFR Part 22, FCC 47 CFR Part 24 and FCC 47 CFR Part 27

(Bluetooth Low Energy + 2.4 GHz WLAN  
+ GSM 850 + 915 MHz + 16 MHz)

Prepared for: G4S Monitoring Technologies Limited  
3 Centurion Court, Meridian East  
Leicester, Leicestershire  
LE19 1TP, UNITED KINGDOM



Add value.  
Inspire trust.

FCC ID: 2ACGBSOL3915

## COMMERCIAL-IN-CONFIDENCE

Document 75956356-09 Issue 02

### SIGNATURE

NAME	JOB TITLE	RESPONSIBLE FOR	ISSUE DATE
Steve Marshall	Senior Engineer	Authorised Signatory	17 March 2023

Signatures in this approval box have checked this document in line with the requirements of TÜV SÜD document control rules.

### ENGINEERING STATEMENT

The measurements shown in this report were made in accordance with the procedures described on test pages. All reported testing was carried out on a sample equipment to demonstrate limited compliance with FCC 47 CFR Part 2, FCC 47 CFR Part 15, FCC 47 CFR Part 22, FCC 47 CFR Part 24 and FCC 47 CFR Part 27. The sample tested was found to comply with the requirements defined in the applied rules.

RESPONSIBLE FOR	NAME	DATE	SIGNATURE
Testing	Pier-Angelo Lorusso	28 February 2023	

FCC Accreditation  
90987 Octagon House, Fareham Test Laboratory

### EXECUTIVE SUMMARY

A sample of this product was tested and found to be compliant with FCC 47 CFR Part 2: 2021, FCC 47 CFR Part 15: 2021, FCC 47 CFR Part 22: 2021, FCC 47 CFR Part 24: 2021 and FCC 47 CFR Part 27: 2021 for the tests detailed in section 1.3.



### DISCLAIMER AND COPYRIGHT

This non-binding report has been prepared by TÜV SÜD with all reasonable skill and care. The document is confidential to the potential Client and TÜV SÜD. No part of this document may be reproduced without the prior written approval of TÜV SÜD. © 2023 TÜV SÜD. This report relates only to the actual item/items tested.

### ACCREDITATION

Our UKAS Accreditation does not cover opinions and interpretations and any expressed are outside the scope of our UKAS Accreditation. Results of tests not covered by our UKAS Accreditation Schedule are marked NUA (Not UKAS Accredited).

TÜV SÜD  
is a trading name of TÜV SÜD Ltd  
Registered in Scotland at East Kilbride,  
Glasgow G75 0QF, United Kingdom  
Registered number: SC215164

TÜV SÜD Ltd is a  
TÜV SÜD Group Company

Phone: +44 (0) 1489 558100  
Fax: +44 (0) 1489 558101  
[www.tuvsud.com/en](http://www.tuvsud.com/en)

TÜV SÜD  
Octagon House  
Concorde Way  
Fareham  
Hampshire PO15 5RL  
United Kingdom



## Contents

<b>1</b>	<b>Report Summary .....</b>	<b>2</b>
1.1	Report Modification Record.....	2
1.2	Introduction.....	2
1.3	Brief Summary of Results .....	3
1.4	Application Form .....	4
1.5	Product Information .....	8
1.6	Deviations from the Standard.....	8
1.7	EUT Modification Record .....	8
1.8	Test Location .....	8
<b>2</b>	<b>Test Details .....</b>	<b>9</b>
2.1	Radiated Spurious Emissions (Simultaneous Transmission) .....	9
<b>3</b>	<b>Photographs .....</b>	<b>19</b>
3.1	Test Setup Photographs .....	19
<b>4</b>	<b>Measurement Uncertainty .....</b>	<b>20</b>



# 1 Report Summary

## 1.1 Report Modification Record

Alterations and additions to this report will be issued to the holders of each copy in the form of a complete document.

Issue	Description of Change	Date of Issue
1	First Issue	28-February-2023
2	Add FCC ID and amend model number	17-March-2023

**Table 1**

## 1.2 Introduction

Applicant	G4S Monitoring Technologies Limited
Manufacturer	G4S Monitoring Technologies Limited
Model Number(s)	SOLO3 RevD
Serial Number(s)	SOLGMT603023
Hardware Version(s)	Rev D
Software Version(s)	9.3.7
Number of Samples Tested	1
Test Specification/Issue/Date	FCC 47 CFR Part 2: 2021 FCC 47 CFR Part 15: 2021 FCC 47 CFR Part 22: 2021 FCC 47 CFR Part 24: 2021 FCC 47 CFR Part 27: 2021
Order Number	MT0009267
Date	15-August-2022
Date of Receipt of EUT	17-August-2022
Start of Test	11-October-2022
Finish of Test	09-December-2022
Name of Engineer(s)	Pier-Angelo Lorusso
Related Document(s)	ANSI C63.26: 2015 ANSI C63.10: 2013 KDB 996369 D04 Module Integration Guide v02



### 1.3 Brief Summary of Results

A brief summary of the tests carried out in accordance with FCC 47 CFR Part 2, FCC 47 CFR Part 15, FCC 47 CFR Part 22, FCC 47 CFR Part 24 and FCC 47 CFR Part 27 is shown below.

Section	Specification Clause					Test Description	Result	Comments/Base Standard
	FCC Part 2	FCC Part 15	FCC Part 22	FCC Part 24	FCC Part 27			
Configuration and Mode: 802.11(b) + GSM 850 + 915 MHz SRD + 16 MHz SRD - SOLO3 connected to SPC								
2.1	2.1053	15.209 and 15.247 (d)	22.917 (a)	-	-	Radiated Spurious Emissions (Simultaneous Transmission)	Pass	ANSI C63.10 2013 & ANSI C63.26: 2015
Configuration and Mode: 802.11(b) + UMTS FDD BII + 915 MHz SRD + 16 MHz SRD - SOLO3 connected to SPC								
2.1	2.1053	15.209 and 15.247 (d)	-	24.238 (a)	-	Radiated Spurious Emissions (Simultaneous Transmission)	Pass	ANSI C63.10 2013 & ANSI C63.26: 2015
Configuration and Mode: Bluetooth Low Energy + LTE FDD B12 + 915 MHz SRD + 16 MHz SRD - SOLO3 connected to SPC								
2.1	2.1053	15.209 and 15.247 (d)	-		27.53 (g)	Radiated Spurious Emissions (Simultaneous Transmission)	Pass	ANSI C63.10 2013 & ANSI C63.26: 2015

**Table 2**



## 1.4 Application Form

### Equipment Description

Technical Description: <i>(Please provide a brief description of the intended use of the equipment including the technologies the product supports)</i>	The SOLO3 REVD is ankle tagging SRD with BLE, WiFi, GNSS and 2G/3G/4G cellular capabilities	
Manufacturer:	G4S Monitoring Technologies LTD	
Model:	SOLO3 REVD	
Part Number:	40-000213 (SOLO3 Assembly)	
Hardware Version:	Rev D	
Software Version:	9.3.7	
FCC ID of the product under test – <a href="#">see guidance here</a>	2ACGBSOL3915	
IC ID of the product under test – <a href="#">see guidance here</a>		

**Table 3**



Intentional Radiators

Technology	ISM Radio beacon	Cellular 3G and 4G	Metal Detect Board	BLE/ WiFi
Frequency Range (MHz to MHz)	915.25 MHz	699-1990 (B2,4,5,12,13)	16MHz	2.402GHz to 2.48GHz for BLE and 2.412GHz to 2.484GHz
Conducted Declared Output Power (dBm)	+14	+33	-71.28	+18
Antenna Gain (dBi)	-6.01		NA (Near Field only)	1.65
Supported Bandwidth(s) (MHz) (e.g. 1 MHz, 20 MHz, 40 MHz)	125KHz		NA (Continuous wave mode)	20MHz
Modulation Scheme(s) (e.g. GFSK, QPSK etc)	GFSK		No Modulation	
ITU Emission Designator ( <a href="#">see guidance here</a> ) (not mandatory for Part 15 devices)			N.A (Near Field emission; Extremely low power)	
Bottom Frequency (MHz)	915.125	699	15	2.402
Middle Frequency (MHz)	915.25	B5 (850) and B4 (1700)	16	2.44
Top Frequency (MHz)	915.375	2155	17	2.484

**Table 4**



Un-intentional Radiators

Highest frequency generated or used in the device or on which the device operates or tunes	
Lowest frequency generated or used in the device or on which the device operates or tunes	32.768 KHz
Class A Digital Device (Use in commercial, industrial or business environment) <input type="checkbox"/>	
Class B Digital Device (Use in residential environment only) <input checked="" type="checkbox"/>	

**Table 5**

AC Power Source

AC supply frequency:	50	Hz
Voltage	100-240	V
Max current:	3	A
Single Phase <input checked="" type="checkbox"/> Three Phase <input type="checkbox"/>		

**Table 6**

DC Power Source

Nominal voltage:	5.1	V
Extreme upper voltage:	5.5	V
Extreme lower voltage:	5.7	V
Max current:	3	A

**Table 7**

Battery Power Source

Voltage:	3.7	V
End-point voltage:	3.2	V (Point at which the battery will terminate)
Alkaline <input type="checkbox"/> Leclanche <input type="checkbox"/> Lithium <input checked="" type="checkbox"/> Nickel Cadmium <input type="checkbox"/> Lead Acid* <input type="checkbox"/> *(Vehicle regulated)		
Other <input type="checkbox"/>	Please detail:	

**Table 8**

Charging

Can the EUT transmit whilst being charged	Yes <input checked="" type="checkbox"/> No <input type="checkbox"/>
---	---

**Table 9**

Temperature

Minimum temperature:	0	°C
Maximum temperature:	45	°C

**Table 10**



Cable Loss

Adapter Cable Loss (Conducted sample)	0.5 (estimated)	dB
--	-----------------	----

**Table 11**

Antenna Characteristics

Antenna connector <input checked="" type="checkbox"/> Pogo pins for ISM 866.5MHz/915.25MHz and cellular			State impedance	50	Ohm
Temporary antenna connector <input type="checkbox"/>			State impedance		Ohm
Integral antenna <input checked="" type="checkbox"/>	Type:	Chip Monopole(BLE/Wifi), FPC (cellular and ISM 866/915MHz), Patch (GNSS)	Gain	All in Free Space: Cellular (698-960 1710-2170 2500-2690, -4.41, 0.99 and -9.54), BLE= -1.39, ISM 915MHz~1.73, Patch	dBi
External antenna <input type="checkbox"/>	Type:		Gain		dBi
For external antenna only: Standard Antenna Jack <input type="checkbox"/> If yes, describe how user is prohibited from changing antenna (if not professional installed): Equipment is only ever professionally installed <input type="checkbox"/> Non-standard Antenna Jack <input type="checkbox"/>					

**Table 12**

Ancillaries (if applicable)

Manufacturer:		Part Number:	
Model:		Country of Origin:	

**Table 13**

I hereby declare that the information supplied is correct and complete.

Name: Kelvin Wong  
 Position held: Senior RF and Electronics Engineer  
 Date: 09 November 2022





**1.5 Product Information**

**1.5.1 Technical Description**

The SOLO3 REVD is ankle tagging SRD with BLE, WiFi, GNSS and 2G/3G/4G cellular capabilities.

**1.6 Deviations from the Standard**

No deviations from the applicable test standard were made during testing.

**1.7 EUT Modification Record**

The table below details modifications made to the EUT during the test programme.

The modifications incorporated during each test are recorded on the appropriate test pages.

Modification State	Description of Modification still fitted to EUT	Modification Fitted By	Date Modification Fitted
Model: SOLO3 REVD RevD, Serial Number: SOLGMT603023			
0	As supplied by the customer	Not Applicable	Not Applicable

**Table 14**

**1.8 Test Location**

TÜV SÜD conducted the following tests at our Octagon House Test Laboratory.

Test Name	Name of Engineer(s)	Accreditation
Configuration and Mode: 802.11(b) + GSM 850 + 915 MHz SRD + 16 MHz SRD - SOLO3 REVD connected to SPC		
Radiated Spurious Emissions (Simultaneous Transmission)	Pier-Angelo Lorusso and Lauren Walters	UKAS
Configuration and Mode: 802.11(b) + UMTS FDD BII + 915 MHz SRD + 16 MHz SRD - SOLO3 REVD connected to SPC		
Radiated Spurious Emissions (Simultaneous Transmission)	Pier-Angelo Lorusso and Lauren Walters	UKAS
Configuration and Mode: Bluetooth Low Energy + LTE FDD B12 + 915 MHz SRD + 16 MHz SRD - SOLO3 REVD connected to SPC		
Radiated Spurious Emissions (Simultaneous Transmission)	Pier-Angelo Lorusso and Lauren Walters	UKAS

**Table 15**

Office Address:

TÜV SÜD  
 Octagon House  
 Concorde Way  
 Fareham  
 Hampshire  
 PO15 5RL  
 United Kingdom



## 2 Test Details

### 2.1 Radiated Spurious Emissions (Simultaneous Transmission)

#### 2.1.1 Specification Reference

FCC 47 CFR Part 2, Clause 2.1053  
FCC 47 CFR Part 15, Clause 15.209 and 15.247 (d)  
FCC 47 CFR Part 22, Clause 22.917 (a)  
FCC 47 CFR Part 24, Clause 24.238 (a)  
FCC 47 CFR Part 27, Clause 27.53 (g)

#### 2.1.2 Equipment Under Test and Modification State

SOLO3 RevD, S/N: SOLGMT603023 - Modification State 0

#### 2.1.3 Date of Test

11-October-2022 to 09-December-2022

#### 2.1.4 Test Method

A preliminary profile of the Radiated Spurious Emissions was obtained up to the 5th harmonic by operating the EUT on a remotely controlled turntable within a semi-anechoic chamber. Measurements of emissions from the EUT were obtained with the Measurement Antenna in both Horizontal and Vertical Polarisations. The profiling produced a list of the worst-case emissions together with the EUT azimuth and antenna polarisation.

Testing was performed in accordance with ANSI C63.26, Clause 5.5.

Field strength measurements were performed and then converted to Equivalent Power Measurements in accordance with ANSI C63.26, Clause 5.2.7 equation c)

Example calculation:

$E \text{ (dBuV/m)} + 20\log(d) - 104.8 = \text{EIRP (dBm)}$  where (d) is the measurement distance.

$82.2 \text{ (dBuV/m)} + 20\log(3) - 104.8 = \text{EIRP (dBm)}$

$-13.0 = \text{EIRP (dBm)}$

The frequency spectrum investigated was up to the 5<sup>th</sup> harmonic, as specified in 15.33 (b) required by KDB 996369 D04 Module Integration Guide clause 3.2. Measurements were made on the worst case modulation and channel as specified in the original equipment filing.

### 2.1.5 Example Test Setup Diagram

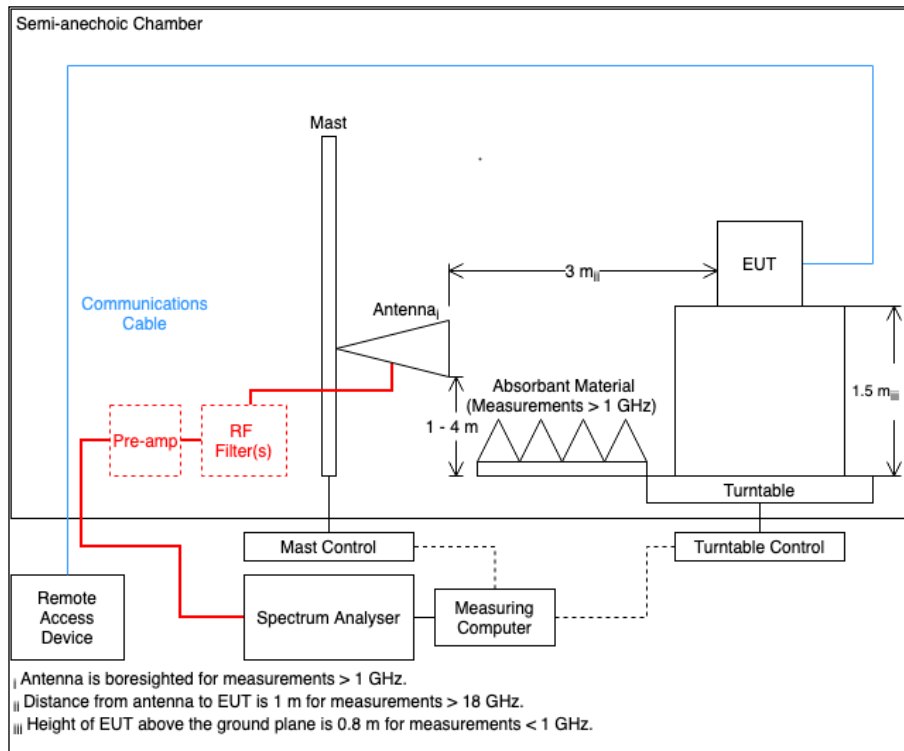


Figure 1

### 2.1.6 Environmental Conditions

Ambient Temperature	18.8 - 20.7 °C
Relative Humidity	29.8 - 59.4 %



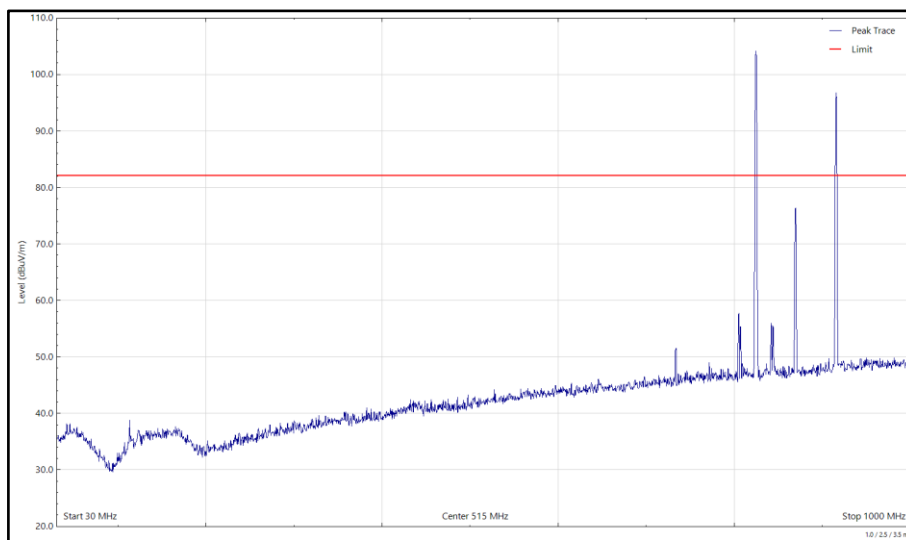
**2.1.7 Test Results**

802.11(b) + GSM 850 + 915 MHz SRD + 16 MHz SRD - SOLO3 REVD connected to SPC

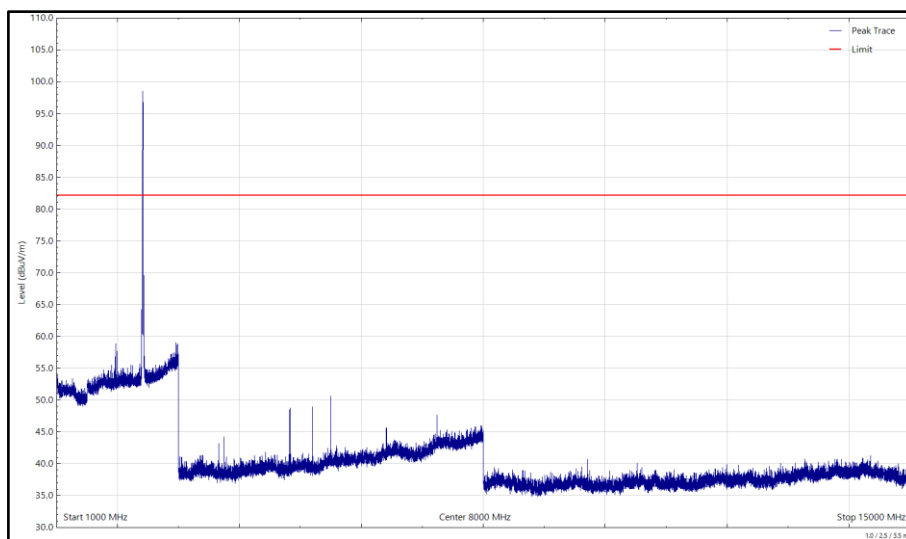
Frequency (MHz)	Level (dBuV/m)	Limit (dBuV/m)	Margin (dB)	Detector	Angle (°)	Height (cm)	Polarisation
*							

**Table 16 - 802.11b – 2412 MHz (CH1), GSM850 – 824.2 MHz, SRD – 915 MHz, ISM – 16 MHz, 30 MHz to 15 GHz**

\*No emissions found within 10 dB of the limit.



**Figure 2 - 802.11b – 2412 MHz (CH1), GSM850 – 824.2 MHz, SRD – 915 MHz, ISM – 16 MHz, 30 MHz to 1 GHz, Horizontal (Peak)**



**Figure 3 - 802.11b – 2412 MHz (CH1), GSM850 – 824.2 MHz, SRD – 915 MHz, ISM – 16 MHz, 1 GHz to 15 GHz, Horizontal (Peak)**

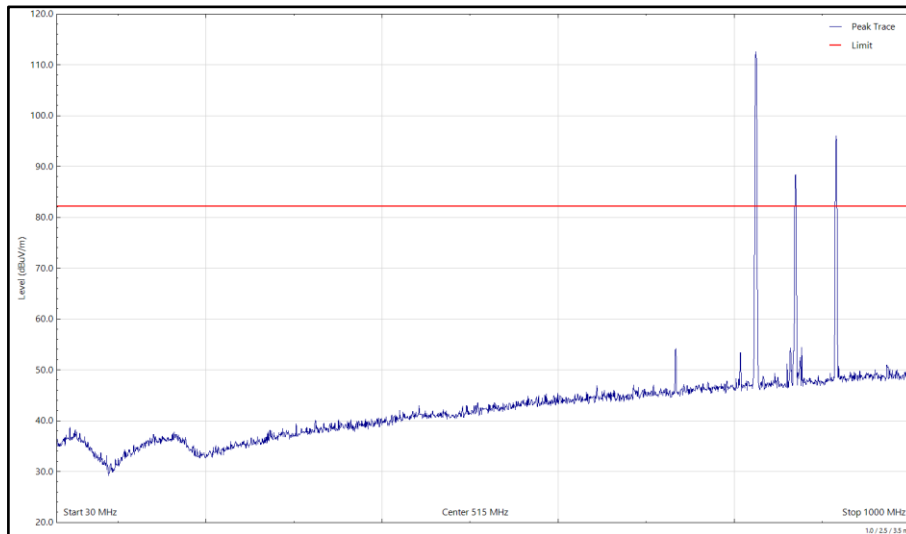


Figure 4 - 802.11b – 2412 MHz (CH1), GSM850 – 824.2 MHz, SRD – 915 MHz, ISM – 16 MHz, 30 MHz to 1 GHz, Vertical (Peak)

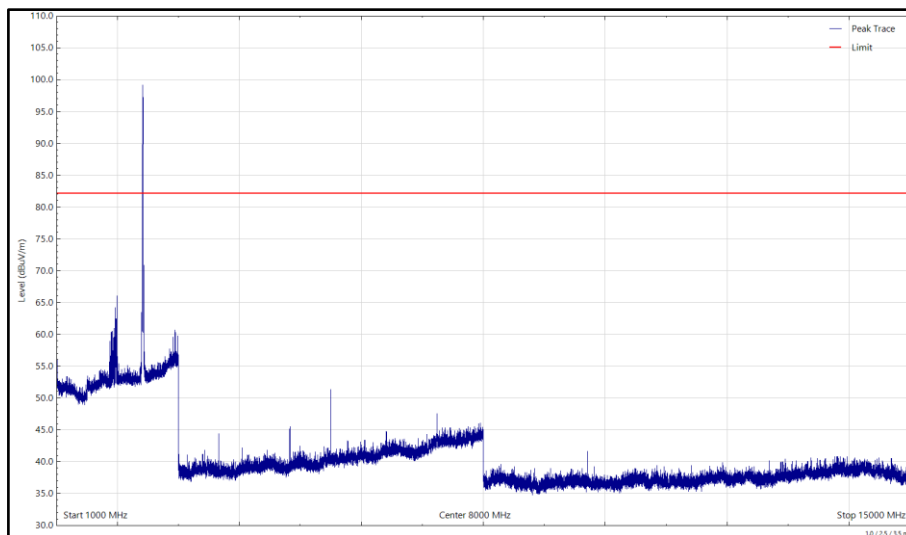


Figure 5 - 802.11b – 2412 MHz (CH1), GSM850 – 824.2 MHz, SRD – 915 MHz, ISM – 16 MHz, 1 GHz to 15 GHz, Vertical (Peak)

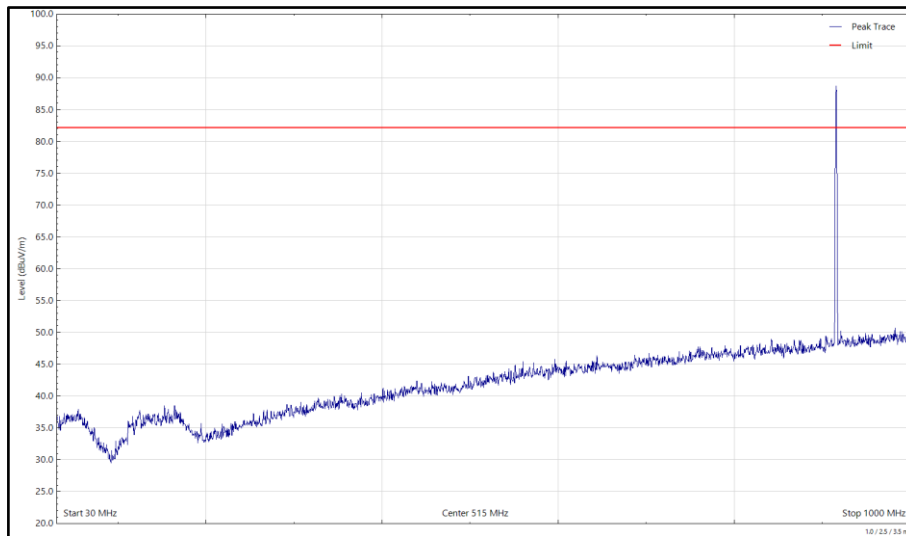


**802.11(b) + UMTS FDD BII + 915 MHz SRD + 16 MHz SRD - SOLO3 REVD connected to SPC**

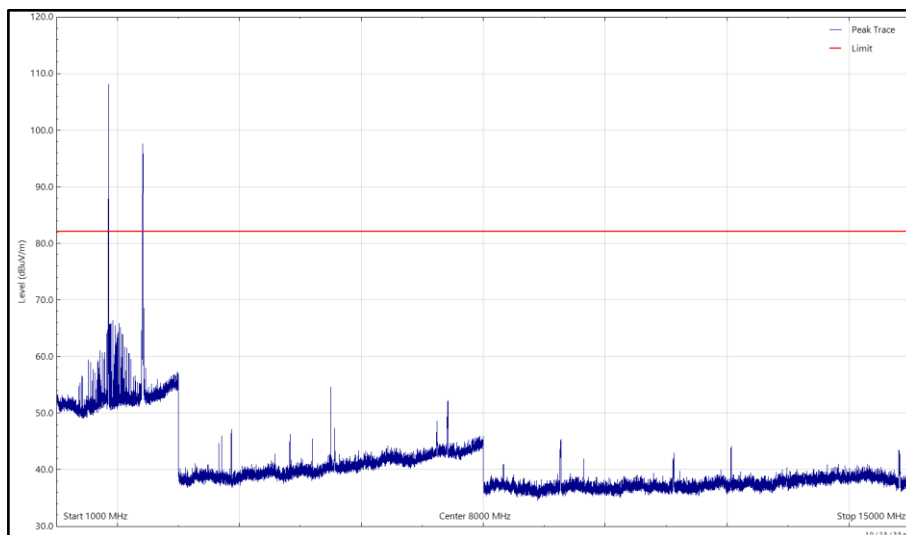
Frequency (MHz)	Level (dBuV/m)	Limit (dBuV/m)	Margin (dB)	Detector	Angle (°)	Height (cm)	Polarisation
*							

**Table 17 - 802.11b – 2412 MHz (CH1), UMTS FDDII – 1852.4 MHz, SRD – 915 MHz, ISM – 16 MHz, 30 MHz to 15 GHz**

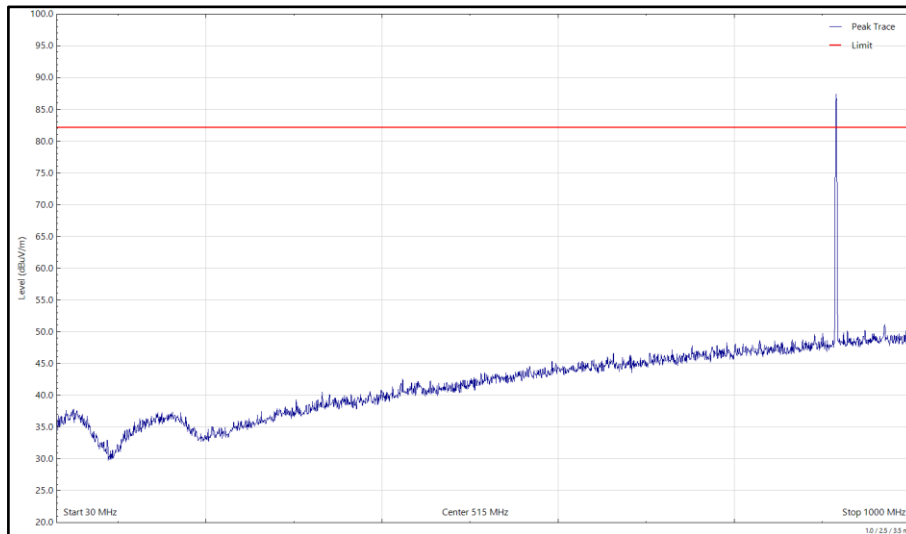
\*No emissions found within 10 dB of the limit.



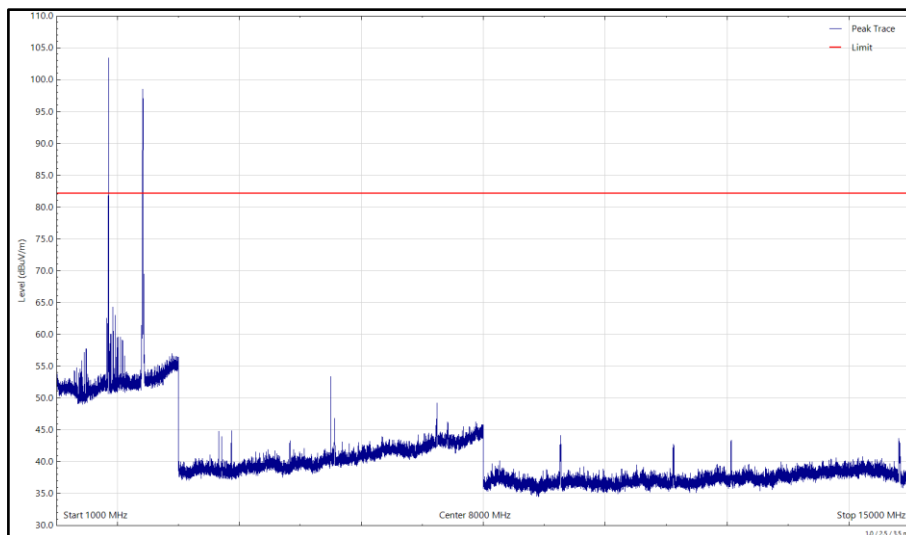
**Figure 6 - 802.11b – 2412 MHz (CH1), UMTS FDDII – 1852.4 MHz, SRD – 915 MHz, ISM – 16 MHz, 30 MHz to 1 GHz, Horizontal (Peak)**



**Figure 7 - 802.11b – 2412 MHz (CH1), UMTS FDDII – 1852.4 MHz, SRD – 915 MHz, ISM – 16 MHz, 1 GHz to 15 GHz, Horizontal (Peak)**



**Figure 8 - 802.11b – 2412 MHz (CH1), UMTS FDDII – 1852.4 MHz, SRD – 915 MHz, ISM – 16 MHz, 30 MHz to 1 GHz, Vertical (Peak)**



**Figure 9 - 802.11b – 2412 MHz (CH1), UMTS FDDII – 1852.4 MHz, SRD – 915 MHz, ISM – 16 MHz, 1 GHz to 15 GHz, Vertical (Peak)**

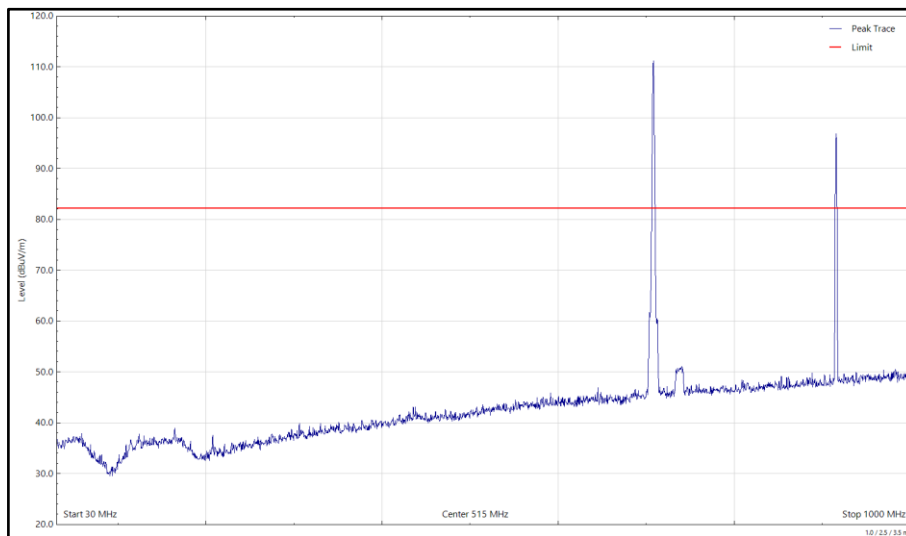


**Bluetooth Low Energy + LTE FDD B12 + 915 MHz SRD + 16 MHz SRD - SOLO3 REVD connected to SPC**

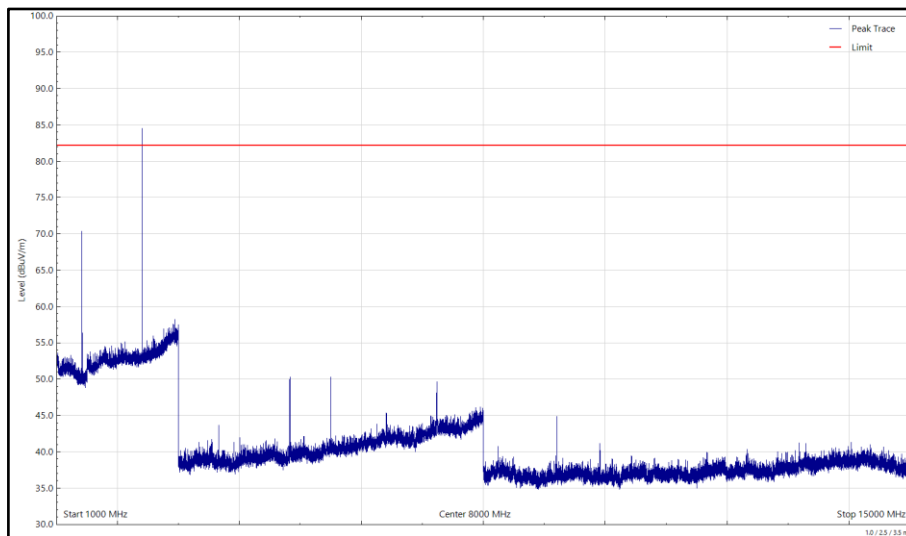
Frequency (MHz)	Level (dBuV/m)	Limit (dBuV/m)	Margin (dB)	Detector	Angle (°)	Height (cm)	Polarisation
*							

**Table 18 - BLE – 2480 MHz (CH39), LTE Band 12 – 707.5 MHz, SRD – 915 MHz, ISM – 16 MHz, 30 MHz to 15 GHz.**

\*No emissions found within 10 dB of the limit.

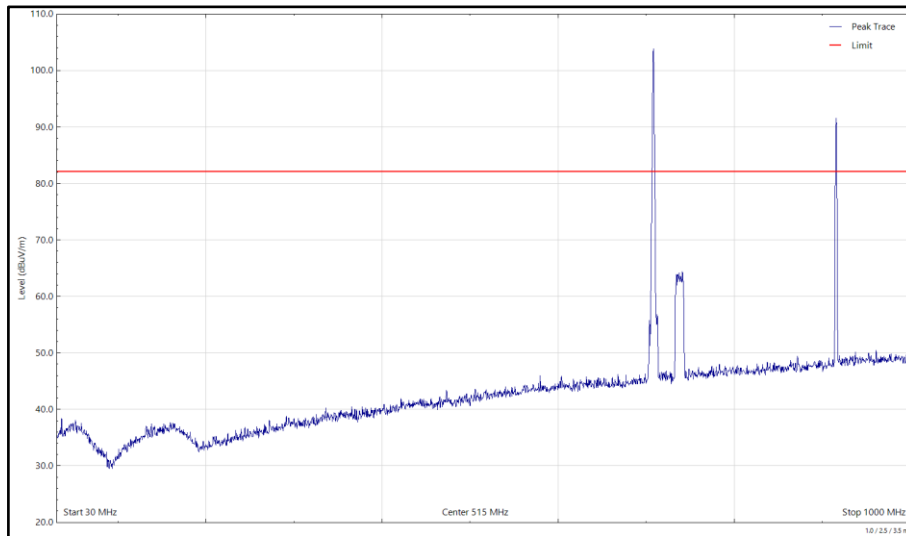


**Figure 10 - BLE – 2480 MHz (CH39), LTE Band 12 – 707.5 MHz, SRD – 915 MHz, ISM – 16 MHz, 30 MHz to 1 GHz, Horizontal (Peak)**

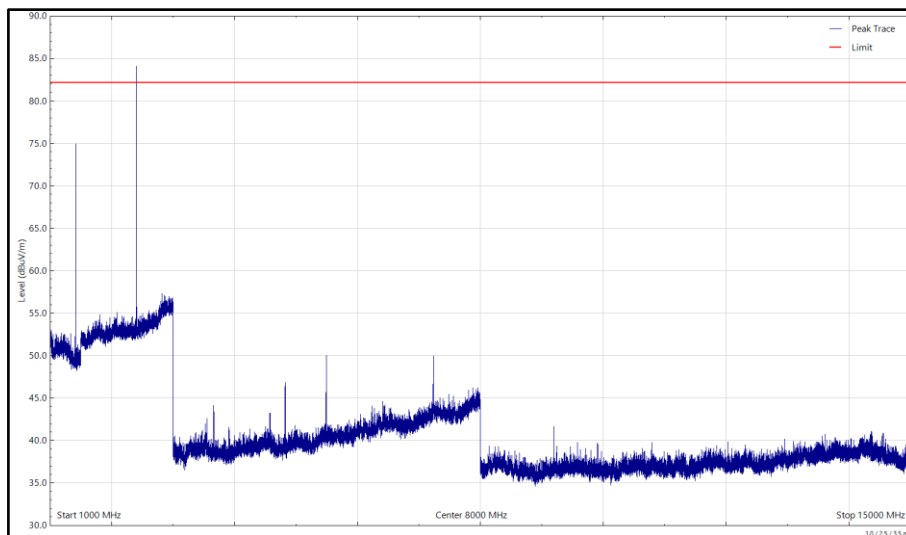


**Figure 11 - BLE – 2480 MHz (CH39), LTE Band 12 – 707.5 MHz, SRD – 915 MHz, ISM – 16 MHz, 1 GHz to 15 GHz, Horizontal (Peak)**





**Figure 12 - BLE – 2480 MHz (CH39), LTE Band 12 – 707.5 MHz, SRD – 915 MHz, ISM – 16 MHz, 30 MHz to 1 GHz, Vertical (Peak)**



**Figure 13 - BLE – 2480 MHz (CH39), LTE Band 12 – 707.5 MHz, SRD – 915 MHz, ISM – 16 MHz, 1 GHz to 15 GHz, Vertical (Peak)**



FCC 47 CR Part 15, FCC 47 CFR Part 22, FCC 47 CFR Part 24, and FCC 47 CFR Part 27

The least stringent limit from the applicable rule parts was used to determine compliance for Radiated Emissions testing of multiple transmission sources.

The least stringent applicable limit was:

Clause	Limit
Part 22.917 (a) Part 24.238 (a) Part 27.53 (g)	-13 dBm (EIRP) / 82 dB $\mu$ V/m at 3m.

**Table 19**



### 2.1.8 Test Location and Test Equipment Used

This test was carried out in RF Chamber 11.

Instrument	Manufacturer	Type No.	TE No.	Calibration Period (months)	Calibration Expiry Date
Programmable Power Supply	Iso-tech	IPS 2010	2437	-	O/P Mon
True RMS Multimeter	Fluke	179	4006	12	29-Mar-2023
High Pass filter	Wainwright	WHKX12-1290-1500-18000-80SS	4962	12	19-May-2023
Pre-Amplifier (8 GHz to 18 GHz)	Wright Technologies	PS06-0061/PS06-0060	4971	12	19-Nov-2022
EMI Test Receiver	Rohde & Schwarz	ESW44	5084	12	17-May-2023
Cable (18 GHz)	Rosenberger	LU7-071-1000	5103	12	17-Nov-2022
Emissions Software	TUV SUD	EmX V3.1.6	5125	-	Software
Screened Room (11)	Rainford	Rainford	5136	36	24-Nov-2024
Mast	Maturo	TAM 4.0-P	5158	-	TU
Mast and Turntable Controller	Maturo	Maturo NCD	5159	-	TU
Turntable	Maturo	TT 15WF	5160	-	TU
Antenna (DRG 1-10.5GHz)	Schwarzbeck	BBHA9120B	5215	12	28-May-2023
DRG Horn Antenna (7.5-18GHz)	Schwarzbeck	HWRD750	5216	12	29-May-2023
3 GHz High pass filter	Wainwright	WHKX12-2580-3000-18000-80SS	5220	12	23-Mar-2023
Thermo-Hygro-Barometer	PCE Instruments	OCE-THB-40	5470	12	07-Apr-2023
1m K-Type Cable	Junkosha	MWX241-01000KMSKMS/A	5512	12	14-Apr-2023
2m SMA Cable	Junkosha	MWX221-02000AMSAMS/A	5518	12	12-Apr-2023
8m N Type Cable	Junkosha	MWX221-08000NMSNMS/B	5522	12	24-Mar-2023
7 GHz High pass Filter	Wainwright	WHKX12-5850-6800-18000-80SS	5550	12	19-May-2023
TRILOG Super Broadband Test Antenna	Schwarzbeck	VULB 9168	5942	24	03-Feb-2024
Attenuator 4dB	Pasternack	PE7074-4	6202	24	16-Jul-2024

**Table 20**

TU – Traceability Unscheduled  
 O/P Mon – Output Monitored using calibrated equipment

### 3 Photographs

#### 3.1 Test Setup Photographs

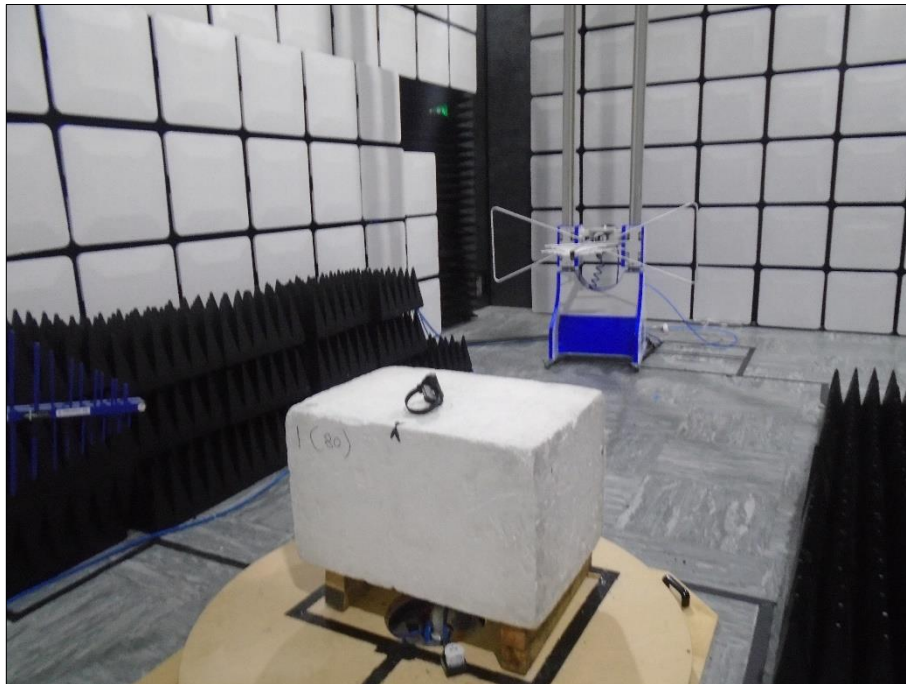


Figure 14 - Test Setup - 30 MHz to 1 GHz

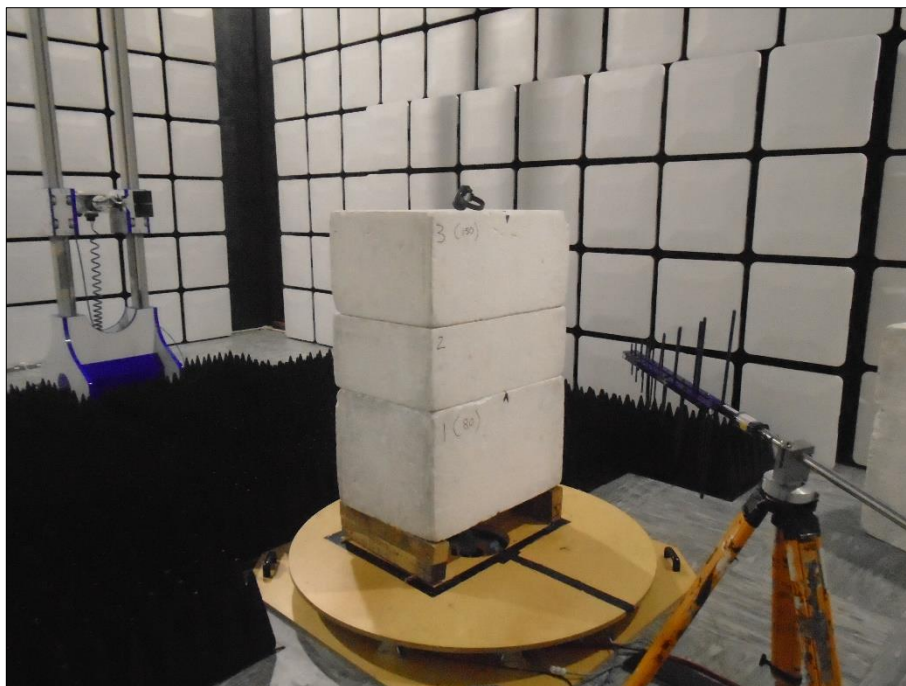


Figure 15 - Test Setup - 1 GHz to 15 GHz



## 4 Measurement Uncertainty

For a 95% confidence level, the measurement uncertainties for defined systems are:

Test Name	Measurement Uncertainty
Radiated Spurious Emissions (Simultaneous Transmission)	30 MHz to 1 GHz: $\pm 5.2$ dB 1 GHz to 40 GHz: $\pm 6.3$ dB

**Table 21**

### Measurement Uncertainty Decision Rule – Accuracy Method

Determination of conformity with the specification limits is based on the decision rule according to IEC Guide 115:2021, Clause 4.4.3 (Procedure 2). The measurement results are directly compared with the test limit to determine conformance with the requirements of the standard.

Risk: The uncertainty of measurement about the measured result is negligible with regard to the final pass/fail decision. The measurement result can be directly compared with the test limit to determine conformance with the requirement (compare IEC Guide 115). The level of risk to falsely accept and falsely reject items is further described in ILAC-G8.