



FCC RADIO TEST REPORT

Applicant : ADESSO INC.

Address : 20659 Valley BLVD. Walnut, CA 91789

Equipment : Wireless Camera

CyberView 2010, CyberView 2000, CyberView 3000, CyberView 3010, CyberView 3020, CyberView 4000, CyberView 5000, CyberView 2100, CyberView 2200, CyberView 2300, CyberView 2400, CyberView 2500, CyberView 2600, CyberView 2700, CyberView 2800, CyberView 2900, CyberView 3100, CyberView 3200, CyberView 3300, CyberView 3400, Model No. : CyberView 3500, CyberView 3600, CyberView 3700, CyberView 3800, CyberView 3900, CyberView 4100, CyberView 4200, CyberView 4300, CyberView 4400, CyberView 4500, CyberView 4600, CyberView 4700, CyberView 4800, CyberView 4900, CyberView 5100, CyberView 5200, CyberView 5300, CyberView 5400, CyberView 5500, CyberView 5600, CyberView 5700, CyberView 5800, CyberView 5900

Trade Name : Adesso /Gyration

FCC ID : 2ACFQ-2010

Standard : **FCC part 15 Subpart C § 15.247**

I HEREBY CERTIFY THAT :

The sample was received on **May. 23, 2023** and the testing was completed on **Jun. 06, 2023** at **CerpPASS Technology Corp.** The test result refers exclusively to the test presented test model / sample. Without written approval of **CerpPASS Technology Corp.**, the test report shall not be reproduced except in full.

Approved by:

Leevin Li /Supervisor



Contents

1. Summary of Test Procedure and Test Results	5
1.1 Applicable Standards	5
2. Test Configuration of Equipment under Test	6
2.1 Feature of Equipment under Test	6
2.2 Carrier Frequency of Channels	7
2.3 Test Mode and Test Software	7
2.5 Description of Test System	8
2.6 General Information of Test	10
2.7 Measurement Uncertainty	10
3. Test Equipment and Ancillaries Used for Tests	11
4. Antenna Requirements	13
4.1 Standard Applicable	13
4.2 Antenna Construction and Directional Gain	13
5. Test of Conducted Emission	14
5.1 Test Limit	14
5.2 Test Procedures	14
5.3 Typical Test Setup	15
5.4 Test Result and Data	16
6. Test of Spurious Emission (Radiated)	18
6.1 Test Limit	18
6.2 Test Procedures	18
6.3 Typical Test Setup	19
6.4 Test Result and Data (9kHz ~ 30MHz)	20
6.5 Test Result and Data (30MHz ~ 1GHz)	20
6.6 Test Result and Data (1GHz ~ 25GHz)	22
6.7 Restricted Bands of Operation	28
6.8 Restrict Band Emission Measurement Data	29
7. Test of Spurious Emission (Conducted)	33
7.1 Test Limit	33
7.2 Test Procedure	33
7.3 Test Setup Layout	33
7.4 Test Result and Data	33
8. On Time, Duty Cycle and Measurement methods	35
8.1 Test Limit	35
8.2 Test Procedure	35
8.3 Test Setup Layout	35
8.4 Test Result and Data	35
9. 6dB Bandwidth Measurement Data	37
9.1 Test Limit	37
9.2 Test Procedures	37
9.3 Test Setup Layout	37
9.4 Test Result and Data	37
10. Maximum Peak Output Power	39
10.1 Test Limit	39



10.2 Test Procedures 39

10.3 Test Setup Layout 39

10.4 Test Result and Data..... 39

11. Power Spectral Density 40

11.1 Test Limit 40

11.2 Test Procedures 40

11.3 Test Setup Layout 40

11.4 Test Result and Data..... 41



History of this test report

Version No.	Report No	Date	Description
Rev.01	DEFQ2304034	Jun. 09, 2023	Initial Issue



1. Summary of Test Procedure and Test Results

1.1 Applicable Standards

ANSI C63.10:2013

FCC Rules and Regulations Part 15 Subpart C §15.247

FCC Rule	Description of Test	Result
15.203	Antenna Requirement	PASS
15.207	AC Power Line Conducted Emission	N/A
15.209 15.205	Radiated Spurious Emission	PASS
15.247(d)	Conducted Spurious Emission	PASS
15.247(a)(2)	6dB Bandwidth	PASS
15.247(b)	Maximum Peak Output Power	PASS
15.247(e)	Power Spectral Density	PASS
Note: Deviations Yes <input type="checkbox"/> No <input checked="" type="checkbox"/> *The lab has reduced the uncertainty risk factor from test equipment, environment and staff technicians which according to the standard on contract. Therefore, the test result will only be determined by standard requirement.		



2. Test Configuration of Equipment under Test

2.1 Feature of Equipment under Test

Equipment	Wireless Camera
Model Name	CyberView 2010, CyberView 2000, CyberView 3000, CyberView 3010, CyberView 3020, CyberView 4000, CyberView 5000, CyberView 2100, CyberView 2200, CyberView 2300, CyberView 2400, CyberView 2500, CyberView 2600, CyberView 2700, CyberView 2800, CyberView 2900, CyberView 3100, CyberView 3200, CyberView 3300, CyberView 3400, CyberView 3500, CyberView 3600, CyberView 3700, CyberView 3800, CyberView 3900, CyberView 4100, CyberView 4200, CyberView 4300, CyberView 4400, CyberView 4500, CyberView 4600, CyberView 4700, CyberView 4800, CyberView 4900, CyberView 5100, CyberView 5200, CyberView 5300, CyberView 5400, CyberView 5500, CyberView 5600, CyberView 5700, CyberView 5800, CyberView 5900
Model Description	Different color or tooling Model CyberView 2010 was chosen for final test.
Operation Frequency Range	BLE: 2400MHz-2483.5MHz WIFI 2.4G: 2400MHz-2483.5MHz
Center Frequency Range	BLE: 2402MHz-2480MHz WIFI 2.4G: 802.11b/g/n(20MHz): 2412-2462MHz
Modulation Type	BLE: GFSK WIFI 2.4G: 802.11b: CCK, DQPSK, DBPSK 802.11g/n: BPSK, QPSK, 16QAM, 64QAM
Data Rate	BLE: 1Mbps WIFI 2.4G: 802.11b: 1, 2, 5.5, 11Mbps 802.11g: 6, 9, 12, 18, 24, 36, 48, 54Mbps 802.11n: HT20 reach up to 72.2Mbps,
Antenna Spec.	BLE: PCB Antenna with 0.5dBi WIFI 2.4G: PIFA Antenna with -2.49dbi
Operating Voltage	3.7V DC 2000mAh; input: DC 5.0V/1.5A
Working Temperature	-10°C to +45°C

Note: For a more detailed features description, please refer to the manufacturer's specifications or the User's Manual.



2.2 Carrier Frequency of Channels

Channel	Frequency (MHz)	Channel	Frequency (MHz)	Channel	Frequency (MHz)
*00	2402	14	2430	28	2458
01	2404	15	2432	29	2460
02	2406	16	2434	30	2462
03	2408	17	2436	31	2464
04	2410	18	2438	32	2466
05	2412	*19	2440	33	2468
06	2414	20	2442	34	2470
07	2416	21	2444	35	2472
08	2418	22	2446	36	2474
09	2420	23	2448	37	2476
10	2422	24	2450	38	2478
11	2424	25	2452	*39	2480
12	2426	26	2454	--	--
13	2428	27	2456	--	--

Note: Channels remarked * are selected to perform test.

2.3 Test Mode and Test Software

- a. During testing, the interface cables and equipment positions were varied according to ANSI C63.10.
- b. The complete test system included support units and EUT for RF test.
- c. Run the test software "IPOP4.1.exe (Ver.: 4.1.0.0)" under Win 10 System was executed to transmit and receive data via Bluetooth.
- d. The following test modes were performed for the test:

Conducted Emissions from the AC mains power ports	
Test Mode	Operating Description
Mode 1	GFSK (1Mbps) for AC120V
Mode 2	GFSK (1Mbps) for AC240V
caused "Test Mode 1 at CH00:2402" generated the worst case, it was reported as the final data.	
Radiation Emissions (Below 1GHz)	
Test Mode	Operating Description
Mode 1	GFSK (1Mbps)
caused "Test Mode 1 at CH00:2402" generated the worst case, they were reported as the final data.	
Radiation Emissions (1GHz ~ 25GHz)	
Test Mode	Operating Description
1	GFSK (1Mbps)
caused "Test Mode 1" generated the worst case, they were reported as the final data.	



2.4 Power Parameter Value of the test software

Mode	Frequency (MHz)	Power Setting
GFSK (1Mbps)	2402	Default
	2440	Default
	2480	Default

2.5 Description of Test System

Product	Manufacturer	Model No.	Serial No.	Power Cord
1 Notebook	SONY	PCG-71811P	27544574 7000251	Non-Shielded, 1.8m
2 Adapter	Xiaomi	MDY-12-ES	N/A	N/A

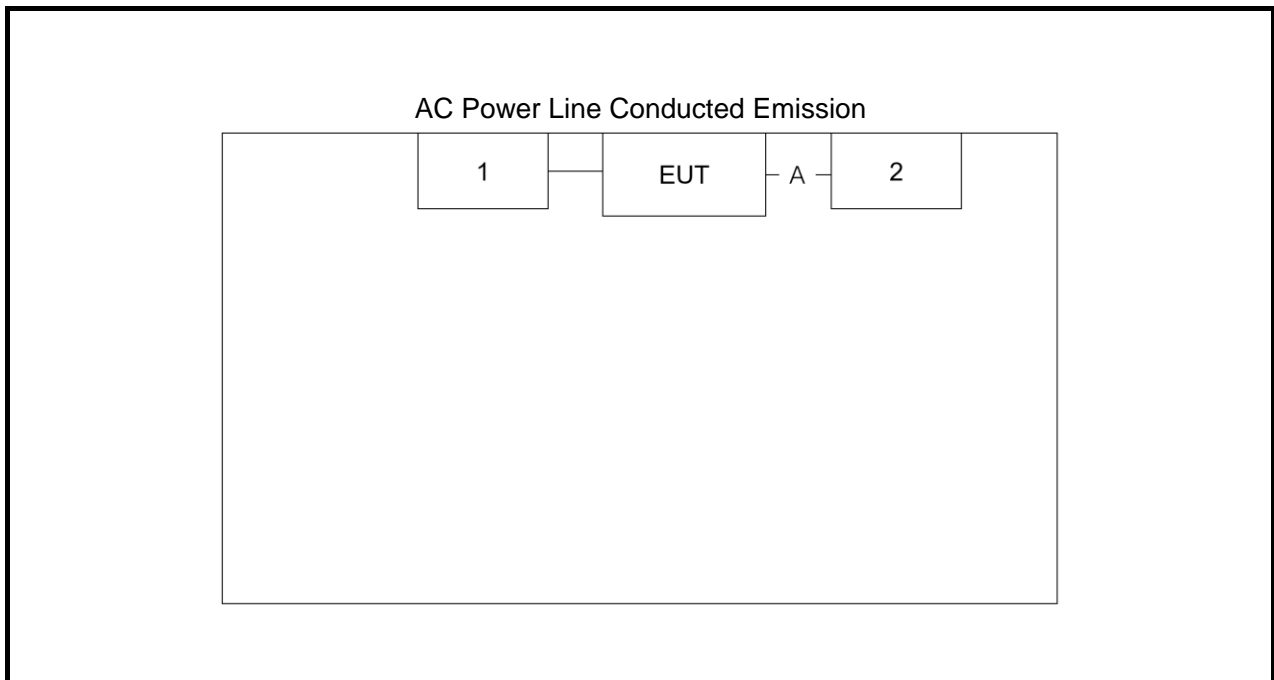

Signal Cable Type	Quantity	Signal cable Description
A USB charging cable	1	1.0m Non-Shielding

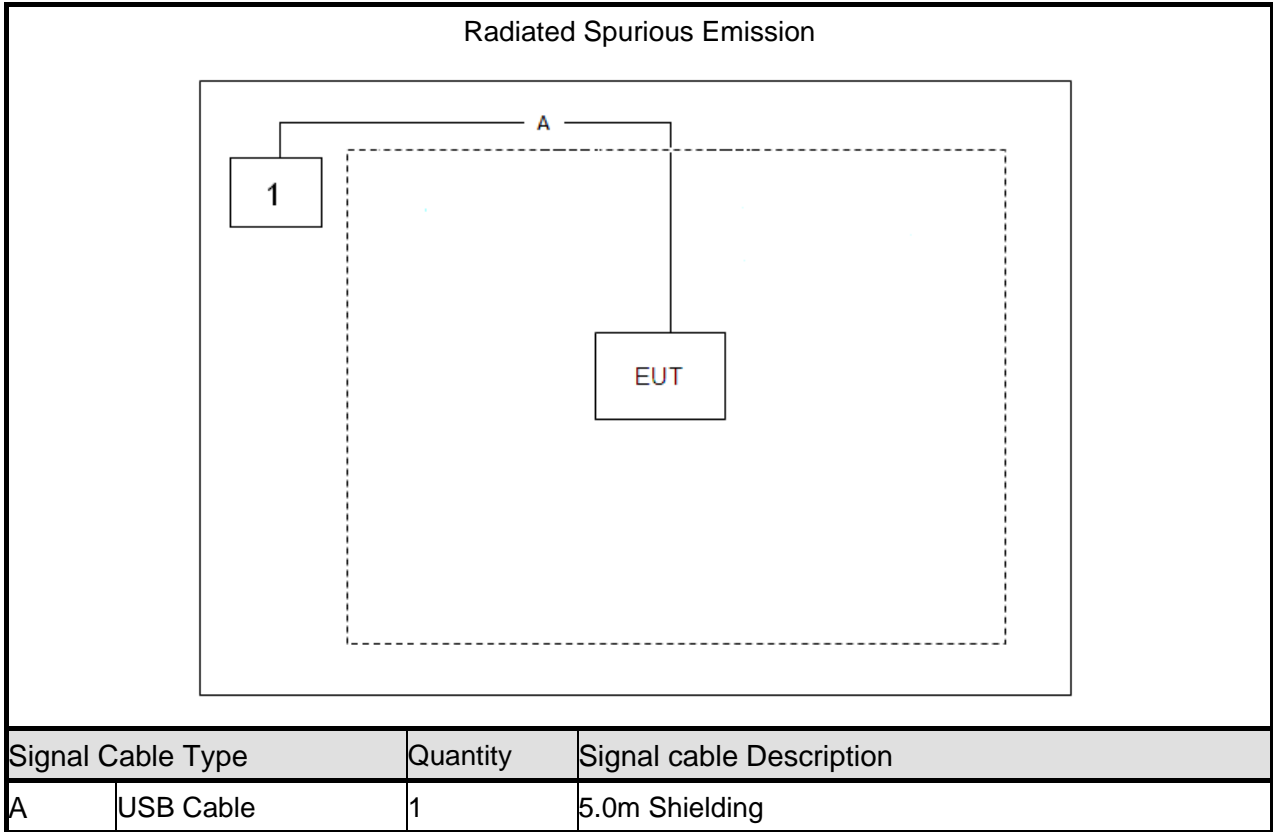



2.6 General Information of Test

Test Site	CerpPASS Technology Corporation(CerpPASS Laboratory) Address: Room 102, No. 5, Xing'an Road, Chang'an Town, Dongguan City, Guangdong Province Tel: +86-769-8547-1212 Fax: +86-769-8547-1912
FCC Designation No.:	CN1288
Frequency Range Investigated:	Conducted: from 150kHz to 30 MHz Radiation: from 9KHz to 25,000MHz
Test Distance:	The test distance of radiated emission from antenna to EUT is 3 M.

Test Item	Test Site	Test period	Environmental Conditions	Tested By
RF Conducted	RFCON01-DG	2023/06/06	25°C / 53%	Amos Zhang
Radiated Emissions	3M01-DG	2023/06/01~2023/06/02	22~24°C / 51~53%	Amos Zhang
AC Power Line Conducted Emission	CON01-DG	2023/6/02	23°C / 54%	Amos Zhang

2.7 Measurement Uncertainty

ISO/IEC 17025 requires that an estimate of the measurement uncertainties associated with the emissions test results be included in the report. The measurement uncertainties given below are based on a 95% confidence level (based on a coverage factor (k=2)).

Measurement Item	Uncertainty
AC Power Line Conduction(150K~30MHz)	±2.60dB
Radiated Spurious Emission(9KHz~30MHz)	±4.99dB
Radiated Spurious Emission(30MHz~1GHz)	±4.39dB
Radiated Spurious Emission(1GHz~18GHz)	±5.36dB
Radiated Spurious Emission(18GHz~40GHz)	±5.43dB
6dB Bandwidth&20dB Bandwidth	±4.8%
Occupied Bandwidth	±4.5%
Peak Output Power(Conducted Power Meter)	±0.94dB
Power Spectral Density	±1.01dB
Dwell Time / Deactivation Time	±3.5%



3. Test Equipment and Ancillaries Used for Tests

AC Power Line Conducted Emission					
Test Site	CON01-DG				
Instrument/Ancillary	Manufacturer	Model No.	Serial No.	Calibration Date	Valid Date.
Test Receiver	R&S	ESCI	100564	2023.01.06	2024.01.05
LISN	SCHWARZBECK	NSLK 8127	8127748	2023.01.06	2024.01.05
LISN	R&S	ENV216	100024	2023.01.06	2024.01.05
ISN	TESEQ	ISN T800	42809	2023.05.06	2024.05.05
Pulse Limiter with 10dB Attenuation	SCHWARZBECK	VTSD 9561-F	9561-F106	2023.01.06	2024.01.05
Temperature/ Humidity Meter	GEMLEAD	STH200A	N/A	2022.08.05	2023.08.04

Radiated Emissions					
Test Site	3M01-DG				
Instrument	Manufacturer	Model No.	Serial No.	Calibration Date	Valid Date
EMI Test Receiver	R&S	ESCI	100565	2023.05.06	2024.05.05
Amplifier	EMCI	EMC330	980082	2023.05.06	2024.05.05
Loop Antenna	R&S	HFH2-Z2	100150	2022.05.11	2024.05.10
Bilog Antenna	Sunol Science	JB6	A111218	2023.01.12	2025.01.11
Preamplifier	Agilent	8449B	3008A02342	2023.01.06	2024.01.05
Preamplifier	COM-POWER	PA-840	711885	2023.05.06	2024.05.05
Broad-Band Horn Antenna	Schwarzbeck	BBHA9120D	9120D-619	2022.05.22	2024.05.21
Standard Gain Horn Antenna	TRC	HA-2640	18050	2022.05.09	2024.05.08
Standard Gain Horn Antenna	TRC	HA-1726	18051	2022.05.09	2024.05.08
FSQ Signal Analyzer	R&S	FSQ40	200012	2023.05.06	2024.05.05
Temperature/ Humidity Meter	GEMLEAD	STH200A	N/A	2022.08.05	2023.08.04



RF Conducted					
Test Site	RFCON01-DG				
Instrument	Manufacturer	Model No.	Serial No.	Calibration Date	Valid Date
MXA Signal Analyzer	KEYSIGHT	N9020A	US46220290	2023.05.06	2024.05.05
EXA Signal Analyzer	KEYSIGHT	N9010A	MY53400169	2023.05.06	2024.05.05
ESG VECTOR SIGNAL GENERATOR	Agilent	E4438C	MY45092582	2023.05.06	2024.05.05
MXG VECTOR SIGNAL GENERATOR	Agilent	N5182B	MY53050127	2023.05.06	2024.05.05
USB Wideband Power Sensor	Boonton	55006	9778	2023.01.06	2024.01.05
Temperature/ Humidity Meter	mingle	ETH529	N/A	2023.01.06	2024.01.05



4. Antenna Requirements

4.1 Standard Applicable

For intentional device, according to FCC 47 CFR Section 15.203, an intentional radiator shall be designed to ensure that no antenna other than that furnished by the responsible party shall be used with the device.

And according to FCC 47 CFR Section 15.247 (b), if transmitting antennas of directional gain greater than 6dBi are used, the power shall be reduced by the amount in dB that the directional gain of the antenna exceeds 6dBi.

4.2 Antenna Construction and Directional Gain

Antenna Type	PCB
Antenna Gain	0.5dBi



5. Test of Conducted Emission

5.1 Test Limit

Conducted Emissions were measured from 150 kHz to 30 MHz with a bandwidth of 9 KHz on the 120 VAC power and return leads of the EUT according to the methods defined in ANSI C63.10-2013. The EUT was placed on a nonmetallic stand in a shielded room 0.8 meters above the ground plane as shown in section 6.2.2. The interface cables and equipment positioning were varied within limits of reasonable applications to determine the position produced maximum conducted emissions

Frequency (MHz)	Quasi Peak (dB μ V)	Average (dB μ V)
0.15 – 0.5	66-56*	56-46*
0.5 – 5.0	56	46
5.0 – 30.0	60	50

*Decreases with the logarithm of the frequency.

5.2 Test Procedures

- a. The EUT was placed 0.4 meter from the conducting wall of the shielding room was kept at least 80 centimeters from any other grounded conducting surface.
- b. Connect EUT to the power mains through a line impedance stabilization network (LISN).
- c. All the support units are connecting to the other LISN.
- d. The LISN provides 50 ohm coupling impedance for the measuring instrument.
- e. The FCC states that a 50 ohm, 50 micro-Henry LISN should be used.
- f. Both sides of AC line were checked for maximum conducted interference.
- g. The frequency range from 150 kHz to 30 MHz was searched.
- h. Set the test-receiver system to Peak Detect Function and Specified Bandwidth with Maximum Hold Mode.



5.3 Typical Test Setup

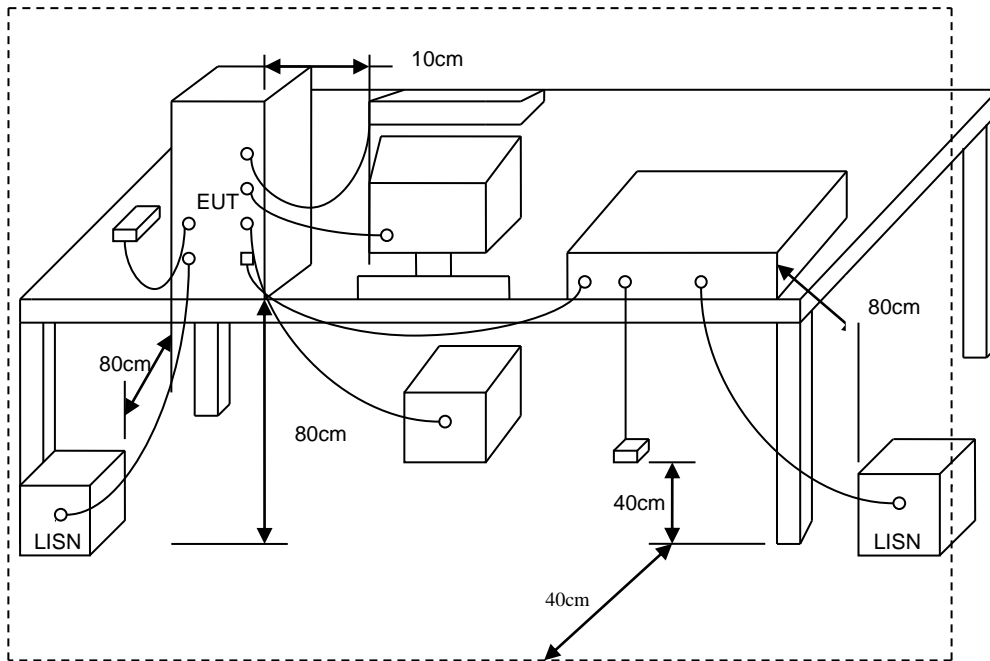



5.4 Test Result and Data

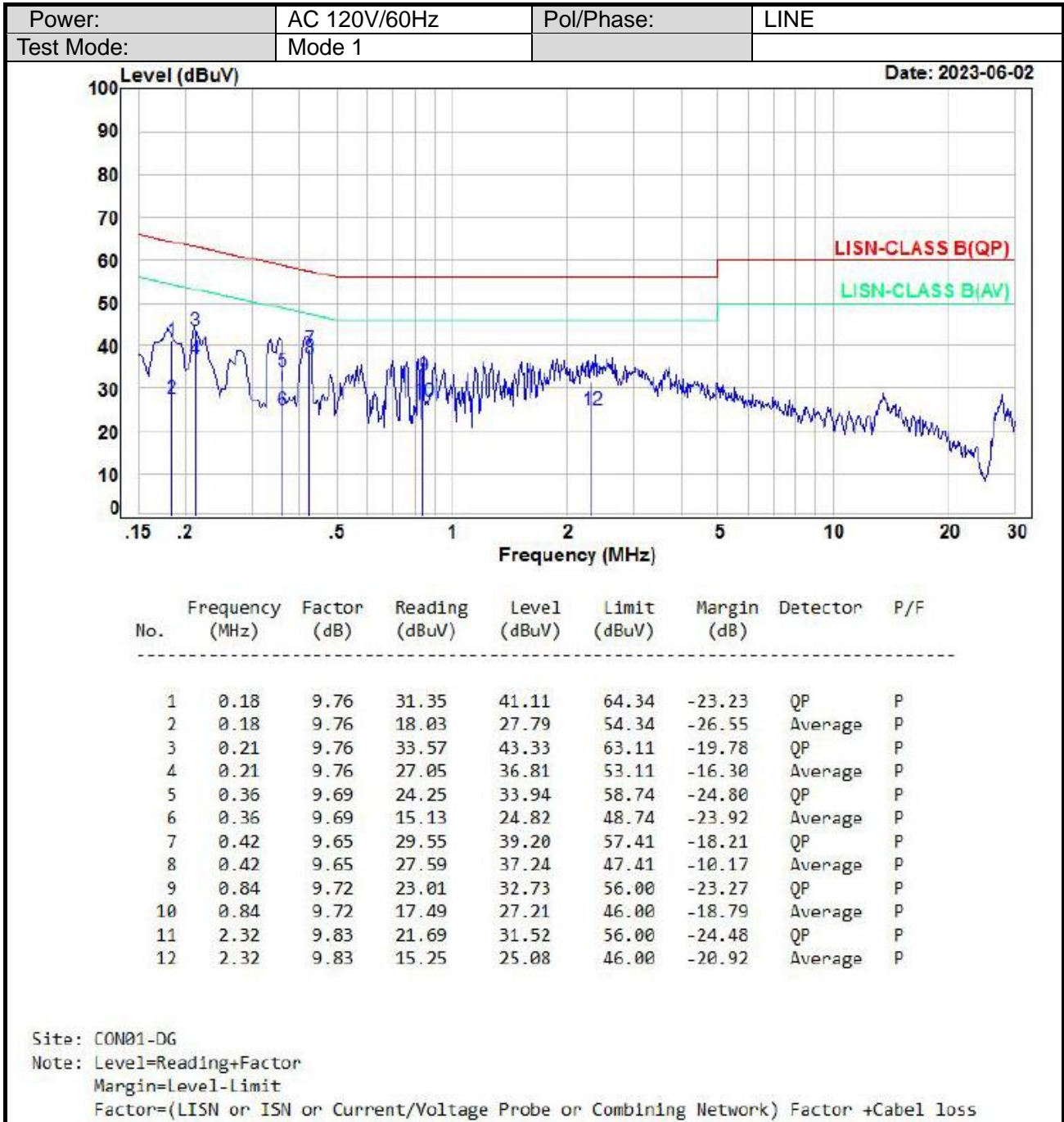

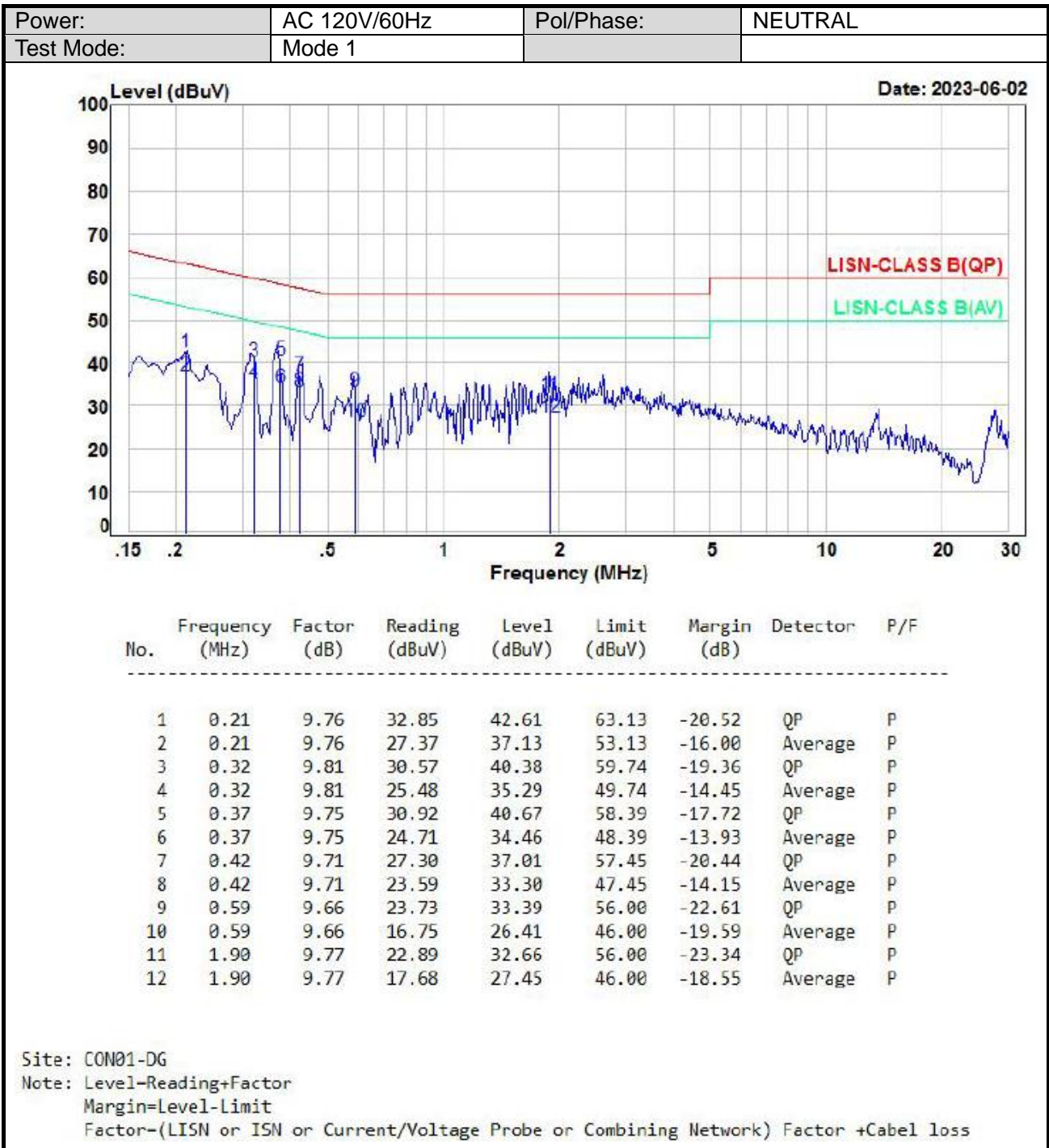



6. Test of Spurious Emission (Radiated)

6.1 Test Limit

In any 100kHz bandwidth outside the frequency band in which the spread spectrum or digitally modulated intentional radiator is operating, the radio frequency power that is produced by the intentional radiator shall be at least 20dB below that in the 100kHz bandwidth within the band that contains the highest level of the desired power, based on either an RF conducted or a radiated measurement. If the transmitter measurement is based on the maximum conducted output power, the attenuation required under this paragraph shall be 30dB instead of 20dB. In addition, radiated emissions which fall in section 15.205(a) the restricted bands must also comply with the radiated emission limit specified in section 15.209(a).

Frequency (MHz)	Field Strength (microvolt/meter)	Measurement Distance (meters)
0.009 ~ 0.490	2400/F(kHz)	300
0.490 ~ 1.705	24000/F(kHz)	30
1.705 ~ 30.0	30	30
30 ~ 88	100	3
88 ~ 216	150	3
216 ~ 960	200	3
Above 960	500	3

6.2 Test Procedures

- The EUT was placed on a rotatable table top 0.8 meter above ground.
- The EUT was set 3 meters from the interference receiving antenna which was mounted on the top of a variable height antenna tower.
- The table was rotated 360 degrees to determine the position of the highest radiation.
- The antenna is a broadband antenna and its height is varied between one meter and four meters above ground to find the maximum value of the field strength both horizontal polarization and vertical polarization of the antenna are set to make the measurement.
- For each suspected emission the EUT was arranged to its worst case and then tune the antenna tower (from 1 M to 4 M) and turn table (from 0 degree to 360 degrees) to find the maximum reading.
- Set the test-receiver system to Peak or CISPR quasi-peak Detect Function and specified bandwidth with Maximum Hold Mode.
- If the emission level of the EUT in peak mode was 3 dB lower than the limit specified, then testing will be stopped and peak values of EUT will be reported, otherwise, the emissions which do not have 3 dB margin will be repeated one by one using the quasi-peak method and reported.
- For testing above 1GHz, the emission level of the EUT in peak mode was 20dB lower than average limit (that means the emission level in peak mode also complies with the limit in average mode), then testing will be stopped and peak values of EUT will be reported, otherwise, the emissions will be measured in average mode again and reported.
- "Cone of radiation" has been considered to be 3dB bandwidth of the measurement antenna.

Note: The supporting fixture shall permit orientation of the EUT in each of three orthogonal axis positions such that emissions from the EUT are maximized.(X AXIS is the worst.)



6.3 Typical Test Setup

Below 30MHz test setup

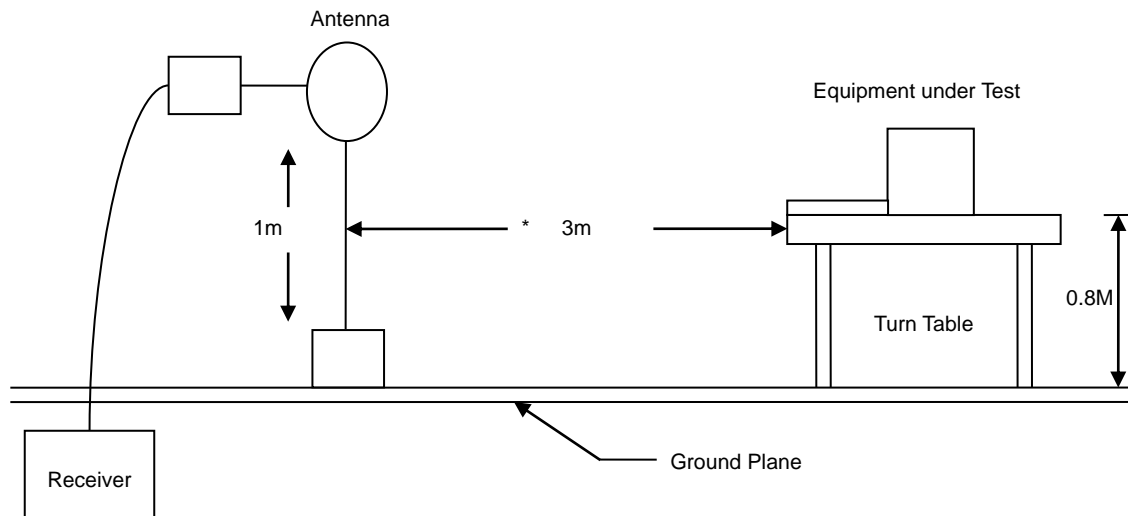

30MHz- 1GHz Test Setup

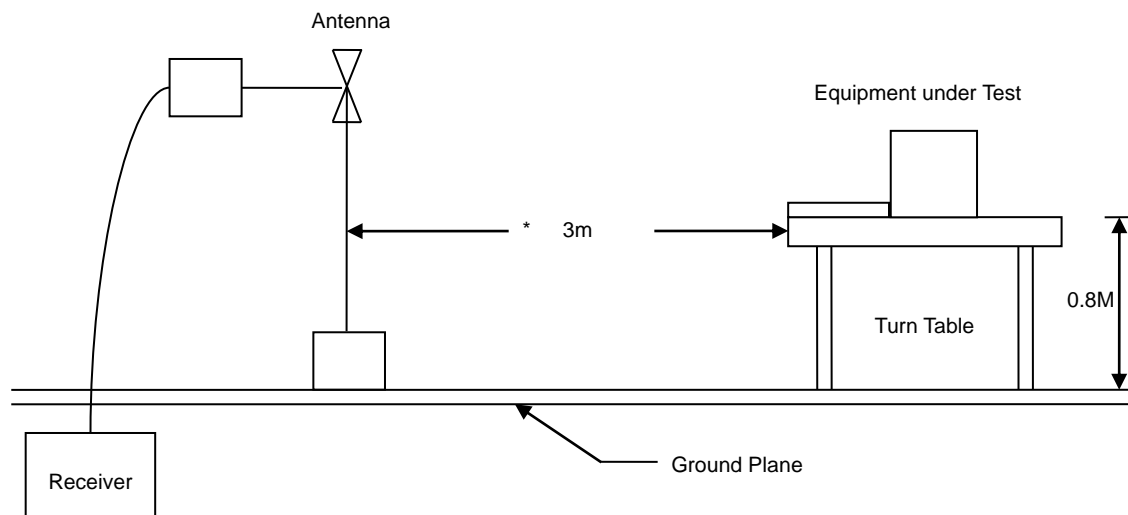

Above 1GHz Test Setup

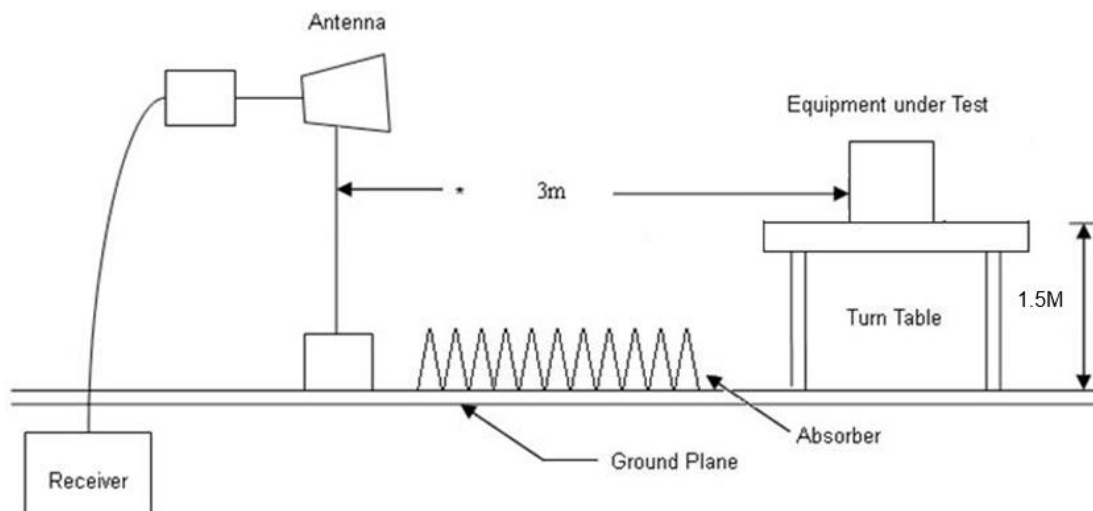



6.4 Test Result and Data (9kHz ~ 30MHz)

The 9kHz - 30MHz spurious emission is under limit 20dB more.

6.5 Test Result and Data (30MHz ~ 1GHz)

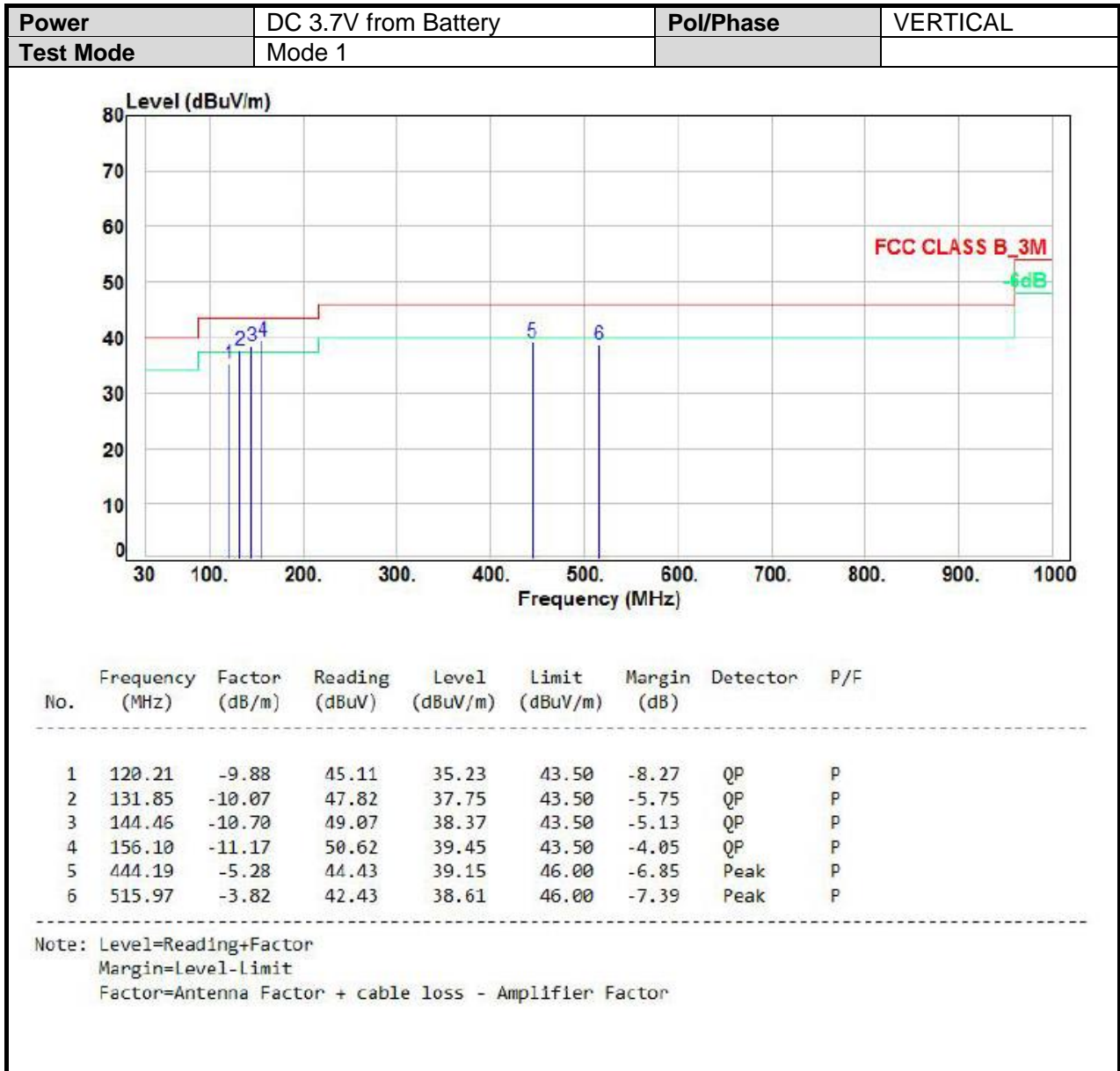





6.6 Test Result and Data (1GHz ~ 25GHz)

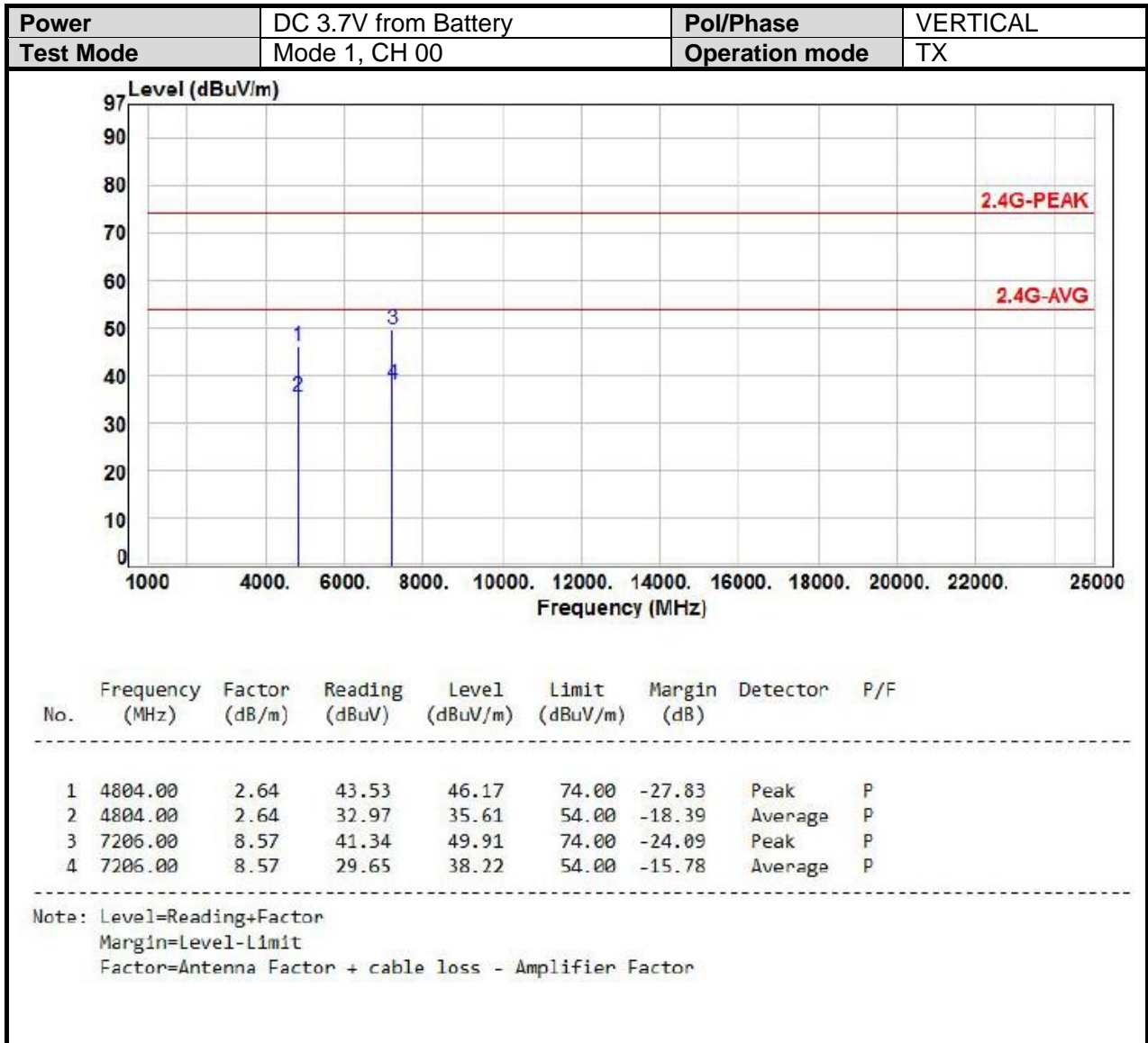

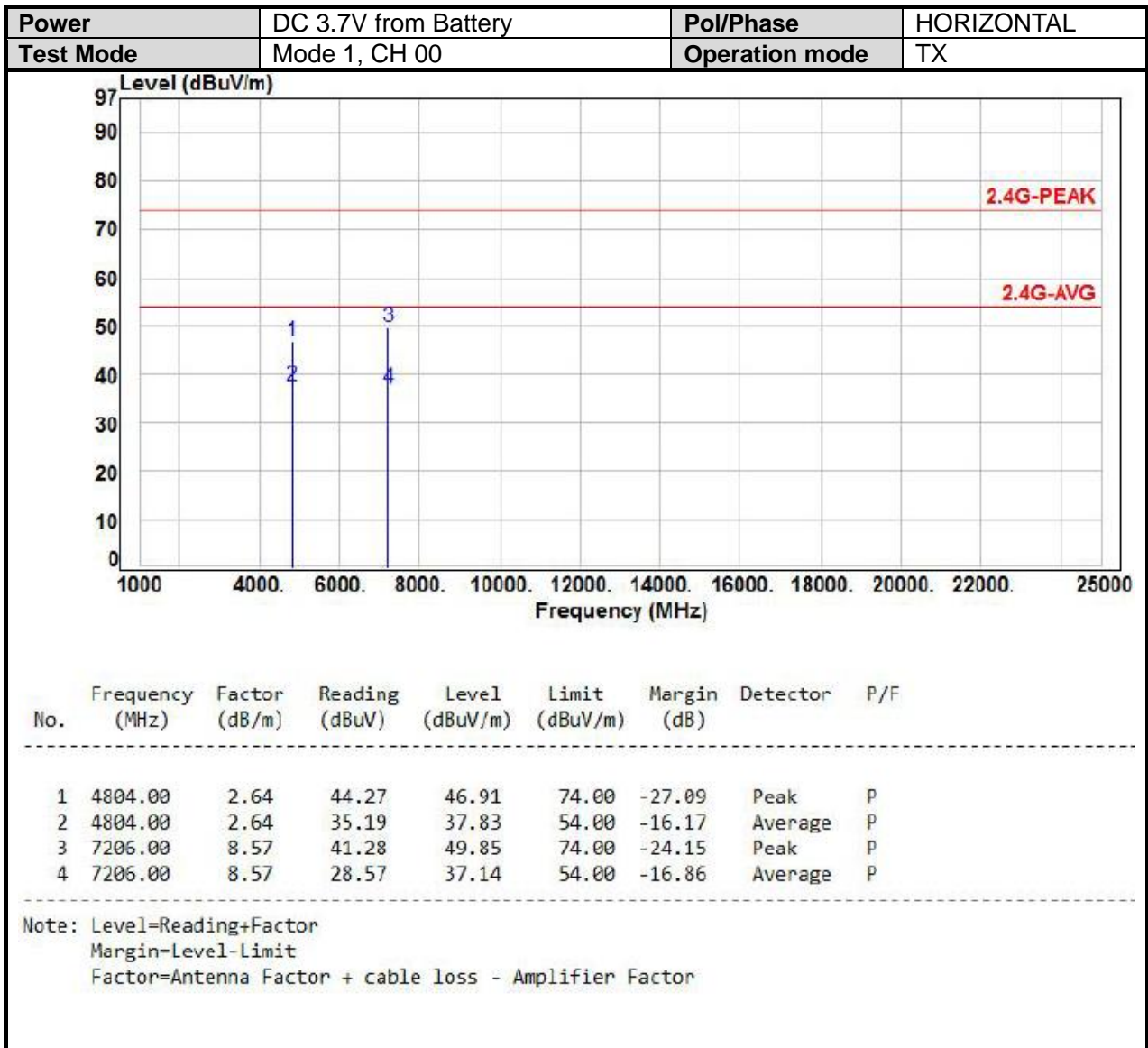

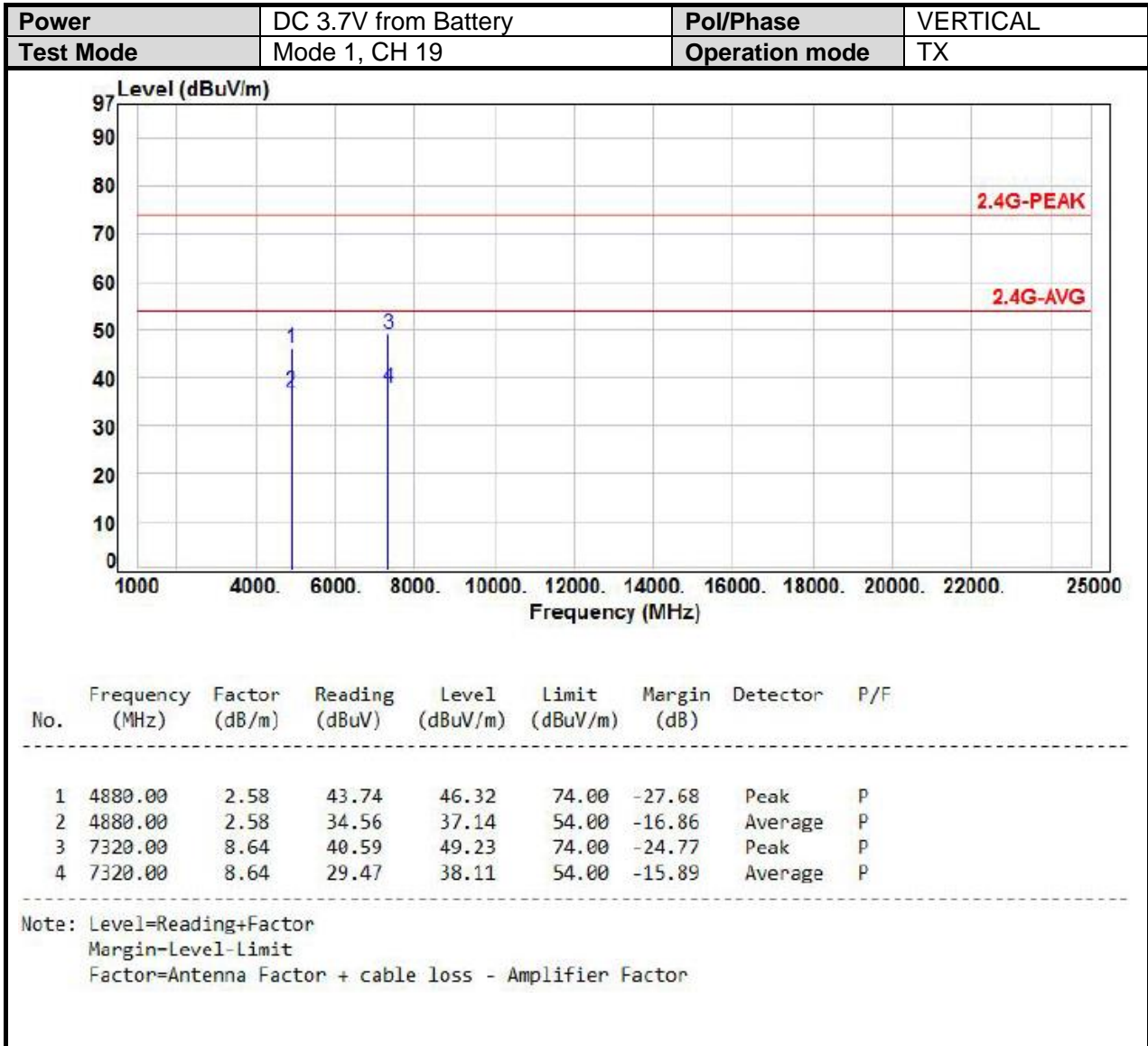

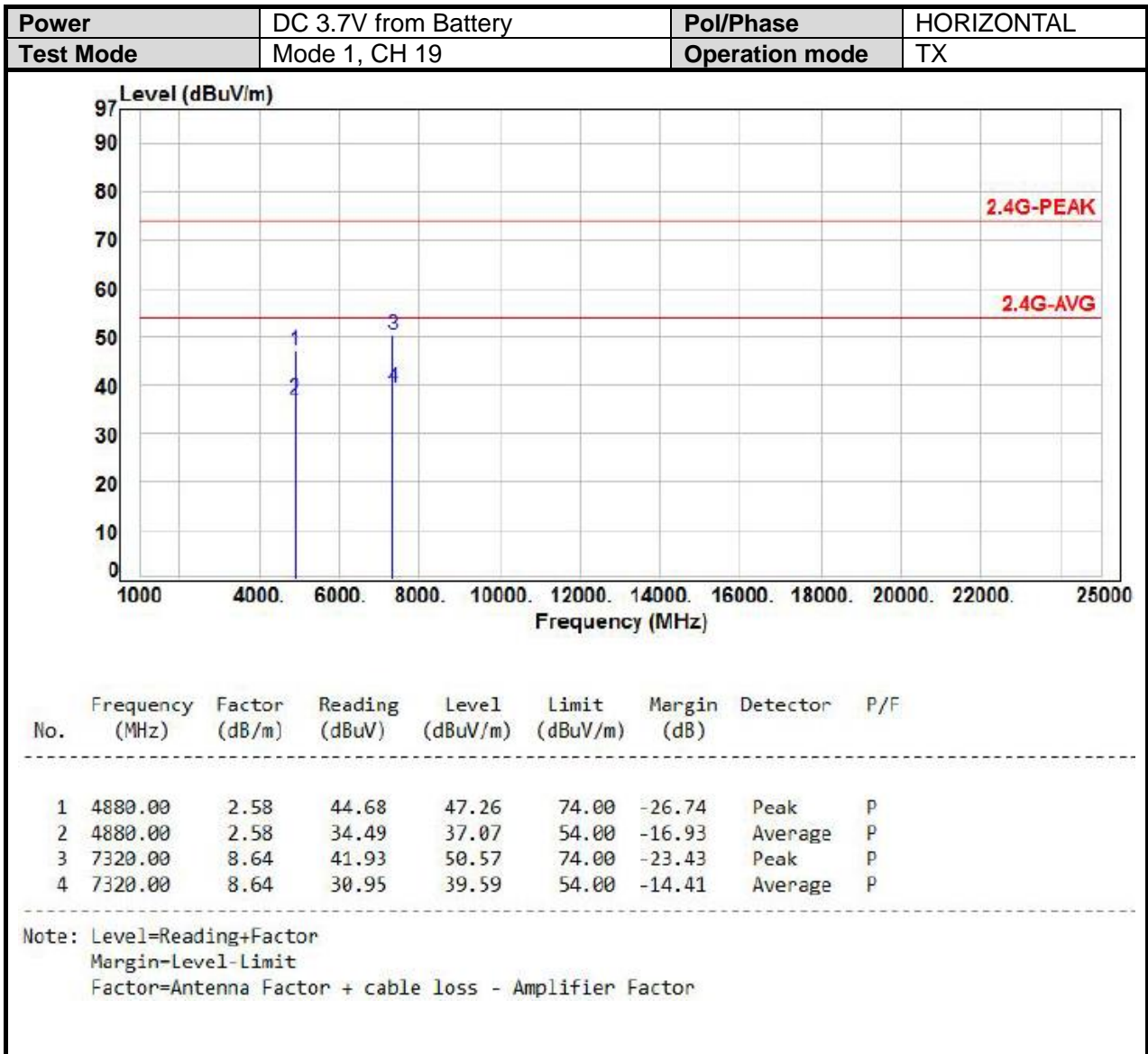

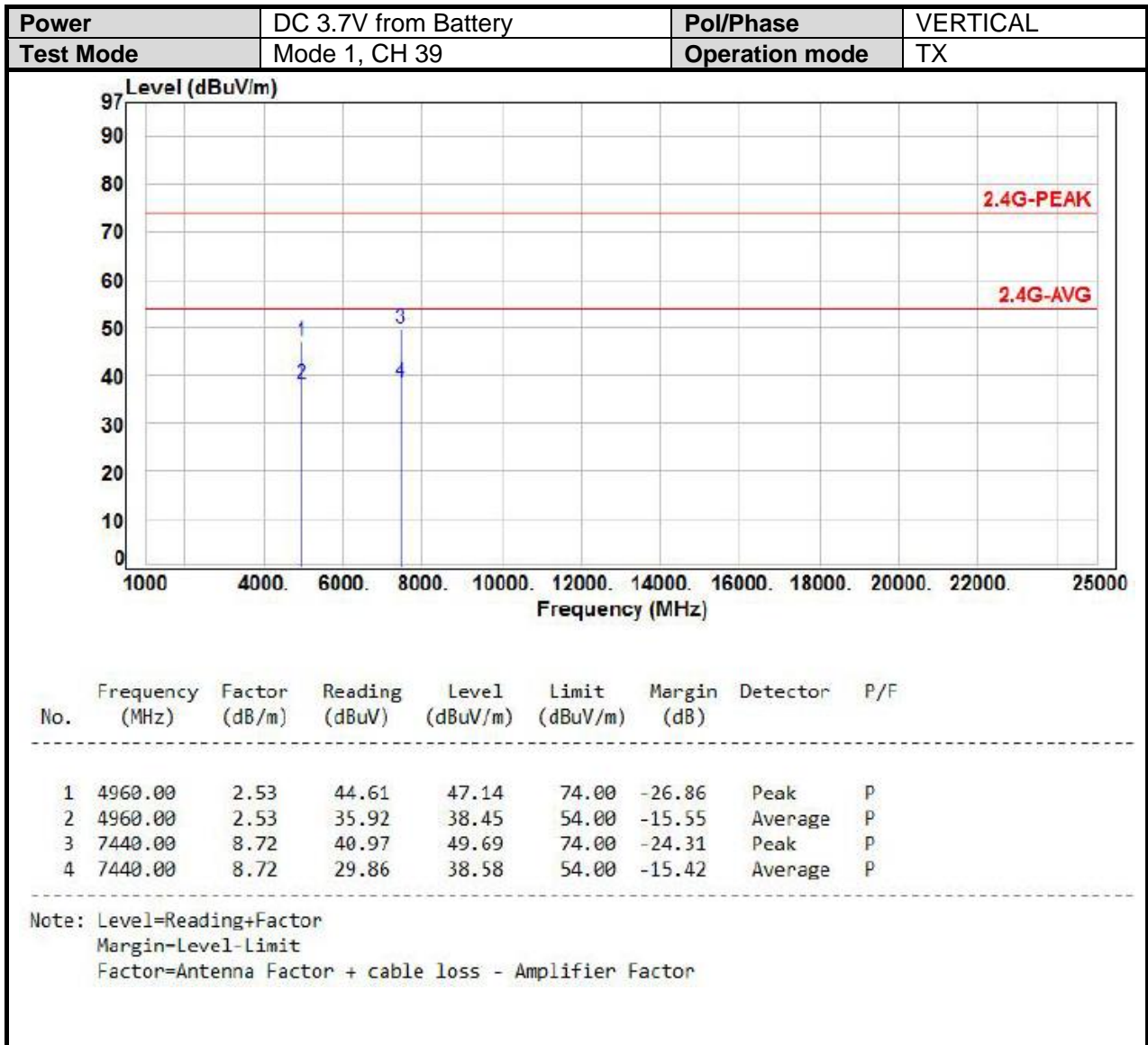

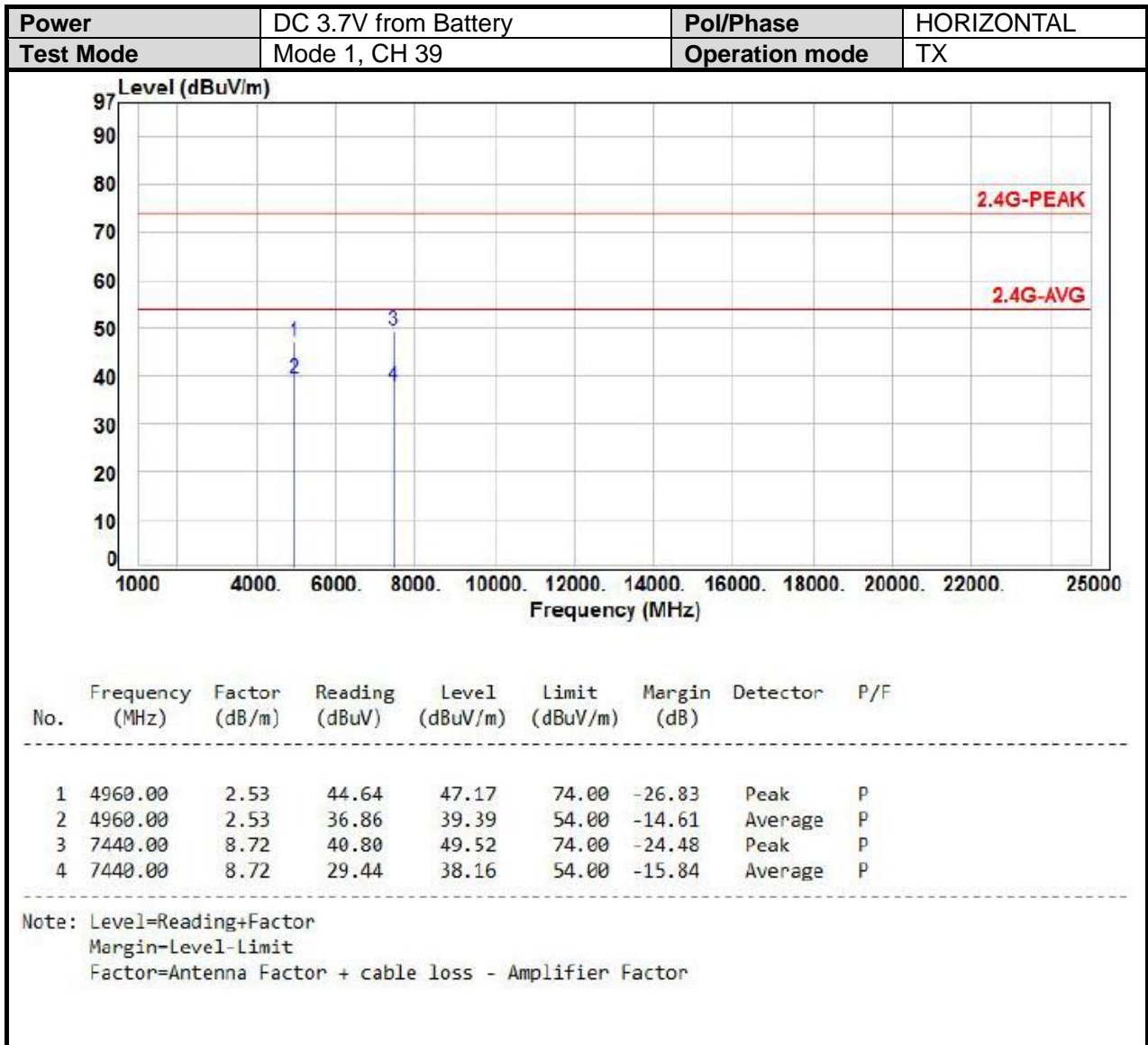



6.7 Restricted Bands of Operation

Only spurious emissions are permitted in any of the frequency bands listed below:

MHz	MHz	MHz	GHz
0.09000 – 0.11000	16.42000 – 16.42300	399.9 – 410.0	4.500 – 5.250
0.49500 – 0.505**	16.69475 – 16.69525	608.0 – 614.0	5.350 – 5.460
2.17350 – 2.19050	16.80425 – 16.80475	960.0 – 1240.0	7.250 – 7.750
4.12500 – 4.12800	25.50000 – 25.67000	1300.0 – 1427.0	8.025 – 8.500
4.17725 – 4.17775	37.50000 – 38.25000	1435.0 – 1626.5	9.000 – 9.200
4.20725 – 4.20775	73.00000 – 74.60000	1645.5 – 1646.5	9.300 – 9.500
6.21500 – 6.21800	74.80000 – 75.20000	1660.0 – 1710.0	10.600 – 12.700
6.26775 – 6.26825	108.00000 – 121.94000	1718.8 – 1722.2	13.250 – 13.400
6.31175 – 6.31225	123.00000 – 138.00000	2200.0 – 2300.0	14.470 – 14.500
8.29100 – 8.29400	149.90000 – 150.05000	2310.0 – 2390.0	15.350 – 16.200
8.36200 – 8.36600	156.52475 – 156.52525	2483.5 – 2500.0	17.700 – 21.400
8.37625 – 8.38675	156.70000 – 156.90000	2655.0 – 2900.0	22.010 – 23.120
8.41425 – 8.41475	162.01250 – 167.17000	3260.0 – 3267.0	23.600 – 24.000
12.29000 – 12.29300	167.72000 – 173.20000	3332.0 – 3339.0	31.200 – 31.800
12.51975 – 12.52025	240.00000 – 285.00000	3345.8 – 3358.0	36.430 – 36.500
12.57675 – 12.57725	322.00000 – 335.40000	3600.0 – 4400.0	Above 38.6
13.36000 – 13.41000			

** : Until February 1, 1999, this restricted band shall be 0.490-0.510 MHz



6.8 Restrict Band Emission Measurement Data

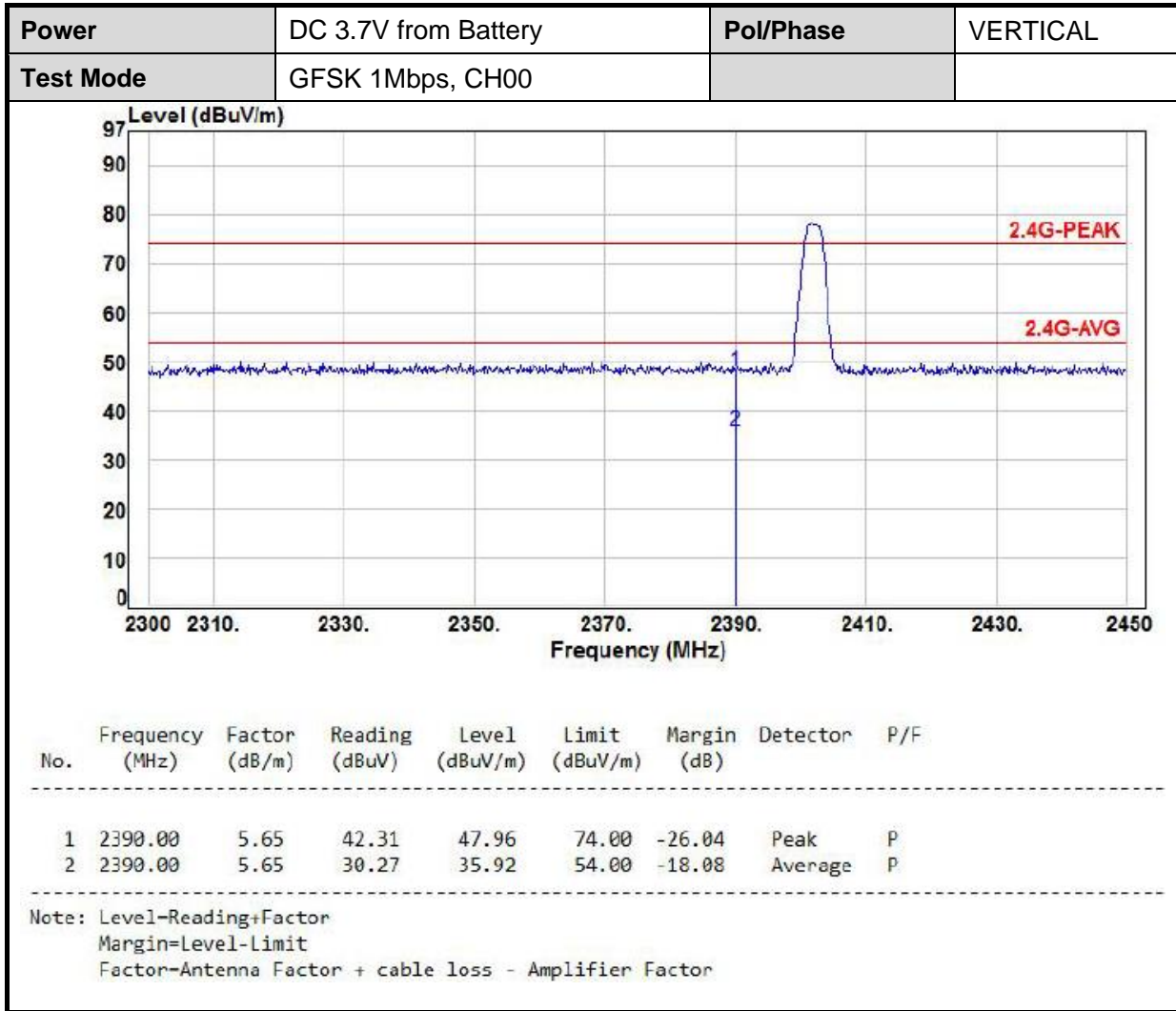

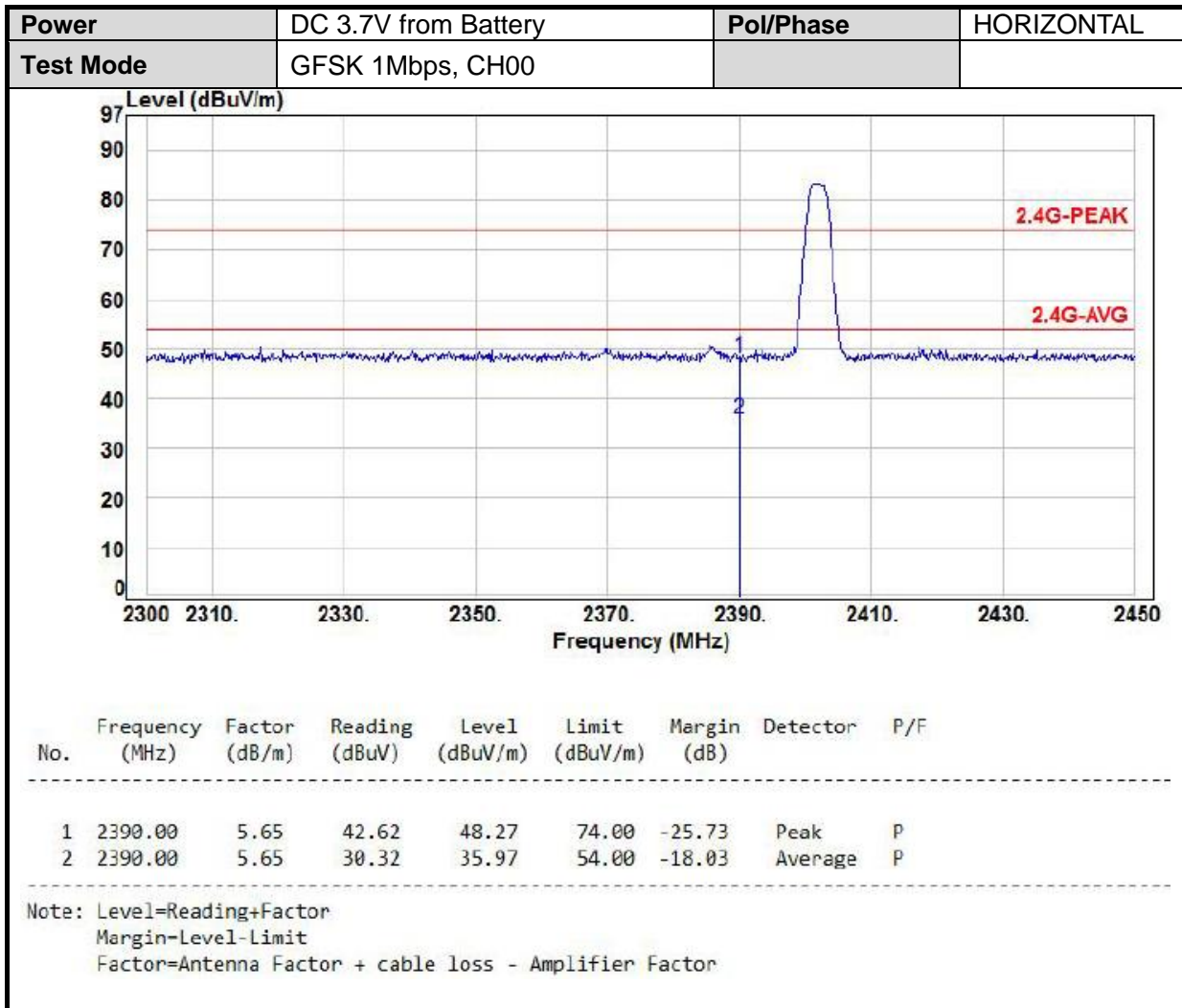

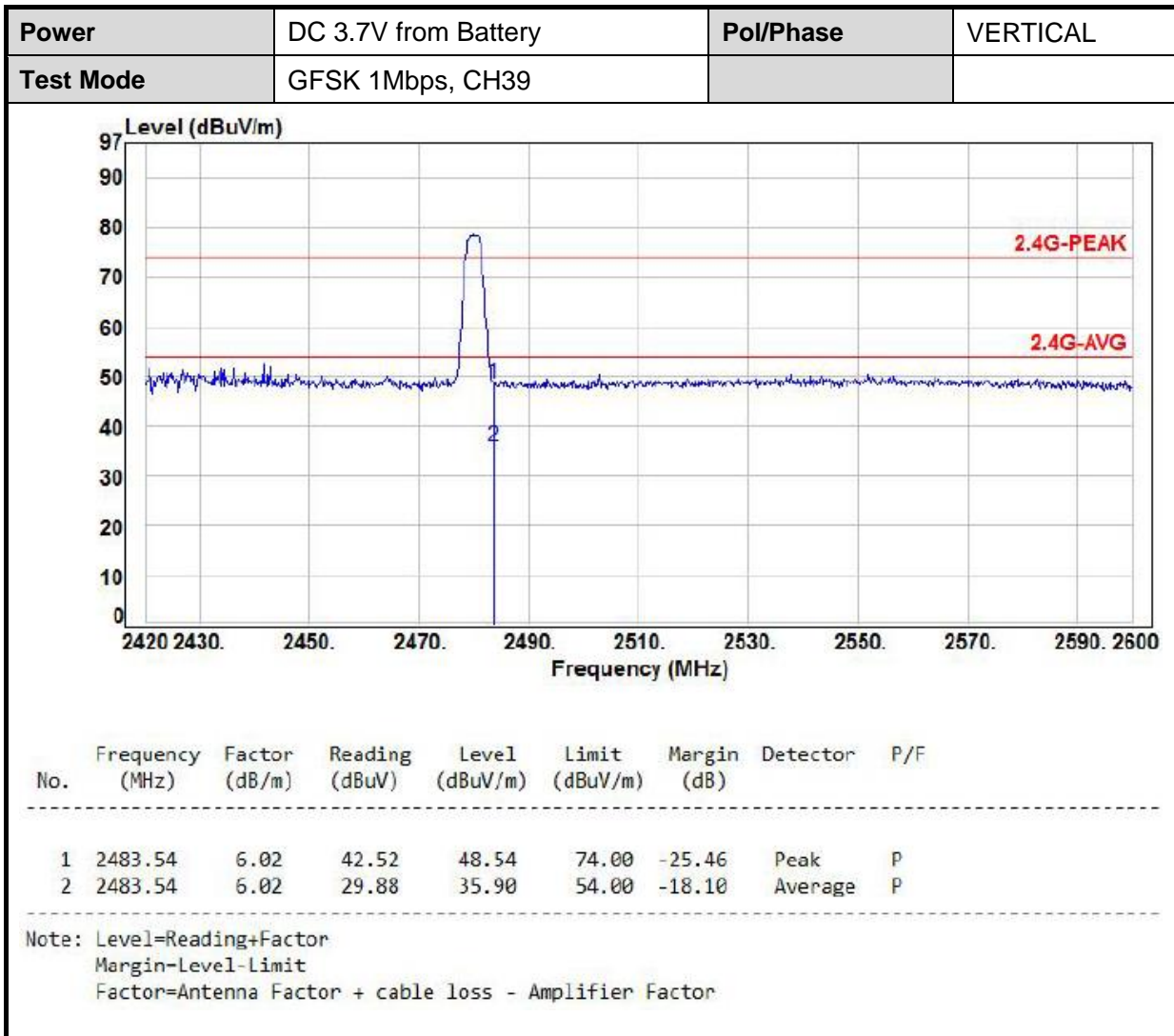

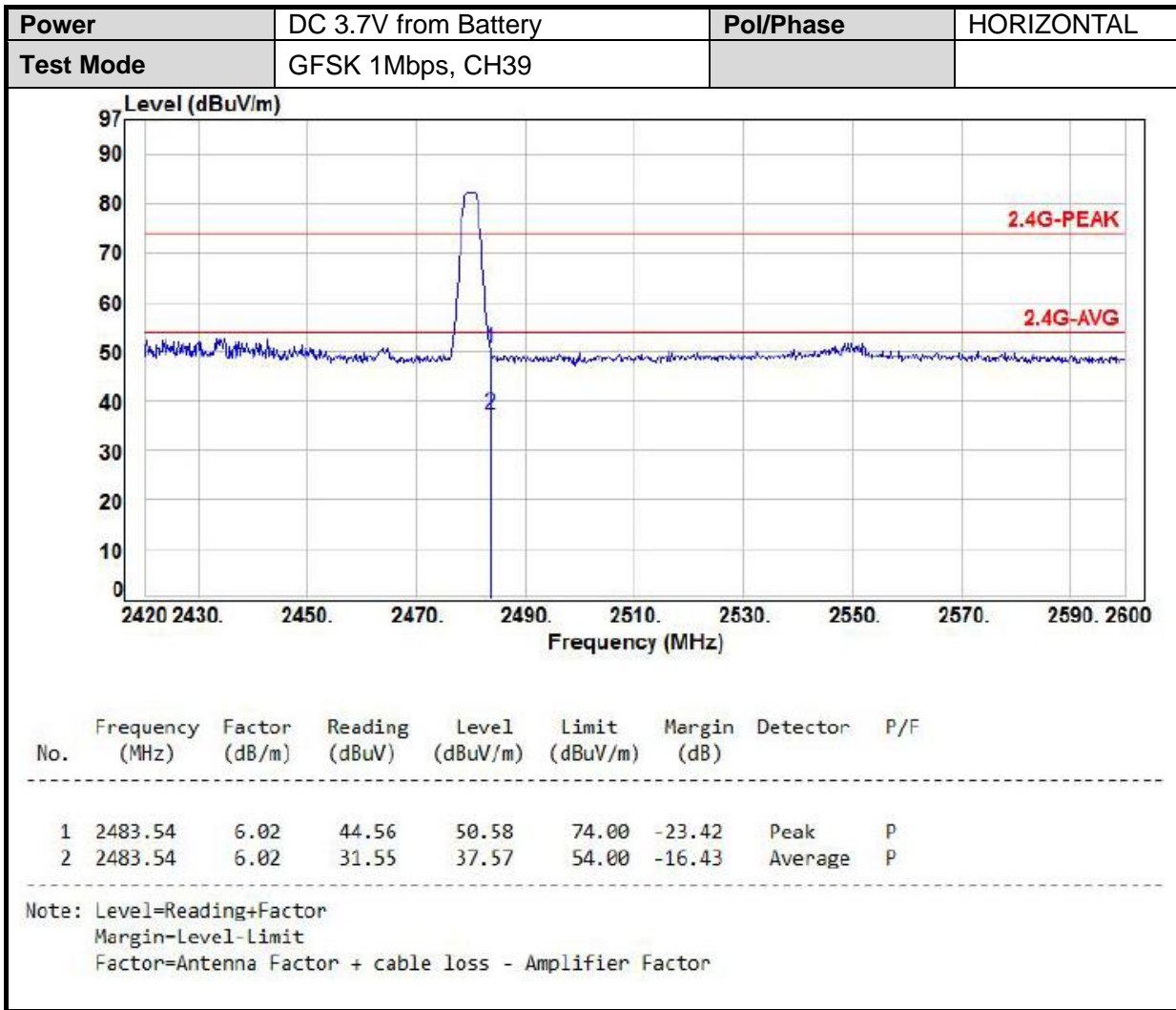



7. Test of Spurious Emission (Conducted)

7.1 Test Limit

Below -20dB of the highest emission level of operating band (In 100 kHz Resolution Bandwidth)

7.2 Test Procedure

- a. The transmitter output was connected to the spectrum analyzer via a low loss cable.
- b. Set RBW of spectrum analyzer to 100 KHz and VBW of spectrum analyzer to 300 KHz with convenient frequency span including 100 KHz bandwidth from band edge.
- c. Peak conducted output power measured within any 100 kHz outside the authorized frequency band shall be attenuated by at least 20dB relative to the maximum measured in-band peak PSD level.
- d. The band edges was measured and recorded.

7.3 Test Setup Layout

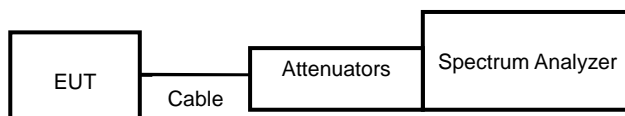

7.4 Test Result and Data

Note: Test plots refer to the following pages.



Modulation Type: GFSK 1Mbps
CH00

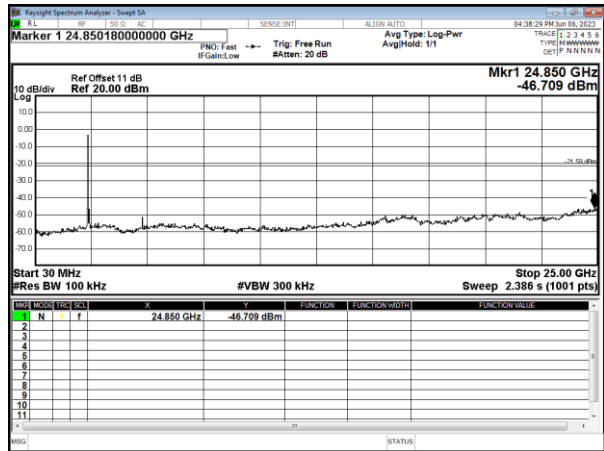
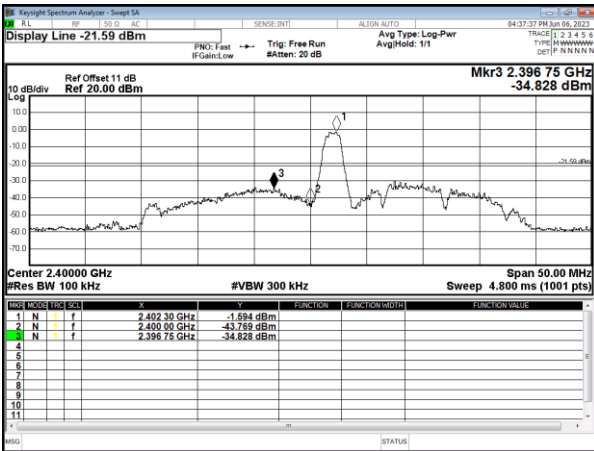

Modulation Type: GFSK 1Mbps
CH19

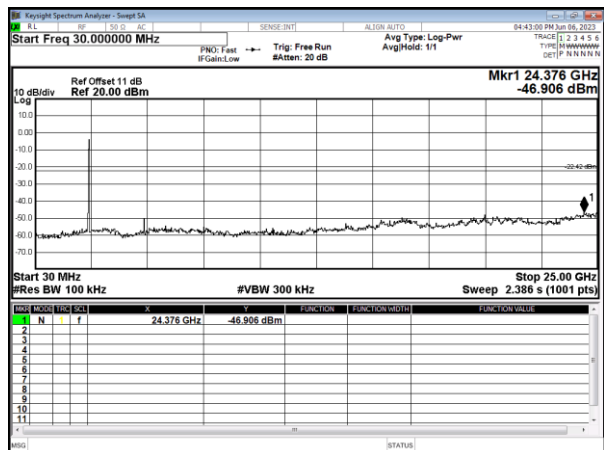
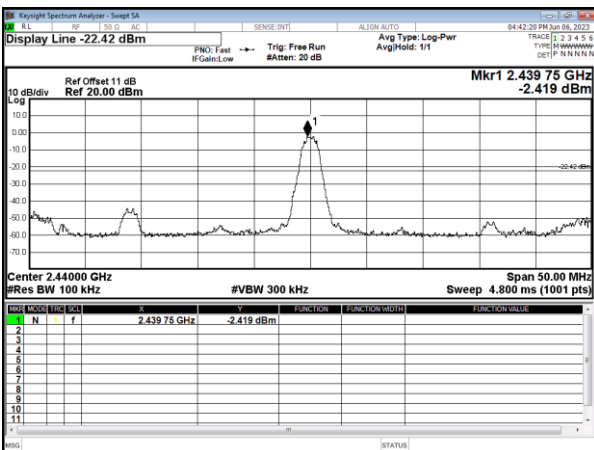

Modulation Type: GFSK 1Mbps
CH39

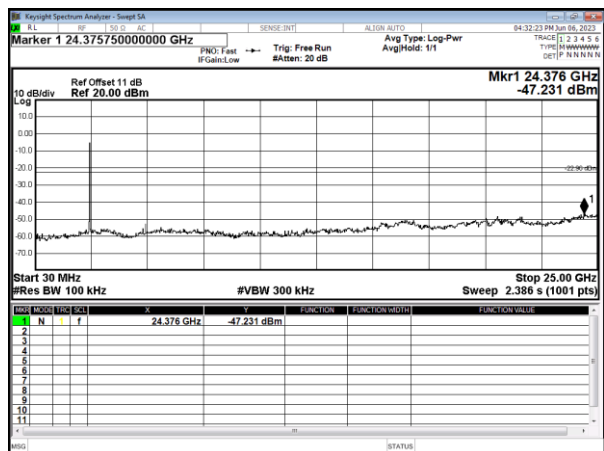
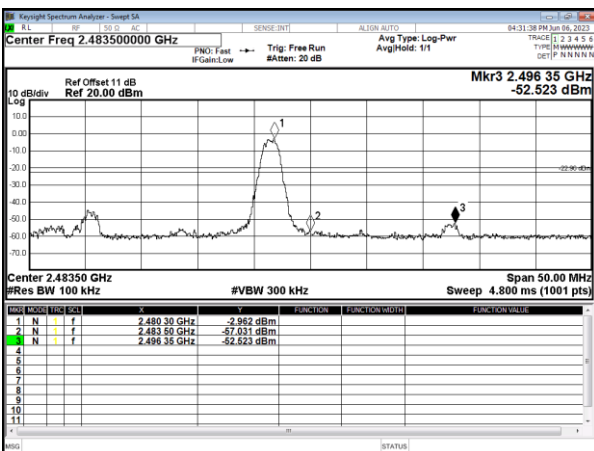



8. On Time, Duty Cycle and Measurement methods

8.1 Test Limit

None; for reporting purposes only.

8.2 Test Procedure

Zero-Span Spectrum Analyzer Method.

8.3 Test Setup Layout

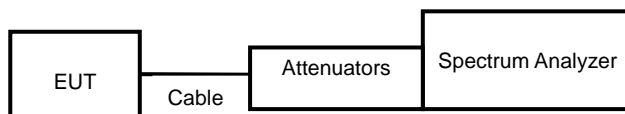

8.4 Test Result and Data

Modulation Type	On Time (msec)	Period Time (msec)	Duty Cycle (%)
GFSK (1Mbps)	100.000	100.000	100.00%

Note: Test plots refer to the following pages.



Modulation Type: GFSK 1Mbps

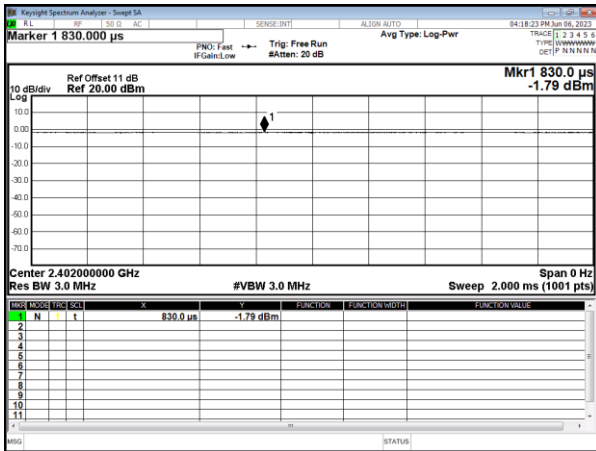



9. 6dB Bandwidth Measurement Data

9.1 Test Limit

The minimum of 6dB Bandwidth Measurement is 0.5 MHz.

9.2 Test Procedures

- a. The transmitter output was connected to the spectrum analyzer.
- b. Set RBW of spectrum analyzer to 1~5% of the emission bandwidth and VBW \geq 3x RBW.
- c. The 6 dB bandwidth is defined as the total spectrum the power of which is higher than peak power minus 6 dB.
- d. The 6dB Bandwidth was measured and recorded.

9.3 Test Setup Layout

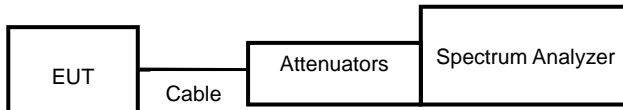

9.4 Test Result and Data

Modulation Type	Channel	Frequency (MHz)	6dB Bandwidth (KHz)	Limit (KHz)
GFSK (1Mbps)	00	2402	1321.00	500
	19	2440	1318.00	500
	39	2480	1312.00	500



Modulation Standard: GFSK (1Mbps)
Channel: 00

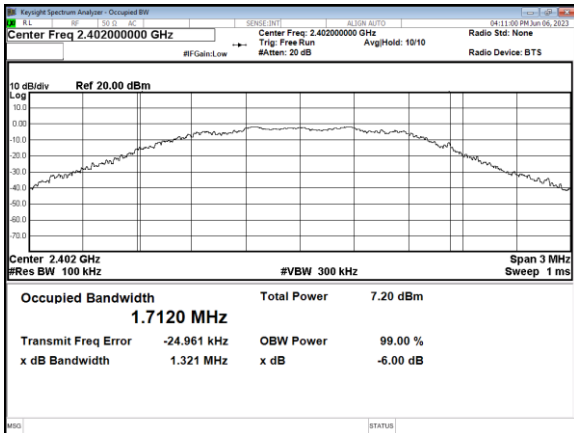

Modulation Standard: GFSK (1Mbps)
Channel: 19

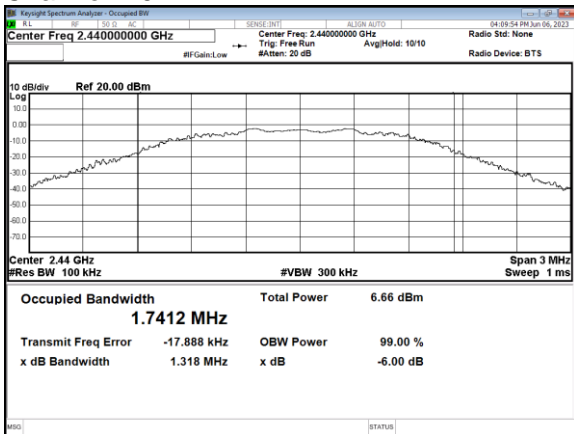

Modulation Standard: GFSK (1Mbps)
Channel: 39

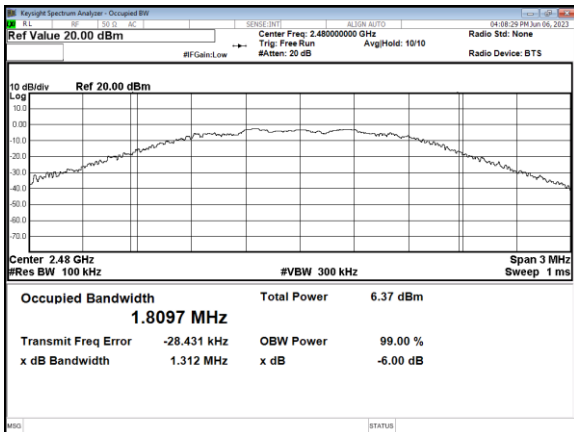



10. Maximum Peak Output Power

10.1 Test Limit

The Maximum Peak Output Power Measurement is 30dBm.

10.2 Test Procedures

The antenna port (RF output) of the EUT was connected to the input (RF input) of a power meter. Power was read directly from the meter and cable loss connection was added to the reading to obtain power at the EUT antenna terminal. The EUT Output Power was set to maximum to produce the worse case test result.

10.3 Test Setup Layout

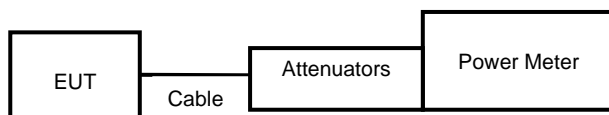

10.4 Test Result and Data

Modulation Standard	Channel	Frequency (MHz)	Power Output (dBm)	Peak Power Output (mW)
GFSK (1Mbps)	00	2402	0.850	1.216
	19	2440	0.380	1.091
	39	2480	0.150	1.035



11. Power Spectral Density

11.1 Test Limit

The Maximum of Power Spectral Density Measurement is 8dBm.

11.2 Test Procedures

- a. The transmitter output was connected to spectrum analyzer.
- b. The spectrum analyzer's resolution bandwidth were set at 3KHz RBW and 10KHz VBW as that of the fundamental frequency. Set the sweep time=auto couple.
- c. The power spectral density was measured and recorded.

11.3 Test Setup Layout

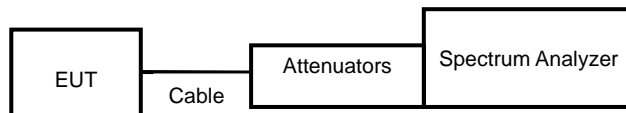



11.4 Test Result and Data

Modulation Standard	Channel	Frequency (MHz)	Maximum Power Density of 3 kHz Bandwidth (dBm)	Limit
GFSK (1Mbps)	00	2402	-9.029	8.00
	19	2440	-5.978	8.00
	39	2480	-8.428	8.00

Note: Test plots refer to the following pages.



Modulation Standard: GFSK (1Mbps)
Channel: 00

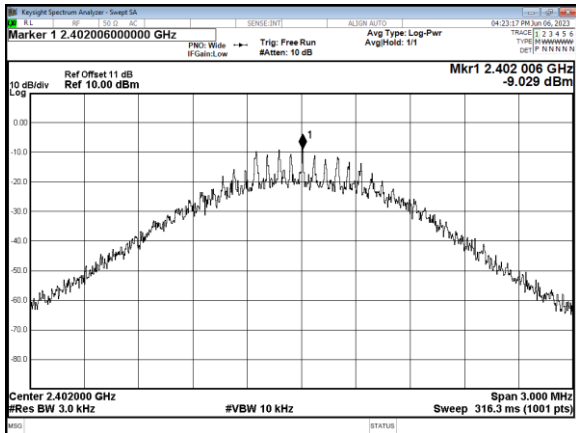

Modulation Standard: GFSK (1Mbps)
Channel: 19

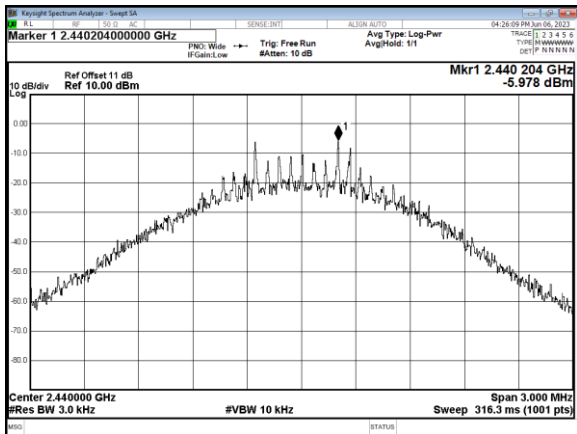

Modulation Standard: GFSK (1Mbps)
Channel: 39

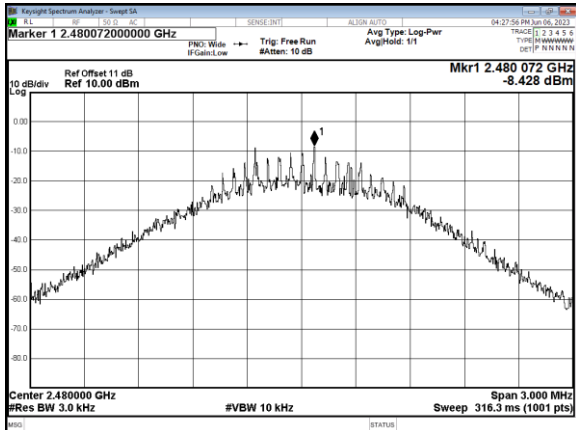

----- End of the report -----