

Product specification

Customer name	LANTAISI	Customer part number			
Part number (P/N)	DZ-RC25-K8.1-L60MM	Specification number	202308015002	edition	01

◆、Overall dimension

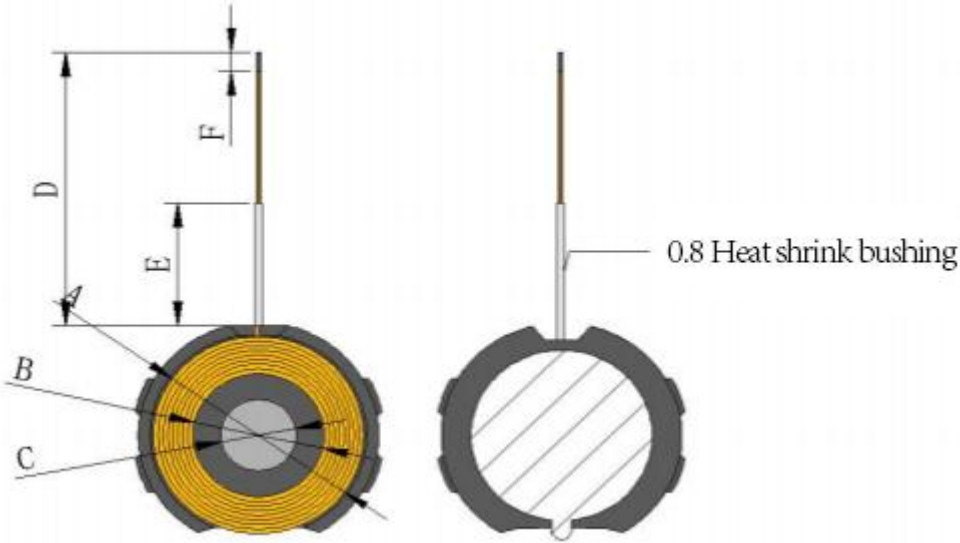

(unit: mm)

A	21.0 ±1.0
B	14.0 ±1.0
C	7.5 ±0.5
D	60.0 ±2.0
E	25.0 ±2.0
F	2.0 ±2.0

备注

- (1)Wire diameter: 0.08*24P twisted wire, single wire double winding
- (2)The coil is wound 14 times
- (3)Glue the bottom
- (4)Whether the start and end lines cross: Yes
- (5)Placed in the middle of the coil N52-7.5*2.2 strong magnetic, 2800-- 3000GS
- (6)As shown in the figure, the root of the lead is covered with 25*0.8MM white heat shrink tubing

◆、Electrical characteristic:

argument	specification	Test condition	Testing instrument
L(W1)	8.1 ±10% μH	100KHz/1V	■TH2816B
DCR(W1)	<200 mΩ	@ 25°C	■CH-502BC
Q	>20 min	100KHz/1V	■TH1816B

◆、Temperature class:

Operating temperature	-40°C~ 125°C
-----------------------	--------------

◆、Bill of materials:

Serial number	description	Material specification	supplier	remark
1	Magnetic sheet	25*2.6 Soft magnetic		
2	Stranded wire	0.08*24P		Stranded wire
3	glue	Double-sided tape		Eco-friendly adhesive paper
4	N52 strong magnetic	7.5*2.2		magnet
5	tin	107H		Thousand island environmental tin
6	glue	Yellow gum		Eco-friendly glue
7	cannula	25*0.5 white heat shrink tubing		Environmentally friendly adhesive