

FCC TEST REPORT
for
Shenzhen Shiningworth Technology Co., Ltd.

SMART TV BOX

Model No.: M6CX, M6SX, M6A, G9CX, G9SX, G10CX, G10SX, G11CX,
G11SX, G12CX, G12SX, G13CX, G13SX, G15CX, G15SX, G16CX, G16SX,
G18CX, G18SX, G19CX, G19SX, G22CX, G22SX, G26CX, G26SX, G28CX,
G28SX, M10S, M10SX, M12S, M12SX, M16S, M16SX

Prepared for : Shenzhen Shiningworth Technology Co., Ltd.
Address : Room 610-613, Block B, Huameiju Business Center, Xihu
Road, Baoan District, Shenzhen, Guangdong, China

Prepared By : Shenzhen Anbotek Compliance Laboratory Limited
Address : 1/F., Building 1, SEC Industrial Park, No.0409 Qianhai Road,
Nanshan District, Shenzhen, Guangdong, China
Tel: (86) 755-26066544
Fax: (86) 755-26014772

Report Number : R011610251I
Date of Test : Oct. 08~ 27, 2016
Date of Report : Oct. 27, 2016

TABLE OF CONTENT

Description

Page

Test Report

1. GENERAL INFORMATION.....	4
1.1. Description of Device (EUT).....	4
1.2. Auxiliary Equipment Used during Test.....	5
1.3. Description of Test Facility.....	5
1.4. Measurement Uncertainty.....	5
2. TEST METHODOLOGY.....	6
2.1. Summary of Test Results.....	6
2.2. Description of Test Modes.....	6
2.3. List of channels:.....	7
3. CONDUCTED EMISSION TEST.....	8
3.1. Block Diagram of Test Setup.....	8
3.2. Power Line Conducted Emission Measurement Limits (15.207).....	8
3.3. Configuration of EUT on Measurement.....	8
3.4. Operating Condition of EUT.....	8
3.5. Test Procedure.....	9
3.6. Test equipment.....	9
3.7. Power Line Conducted Emission Measurement Results.....	9
4. FCC PART 15.247 REQUIREMENTS FOR DSSS & OFDM MODULATION.....	14
4.1 Test Setup.....	14
4.2 6dB Bandwidth.....	14
4.3. Maximum Output Power Test.....	22
4.4. Band Edges Measurement.....	26
4.5. Peak Power Spectral Density.....	62
4.6. Radiated Emissions.....	66
5. ANTENNA APPLICATION.....	77
5.1. Antenna requirement.....	77
5.2. Result.....	77
6. PHOTOGRAPH.....	78
6.1. Photo of Conducted Emission Measurement.....	78
6.2. Photo of Radiation Emission Test.....	78
APPENDIX I (EXTERNAL PHOTOS).....	80
APPENDIX II (INTERNAL PHOTOS).....	84

TEST REPORT

Applicant : Shenzhen Shiningworth Technology Co., Ltd.
Manufacturer : ShenZhen Shiningworth Technology Co., Ltd.
EUT : SMART TV BOX
Model No. : M6CX, M6SX, M6A, G9CX, G9SX, G10CX, G10SX, G11CX, G11SX, G12CX, G12SX, G13CX, G13SX, G15CX, G15SX, G16CX, G16SX, G18CX, G18SX, G19CX, G19SX, G22CX, G22SX, G26CX, G26SX, G28CX, G28SX, M10S, M10SX, M12S, M12SX, M16S, M16SX
Serial No. : N.A.
Trade Mark : N.A.
Rating : DC 5V, 2000mA Via Adapter (Input: AC 100-240V, 50/60Hz, 0.5A, Output: DC 5V, 2000mA)

Measurement Procedure Used:
FCC Part15 Subpart C 2016, Paragraph 15.247

The device described above is tested by Shenzhen Anbotek Compliance Laboratory Limited to determine the maximum emission levels emanating from the device and the severe levels of the device can endure and its performance criterion. The measurement results are contained in this test report and Shenzhen Anbotek Compliance Laboratory Limited is assumed full of responsibility for the accuracy and completeness of these measurements. Also, this report shows that the EUT (Equipment Under Test) is technically compliant with the FCC Part 15 Subpart C requirements.

This report applies to above tested sample only and shall not be reproduced in part without written approval of Shenzhen Anbotek Compliance Laboratory Limited.

Date of Test : Oct. 08~ 27, 2016

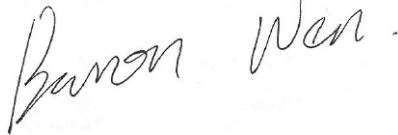
Prepared by : 
(Tested Engineer / Baron Wen)

Reviewer : 
(Project Manager / Amy Ding)

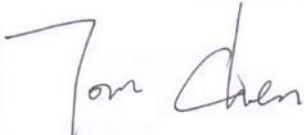
Approved & Authorized Signer : 
(Manager / Tom Chen)

1. GENERAL INFORMATION

1.1. Description of Device (EUT)

EUT	: SMART TV BOX
Model Number	: M6CX, M6SX, M6A, G9CX, G9SX, G10CX, G10SX, G11CX, G11SX, G12CX, G12SX, G13CX, G13SX, G15CX, G15SX, G16CX, G16SX, G18CX, G18SX, G19CX, G19SX, G22CX, G22SX, G26CX, G26SX, G28CX, G28SX, M10S, M10SX, M12S, M12SX, M16S, M16SX (Note: All samples are the same except the model number and colour, so we prepare “M6CX” for test only.)
Test Power Supply	: AC 120V, 60Hz for adapter/ AC 240V, 60Hz for adapter
Adapter	: Model No.: GKYP50200050US1 Input: AC 100-240V, 50/60Hz, 0.5A Output: DC 5V, 2000mA
RF Transmission Frequency	: 2412MHz~2462MHz (802.11b/802.11g/802.11n(HT20)) 2422MHz~2452MHz (802.11n(HT40))
Channels	: 11 For (802.11b/802.11g/802.11n(HT20)) 7 For (802.11n(HT40))
Modulation	: 802.11b CCK; 802.11g OFDM; 802.11n MCS
Antenna Gain:	: 1dBi
Applicant Address	: Shenzhen Shiningworth Technology Co., Ltd. Room 610-613, Block B, Huameiju Business Center, Xinhua Road, Baoan District, Shenzhen, Guangdong, China
Manufacturer Address	: ShenZhen Shiningworth Technology Co., Ltd. 3F, Building 1, Fusen Park, Hangcheng Rd., Gushu, Bao'an District, Shenzhen, China
Factory Address	: ShenZhen Shiningworth Technology Co., Ltd. 3F, Building 1, Fusen Park, Hangcheng Rd., Gushu, Bao'an District, Shenzhen, China
Date of receipt	: Oct. 08, 2016
Date of Test	: Oct. 08~ 27, 2016

1.2. Auxiliary Equipment Used during Test

TV : Manufacturer: SONY
M/N: KDL-26EX550
S/N: 1012240
CE , FCC: DOC

1.3. Description of Test Facility

The test facility is recognized, certified, or accredited by the following organizations:

FCC-Registration No.: 752021

Shenzhen Anbotek Compliance Laboratory Limited, EMC Laboratory has been registered and fully described in a report filed with the (FCC) Federal Communications Commission. The acceptance letter from the FCC is maintained in our files. Registration 752021, July 06, 2016.

IC-Registration No.: 8058A-1

Shenzhen Anbotek Compliance Laboratory Limited., EMC Laboratory has been registered and fully described in a report filed with the (IC) Industry Canada. The acceptance letter from the IC is maintained in our files. Registration 8058A, Jun. 13, 2016.

Test Location

All Emissions tests were performed at
Shenzhen Anbotek Compliance Laboratory Limited. at 1/F., Building 1, SEC
Industrial Park, No.0409 Qianhai Road, Nanshan District, Shenzhen, Guangdong,
China

1.4. Measurement Uncertainty

Radiation Uncertainty : Ur = 4.1 dB (Horizontal)
Ur = 4.3 dB (Vertical)
Conduction Uncertainty : Uc = 3.4dB

2. TEST METHODOLOGY

The tests documented in this report were performed in accordance with ANSI C63.10: 2013 and FCC Part 15, Paragraph 15.247.

2.1. Summary of Test Results

The EUT has been tested according to the following specifications:

Standard	Test Type	Result	Notes
FCC Part 15, Paragraph 15.107, 15.207	Conducted Emission Test	PASS	Complies
FCC Part 15, Paragraph 15.247(b)(1)	Maximum Output Power	PASS	Complies
FCC Part 15, Paragraph 15.247(a)(2)	6dB Bandwidth	PASS	Complies
FCC Part 15, Paragraph 15.247(c)	100kHz Bandwidth of Frequency Band Edges	PASS	Complies
FCC Part 15, Paragraph 15.209(a)(f)	Spurious Emission	PASS	Complies
FCC Part 15, Paragraph 15.247(a)(1)	Frequency Separation	-	N/A
FCC Part 15, Paragraph 15.247(a)(1)(iii)	Number of Hopping Frequency	-	N/A
FCC Part 15, Paragraph 15.247(a)(1)(iii)	Time of Occupancy	-	N/A
FCC Part 15, Paragraph 15.247(c)	Peak Power Density	PASS	Complies

2.2. Description of Test Modes

The EUT has been tested under operating condition.

Software used to control the EUT for staying in continuous transmitting and receiving mode is programmed.

IEEE802.11b: Channel 1(2412MHz), Channel 6(2437MHz) and Channel 11(2462MHz) with 1 Mbps lowest data rate (worst case) are chosen for the final testing.

IEEE802.11g: Channel 1(2412MHz), Channel 6(2437MHz) and Channel 11(2462MHz) with 6 Mbps lowest data rate (the worst case) are chosen for the final testing.

IEEE802.11n (HT20): Channel 1(2412MHz), Channel 6(2437MHz) and Channel 11(2462MHz) with MCS 0 Mbps lowest data rate (the worst case) are chosen for the final testing.

IEEE802.11n (HT40): Channel 3(2422MHz), Channel 6(2437MHz) and Channel 9(2452MHz) with MCS 0 Mbps lowest data rate (the worst case) are chosen for the final testing.

2.3. List of channels:

√ - available

X - tested

Number	Frequency(MHz)		802.11 b/g/n (HT20)	802.11 b/g/n (HT40)
1	2412	√	X	
2	2417	√		
3	2422	√		X
4	2427	√		
5	2432	√		
6	2437	√	X	X
7	2442	√		
8	2447	√		
9	2452	√		X
10	2457	√		
11	2462	√	X	

3. Conducted Emission Test

3.1. Block Diagram of Test Setup

3.1.1. Block diagram of connection between the EUT and simulators

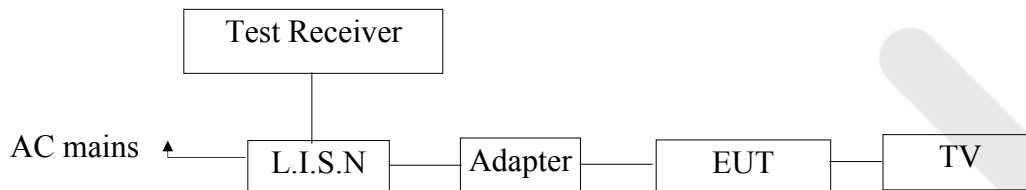

3.2. Power Line Conducted Emission Measurement Limits (15.207)

Frequency MHz	Limits dB(μV)	
	Quasi-peak Level	Average Level
0.15 ~ 0.50	66 ~ 56*	56 ~ 46*
0.50 ~ 5.00	56	46
5.00 ~ 30.00	60	50

- Notes: 1. *Decreasing linearly with logarithm of frequency.
2. The lower limit shall apply at the transition frequencies.

3.3. Configuration of EUT on Measurement

The following equipments are installed on Power Line Conducted Emission Measurement to meet the commission requirement and operating regulations in a manner which tends to maximize its emission characteristics in a normal application.

3.4. Operating Condition of EUT

- 3.4.1. Setup the EUT and simulator as shown as Section 3.1.
- 3.4.2. Turn on the power of all equipment.
- 3.4.3. Let the EUT work in test mode (HDMI+WAN Mode, HDMI+WiFi Mode) and measure it.

3.5. Test Procedure

The EUT system is connected to the power mains through a line impedance stabilization network (L.I.S.N.). This provides a 50ohm coupling impedance for the EUT system. Please refer the block diagram of the test setup and photographs. Both sides of AC line are checked to find out the maximum conducted emission. In order to find the maximum emission levels, the relative positions of equipment and all of the interface cables shall be changed according to FCC ANSI C63.10-2013 on Conducted Emission Measurement.

The bandwidth of test receiver (ESCI) set at 9KHz.

The frequency range from 150KHz to 30MHz is checked.

The test results are reported on Section 3.6.

3.6. Test equipment

Item	Equipment	Manufacturer	Model No.	Serial No.	Last Cal.	Cal. Interval
1.	Two-Line V-network	Rohde & Schwarz	ENV216	100055	Apr. 16, 2016	1 Year
2.	EMI Test Receiver	Rohde & Schwarz	ESCI	100627	Apr. 16, 2016	1 Year
3.	RF Switching Unit	Compliance Direction	RSU-M2	38303	Apr. 16, 2016	1 Year

3.7. Power Line Conducted Emission Measurement Results

PASS.

The frequency range from 150KHz to 30 MHz is investigated.

The EUT was tested on (HDMI+WAN Mode, HDMI+WiFi Mode) modes, only the worst data of (HDMI+WiFi Mode) is attached in the following pages.

CONDUCTED EMISSION TEST DATA

Test Site: 1# Shielded Room
 Operating Condition: HDMI+WiFi Mode
 Test Specification: AC 120V, 60Hz for adapter
 Comment: Live Line
 Tem.:25°C Hum.:50%

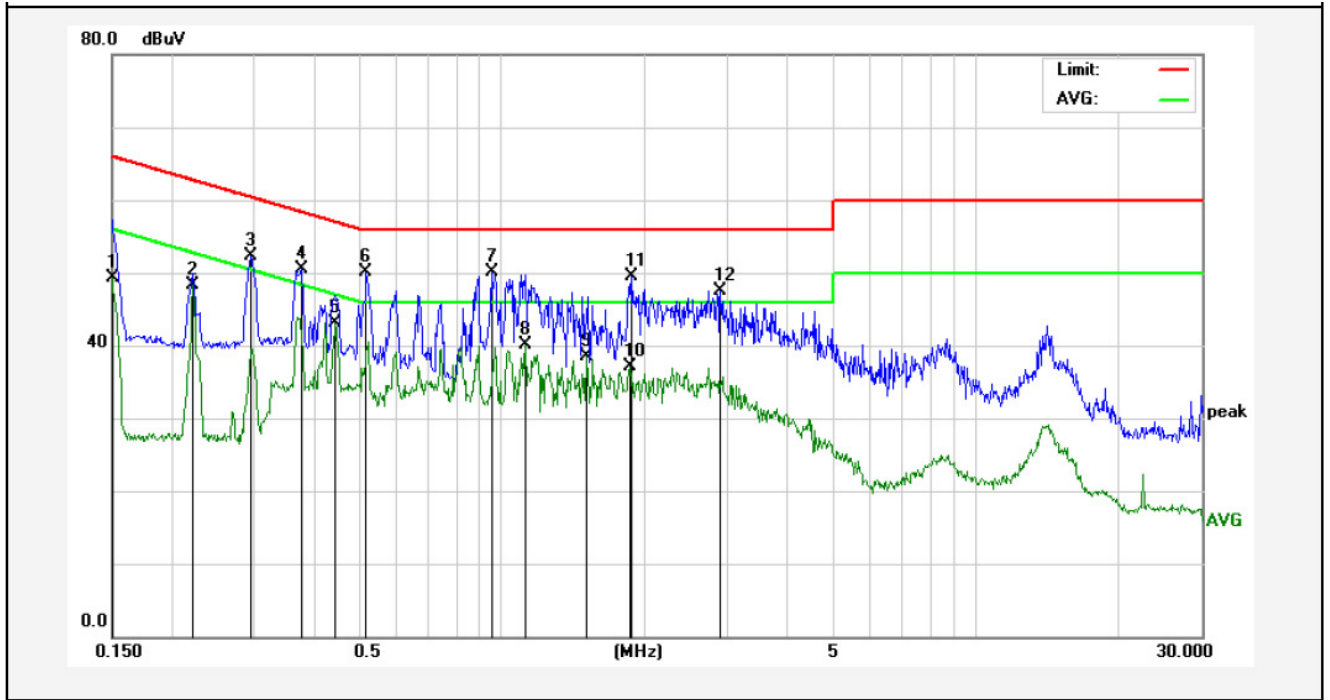

No.	Freq. (MHz)	Reading (dBuV)	Factor (dB)	Result (dBuV)	Limit (dBuV)	Over Limit (dB)	Detector	Remark
1	0.1499	29.27	19.90	49.17	56.00	-6.83	AVG	
2	0.2220	28.37	19.90	48.27	52.74	-4.47	AVG	
3	0.2939	32.25	19.90	52.15	60.41	-8.26	QP	
4	0.3780	30.56	19.89	50.45	58.32	-7.87	QP	
5	0.4460	23.11	19.89	43.00	46.95	-3.95	AVG	
6	0.5180	30.08	19.98	50.06	56.00	-5.94	QP	
7	0.9499	30.05	19.98	50.03	56.00	-5.97	QP	
8	1.1180	20.05	20.06	40.11	46.00	-5.89	AVG	
9	1.5060	18.47	20.06	38.53	46.00	-7.47	AVG	
10	1.8660	17.11	20.12	37.23	46.00	-8.77	AVG	
11	1.8779	29.46	20.12	49.58	56.00	-6.42	QP	
12	2.8940	27.45	20.12	47.57	56.00	-8.43	QP	

CONDUCTED EMISSION TEST DATA

Test Site: 1# Shielded Room
 Operating Condition: HDMI+WiFi Mode
 Test Specification: AC 120V, 60Hz for adapter
 Comment: Neutral Line
 Tem.:25°C Hum.:50%

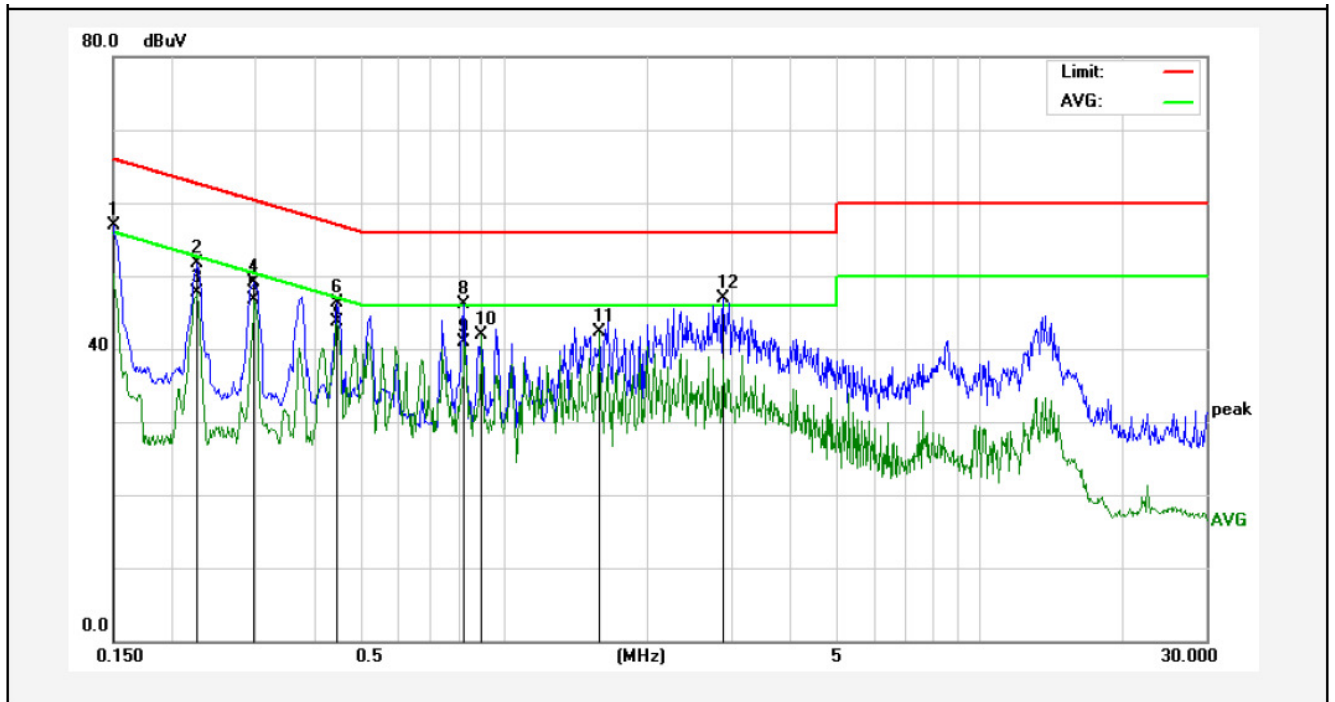

No.	Freq. (MHz)	Reading (dBuV)	Factor (dB)	Result (dBuV)	Limit (dBuV)	Over Limit (dB)	Detector	Remark
1	0.1499	36.84	19.90	56.74	66.00	-9.26	QP	
2	0.2260	31.79	19.90	51.69	62.59	-10.90	QP	
3	0.2260	27.67	19.90	47.57	52.59	-5.02	AVG	
4	0.2977	29.19	19.89	49.08	60.30	-11.22	QP	
5	0.2977	26.70	19.89	46.59	50.30	-3.71	AVG	
6	0.4460	26.36	19.98	46.34	56.95	-10.61	QP	
7	0.4460	23.80	19.98	43.78	46.95	-3.17	AVG	
8	0.8257	26.09	20.16	46.25	56.00	-9.75	QP	
9	0.8257	20.97	20.16	41.13	46.00	-4.87	AVG	
10	0.8980	21.95	20.08	42.03	46.00	-3.97	AVG	
11	1.5820	22.32	20.14	42.46	46.00	-3.54	AVG	
12	2.8900	26.88	20.16	47.04	56.00	-8.96	QP	

CONDUCTED EMISSION TEST DATA

Test Site: 1# Shielded Room
 Operating Condition: HDMI+WiFi Mode
 Test Specification: AC 240V, 60Hz for adapter
 Comment: Live Line
 Tem.:25°C Hum.:50%

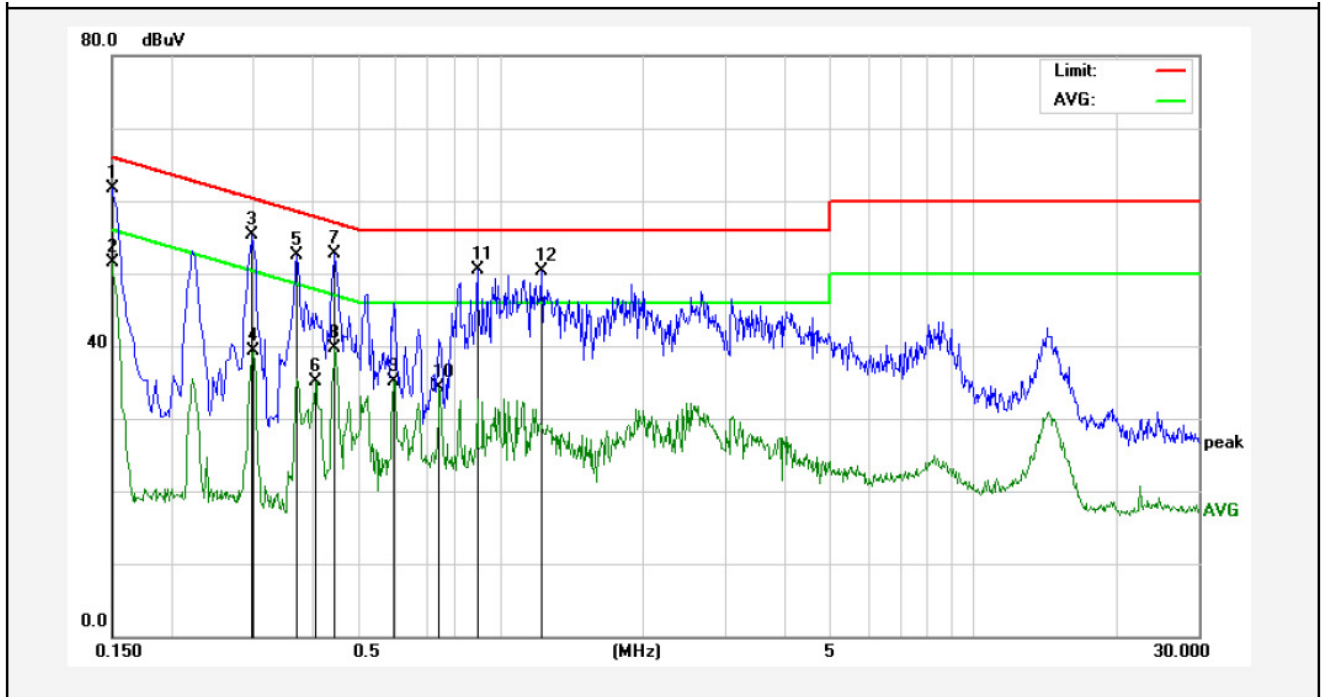

No.	Freq. (MHz)	Reading (dBuV)	Factor (dB)	Result (dBuV)	Limit (dBuV)	Over Limit (dB)	Detector	Remark
1	0.1499	41.64	19.90	61.54	66.00	-4.46	QP	
2	0.1499	31.53	19.90	51.43	56.00	-4.57	AVG	
3	0.2980	35.25	19.89	55.14	60.30	-5.16	QP	
4	0.2987	19.28	19.89	39.17	50.28	-11.11	AVG	
5	0.3700	32.56	19.91	52.47	58.50	-6.03	QP	
6	0.4060	15.10	19.94	35.04	47.73	-12.69	AVG	
7	0.4460	32.71	19.95	52.66	56.95	-4.29	QP	
8	0.4460	19.79	19.95	39.74	46.95	-7.21	AVG	
9	0.5940	15.18	19.99	35.17	46.00	-10.83	AVG	
10	0.7420	14.32	20.04	34.36	46.00	-11.64	AVG	
11	0.8900	30.44	20.05	50.49	56.00	-5.51	QP	
12	1.2220	30.28	20.13	50.41	56.00	-5.59	QP	

CONDUCTED EMISSION TEST DATA

Test Site: 1# Shielded Room
 Operating Condition: HDMI+WiFi Mode
 Test Specification: AC 240V, 60Hz for adapter
 Comment: Neutral Line
 Tem.:25°C Hum.:50%

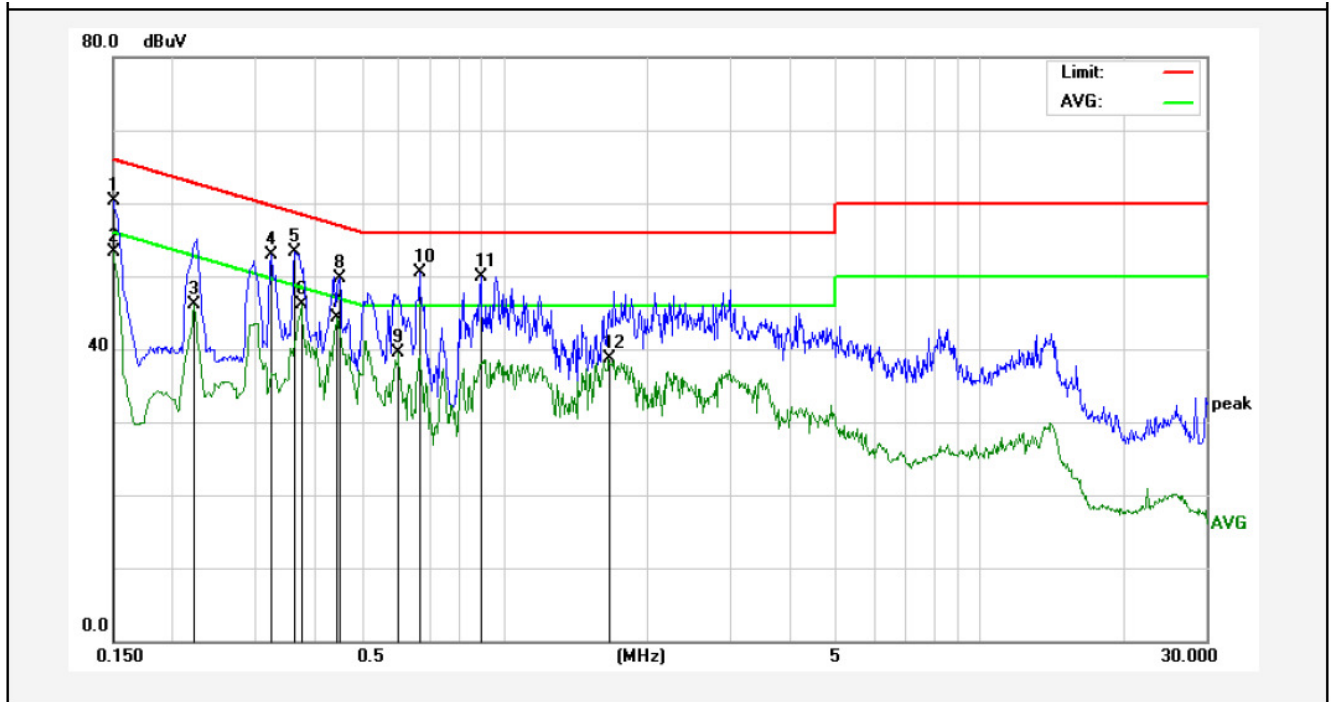

No.	Freq. (MHz)	Reading (dBuV)	Factor (dB)	Result (dBuV)	Limit (dBuV)	Over Limit (dB)	Detector	Remark
1	0.1499	40.27	19.90	60.17	66.00	-5.83	QP	
2	0.1499	33.33	19.90	53.23	56.00	-2.77	AVG	
3	0.2220	26.01	19.90	45.91	52.74	-6.83	AVG	
4	0.3220	32.97	19.90	52.87	59.65	-6.78	QP	
5	0.3620	33.21	19.89	53.10	58.68	-5.58	QP	
6	0.3740	26.09	19.89	45.98	48.41	-2.43	AVG	
7	0.4460	24.34	19.93	44.27	46.95	-2.68	AVG	
8	0.4500	29.76	19.94	49.70	56.87	-7.17	QP	
9	0.5980	19.49	19.98	39.47	46.00	-6.53	AVG	
10	0.6620	30.49	19.99	50.48	56.00	-5.52	QP	
11	0.8940	29.94	20.05	49.99	56.00	-6.01	QP	
12	1.6580	18.61	20.13	38.74	46.00	-7.26	AVG	

4. FCC Part 15.247 Requirements for DSSS & OFDM Modulation

4.1 Test Setup

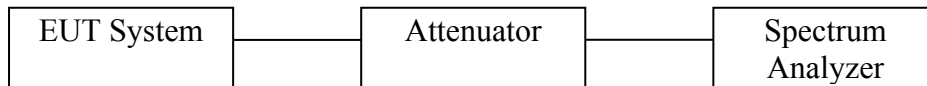

4.2 6dB Bandwidth

a. Limit

For the direct sequence systems, the minimum 6dB bandwidth shall be at least 500kHz.

b. Test Procedure

1. Place the EUT on the table and set it in the transmitting mode.
2. Remove the antenna from the EUT and then connect a low loss RF cable from the antenna port to the spectrum analyzer.
3. Set the spectrum analyzer as:
RBW = 100kHz, VBW $\geq 3 \times$ RBW = 300kHz,
Detector= Peak
Trace mode= Max hold.
Sweep- auto couple.
4. Mark the peak frequency and -6 dB (upper and lower) frequency.
5. Repeat until all the rest channels are investigated.

20dB Bandwidth:

C63.10

Occupied Bandwidth (OBW=20dB Bandwidth)

1. Set RBW=1%~5% OBW
2. Set the VBW $\geq 3 \times$ RBW
3. Set the span range between 2 times and 5 times of the OBW
4. Sweep Time= Auto
Detector= Peak
Trace= Max hold
5. Once the reference level is established, the equipment is conditioned with typical modulating signals to produce the worst case (i.e. the widest) bandwidth. Unless otherwise specified for an unlicensed wireless device, measure the bandwidth at the -20 dB levels with respect to the reference level.

c. Test Setup See 4.1

d. Test Equipment

Item	Equipment	Manufacturer	Model No.	Serial No.	Last Cal.	Cal. Interval
1.	Spectrum Analysis	Agilent	E4407B	US39390582	Apr. 16, 2016	1 Year
2.	Preamplifier	Instruments corporation	EMC011830	980100	Apr. 16, 2016	1 Year
3.	EMI Test Receiver	Rohde & Schwarz	ESPI	101604	Apr. 16, 2016	1 Year
4.	Double Ridged Horn Antenna	Instruments corporation	GTH-0118	351600	Apr. 19, 2016	1 Year
5.	Bilog Broadband Antenna	Schwarzbeck	VULB9163	VULB 9163-289	Apr. 19, 2016	1 Year
6.	Pre-amplifier	SONOMA	310N	186860	Apr. 16, 2016	1 Year
7.	EMI Test Software EZ-EMC	SHURPLE	N/A	N/A	N/A	N/A
8	Power Sensor	DAER	RPR3006W	15I00041SN046	Jun 30, 2016	1 Year
9	MXA Spectrum Analysis	Agilent	N9020A	MY51170037	Jun 30, 2016	1 Year
10	MXG RF Vector Signal Generator	Agilent	N5182A	MY48180656	Jun 30, 2016	1 Year
11	Signal Generator	Agilent	E4421B	MY41000743	Jun 30, 2016	1 Year
12	DC Power supply	IV	IV-8080	YQSB0096	Jun 30, 2016	1 Year
13	TEMP&HUMI PROGRAMMABLE CHAMBER	Bell Group	BE-THK-150M8	SE-0137	Mar. 16, 2016	1 Year

e. Test Results

Pass.

f. Test Data

6dB Bandwidth

Test mode: IEEE 802.11b

Channel	Frequency (MHz)	Bandwidth (MHz)	Limit (kHz)	Results
Low	2412	10.04		Pass
Mid	2437	10.02	>500	Pass
High	2462	10.02		Pass

Test mode: IEEE 802.11g

Channel	Frequency (MHz)	Bandwidth (MHz)	Limit (kHz)	Results
Low	2412	16.56		Pass
Mid	2437	16.57	>500	Pass
High	2462	16.56		Pass

Test mode: IEEE 802.11n (HT20)

Channel	Frequency (MHz)	Bandwidth (MHz)	Limit (kHz)	Results
Low	2412	16.56		Pass
Mid	2437	16.57	>500	Pass
High	2462	16.56		Pass

Test mode: IEEE 802.11n (HT40)

Channel	Frequency (MHz)	Bandwidth (MHz)	Limit (kHz)	Results
Low	2422	35.35		Pass
Mid	2437	35.17	>500	Pass
High	2452	35.18		Pass

Test Plots See the following page.

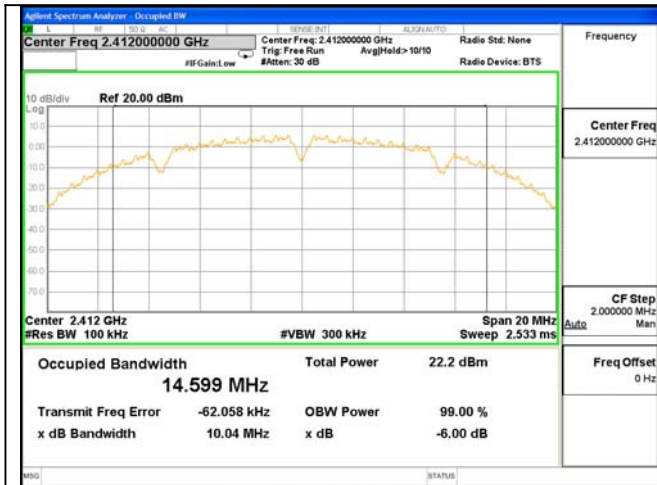

Test Mode: 802.11b---Low

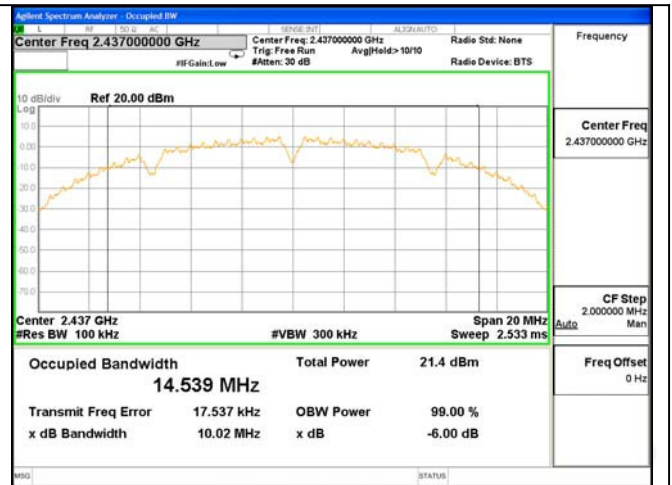

Test Mode: 802.11b---Mid

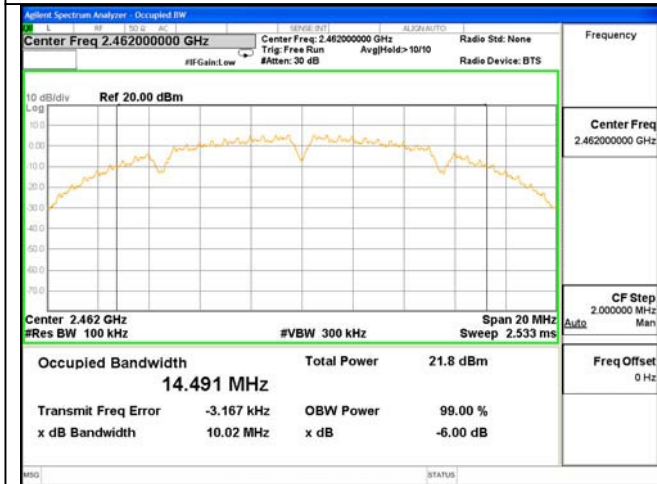

Test Mode: 802.11b---High

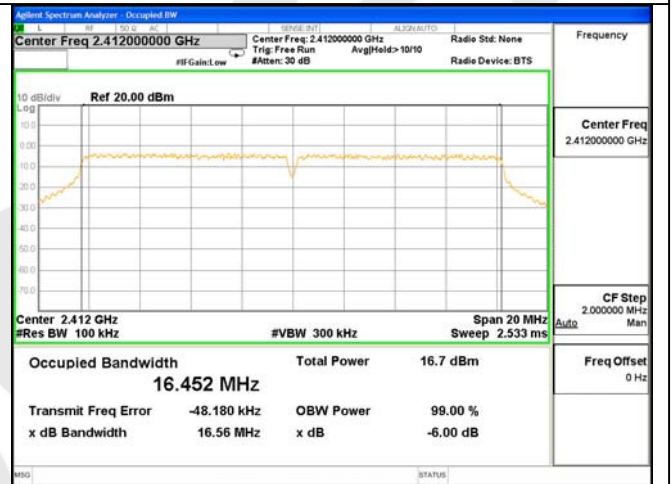

Test Mode: 802.11g---Low

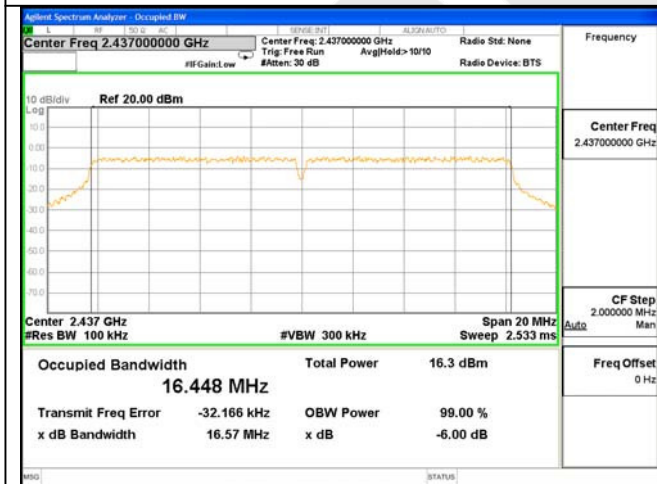

Test Mode: 802.11g---Mid

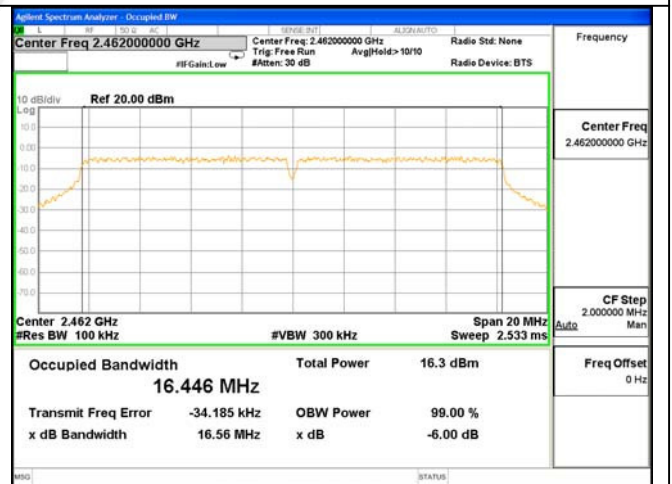

Test Mode: 802.11g---High

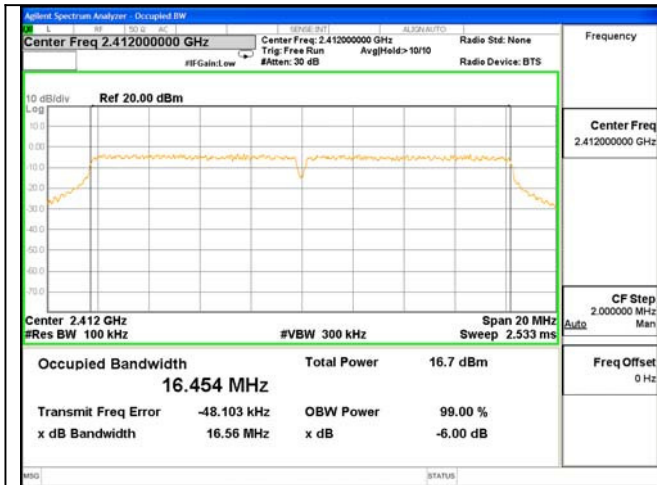

Test Mode: 802.11n20---Low

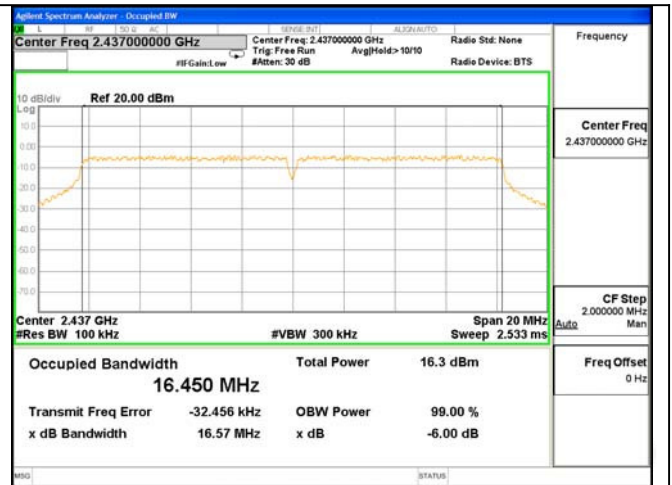

Test Mode: 802.11n20---Mid

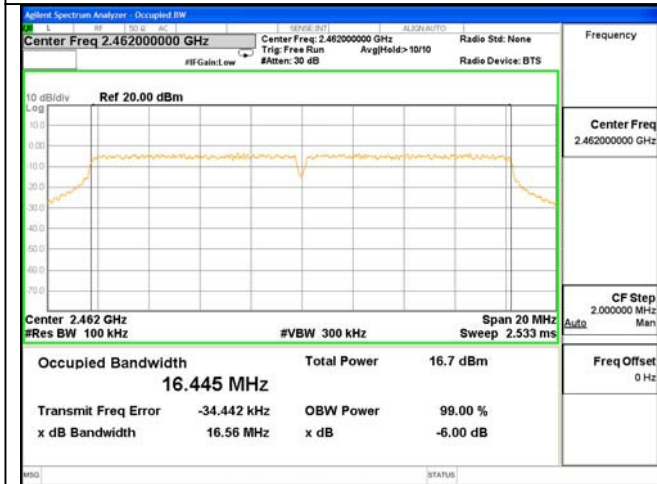

Test Mode: 802.11n20---High

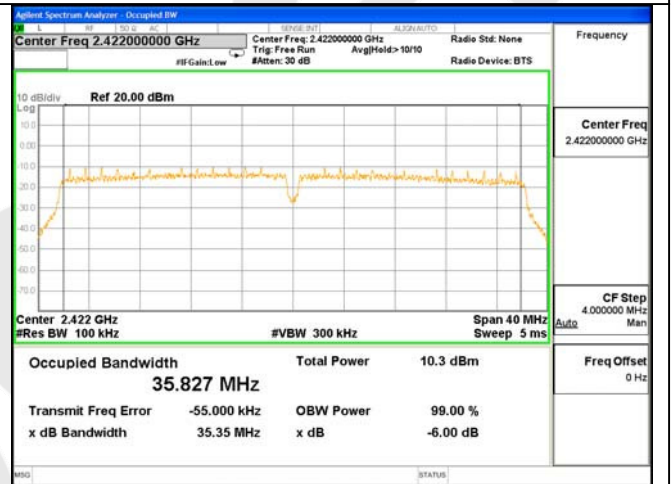

Test Mode: 802.11n40---Low

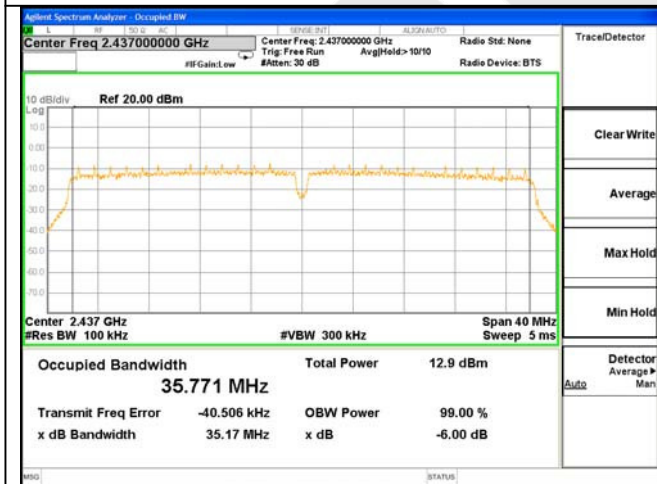

Test Mode: 802.11n40---Mid

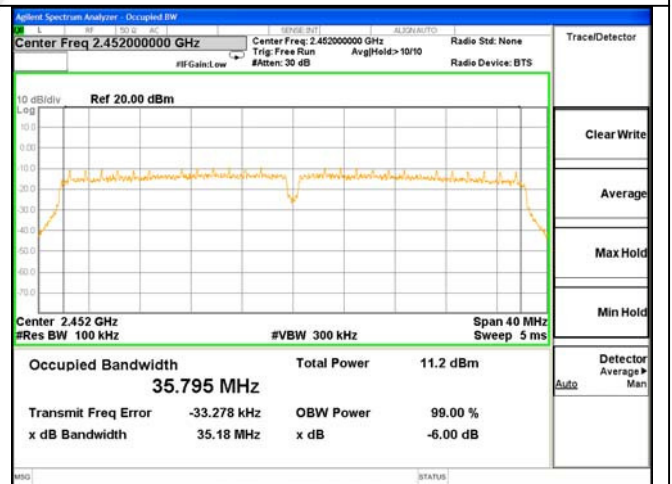

Test Mode: 802.11n40---High

20dB Bandwidth

Test mode: IEEE 802.11b

Channel	Frequency (MHz)	Bandwidth (MHz)	Results
Low	2412	17.04	Pass
Mid	2437	16.71	Pass
High	2462	16.34	Pass

Test mode: IEEE 802.11g

Channel	Frequency (MHz)	Bandwidth (MHz)	Results
Low	2412	19.22	Pass
Mid	2437	19.20	Pass
High	2462	19.25	Pass

Test mode: IEEE 802.11n (HT20)

Channel	Frequency (MHz)	Bandwidth (MHz)	Results
Low	2412	19.18	Pass
Mid	2437	19.31	Pass
High	2462	19.22	Pass

Test mode: IEEE 802.11n (HT40)

Channel	Frequency (MHz)	Bandwidth (MHz)	Results
Low	2422	43.22	Pass
Mid	2437	43.20	Pass
High	2452	42.88	Pass

Test Plots See the following page.

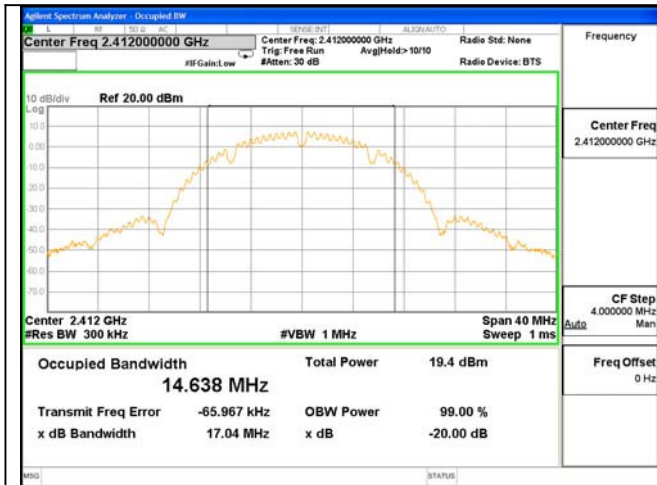

Test Mode: 802.11b---Low

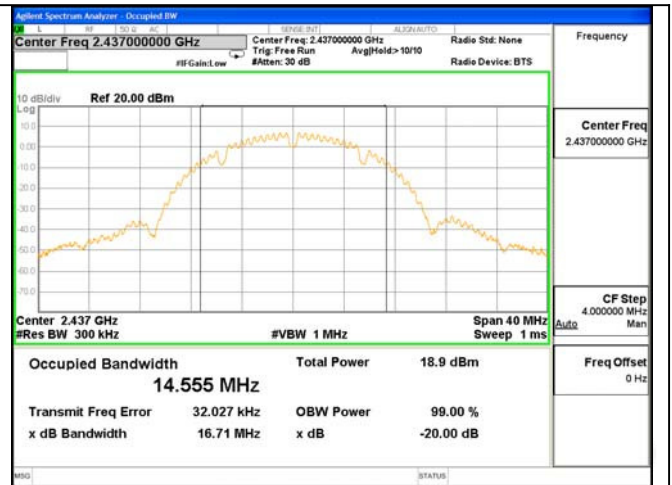

Test Mode: 802.11b---Mid

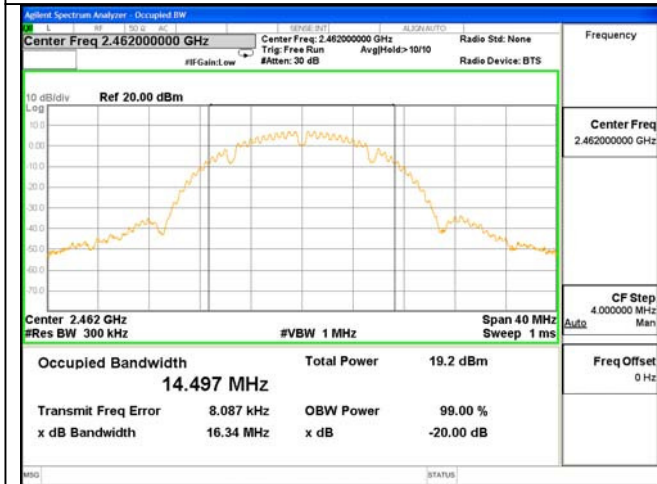

Test Mode: 802.11b---High

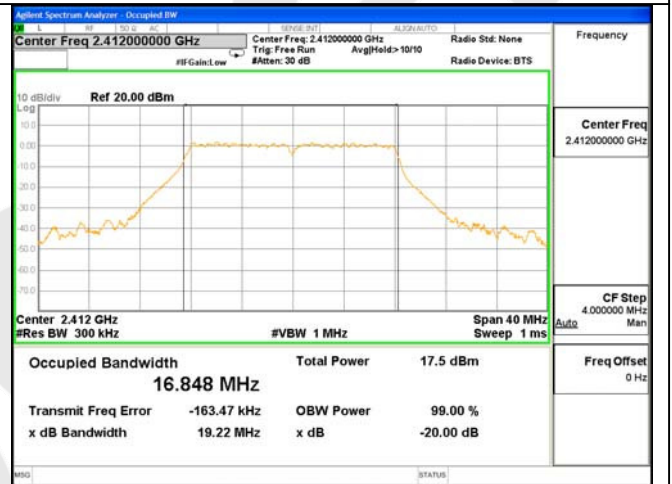

Test Mode: 802.11g---Low

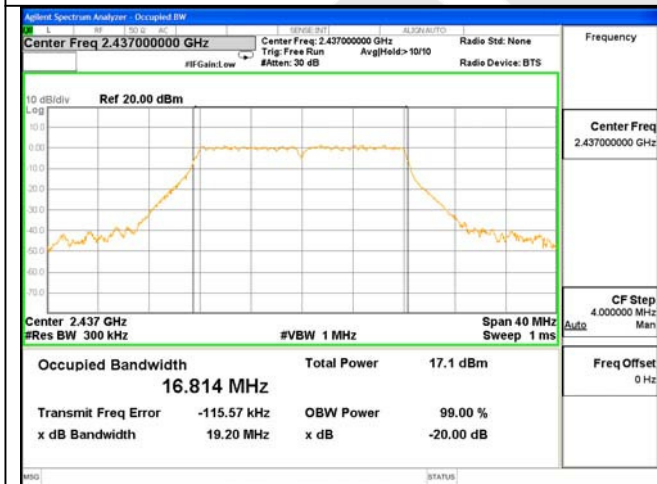

Test Mode: 802.11g---Mid

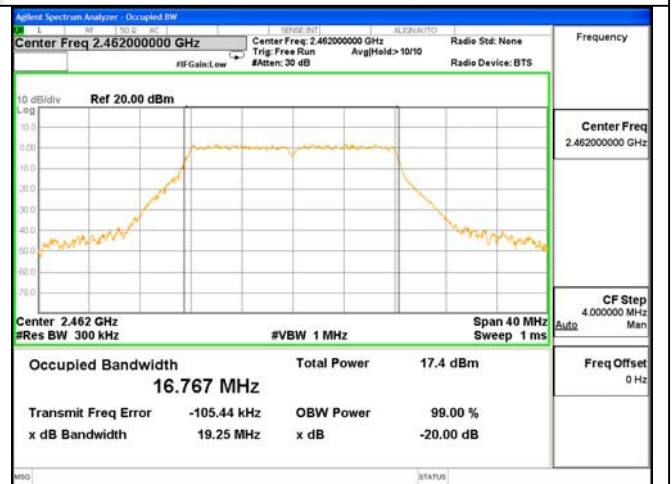

Test Mode: 802.11g---High

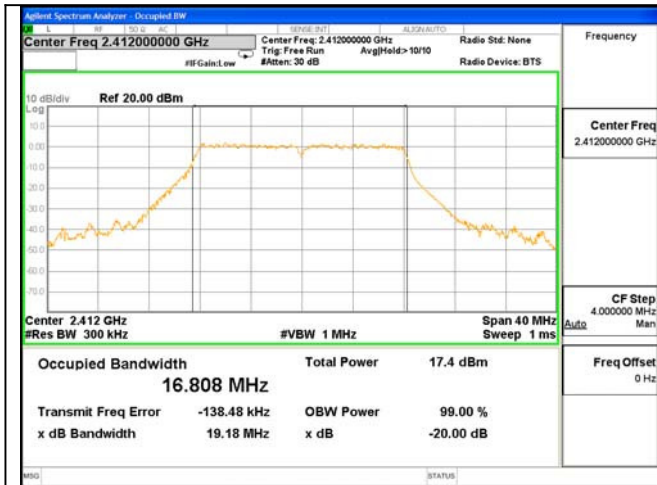

Test Mode: 802.11n20---Low

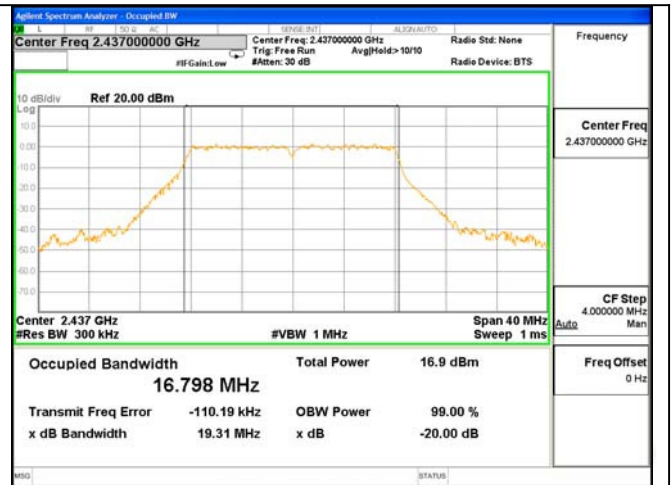

Test Mode: 802.11n20---Mid

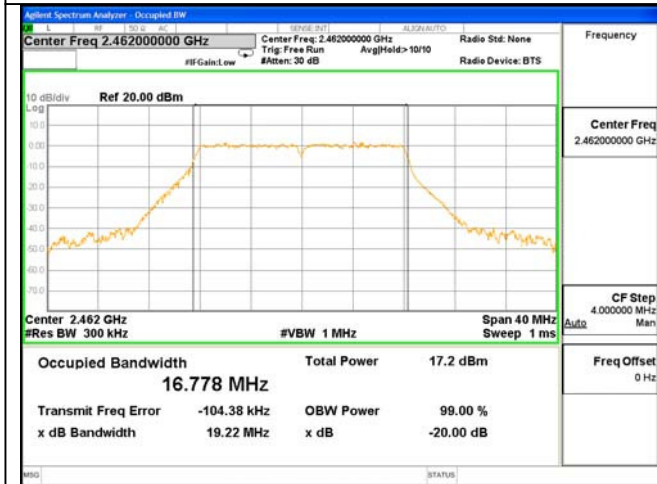

Test Mode: 802.11n20---High

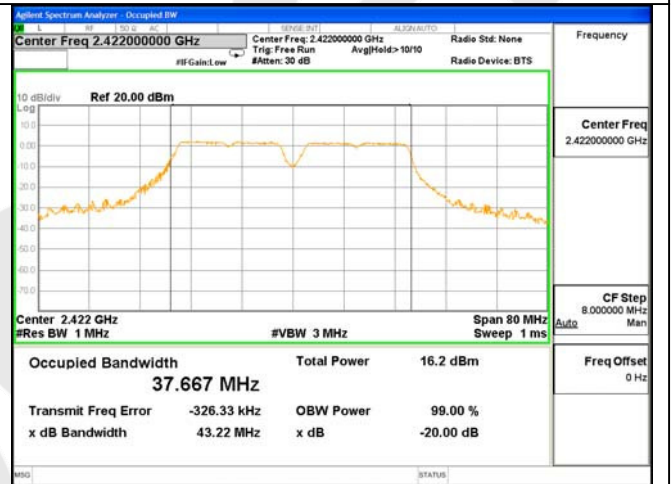

Test Mode: 802.11n40---Low

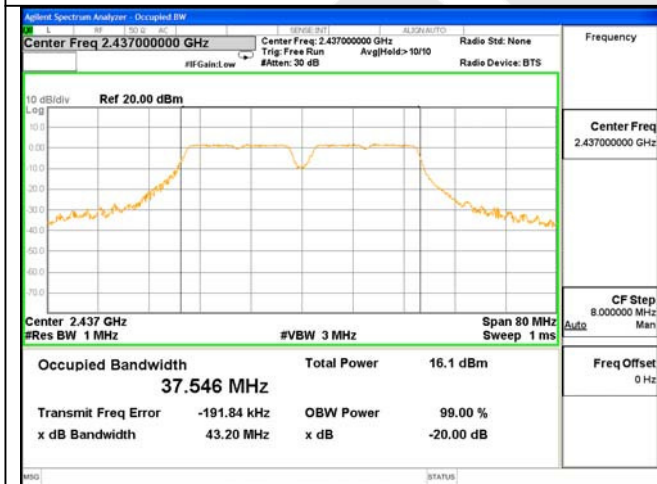

Test Mode: 802.11n40---Mid

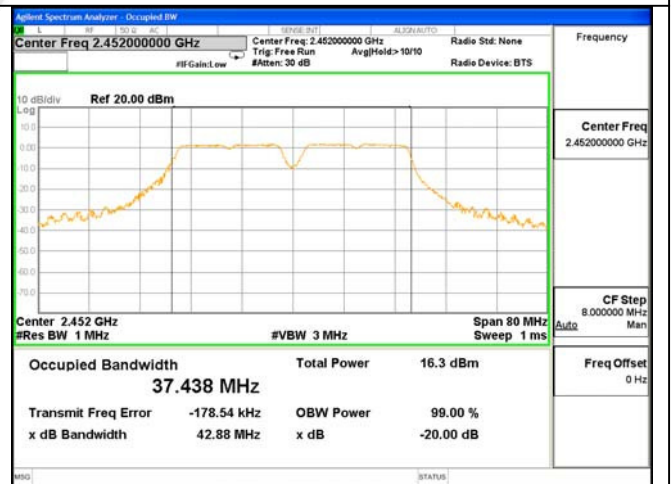

Test Mode: 802.11n40---High

4.3. Maximum Output Power Test

a. Limit

The maximum output power of the intentional radiator shall not exceed the following:

1. For systems using digital modulation in the bands of 902-928 MHz, 2400-2483.5 MHz, and 5725-5850 MHz: 1 watt (30dBm).
2. Except as shown in paragraphs (b)(3) (i), (ii) and (iii) of this section, if transmitting antenna of directional gain greater than 6 dBi are used the peak output power from the intentional radiator shall be reduced below the stated values in paragraphs (b)(1) or (b)(2) of this section, as appropriate, by the amount in dB that the directional gain of the antenna exceeds 6 dBi.

b. Configuration of Measurement

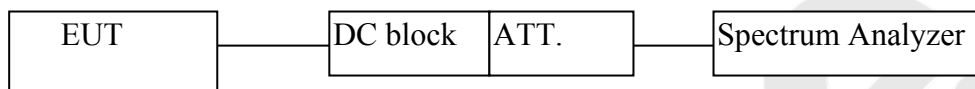

c. Data Rates

IEEE802.11b: Channel 1(2412MHz), Channel 6(2437MHz) and Channel 11(2462MHz) with 1 Mbps data rate (worst case) are chosen for the final testing.

IEEE802.11g: Channel 1(2412MHz), Channel 6(2437MHz) and Channel 11(2462MHz) with 6 Mbps data rate (the worst case) are chosen for the final testing.

IEEE802.11n (HT20): Channel 1(2412MHz), Channel 6(2437MHz) and Channel 11(2462MHz) with 6.5Mbps data rate (the worst case) are chosen for the final testing.

IEEE802.11n (HT40): Channel 3(2422MHz), Channel 6(2437MHz) and Channel 9(2452MHz) with 13.5Mbps data rate (the worst case) are chosen for the final testing.

d. Test Procedure

This test was according the kDB 558074 D01 DTS Meas Guidance v03r05 9.1.1:

1. Set span to at least 1.5 times the OBW.
2. Set the RBW = 1~5% of the OBW, not to exceed 1MHz.
3. Set VBW ≥ 3 * RBW.
4. Detector = Average.
5. Sweep time = auto couple.
6. Trace mode = max hold.
7. Allow trace to fully stabilize.

e. Test Equipment

Same as the equipment listed in 4.2.

f. Test Results

Pass.

g. Test Data

Test mode: IEEE 802.11b

Channel	Frequency (MHz)	Maximum transmit power (dBm)	Limit		Result
			(dBm)	(watts)	
Low	2412	19.82	30	1	Pass
Mid	2437	19.04			Pass
High	2462	19.32			Pass

Test mode: IEEE 802.11g

Channel	Frequency (MHz)	Maximum transmit power (dBm)	Limit		Result
			(dBm)	(watts)	
Low	2412	18.21	30	1	Pass
Mid	2437	17.55			Pass
High	2462	18.17			Pass

Test mode: IEEE 802.11n (HT20)

Channel	Frequency (MHz)	Maximum transmit power (dBm)	Limit		Result
			(dBm)	(watts)	
Low	2412	18.02	30	1	Pass
Mid	2437	17.58			Pass
High	2462	18.30			Pass

Test mode: IEEE 802.11n (HT40)

Channel	Frequency (MHz)	Maximum transmit power (dBm)	Limit		Result
			(dBm)	(watts)	
Low	2422	17.00	30	1	Pass
Mid	2437	16.75			Pass
High	2452	16.91			Pass



Test Mode: 802.11b---Low



Test Mode: 802.11b---Mid



Test Mode: 802.11b---High

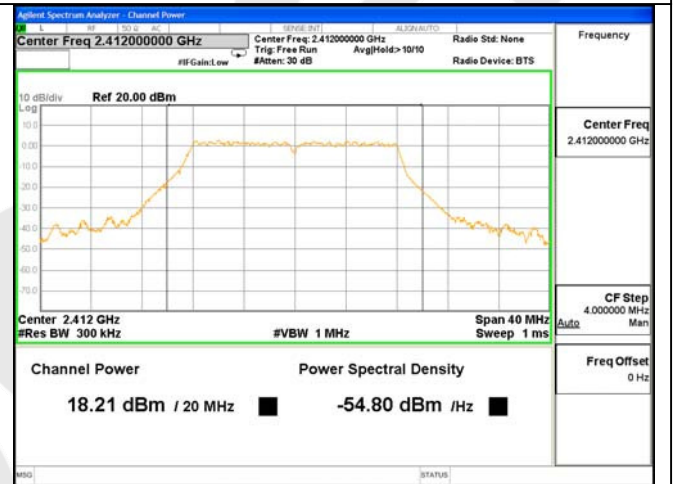

Test Mode: 802.11g---Low



Test Mode: 802.11g---Mid



Test Mode: 802.11g---High



Test Mode: 802.11n20---Low



Test Mode: 802.11n20---Mid



Test Mode: 802.11n20---High

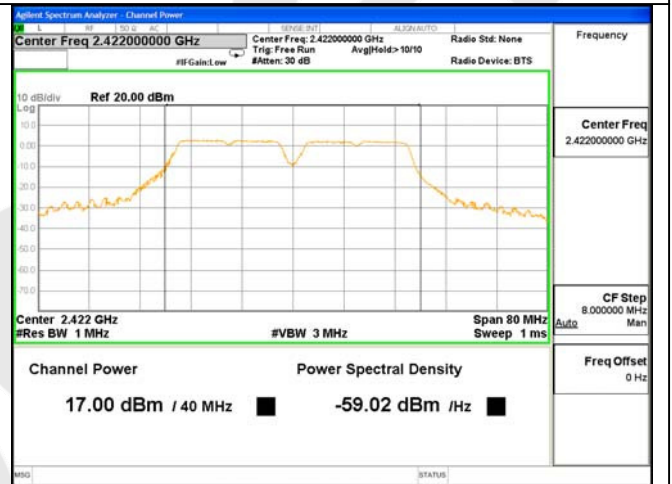

Test Mode: 802.11n40---Low



Test Mode: 802.11n40---Mid

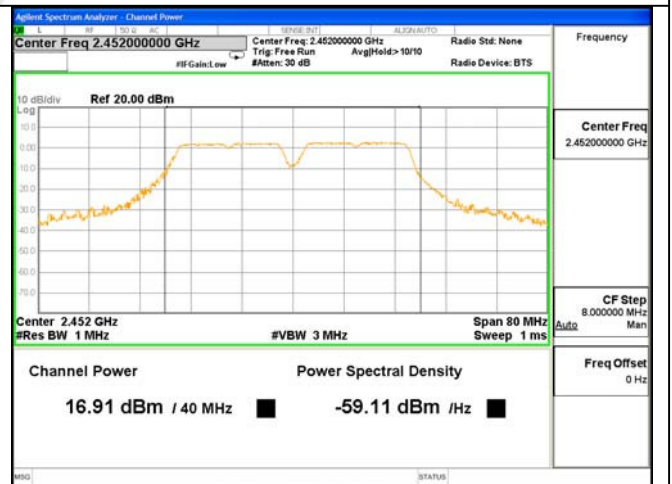

Test Mode: 802.11n40---High

4.4. Band Edges Measurement

a. Limit

According to §15.247(c), in any 100 kHz bandwidth outside the frequency bands in which the spread spectrum intentional radiator is operating, the radio frequency power that is produced by the intentional radiator shall be at least 20dB below that in the 100kHz bandwidth within the band that contains the highest level of the desired power, In addition, radiated emissions which fall in the restricted bands, as defined in §15.205(a), must also comply with the radiated emission limits specified in §15.209(a).

b. Test Procedure

1. Conducted Method:

- 1) Set RBW=100KHz, VBW=300KHz
- 2) Detector=peak
- 3) Sweep time= auto
- 4) Trace mode=max hold.

2. Radiated Method:

- 1) For below 1GHz: The EUT is placed on a turntable, which is 0.8m above the ground plane. The EUT is tested in 9*6*6 Chamber.
For above 1GHz: The EUT is placed on a turntable, which is 1.5m above the ground plane. The EUT is tested in 9*6*6 Chamber.
- 2) The turntable shall be rotated for 360 degrees to determine the position of maximum emission level.
- 3) EUT is set 3m away from the receiving antenna, which is varied from 1m to 4m to find out the highest emission.
- 4) Peak detector: RBW=1MHz, VBW=3MHz, SWT=AUTO
Average detector: RBW=1MHz, VBW=10Hz, SWT=AUTO
The EUT is tested in 9*6*6 Chamber.
- 5) Repeat the procedures until all the PEAK and AVERAGE versus POLARIZATION are measured.

30M to 1G emissions:

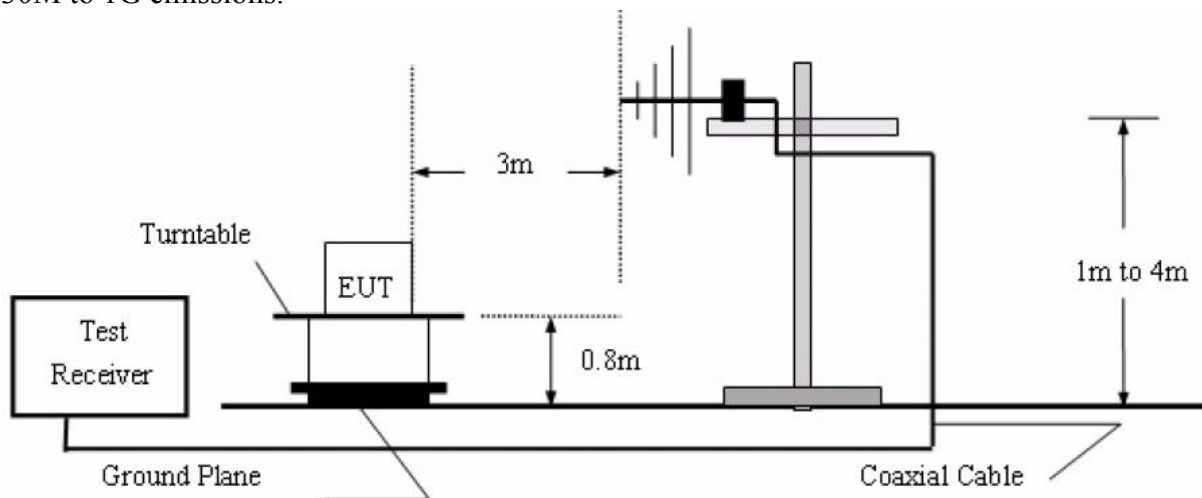

1G to 40G emissions:

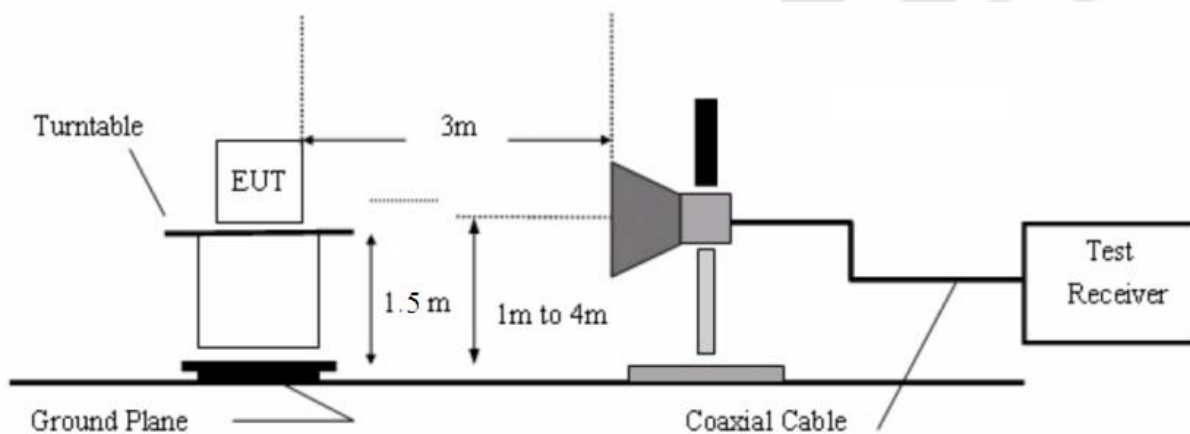

c. Test Equipment

Same as the equipment listed in 4.2.

d. Test Results

Pass.

e. Test Plots

See the following page.

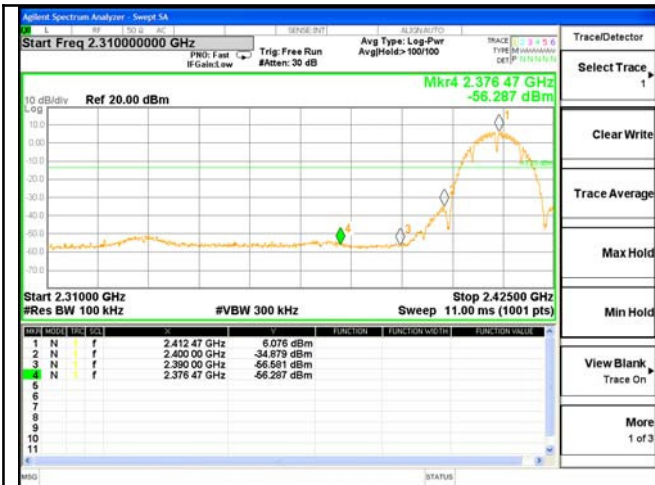

Test Mode: 802.11b---Low



Test Mode: 802.11b---High



Test Mode: 802.11g---Low



Test Mode: 802.11g---High



Test Mode: 802.11n20---Low

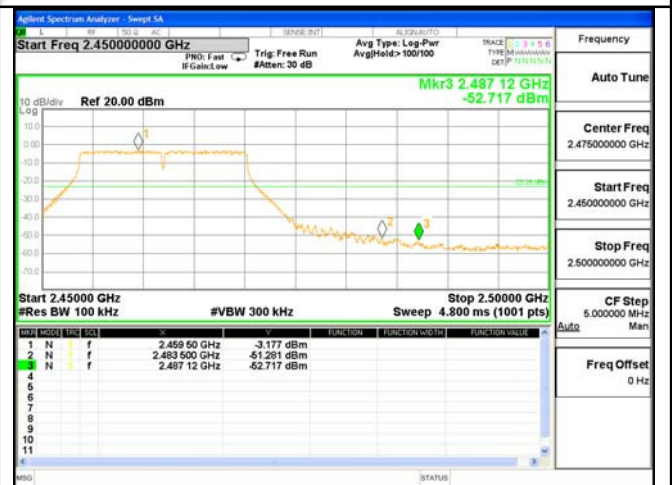

Test Mode: 802.11n20---High

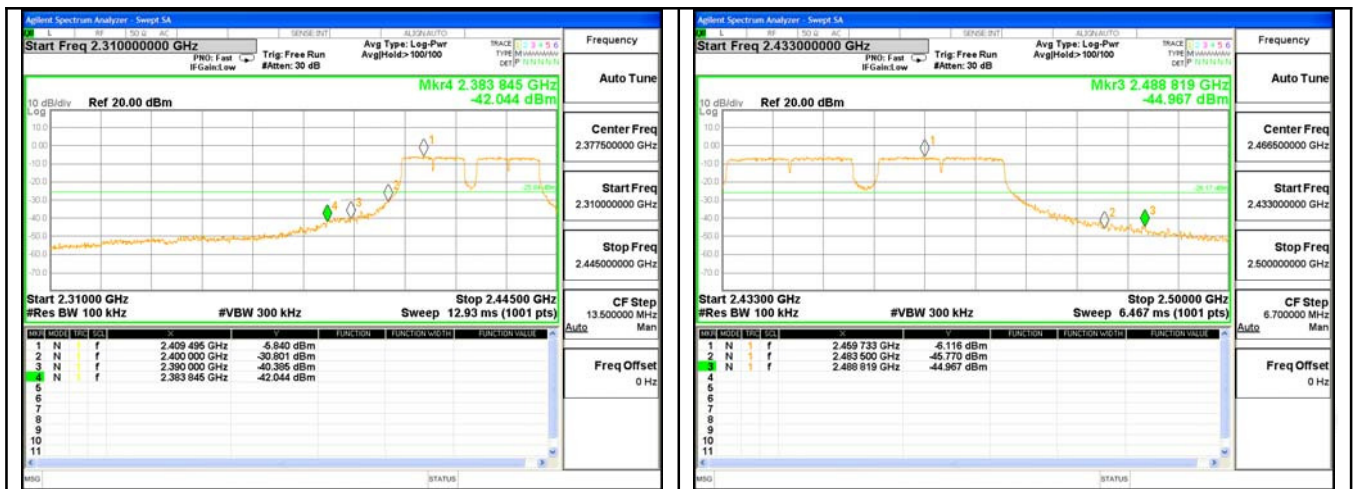

Test Mode: 802.11n40---Low

Test Mode: 802.11n40---High



Test Mode: 802.11b
2412MHz
Horizontal-PEAK:

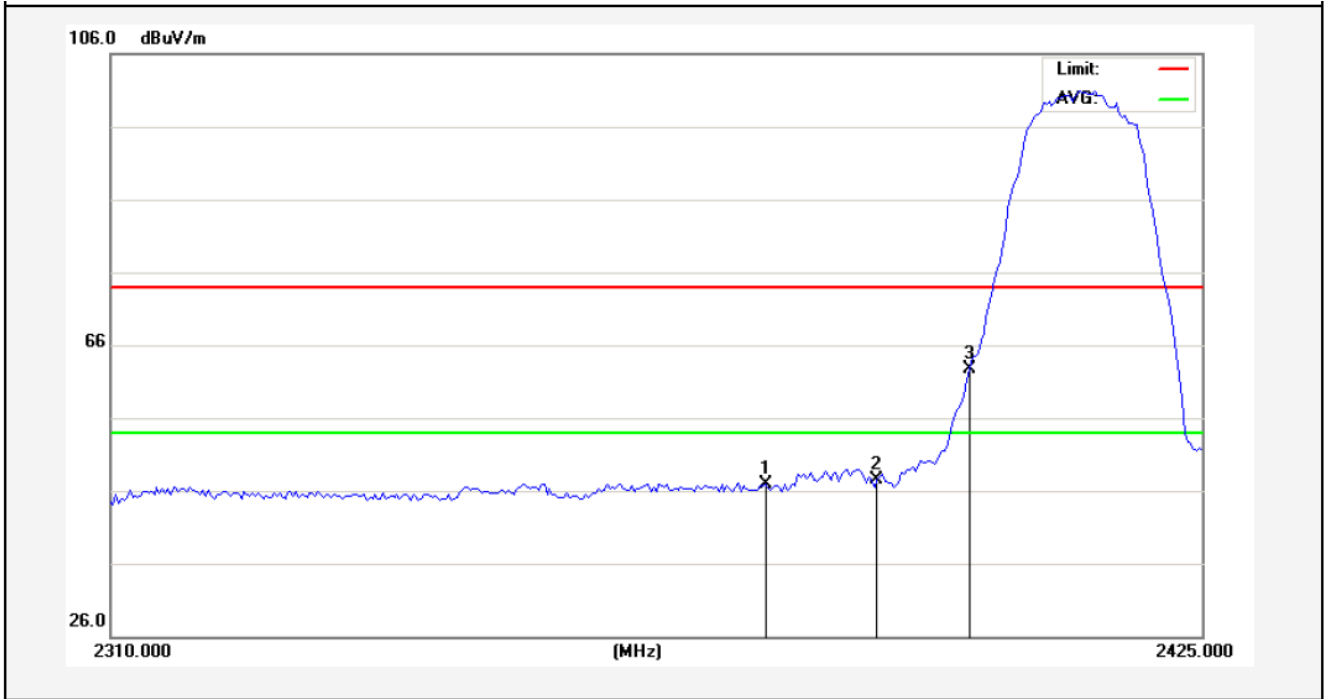

Frequency	CableLoss	AntFactor	PreampFactor	ReadLevel	Level	Limit	Over Limit	Remark
MHz	dB	dB/m	dB	dBμV	dBμV/m	dBμV/m	dB	
2378.425	2.16	30.38	31.47	45.78	46.85	74.00	-27.15	Peak
2390.000	2.21	30.38	31.47	46.29	47.41	74.00	-26.59	Peak
2400.000	2.22	30.38	31.47	61.50	62.63	74.00	-11.37	Peak

Horizontal-AV:

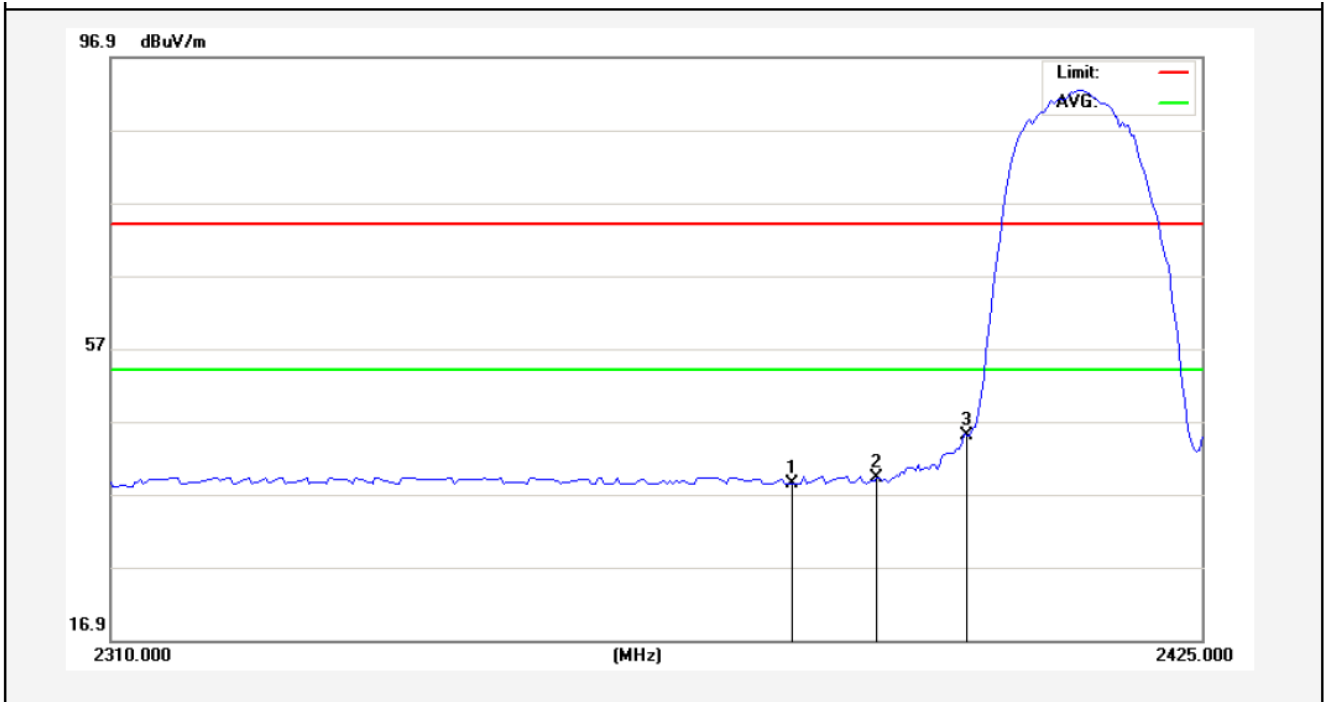

Frequency	CableLoss	AntFactor	Preamplifier	ReadLevel	Level	Limit	Over Limit	Remark
MHz	dB	dB/m	dB	dBμV	dBμV/m	dBμV/m	dB	
2381.300	2.18	30.38	31.47	37.39	38.48	54.00	-15.52	AVG
2390.000	2.21	30.38	31.47	38.16	39.28	54.00	-14.72	AVG
2400.000	2.22	30.38	31.47	43.78	44.91	54.00	-9.09	AVG

AVG

Test Mode: 802.11b
2412MHz
Vertical-PEAK:

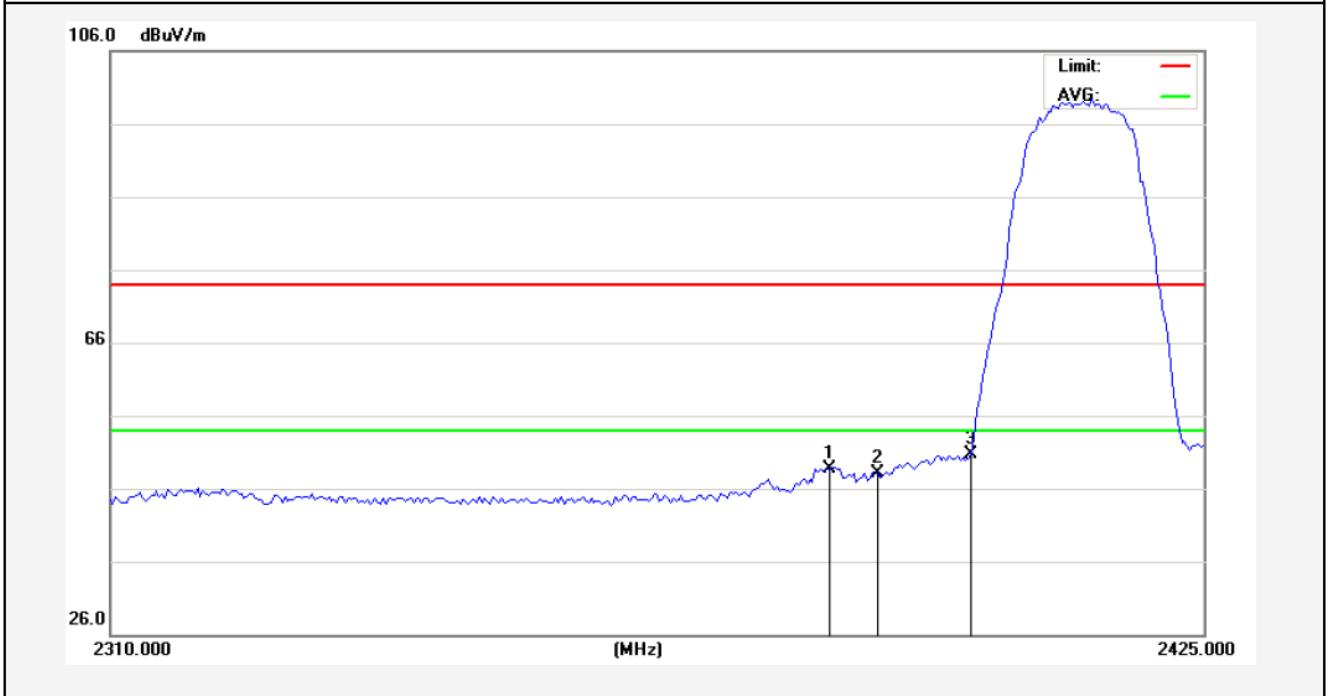

Frequency	CableLoss	AntFactor	PreampFactor	ReadLevel	Level	Limit	Over Limit	Remark
MHz	dB	dB/m	dB	dBuV	dBuV/m	dBuV/m	dB	
2385.037	2.19	30.38	31.47	47.68	48.78	74.00	-25.22	Peak
2390.000	2.21	30.38	31.47	47.07	48.19	74.00	-25.81	Peak
2400.000	2.22	30.38	31.47	49.65	50.78	74.00	-23.22	Peak

A M

Vertical-AV:

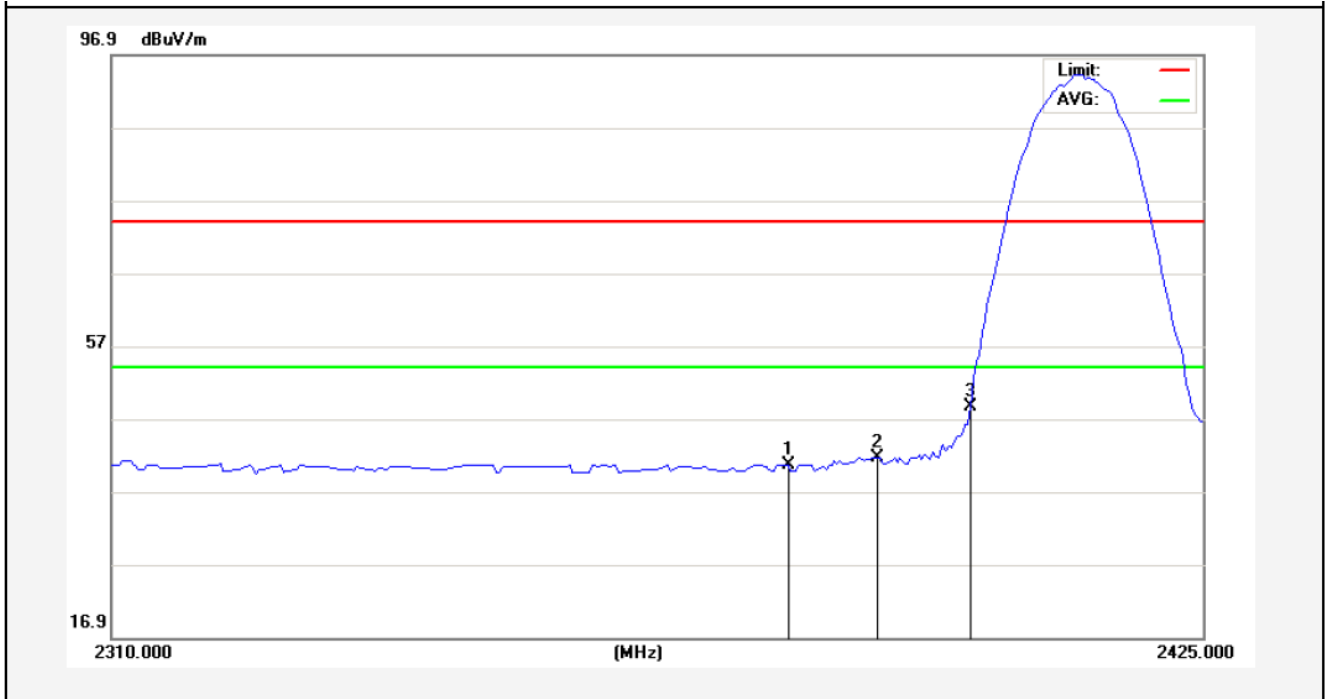

Frequency	CableLoss	AntFactor	Preamplifier	ReadLevel	Level	Limit	Over Limit	Remark
MHz	dB	dB/m	dB	dBμV	dBμV/m	dBμV/m	dB	
2380.725	2.18	30.38	31.47	39.61	40.70	54.00	-13.30	AVG
2390.000	2.21	30.38	31.47	40.51	41.63	54.00	-12.37	AVG
2400.000	2.22	30.38	31.47	47.49	48.62	54.00	-5.38	AVG

AVG

Test Mode: 802.11b
2462MHz
Horizontal-PEAK:

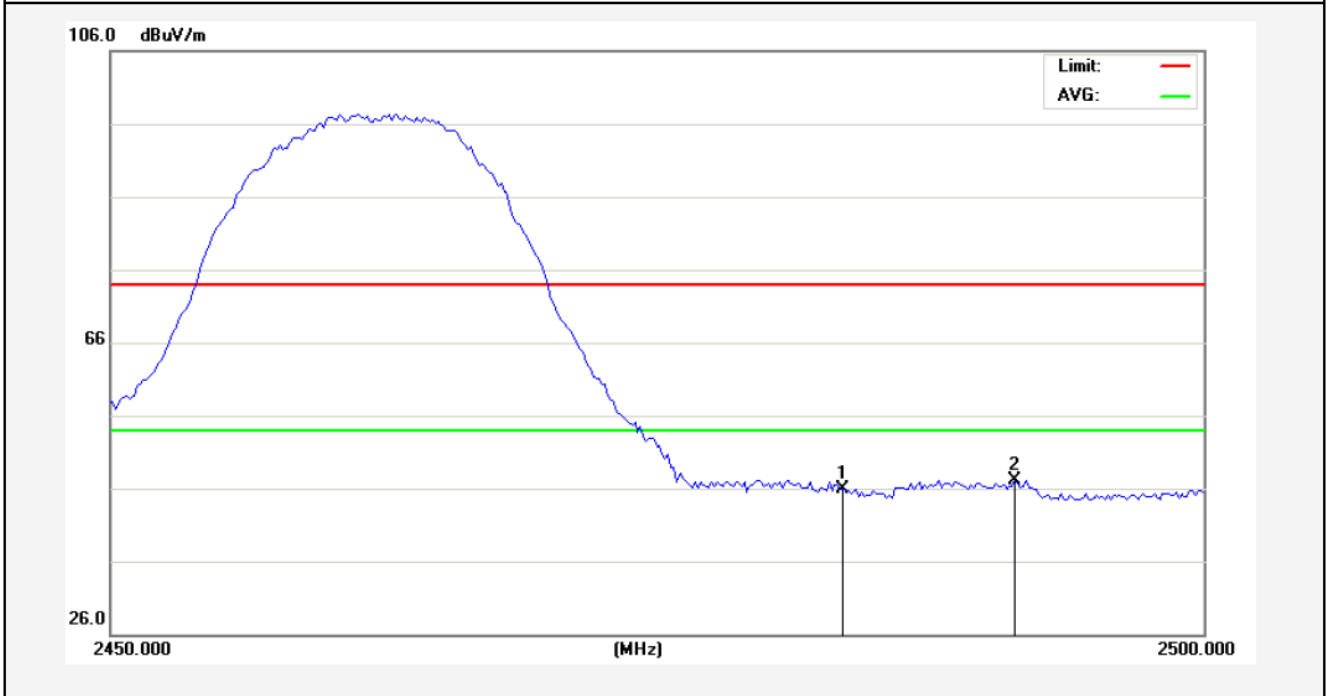

Frequency	CableLoss	AntFactor	PreampFactor	ReadLevel	Level	Limit	Over Limit	Remark
MHz	dB	dB/m	dB	dBµV	dBµV/m	dBµV/m	dB	
2483.500	2.35	30.38	31.47	44.64	45.90	74.00	-28.10	Peak
2491.375	2.38	30.38	31.47	45.75	47.04	74.00	-26.96	Peak

Anbotek

Horizontal-AV:

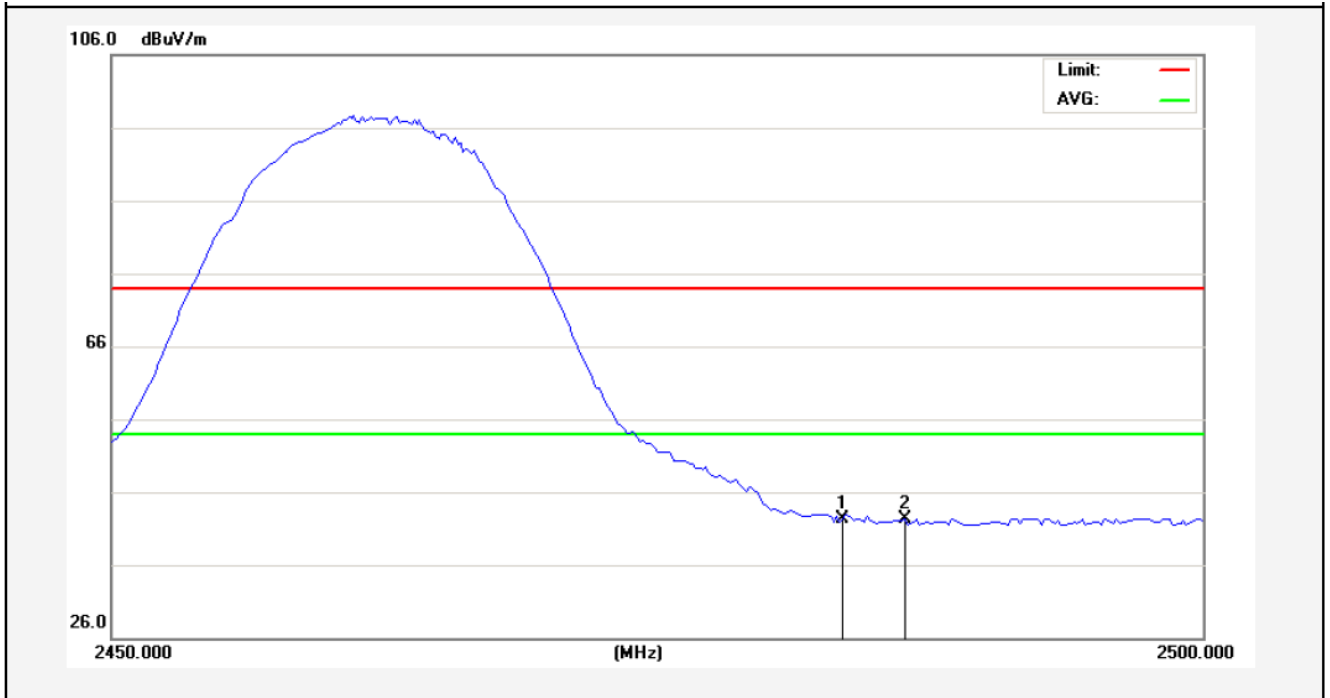

Frequency	CableLoss	AntFactor	Preamplifier	ReadLevel	Level	Limit	Over Limit	Remark
MHz	dB	dB/m	dB	dB μ V	dB μ V/m	dB μ V/m	dB	
2483.500	2.35	30.38	31.47	40.94	42.20	54.00	-11.80	AVG
2486.375	2.36	30.38	31.47	40.97	42.24	54.00	-11.76	AVG

Anbotek

Test Mode: 802.11b
2462MHz
Vertical-PEAK:

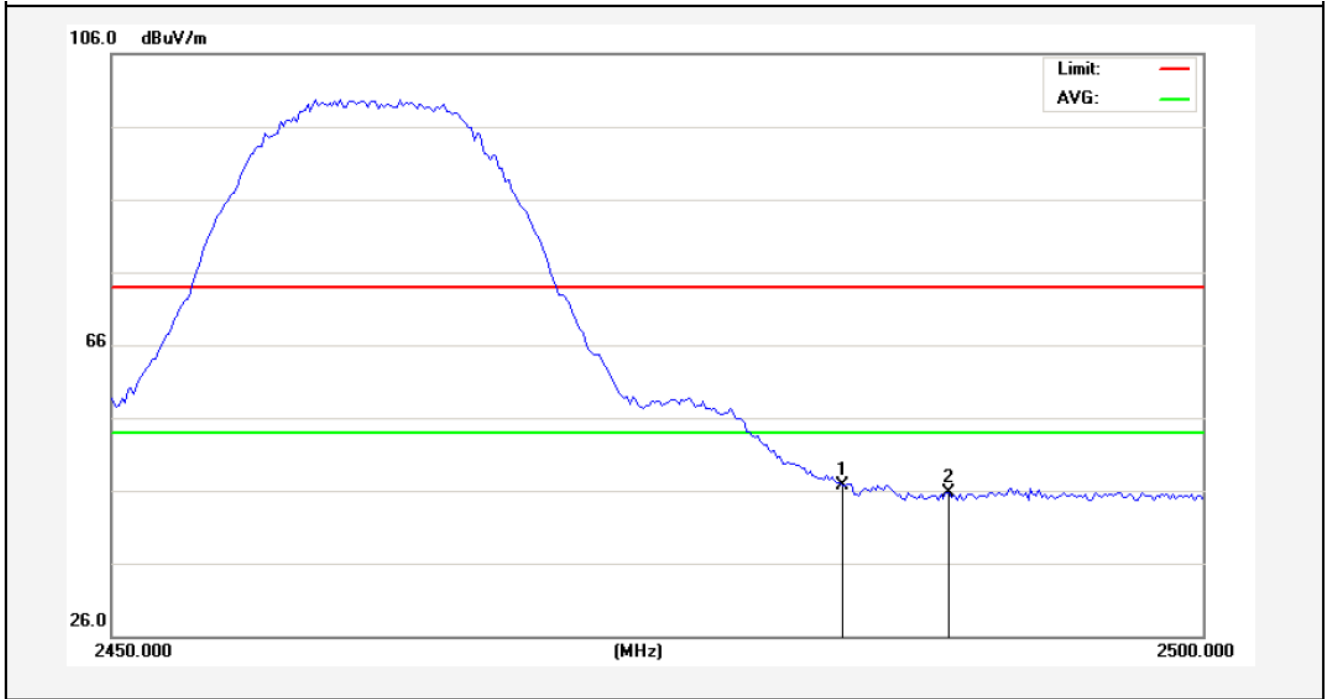

Frequency	CableLoss	AntFactor	PreampFactor	ReadLevel	Level	Limit	Over Limit	Remark
MHz	dB	dB/m	dB	dBμV	dBμV/m	dBμV/m	dB	
2483.500	2.35	30.38	31.47	45.35	46.61	74.00	-27.39	Peak
2488.375	2.37	30.38	31.47	44.37	45.65	74.00	-28.35	Peak

AMC

Vertical-AV:

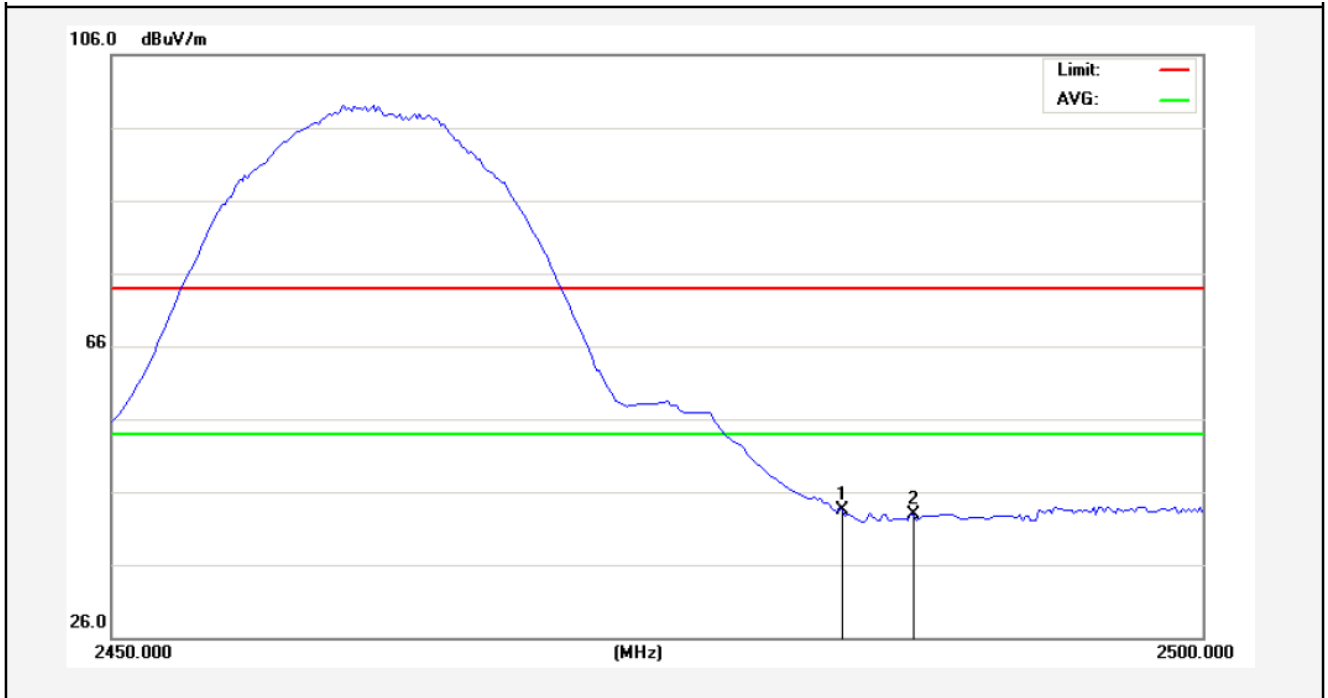

Frequency	CableLoss	AntFactor	Preamplifier	ReadLevel	Level	Limit	Over Limit	Remark
MHz	dB	dB/m	dB	dBμV	dBμV/m	dBμV/m	dB	
2483.500	2.35	30.38	31.47	42.30	43.56	54.00	-10.44	AVG
2486.750	2.36	30.38	31.47	41.72	42.99	54.00	-11.01	AVG

Anbotek

Test Mode: 802.11g
2412MHz
Horizontal-PEAK:

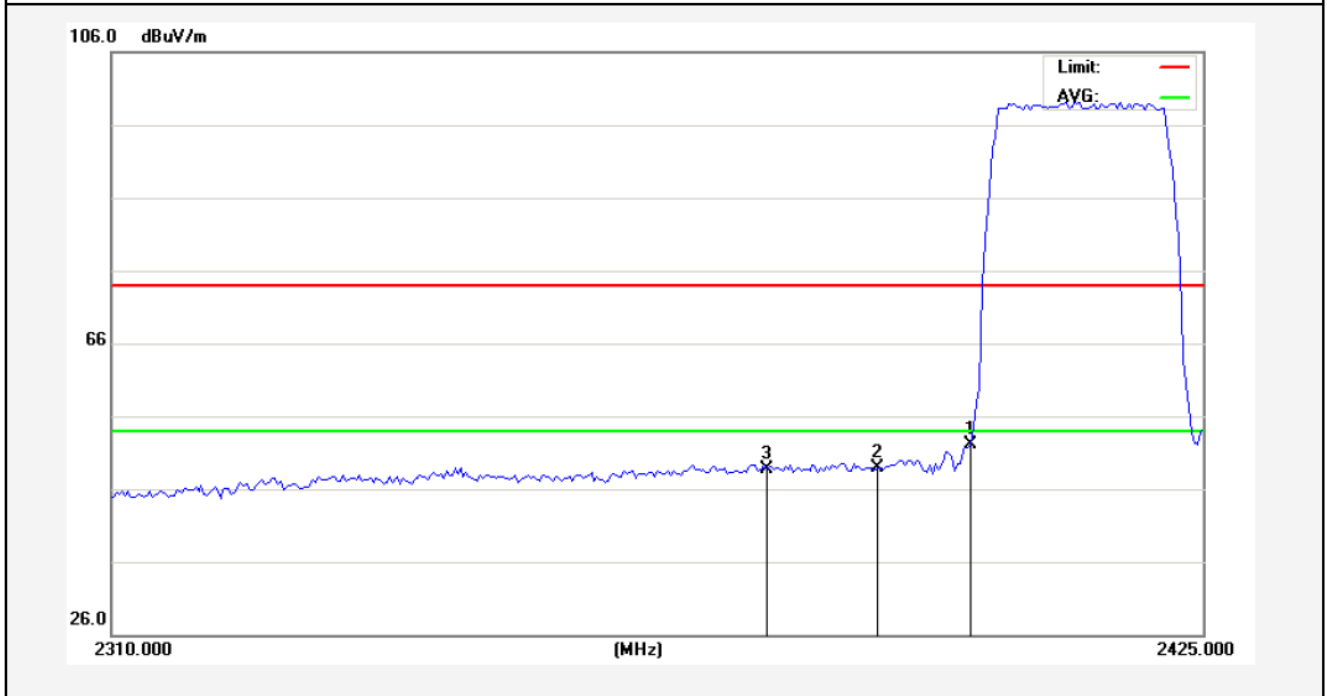

Frequency	CableLoss	AntFactor	PreampFactor	ReadLevel	Level	Limit	Over Limit	Remark
MHz	dB	dB/m	dB	dBμV	dBμV/m	dBμV/m	dB	
2400.000	2.22	30.38	31.47	50.90	52.03	74.00	-21.97	Peak
2390.000	2.21	30.38	31.47	47.70	48.82	74.00	-25.18	Peak
2378.425	2.17	30.38	31.47	47.71	48.79	74.00	-25.21	Peak

AMC

Horizontal-AV:

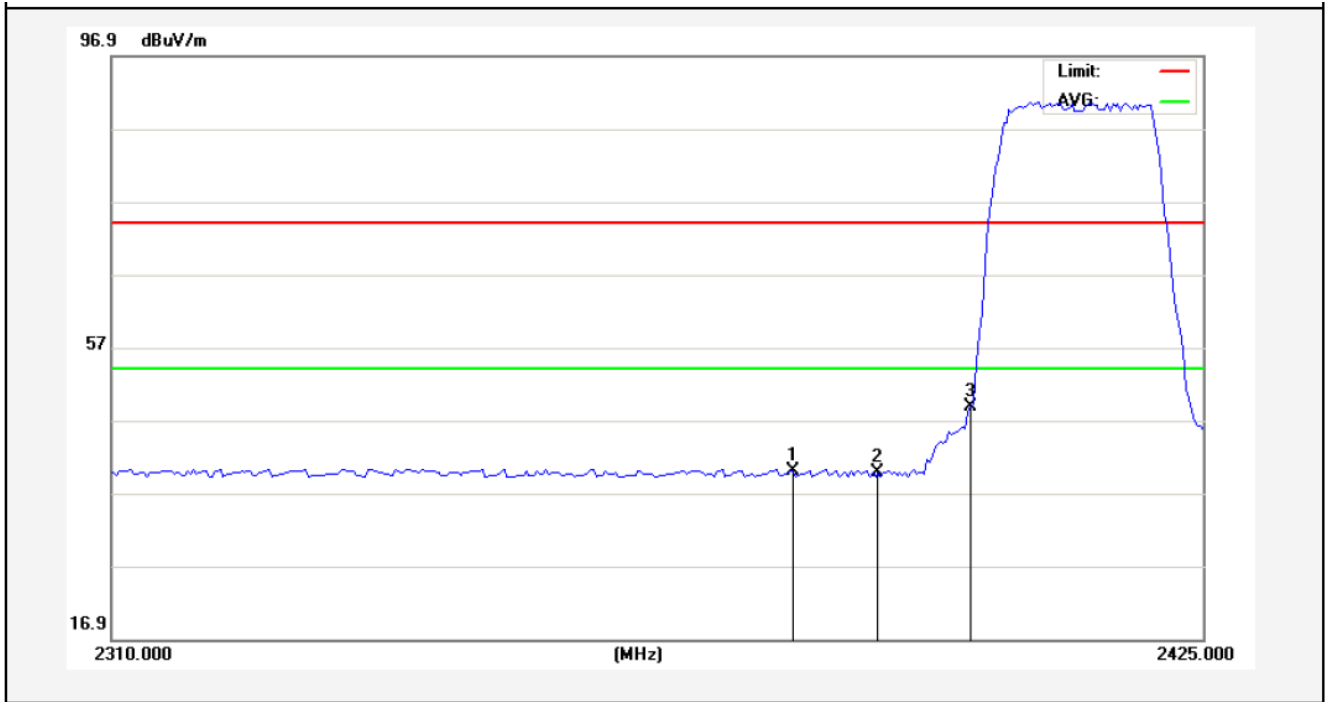

Frequency	CableLoss	AntFactor	PreampFactor	ReadLevel	Level	Limit	Over Limit	Remark
MHz	dB	dB/m	dB	dB μ V	dB μ V/m	dB μ V/m	dB	
2381.300	2.18	30.38	31.47	38.90	39.99	54.00	-14.01	AVG
2390.000	2.21	30.38	31.47	38.72	39.84	54.00	-14.16	AVG
2400.000	2.22	30.38	31.47	47.71	48.84	54.00	-5.16	AVG

AVG

Test Mode: 802.11g
2412MHz
Vertical-PEAK:

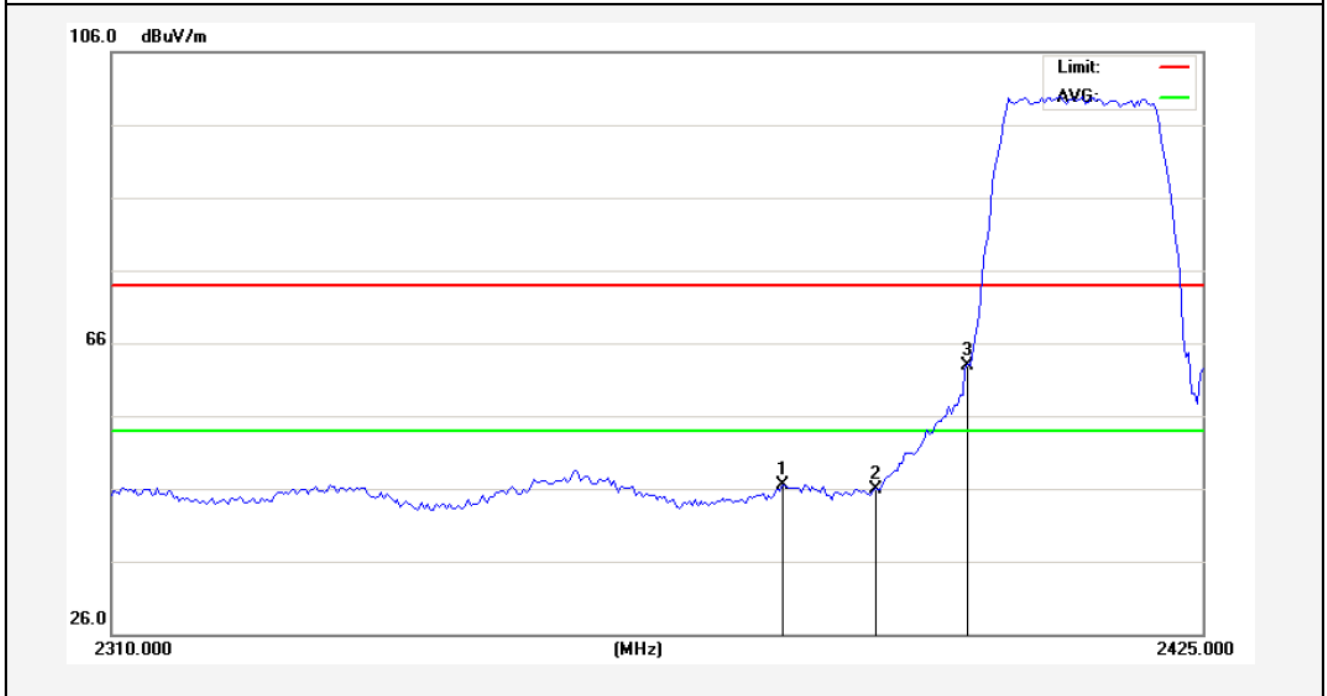

Frequency	CableLoss	AntFactor	Preamplifier	ReadLevel	Level	Limit	Over Limit	Remark
MHz	dB	dB/m	dB	dBμV	dBμV/m	dBμV/m	dB	
2380.150	2.18	30.38	31.47	45.38	46.47	74.00	-27.53	Peak
2390.000	2.21	30.38	31.47	44.79	45.91	74.00	-28.09	Peak
2400.000	2.22	30.38	31.47	61.81	62.94	74.00	-11.06	Peak

AMR

Vertical-AV:

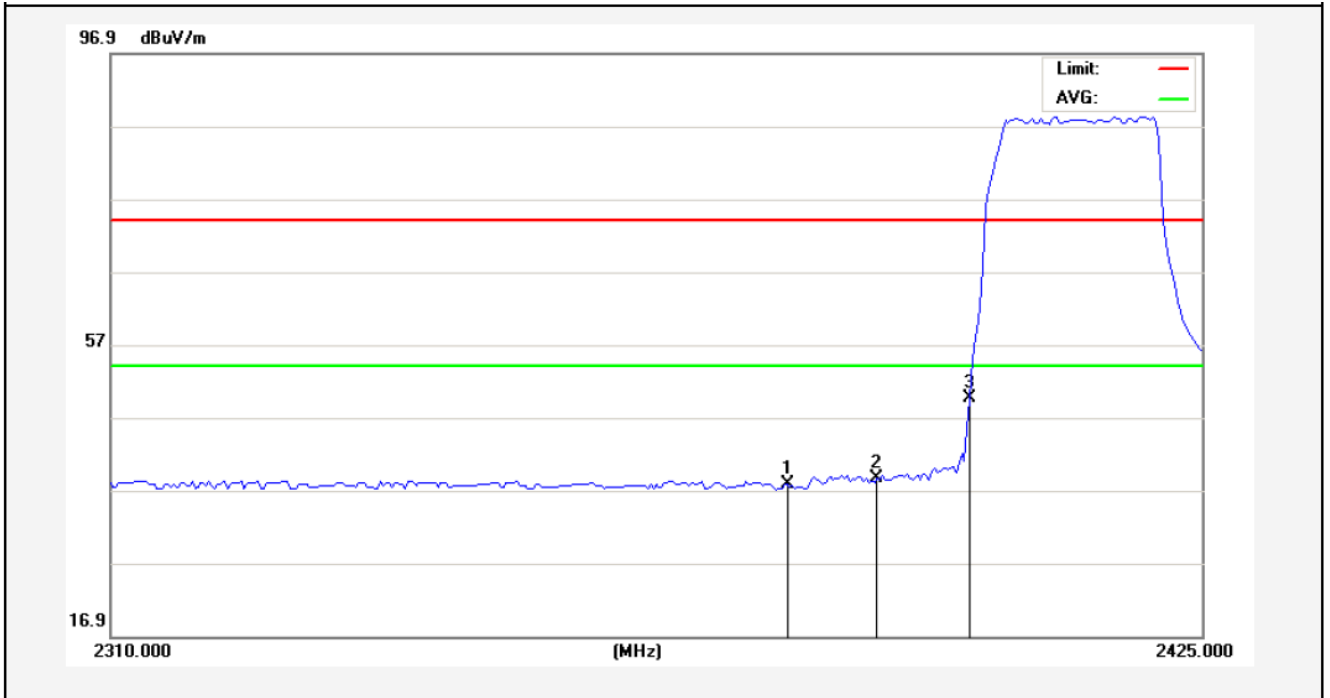

Frequency	CableLoss	AntFactor	Preamplifier	ReadLevel	Level	Limit	Over Limit	Remark
MHz	dB	dB/m	dB	dBμV	dBμV/m	dBμV/m	dB	
2380.725	2.18	30.38	31.47	36.80	37.89	54.00	-16.11	AVG
2390.000	2.21	30.38	31.47	37.50	38.62	54.00	-15.38	AVG
2400.000	2.22	30.38	31.47	48.40	49.53	54.00	-4.47	AVG

AVG

Test Mode: 802.11g
2462MHz
Horizontal-PEAK:

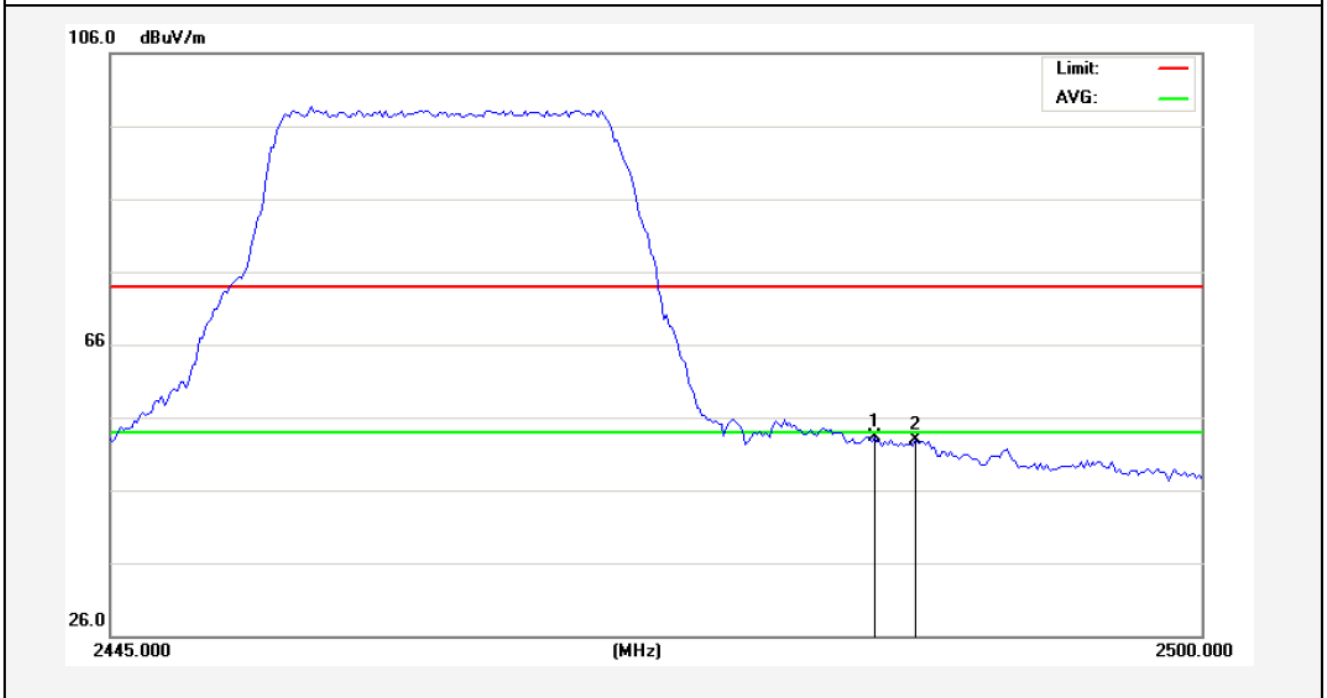

Frequency	CableLoss	AntFactor	PreampFactor	ReadLevel	Level	Limit	Over Limit	Remark
MHz	dB	dB/m	dB	dBuV	dBuV/m	dBuV/m	dB	
2483.500	2.35	30.38	31.47	51.99	53.25	74.00	-20.75	Peak
2485.563	2.36	30.38	31.47	51.54	52.81	74.00	-21.19	Peak

ANB

Horizontal-AV:

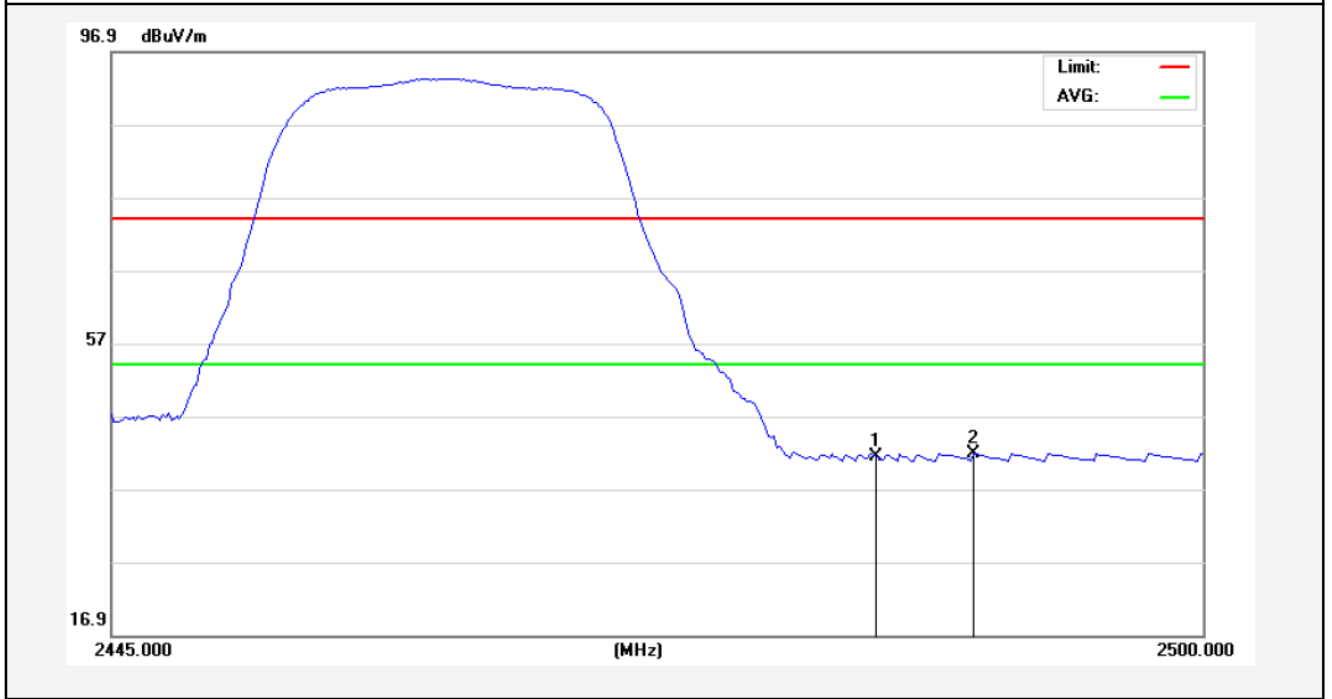

Frequency	CableLoss	AntFactor	PreampFactor	ReadLevel	Level	Limit	Over Limit	Remark
MHz	dB	dB/m	dB	dBμV	dBμV/m	dBμV/m	dB	
2483.500	2.35	30.38	31.47	40.19	41.45	54.00	-12.55	AVG
2488.450	2.37	30.38	31.47	40.47	41.75	54.00	-12.25	AVG

Anbotek

Test Mode: 802.11g
2462MHz
Vertical-PEAK:

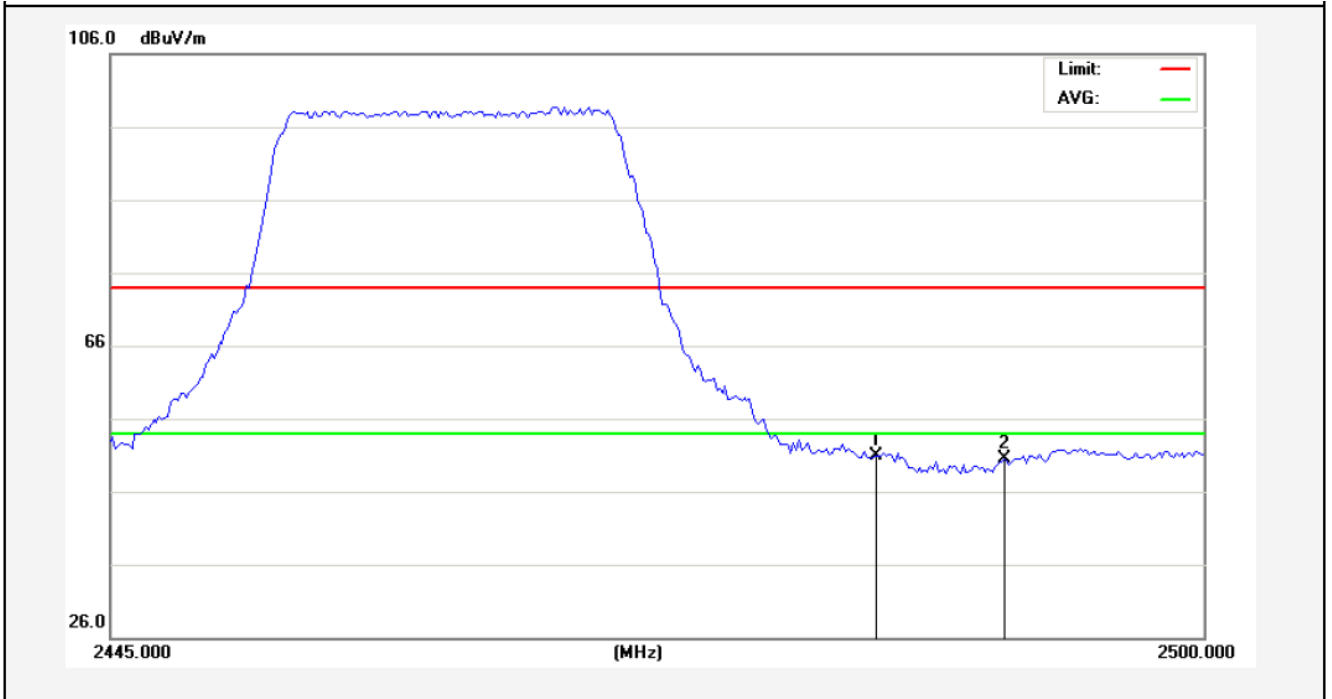

Frequency	CableLoss	AntFactor	PreampFactor	ReadLevel	Level	Limit	Over Limit	Remark
MHz	dB	dB/m	dB	dBµV	dBµV/m	dBµV/m	dB	
2483.500	2.35	30.38	31.47	49.62	50.88	74.00	-23.12	Peak
2489.963	2.37	30.38	31.47	49.16	50.44	74.00	-23.56	Peak

A.M.D.

Vertical-AV:

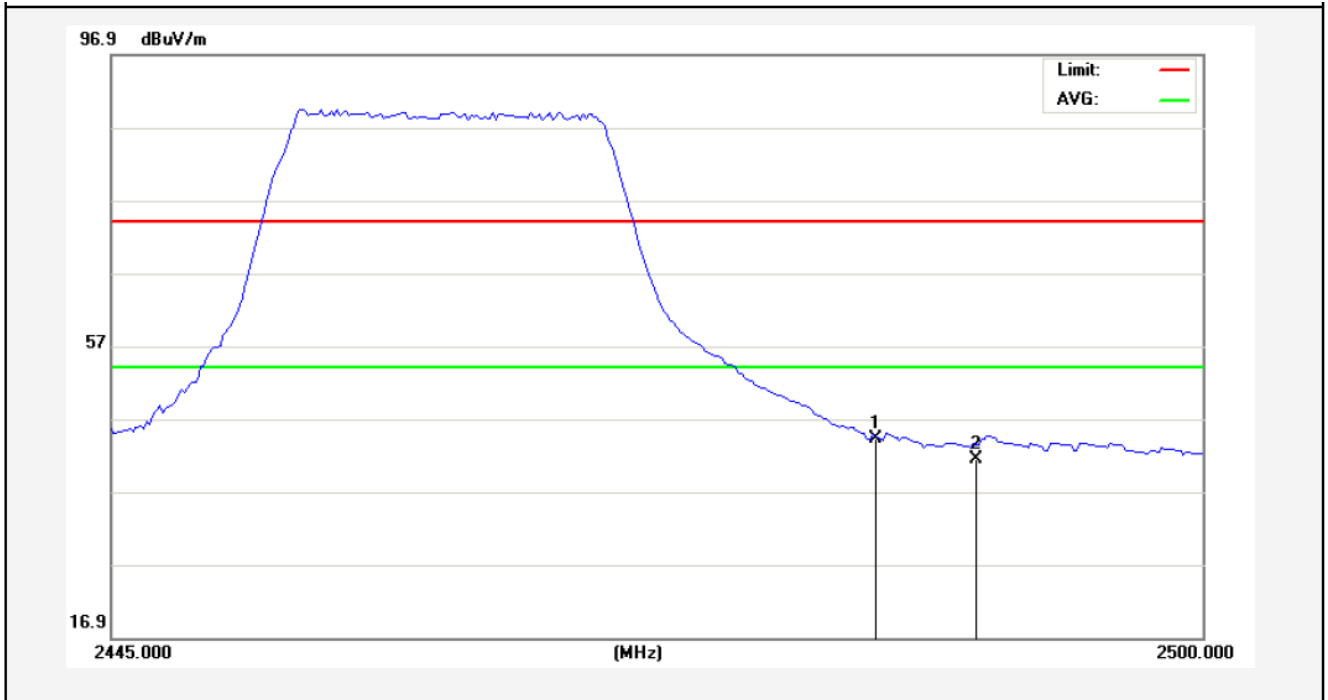

Frequency	CableLoss	AntFactor	Preamplifier	ReadLevel	Level	Limit	Over Limit	Remark
MHz	dB	dB/m	dB	dB μ V	dB μ V/m	dB μ V/m	dB	
2483.500	2.35	30.38	31.47	42.89	44.15	54.00	-9.85	AVG
2488.588	2.37	30.38	31.47	40.10	41.38	54.00	-12.62	AVG

Anbotek

Test Mode: 802.11n (HT20)

2412MHz

Horizontal-PEAK:

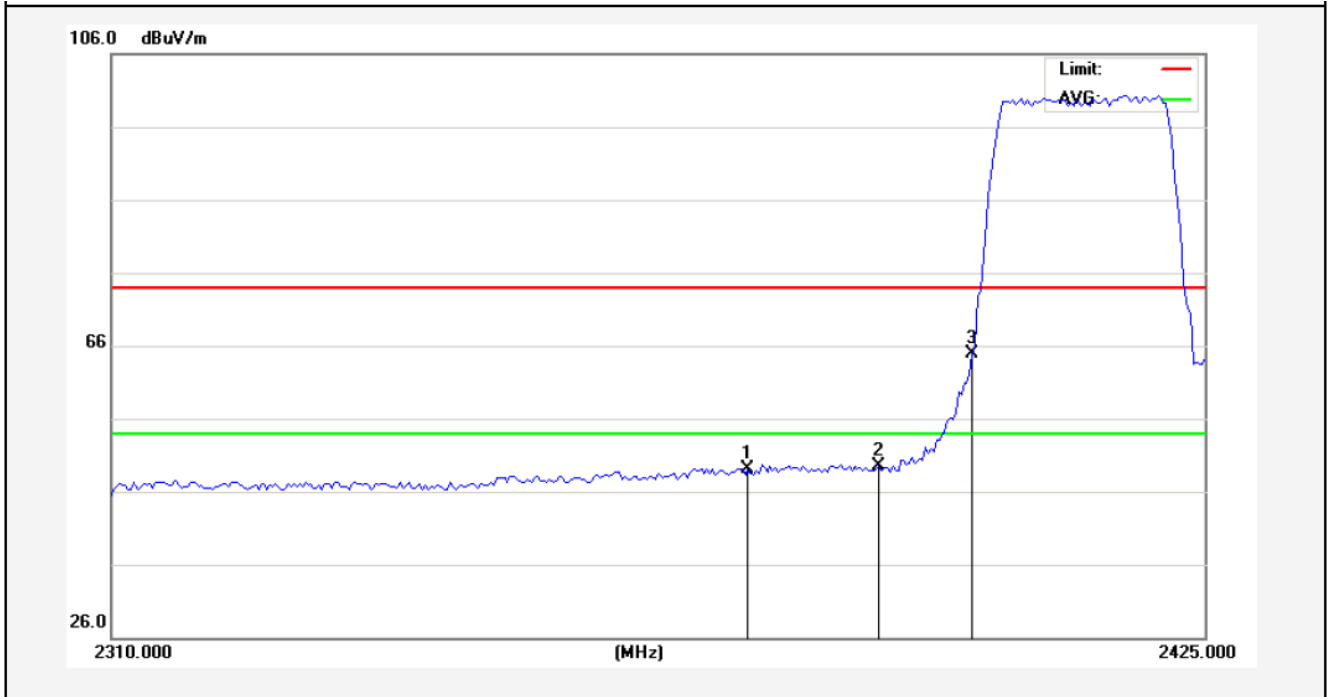

Frequency	CableLoss	AntFactor	PreampFactor	ReadLevel	Level	Limit	Over Limit	Remark
MHz	dB	dB/m	dB	dBμV	dBμV/m	dBμV/m	dB	
2376.412	2.16	30.38	31.47	48.02	49.09	74.00	-24.91	Peak
2390.000	2.21	30.38	31.47	48.34	49.46	74.00	-24.54	Peak
2400.000	2.22	30.38	31.47	63.72	64.85	74.00	-9.15	Peak

AMC

Horizontal-AV:

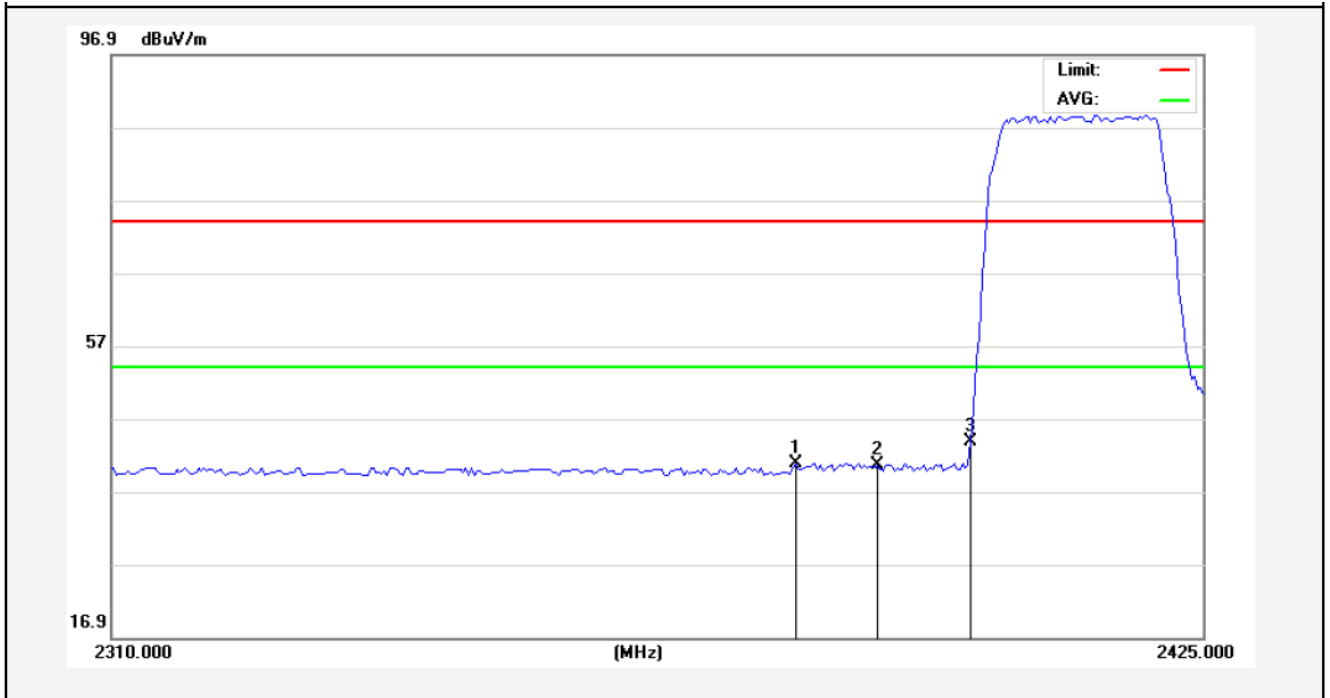

Frequency	CableLoss	AntFactor	Preamplifier	ReadLevel	Level	Limit	Over Limit	Remark
MHz	dB	dB/m	dB	dBμV	dBμV/m	dBμV/m	dB	
2381.588	2.18	30.38	31.47	39.65	40.74	54.00	-13.26	AVG
2390.000	2.21	30.38	31.47	39.43	40.55	54.00	-13.45	AVG
2400.000	2.22	30.38	31.47	42.65	43.78	54.00	-10.22	AVG

AVG

Test Mode: 802.11n (HT20)

2412MHz

Vertical-PEAK:

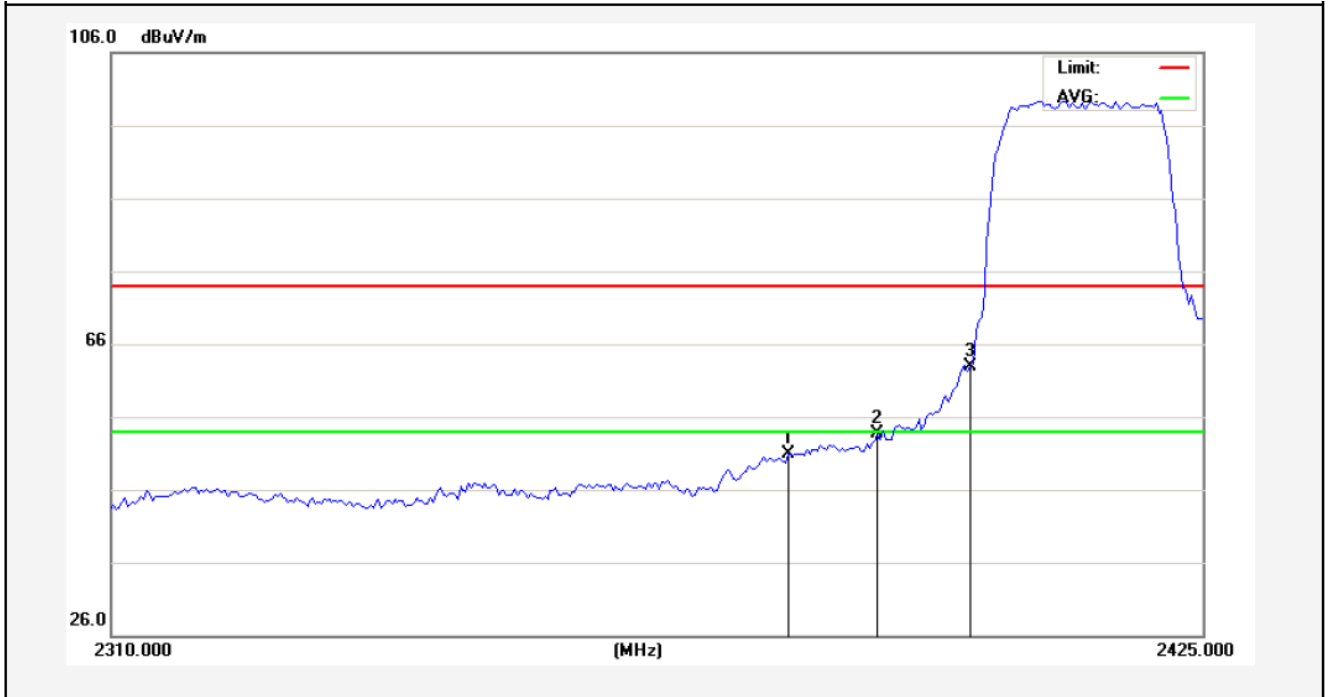

Frequency	CableLoss	AntFactor	PreampFactor	ReadLevel	Level	Limit	Over Limit	Remark
MHz	dB	dB/m	dB	dBμV	dBμV/m	dBμV/m	dB	
2380.725	2.18	30.38	31.47	49.84	50.93	74.00	-23.07	Peak
2390.000	2.21	30.38	31.47	52.54	53.66	74.00	-20.34	Peak
2400.000	2.22	30.38	31.47	61.87	63.00	74.00	-11.00	Peak

A.M.C.

Vertical-AV:

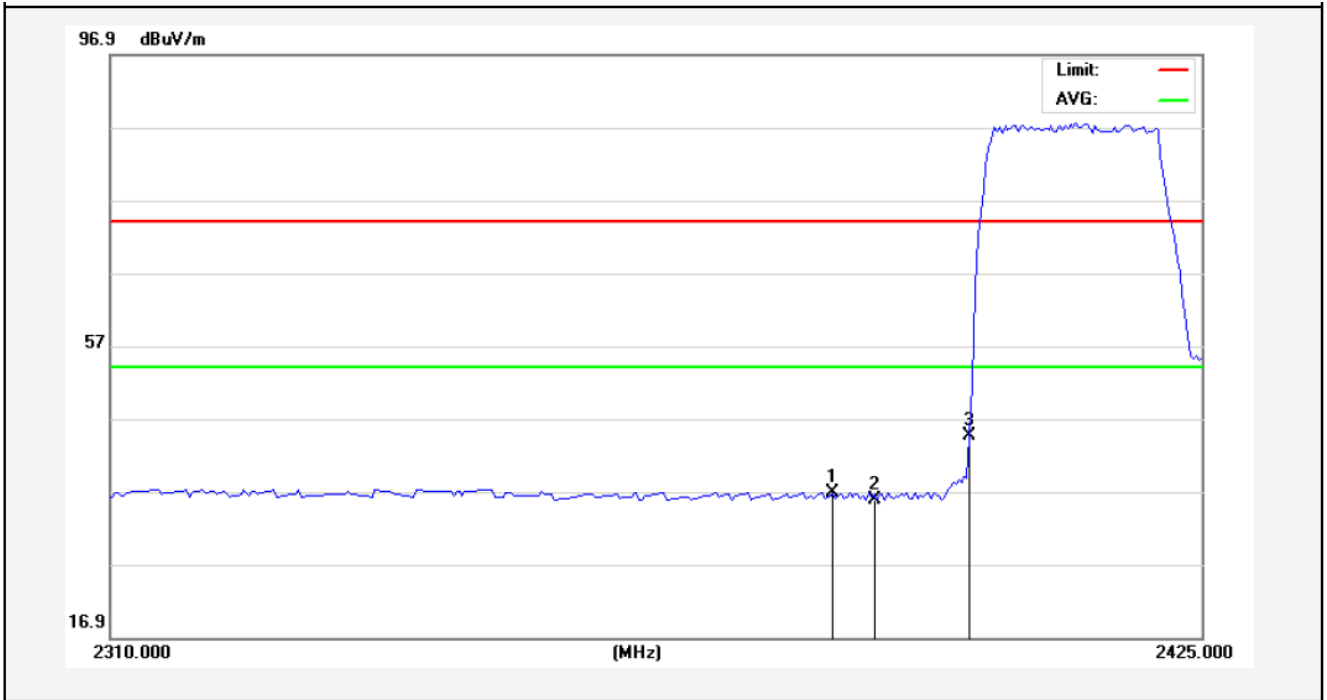

Frequency	CableLoss	AntFactor	Preamplifier	ReadLevel	Level	Limit	Over Limit	Remark
MHz	dB	dB/m	dB	dBμV	dBμV/m	dBμV/m	dB	
2385.613	2.19	30.38	31.47	35.68	36.78	54.00	-17.22	AVG
2390.000	2.21	30.38	31.47	34.77	35.89	54.00	-18.11	AVG
2400.000	2.22	30.38	31.47	43.44	44.57	54.00	-9.43	AVG

AVC

Test Mode: 802.11n (HT20)

2462MHz

Horizontal-PEAK:

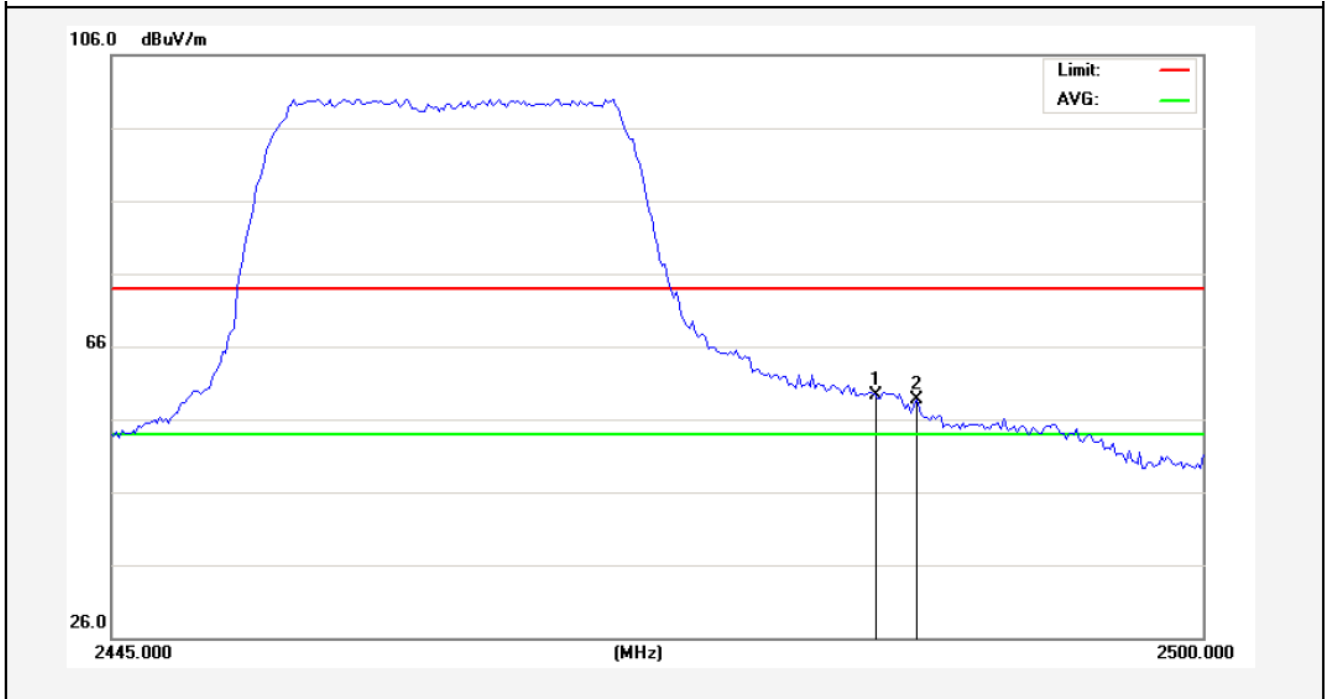

Frequency	CableLoss	AntFactor	PreampFactor	ReadLevel	Level	Limit	Over Limit	Remark
MHz	dB	dB/m	dB	dBμV	dBμV/m	dBμV/m	dB	
2483.500	2.35	30.38	31.47	58.04	59.30	74.00	-14.70	Peak
2485.563	2.35	30.38	31.47	57.49	58.75	74.00	-15.25	Peak

A M B

Horizontal-AV:

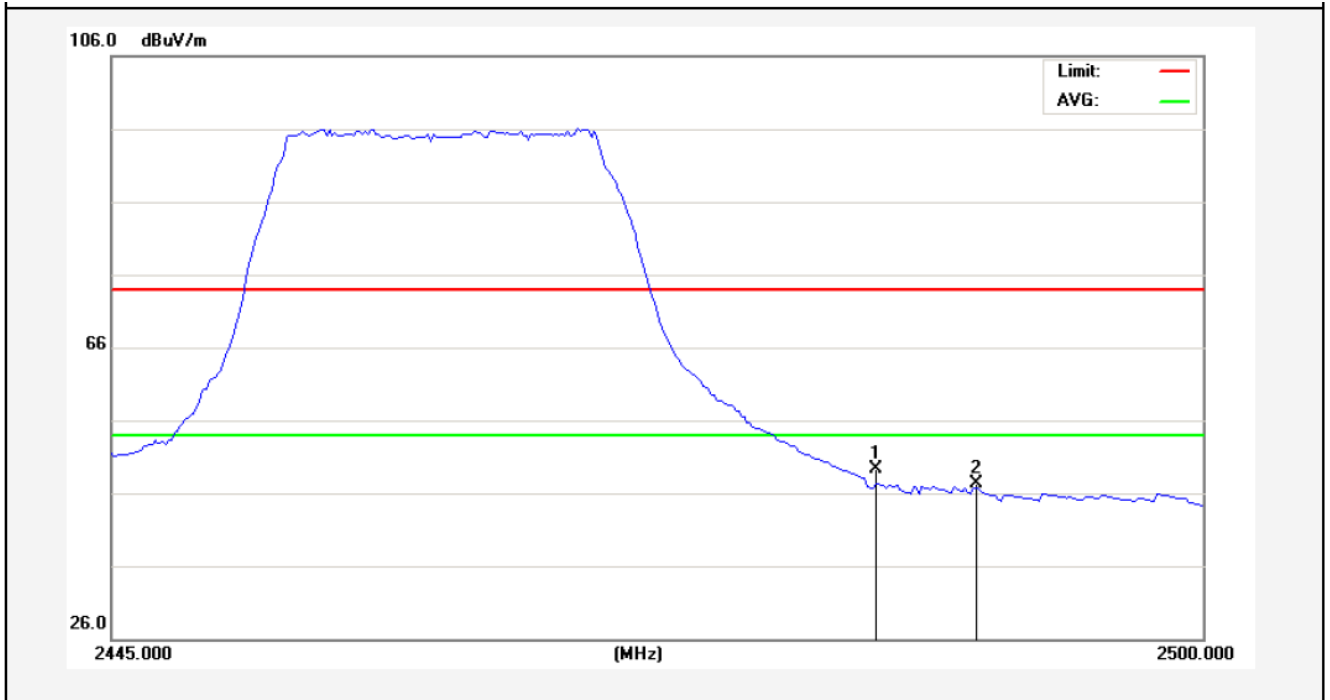

Frequency	CableLoss	AntFactor	Preamplifier	ReadLevel	Level	Limit	Over Limit	Remark
MHz	dB	dB/m	dB	dBμV	dBμV/m	dBμV/m	dB	
2483.500	2.35	30.38	31.47	48.12	49.38	54.00	-4.62	AVG
2488.588	2.37	30.38	31.47	45.98	47.26	54.00	-6.74	AVG

Anbotek

Test Mode: 802.11n (HT20)

2462MHz

Vertical-PEAK:

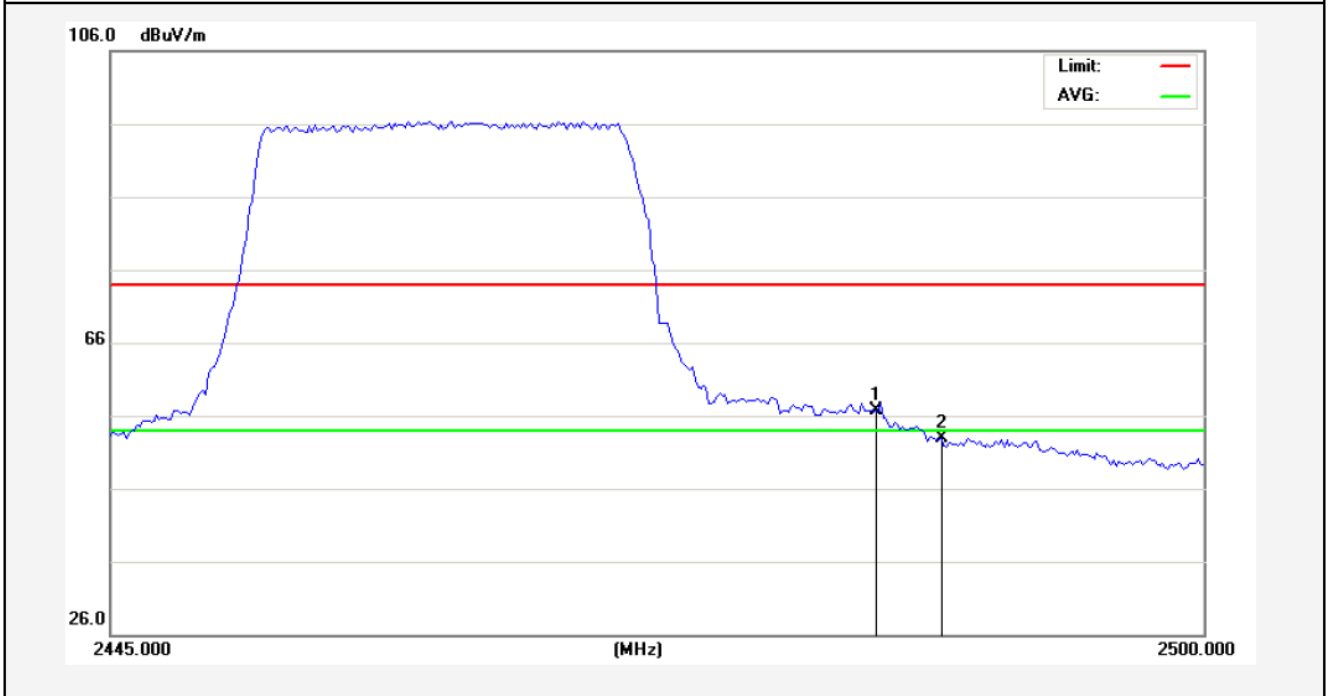

Frequency	CableLoss	AntFactor	PreampFactor	ReadLevel	Level	Limit	Over Limit	Remark
MHz	dB	dB/m	dB	dB μ V	dB μ V/m	dB μ V/m	dB	
2483.500	2.35	30.38	31.47	55.49	56.75	74.00	-17.25	Peak
2486.800	2.36	30.38	31.47	51.56	52.83	74.00	-21.17	Peak

A M U

Vertical-AV:

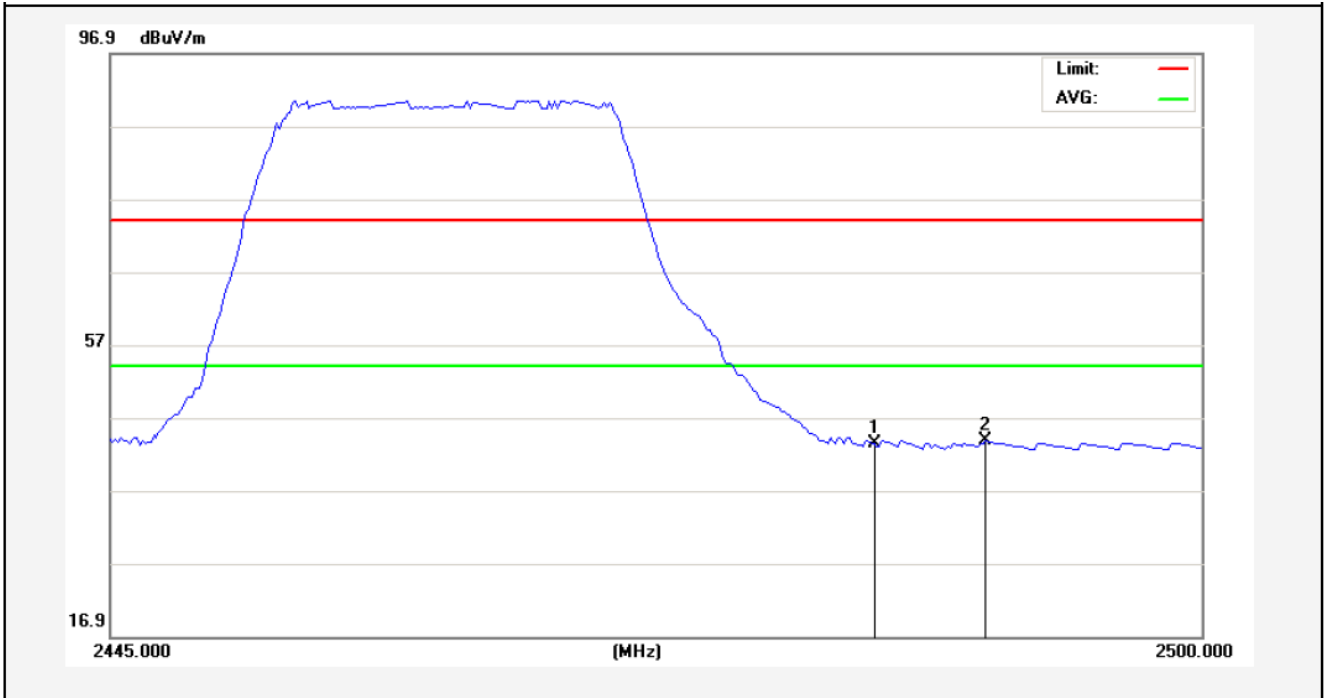

Frequency	CableLoss	AntFactor	Preamplifier	ReadLevel	Level	Limit	Over Limit	Remark
MHz	dB	dB/m	dB	dBμV	dBμV/m	dBμV/m	dB	
2483.500	2.35	30.38	31.47	42.08	43.34	54.00	-10.66	AVG
2489.137	2.37	30.38	31.47	42.45	43.73	54.00	-10.27	AVG

Anbotek

Test Mode: 802.11n (HT40)

2422MHz

Horizontal-PEAK:

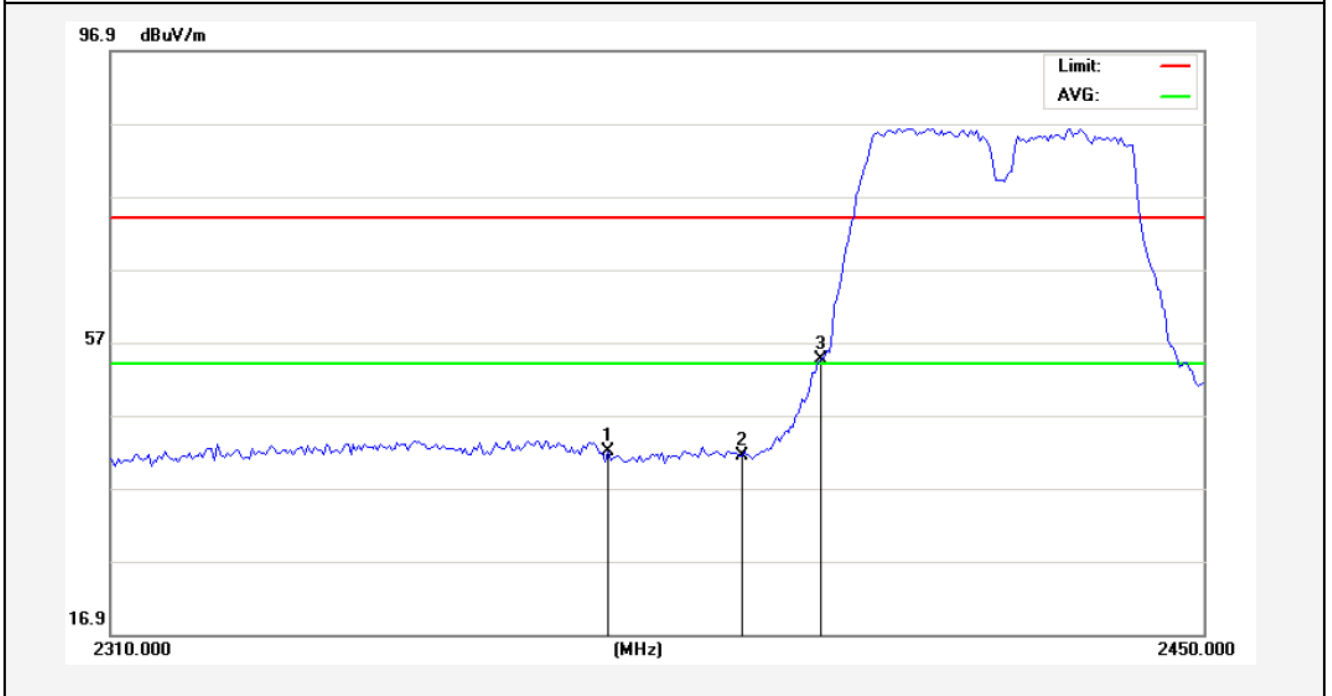

Frequency	CableLoss	AntFactor	PreampFactor	ReadLevel	Level	Limit	Over Limit	Remark
MHz	dB	dB/m	dB	dBμV	dBμV/m	dBμV/m	dB	
2373.000	2.15	30.38	31.47	40.86	41.92	74.00	-32.08	Peak
2390.000	2.21	30.38	31.47	40.23	41.35	74.00	-32.65	Peak
2400.000	2.22	30.38	31.47	53.54	54.67	74.00	-19.33	Peak

SAMPLE

Horizontal-AV:

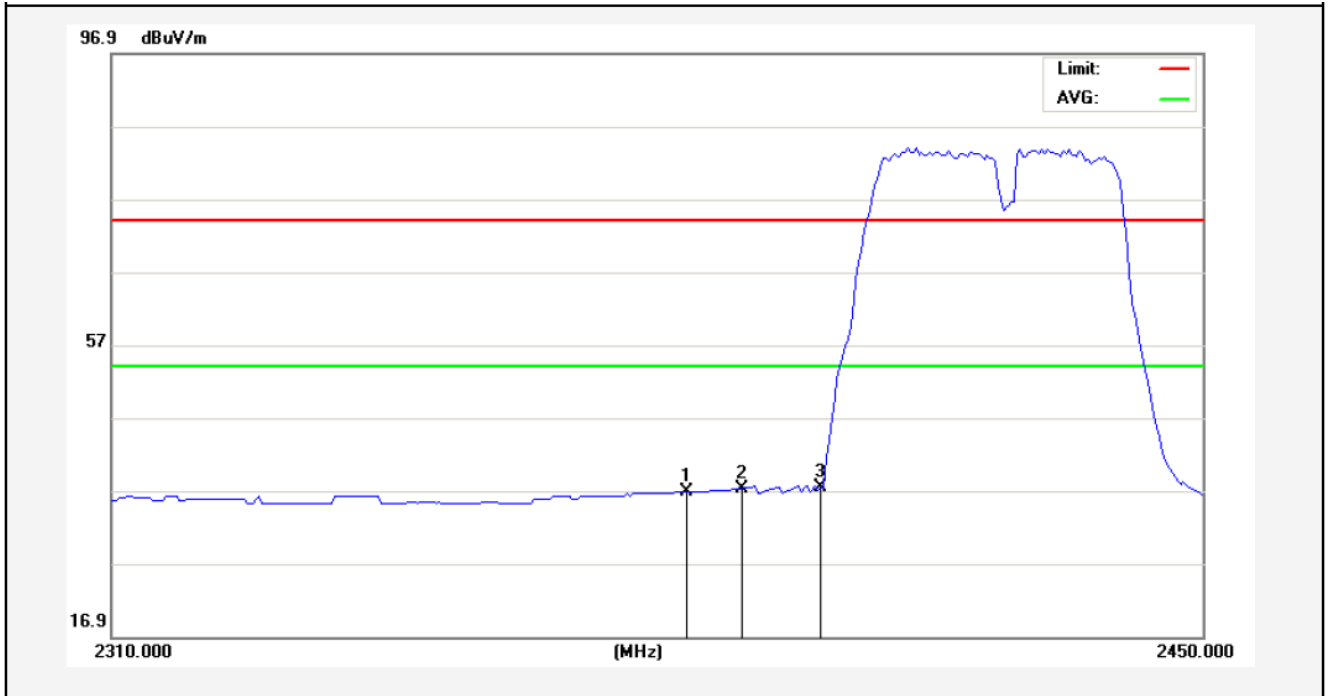

Frequency	CableLoss	AntFactor	Preamplifier	ReadLevel	Level	Limit	Over Limit	Remark
MHz	dB	dB/m	dB	dBμV	dBμV/m	dBμV/m	dB	
2383.150	2.18	30.38	31.47	35.71	36.80	54.00	-17.20	AVG
2390.000	2.21	30.38	31.47	36.12	37.24	54.00	-16.76	AVG
2400.000	2.22	30.38	31.47	36.22	37.35	54.00	-16.65	AVG

Anbotek

Test Mode: 802.11n (HT40)

2422MHz

Vertical-PEAK:

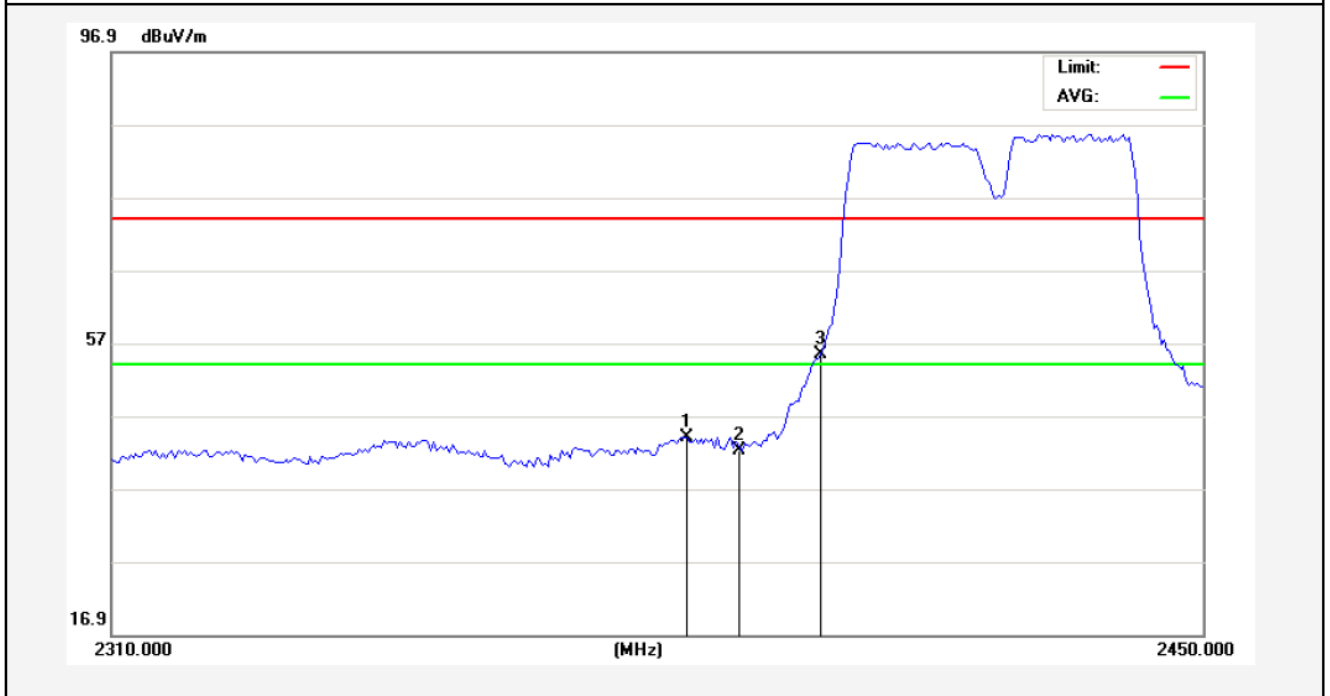

Frequency	CableLoss	AntFactor	PreampFactor	ReadLevel	Level	Limit	Over Limit	Remark
MHz	dB	dB/m	dB	dBμV	dBμV/m	dBμV/m	dB	
2383.150	2.18	30.38	31.47	42.98	44.07	74.00	-29.93	Peak
2390.000	2.21	30.38	31.47	41.14	42.26	74.00	-31.74	Peak
2400.000	2.22	30.38	31.47	54.31	55.44	74.00	-18.56	Peak

Anbotek

Vertical-AV:

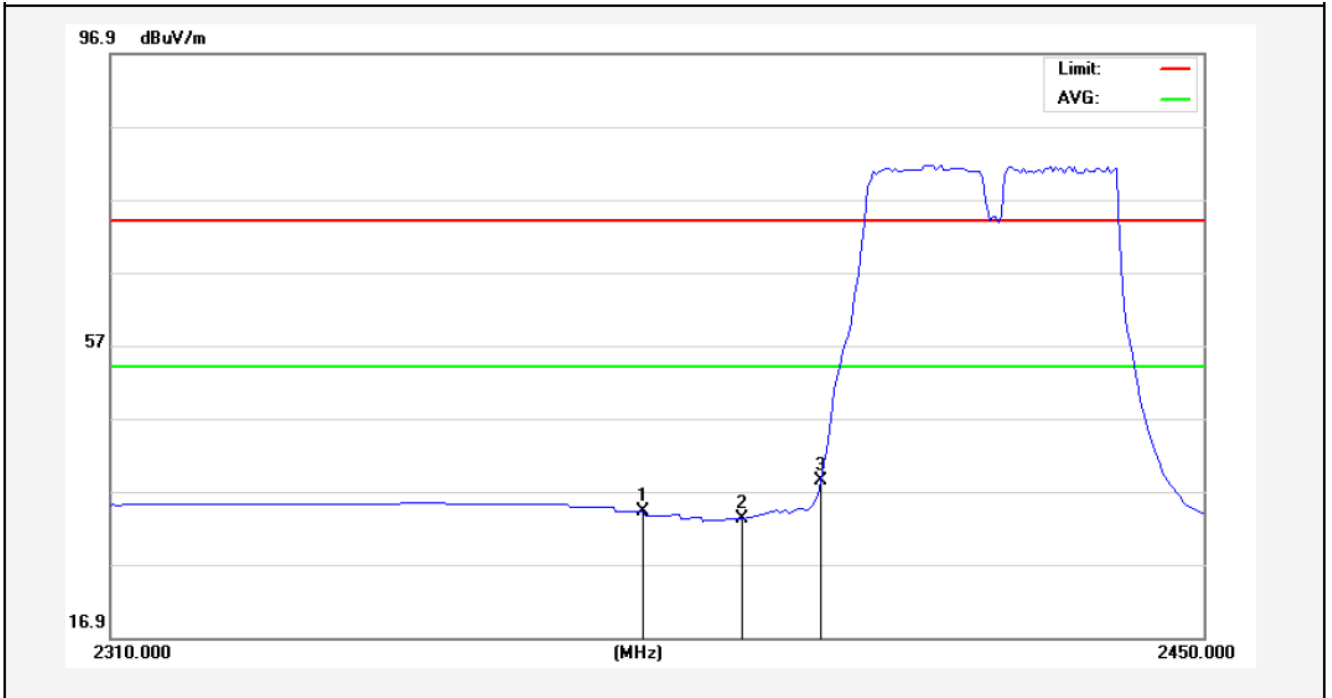

Frequency	CableLoss	AntFactor	Preamplifier	ReadLevel	Level	Limit	Over Limit	Remark
MHz	dB	dB/m	dB	dBμV	dBμV/m	dBμV/m	dB	
2377.550	2.17	30.38	31.47	33.06	34.14	54.00	-19.86	AVG
2390.000	2.21	30.38	31.47	32.13	33.25	54.00	-20.75	AVG
2400.000	2.22	30.38	31.47	37.24	38.37	54.00	-15.63	AVG

AVG

Test Mode: 802.11n (HT40)

2452MHz

Horizontal-PEAK:

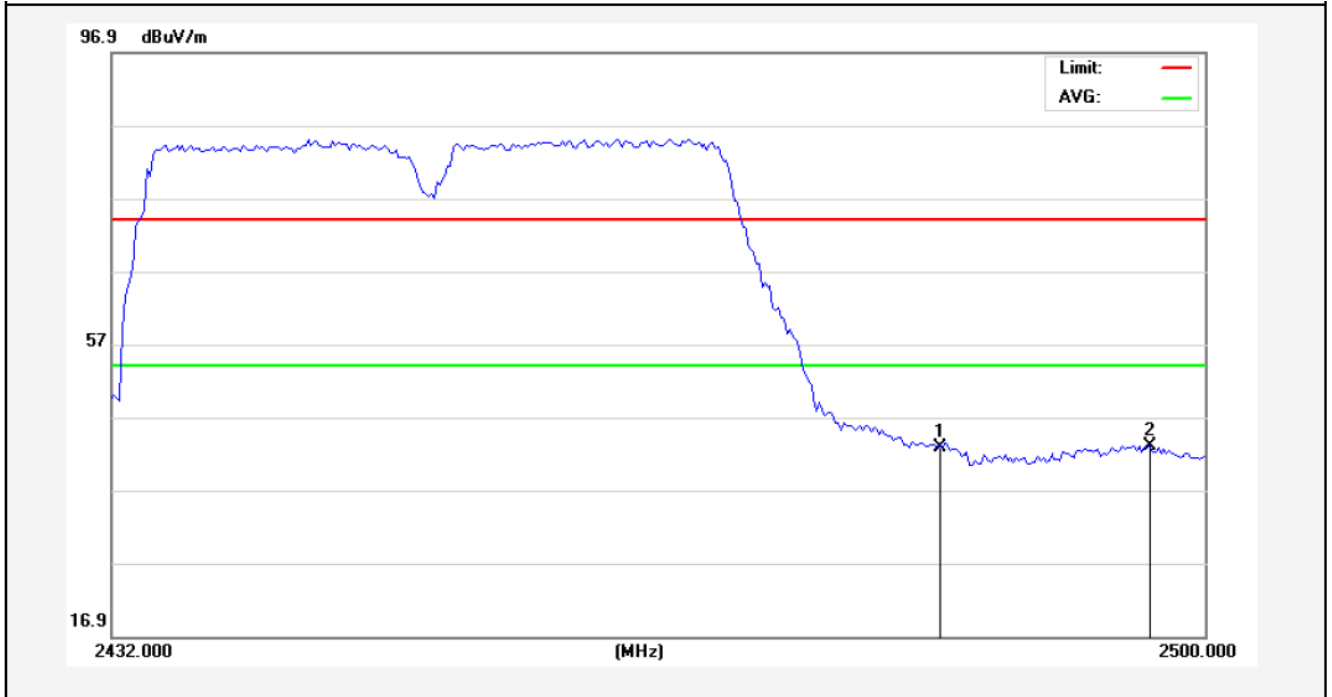

Frequency	CableLoss	AntFactor	PreampFactor	ReadLevel	Level	Limit	Over Limit	Remark
MHz	dB	dB/m	dB	dBμV	dBμV/m	dBμV/m	dB	
2483.500	2.35	30.38	31.47	41.51	42.77	74.00	-31.23	Peak
2496.600	2.40	30.38	31.47	41.68	42.99	74.00	-31.01	Peak

Anbotek

Horizontal-AV:

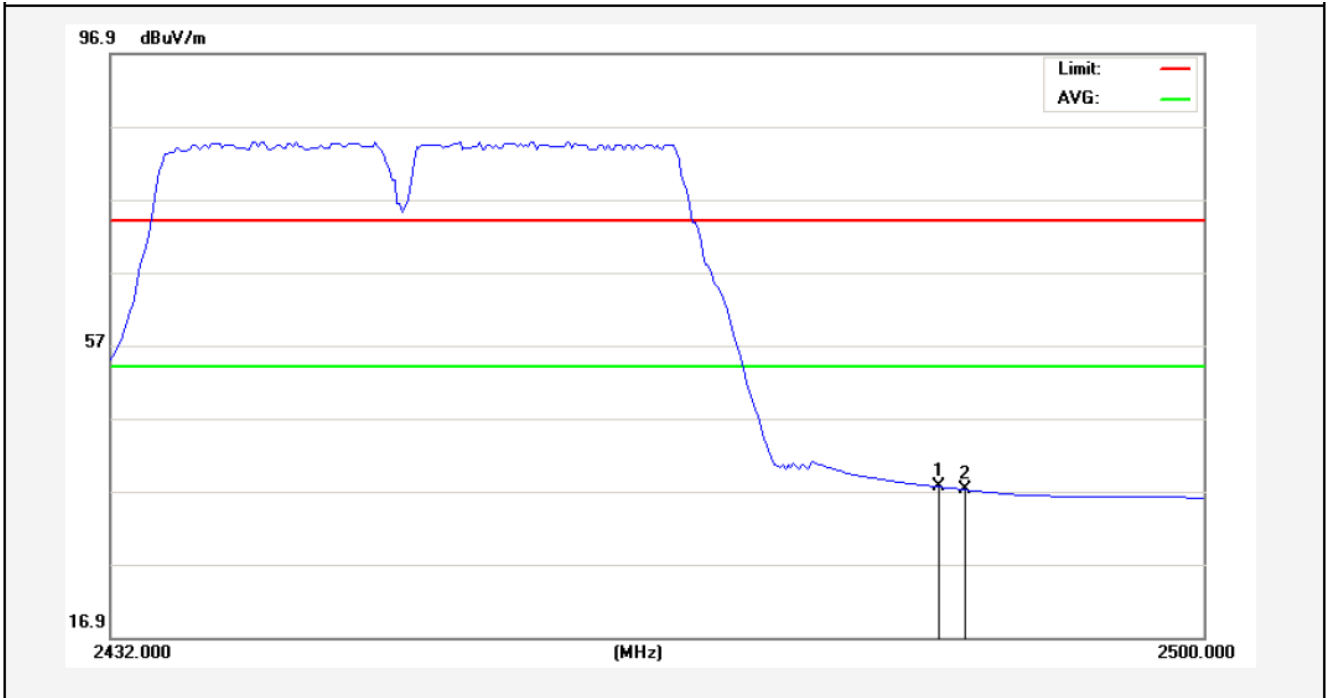

Frequency	CableLoss	AntFactor	Preamplifier	ReadLevel	Level	Limit	Over Limit	Remark
MHz	dB	dB/m	dB	dBμV	dBμV/m	dBμV/m	dB	
2483.500	2.35	30.38	31.47	36.28	37.54	54.00	-16.46	AVG
2485.210	2.35	30.38	31.47	35.88	37.14	54.00	-16.86	AVG

Anbotek

Test Mode: 802.11n (HT40)
2452MHz
Vertical-PEAK:

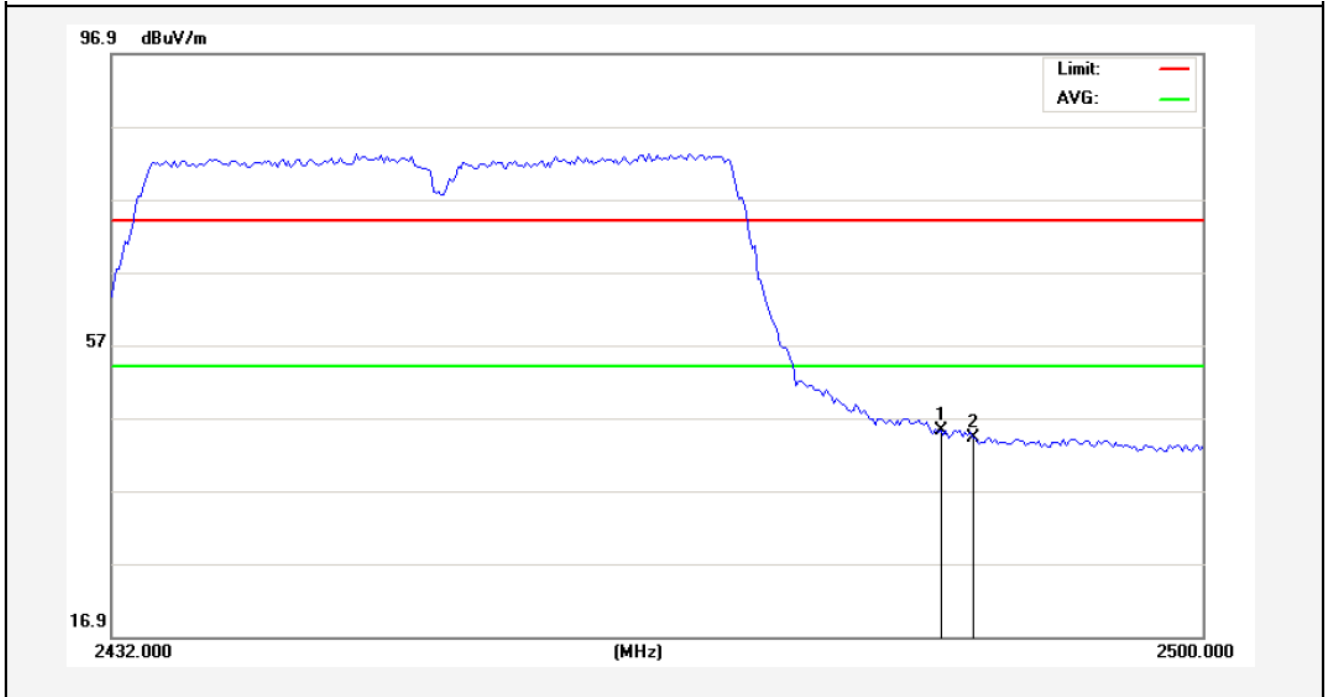

Frequency	CableLoss	AntFactor	PreampFactor	ReadLevel	Level	Limit	Over Limit	Remark
MHz	dB	dB/m	dB	dBμV	dBμV/m	dBμV/m	dB	
2483.500	2.35	30.38	31.47	43.87	45.13	74.00	-28.87	Peak
2485.720	2.35	30.38	31.47	42.94	44.20	74.00	-29.80	Peak

Anbotek

Vertical-AV:

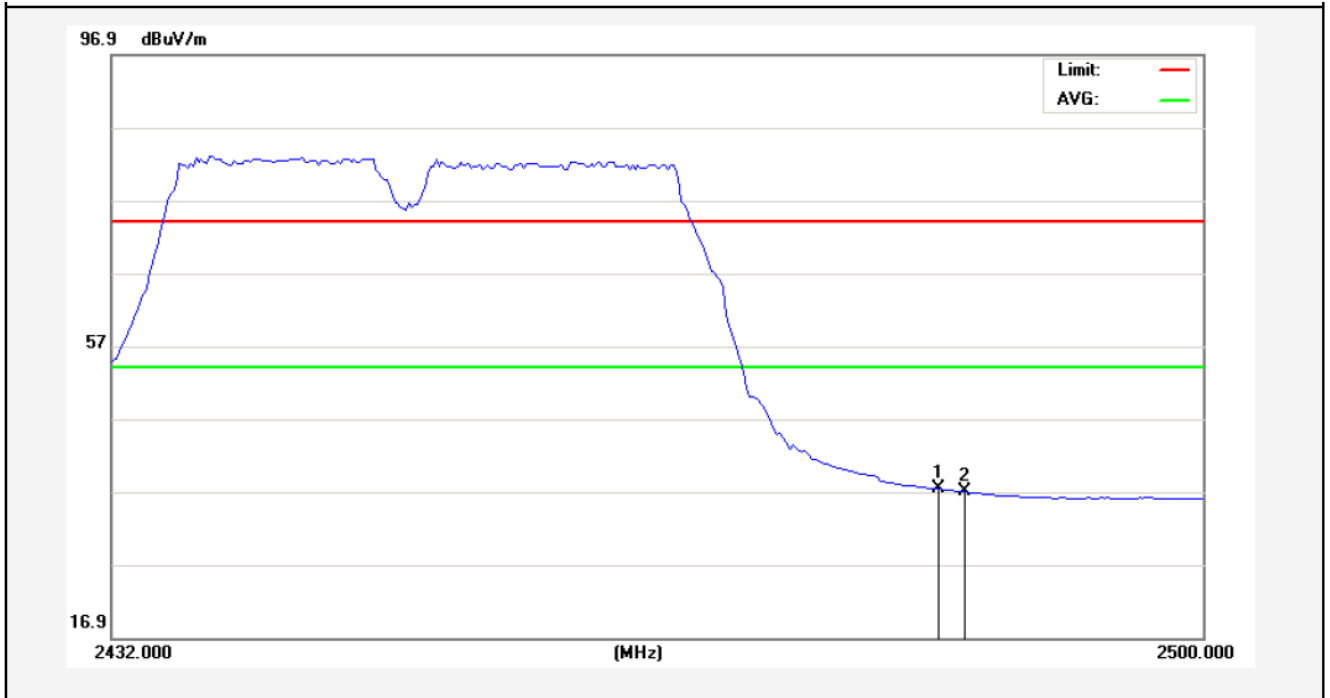

Frequency	CableLoss	AntFactor	Preamplifier	ReadLevel	Level	Limit	Over Limit	Remark
MHz	dB	dB/m	dB	dBμV	dBμV/m	dBμV/m	dB	
2483.500	2.35	30.38	31.47	36.07	37.33	54.00	-16.67	AVG
2485.210	2.35	30.38	31.47	35.70	36.96	54.00	-17.04	AVG

Anbotek

4.5. Peak Power Spectral Density

a. Limit

1. For direct sequence systems, the peak power spectral density conducted from the intentional radiator to the antenna shall not be greater than 8dBm in any 3kHz band during any time interval of continuous transmission.
2. The direct sequence operating of the hybrid system, with the frequency hopping operation turned off, shall comply with the power density requirements of paragraph (d) of this section.

b. Test Procedure

1. Place the EUT on the table and set it in transmitting mode. Remove the antenna from the EUT and then connect a low loss RF cable from the antenna port to the spectrum analyzer.
2. Set the spectrum analyzer as RBW = 3.0kHz, VBW = 10kHz, Span = 1.5xDTS BW
3. Record the max. reading.
4. Repeat the above procedure until the measurements for all frequencies are completed.

c. Test Equipment

Same as the equipment listed in 4.2.

d. Test Setup

See 4.1

e. Test Results

Pass

f. Test Data

Please refer to the following data.

g. Test Plot

See the following pages

Test mode: IEEE 802.11b

Channel	Frequency (MHz)	PPSD (dBm/3KHz)	∑PPSD (dBm/3KHz)	Limit (dBm)	Result
Low	2412	-13.200	-	8.00	Pass
Mid	2437	-13.696	-		Pass
High	2462	-13.184	-		Pass

Test mode: IEEE 802.11g

Channel	Frequency (MHz)	PPSD (dBm)	∑PPSD (dBm)	Limit (dBm)	Result
Low	2412	-16.568	-	8.00	Pass
Mid	2437	-17.373	-		Pass
High	2462	-16.333	-		Pass

Test mode: IEEE 802.11n (HT20)

Channel	Frequency (MHz)	PPSD (dBm/3KHz)	∑PPSD (dBm/3KHz)	Limit (dBm)	Result
Low	2412	-16.173	-	8.00	Pass
Mid	2437	-16.793	-		Pass
High	2462	-16.815	-		Pass

Test mode: IEEE 802.11n (HT40)

Channel	Frequency (MHz)	PPSD (dBm/3KHz)	∑PPSD (dBm/3KHz)	Limit (dBm)	Result
Low	2422	-19.670	-	8.00	Pass
Mid	2437	-20.280	-		Pass
High	2452	-19.904	-		Pass

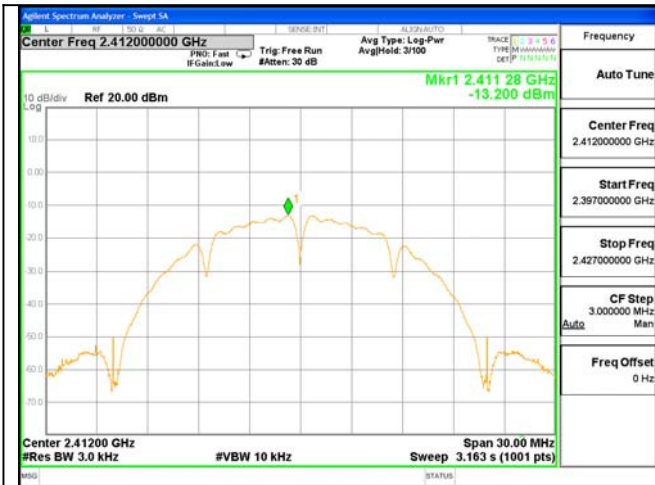

Test Mode: 802.11b---Low



Test Mode: 802.11b---Mid

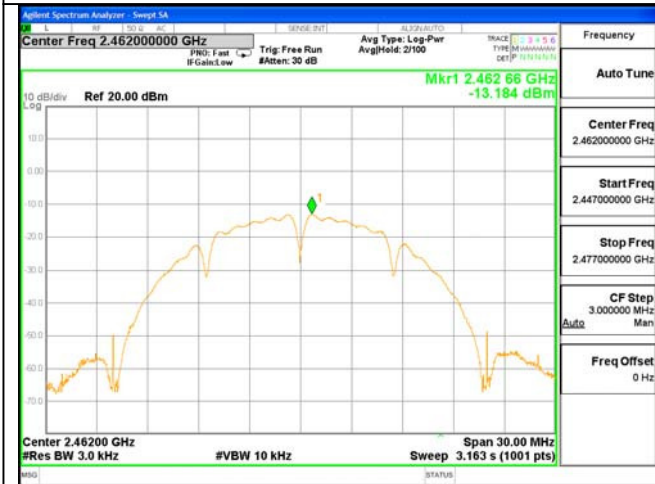

Test Mode: 802.11b---High

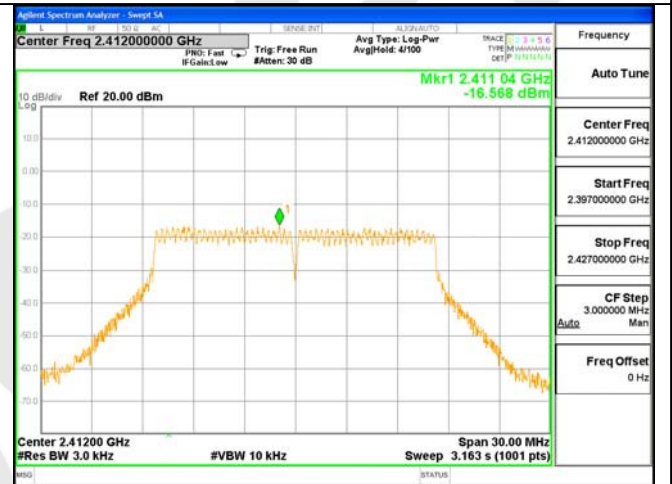

Test Mode: 802.11g---Low

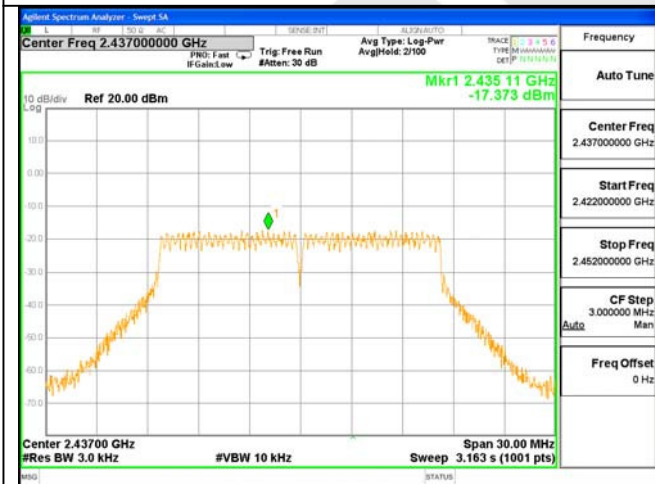

Test Mode: 802.11g---Mid

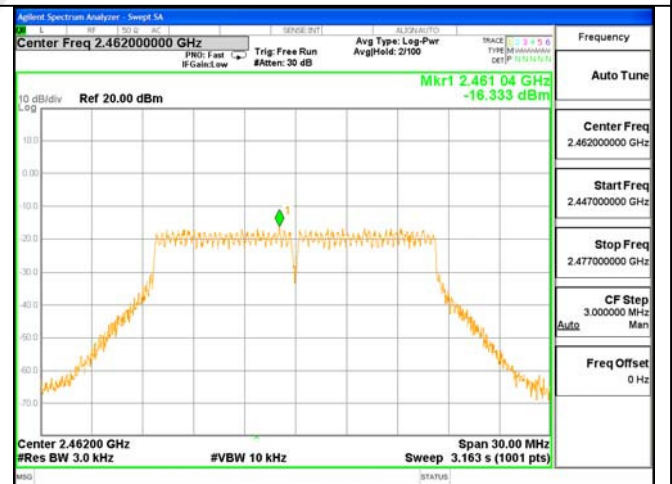

Test Mode: 802.11g---High

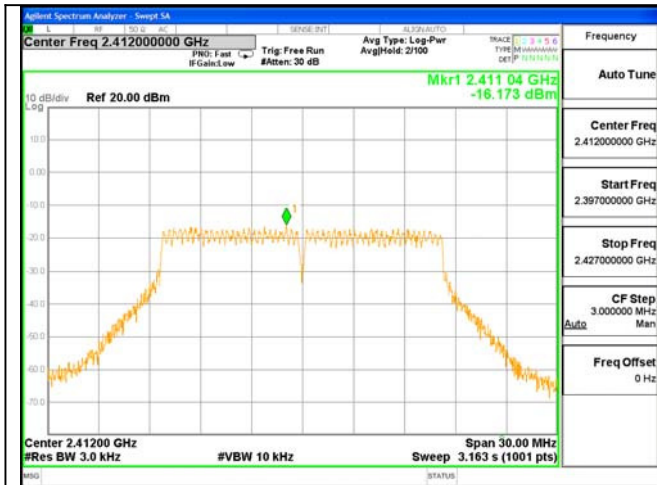

Test Mode: 802.11n20---Low

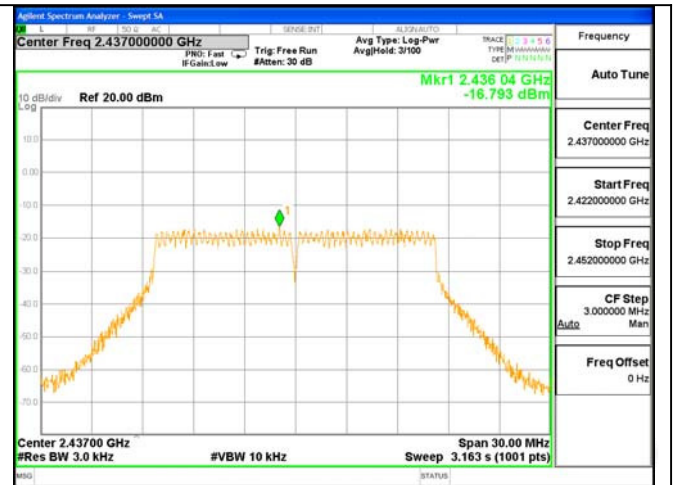

Test Mode: 802.11n20---Mid

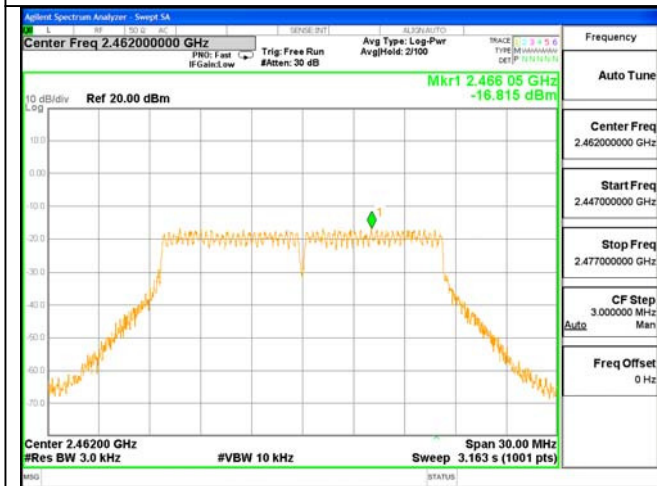

Test Mode: 802.11n20---High

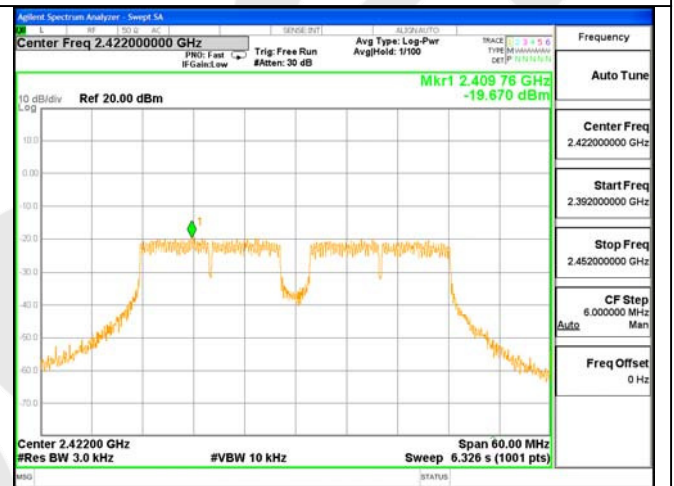

Test Mode: 802.11n40---Low

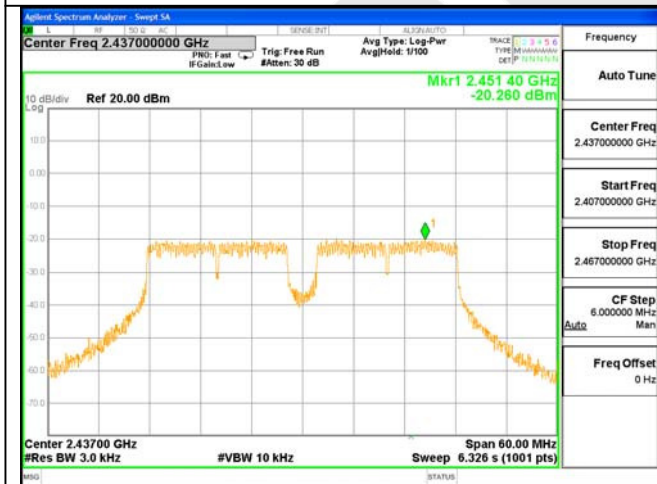

Test Mode: 802.11n40---Mid

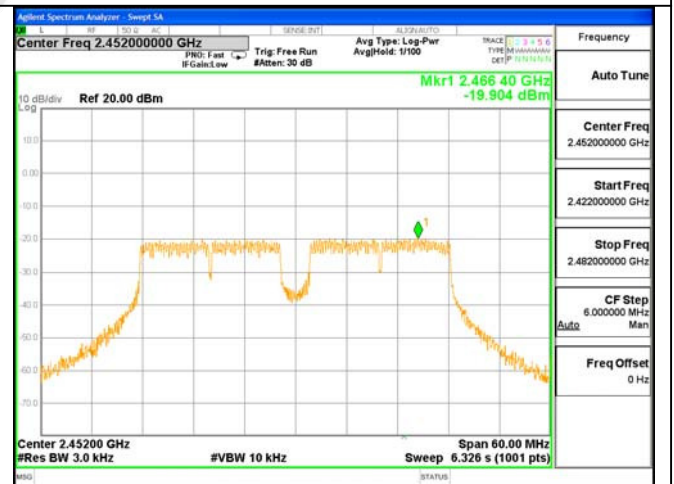

Test Mode: 802.11n40---High

4.6. Radiated Emissions

4.6.1.1. Test Limits (< 30 MHz)

Frequency (MHz)	Field Strength (microvolts/meter)	Measurement Distance (meter)
0.009-0.490	2400/F(kHz)	300
0.490-1.705	24000/F(kHz)	30
1.705-30.0	30	30

4.6.1.2. Test Limits (≥ 30 MHz)

FIELD STRENGTH of Fundamental: @3M	FIELD STRENGTH of Harmonics	S15.209	
902-928 MHz		30 - 88 MHz	40 dBuV/m
2.4-2.4835 GHz		88 - 216 MHz	43.5
94 dBμV/m @3m	54 dBμV/m @3m	216 - 960 MHz	46
		ABOVE 960 MHz	54dBuV/m

In any 100 kHz bandwidth outside the frequency band in which the spread spectrum or digitally modulated intentional radiator is operating, the radio frequency power that is produced by the intentional radiator shall be at least 20 dB below that in the 100 kHz bandwidth within the band that contains the highest level of the desired power, based on either an RF conducted or a radiated measurement. Attenuation below the general limits specified in Section 15.209(a) is not required. In addition, radiated emissions which fall in the restricted bands, as defined in Section 15.205(a), must also comply with the radiated emission limits specified in Section 15.209(a) (see Section 15.205(c)).

Test Equipment

Item	Equipment	Manufacturer	Model No.	Serial No.	Last Cal.	Cal. Interval
1.	Spectrum Analysis	Agilent	E4407B	US39390582	Apr. 16, 2016	1 Year
2.	Preamplifier	Instruments corporation	EMC011830	980100	Apr. 16, 2016	1 Year
3.	EMI Test Receiver	Rohde & Schwarz	ESPI	101604	Apr. 16, 2016	1 Year
4.	Double Ridged Horn Antenna	Instruments corporation	GTH-0118	351600	Apr. 19, 2016	1 Year
5.	Bilog Broadband Antenna	Schwarzbeck	VULB9163	VULB 9163-289	Apr. 19, 2016	1 Year
6.	Pre-amplifier	SONOMA	310N	186860	Apr. 16, 2016	1 Year
7.	EMI Test Software EZ-EMC	SHURPLE	N/A	N/A	N/A	N/A
8.	Power Sensor	DAER	RPR3006W	15100041SN046	Jun 30, 2016	1 Year
9.	MXA Spectrum Analysis	Agilent	N9020A	MY51170037	Jun 30, 2016	1 Year
10.	MXG RF Vector Signal Generator	Agilent	N5182A	MY48180656	Jun 30, 2016	1 Year
11.	Signal Generator	Agilent	E4421B	MY41000743	Jun 30, 2016	1 Year
12.	DC Power supply	IV	IV-8080	YQSB0096	Jun 30, 2016	1 Year
13.	TEMP&HUMI PROGRAMMABLE CHAMBER	Bell Group	BE-THK-15 0M8	SE-0137	Mar. 16, 2016	1 Year

4.6.2. Test Configuration:

4.6.2.1. 9k to 30MHz emissions:

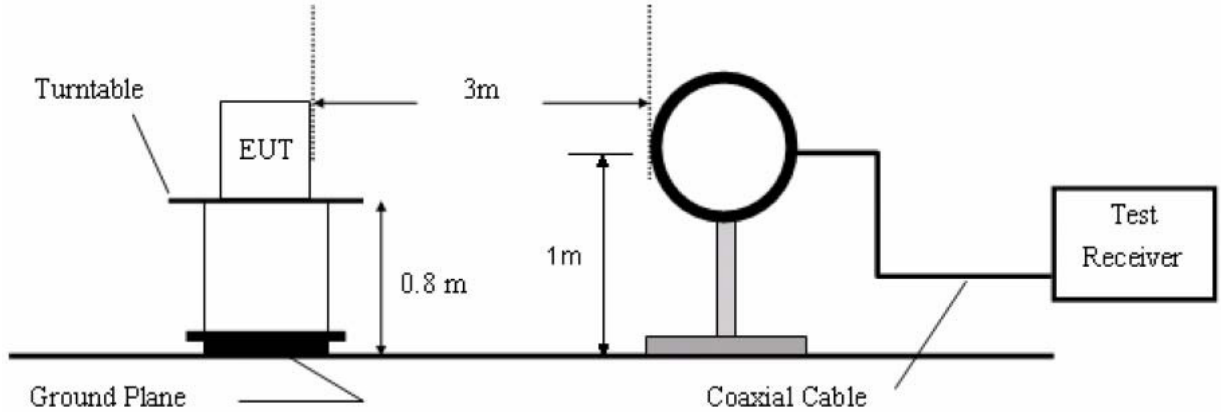

4.6.2.2. 30M to 1G emissions:

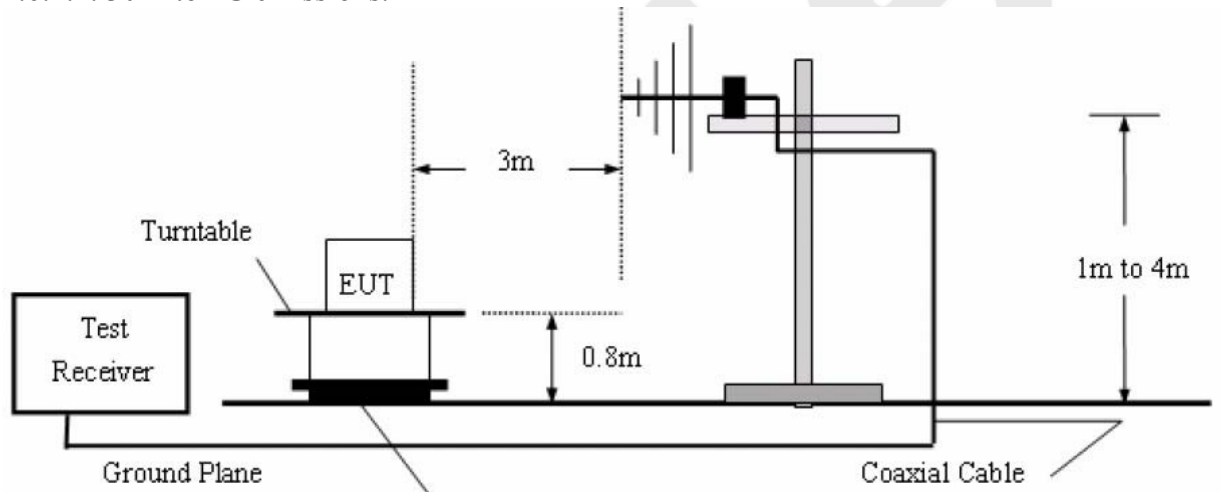

4.6.2.3. 1G to 40G emissions:

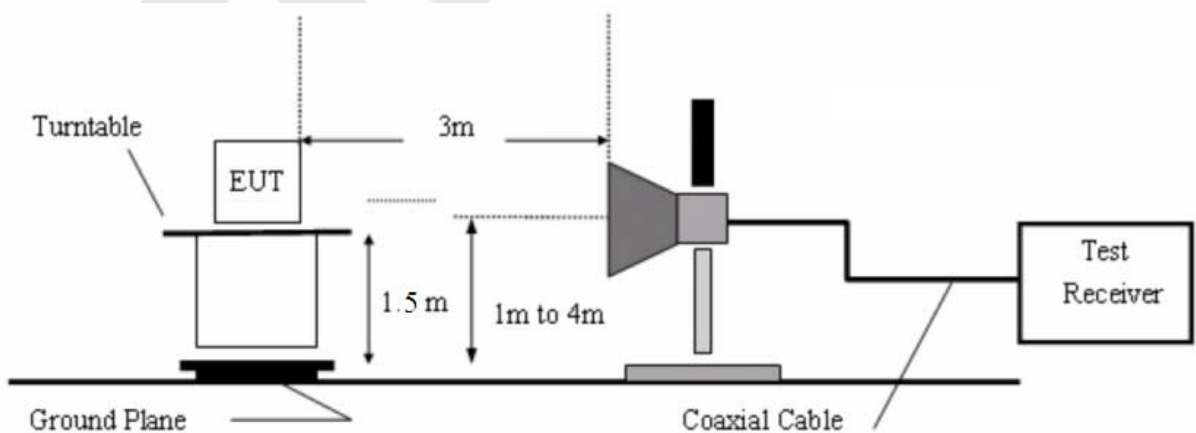

4.6.3. Test Procedure

For below 1GHz: The EUT is placed on a turntable, which is 0.8m above the ground plane.
For above 1GHz: The EUT is placed on a turntable, which is 1.5m above the ground plane.
The turn table can rotate 360 degrees to determine the position of the maximum emission level.
The EUT is set 3 meters away from the receiving antenna which is mounted on a antenna tower.
The antenna can be moved up and down from 1 to 4 meters to find out the maximum emission level. Both horizontal and vertical polarization of the antenna are set on test.

Measurements are made on 9KHz to 30MHz and 30MHz to 26GHz range with the transmitter set to the lowest, middle, and highest channels.

All readings from 30MHz to 1GHz are quasi-peak values with a resolution bandwidth of 120kHz. All reading are above 1GHz, peak & average values with a resolution bandwidth of 1MHz.

The EUT is tested in 9*6*6 Chamber. The device is evaluated in xyz orientation.

The test results are listed in Section 4.6.4.

4.6.4. Test Results

The EUT was tested on (HDMI+WAN Mode, HDMI+USB Mode, HDMI+TF Mode, HDMI+WiFi Mode, AV+WAN Mode, AV+USB Mode, AV+TF Mode, AV+WiFi Mode) modes, only the worst data of (Internet Mode) is attached in the following pages.
Only the worst case (x orientation).

The test results of above 18000MHz are attenuated more than 20dB below the permissible limits, so the results don't record in the report.

Job No.:	0116102511	Polarization:	Horizontal
Standard:	(RE)FCC PART15 C_3m	Power Source:	AC 120V, 60Hz for adapter
Test item:	Radiation Test	Temp.(C)/Hum.(%RH):	24.6(C)/53% RH
Test Mode:	HDMI+USB Mode	Distance:	3m

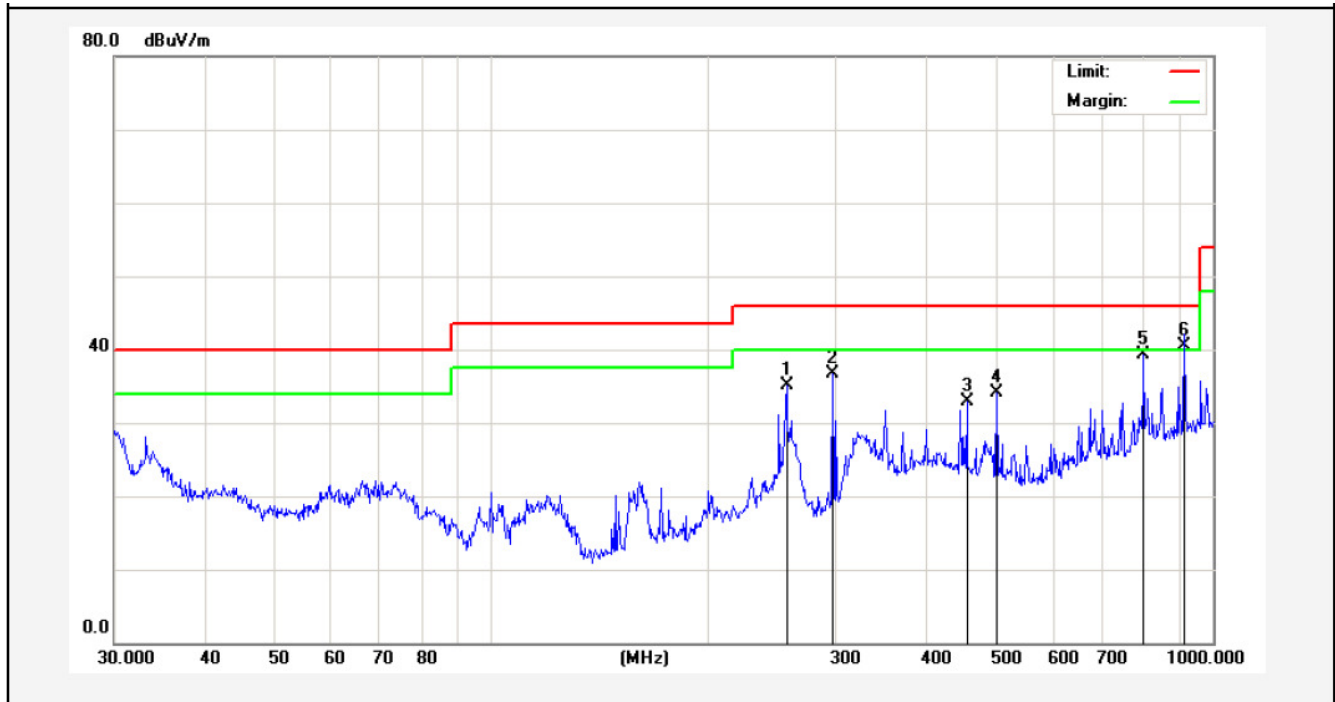

No.	Freq. (MHz)	Reading (dBuV/m)	Factor (dB/m)	Result (dBuV/m)	Limit (dBuV/)	Over Limit (dB)	Detector	Height (cm)	degree (deg)	Remark
1	256.5211	53.85	-18.84	35.01	46.00	-10.99	peak			
2	297.2241	54.49	-17.76	36.73	46.00	-9.27	peak			
3	455.9058	44.97	-12.12	32.85	46.00	-13.15	peak			
4	501.1790	45.15	-10.96	34.19	46.00	-11.81	peak			
5	801.7863	45.75	-6.54	39.21	46.00	-6.79	peak			
6	912.8620	44.98	-4.56	40.42	46.00	-5.58	QP	300	0	

Job No.:	0116102511	Polarization:	Vertical
Standard:	(RE)FCC PART15 C_3m	Power Source:	AC 120V, 60Hz for adapter
Test item:	Radiation Test	Temp.(C)/Hum.(%RH):	24.6(C)/53%RH
Test Mode:	HDMI+USB Mode	Distance:	3m

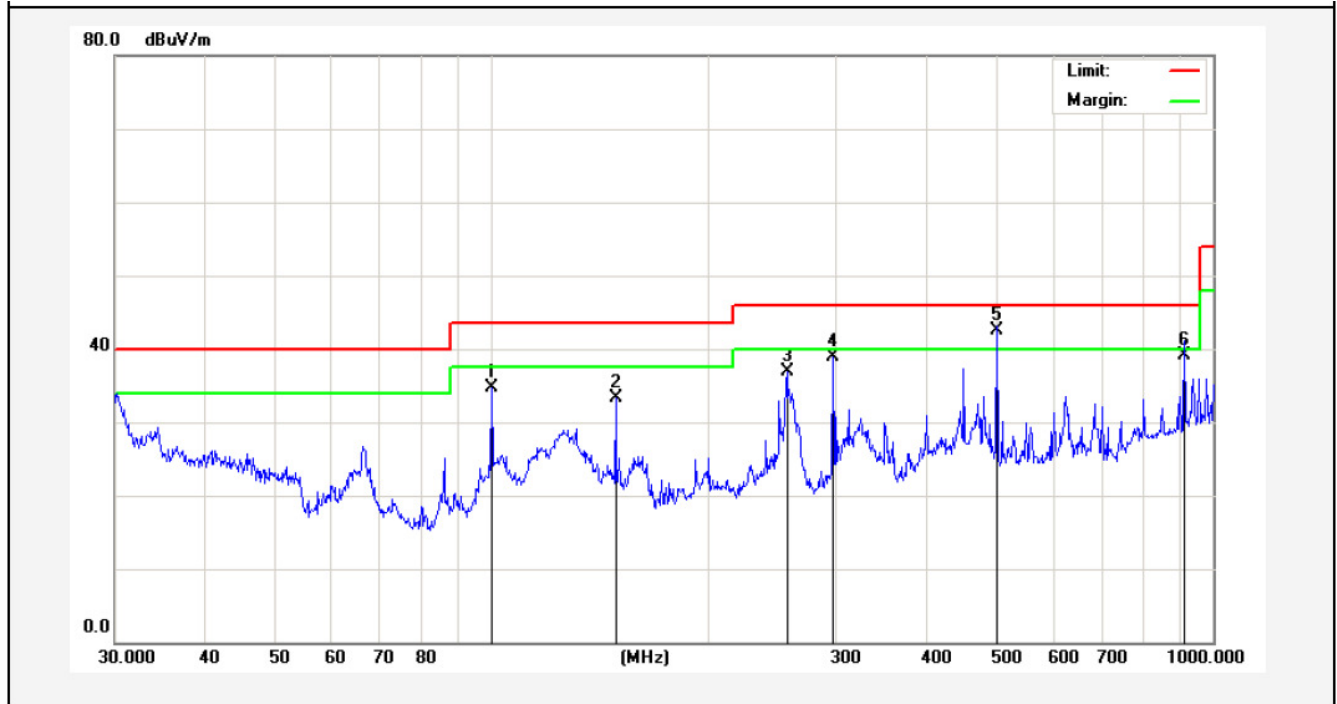

No.	Freq. (MHz)	Reading (dBuV/m)	Factor (dB/m)	Result (dBuV/m)	Limit (dBuV/)	Over Limit (dB)	Detector	Height (cm)	degree (deg)	Remark
1	99.8777	50.46	-15.78	34.68	43.50	-8.82	peak			
2	148.4410	51.68	-18.36	33.32	43.50	-10.18	peak			
3	256.5210	50.91	-14.00	36.91	46.00	-9.09	peak			
4	297.2241	53.57	-14.76	38.81	46.00	-7.19	peak			
5	501.1790	53.40	-10.94	42.46	46.00	-3.54	QP	100	0	
6	912.8618	42.59	-3.56	39.03	46.00	-6.97	QP	100	360	

Job No.:	0116102511	Polarization:	Horizontal
Standard:	(RE)FCC PART15 C _3m	Power Source:	AC 120V, 60Hz for adapter
Test item:	Radiation Test	Temp.(C)/Hum.(%RH):	24.6(C)/53% RH
Note:	802.11b(2412MHz)	Distance:	3m

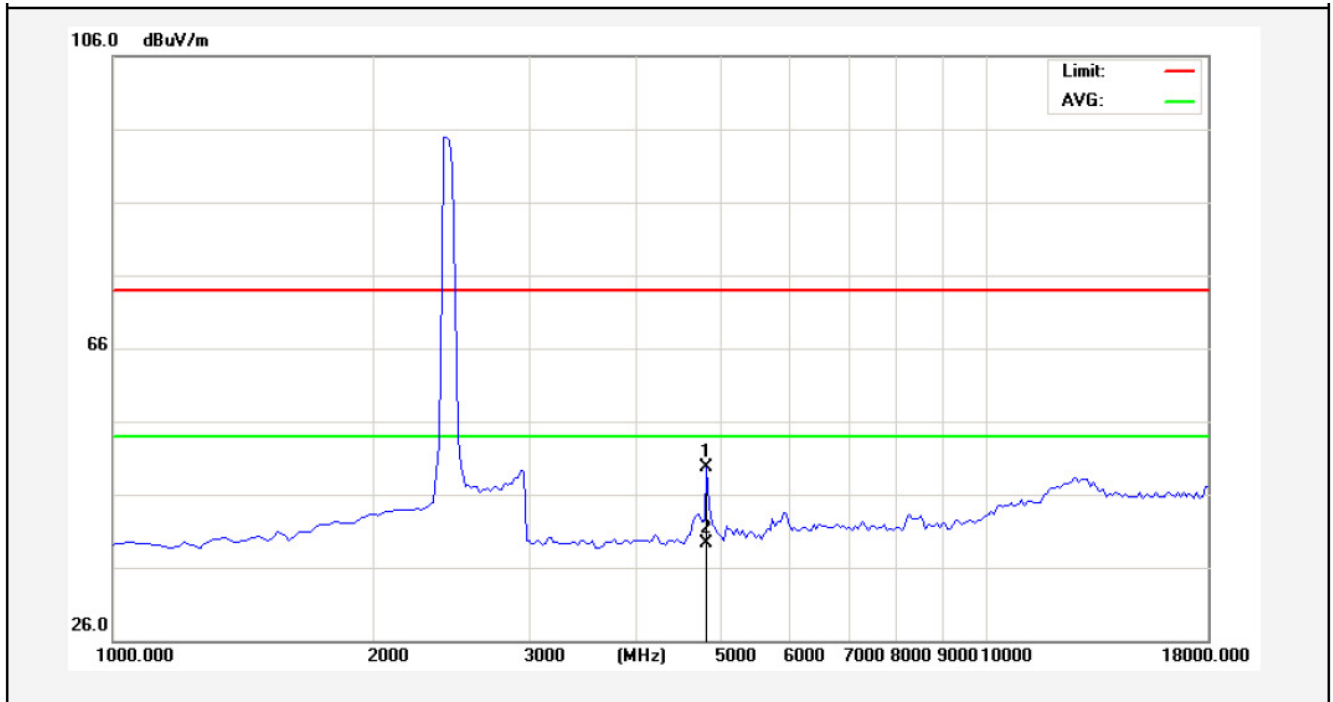

No.	Freq. (MHz)	Reading (dBuV/m)	Factor (dB/m)	Result (dBuV/m)	Limit (dBuV/)	Over Limit (dB)	Detector	Height (cm)	degree (deg)	Remark
1	4825.000	46.32	3.34	49.66	74.00	-24.34	peak			
2	4825.000	36.05	3.34	39.39	54.00	-14.61	AVG			

Job No.:	0116102511	Polarization:	Vertical
Standard:	(RE)FCC PART15 C _3m	Power Source:	AC 120V, 60Hz for adapter
Test item:	Radiation Test	Temp.(C)/Hum.(%RH):	24.6(C)/53% RH
Note:	802.11b(2412MHz)	Distance:	3m

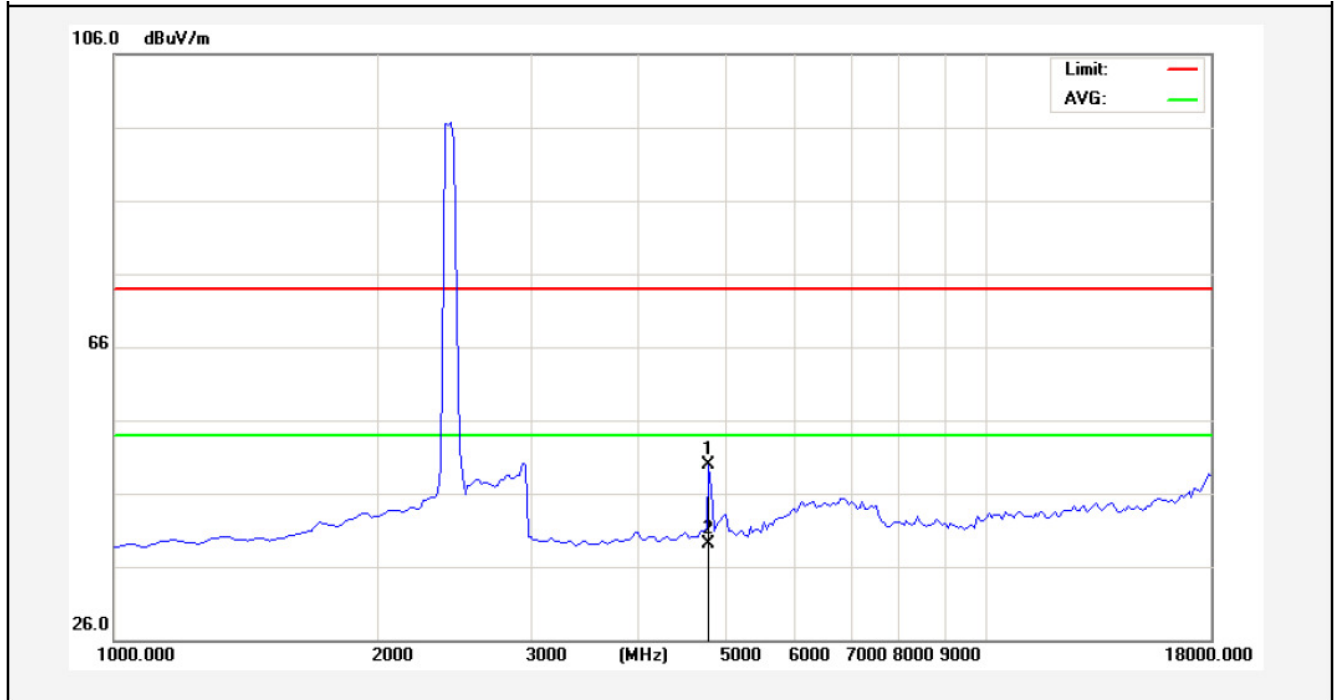

No.	Freq. (MHz)	Reading (dBuV/m)	Factor (dB/m)	Result (dBuV/m)	Limit (dBuV/)	Over Limit (dB)	Detector	Height (cm)	degree (deg)	Remark
1	4825.000	46.62	3.34	49.96	74.00	-24.04	peak			
2	4825.000	35.77	3.34	39.11	54.00	-14.89	AVG			

AEM

Job No.:	0116102511	Polarization:	Horizontal
Standard:	(RE)FCC PART15 C _3m	Power Source:	AC 120V, 60Hz for adapter
Test item:	Radiation Test	Temp.(C)/Hum.(%RH):	24.6(C)/53% RH
Note:	802.11b(2437MHz)	Distance:	3m

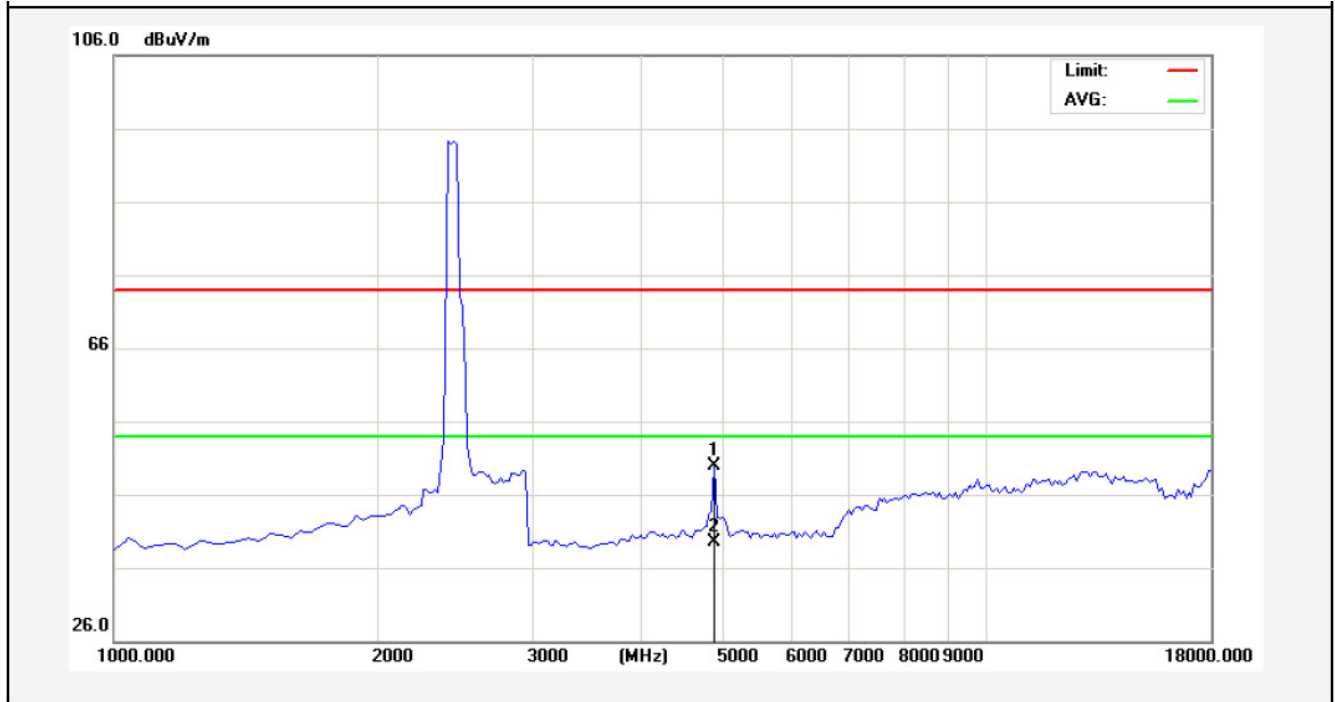

No.	Freq. (MHz)	Reading (dBuV/m)	Factor (dB/m)	Result (dBuV/m)	Limit (dBuV/)	Over Limit (dB)	Detector	Height (cm)	degree (deg)	Remark
1	4867.500	46.56	3.41	49.97	74.00	-24.03	peak			
2	4867.500	36.02	3.41	39.43	54.00	-14.57	AVG			

Job No.:	0116102511	Polarization:	Vertical
Standard:	(RE)FCC PART15 C_3m	Power Source:	AC 120V, 60Hz for adapter
Test item:	Radiation Test	Temp.(C)/Hum.(%RH):	24.6(C)/53% RH
Note:	802.11b(2437MHz)	Distance:	3m

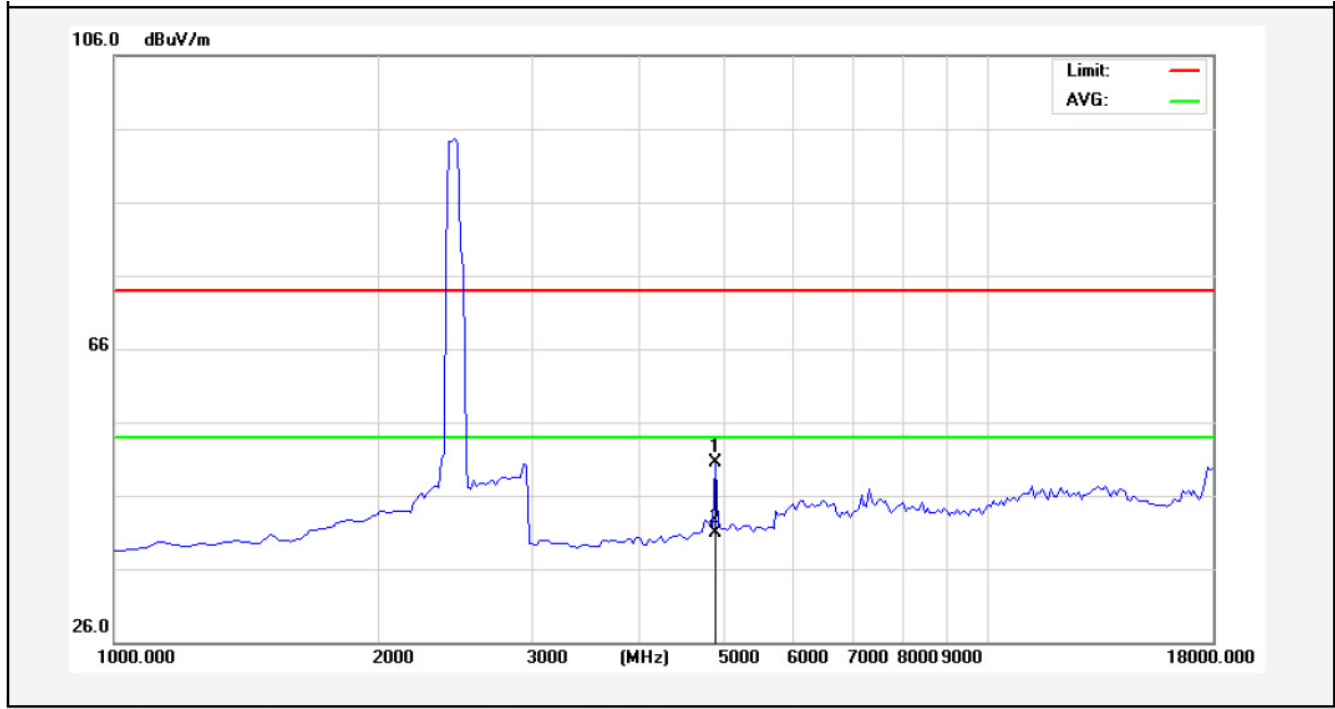

No.	Freq. (MHz)	Reading (dBuV/m)	Factor (dB/m)	Result (dBuV/m)	Limit (dBuV/)	Over Limit (dB)	Detector	Height (cm)	degree (deg)	Remark
1	4867.500	47.06	3.41	50.47	74.00	-23.53	peak			
2	4867.500	37.53	3.41	40.94	54.00	-13.06	AVG			



Job No.:	011610251I	Polarization:	Horizontal
Standard:	(RE)FCC PART15 C_3m	Power Source:	AC 120V, 60Hz for adapter
Test item:	Radiation Test	Temp.(C)/Hum.(% RH):	24.6(C)/53% RH
Note:	802.11b(2462MHz)	Distance:	3m

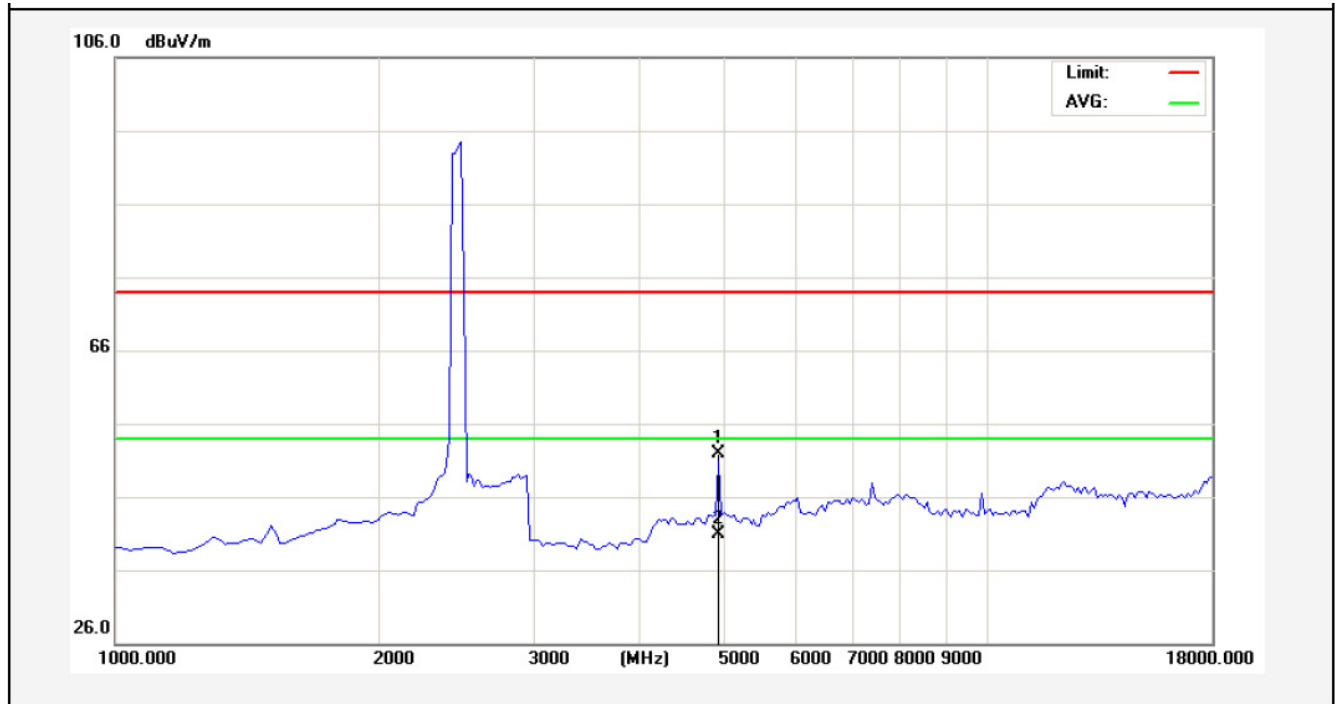

No.	Freq. (MHz)	Reading (dBuV/m)	Factor (dB/m)	Result (dBuV/m)	Limit (dBuV/)	Over Limit (dB)	Detector	Height (cm)	degree (deg)	Remark
1	4910.000	48.38	3.49	51.87	74.00	-22.13	peak			
2	4910.000	37.51	3.49	41.00	54.00	-13.00	AVG			

Job No.:	0116102511	Polarization:	Vertical
Standard:	(RE)FCC PART15 C_3m	Power Source:	AC 120V, 60Hz for adapter
Test item:	Radiation Test	Temp.(C)/Hum.(%RH):	24.6(C)/53%RH
Note:	802.11b(2462MHz)	Distance:	3m

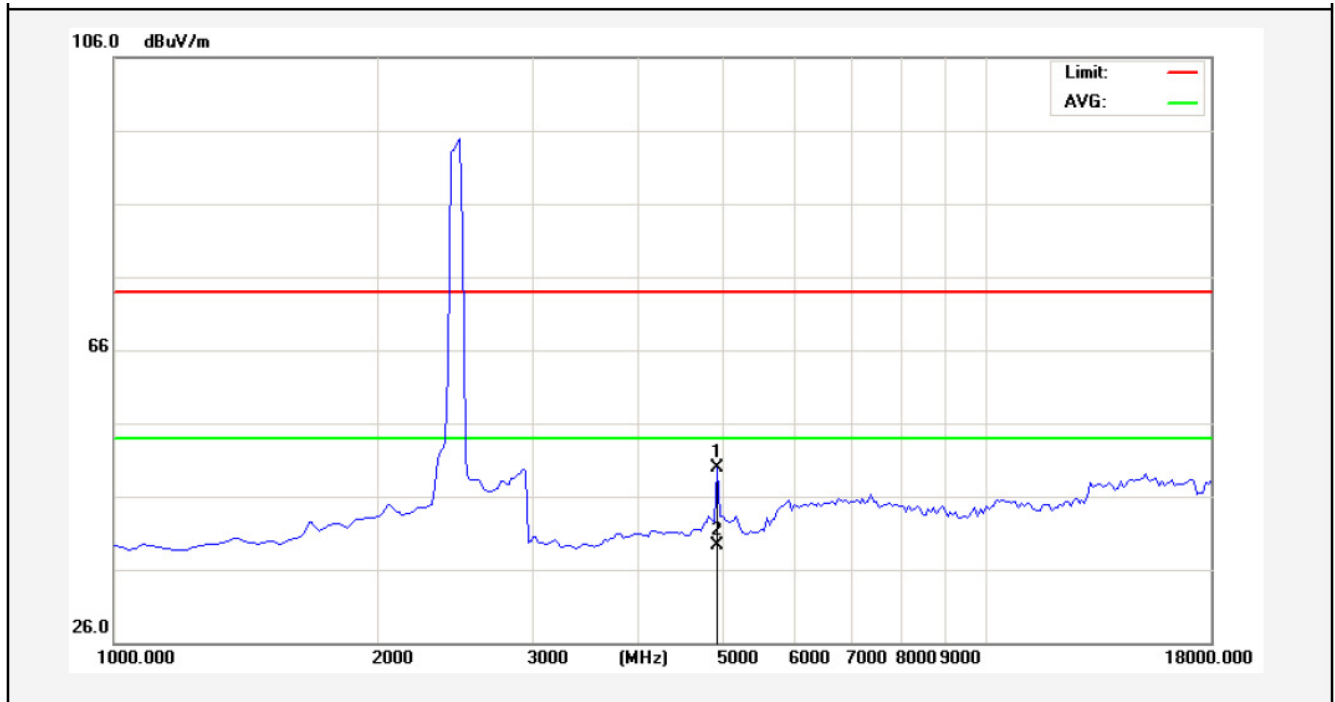

No.	Freq. (MHz)	Reading (dBuV/m)	Factor (dB/m)	Result (dBuV/m)	Limit (dBuV/)	Over Limit (dB)	Detector	Height (cm)	degree (deg)	Remark
1	4910.000	46.43	3.49	49.92	74.00	-24.08	peak			
2	4910.000	35.73	3.49	39.22	54.00	-14.78	AVG			



5. ANTENNA APPLICATION

5.1. Antenna requirement

The EUT'S antenna is met the requirement of FCC part 15C section 15.203.

An intentional radiator shall be designed to ensure that no antenna other than that furnished by the responsible party shall be used with the device. The use of a permanently attached antenna or of an antenna that uses a unique coupling to the intentional radiator shall be considered sufficient to comply with the provisions of this section. The manufacturer may design the unit so that a broken antenna can be replaced by the user, but the use of a standard antenna jack or electrical connector is prohibited. This requirement does not apply to carrier current devices or to devices operated under the provisions of §15.211, §15.213, §15.217, §15.219, or §15.221. Further, this requirement does not apply to intentional radiators that must be professionally installed, such as perimeter protection systems and some field disturbance sensors, or to other intentional radiators which, in accordance with §15.31(d), must be measured at the installation site. However, the installer shall be responsible for ensuring that the proper antenna is employed so that the limits in this part are not exceeded.

5.2. Result

The EUT's antenna used a external antenna which is permanently attached, The antenna's gain is 1dBi and meets the requirement.

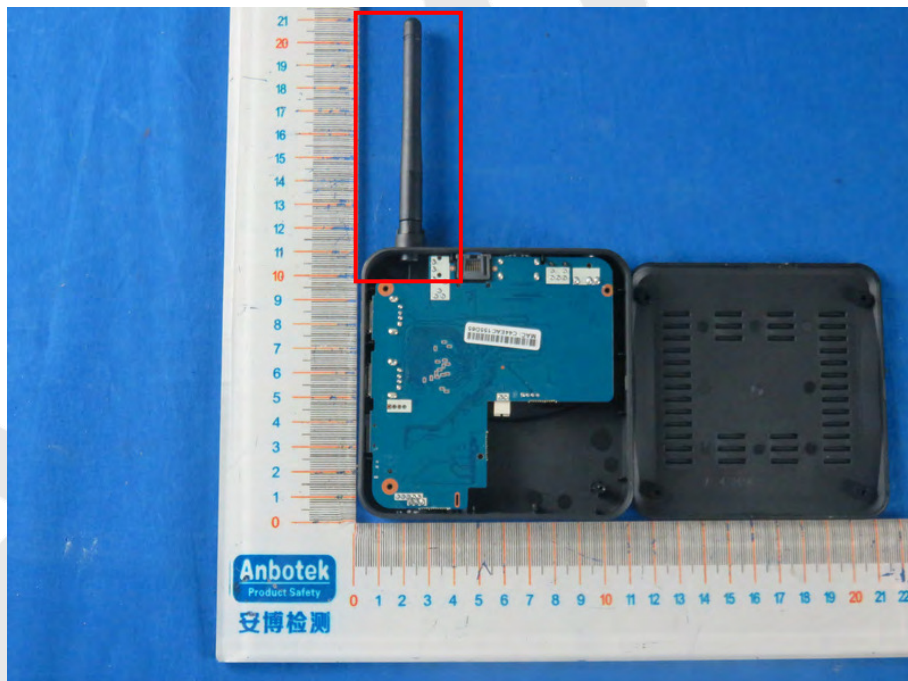

6. PHOTOGRAPH

6.1. Photo of Conducted Emission Measurement



6.2. Photo of Radiation Emission Test

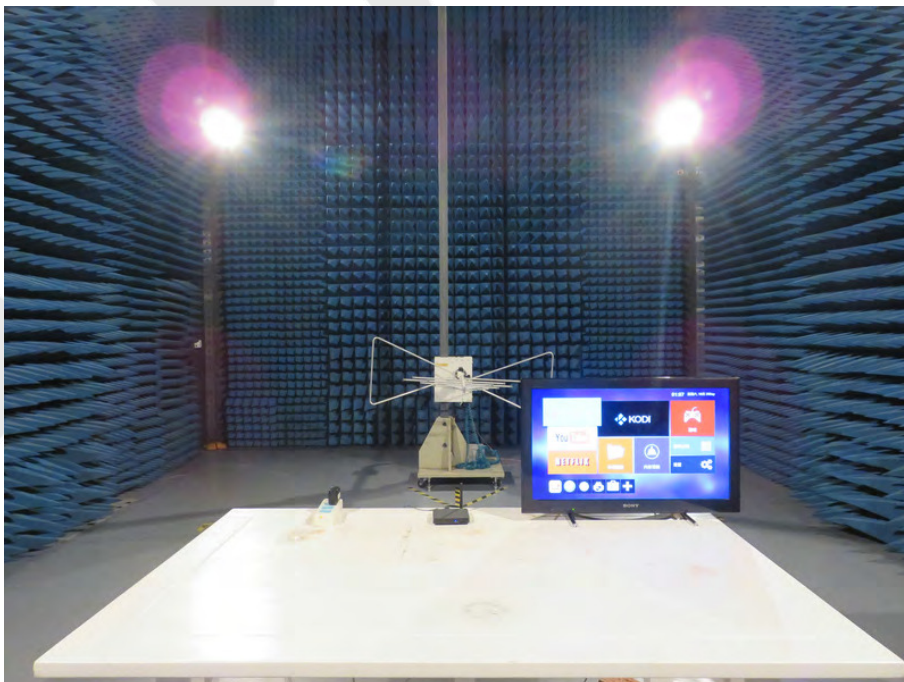

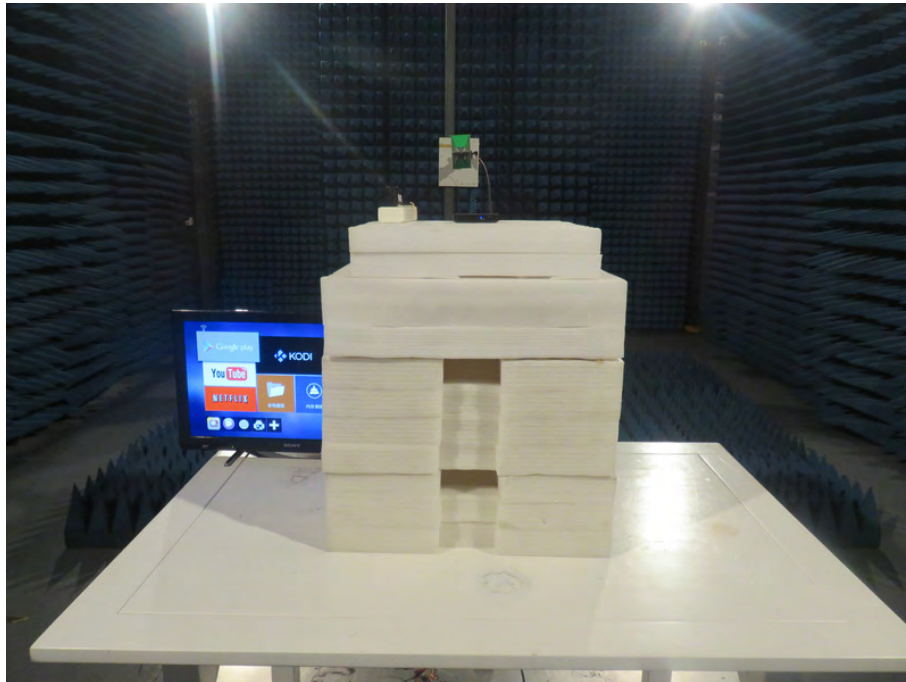

APPENDIX I (EXTERNAL PHOTOS)

1. Figure
The EUT-Overall View



2. Figure
The EUT-Top View



3. Figure
The EUT-Bottom View



4. Figure
The EUT-Front View



5. Figure
The EUT-Back View

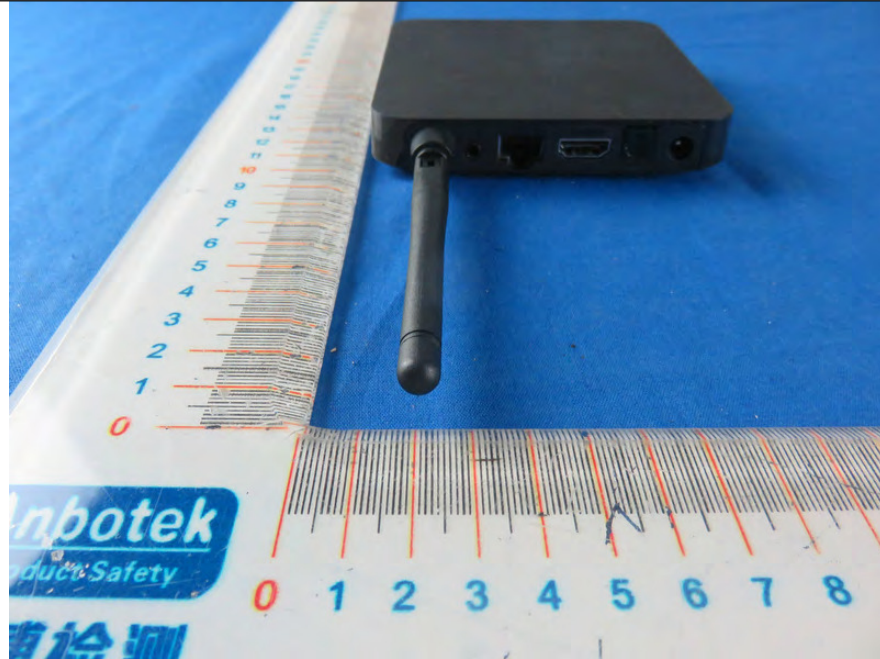

6. Figure
The EUT-Right View



7. Figure
The EUT-Left View

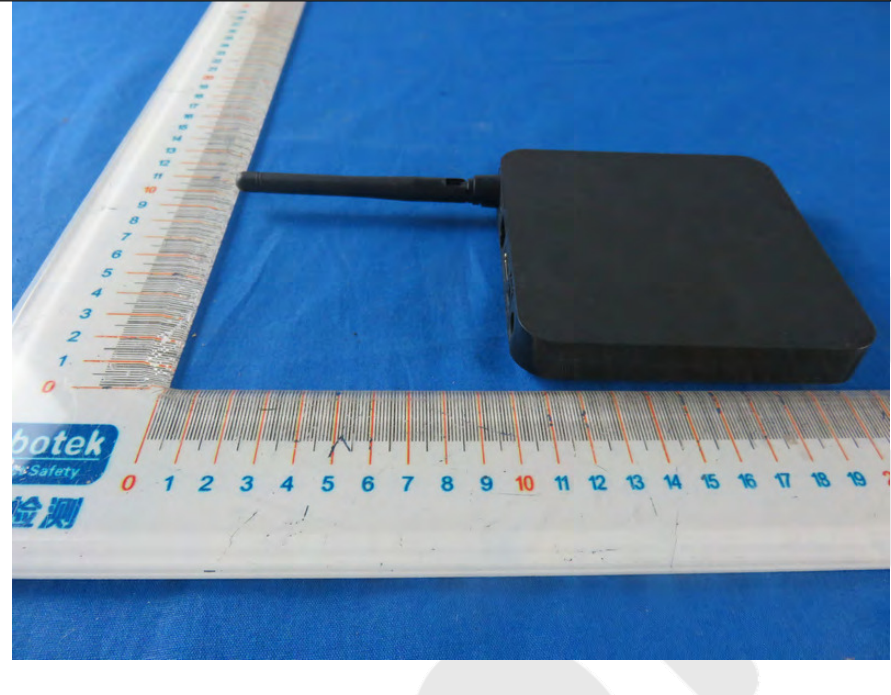

Anbotek

APPENDIX II (INTERNAL PHOTOS)

1. Figure
The EUT-Inside View

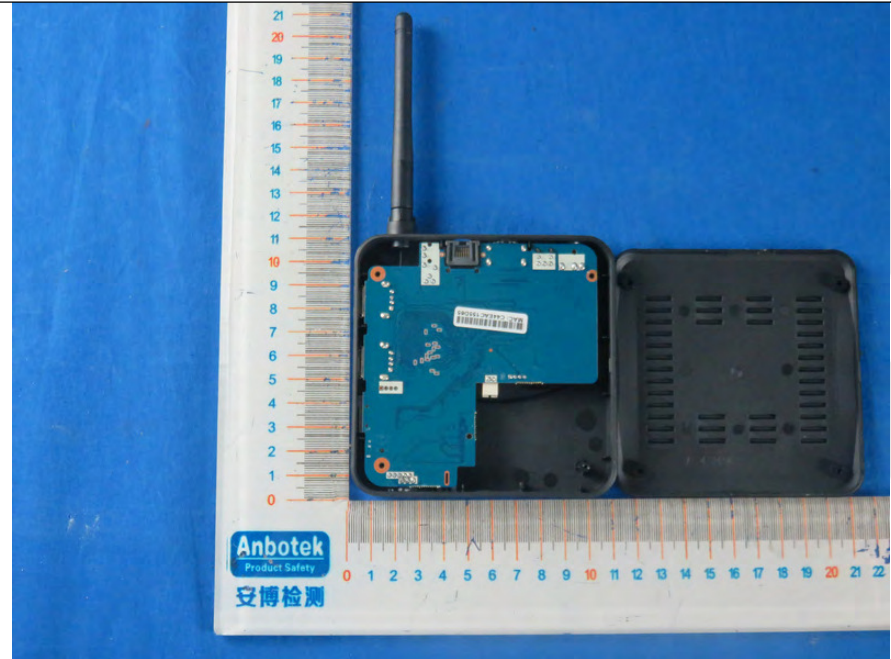

2. Figure
PCB of the EUT-Front View

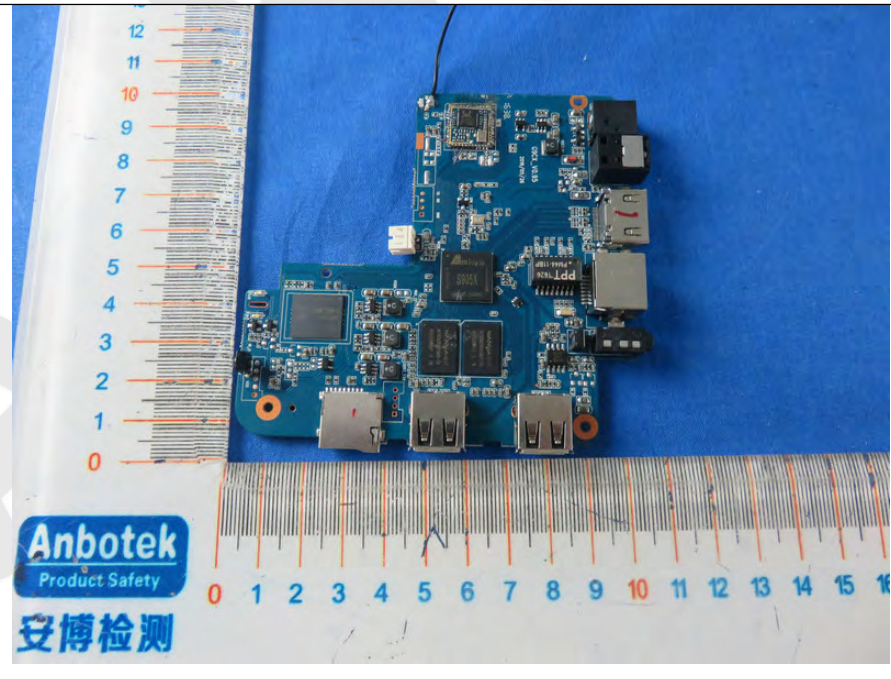

3. Figure
PCB of the EUT-Front View

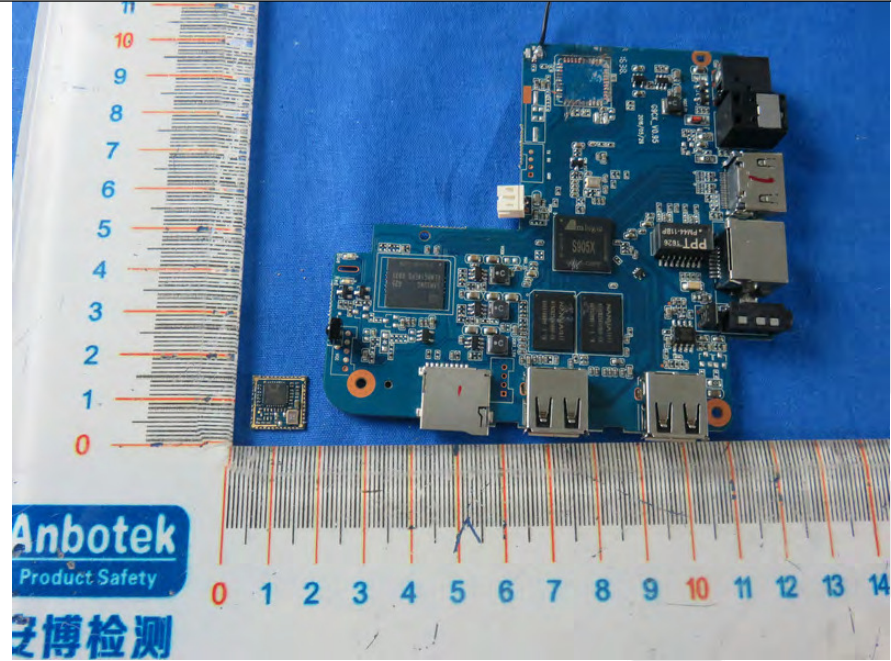

4. Figure
PCB of the EUT-Back View

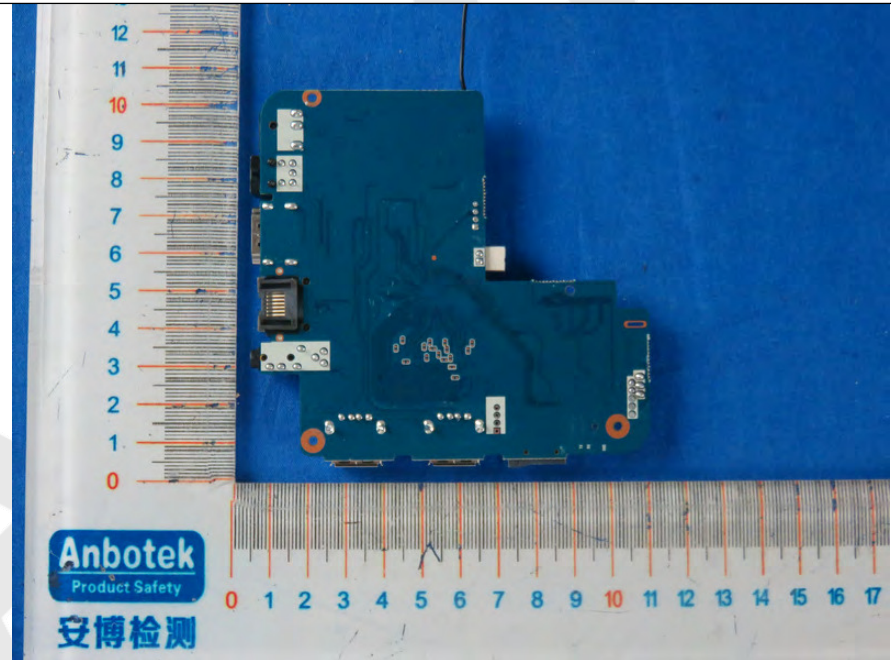

5. Figure
PCB of the EUT-Front View

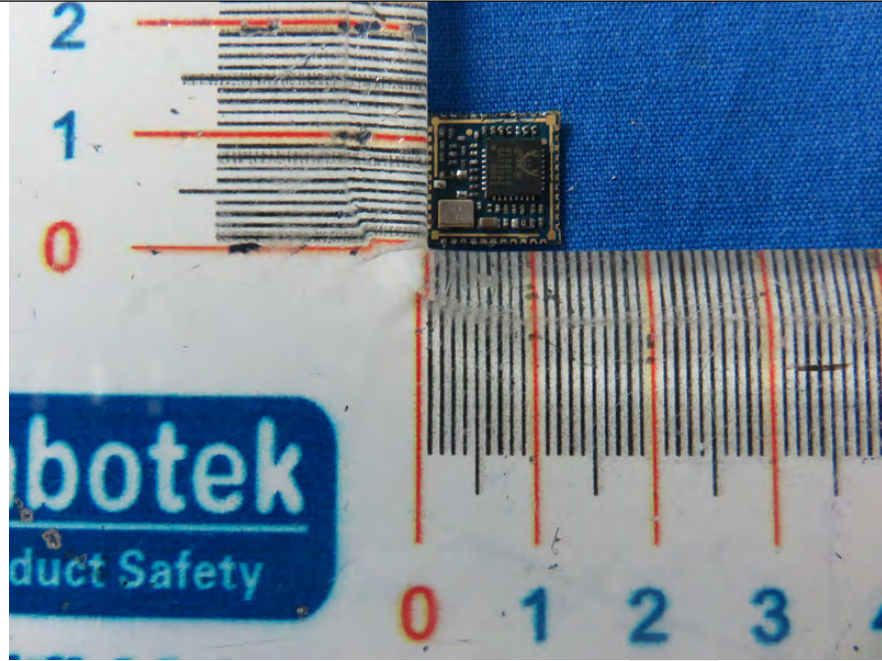

6. Figure
PCB of the EUT-Back View

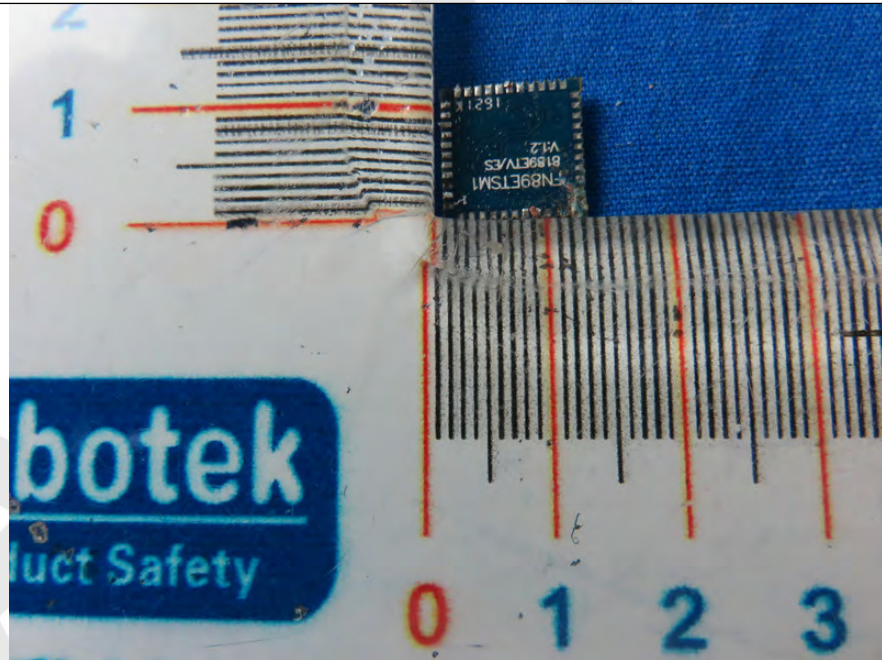

7. Figure
PCB of the EUT-Front View

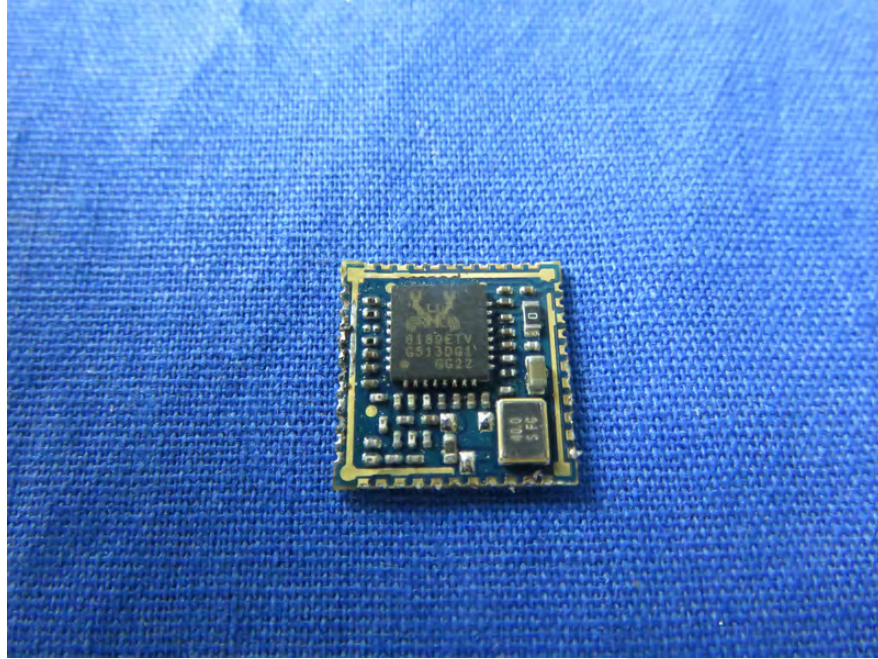

8. Figure
PCB of the EUT-Back View

