

**ELECTROMAGNETIC EMISSIONS COMPLIANCE REPORT
INTENTIONAL RADIATOR CERTIFICATION TO
FCC PART 15 SUBPART C
REQUIREMENT T**

OF

COOLER SPEAKER

MODEL No.: M5,M5- II

Trademark: N/A

FCC ID:2ACF2-M5

REPORT NO: ES160606013E

ISSUE DATE: June 17, 2016

Prepared for

NINGBO RIXING ELECTRONICS CO.,LTD

INDUSTRIAL ZONE, WUXIANG TOWN,NINGBO,China

Prepared by

EMTEK (SHENZHEN) CO., LTD

Bldg 69, Majialong Industry Zone, Nanshan District,
Shenzhen, Guangdong, China

TEL:0086-755-26954280

FAX: 0086-755-26954282

VERIFICATION OF COMPLIANCE

Applicant	:	NINGBO RIXING ELECTRONICS CO.,LTD INDUSTRIAL ZONE, WUXIANG TOWN,NINGBO,China
Manufacturer	:	NINGBO RIXING ELECTRONICS CO.,LTD INDUSTRIAL ZONE, WUXIANG TOWN,NINGBO,China
Product Description	:	COOLER SPEAKER
Brand Name	:	N/A
Model Number	:	M5,M5-II (Models of M5 and M5-II belong to the same series.M5 has wireless microphone receiver function and M5-II without this feature. Both models are not the same shape of the covers,other portions are the same. We prepare M5 for test. and the worst result recorded in the report)
File Number	:	ES160606013E
Date of Test:	:	May 10, 2016 to June 14 , 2016

We hereby certify that:

The above equipment was tested by EMTEK (SHENZHEN) CO., LTD. The test data, data evaluation, test procedures, and equipment configurations shown in this report were made in accordance with the procedures given in ANSI C63.10-2013 and the energy emitted by the sample EUT tested as described in this report is in compliance with conducted and radiated emission limits of FCC Rules Part 15.247.

The test results of this report relate only to the tested sample identified in this report.

Date of Test : May 10, 2016 to June 14 , 2016

Prepared by : 
Joe Xia /Editor

Reviewer : 
Yaping Shen /Supervisor

Approve & Authorized Signer : 
Lisa Wang/Manager

TABLE OF CONTENTS

1. GENERAL INFORMATION	5
1.1 Product Description	5
1.2 Related Submittal(s) / Grant (s).....	5
1.3 Test Methodology	5
1.4 Special Accessories	5
1.5 Equipment Modifications	5
1.6 Test Facility.....	6
2. SYSTEM TEST CONFIGURATION.....	7
2.1 EUT Configuration	7
2.2 EUT Exercise.....	7
2.3 Test Procedure	7
2.4 Limitation	8
2.5 Configuration of Tested System	10
2.6 Equipment Used in Tested System	11
2.7 Description of Test Modes.....	11
3. SUMMARY OF TEST RESULTS	12
4. CONDUCTED EMISSIONS TEST	13
4.1 Measurement Procedure	13
4.2 Test SET-UP (Block Diagram of Configuration).....	13
4.3 Measurement Equipment Used	13
4.4 Measurement Equipment Used.....	13
5. RADIATED EMISSION TEST	18
5.1 Measurement Procedure	18
5.2 Test SET-UP (Block Diagram of Configuration).....	18
5.3 Measurement Equipment Used	19
5.4 Measurement Result	19
6. CHANNEL SEPARATION TEST.....	25
6.1 Measurement Procedure	25
6.2 Test SET-UP (Block Diagram of Configuration).....	25
6.3 Measurement Equipment Used	25
6.4 Measurement Results.....	25
7. BANDWIDTH TEST	30
7.1 Measurement Procedure	30
7.2 Test SET-UP (Block Diagram of Configuration).....	30
7.3 Measurement Equipment Used	30
7.4 Measurement Results.....	30

8. QUANTITY OF HOPPING CHANNEL TEST	35
8.1 Measurement Procedure	35
8.2 Test SET-UP (Block Diagram of Configuration)	35
8.3 Measurement Equipment Used	35
8.4 Measurement Results	35
9. TIME OF OCCUPANCY (DWELL TIME) TEST	37
9.1 Measurement Procedure	37
9.2 Test SET-UP (Block Diagram of Configuration)	37
9.3 Measurement Equipment Used	37
9.4 Measurement Results	37
10. MAXIMUM PEAK OUTPUT POWER TEST	48
10.1 Measurement Procedure	48
10.2 Test SET-UP (Block Diagram of Configuration)	48
10.3 Measurement Equipment Used	48
10.4 Measurement Results	48
11. BAND EDGE TEST	53
11.1 Applicable Standard	53
11.2 Measurement Procedure	53
11.3 Measurement Equipment Used	53
11.4 Measurement Results	53
12. ANTENNA PORT EMISSION	70
12.1 Test Equipment	70
12.2 Measuring Instruments and setting	70
12.3 Test Procedures	70
12.4 Block Diagram of Test setup	70
12.5 Test Result	70
13. ANTENNA APPLICATION	73
13.1 Antenna requirement	73
13.2 Result	73

1. General Information

1.1 Product Description

NINGBO RIXING ELECTRONICS CO.,LTD

Model: M5 (referred to as the EUT in this report) The EUT (COOLER SPEAKER) is an short range, lower power Device. It is designed by way of utilizing the GFSK, $\pi/4$ -DQPSK modulation achieves the system operating.

A major technical descriptions of EUT is described as following:

- A). Operation Frequency: 2402-2480MHz
- B). Modulation: GFSK, $\pi/4$ -DQPSK
- C). Number of Channel: 79
- D). Channel Space: 1MHz
- E). BIT Rate of Transmission: 1Mbps, 2Mbps
- F). Antenna Type: PCB antenna
- G). Antenna Gain: 0.68dBi
- H). AC Supply: INPUT AC 100-240V, 50/60Hz 1.6A
OUTPUT DC 15V 4A
- I).DC Supply:DC 12V lead-acid battery

1.2 Related Submittal(s) / Grant (s)

This submittal(s) (test report) is intended for 2ACF2-M5 filing to comply with Section 15.247 of the FCC Part 15 Subpart C Rules.

1.3 Test Methodology

Both conducted and radiated testing were performed according to the procedures in ANSI C63.10 -2013. Radiated testing was performed at an antenna to EUT distance 3 meters.

1.4 Special Accessories

Not available for this EUT intended for grant.

1.5 Equipment Modifications

Not available for this EUT intended for grant.

1.6 Test Facility

Site Description
EMC Lab. :

Accredited by CNAS, 2013.10.29
The certificate is valid until 2016.10.28
The Laboratory has been assessed and proved to be in compliance with CNAS/CL01:2006(identical to ISO/IEC17025: 2005)
The Certificate Registration Number is L2291

Accredited by TUV Rheinland Shenzhen 2010.5.25
The Laboratory has been assessed according to the requirements ISO/IEC 17025

Accredited by FCC, April 17, 2014
The Certificate Registration Number is 406365.

Accredited by Industry Canada, November 29, 2012
The Certificate Registration Number is 4480A-4

Name of Firm : EMTEK (SHENZHEN) CO., LTD
Site Location : Bldg 69, Majialong Industry Zone, Nanshan District, Shenzhen, Guangdong, China

2. System Test Configuration

2.1 EUT Configuration

The EUT configuration for testing is installed on RF field strength measurement to meet the Commissions requirement and operating in a manner which intends to maximize its emission characteristics in a continuous normal application.

2.2 EUT Exercise

The Transmitter was operated in the normal operating mode. The Tx frequency was fixed which was for the purpose of the measurements.

2.3 Test Procedure

2.3.1 Conducted Emissions

The EUT is placed on a turn table which is 0.8 m above ground plane. According to the requirements in Section 6.2 of ANSI C63.10-2013, conducted emissions from the EUT are measured in the frequency range between 0.15 MHz and 30 MHz using CISPR Quasi-Peak and average detector mode.

2.3.2 Radiated Emissions

The turn table shall rotate 360 degrees to determine the position of maximum emission level. EUT is set 3m away from the receiving antenna which varied from 1m to 4m to find out the highest emission. And also, each emission was to be maximized by changing the polarization of receiving antenna both horizontal and vertical. In order to find out the max. emission, the relative positions of this KoolMAX 40-Quart Wheeled Cooler, Bluetooth PA System and Charging Station (EUT) were rotated through three orthogonal axes according to the requirements in section 6.4, section 6.5 and section 6.6 of ANSI C63.10-2013.

2.4 Limitation

(1) Channel Separation Test

FCC Part 15, Subpart C Section 15.247(a)(1) Frequency hopping systems shall have hopping channel carrier frequencies separated by a minimum of 25kHz or the 20dB Bandwidth of the hopping channel, whichever is greater.

Frequency Range (MHz)	Limit(kHz)
902-928	>25kHz
2400-2483.5	>25kHz
5725-5850	>25kHz

(2) 20dB Bandwidth

Frequency Range(MHz)	Quantity of Hopping Channel	Limit(kHz)			
		50	25	15	75
902-928		<250	>250	NA	NA
2400-2483.5		NA	NA	>1000	<1000

(3) Quantity of Hopping Channel

FCC Part 15, Subpart C Section 15.247

Frequency Range (MHz)	20dB bandwidth <250kHz	Limit(Quantity of Hopping Channel)		
		20dB bandwidth >250k Hz	20dB bandwidth <1MHz	20dB bandwidth >1MHz
902-928	50	25	NA	NA
2400-2483.5	NA	NA	75	15
5725-5850	NA	NA	75	NA

(4) Time of Occupancy(Dwell Time)

FCC Part 15, Subpart C Section 15.247

Frequency Range (MHz)	20dB bandwidth <250kHz(50Channel)	LIMIT(rms)	
		20dB bandwidth >250kHz(25 Channel)	20dB bandwidth <1MHz(75Channel)
902-928	400(20S)	400(10S)	NA
2400-2483.5	NA	NA	400(30S)
5725-5850	NA	NA	400(30S)

Note: The “()” is all channel’s average time of occupancy.

(5) Maximum Peak Output Power

FCC Part 15, Subpart C Section 15.247

Frequency Range (MHz)	Quantity of Hopping Channel	LIMIT(W)			
		50	25	15	75
902-928		1(30dBm)	0.125(21dBm)	NA	NA
2400-2483.5		NA	NA	0.125(21dBm)	1(30dBm)
5725-5850		NA	NA	NA	1(30dBm)

(6) Band edge

FCC Part15, Subpart C Section 15.247, In any 100kHz bandwidth outside the frequency band in with the spread spectrum intentional radiator is operating, the radio frequency power that is produced by the intentional radiator shall be at least 20dB below that in the 100kHz bandwidth within the band that contains the highest level of the desired power, based on either an RF conducted or a radiated measurement, attenuation below the general limits specified in section 15.209(a) is not required. In addition, radiated emissions which fall in the restricted bands, as defined in section 15.205(a), must also comply with the radiated emission limits specified in section 15.209(a).

Operating Frequency Range(MHz)	Spurious emission frequency	Limit Peak power ration to emission(dBc)	Emission level(dBuV/m)
	>928	>20	NA
	960-1240	NA	54
2400-2483.5	<2400	>20	NA
	>2483.5-2500	NA	54
5725-5850	<5350-5460	NA	54
	<5725	>20	NA
	>5850	>20	NA

(7) Conducted Emission

Frequency(MHz)	Quasi-peak	Average
0.15-0.5	66-56	56-46
0.5-5.0	56	46
5.0-30.0	60	50

Note:

1. The lower limit shall apply at the transition frequencies
2. The limit decreases in line with the logarithm of the frequency in the range of 0.15 to 0.50MHz.

(8) Radiated Emission

FCC Part 15, Subpart C Section 15.209 limit of radiated emission for frequency below 1000GHz. The emissions from an intentional radiator shall not exceed the field strength level specified in the following table:

Frequency (MHz)	Field strength $\mu\text{V/m}$	Distance(m)	Field strength at 3m $\text{dB}\mu\text{V/m}$
0.009~0.490	2400/F(KHz)	300	/
0.490~1.705	2400/F(KHz)	30	/
1.705~30.0	30	30	/
30-88	100	3	40
88-216	150	3	43.5
216-960	200	3	46
Above 960	500	3	54

- Remark:
1. Emission level in $\text{dB}\mu\text{V/m} = 20 \log(\mu\text{V/m})$
 2. Measurement was performed at an antenna to the closed point of EUT distance of meters.
 3. Distance extrapolation factor $= 40 \log(\text{Specific distance} / \text{test distance})$ (dB);
Limit line = Specific limits (dB μV) + distance extrapolation factor.

2.5 Configuration of Tested System



2.6 Equipment Used in Tested System

Item	Equipment	Mfr/Brand	Model/Type No.	FCC ID	Series No.	Note
1.	COOLER SPEAKER	N/A	M5	2ACF2-M5	N/A	EUT

Note:

- (1) Unless otherwise denoted as EUT in 『Remark』 column, device(s) used in tested system is a support equipment.

2.7 Description of Test Modes

The EUT (COOLER SPEAKER) has been tested under normal operating condition. This EUT is a FHSS system. Pre-scanned tests, were conducted to determine the final configuration from all possible combinations. We use software control the EUT, Let EUT hopping on and transmit with highest power, all the modes have been tested. 79 Channels are provided by EUT. The 3 channels of lower, medium and higher were chosen for test

Channel	Frequency(MHz)
Low channel	2402
Middle channel	2441
High channel	2480

3. Summary of Test Results

FCC Rules	Description Of Test	Result
FCC Part 15.247(a)(1)	Channel Separation Test	Compliant
FCC Part 15.247(a)(1)	20dB Bandwidth	Compliant
FCC Part 15.247(a)(1)	Quantity of Hopping Channel	Compliant
FCC Part 15.247(a)(1)	Time of Occupancy (Dwell Time)	Compliant
FCC Part 15.247(b)	Max Peak Output Power Test	Compliant
FCC Part 15.247(d)	Band Edge Test	Compliant
FCC Part 15.207	Conducted Emission	Compliant
FCC Part 15.247(d)&15.209	Radiated Emission	Compliant
FCC Part 15.247(d)	Antenna Port Emission	Compliant
FCC Part 15.203&15.247(b)	Antenna Requirement	Compliant

4. Conducted Emissions Test

4.1 Measurement Procedure

1. The EUT was placed on a table which is 0.1m above ground plane.
2. Maximum procedure was performed on the three highest emissions to ensure EUT compliance.
3. Repeat above procedures until all frequency measured were complete.

4.2 Test SET-UP (Block Diagram of Configuration)

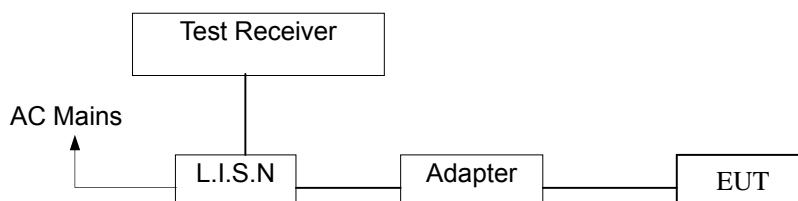

4.3 Measurement Equipment Used

Conducted Emission Test Site					
EQUIPMENT TYPE	MFR	MODEL NUMBER	SERIAL NUMBER	LAST CAL.	CAL DUE.
Test Receiver	Rohde & Schwarz	ESCS30	828985/018	05/15/2016	05/14/2017
L.I.S.N.	Rohde & Schwarz	ENV216	101161	05/15/2016	05/14/2017
L.I.S.N.	Schwarzbeck	NNLK8129	8129203	05/15/2016	05/14/2017
50Ω Coaxial Switch	Anritsu	MP59B	M20531	N/A	N/A
Pulse Limiter	Rohde & Schwarz	ESH3-Z2	100006	05/15/2016	05/14/2017

4.4 Measurement Equipment Used

Pass.
Please refer to the following data.

Charging+ Bluetooth

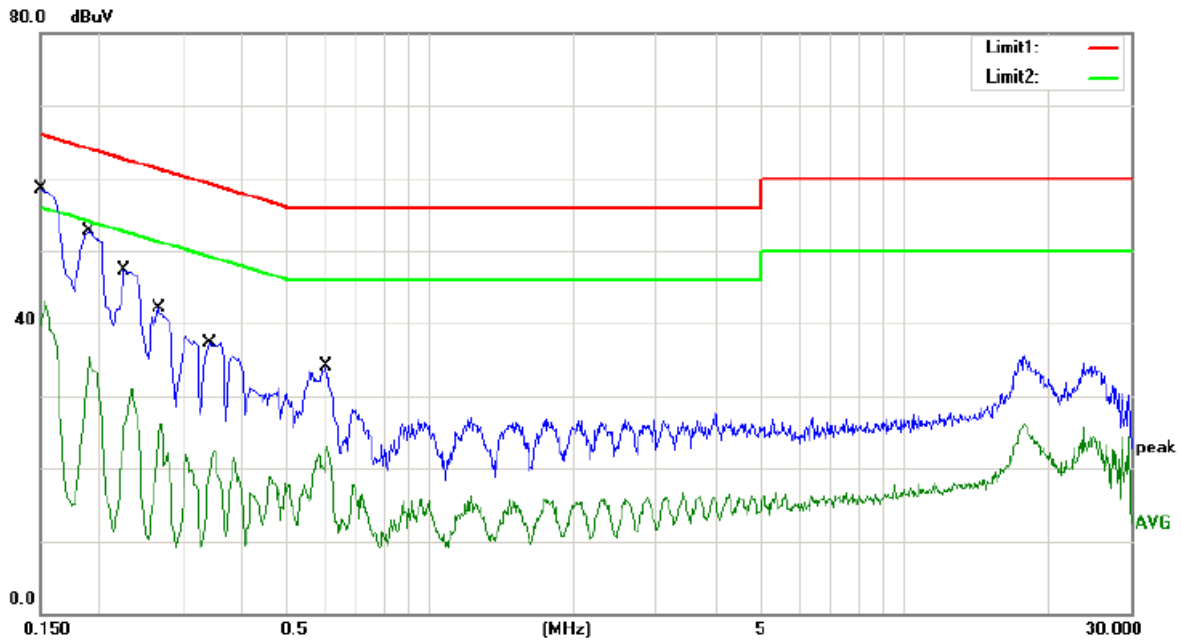

Site site #1 Phase: **L1** Temperature: 22
 Limit: (CE)FCC PART 15 class B_QP Power: AC 120V/60Hz Humidity: 50 %
 EUT: COOLER SPEAKER
 M/N: M5
 Mode: Charging+Bluetooth
 Note:

No.	Mk.	Freq. MHz	Reading Level dBuV	Correct Factor dB	Measure- ment dBuV	Limit dBuV	Over dB	Detector	Comment
1	*	0.1500	47.40	11.00	58.40	66.00	-7.60	QP	
2		0.1500	28.60	11.00	39.60	56.00	-16.40	AVG	
3		0.1900	41.70	11.00	52.70	64.04	-11.34	QP	
4		0.1900	24.20	11.00	35.20	54.04	-18.84	AVG	
5		0.2260	36.20	11.00	47.20	62.60	-15.40	QP	
6		0.2260	14.70	11.00	25.70	52.60	-26.90	AVG	
7		0.2660	31.00	11.00	42.00	61.24	-19.24	QP	
8		0.2660	13.70	11.00	24.70	51.24	-26.54	AVG	
9		0.3420	26.20	11.00	37.20	59.15	-21.95	QP	
10		0.3420	8.80	11.00	19.80	49.15	-29.35	AVG	
11		0.6020	23.00	11.00	34.00	56.00	-22.00	QP	
12		0.6020	11.30	11.00	22.30	46.00	-23.70	AVG	

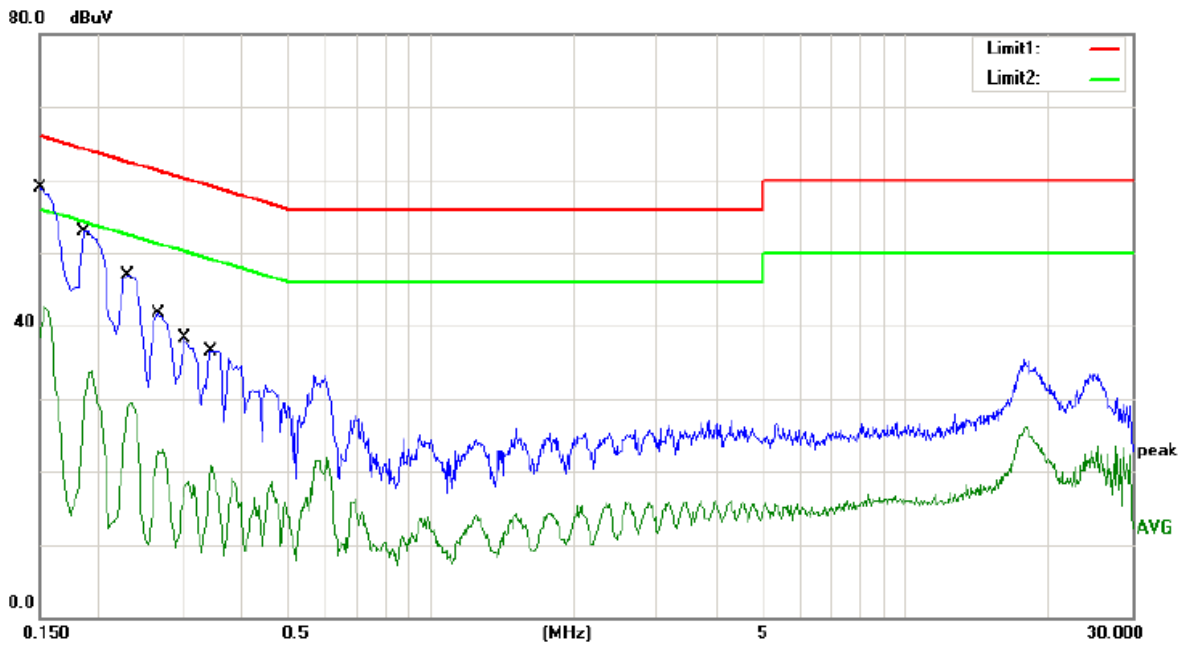

Site site #1 Phase: **N** Temperature: 22
 Limit: (CE)FCC PART 15 class B_QP Power: AC 120V/60Hz Humidity: 50 %
 EUT: COOLER SPEAKER
 M/N: M5
 Mode: Charging+Bluetooth
 Note:

No.	Mk.	Freq.	Reading Level	Correct Factor	Measurement	Limit	Over	Detector	Comment
		MHz	dBuV	dB	dBuV	dBuV	dB		
1	*	0.1500	47.90	11.00	58.90	66.00	-7.10	QP	
2		0.1500	27.40	11.00	38.40	56.00	-17.60	AVG	
3		0.1860	41.90	11.00	52.90	64.21	-11.31	QP	
4		0.1860	18.80	11.00	29.80	54.21	-24.41	AVG	
5		0.2300	35.80	11.00	46.80	62.45	-15.65	QP	
6		0.2300	17.90	11.00	28.90	52.45	-23.55	AVG	
7		0.2660	30.70	11.00	41.70	61.24	-19.54	QP	
8		0.2660	11.80	11.00	22.80	51.24	-28.44	AVG	
9		0.3020	27.30	11.00	38.30	60.19	-21.89	QP	
10		0.3020	6.50	11.00	17.50	50.19	-32.69	AVG	
11		0.3460	25.50	11.00	36.50	59.06	-22.56	QP	
12		0.3460	9.90	11.00	20.90	49.06	-28.16	AVG	

Charging+Bluetooth

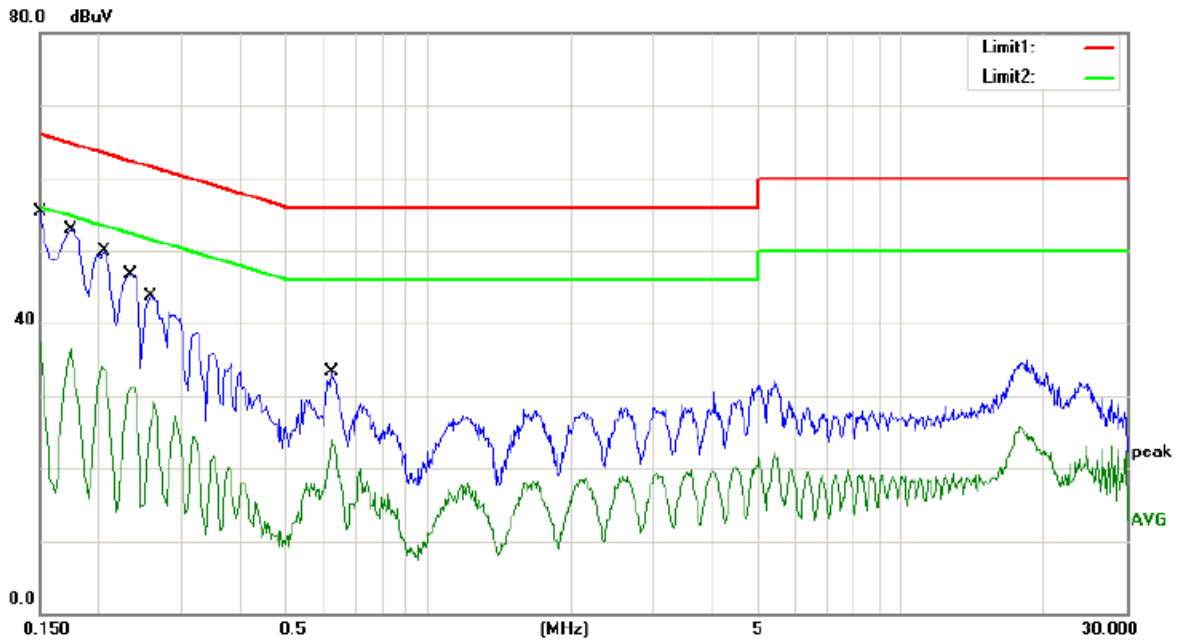

Site site #1 Phase: **N** Temperature: 22
 Limit: (CE)FCC PART 15 class B_QP Power: AC 240V/60Hz Humidity: 50 %
 EUT: COOLER SPEAKER
 M/N: M5
 Mode: Charging+Bluetooth
 Note:

No.	Mk.	Freq. MHz	Reading Level dBuV	Correct Factor dB	Measure- ment dBuV	Limit dBuV	Over dB	Detector	Comment
1	*	0.1500	44.20	11.00	55.20	66.00	-10.80	QP	
2		0.1500	26.30	11.00	37.30	56.00	-18.70	AVG	
3		0.1740	41.90	11.00	52.90	64.77	-11.87	QP	
4		0.1740	24.50	11.00	35.50	54.77	-19.27	AVG	
5		0.2040	38.90	11.00	49.90	63.45	-13.55	QP	
6		0.2040	22.80	11.00	33.80	53.45	-19.65	AVG	
7		0.2340	35.60	11.00	46.60	62.31	-15.71	QP	
8		0.2340	20.00	11.00	31.00	52.31	-21.31	AVG	
9		0.2580	32.60	11.00	43.60	61.50	-17.90	QP	
10		0.2580	15.50	11.00	26.50	51.50	-25.00	AVG	
11		0.6220	22.30	11.00	33.30	56.00	-22.70	QP	
12		0.6220	12.30	11.00	23.30	46.00	-22.70	AVG	

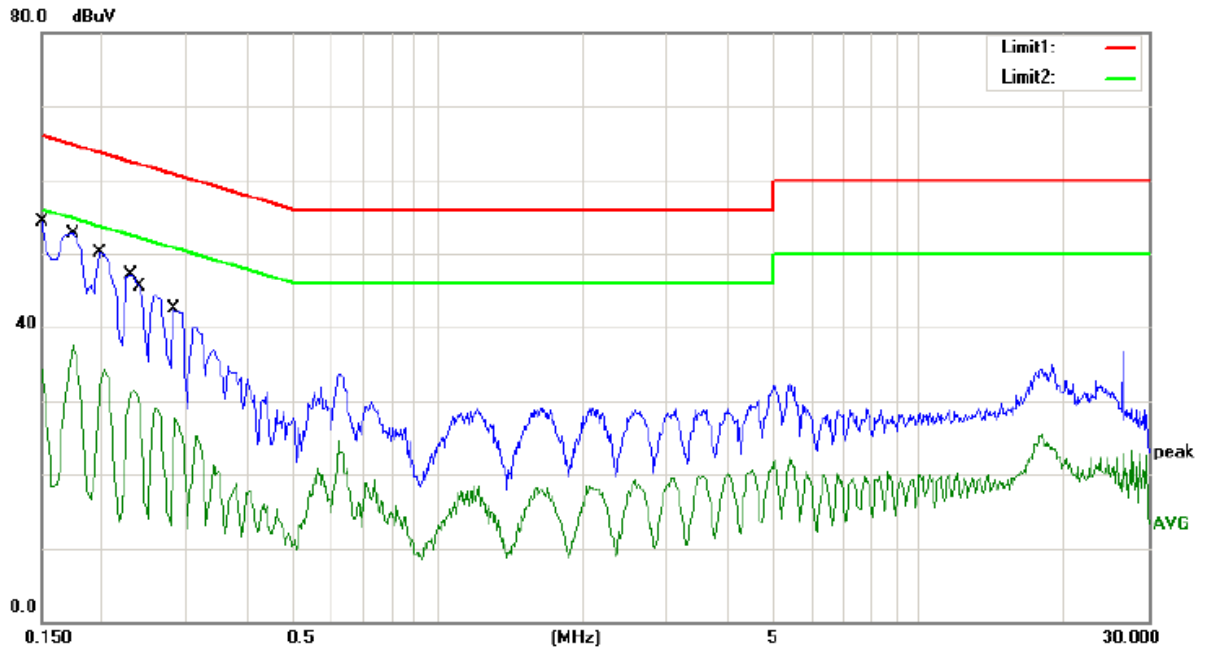

Site site #1 Phase: **L1** Temperature: 22
 Limit: (CE)FCC PART 15 class B_QP Power: AC 240V/60Hz Humidity: 50 %
 EUT: COOLER SPEAKER
 M/N: M5
 Mode: Charging+Bluetooth
 Note:

No.	Mk.	Freq.	Reading Level	Correct Factor	Measurement	Limit	Over	Detector	Comment
		MHz	dBuV	dB	dBuV	dBuV	dB		
1	*	0.1500	43.20	11.00	54.20	66.00	-11.80	QP	
2		0.1500	23.30	11.00	34.30	56.00	-21.70	AVG	
3		0.1740	41.60	11.00	52.60	64.77	-12.17	QP	
4		0.1740	26.10	11.00	37.10	54.77	-17.67	AVG	
5		0.1980	39.10	11.00	50.10	63.69	-13.59	QP	
6		0.1980	20.80	11.00	31.80	53.69	-21.89	AVG	
7		0.2300	36.10	11.00	47.10	62.45	-15.35	QP	
8		0.2300	20.10	11.00	31.10	52.45	-21.35	AVG	
9		0.2420	34.10	11.00	45.10	62.03	-16.93	QP	
10		0.2420	15.20	11.00	26.20	52.03	-25.83	AVG	
11		0.2820	31.40	11.00	42.40	60.76	-18.36	QP	
12		0.2820	13.70	11.00	24.70	50.76	-26.06	AVG	

5. Radiated Emission Test

5.1 Measurement Procedure

1. The EUT was placed on a turntable which is 0.1m above ground plane.
2. Maximum procedure was performed on the six highest emissions to ensure EUT compliance.
3. And also, each emission was to be maximized by changing the polarization of receiving antenna both horizontal and vertical.
4. Repeat above procedures until all frequency measured was complete.

The frequency range from 30MHz to 1000MHz was pre-scanned with a peak detector (RBW=100kHz, VBW=300kHz) and all final readings of measurement from Test Receiver are Quasi-Peak values(Quasi Peak detector used with a bandwidth of 120 kHz).

The frequency range above 1GHz the measuring instrument use RBW=1 MHz and VBW=3 MHz with Peak Detector for Peak Values, and use RBW=1 MHz and VBW=10 Hz with Peak Detector for Average Values.

5.2 Test SET-UP (Block Diagram of Configuration)

(A) Radiated Emission Test Set-Up, Frequency below 30MHz

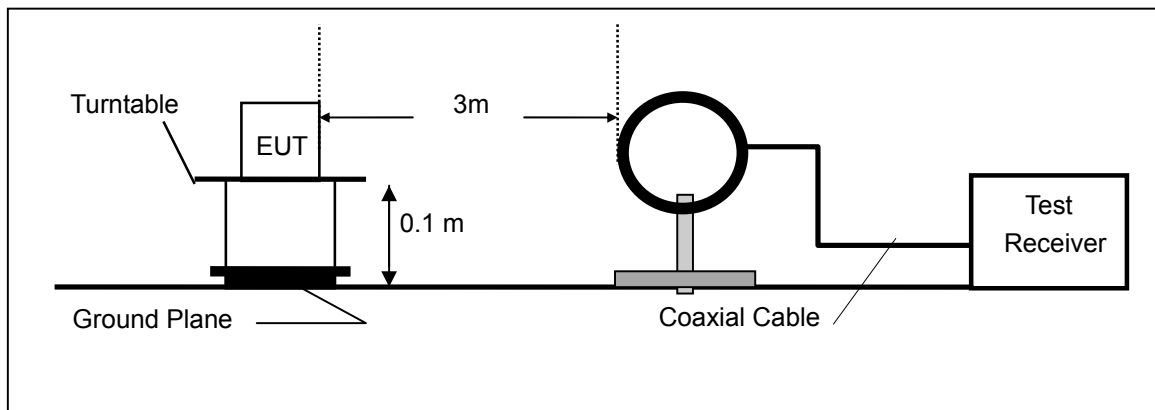

(B) Radiated Emission Test Set-Up, Frequency below 1000MHz

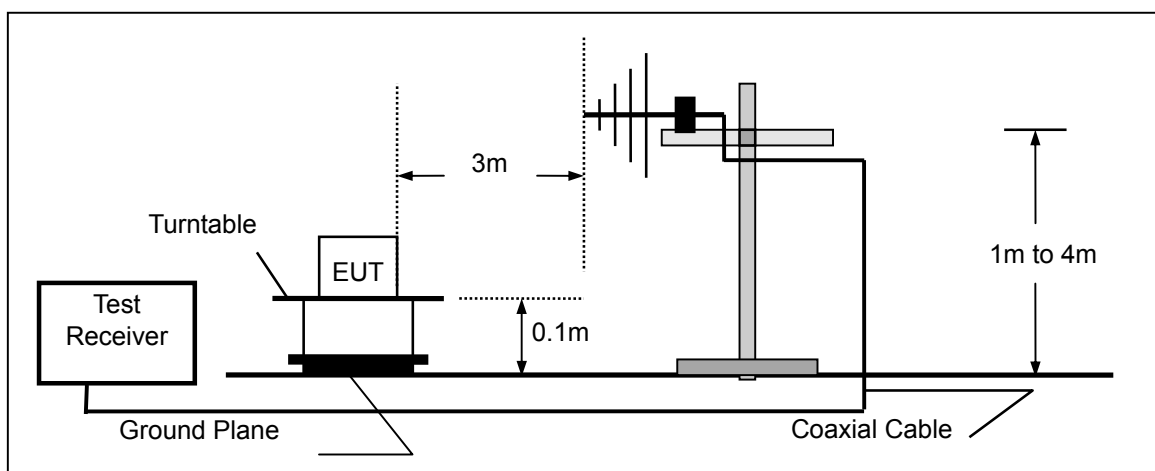

(C) Radiated Emission Test Set-Up, Frequency above 1000MHz

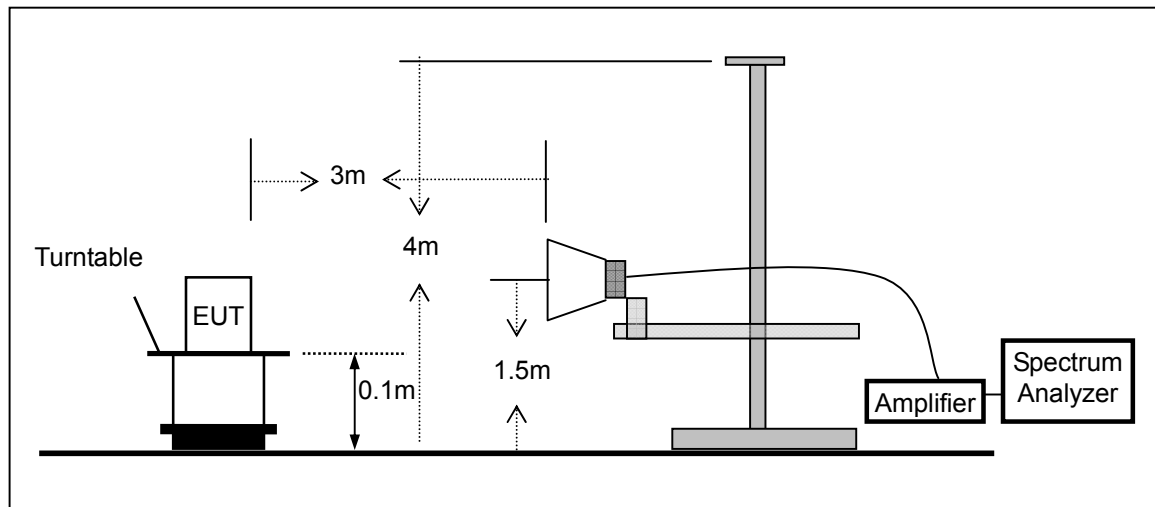

5.3 Measurement Equipment Used

Item	Equipment	Manufacturer	Model No.	Serial No.	Last Cal.	Cal. Interval
1.	EMI Test Receiver	Rohde & Schwarz	ESU	1302.6005.26	05/15/2016	1 Year
2.	Pre-Amplifier	HP	8447D	2944A07999	05/15/2016	1 Year
3.	Pre-Amplifier	A.H.	PAM-0126	1415261	05/15/2016	1 Year
4.	Bilog Antenna	Schwarzbeck	VULB9163	142	05/15/2016	1 Year
5.	Loop Antenna	Schwarzbeck	FMZB 1519	1519-012	05/15/2016	1 Year
6.	Horn Antenna	Schwarzbeck	BBHA 9170	BBHA9170399	05/15/2016	1 Year
7.	Horn Antenna	Schwarzbeck	BBHA 9120	D143	05/15/2016	1 Year
8.	Cable	Schwarzbeck	AK9513	ACRX1	05/15/2016	1 Year
9.	Cable	Rosenberger	N/A	FP2RX2	05/15/2016	1 Year
10.	Cable	Schwarzbeck	AK9513	CRPX1	05/15/2016	1 Year
11.	Cable	Schwarzbeck	AK9513	CRRX2	05/15/2016	1 Year

5.4 Measurement Result

(For range 9KHz~30MHz, The measured value is really too low to be recorded.)

Below 1000MHz (30M-1GHz)

BT Tx mode:

(Bluetooth (GFSK, pi/4-DQPSK) mode have been tested, and the worst result was report as below.)

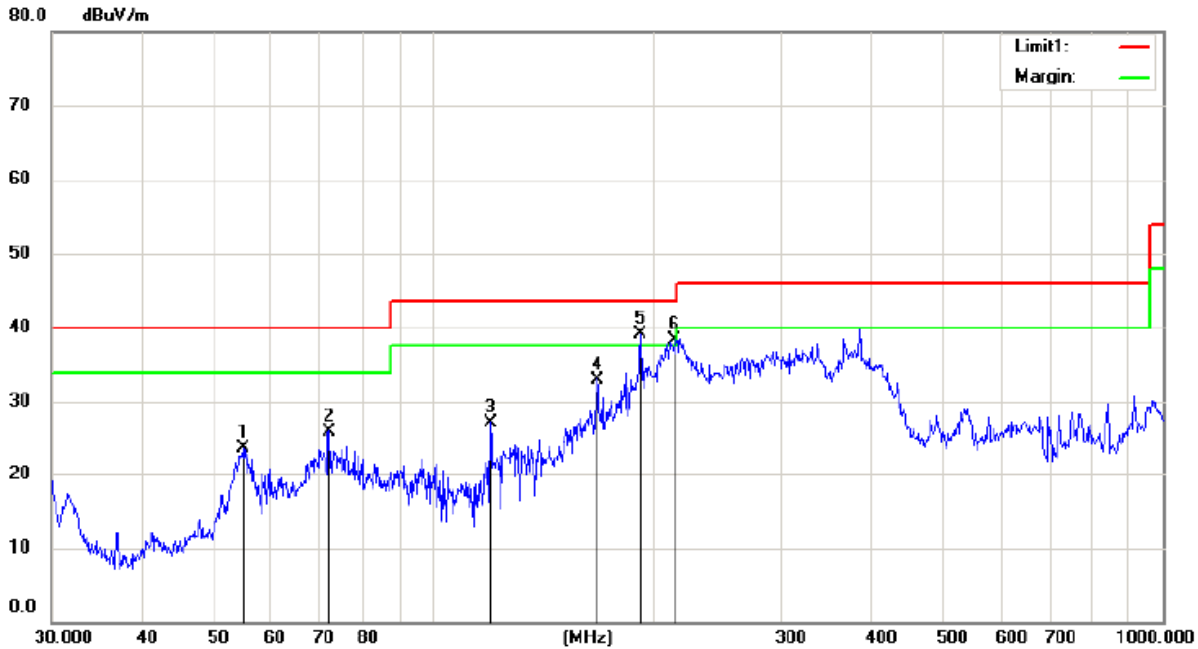

Site site #1 Polarization: **Horizontal** Temperature: 20 C
 Limit: FCC Part15 Class B 3M Radiation Power: AC 120V/60Hz Humidity: 52 %
 EUT: COOLER SPEAKER
 M/N: M5
 Mode:GFSK(2402MHz)
 Note:

No.	Mk.	Freq.	Reading Level	Correct Factor	Measurement	Limit	Over	Antenna Height	Table Degree	
		MHz	dBuV	dB	dBuV/m	dBuV/m	dB	cm	degree	Comment
1		55.0274	43.50	-19.80	23.70	40.00	-16.30			QP
2		72.0843	50.76	-24.76	26.00	40.00	-14.00			QP
3		119.8556	50.77	-23.57	27.20	43.50	-16.30			QP
4		167.8243	58.37	-25.37	33.00	43.50	-10.50			QP
5	*	192.4186	61.05	-21.95	39.10	43.50	-4.40			QP
6	!	214.5143	61.02	-22.62	38.40	43.50	-5.10			QP

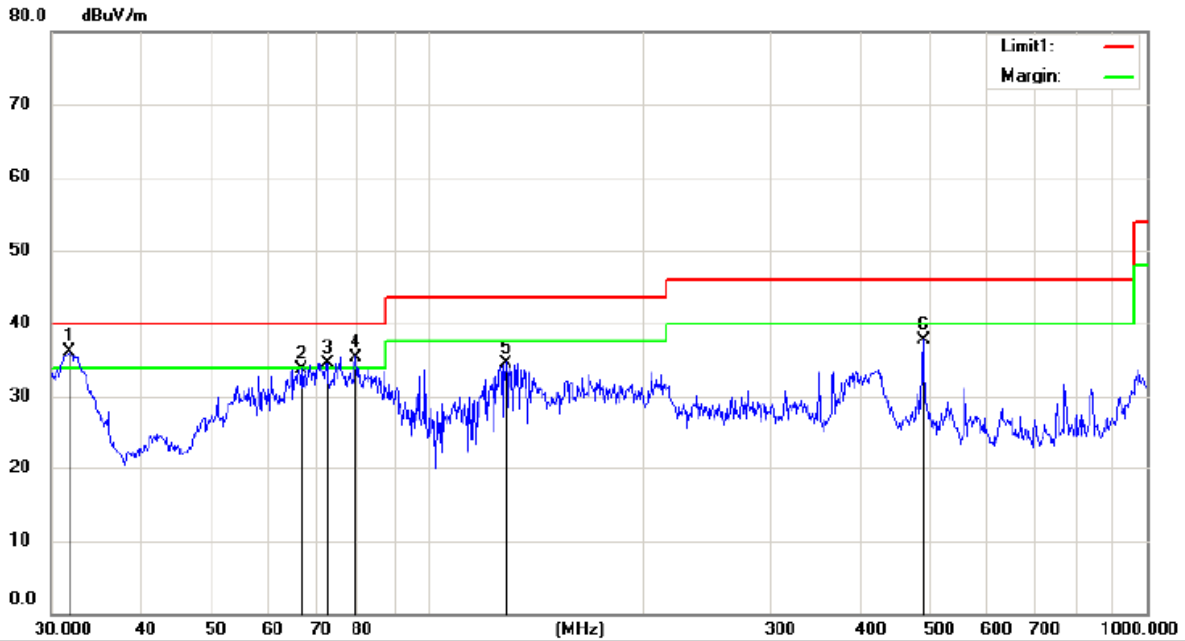

Site site #1 Polarization: **Vertical** Temperature: 20 C
 Limit: FCC Part15 Class B 3M Radiation Power: AC 120V/60Hz Humidity: 52 %
 EUT: COOLER SPEAKER
 M/N: M5
 Mode:GFSK(2402MHz)
 Note:

No.	Mk.	Freq.	Reading Level	Correct Factor	Measurement	Limit	Over	Antenna Height	Table Degree	
		MHz	dBuV	dB	dBuV/m	dBuV/m	dB	cm	degree	Comment
1	*	31.7313	59.51	-23.41	36.10	40.00	-3.90			QP
2		66.9670	57.09	-23.29	33.80	40.00	-6.20			QP
3	!	72.5916	59.43	-24.93	34.50	40.00	-5.50			QP
4	!	79.5210	61.56	-26.16	35.40	40.00	-4.60			QP
5		128.5630	59.43	-24.83	34.60	43.50	-8.90			QP
6		489.0270	52.77	-14.97	37.80	46.00	-8.20			QP

Charging+BT Playing

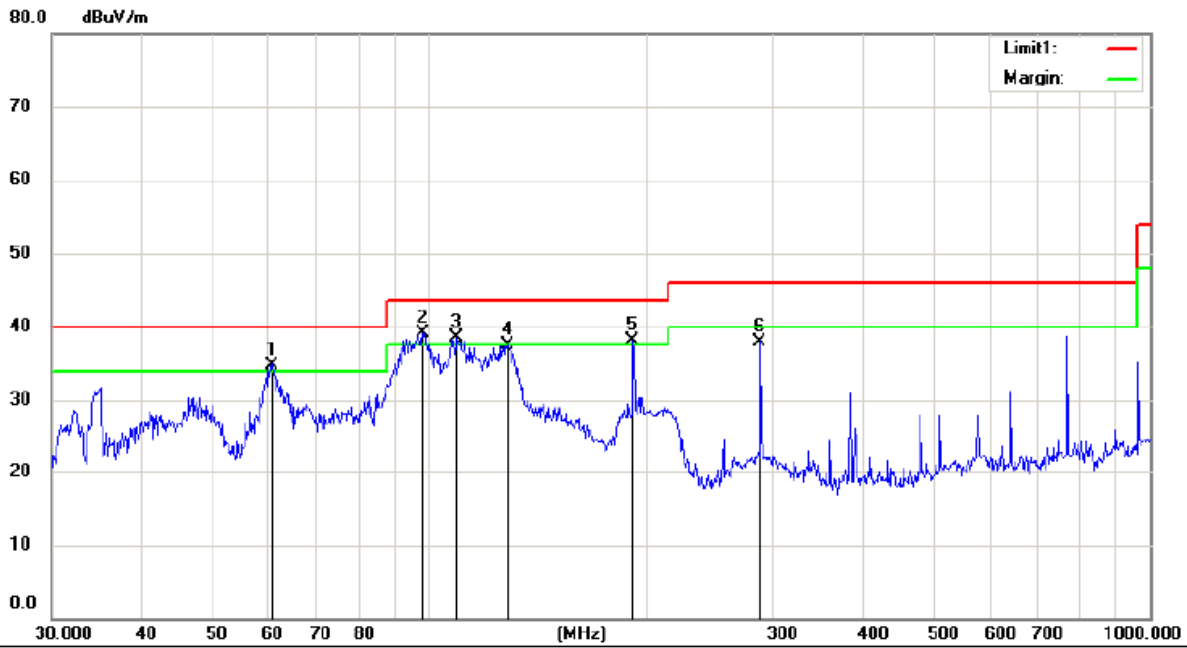

Site site #1 Polarization: *Horizontal* Temperature: 20 C
 Limit: FCC Part15 Class B 3M Radiation Power: AC 120V/60Hz Humidity: 52 %
 EUT: COOLER SPEAKER
 M/N: M5
 Mode:Charging+Bluetooth
 Note:

No.	Mk.	Freq.	Reading Level	Correct Factor	Measurement	Limit	Over	Detector	Antenna Height	Table Degree	Comment
		MHz	dBuV	dB	dBuV/m	dBuV/m	dB		cm	degree	
1	!	60.7043	56.76	-21.96	34.80	40.00	-5.20	QP			
2	*	98.1418	60.85	-21.75	39.10	43.50	-4.40	QP			
3	!	109.4116	60.28	-21.78	38.50	43.50	-5.00	QP			
4		128.5630	62.33	-24.83	37.50	43.50	-6.00	QP			
5	!	191.7450	60.12	-22.02	38.10	43.50	-5.40	QP			
6		287.9904	57.21	-19.31	37.90	46.00	-8.10	QP			

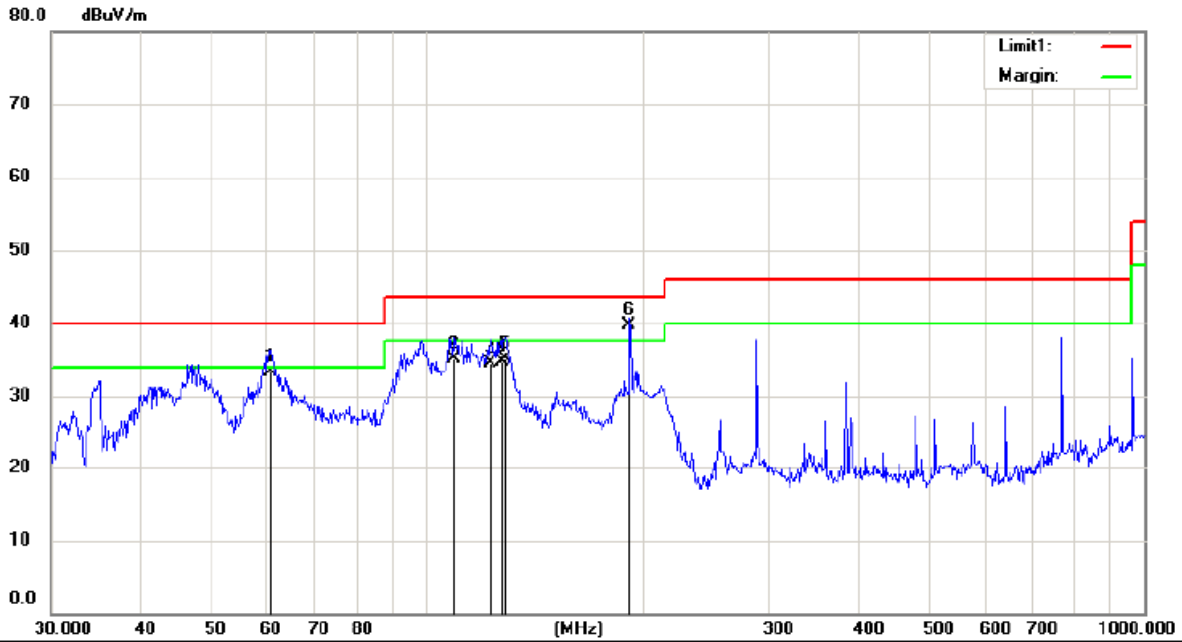

Site site #1
 Limit: FCC Part15 Class B 3M Radiation
 EUT: COOLER SPEAKER
 M/N: M5
 Mode:Charging+Bluetooth
 Note:

Polarization: *Vertical*
 Power: AC 120V/60Hz

Temperature: 20 C
 Humidity: 52 %

No.	Mk.	Freq.	Reading Level	Correct Factor	Measurement	Limit	Over	Antenna Height	Table Degree	
		MHz	dBuV	dB	dBuV/m	dBuV/m	dB	cm	degree	Comment
1		60.7044	55.26	-21.96	33.30	40.00	-6.70			QP
2		109.4116	56.88	-21.78	35.10	43.50	-8.40			QP
3		122.8340	58.42	-23.82	34.60	43.50	-8.90			QP
4		127.6645	59.31	-24.61	34.70	43.50	-8.80			QP
5		128.5630	59.93	-24.83	35.10	43.50	-8.40			QP
6	*	191.7450	61.82	-22.02	39.80	43.50	-3.70			QP

Above 1000MHz:

Bluetooth (GFSK, pi/4-DQPSK) mode have been tested, and the worst result was report as below

Test Date : 05/12/2016 Temperature : 25 °C
 Test Result: PASS Humidity : 55 %
 Test By: KK

GFSK Mode: Low channel							
Freq. (MHz)	Ant.Pol. (H/V)	Emission Level(dBuV/m)		Limit 3m(dBuV/m)		Margin(dB)	
		PK	AV	PK	AV	PK	AV
4804.000	V	59.59	47.11	74.00	54.00	-14.41	-6.89
7817.000	V	51.51	43.09	74.00	54.00	-22.49	-10.91
9976.000	V	52.56	41.62	74.00	54.00	-21.44	-12.38
13155.000	V	53.37	43.33	74.00	54.00	-20.63	-10.67
15926.000	V	54.07	40.97	74.00	54.00	-19.93	-13.03
17847.000	V	58.58	44.71	74.00	54.00	-19.42	-13.29
4804.000	H	55.57	42.76	74.00	54.00	-15.42	-9.29
8344.000	H	55.55	41.38	74.00	54.00	-18.45	-12.62
11064.000	H	53.65	39.67	74.00	54.00	-20.35	-14.33
13461.000	H	55.37	41.29	74.00	54.00	-18.63	-12.71
17014.000	H	55.08	40.38	74.00	54.00	-18.92	-13.62
18000.000	H	52.37	41.61	74.00	54.00	-21.63	-12.39

GFSK Mode: Middle channel							
Freq. (MHz)	Ant.Pol. (H/V)	Emission Level(dBuV/m)		Limit 3m(dBuV/m)		Margin(dB)	
		PK	AV	PK	AV	PK	AV
4882.000	V	57.66	44.67	74.00	54.00	-16.34	-9.33
8599.000	V	52.39	38.20	74.00	54.00	-21.61	-15.80
11319.000	V	52.92	40.58	74.00	54.00	-21.08	-13.42
14430.000	V	52.81	41.80	74.00	54.00	-21.19	-12.20
16402.000	V	54.18	42.10	74.00	54.00	-19.82	-11.90
17983.000	V	52.09	41.24	74.00	54.00	-21.91	-12.76
4882.000	H	58.82	46.07	74.00	54.00	-15.18	-7.93
8412.000	H	53.31	42.17	74.00	54.00	-20.69	-11.83
9636.000	H	52.72	39.29	74.00	54.00	-21.28	-14.71
11523.000	H	52.16	43.10	74.00	54.00	-21.84	-10.90
14515.000	H	50.58	43.24	74.00	54.00	-23.42	-10.76
16793.000	H	52.24	40.46	74.00	54.00	-21.76	-13.54

GFSK Mode: High channel							
Freq. (MHz)	Ant.Pol. (H/V)	Emission Level(dBuV/m)		Limit 3m(dBuV/m)		Margin(dB)	
		PK	AV	PK	AV	PK	AV
4960.000	V	57.40	45.34	74.00	54.00	-16.60	-8.66
8582.000	V	51.12	41.82	74.00	54.00	-22.88	-12.18
9449.000	V	52.88	42.47	74.00	54.00	-21.12	-11.53
12271.000	V	52.98	39.90	74.00	54.00	-21.02	-14.10
13767.000	V	55.05	41.76	74.00	54.00	-18.95	-12.24
16470.000	V	52.31	41.13	74.00	54.00	-21.69	-12.87
4960.000	H	58.12	46.83	74.00	54.00	-15.88	-7.17
8565.000	H	53.06	40.53	74.00	54.00	-20.94	-13.47
9551.000	H	52.50	39.55	74.00	54.00	-21.50	-14.45
12696.000	H	52.79	40.30	74.00	54.00	-21.21	-13.70
15450.000	H	49.69	41.98	74.00	54.00	-24.31	-12.02
18000.000	H	52.25	40.66	74.00	54.00	-21.75	-13.34

6. Channel Separation Test

6.1 Measurement Procedure

The EUT was operating in hopping mode or could be controlled its channel. Print out the test result from the spectrum by hard copy function.

6.2 Test SET-UP (Block Diagram of Configuration)

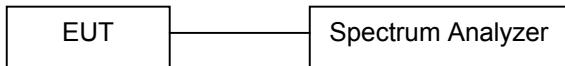

6.3 Measurement Equipment Used

Name of Equipment	Manufacturer	Model	Serial Number	Last Cal.	CAL DUE.
Spectrum Analyzer	Rohde & Schwarz	ESCI	101414	05/15/2016	05/14/2017

6.4 Measurement Results

The following table is the setting of spectrum analyzer.

Attenuation	Auto
RB	100KHz
VB	300KHz
Detector	Peak
Trace	Max hold

Refer to attached data chart.

Spectrum Detector:	PK	Test Date :	05/27/2016
Test By:	KK	Temperature :	24 °C
Test Result:	PASS	Humidity :	54 %

GFSK Mode:

Test Channel	Channel frequency (MHz)	Separation Read Value (kHz)	Separation Limit 20dB Down BW(kHz)
Low Channel	2402	1000.00	780
Adjacency Channel	2403		
Middle channel	2441	1000.00	750
Adjacency Channel	2440		
High Channel	2480	1000.00	804
Adjacency Channel	2479		

$\pi/4$ -DQPSK Mode

Test Channel	Channel frequency (MHz)	Separation Read Value (kHz)	Separation Limit 2/3 20dB Down BW(kHz)
Low Channel	2402	1000.00	808
Adjacency Channel	2403		
Middle channel	2441	1000.00	808
Adjacency Channel	2440		
High Channel	2480	1000.00	816
Adjacency Channel	2479		

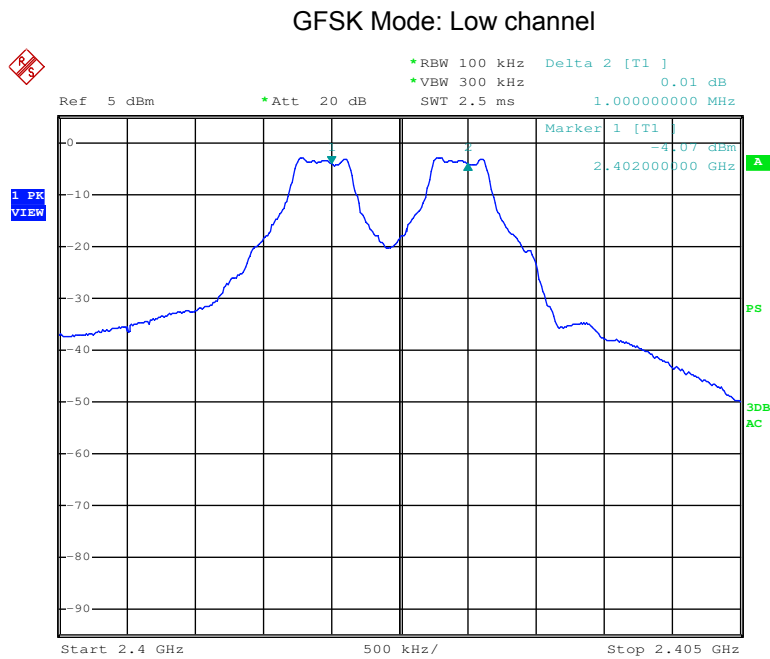

Date: 27.MAY.2016 11:32:05

GFSK Mode: Middle channel

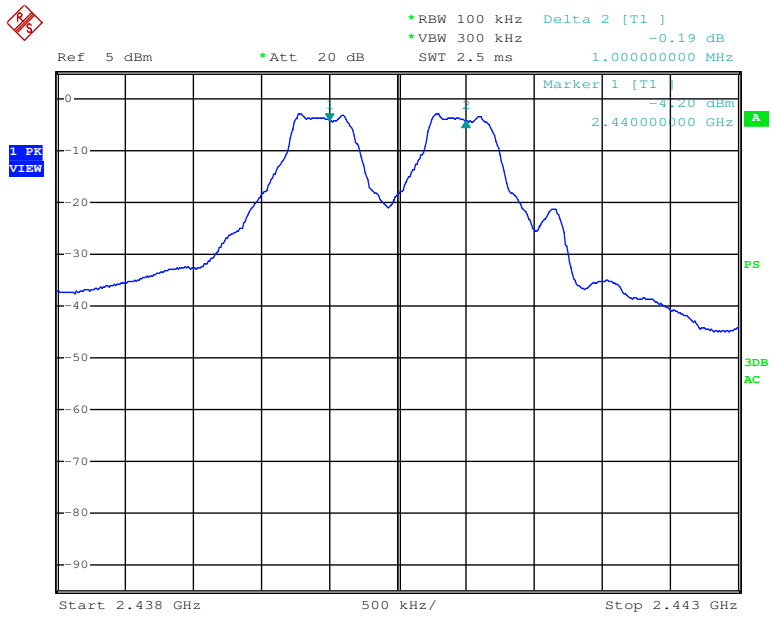

Date: 27.MAY.2016 11:34:01

GFSK Mode: High channel

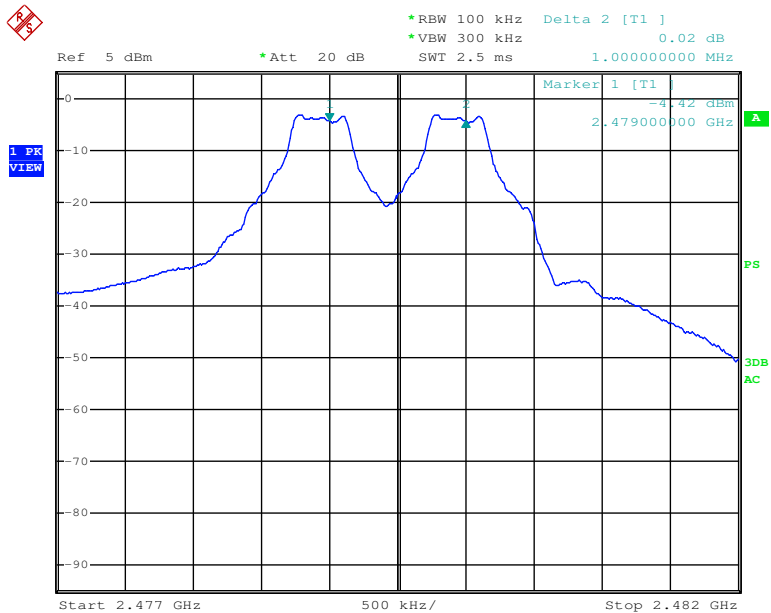

Date: 27.MAY.2016 11:35:57

$\pi/4$ -DQPSK Mode: Low channel

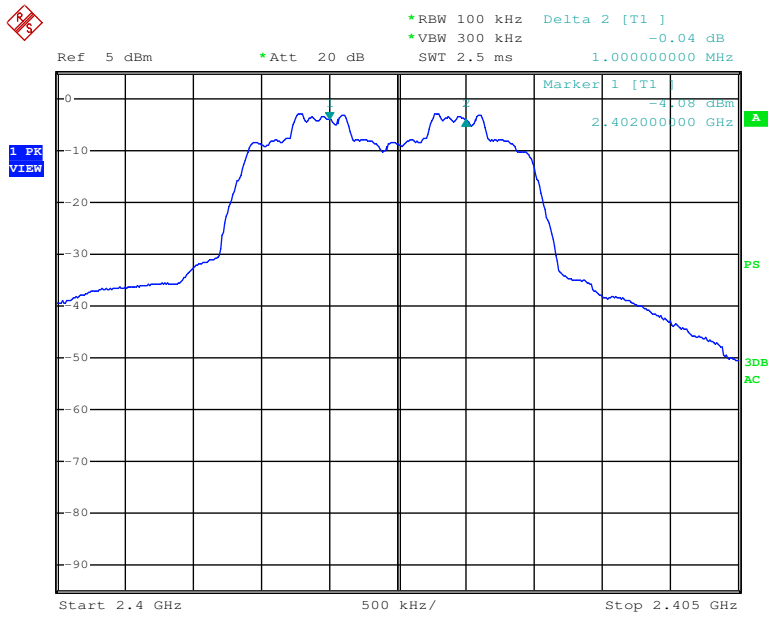

Date: 27.MAY.2016 11:37:26

$\pi/4$ -DQPSK Mode: Middle channel

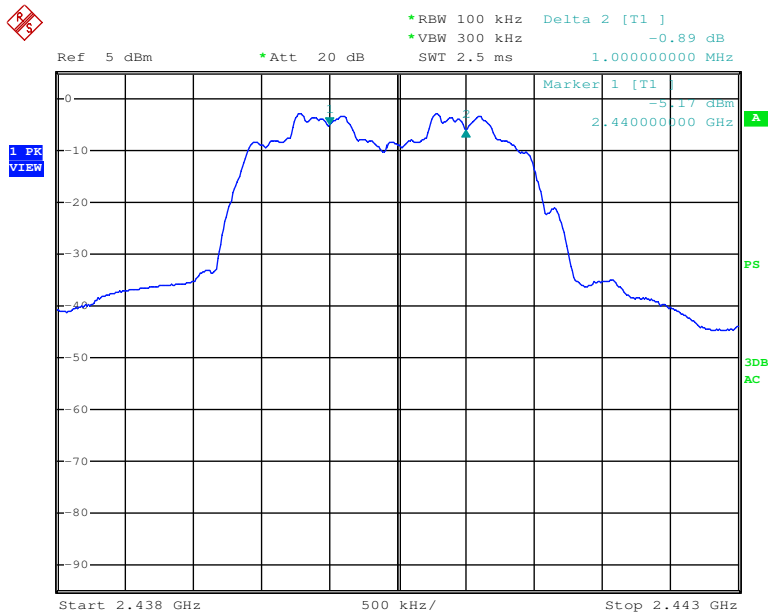

Date: 27.MAY.2016 11:40:12

$\pi/4$ -DQPSK Mode: High channel

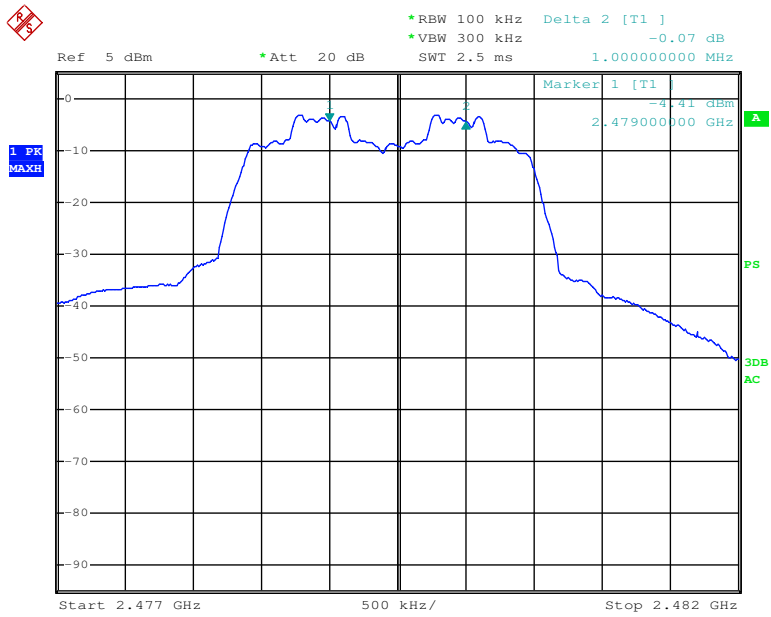

Date: 27.MAY.2016 11:43:15

7. Bandwidth Test

7.1 Measurement Procedure

The EUT was operating in hopping mode or could be controlled its channel. Print out the test result from the spectrum by hard copy function.

7.2 Test SET-UP (Block Diagram of Configuration)

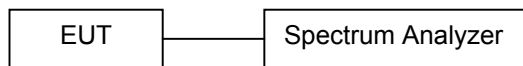

7.3 Measurement Equipment Used

Name of Equipment	Manufacturer	Model	Serial Number	Last Cal.	CAL DUE.
Spectrum Analyzer	Rohde & Schwarz	ESCI	101414	05/15/2016	05/14/2017

7.4 Measurement Results

The following table is the setting of spectrum analyzer.

Attenuation	Auto
SPAN	3MHz
RB	30KHz
VB	100KHz
Detector	Peak
Trace	Max hold

20dB Bandwidth test data Chart:

Refer to attached data chart.

Spectrum Detector:	PK	Test Date:	05/27/2016
Test By:	KK	Temperature:	24 °C
Test Result:	N/A	Humidity:	54 %

GFSK Mode:

Channel number	Channel frequency (MHz)	20dB Down BW(kHz)
Low channel	2402	780
Middle channel	2441	750
High channel	2480	804

$\pi/4$ -DQPSK Mode:

Channel number	Channel frequency (MHz)	20dB Down BW(kHz)
Low channel	2402	1212
Middle channel	2441	1212
High channel	2480	1224

GFSK Mode: Low channel

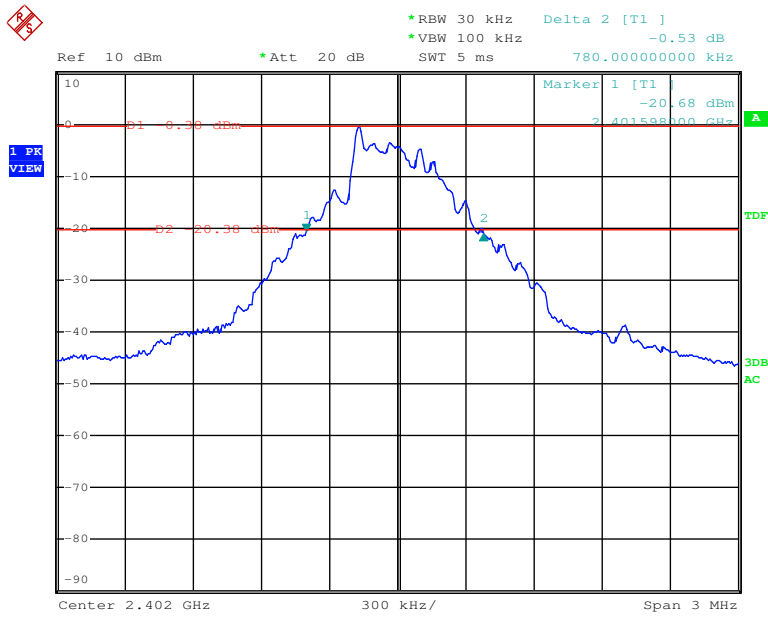

Date: 27.MAY.2016 11:08:44

GFSK Mode: Middle channel

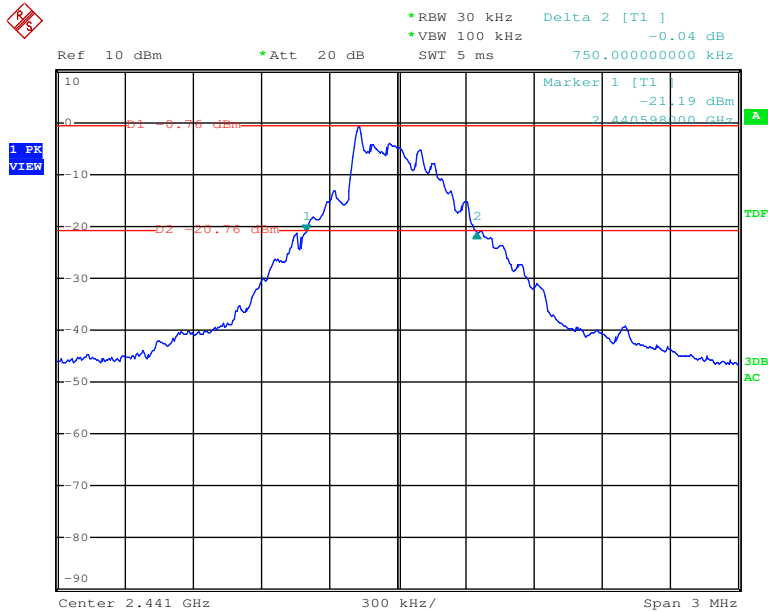

Date: 27.MAY.2016 11:09:24

GFSK Mode: High channel

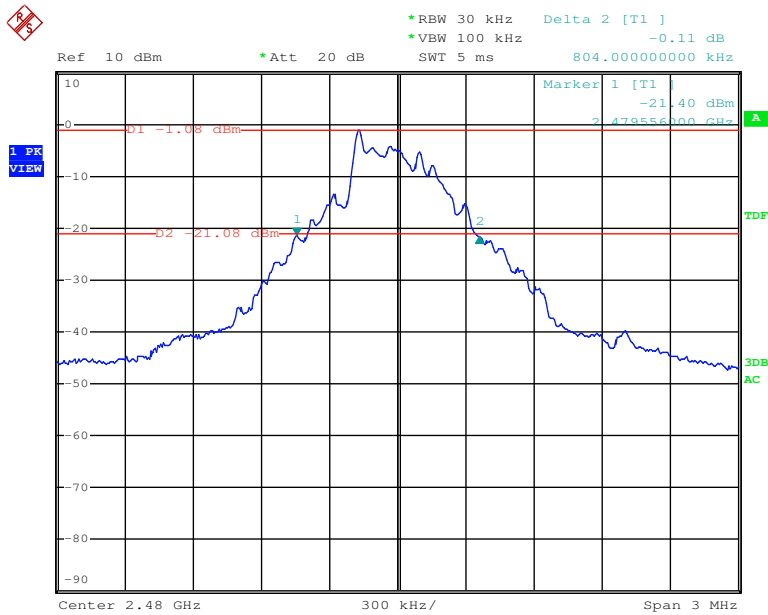

Date: 27.MAY.2016 11:10:04

$\pi/4$ -DQPSK Mode: Low channel

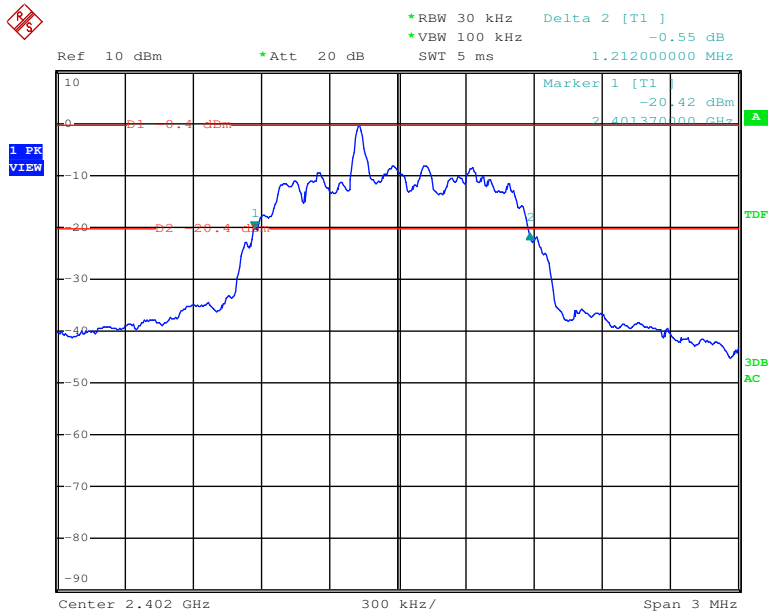

Date: 27.MAY.2016 11:10:45

$\pi/4$ -DQPSK Mode: Middle channel

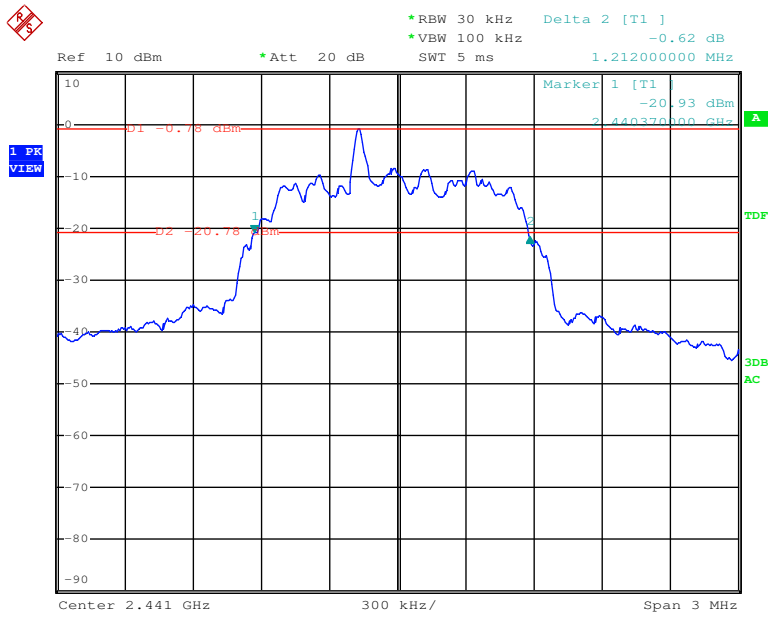

Date: 27.MAY.2016 11:11:24

$\pi/4$ -DQPSK Mode: High channel

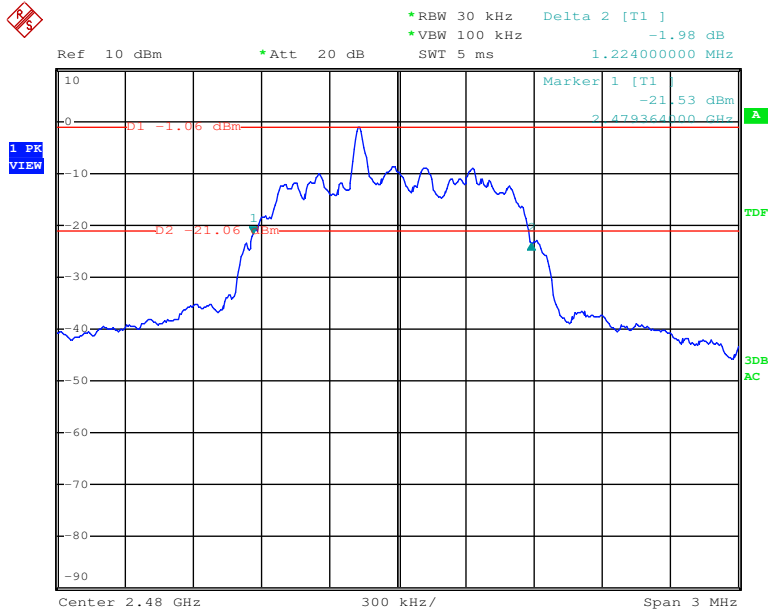

Date: 27.MAY.2016 11:12:09

8. Quantity of Hopping Channel Test

8.1 Measurement Procedure

The EUT was operating in hopping mode or could be controlled its channel. Print out the test result from the spectrum by hard copy function.

8.2 Test SET-UP (Block Diagram of Configuration)

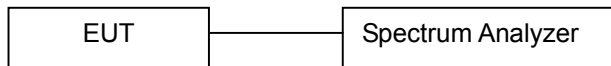

8.3 Measurement Equipment Used

Name of Equipment	Manufacturer	Model	Serial Number	Last Cal.	CAL DUE.
Spectrum Analyzer	Rohde & Schwarz	ESCI	101414	05/15/2016	05/14/2017

8.4 Measurement Results

Refer to attached data chart.

Spectrum Detector:	PK	Test Date :	05/27/2016
Test By:	KK	Temperature :	24 °C
Test Result:	Pass	Humidity :	54 %

GFSK Mode, $\pi/4$ -DQPSK Mode:

Hopping Channel Frequency Range	Quantity of Hopping Channel	Quantity of Hopping Channel limit
2402-2480	79	>15

GFSK Mode

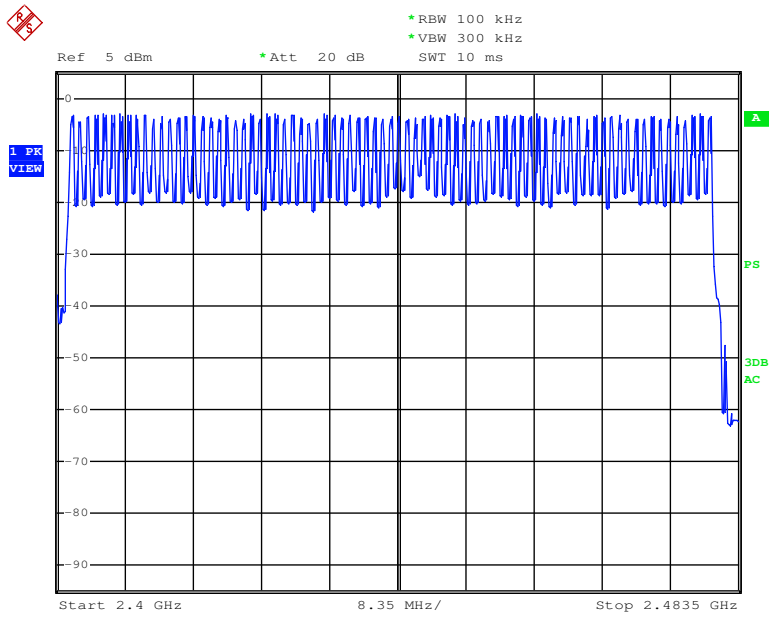

Date: 27.MAY.2016 11:28:33

$\pi/4$ -DQPSK Mode

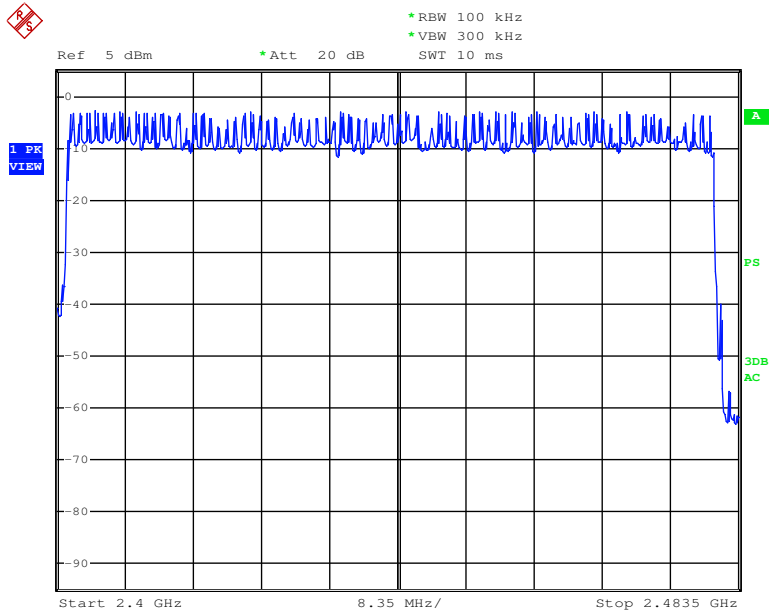

Date: 27.MAY.2016 11:30:04

9. Time of Occupancy (Dwell Time) Test

9.1 Measurement Procedure

- a. Check the calibration of the measuring instrument(SA) using either an internal calibrator or a known signal from an external generator.
- b. Turn on the EUT and connect its antenna terminal to measurement via a low loss cable. Then set it to any one measured frequency within its operating range and make sure the instrument is operated in its linear range.
- c. Adjust the center frequency of SA on any frequency be measured and set SA to zero span mode. And then, set RBW and VBW of spectrum analyzer to proper value.
- d. Measure the time duration of one transmission on the measured frequency. And then plot the result with time difference of this time duration.
- e. Repeat above procedures until all different time-slot modes have been completed.

9.2 Test SET-UP (Block Diagram of Configuration)

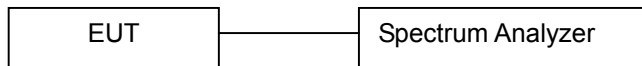

9.3 Measurement Equipment Used

Name of Equipment	Manufacturer	Model	Serial Number	Last Cal.	CAL DUE.
Spectrum Analyzer	Rohde & Schwarz	ESCI	101414	05/15/2016	05/14/2017

9.4 Measurement Results

Refer to attached data chart.

Spectrum Detector: PK
Test By: KK
Test Result: PASS

Test Date : 05/27/2016
Temperature : 24 °C
Humidity : 54 %

Mode	Channel	Pulse Width (ms)	Dwell Time (ms)	Limit (ms)	Result
GFSK Mode					
DH1	Low channel	0.370	118.4	400	Pass
	Middle channel	0.370	118.4	400	Pass
	High channel	0.370	118.4	400	Pass
	Note: Dwell time=Pulse Time (ms) × (1600 ÷ 2 ÷ 79) ×31.6 Second				
DH3	Low channel	1.633	261.3	400	Pass
	Middle channel	1.633	261.3	400	Pass
	High channel	1.633	261.3	400	Pass
	Note: Dwell time=Pulse Time (ms) × (1600 ÷ 4 ÷ 79) ×31.6 Second				
DH5	Low channel	2.880	307.2	400	Pass
	Middle channel	2.880	307.2	400	Pass
	High channel	2.873	306.5	400	Pass
	Note: Dwell time=Pulse Time (ms) × (1600 ÷ 6 ÷ 79) ×31.6 Second				
π/4-DPSK Mode					
2DH1	Low channel	0.385	123.2	400	Pass
	Middle channel	0.385	123.2	400	Pass
	High channel	0.385	123.2	400	Pass
	Note: Dwell time=Pulse Time (ms) × (1600 ÷ 2 ÷ 79) ×31.6 Second				
2DH3	Low channel	1.632	261.1	400	Pass
	Middle channel	1.632	261.1	400	Pass
	High channel	1.632	261.1	400	Pass
	Note: Dwell time=Pulse Time (ms) × (1600 ÷ 4 ÷ 79) ×31.6 Second				
2DH5	Low channel	2.912	310.6	400	Pass
	Middle channel	2.912	310.6	400	Pass
	High channel	2.912	310.6	400	Pass
	Note: Dwell time=Pulse Time (ms) × (1600 ÷ 6 ÷ 79) ×31.6 Second				

DH1: Low channel

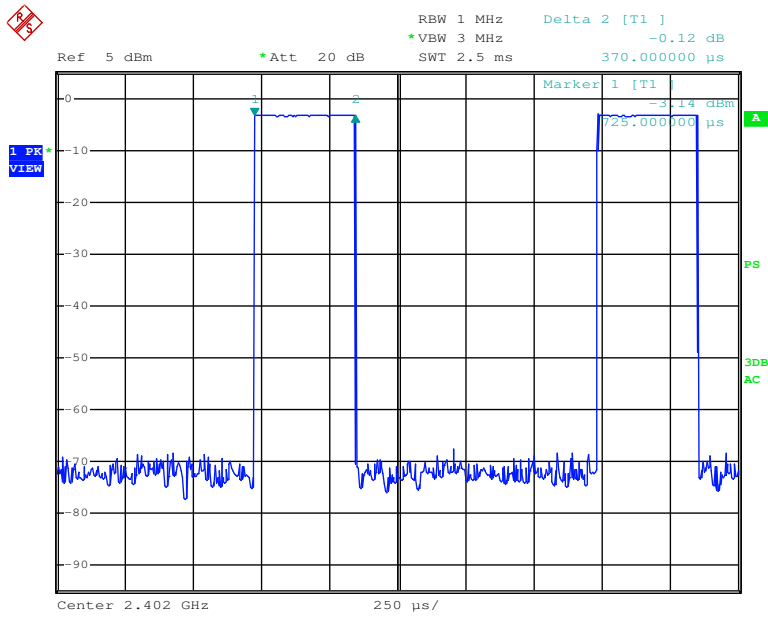

Date: 27.MAY.2016 11:44:35

DH1: Middle channel

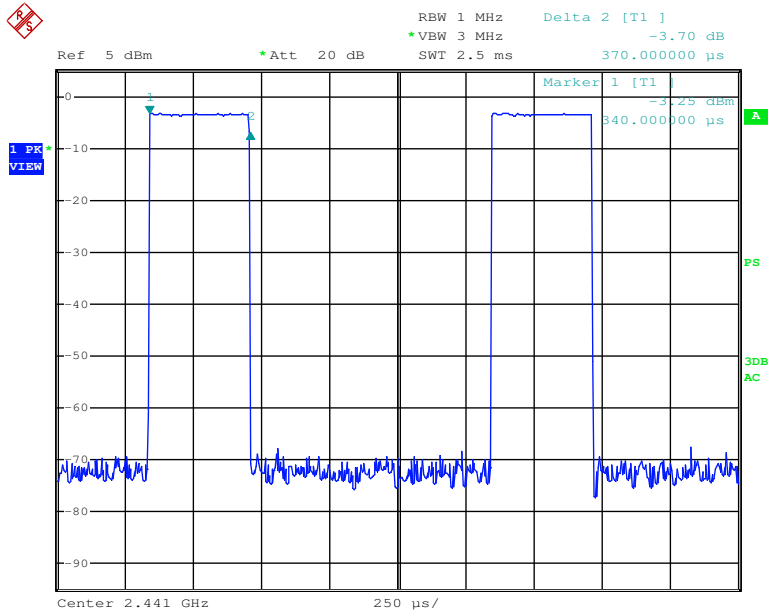

Date: 27.MAY.2016 11:45:12

DH1: High channel

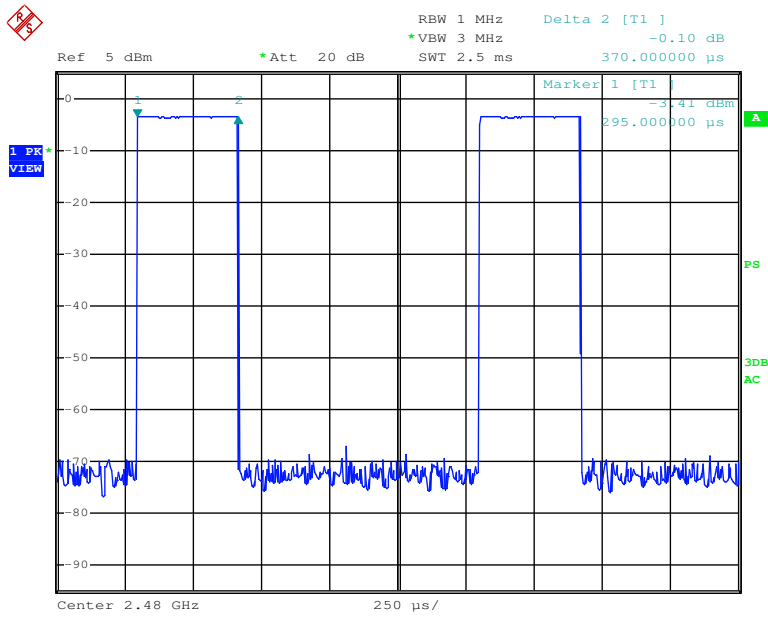

Date: 27.MAY.2016 11:46:03

DH3: Low channel

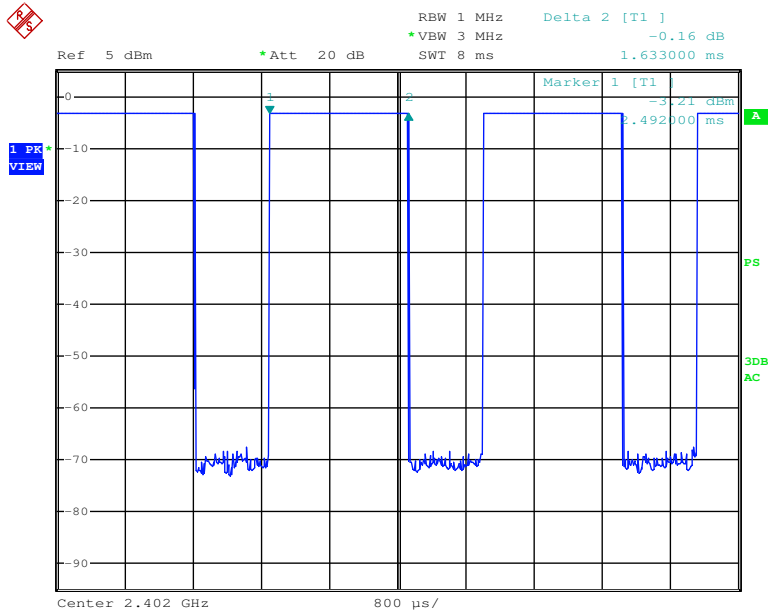

Date: 27.MAY.2016 11:51:17

DH3: Middle channel

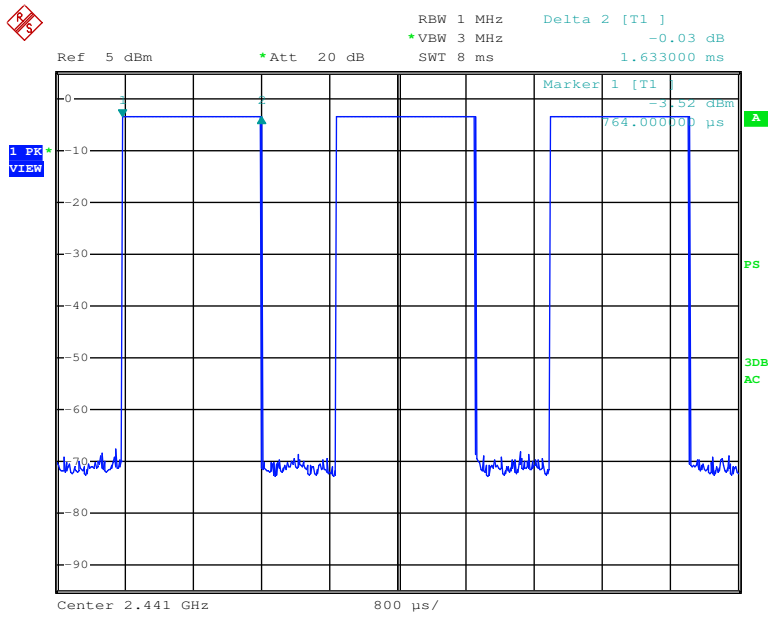

Date: 27.MAY.2016 11:51:46

DH3: High channel

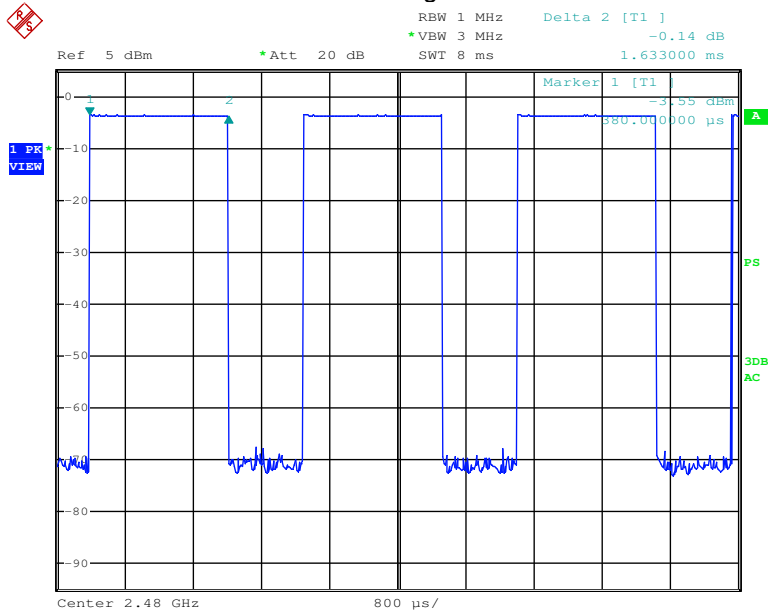

Date: 27.MAY.2016 11:52:10

DH5: Low channel

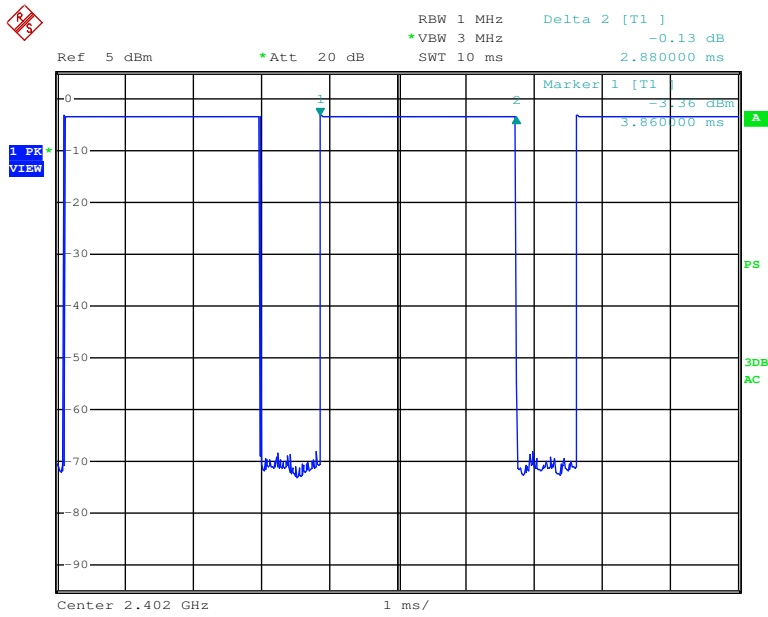

Date: 27.MAY.2016 11:54:00

DH5: Middle channel

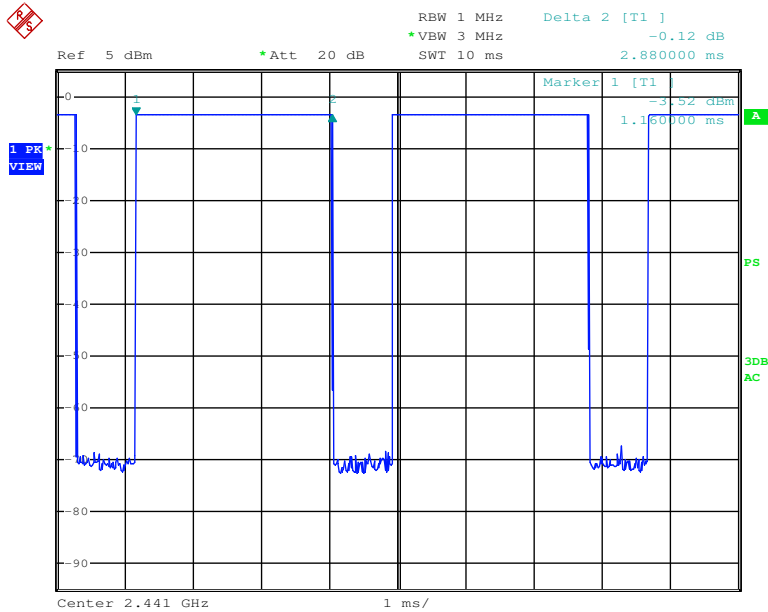

Date: 27.MAY.2016 11:53:31

DH5: High channel

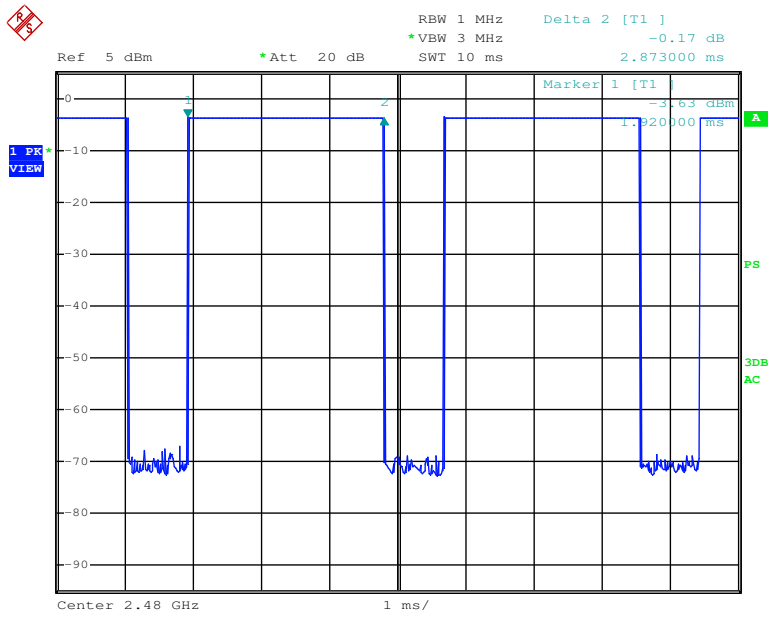

Date: 27.MAY.2016 11:52:38

2DH1: Low channel

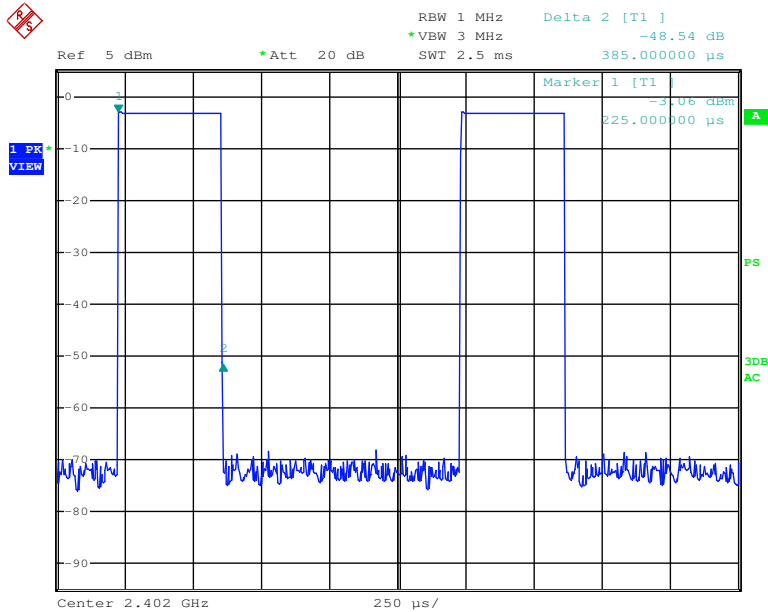

Date: 27.MAY.2016 11:48:50

2DH1: Middle channel

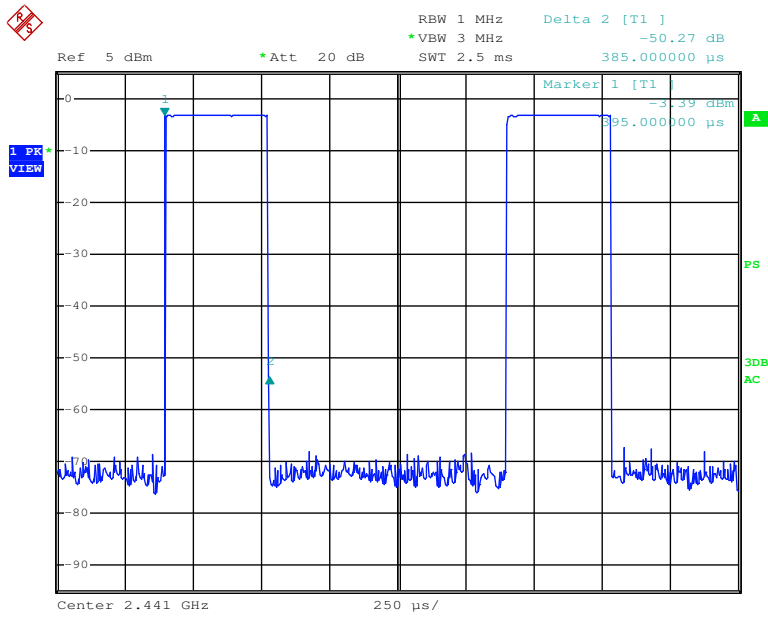

Date: 27.MAY.2016 11:49:22

2DH1: High channel

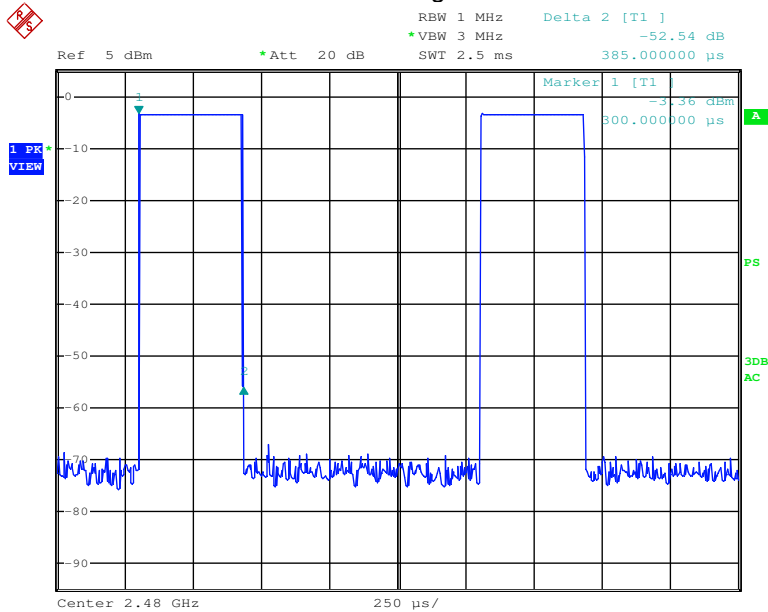

Date: 27.MAY.2016 11:49:48

2DH3: Low channel

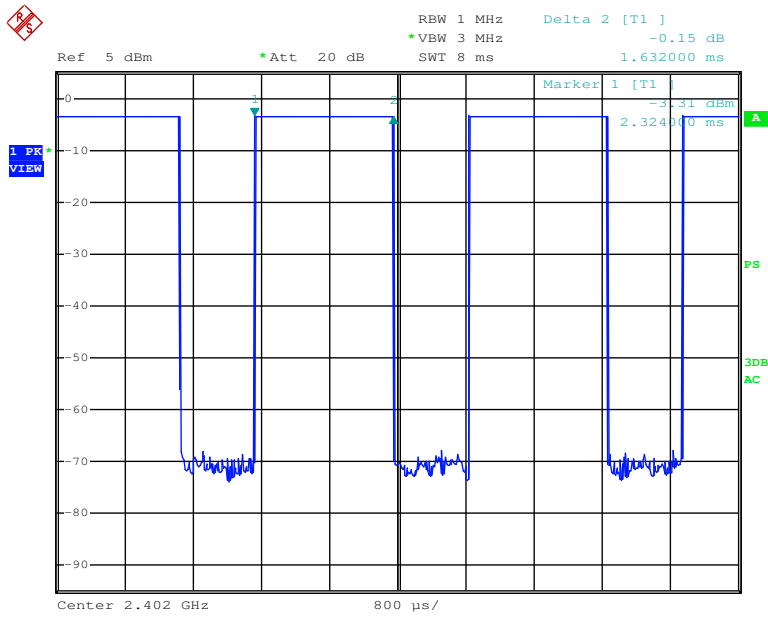

Date: 27.MAY.2016 11:54:34

2DH3: Middle channel

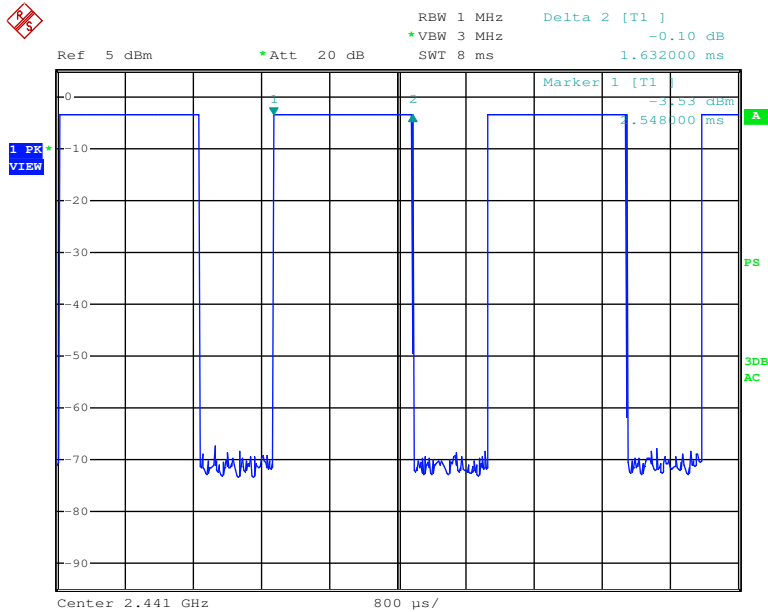

Date: 27.MAY.2016 11:55:00

2DH3: High channel

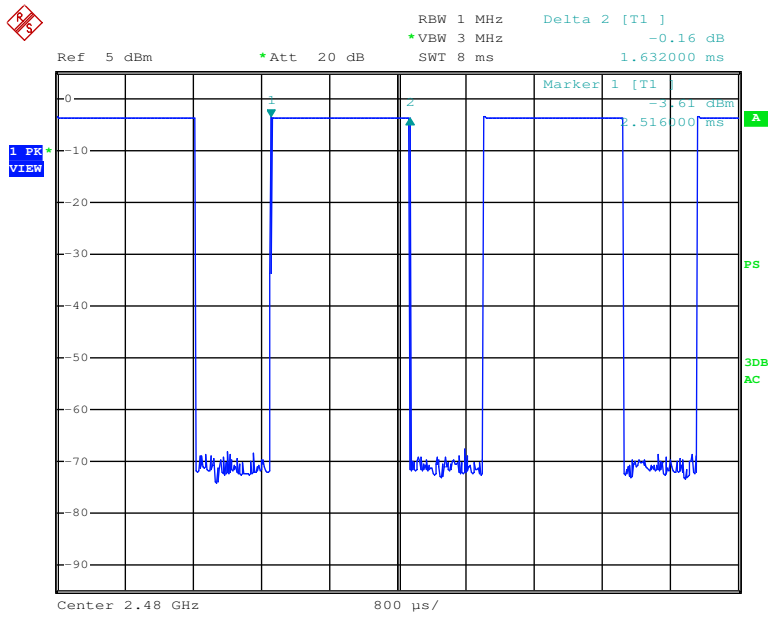

Date: 27.MAY.2016 11:55:24

2DH5: Low channel

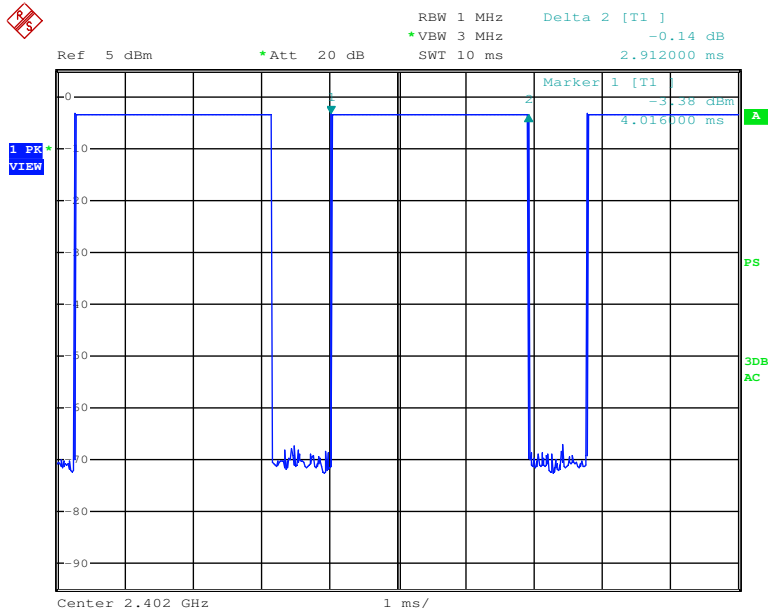

Date: 27.MAY.2016 11:56:37

2DH5: Middle channel

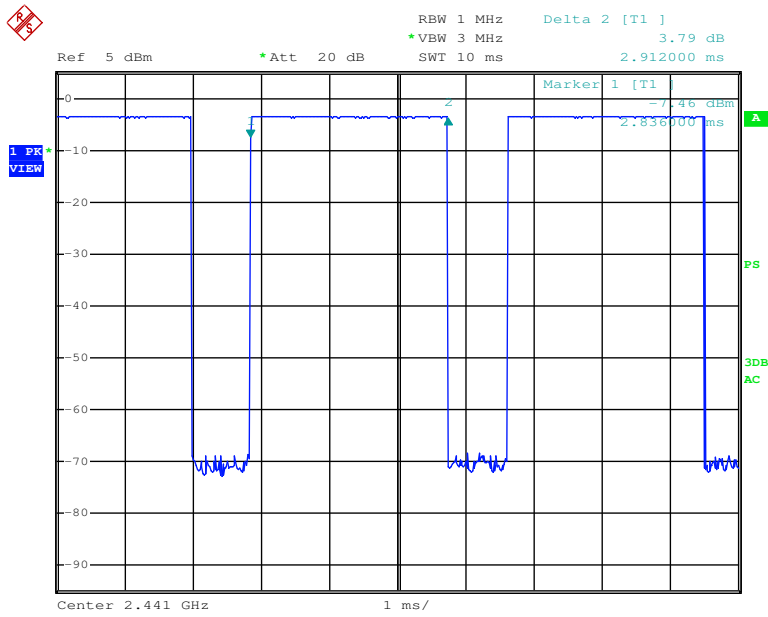

Date: 27.MAY.2016 11:56:14

2DH5: High channel

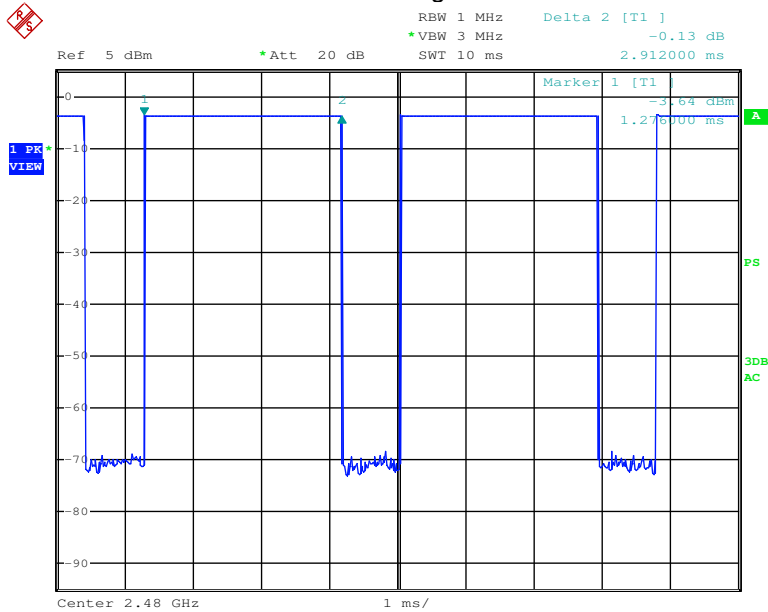

Date: 27.MAY.2016 11:55:46

10. Maximum Peak Output Power Test

10.1 Measurement Procedure

- a. Check the calibration of the measuring instrument(SA) using either an internal calibrator or a known signal from an external generator.
- b. Turn on the EUT and connect it to measurement instrument. Then set it to any one convenient frequency within its operating range. Set a reference level on the measuring instrument equal to the highest peak value.
- c. The center frequency of the spectrum analyzer is set to the fundamental frequency and using proper RBW and VBW setting.
- d. Measure the captured power within the band and recording the plot.
- e. Repeat above procedures until all frequencies required were complete.

10.2 Test SET-UP (Block Diagram of Configuration)

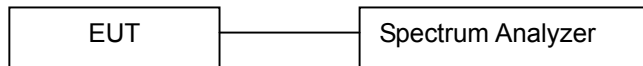

10.3 Measurement Equipment Used

Name of Equipment	Manufacturer	Model	Serial Number	Last Cal.	CAL DUE.
Spectrum Analyzer	Rohde & Schwarz	ESCI	101414	05/15/2016	05/14/2017

10.4 Measurement Results

Refer to attached data chart.

GFSK Mode: Middle channel

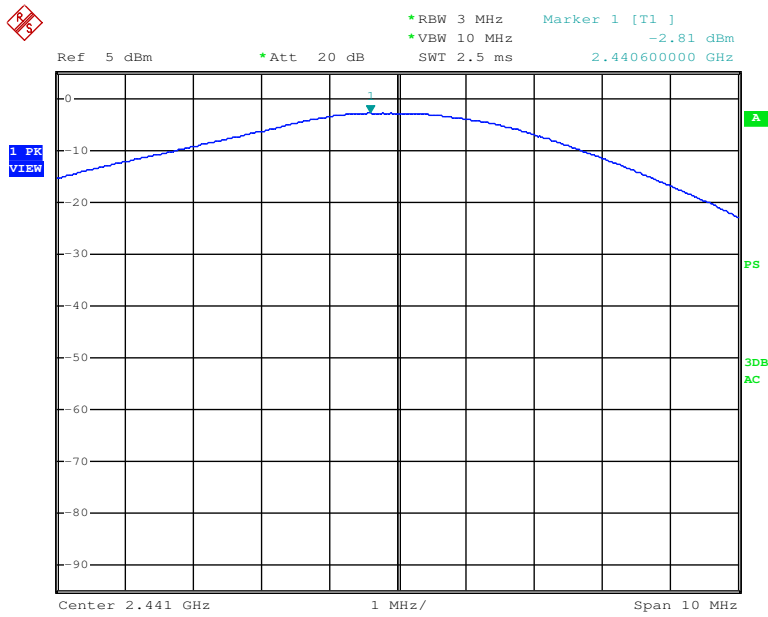

Date: 27.MAY.2016 11:23:18

GFSK Mode: High channel

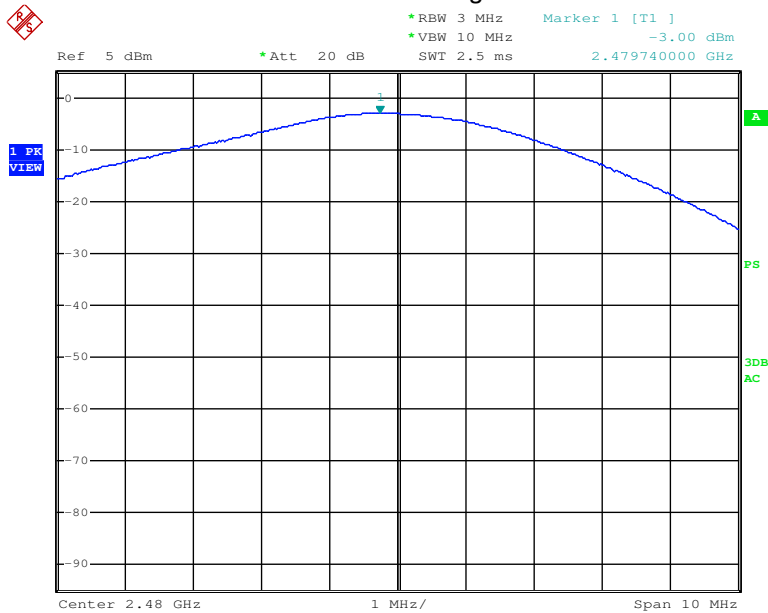

Date: 27.MAY.2016 11:23:45

$\pi/4$ -DQPSK Mode: Low channel

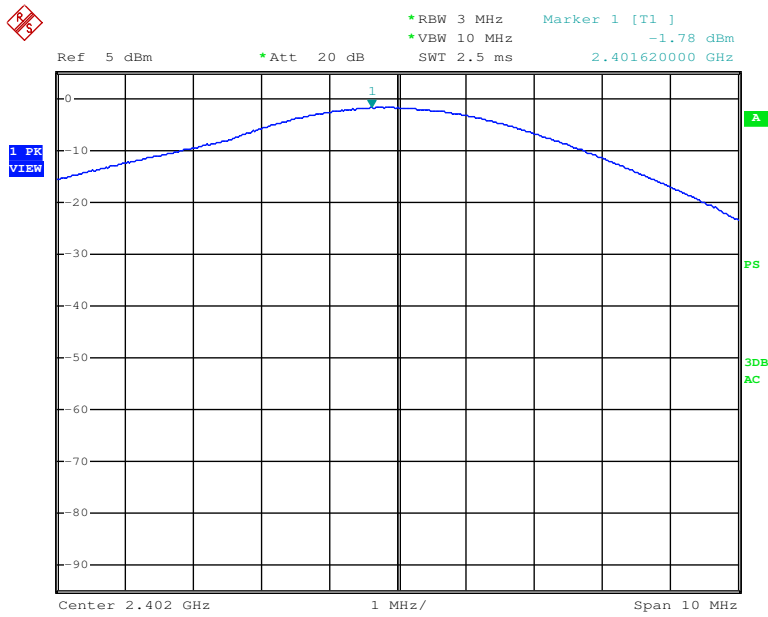

Date: 27.MAY.2016 11:24:43

$\pi/4$ -DQPSK Mode: Middle channel

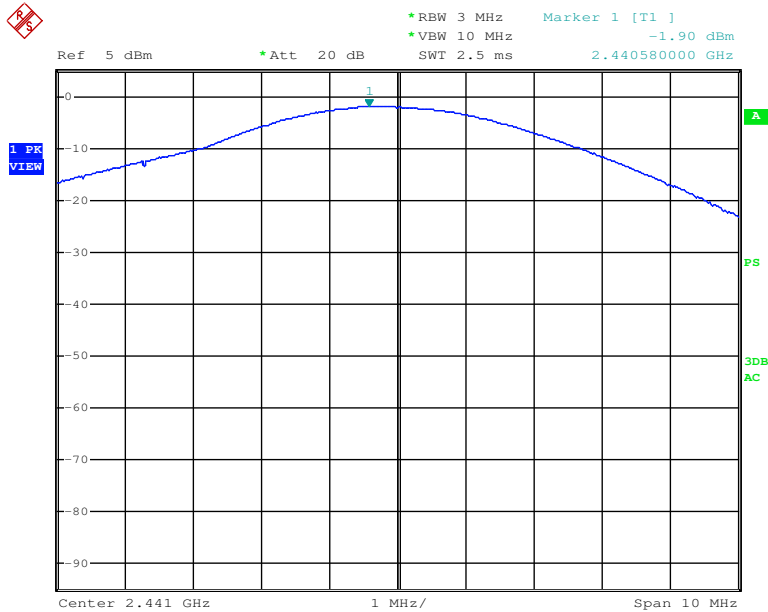

Date: 27.MAY.2016 11:25:12

$\pi/4$ -DQPSK Mode: High channel

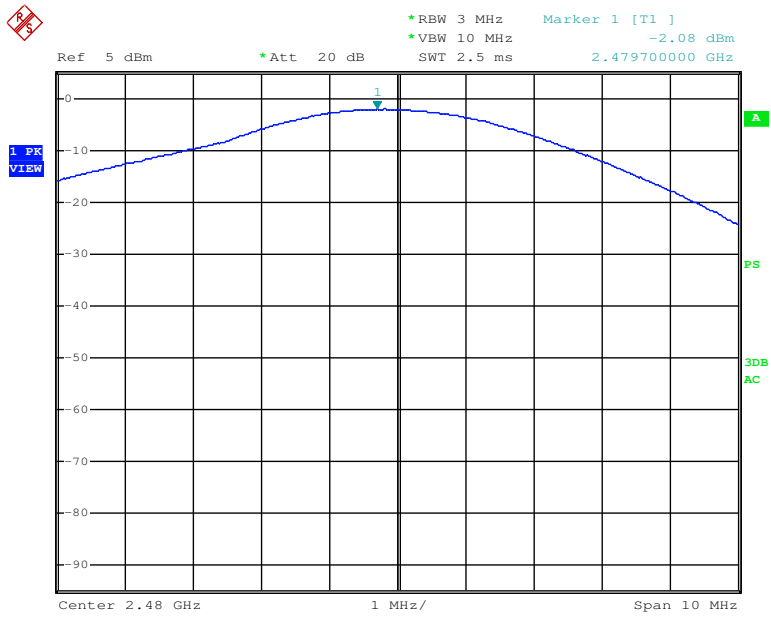

Date: 27.MAY.2016 11:25:58

11. Band Edge Test

11.1 Applicable Standard

In any 100 kHz bandwidth outside the frequency band in which the spread spectrum or digitally modulated intentional radiator is operating, the radio frequency power that is produced by the intentional radiator shall be at least 20 dB below that in the 100 kHz bandwidth within the band that contains the highest level of the desired power, based on either an RF conducted or a radiated measurement, provided the transmitter demonstrates compliance with the peak conducted power limits. If the transmitter complies with the conducted power limits based on the use of RMS averaging over a time interval, as permitted under paragraph (b)(3) of this section, the attenuation required under this paragraph shall be 30 dB instead of 20 dB. Attenuation below the general limits specified in §15.209(a) is not required. In addition, radiated emissions which fall in the restricted bands, as defined in §15.205(a), must also comply with the radiated emission limits specified in §15.209(a) (see §15.205(c)).

11.2 Measurement Procedure

(A) Conducted method:

Measurements were performed using a spectrum analyzer with a suitable span to encompass the peak of the fundamental and using the following settings: RBW = 100kHz, VBW = 300kHz.

(B) Radiated method:

1. The EUT was Operating in hopping mode or could be controlled its channel. Printed out test result from the spectrum by hard copy function.
2. The EUT was placed on a turn table which is 0.8m above ground plane.
3. Maximum procedure was performed on the six highest emissions to ensure EUT compliance.
4. And also, each emission was to be maximized by changing the polarization of receiving antenna both horizontal and vertical.
5. Repeat above procedures until all frequency measured were complete.
(Peak measurement: Peak detector, RBW=1MHz, VBW=3MHz, Sweep=Auto
Average measurement: Peak detector, RBW=1MHz, VBW=10Hz, Sweep=Auto)

11.3 Measurement Equipment Used

Conducted method: Same as 6.3 Channel Separation Measurement.

Radiated method: Same as 5.3 Radiated Emission Measurement.

11.4 Measurement Results

Pass

Refer to attached data chart.

(A) Conducted Measurement

For Hopping Mode:

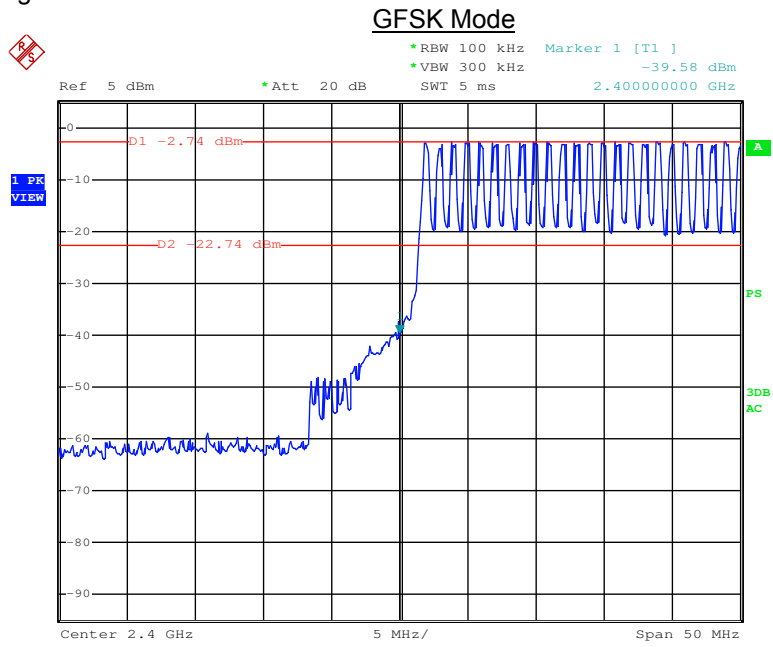

Date: 27.MAY.2016 12:12:45

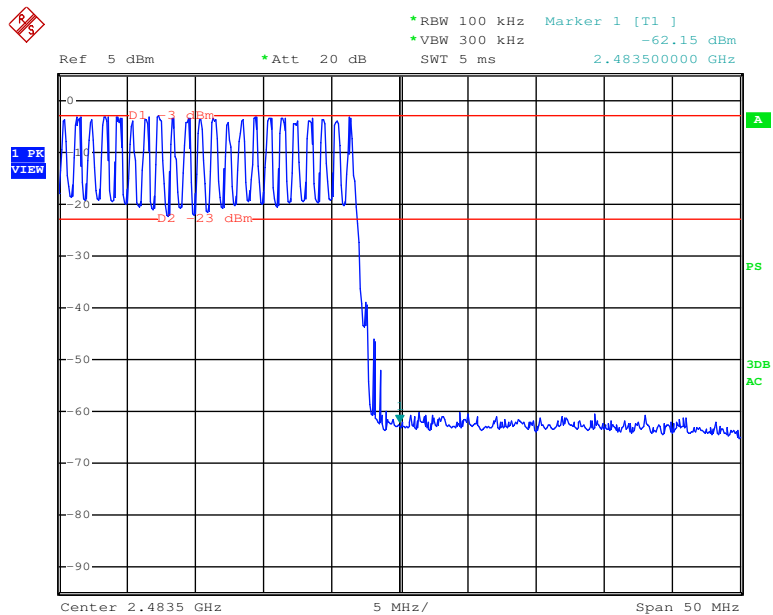

Date: 27.MAY.2016 12:14:42

$\pi/4$ -DQPSK Mode

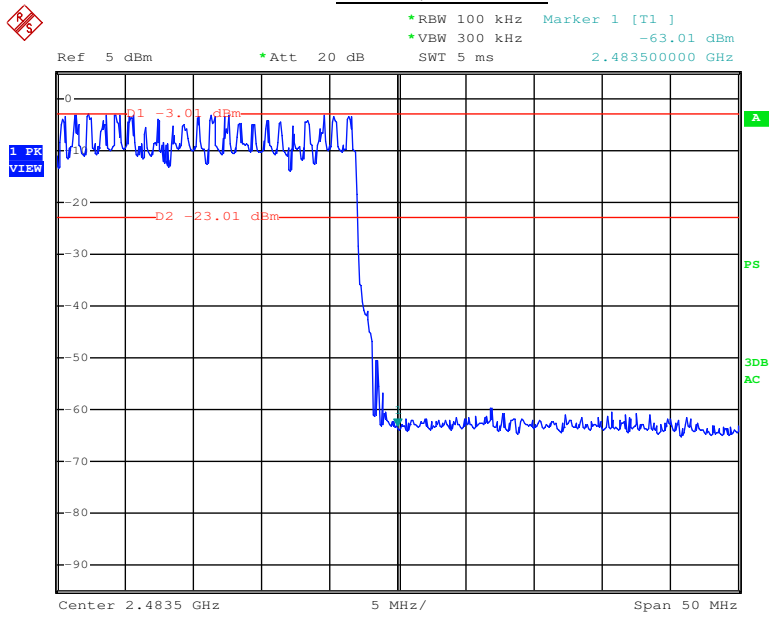

Date: 27.MAY.2016 12:16:15

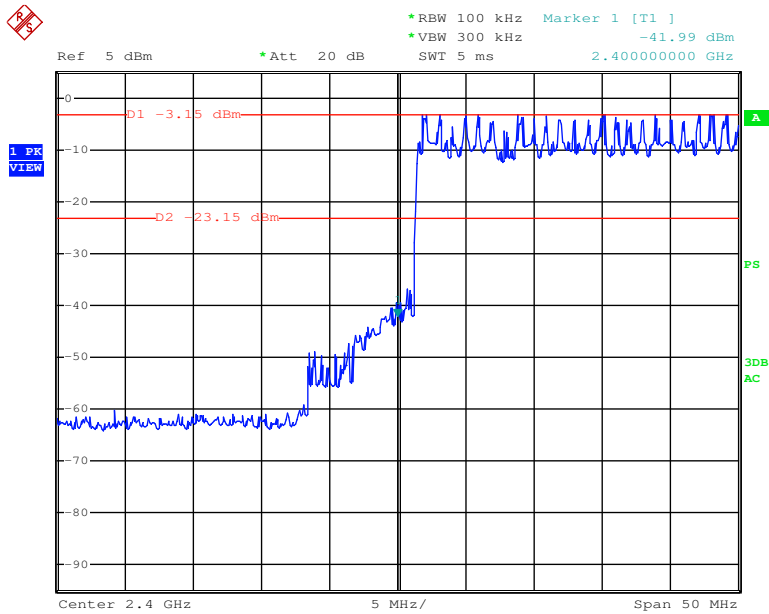

Date: 27.MAY.2016 12:18:05

$\pi/4$ -DQPSK Mode

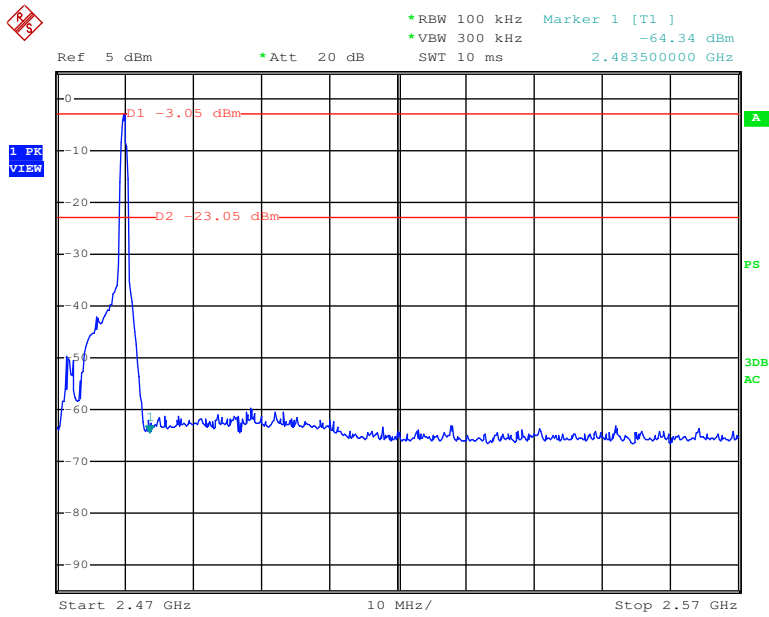

Date: 27.MAY.2016 12:06:17

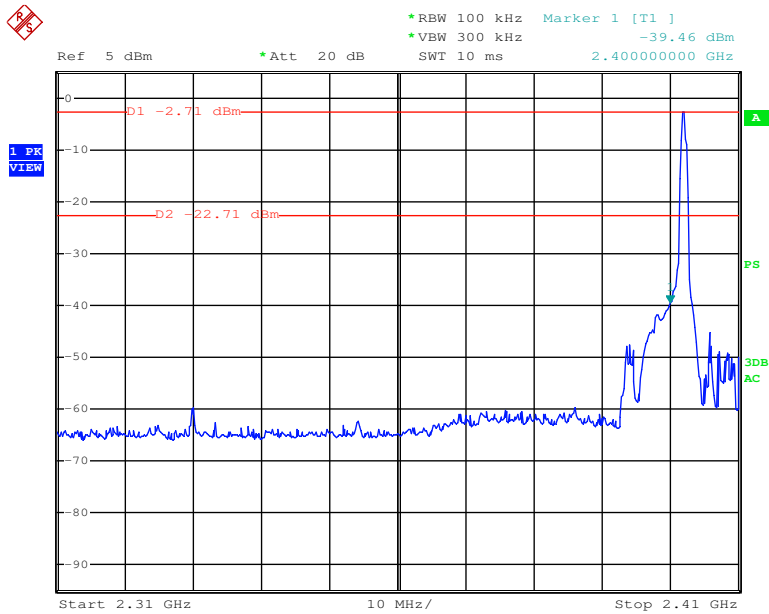

Date: 27.MAY.2016 12:07:45

(B) Radiated Measurement

For Hopping Mode:

GFSK Mode

Vertical:

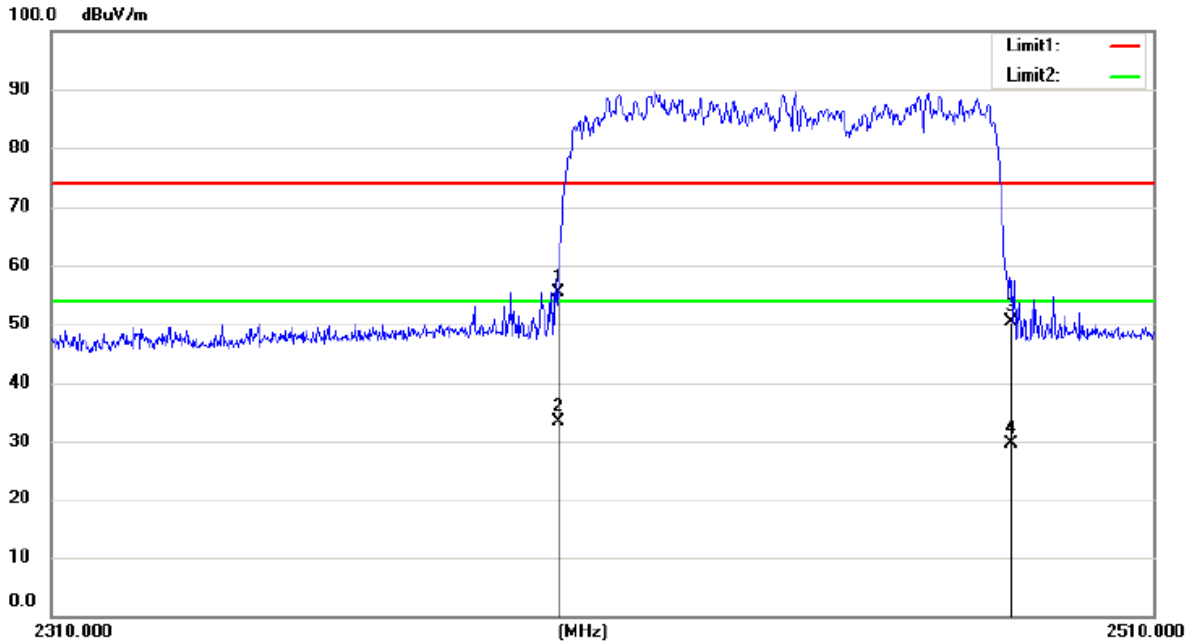

Site site #1 Polarization: *Vertical* Temperature: 20 C
 Limit: (RE)FCC Part15 Class B (1~6GHz)Peak Power: AC 120V/60Hz Humidity: 52 %
 EUT: COOLER SPEAKER
 M/N: M5
 Mode:GFSK
 Note:

No.	Mk.	Freq.	Reading Level	Correct Factor	Measurement	Limit	Over	Antenna Height	Table Degree	
		MHz	dBuV	dB	dBuV/m	dBuV/m	dB	cm	degree	Comment
1	*	2400.000	44.37	10.93	55.30	74.00	-18.70			peak
2		2400.000	22.57	10.93	33.50	54.00	-20.50			AVG
3		2483.500	39.47	11.00	50.47	74.00	-23.53			peak
4		2483.500	18.60	11.00	29.60	54.00	-24.40			AVG

Horizontal:

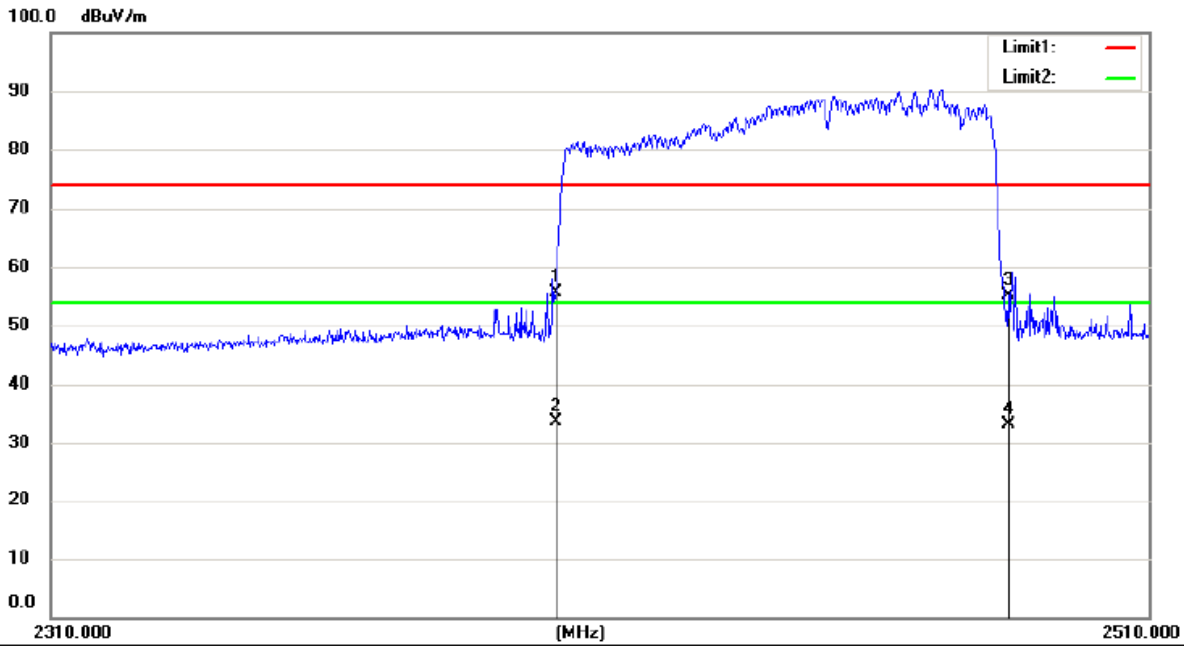

Site site #1 Polarization: **Horizontal** Temperature: 20 C
 Limit: (RE)FCC Part15 Class B (1~6GHz)Peak Power: AC 120V/60Hz Humidity: 52 %
 EUT: COOLER SPEAKER
 M/N: M5
 Mode:GFSK
 Note:

No.	Mk.	Freq.	Reading Level	Correct Factor	Measure-ment	Limit	Over	Antenna Height	Table Degree	
		MHz	dBuV	dB	dBuV/m	dBuV/m	dB	cm	degree	Comment
1	*	2400.000	44.60	10.93	55.53	74.00	-18.47			peak
2		2400.000	22.77	10.93	33.70	54.00	-20.30			AVG
3		2483.500	44.22	11.00	55.22	74.00	-18.78			peak
4		2483.500	22.20	11.00	33.20	54.00	-20.80			AVG

Vertical:

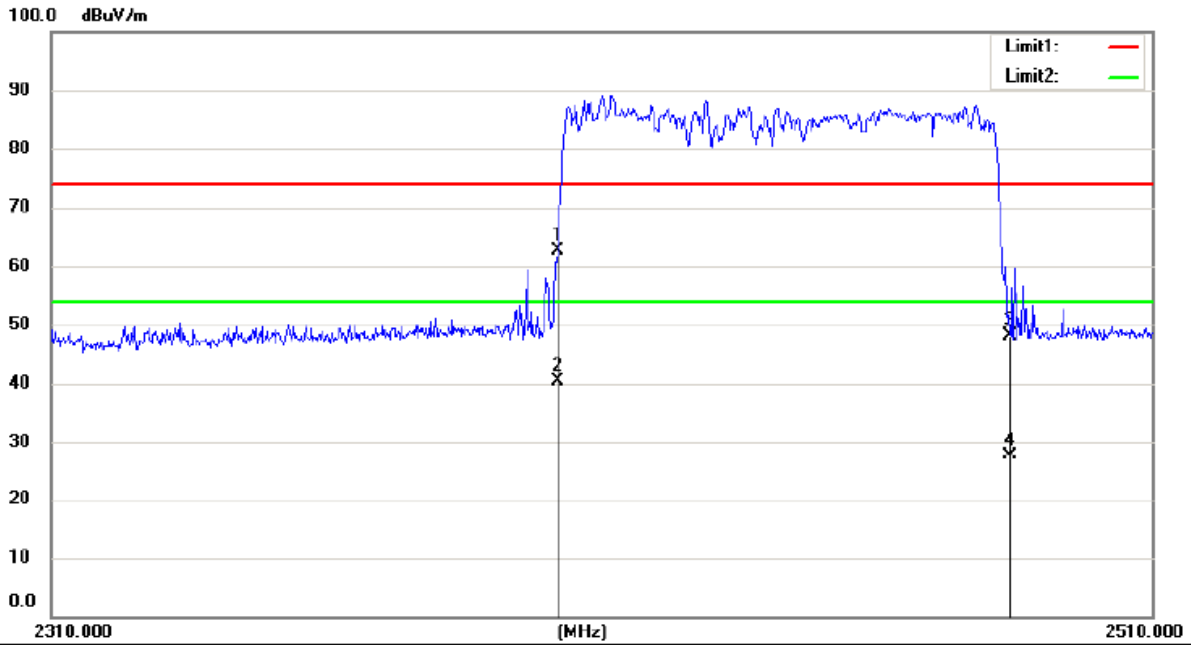

Site site #1 Polarization: **Vertical** Temperature: 20 C
 Limit: (RE)FCC Part15 Class B (1~6GHz)Peak Power: AC 120V/60Hz Humidity: 52 %
 EUT: COOLER SPEAKER
 M/N: M5
 Mode: $\pi/4$ DQPSK
 Note:

No.	Mk.	Freq.	Reading Level	Correct Factor	Measurement	Limit	Over	Antenna Height	Table Degree	
		MHz	dBuV	dB	dBuV/m	dBuV/m	dB	cm	degree	Comment
1	*	2400.000	51.73	10.93	62.66	74.00	-11.34			peak
2		2400.000	29.57	10.93	40.50	54.00	-13.50			AVG
3		2483.500	37.13	11.00	48.13	74.00	-25.87			peak
4		2483.500	16.60	11.00	27.60	54.00	-26.40			AVG

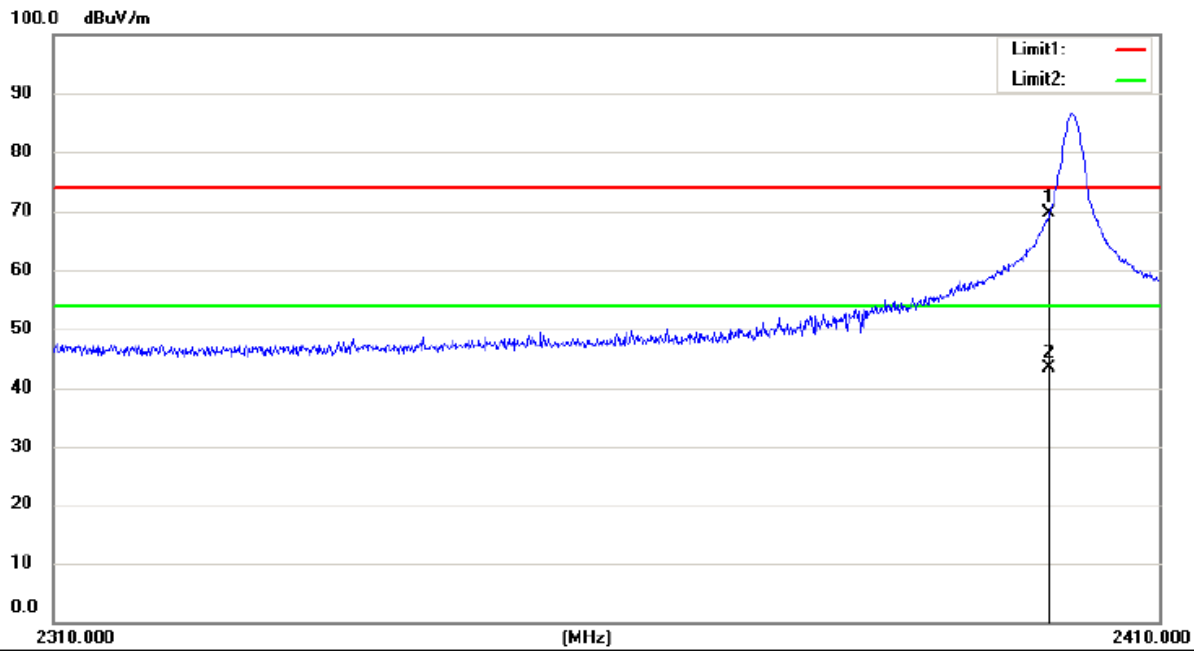

Site site #1 Polarization: *Horizontal* Temperature: 20 C
 Limit: (RE)FCC Part15 Class B (1~6GHz)Peak Power: AC 120V/60Hz Humidity: 52 %
 EUT: COOLER SPEAKER
 M/N: M5
 Mode:GFSK
 Note:

No.	Mk.	Freq.	Reading Level	Correct Factor	Measurement	Limit	Over	Antenna Height	Table Degree	
		MHz	dBuV	dB	dBuV/m	dBuV/m	dB	cm	degree	Comment
1	*	2400.000	58.79	10.93	69.72	74.00	-4.28			peak
2		2400.000	32.44	10.93	43.37	54.00	-10.63			AVG

High Channel (Vertical):

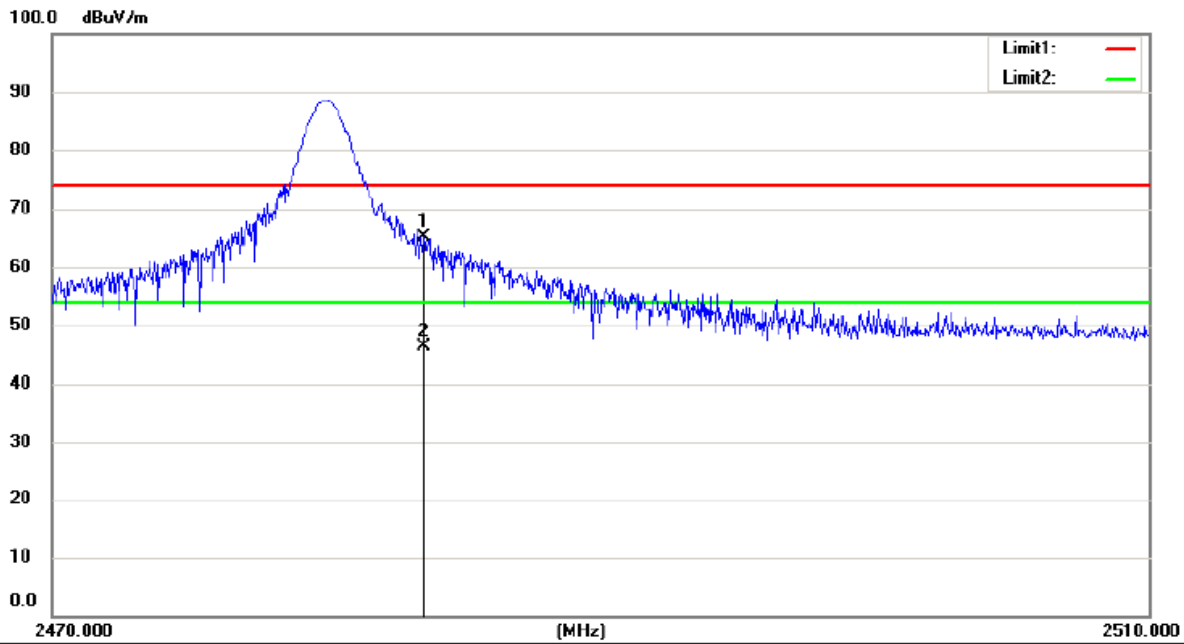

Site site #1 Polarization: *Vertical* Temperature: 20 C
 Limit: (RE)FCC Part15 Class B (1~6GHz)Peak Power: AC 120V/60Hz Humidity: 52 %
 EUT: COOLER SPEAKER
 M/N: M5
 Mode:GFSK
 Note:

No.	Mk.	Freq.	Reading Level	Correct Factor	Measurement	Limit	Over	Antenna Height	Table Degree	
		MHz	dBuV	dB	dBuV/m	dBuV/m	dB	cm	degree	Comment
1		2483.500	54.01	11.00	65.01	74.00	-8.99			peak
2	*	2483.500	35.30	11.00	46.30	54.00	-7.70			AVG

High Channel (Horizontal):

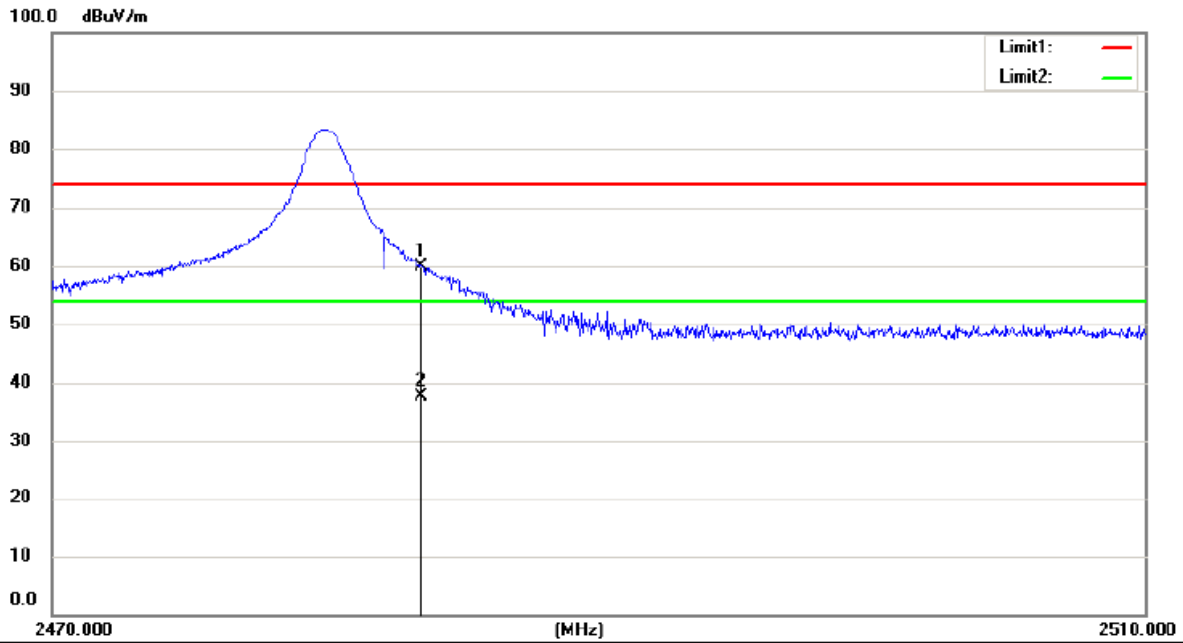

Site site #1 Polarization: **Horizontal** Temperature: 20 C
 Limit: (RE)FCC Part15 Class B (1~6GHz)Peak Power: AC 120V/60Hz Humidity: 52 %
 EUT: COOLER SPEAKER
 M/N: M5
 Mode:GFSK
 Note:

No.	Mk.	Freq.	Reading Level	Correct Factor	Measurement	Limit	Over	Antenna Height	Table Degree	
		MHz	dBuV	dB	dBuV/m	dBuV/m	dB	cm	degree	Comment
1	*	2483.500	48.81	11.00	59.81	74.00	-14.19			peak
2		2483.500	26.52	11.00	37.52	54.00	-16.48			AVG

$\pi/4$ -DQPSK Mode

Low Channel (Vertical):

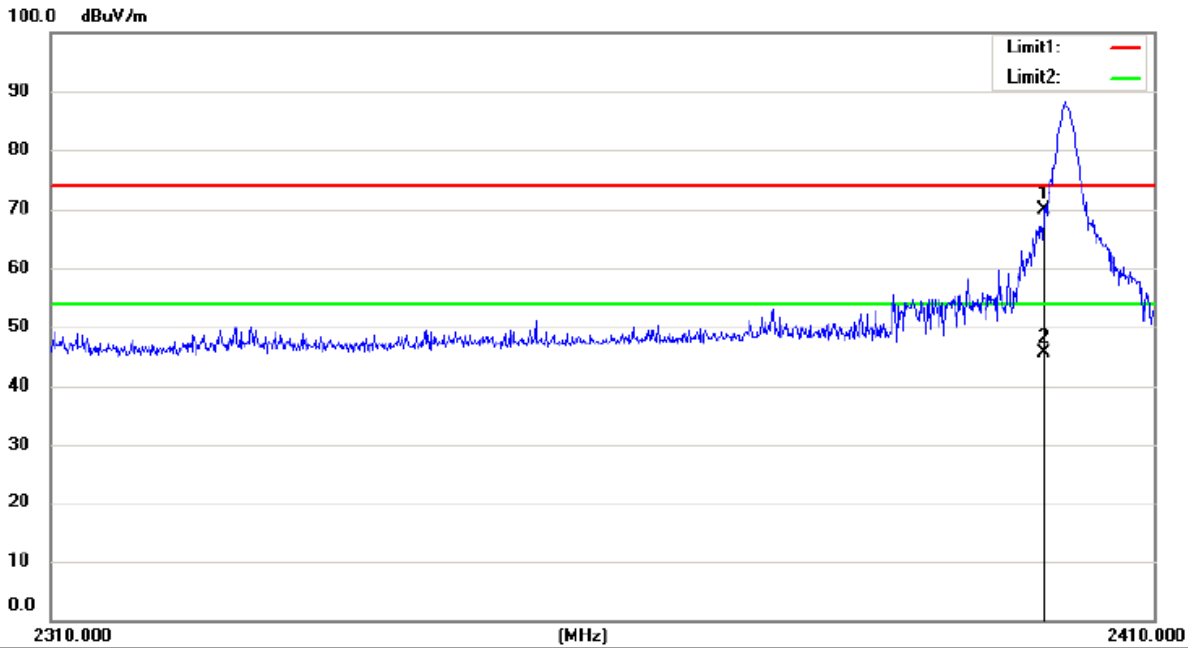

Site site #1 Polarization: *Vertical* Temperature: 20 C
 Limit: (RE)FCC Part15 Class B (1~6GHz)Peak Power: AC 120V/60Hz Humidity: 52 %
 EUT: COOLER SPEAKER
 M/N: M5
 Mode: $\pi/4$ DQPSK
 Note:

No.	Mk.	Freq.	Reading Level	Correct Factor	Measurement	Limit	Over	Antenna Height	Table Degree		
		MHz	dBuV	dB	dBuV/m	dBuV/m	dB	Detector	cm	degree	Comment
1	*	2400.000	58.86	10.93	69.79	74.00	-4.21	peak			
2		2400.000	34.67	10.93	45.60	54.00	-8.40	AVG			

Low Channel (Horizontal):

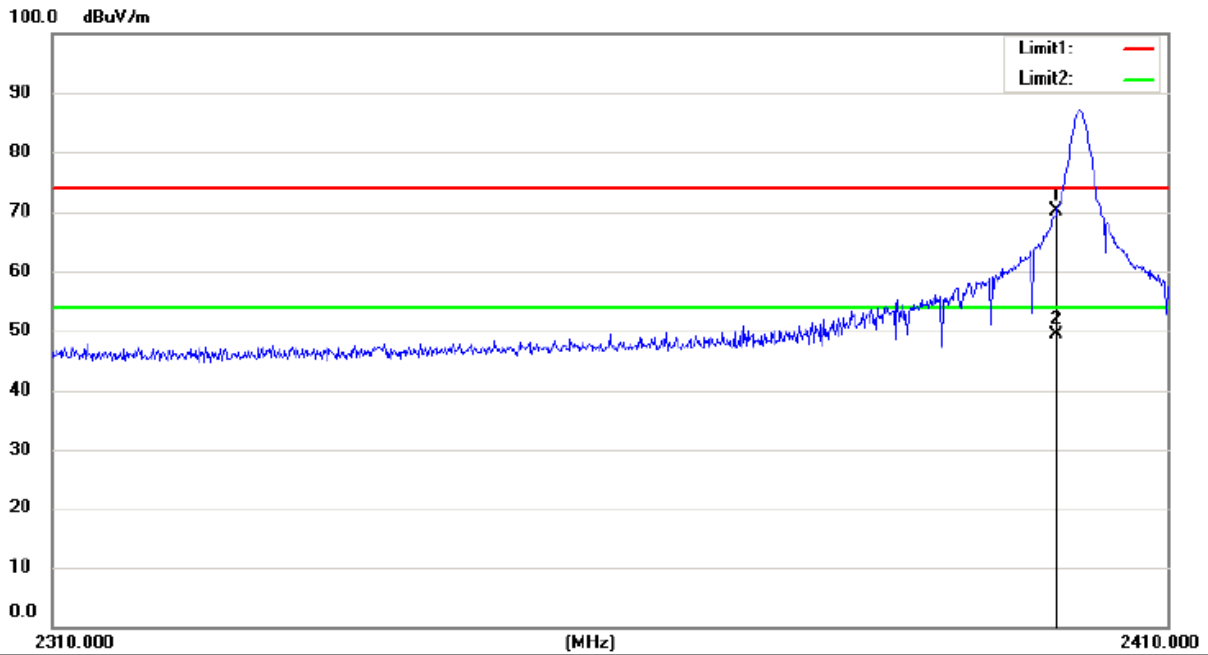

Site site #1 Polarization: *Horizontal* Temperature: 20 C
 Limit: (RE)FCC Part15 Class B (1~6GHz)Peak Power: AC 120V/60Hz Humidity: 52 %
 EUT: COOLER SPEAKER
 M/N: M5
 Mode: $\pi/4$ DQPSK
 Note:

No.	Mk.	Freq.	Reading Level	Correct Factor	Measurement	Limit	Over	Antenna Height	Table Degree	Comment
		MHz	dBuV	dB	dBuV/m	dBuV/m	dB	cm	degree	
1	*	2400.000	59.32	10.93	70.25	74.00	-3.75	peak		
2		2400.000	38.37	10.93	49.30	54.00	-4.70	AVG		

High Channel (Vertical):

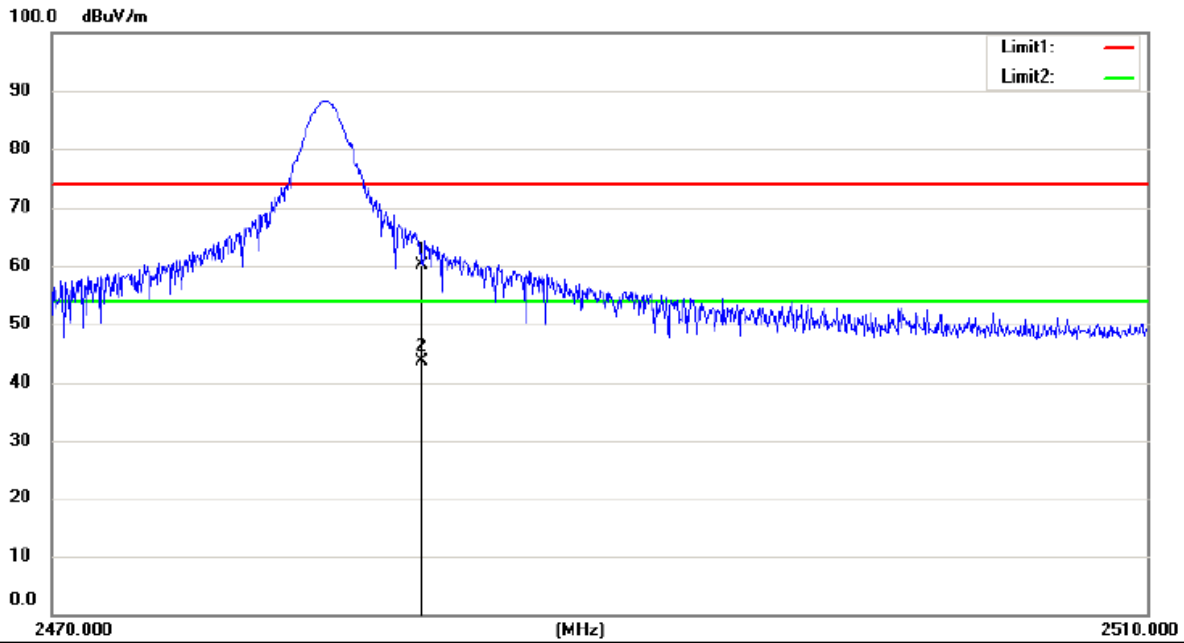

Site site #1 Polarization: **Vertical** Temperature: 20 C
 Limit: (RE)FCC Part15 Class B (1~6GHz)Peak Power: AC 120V/60Hz Humidity: 52 %
 EUT: COOLER SPEAKER
 M/N: M5
 Mode: $\pi/4$ DQPSK
 Note:

No.	Mk.	Freq.	Reading Level	Correct Factor	Measurement	Limit	Over	Antenna Height	Table Degree	
		MHz	dBuV	dB	dBuV/m	dBuV/m	dB	cm	degree	Comment
1		2483.500	49.14	11.00	60.14	74.00	-13.86			peak
2	*	2483.500	32.60	11.00	43.60	54.00	-10.40			AVG

High Channel (Horizontal):

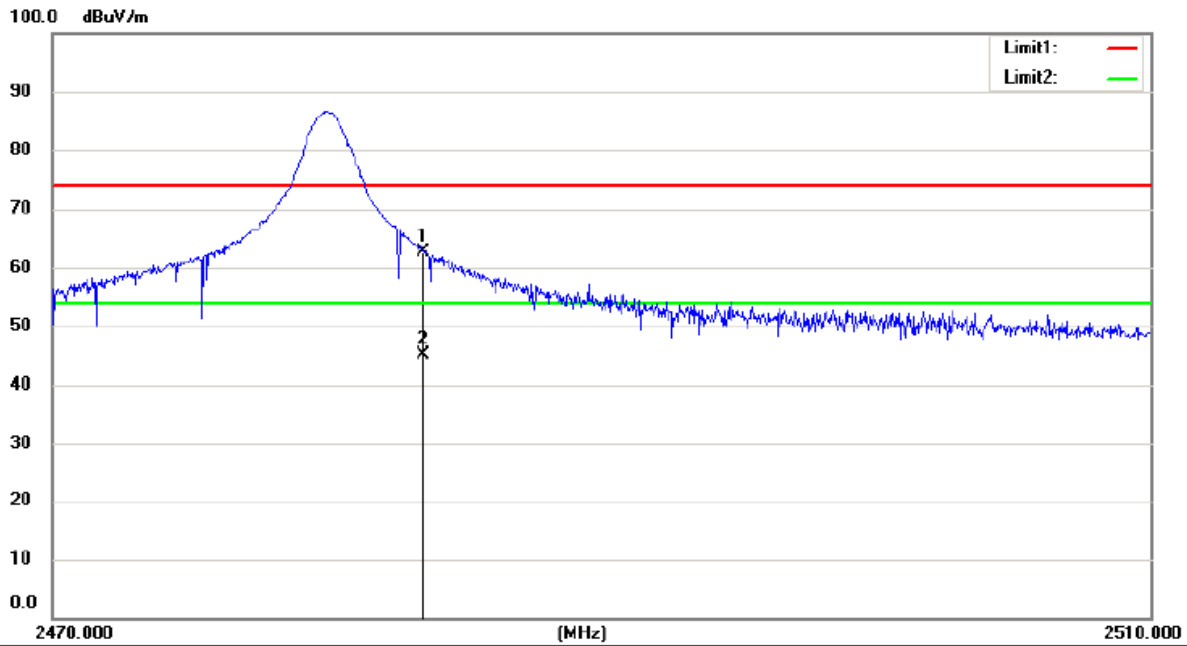

Site site #1 Polarization: *Horizontal* Temperature: 20 C
 Limit: (RE)FCC Part15 Class B (1~6GHz)Peak Power: AC 120V/60Hz Humidity: 52 %
 EUT: COOLER SPEAKER
 M/N: M5
 Mode: $\pi/4$ DQPSK
 Note:

No.	Mk.	Freq.	Reading Level	Correct Factor	Measurement	Limit	Over	Antenna Height	Table Degree	
		MHz	dBuV	dB	dBuV/m	dBuV/m	dB	cm	degree	Comment
1		2483.500	51.72	11.00	62.72	74.00	-11.28			peak
2	*	2483.500	34.10	11.00	45.10	54.00	-8.90			AVG

12. Antenna Port Emission

12.1 Test Equipment

Name of Equipment	Manufacturer	Model	Serial Number	Last Cal.	CAL DUE.
Spectrum Analyzer	Agilent	N9010A	My53470879	05/15/2016	05/14/2017

12.2 Measuring Instruments and setting

The following table is the setting of spectrum analyzer.

Attenuation	Auto
RB	100kHz
VB	300kHz
Detector	Peak
Trace	Max hold

12.3 Test Procedures

The conducted spurious emissions were measured conducted using a spectrum analyzer at low, mid, and hi channels, the limit was determined by attenuation 20dB of the RF peak power output.

12.4 Block Diagram of Test setup

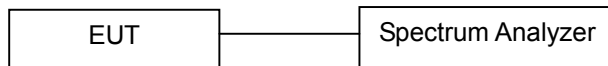

12.5 Test Result

PASS.

(Bluetooth (GFSK, pi/4-DQPSK) mode have been tested, and the worst result(GFSK) was report as below.)

GFSK Mode: Low channel

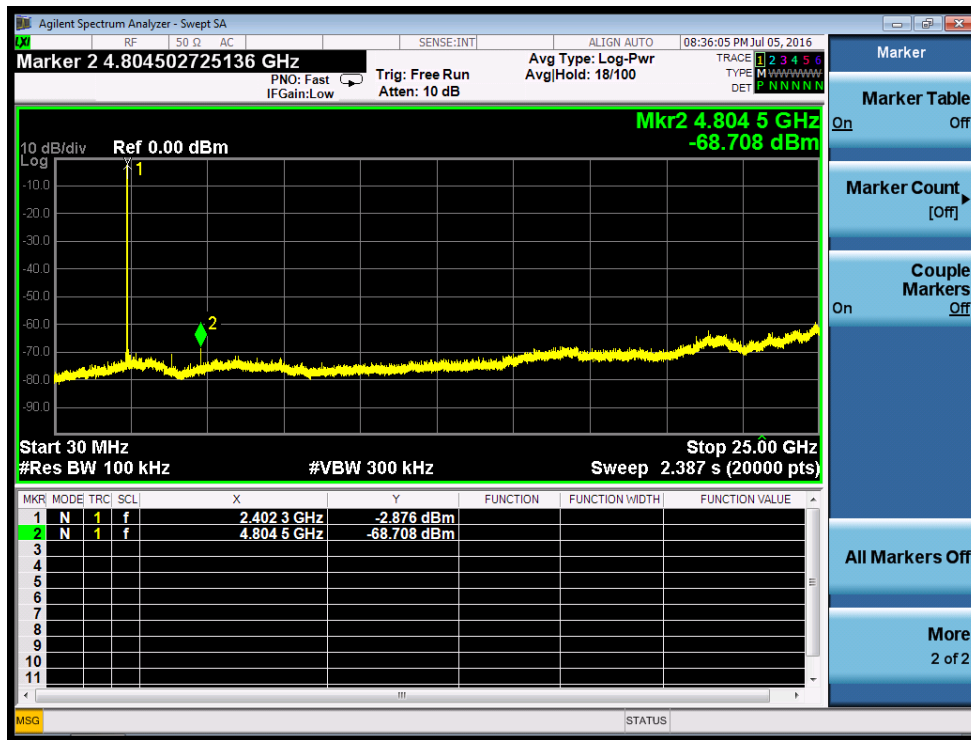

GFSK Mode: Middle channel

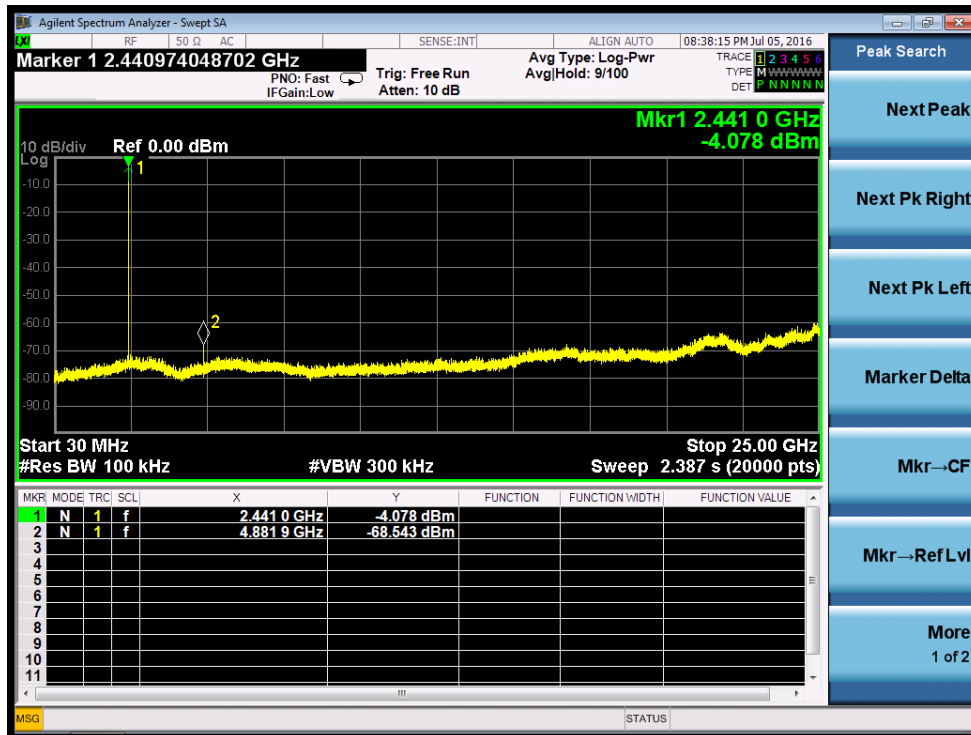

GFSK Mode: High channel

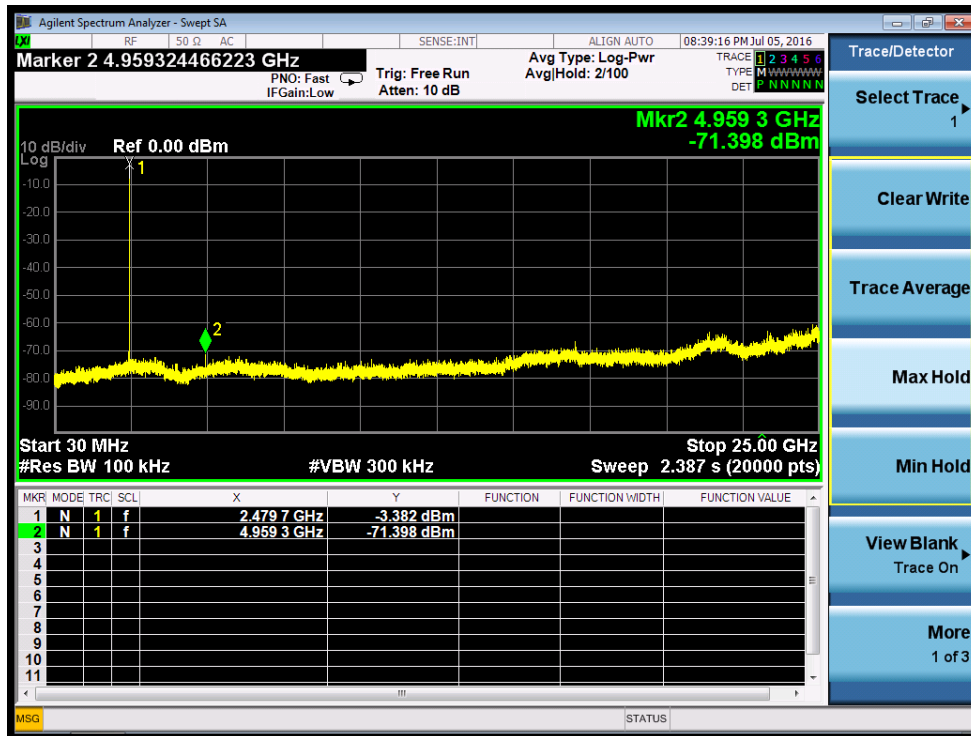

13. Antenna Application

13.1 Antenna requirement

The EUT'S antenna is met the requirement of FCC part 15C section 15.203 and 15.240.

FCC part 15C section 15.247 requirements:

Systems operating in the 2402-2480MHz band that are used exclusively for fixed, point-to-point operations may employ transmitting antennas with directional gain greater than 6dBi provided the maximum peak output power of the intentional radiator is reduced by 1dB for every 3dB that the directional gain of the antenna exceeds 6dBi.

13.2 Result

The EUT's antenna integrated on PCB, The antenna's gain is 0.68dBi and meets the requirement

---The End---