

TEST REPORT

Product Name : WIRELESS CHARGING VANITY MIRROR
Model Number : ENZ1000, TEM011
FCC ID : 2ACE5-ENZ1000

Prepared for : TELEPHONE EST (HK) CO., LTD
Address : Room709,7F, FuLi tianhe commercial building,Linhe East Road and tianhe district, Guangzhou, China

Prepared by : EMTEK (DONGGUAN) CO., LTD.
Address : -1&2/F.,Building 2, Zone A, Zhongda Marine Biotechnology Reserch and Development Base, No.9, Xincheng Avenue, Songshanhu High-technology Industrial Development Zone, Dongguan, Guangdong, China

TEL: +86-0769-22807078
FAX: +86-0769-22807079

Report Number : EDG2202210102E00101R
Date(s) of Tests : February 21, 2022 to March 17, 2022
Date of issue : March 17, 2022

TABLE OF CONTENT

Test Report Description	Page
1. SUMMARY OF TEST RESULTS.....	5
2. GENERAL INFORMATION.....	6
2.1. Description of Device (EUT).....	6
2.2. Input / Output Ports.....	6
2.3. Independent Operation Modes.....	7
2.4. Test Manner.....	7
2.5. Description of Test Facility.....	7
2.6. Test Software.....	7
2.7. Description of Support Device.....	8
2.8. Measurement Uncertainty.....	8
3. MEASURING DEVICE AND TEST EQUIPMENT.....	9
3.1. Conducted Emission Test Equipment.....	9
3.2. For 3m Radiated Emission Measurement 9K-30M (3m chamber 1#).....	9
3.3. For 3m Radiated Emission Measurement 30M-1G (3m chamber 1#).....	9
4. 20DB BANDWIDTH.....	10
4.1. Test Procedure.....	10
4.2. Test Results.....	10
5. POWER LINE CONDUCTED EMISSION MEASUREMENT.....	11
5.1. Block Diagram of Test Setup.....	11
5.2. Limits.....	11
5.3. Test Procedure.....	11
5.4. Measuring Results.....	12
6. RADIATED EMISSION TEST.....	15
6.1. Measurement Procedure.....	15
6.2. Test SET-UP (Block Diagram of Configuration).....	15
6.3. Measurement Equipment Used.....	16
6.4. Radiated Emission Limit.....	16
6.5. Measurement Result.....	18
7. ANTENNA REQUIREMENT.....	21

TEST REPORT DESCRIPTION

Applicant : TELEPHONE EST (HK) CO., LTD
 Address : Room709,7F, FuLi tianhe commercial building,Linhe East Road and tianhe district, Guangzhou, China
 Manufacturer : Telephone Est Electronics Factory(Zhong Shan)
 Address : NO.2 Shengfeng Heyuan Road, Xiaolan Town, ,Zhongshan , Guangdong,China
 EUT : WIRELESS CHARGING VANITY MIRROR
 Model Name : ENZ1000, TEM011
 Trademark : Energizer

Measurement Procedure Used:

APPLICABLE STANDARDS	
STANDARD	TEST RESULT
FCC 47 CFR Part 2, Subpart J FCC 47 CFR Part 15, Subpart C	PASS

The above equipment was tested by DONGGUAN EMTEK CO., LTD. The test data, data evaluation, test procedures, and equipment configurations shown in this report were made in accordance with the procedures given in ANSI C63.10 (2013) and the energy emitted by the sample EUT tested as described in this report is in compliance with conducted and radiated emission limits of FCC Rules Part 15C

The test results of this report relate only to the tested sample identified in this report.

Date of Test : February 21, 2022 to March 17, 2022

Prepared by : 
Xia Yang/Editor

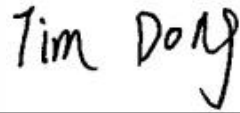
Reviewer : 
Tim Dong/Supervisor

Approve & Authorized Signer : 
Sam Lv/Manager



Modified Information

Version	Report No.	Revision Data	Summary
Ver.1.0	EDG2202210102E00101R	March 17, 2022	Original Version



1. SUMMARY OF TEST RESULTS

EMISSION		
Description of Test Item	Standard & Limits	Results
Conducted Emission	FCC Part 15, Subpart C- Section 15.207 ANSI C63.10-2013	Pass
Radiated Emission	FCC Part 15, Subpart C- Section 15.209 ANSI C63.10-2013	Pass
Note: N/A is an abbreviation for Not Applicable.		



2. GENERAL INFORMATION

2.1. Description of Device (EUT)

EUT	:	WIRELESS CHARGING VANITY MIRROR
Model Number	:	ENZ1000, TEM011 (These models are the same, except for the model names and color of the outercase; ENZ1000 was selected for full test.)
Input	:	DC 5.0V from USB
Operation Frequency for WPT	:	111-205kHz
Modulation	:	FSK
Antenna Type:	:	Induction Coil antenna
Date of Received	:	February 21, 2022
Temperature Range	:	0°C~+45°C
Date of Test	:	February 21, 2022 to March 17, 2022

2.2. Input / Output Ports

Port #	Name	Type*	Cable Max. >3m	Cable Shielded	Comments
1	Enclosure	N/E	--	--	None
2	DC IN port	I/O	No	Unshielded	1 port

* Note: For the purposes of the present document, the following symbols apply:

AC	AC Power Port
DC	DC Power Port
N/E	Non-Electrical
I/O	Signal Input or Output Port (Not Involved in Process Control)
TP	Telecommunication Ports

2.7. Description of Support Device

No.	Equipment	Trade name	Model	S/N	Power Cord
1.	Wireless Load	N/A	15w	N/A	N/A
2.	Adapter	Apple	A&A-050200U-US1	N/A	N/A

2.8. Measurement Uncertainty

Test Item	Uncertainty
Conducted Emission Uncertainty	3.16dB(9k~150kHz Conduction 2#) 2.90dB(150k-30MHz Conduction 2#)
Radiated Emission Uncertainty (3m Chamber)	3.78dB (30M~1GHz Polarize: H) 4.27dB (30M~1GHz Polarize: V) 4.46dB (1~6GHz)



3. MEASURING DEVICE AND TEST EQUIPMENT

3.1. Conducted Emission Test Equipment

EQUIPMENT TYPE	MFR	MODEL NUMBER	SERIAL NUMBER	LAST CAL.	DUE CAL.
Test Receiver	Rohde & Schwarz	ESCS30	828985/018	05/21/2021	05/20/2022
L.I.S.N.	Schwarzbeck	NNLK8129	8129203	05/21/2021	05/20/2022
50Ω Coaxial Switch	Anritsu	MP59B	M20531	05/21/2021	05/20/2022
Pulse Limiter	Rohde & Schwarz	ESH3-Z2	100006	05/21/2021	05/20/2022
Voltage Probe	Rohde & Schwarz	TK9416	N/A	05/21/2021	05/20/2022
I.S.N	Rohde & Schwarz	ENY22	1109.9508.02	05/21/2021	05/20/2022

3.2. For 3m Radiated Emission Measurement 9K-30M (3m chamber 1#)

Equipment	Manufacturer	Model No.	Serial No.	Last Cal.	DUE CAL.
EMI Test Receiver	Rohde & Schwarz	ESU	1302.6005.26	05/21/2021	05/20/2022
Loop Antenna	Schwarzbeck	FMZB 1519	1519-012	05/21/2021	05/20/2022
Cable		3M SF104-26.5	295838/4	05/21/2021	05/20/2022
Cable		6M SF104-26.5	295840/4	05/21/2021	05/20/2022

3.3. For 3m Radiated Emission Measurement 30M-1G (3m chamber 1#)

Equipment	Manufacturer	Model No.	Serial No.	Last Cal.	Cal. Interval
EMI Test Receiver	Rohde & Schwarz	ESU	1302.6005.26	05/21/2021	05/20/2022
Pre-Amplifier	HP	8447F	2944A07999	05/21/2021	05/20/2022
Bilog Antenna	Schwarzbeck	VULB9163	142	05/21/2021	05/20/2022
Cable	Schwarzbeck	AK9513	ACRX1	05/21/2021	05/20/2022
Cable	Rosenberger	N/A	FP2RX2	05/21/2021	05/20/2022
Cable	Schwarzbeck	AK9513	CRPX1	05/21/2021	05/20/2022
Cable	Schwarzbeck	AK9513	CRRX2	05/21/2021	05/20/2022

4. 20DB BANDWIDTH

4.1. Test Procedure

Set to the maximum power setting and enable the EUT transmit continuously
 Set RBW = 3Hz.
 Set the video bandwidth (VBW) =10kHz.
 Set Span= 1KHz
 Set Detector = Peak.
 Set Trace mode = max hold.
 Set Sweep = auto couple.
 Measure and record the results in the test report.

4.2. Test Results

Temperature: 24°C Test Date: 02/22/2022
 Humidity: 53 % Test By: Xia

20dB Band=30.97 KHz

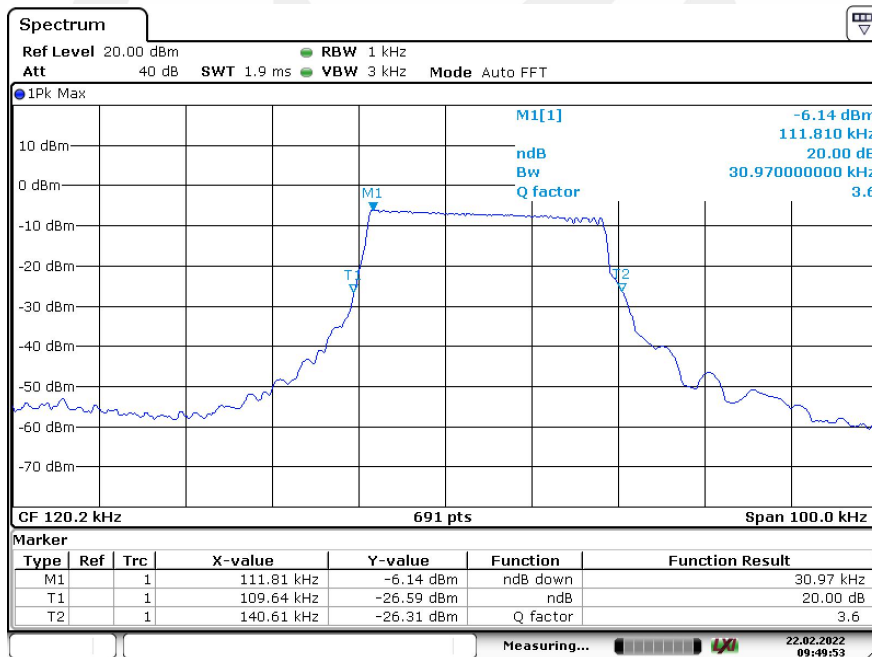

5. POWER LINE CONDUCTED EMISSION MEASUREMENT

5.1. Block Diagram of Test Setup

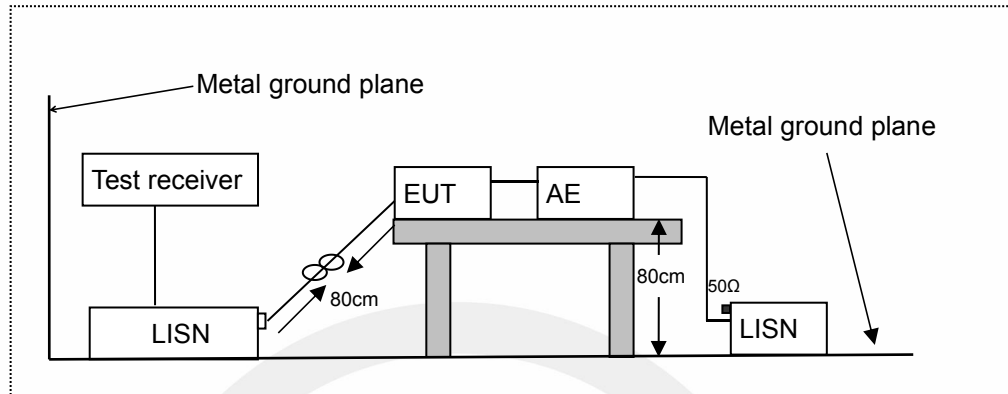

LISN: Line Impedance Stabilization Network
 AE: Associated equipment
 EUT: Equipment under test

5.2. Limits

FCC Part 15.207

Frequency (MHz)	Limit (dB μ V)	
	Quasi-peak Level	Average Level
0.15 ~ 0.50	66.0 ~ 56.0 *	56.0 ~ 46.0 *
0.50 ~ 5.00	56.0	46.0
5.00 ~ 30.00	60.0	50.0

NOTE1-The lower limit shall apply at the transition frequencies.
 NOTE2-The limit decreases linearly with the logarithm of the frequency in the range 0.15MHz to 0.50MHz.

5.3. Test Procedure

The EUT was placed on a desk 0.8 m height from the metal ground plane and 0.4 m from the conducting wall of the shielding room and it was kept at least 0.8 m from any other grounded conducting surface. The size of the table will nominally be 1.5 m x1.0 m.

The rear of the arrangement shall be flush with the back of the supporting tabletop unless that would not be possible or typical of normal use.

All units of equipment forming the system under test (includes the EUT as well as connected peripherals and associated equipment or devices) shall be arranged such that a nominal 0.1 m separation is achieved between the neighboring units.

Connect EUT to the power mains through a line impedance stabilization network (LISN). Where the mains cable supplied by the manufacturer is longer than 1 m, the excess should be folded at the centre into a bundle no longer than 0.4 m, so that its length is shortened to 1 m.

All the support units are connecting to the other LISN.

The LISN provides 50 ohm coupling impedance for the measuring instrument.

Both sides of AC line were checked for maximum conducted interference.

The frequency range from 150 kHz to 30 MHz was sweep.

Set the test-receiver system to quasi peak detect function and average detect function, and to measure the conducted emissions values.

Test results were obtained from the following equation:

Emission Level (dB μ V) = LISN Factor (dB) + Cable Loss (dB) + Reading (dB μ V)

Margin (dB) = Emission Level (dB μ V) - Limit (dB μ V)

5.4. Measuring Results

PASS.



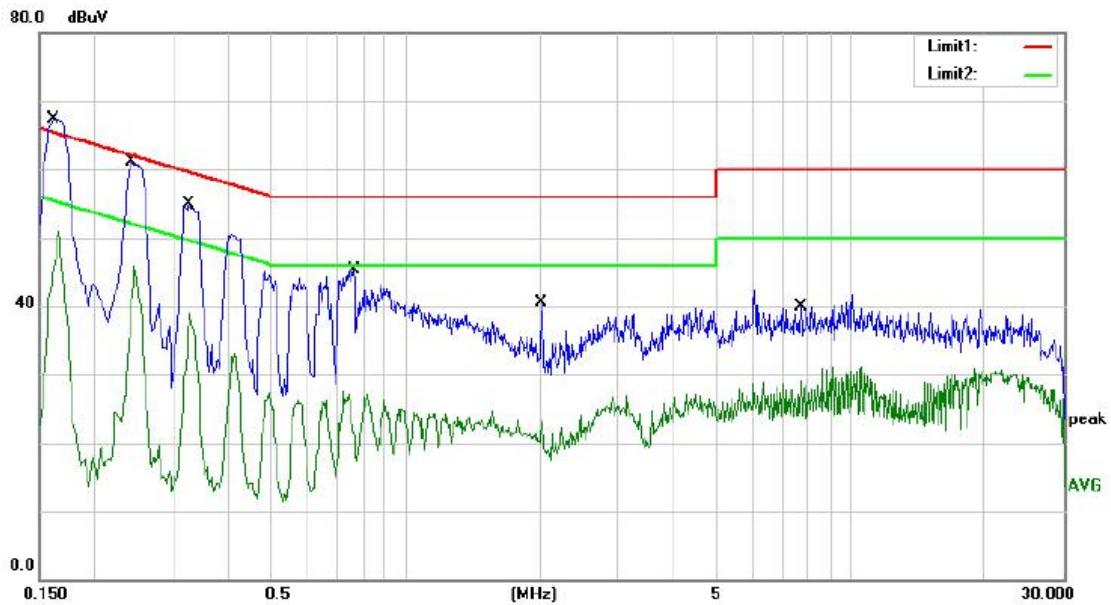

Site: site #1 Phase: **N** Temperature: 22.8
 Limit: (CE)FCC PART 15 C_QP Power: AC 120V/60Hz Humidity: 44 %
 Mode: Wireless Charging(10W)
 Note:

No.	Mk.	Freq. MHz	Reading Level dBuV	Correct Factor dB	Measure- ment dBuV	Limit dBuV	Over dB	Detector	Comment
1		0.1620	42.80	10.52	53.32	65.36	-12.04	QP	
2	*	0.1620	40.45	10.52	50.97	55.36	-4.39	AVG	
3		0.2420	44.57	10.43	55.00	62.03	-7.03	QP	
4		0.2420	35.49	10.43	45.92	52.03	-6.11	AVG	
5		0.3260	44.59	10.33	54.92	59.55	-4.63	QP	
6		0.3260	28.86	10.33	39.19	49.55	-10.36	AVG	
7		0.7660	35.19	10.13	45.32	56.00	-10.68	QP	
8		0.7660	23.00	10.13	33.13	46.00	-12.87	AVG	
9		2.0180	30.50	10.10	40.60	56.00	-15.40	QP	
10		2.0180	16.95	10.10	27.05	46.00	-18.95	AVG	
11		7.7180	29.94	10.05	39.99	60.00	-20.01	QP	
12		7.7180	21.14	10.05	31.19	50.00	-18.81	AVG	

*:Maximum data x:Over limit !:over margin Comment: Factor build in receiver. Operator:

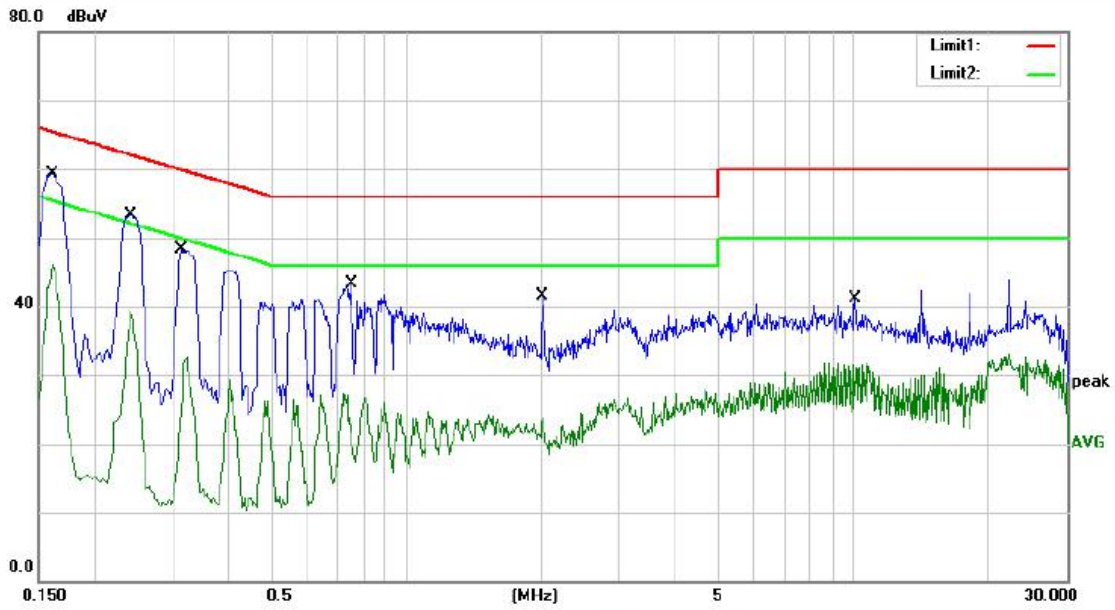

Site site #1 Phase: **L1** Temperature: 22.8
 Limit: (CE)FCC PART 15 C_QP Power: AC 120V/60Hz Humidity: 44 %
 Mode: Wireless Charging(10W)
 Note:

No.	Mk.	Freq. MHz	Reading Level dBuV	Correct Factor dB	Measure- ment dBuV	Limit dBuV	Over dB	Detector	Comment
1	*	0.1620	48.78	10.52	59.30	65.36	-6.06	QP	
2		0.1620	35.68	10.52	46.20	55.36	-9.16	AVG	
3		0.2420	42.92	10.43	53.35	62.03	-8.68	QP	
4		0.2420	28.87	10.43	39.30	52.03	-12.73	AVG	
5		0.3140	38.02	10.34	48.36	59.86	-11.50	QP	
6		0.3140	22.45	10.34	32.79	49.86	-17.07	AVG	
7		0.7540	33.12	10.13	43.25	56.00	-12.75	QP	
8		0.7540	17.21	10.13	27.34	46.00	-18.66	AVG	
9		2.0220	31.40	10.10	41.50	56.00	-14.50	QP	
10		2.0220	21.64	10.10	31.74	46.00	-14.26	AVG	
11		10.0740	31.08	10.04	41.12	60.00	-18.88	QP	
12		10.0740	23.07	10.04	33.11	50.00	-16.89	AVG	

*:Maximum data x:Over limit !:over margin Comment: Factor build in receiver. Operator:

6. RADIATED EMISSION TEST

6.1. Measurement Procedure

1. The EUT was placed on a turn table which is 0.8m above ground plane.
2. Maximum procedure was performed on the six highest emissions to ensure EUT compliance.
3. And also, each emission was to be maximized by changing the polarization of receiving antenna both horizontal and vertical.
4. Repeat above procedures until all frequency measured were complete.
5. Use the following receiver/spectrum analyzer settings:
 Span = wide enough to fully capture the emission being measured
 RBW=200Hz for 9KHz to 150KHz,
 RBW=9kHz for 150KHz to 30MHz,
 RBW=120KHz for 30MHz to 1GHz
 VBW $\geq 3 \times$ RBW
 Sweep = auto
 Detector function = QP
 Trace = max hold

6.2. Test SET-UP (Block Diagram of Configuration)

(A) Radiated Emission Test Set-Up, Frequency Below 30MHz

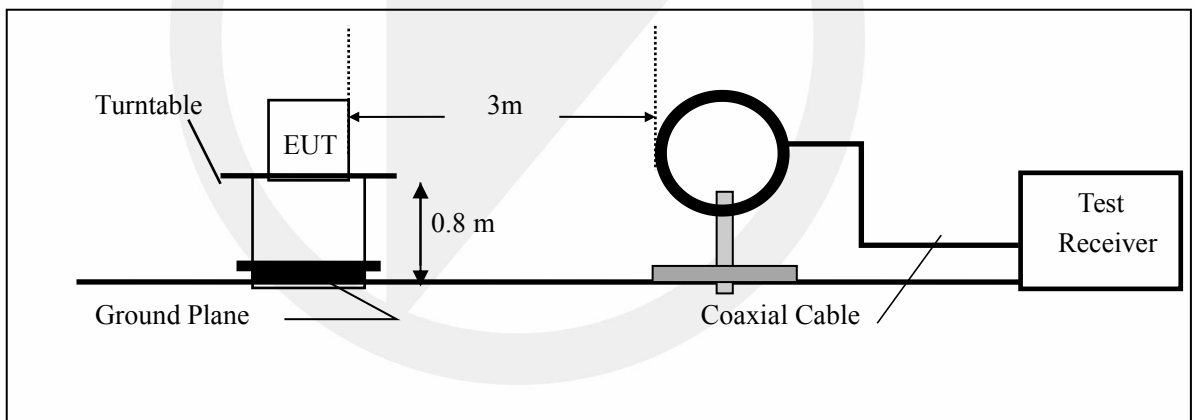

(B) Radiated Emission Test Set-Up, Frequency Below 1000MHz

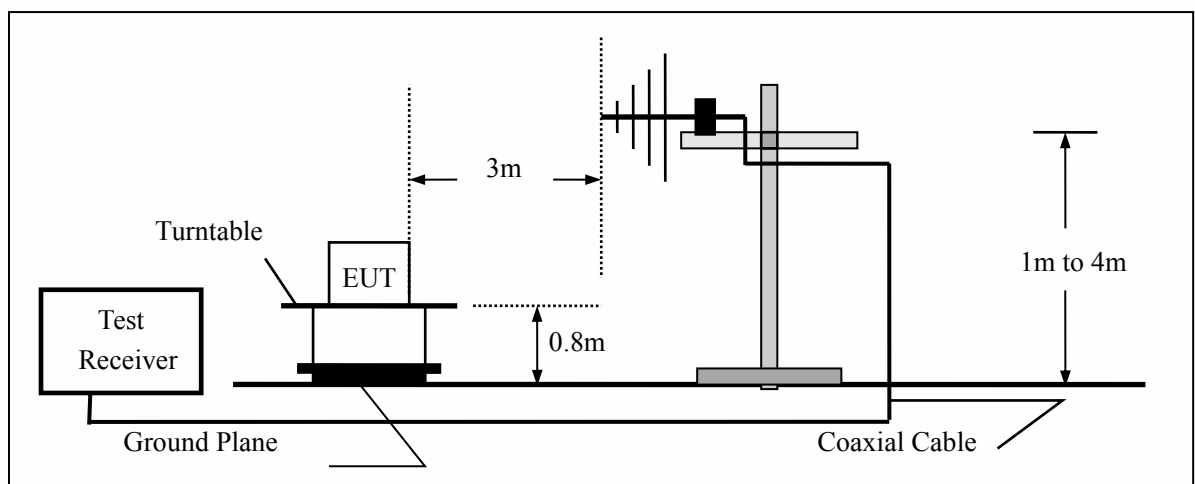

6.3.Measurement Equipment Used

EQUIPMENT TYPE	MFR	MODEL NUMBER	SERIAL NUMBER	LAST CAL.	CAL DUE.
EMI Test Receiver	Rohde & Schwarz	ESU	1302.6005.26	05/21/2021	05/20/2022
Pre-Amplifier	HP	8447D	2944A07999	05/21/2021	05/20/2022
Bilog Antenna	Schwarzbeck	VULB9163	142	05/21/2021	05/20/2022
Loop Antenna	ARA	PLA-1030/B	1029	05/21/2021	05/20/2022
Horn Antenna	Schwarzbeck	BBHA 9170	BBHA9170399	05/21/2021	05/20/2022
Horn Antenna	Schwarzbeck	BBHA 9120	D143	05/21/2021	05/20/2022
Cable	Schwarzbeck	AK9513	ACRX1	05/21/2021	05/20/2022
Cable	Rosenberger	N/A	FP2RX2	05/21/2021	05/20/2022
Cable	Schwarzbeck	AK9513	CRPX1	05/21/2021	05/20/2022
Cable	Schwarzbeck	AK9513	CRRX2	05/21/2021	05/20/2022

6.4.Radiated Emission Limit

The emissions from an intentional radiator shall not exceed the field strength levels specified in the following table 15.209(a):

FCC Part 15.209				
Frequency (MHz)	Field Strength Limitation		Field Strength Limitation Frequency tion at 3m Measurement Dist	
	(uV/m)	Dist	(uV/m)	(dBuV/m)
0.009 – 0.490	2400 / F(KHz)	300m	10000 * 2400/F(KHz)	20log 2400/F(KHz) + 80
0.490 – 1.705	24000 / F(KHz)	30m	100 * 24000/F(KHz)	20log 24000/F(KHz) + 40
1.705 – 30.00	30	30m	100* 30	20log 30 + 40
30.0 – 88.0	100	3m	100	20log 100
88.0 – 216.0	150	3m	150	20log 150
216.0 – 960.0	200	3m	200	20log 200
Above 960.0	500	3m	500	20log 500

15.205 Restricted bands of operation

MHz	MHz	MHz	GHz
0.090 - 0.110	16.42 - 16.423	399.9 - 410	4.5 - 5.15
¹ 0.495 - 0.505	16.69475 - 16.69525	608 - 614	5.35 - 5.46
2.1735 - 2.1905	16.80425 - 16.80475	960 - 1240	7.25 - 7.75
4.125 - 4.128	25.5 - 25.67	1300 - 1427	8.025 - 8.5
4.17725 - 4.17775	37.5 - 38.25	1435 - 1626.5	9.0 - 9.2
4.20725 - 4.20775	73 - 74.6	1645.5 - 1646.5	9.3 - 9.5
6.215 - 6.218	74.8 - 75.2	1660 - 1710	10.6 - 12.7
6.26775 - 6.26825	108 - 121.94	1718.8 - 1722.2	13.25 - 13.4
6.31175 - 6.31225	123 - 138	2200 - 2300	14.47 - 14.5
8.291 - 8.294	149.9 - 150.05	2310 - 2390	15.35 - 16.2
8.362 - 8.366	156.52475 - 156.52525	2483.5 - 2500	17.7 - 21.4
8.37625 - 8.38675	156.7 - 156.9	2690 - 2900	22.01 - 23.12
8.41425 - 8.41475	162.0125 - 167.17	3260 - 3267	23.6 - 24.0
12.29 - 12.293	167.72 - 173.2	3332 - 3339	31.2 - 31.8
12.51975 - 12.52025	240 - 285	3345.8 - 3358	36.43 - 36.5
12.57675 - 12.57725	322 - 335.4	3600 - 4400	(²)

- Remark:
1. Emission level in dBuV/m=20 log (uV/m)
 2. Measurement was performed at an antenna to the closed point of EUT distance of meters.
 3. Only spurious frequency is permitted to locate within the Restricted Bands specified in provision of § 15.205, and the emissions located in restricted bands also comply with 15.209 limit.

6.5.Measurement Result

Operation Mode:	Low frequency	Test Date :	02/24/2022
Frequency Range:	9KHz~30MHz	Temperature :	20°C
Test Result:	PASS	Humidity :	55 %
Measured Distance:	3m	Test By:	Xia

Freq. (MHz)	Ant.Pol. H/V	Emission Level (dBuV/m)	Limit 3m (dBuV/m)	Over (dB)	Note
0.11407	H	74.64	106.46	-31.82	PK
0.161	H	67.23	103.45	-36.22	PK
0.255	H	65.19	99.48	-34.29	PK
0.406	H	67.35	95.43	-28.09	PK
0.540	H	64.55	72.95	-8.40	PK
0.11625	V	75.93	106.30	-30.36	PK
0.215	V	66.59	100.97	-34.37	PK
0.345	V	65.50	96.86	-31.36	PK
0.466	V	64.04	94.23	-30.18	PK
0.626	V	65.37	71.68	-6.31	PK

- Note:** (1) All Readings are Peak Value.
 (2) Emission Level= Reading Level+Probe Factor +Cable Loss.
 (3) The average measurement was not performed when the peak measured data under the limit of average detection.
 (4) EUT lying on the table position is the worst case result in the report.

30MHz-1GHz:

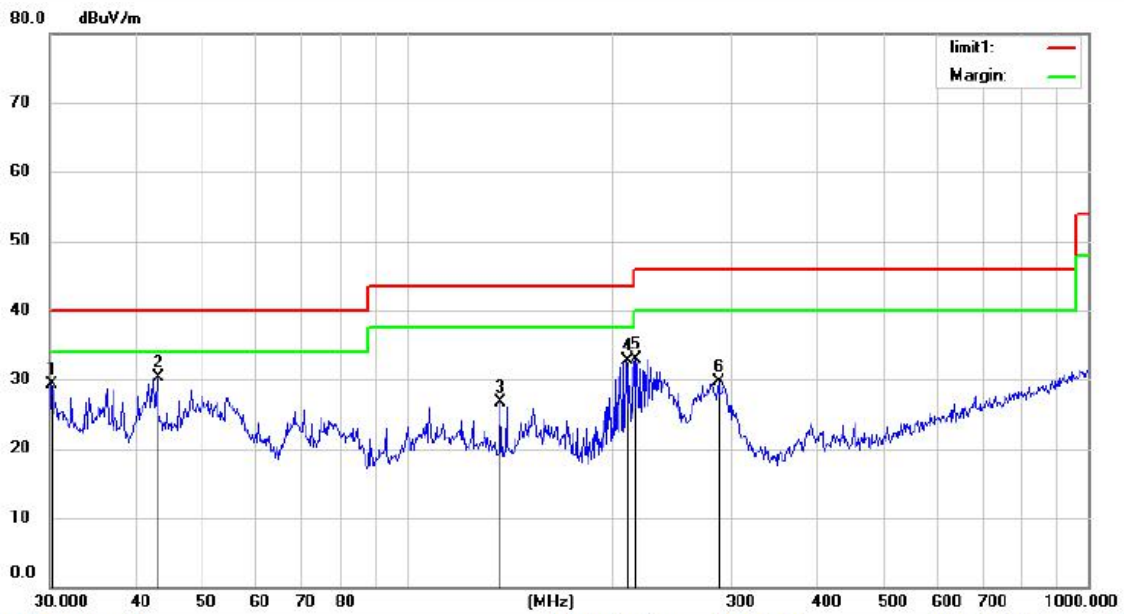

Site Chamber #1 Polarization: **Vertical** Temperature: 22.8
 Limit: FCC PART 15 B 3m(RE) Power: AC 120V/60Hz Humidity: 56 %
 Mode: Wireless Charging(10W)
 Note:

No.	Mk.	Freq. MHz	Reading Level dBuV	Correct Factor dB	Measure- ment dBuV/m	Limit dBuV/m	Over dB	Antenna Height cm	Table Degree	Comment
1		30.1054	47.50	-18.15	29.35	40.00	-10.65			QP
2	*	43.0505	46.11	-15.88	30.23	40.00	-9.77			QP
3		137.4202	47.11	-20.33	26.78	43.50	-16.72			QP
4		210.0482	47.96	-15.27	32.69	43.50	-10.81			QP
5		216.7828	48.00	-15.03	32.97	46.00	-13.03			QP
6		286.9823	42.67	-12.97	29.70	46.00	-16.30			QP

*:Maximum data x:Over limit !:over margin

Operator: Ccyf

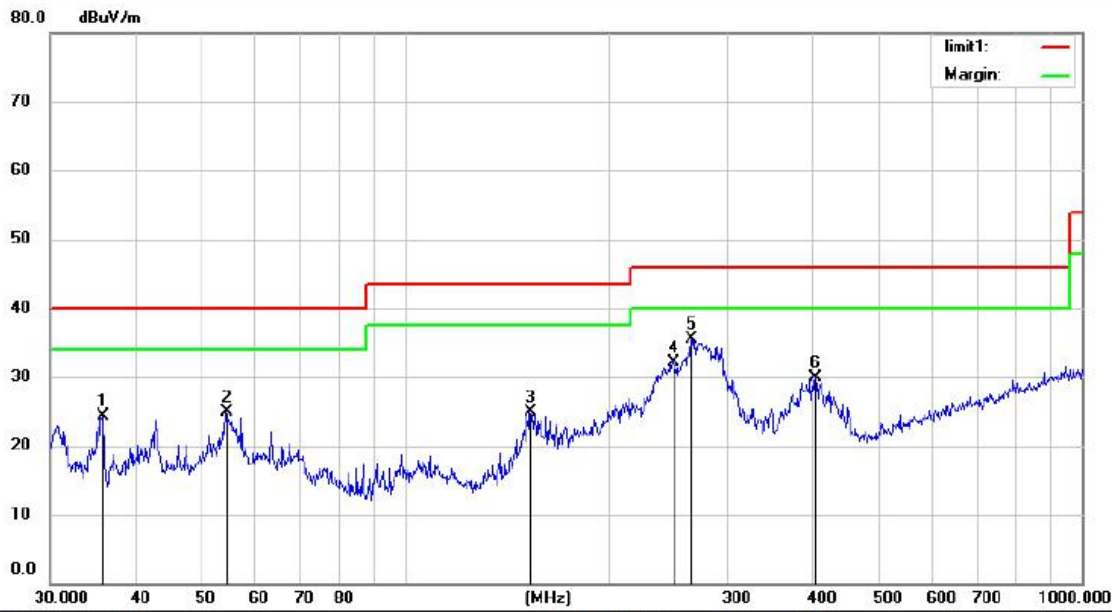

Site Chamber #1 Polarization: **Horizontal** Temperature: 22.8
 Limit: FCC PART 15 B 3m(RE) Power: AC 120V/60Hz Humidity: 56 %
 Mode: Wireless Charging(10W)
 Note:

No.	Mk.	Freq. MHz	Reading Level dBuV	Correct Factor dB	Measure- ment dBuV/m	Limit dBuV/m	Over dB	Antenna Height cm	Table Degree degree	Comment
1		35.8746	41.93	-17.60	24.33	40.00	-15.67			QP
2		54.4516	40.62	-15.74	24.88	40.00	-15.12			QP
3		153.2004	44.48	-19.58	24.90	43.50	-18.60			QP
4		248.5520	46.00	-13.89	32.11	46.00	-13.89			QP
5	*	265.6757	49.06	-13.47	35.59	46.00	-10.41			QP
6		404.6665	39.94	-10.07	29.87	46.00	-16.13			QP

*:Maximum data x:Over limit !:over margin

Operator: Ccyf

7. ANTENNA REQUIREMENT

The EUT's antenna, permanent attached antenna, used an Induction coil, The antenna's gain meets the requirement.



*** End of Report ***

声明

Statement

1. 本报告无授权批准人签字及“检验报告专用章”无效；

This report will be void without authorized signature or special seal for testing report.

2. 未经许可本报告不得部分复制；

This report shall not be copied partly without authorization.

3. 本报告的检测结果仅对送测样品有效，委托方对样品的代表性和资料的真实性负责；

The test results or observations are applicable only to tested sample. Client shall be responsible for representativeness of the sample and authenticity of the material.

4. 本检测报告中检测项目标注有特殊符号则该项目不在资质认定范围内，仅作为客户委托、科研、教学或内部质量控制等目的使用；

The observations or tests with special mark fall outside the scope of accreditation, and are only used for purpose of commission, research, training, internal quality control etc.

5. 本检测报告以实测值进行符合性判定，未考虑不确定度所带来的风险，本实验室不承担相关责任，特别约定、标准或规范中有明确规定的除外；

The test results or observations are provided in accordance with measured value, without taking risks caused by uncertainty into account. Without explicit stipulation in special agreements, standards or regulations, EMTEK shall not assume any responsibility.

6. 对本检测报告若有异议，请于收到报告之日起 20 日内提出；

Objections shall be raised within 20 days from the date receiving the report.