

RF TEST REPORT for Intentional Radiator
No. 161101396SHA-001

Applicant : Hangzhou Gubei Electronics Technology Co., Ltd
Room106, No.1 Building, No.611 Jianghong Road
Binjiang, Hangzhou, China
Manufacturer : Hangzhou Gubei Electronics Technology Co., Ltd
Room106, No.1 Building, No.611 Jianghong Road
Binjiang, Hangzhou, China
Product Name : WIFI Module
Type/Model : WT1SBSL

SUMMARY

The equipment complies with the requirements according to the following standard(s):

47CFR Part 15 (2016): Radio Frequency Devices

ANSI C63.10 (2013): American National Standard for Testing Unlicensed Wireless Devices

RSS-247 Issue 1 (May 2015): Digital Transmission Systems (DTSs), Frequency Hopping Systems (FHSs) and Licence-Exempt Local Area Network (LE-LAN) Devices

RSS-Gen Issue 4 (November 2014): General Requirements for Compliance of Radio Apparatus

Date of issue: January 4, 2017

Prepared by:



Wade Zhang (*Project Engineer*)

Reviewed by:

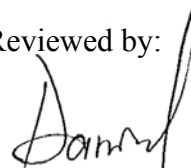

Daniel Zhao (*Reviewer*)



FCC ID: 2ACDZ-3301SBSL
IC: 21239-3301SBSL

Description of Test Facility

Name: Intertek Testing Services Limited Shanghai
Address: Building No.86, 1198 Qinzhou Road(North), Shanghai 200233, P.R.
China

FCC Registration Number: 236597
IC Assigned Code: 2042B-1

Name of contact: Jonny Jing
Tel: +86 21 61278271
Fax: +86 21 54262353

Content

SUMMARY	1
DESCRIPTION OF TEST FACILITY	2
1. TEST SUMMARY	4
2. GENERAL INFORMATION	5
2.1 Applicant Information	5
2.2 Identification of the EUT.....	5
2.3 Technical specification.....	6
3. TEST SPECIFICATION	7
3.1 Instrument list.....	7
3.2 Test Standard	7
3.3 Mode of operation during the test / Test peripherals used	8
4. MINIMUM 6DB BANDWIDTH	10
4.1 Limit	10
4.2 Test Configuration.....	10
4.3 Test Procedure and test setup	10
4.4 Test Protocol.....	11
5. MAXIMUM CONDUCTED OUTPUT POWER	18
5.1 Test limit.....	18
5.2 Test Configuration.....	18
5.3 Test procedure and test setup	18
5.4 Test protocol.....	19
6. POWER SPECTRUM DENSITY	20
6.1 Test limit.....	20
6.2 Test Configuration.....	20
6.3 Test procedure and test setup	21
6.4 Test Protocol.....	21
7. EMISSIONS IN NON-RESTRICTED FREQUENCY BANDS	28
7.1 Test limit.....	28
7.2 Test Configuration.....	28
7.3 Test procedure and test setup	28
7.4 Test Protocol.....	29
8. RADIATED EMISSIONS IN RESTRICTED FREQUENCY BANDS	48
8.1 Test limit.....	48
8.2 Test Configuration.....	48
8.3 Test procedure and test setup	49
8.4 Test Protocol.....	50
9. POWER LINE CONDUCTED EMISSION	56
9.1 Limit	56
9.2 Test configuration.....	56
9.3 Test procedure and test set up	57
9.4 Test protocol.....	58

1. Test Summary

This report applies to tested sample only. This report shall not be reproduced in part without written approval of Intertek Testing Service Shanghai Limited.

Test Items	FCC Reference	IC REFERENCE	Result
Minimum 6dB Bandwidth	15.247(a)(2)	RSS-247 Issue 1 Annex 5.2	Pass
Output power	15.247(b)	RSS-247 Issue 1 Annex 5.4	Pass
Power spectrum density	15.247(e)	RSS-247 Issue 1 Annex 5.2	Pass
Emissions in non-restricted frequency bands	15.247(d)	RSS-247 Issue 1 Annex 5.5	Pass
Emissions in restricted frequency bands	15.247(d) & 15.205 & 15.209	RSS-Gen Issue 4 Clause 8.9	Pass
Power line conducted emission	15.207	RSS-Gen Issue 4 Clause 8.8	Pass

Note: NA =Not Applicable



2. General Information

2.1 Applicant Information

Applicant : Hangzhou Gubei Electronics Technology Co., Ltd
Room106, No.1 Building, No.611 Jianghong Road Binjiang,
Hangzhou, China

Name of contact : Yan Mengjiao

Tel : 18058715209

Fax : 0571-86691817

Manufacturer : Hangzhou Gubei Electronics Technology Co., Ltd
Room106, No.1 Building, No.611 Jianghong Road Binjiang,
Hangzhou, China

2.2 Identification of the EUT

Equipment : WIFI Module

Type/model : WT1SBSL

FCC ID : 2ACDZ-3301SBSL

IC : 21239-3301SBSL

2.3 Technical specification

Operation Frequency : 2412~2462 MHz
Band

Type of Modulation : CCK,BPSK,QPSK,DSSS,OFDM
OFDM(BPSK,QPSK,16QAM,64QAM)

EUT Modes of : 802.11b/g;
Modulation : 802.11n HT20,HT40;

Channel Number : 11Channel for 2412MHz~2462MHz for 11b,11g,11n(H20);
7 Channel for 2422MHz~2452MHz for 11n HT40;

Description of EUT : The EUT is a WIFI module, it support 2.4G band, and there have only one model. We tested it and listed the 2.4G band results in this report.

Port identification : /

Rating : DC 3.3V

Antenna : 1.45dBi Integral PCB Antenna

Declared Temperature : 0°C ~ 50°C
range

Category of EUT : Class B

EUT type : Table top Floor standing

Sample received date : November 23, 2016

Sample Identification : *0161123-04-001*
No

Date of test : November 23, 2016 ~ December 22, 2016

3. Test Specification

3.1 Instrument list

Selected	Equipment	Type	Manu.	Internal no.	Cal. Date	Due date
<input checked="" type="checkbox"/>	PXA Analyzer	N9030A	Agilent	EC5338	2016/3/4	2017/3/3
<input checked="" type="checkbox"/>	Vector SG	N5182B	Agilent	EC5175	2016/3/4	2017/3/3
<input checked="" type="checkbox"/>	Power sensor	U2021XA	Agilent	EC5338-1	2016/3/4	2017/3/3
<input checked="" type="checkbox"/>	MXG Analog SG	N5181A	Agilent	EC5338-2	2016/3/4	2017/3/3
<input checked="" type="checkbox"/>	Power meter	N1911A/N1921A	Agilent	EC4318	2016/4/10	2017/4/9
<input checked="" type="checkbox"/>	EMI Receiver	ESCS 30	R&S	EC 2107	2016/10/19	2017/10/18
<input checked="" type="checkbox"/>	A.M.N.	ESH2-Z5	R&S	EC 3119	2015/12/16	2017/12/15
<input checked="" type="checkbox"/>	I.S.N.	FCC-TLISN-T8-02	FCC	EC3756	2016/2/16	2017/2/15
<input checked="" type="checkbox"/>	EMI chamber	3m	Albatross	EC 3048	2016/5/5	2017/5/4
<input checked="" type="checkbox"/>	Test Receiver	ESIB 26	R&S	EC 3045	2016/10/19	2017/10/18
<input checked="" type="checkbox"/>	Test Receiver	ESCI 7	R&S	EC4501	2016/2/24	2017/2/23
<input checked="" type="checkbox"/>	Bilog Antenna	CBL 6112D	TESEQ	EC 4206	2016/5/30	2017/5/29
<input checked="" type="checkbox"/>	Horn antenna	HF 906	R&S	EC 3049	2016/9/11	2017/9/10
<input checked="" type="checkbox"/>	Horn antenna	HAP18-26W	TOYO	EC 4792-3	2014/6/12	2017/6/11
<input checked="" type="checkbox"/>	Pre-amplifier	Pre-amp 18	R&S	EC 5262	2016/5/24	2017/5/23
<input checked="" type="checkbox"/>	Pre-amplifier	Tpa0118-40	R&S	EC 4792-2	2016/4/11	2017/4/10
<input checked="" type="checkbox"/>	Shielded room	-	Zhongyu	EC 2838	2016/1/9	2017/1/8

3.2 Test Standard

47CFR Part 15 (2016): Radio Frequency Devices

ANSI C63.10 (2013): American National Standard for Testing Unlicensed Wireless Devices

RSS-247 Issue 1 (May 2015): Digital Transmission Systems (DTSS), Frequency Hopping Systems (FHSs) and Licence-Exempt Local Area Network (LE-LAN) Devices

RSS-Gen Issue 4 (November 2014): General Requirements for Compliance of Radio Apparatus

3.3 Mode of operation during the test / Test peripherals used

Operation Frequency each of channel For 802.11b/g/n20/n40							
Channel	Frequency	Channel	Frequency	Channel	Frequency	Channel	Frequency
1	2412MHz	4	2427MHz	7	2442MHz	10	2457MHz
2	2417MHz	5	2432MHz	8	2447MHz	11	2462MHz
3	2422MHz	6	2437MHz	9	2452MHz	/	

Note:

In section 15.31(m), regards to the operating frequency range over 10 MHz, the Lowest frequency, the middle frequency, and the highest frequency of channel were selected to perform the test as representatives, and the selected channel see below:

Modulation	Lowest(MHz)	Middle(MHz)	Highest(MHz)
802.11b	2412	2437	2462
802.11g	2412	2437	2462
802.11n20	2412	2437	2462
802.11n(HT40)	2422	2437	2452

While testing transmitting mode of EUT, the internal modulation and continuously transmission was applied.

The test setting software and command is offered by the manufactory.

We have verified the construction and function in typical operation. All the test modes were carried out with the EUT in transmitting operation, the pre-scan for all data rates in each modulation and bands was tested, and the worst case was found and used in all test cases.

After this pre-scan, we choose the following table of the data rata as the final test mode.

Modulation	Data rate
802.11b	1Mbps
802.11g	6Mbps
802.11n HT20	MCS0
802.11n HT40	MCS0

Duty cycle setting during the transmission is 100% with maximum power setting for all modulations.



Test Mode description:

Radiated test construction:

Mode 1: EUT with antenna;

Conducted test construction:

Mode 2: EUT RF port connected to SPA directly;

Test peripherals used:

Item No	Description	Band and Model	S/No
1	Laptop computer	HP ProBook 6470b	NA
2	USB to RS-232 jet	NA	NA
3	RF Engineering Board	Broadlink	NA
4	Power Supply Adaptor	NA	NA

Note: The accessories are used for configuration and used during test.

4. Minimum 6dB Bandwidth

Test result: Pass

4.1 Limit

For systems using digital modulation techniques that may operate in the 902 - 928 MHz, 2400 - 2483.5 MHz and 5725 - 5850 MHz bands, the minimum 6 dB bandwidth shall be at least 500 kHz.

4.2 Test Configuration

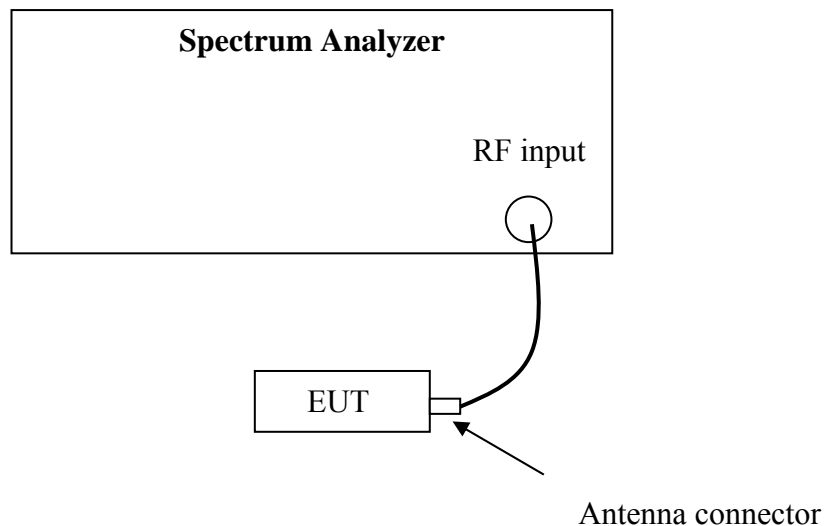

4.3 Test Procedure and test setup

The minimum 6dB bandwidth per FCC §15.247(a)(2) is measured using the Spectrum Analyzer according to DTS test procedure of “KDB558074 D01 DTS Meas Guidance v03r05” for compliance to FCC 47CFR 15.247 requirements (clause 8.1).

- a) Set RBW = 100 kHz.
- b) Set the video bandwidth (VBW) ≥ 3 RBW.
- c) Detector = Peak.
- d) Trace mode = max hold.
- e) Sweep = auto couple.
- f) Allow the trace to stabilize.
- g) Measure the maximum width of the emission that is constrained by the frequencies associated with the two outermost amplitude points (upper and lower frequencies) that are attenuated by 6 dB relative to the maximum level measured in the fundamental emission.

4.4 Test Protocol

Temperature: 22°C
Relative Humidity: 53%

Mode	CH	6dB Emission Bandwidth (MHz)	Limit (MHz)
802.11b	L	10.06	≥0.5
	M	10.06	
	H	10.06	
802.11g	L	16.36	
	M	16.36	
	H	16.37	
802.11n20	L	17.54	
	M	17.56	
	H	17.56	
802.11n40	L	36.35	
	M	36.29	
	H	36.29	

Mode	CH	99% Occupy Bandwidth (MHz)	Limit (MHz)
802.11b	L	12.177	NA
	M	12.171	
	H	12.171	
802.11g	L	16.449	
	M	16.450	
	H	16.452	
802.11n20	L	17.568	
	M	17.562	
	H	17.572	
802.11n40	L	36.164	
	M	36.156	
	H	36.170	

Test plot as follows:

802.11b
Frequency L

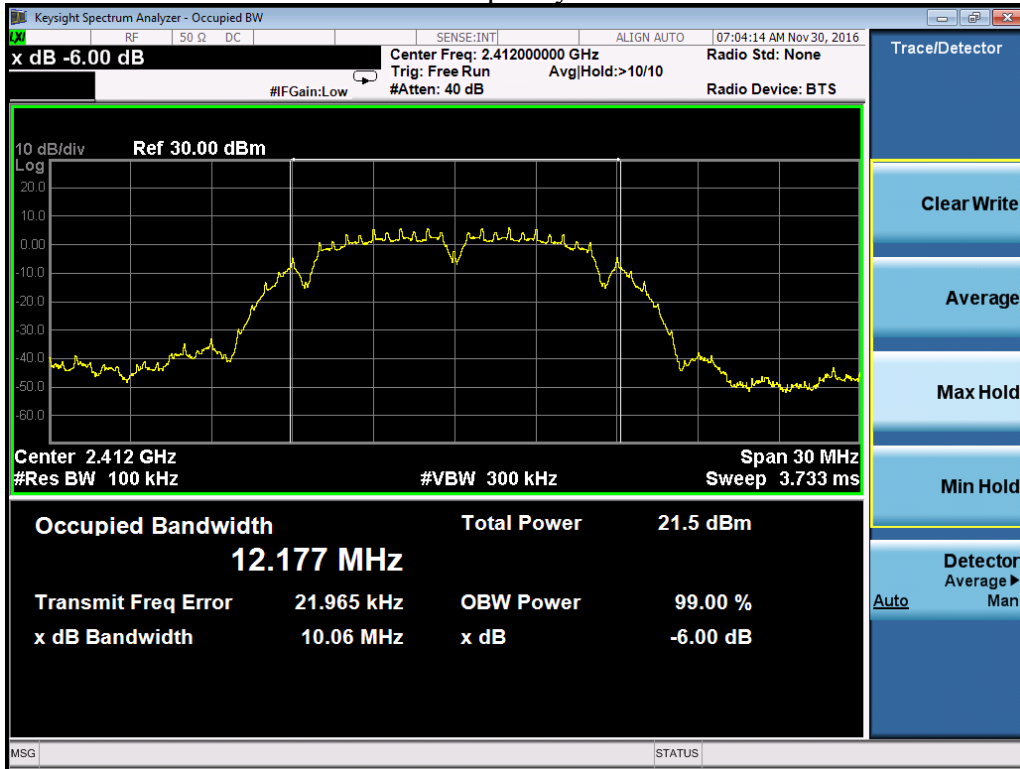

Frequency M

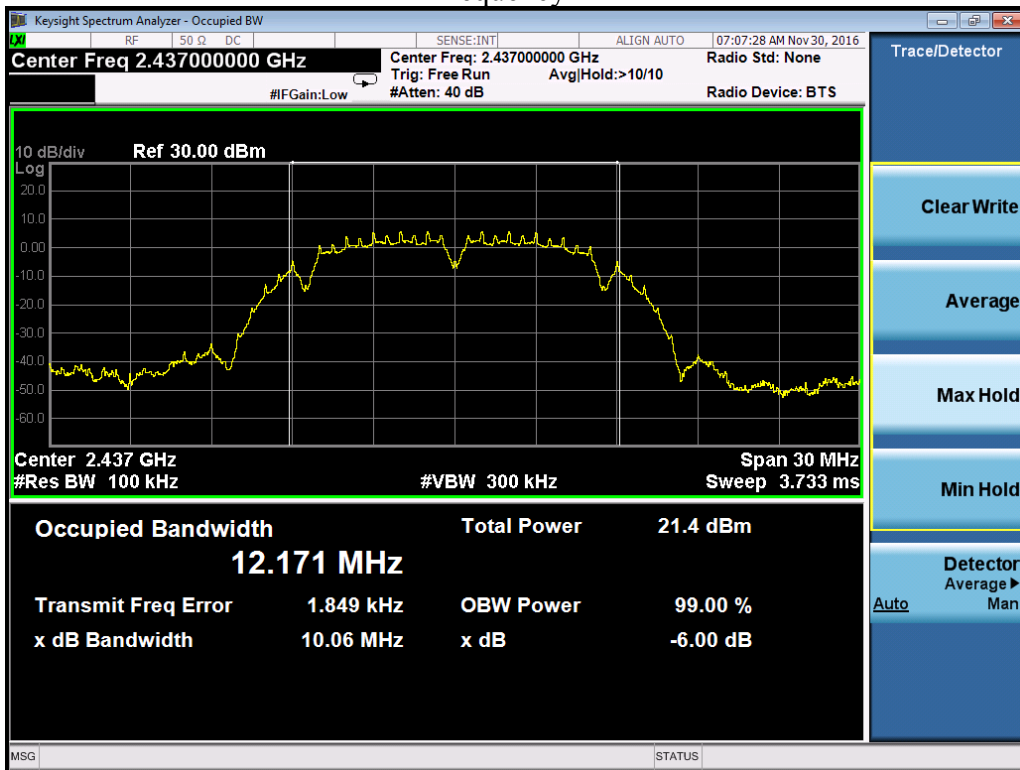

Frequency H

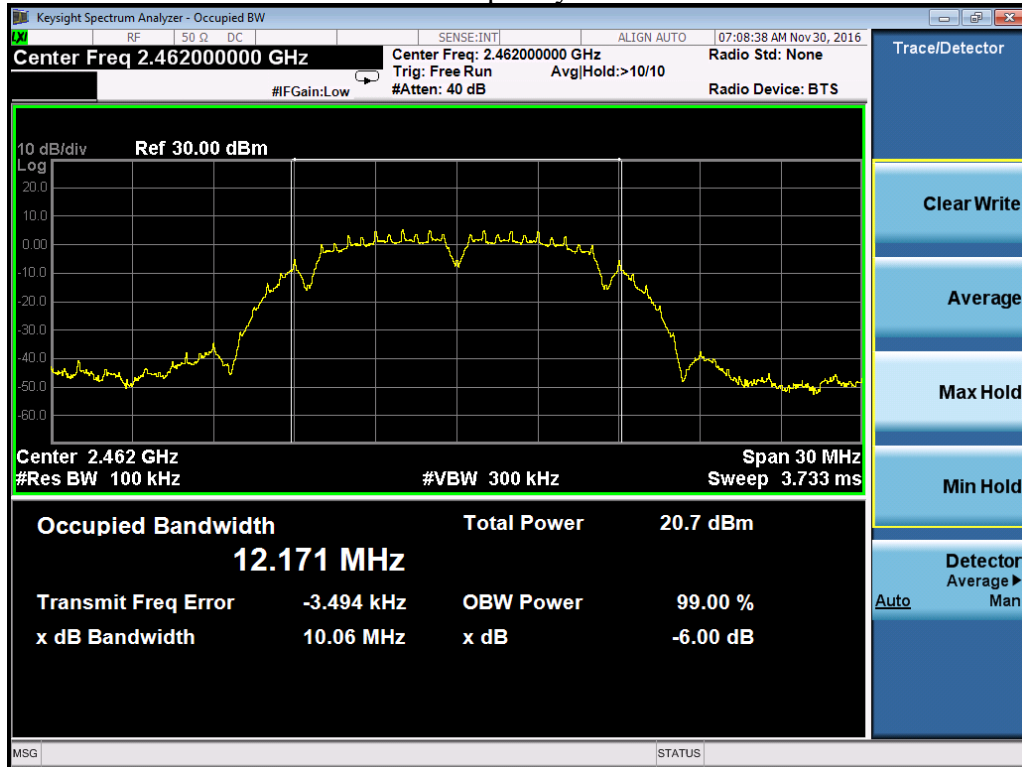

802.11g
Frequency L

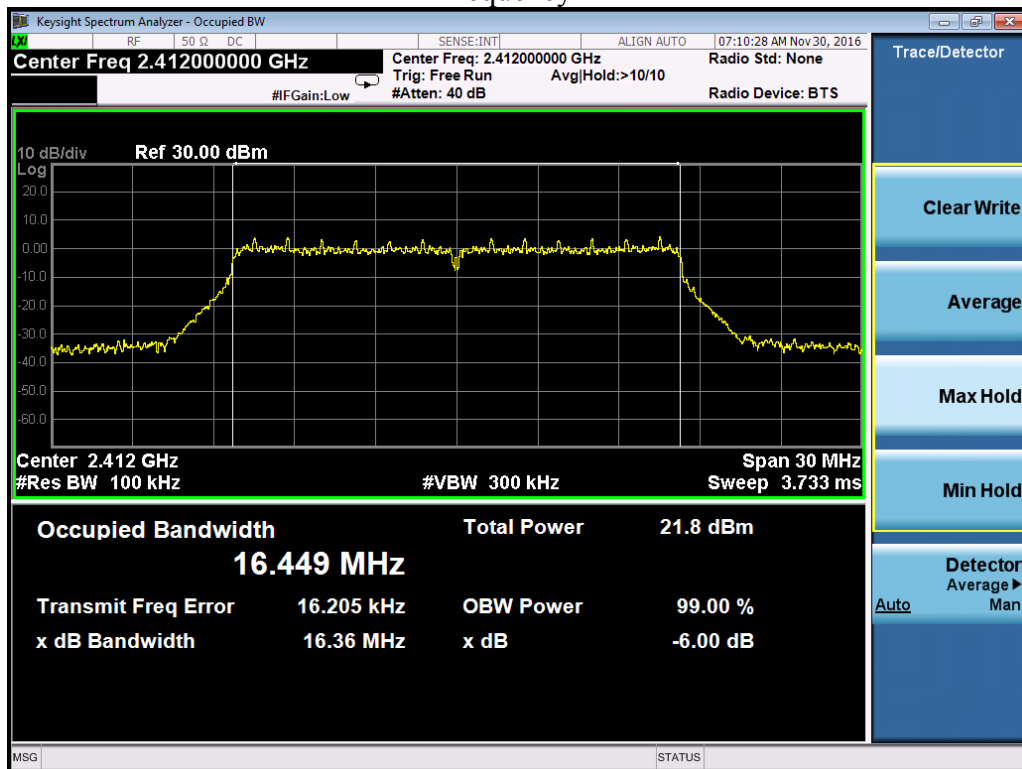

Frequency M

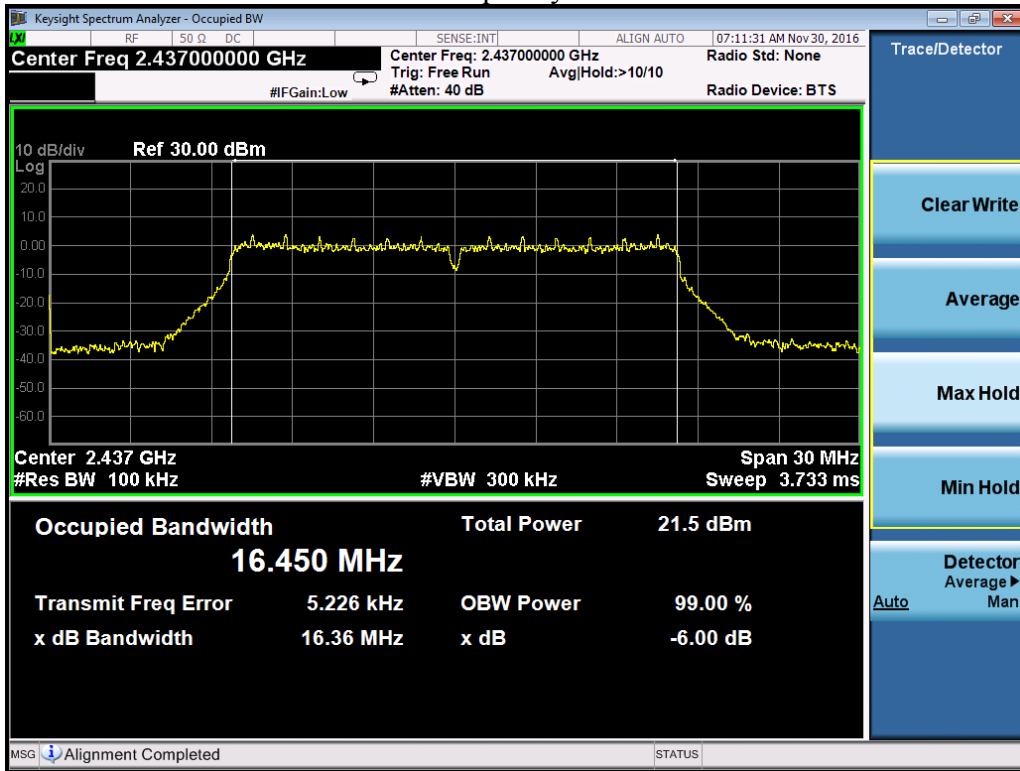

Frequency H

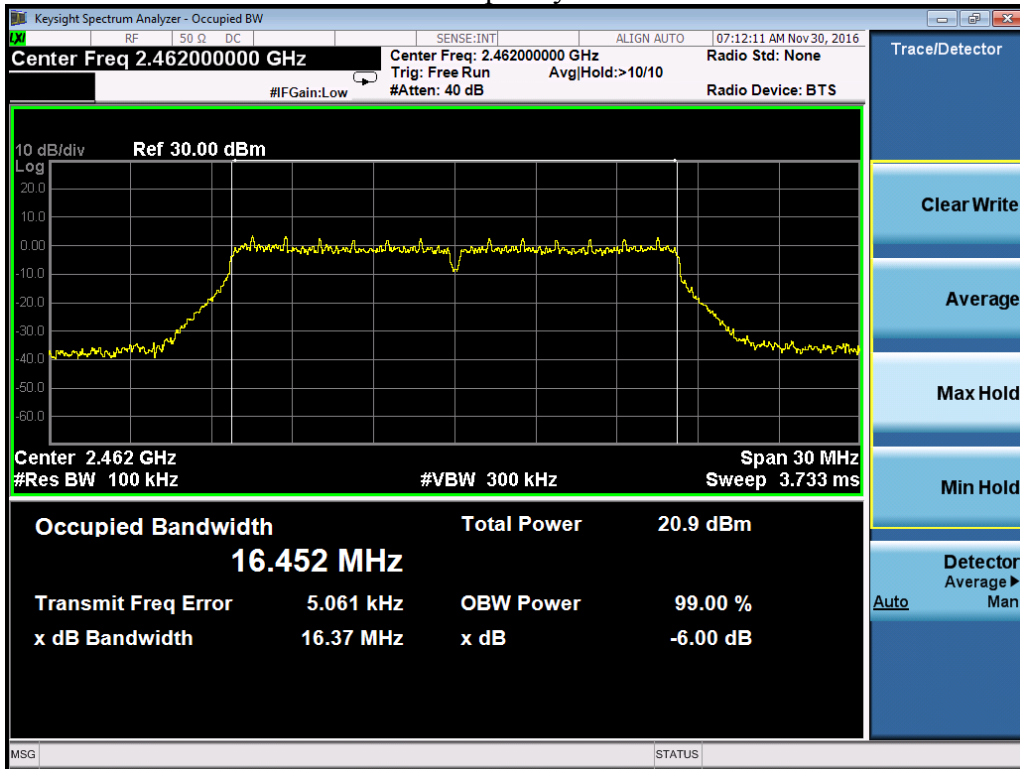

**802.11n20
Frequency L**

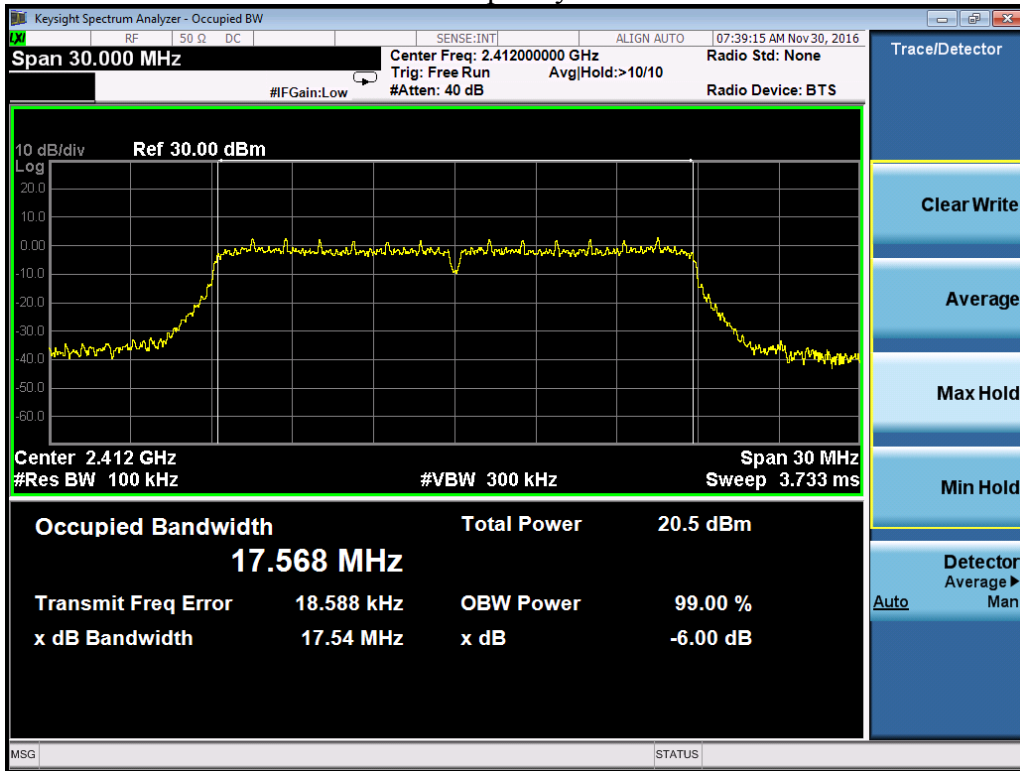

Frequency M

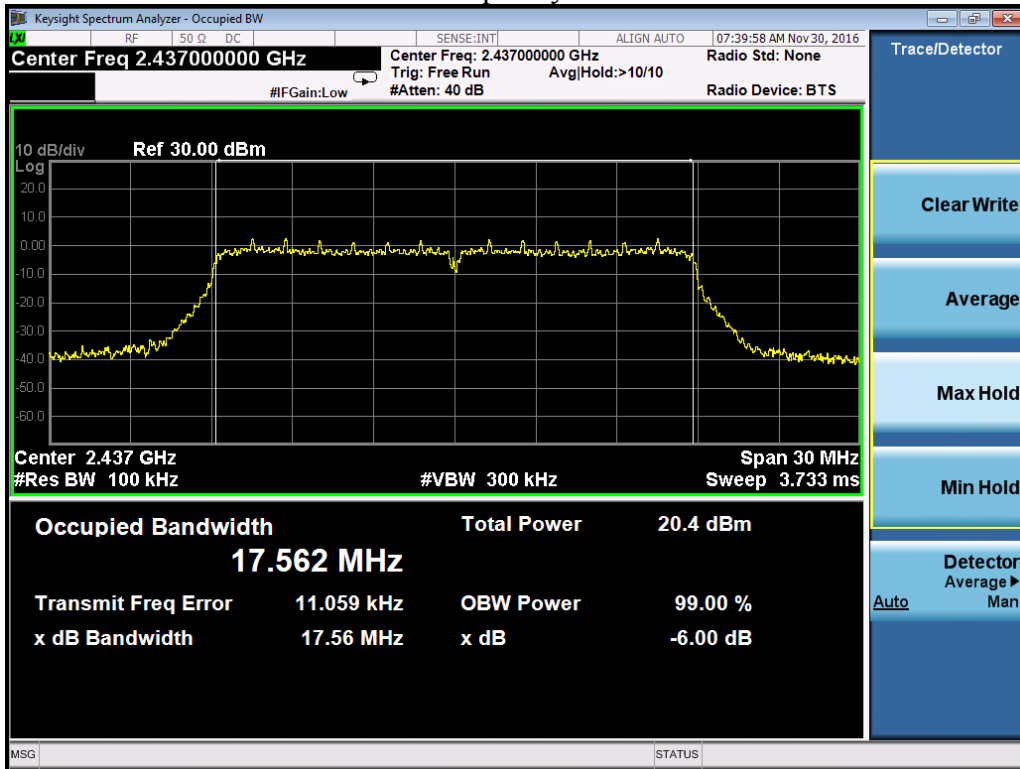

Frequency H

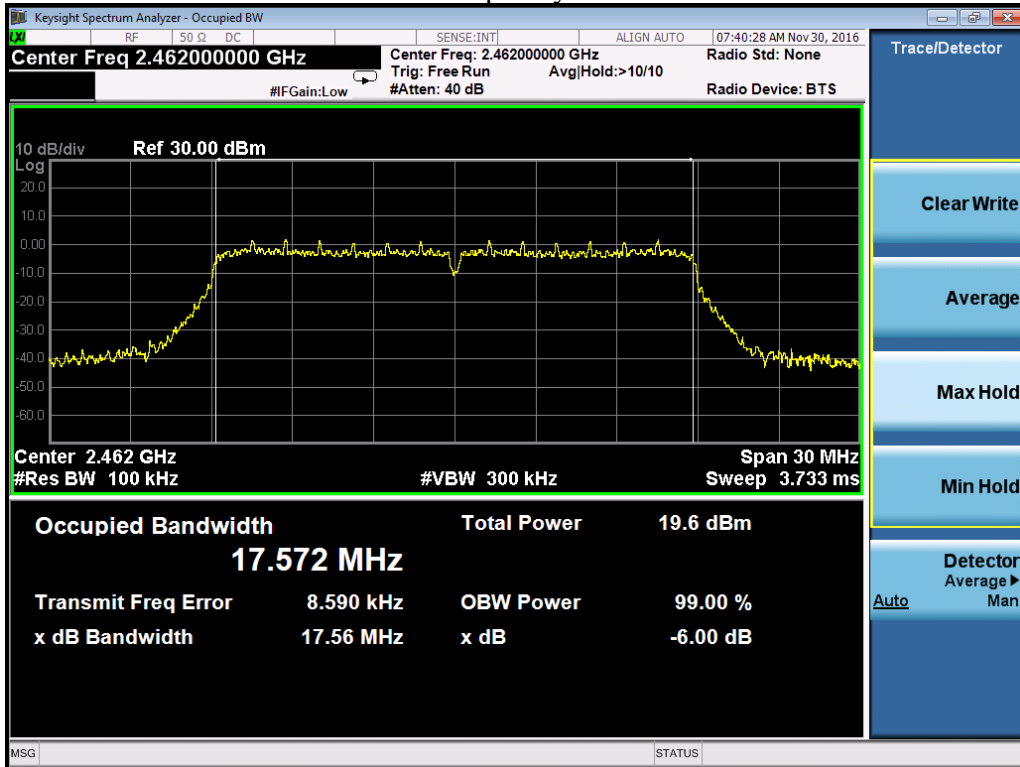

802.11n40 Frequency L

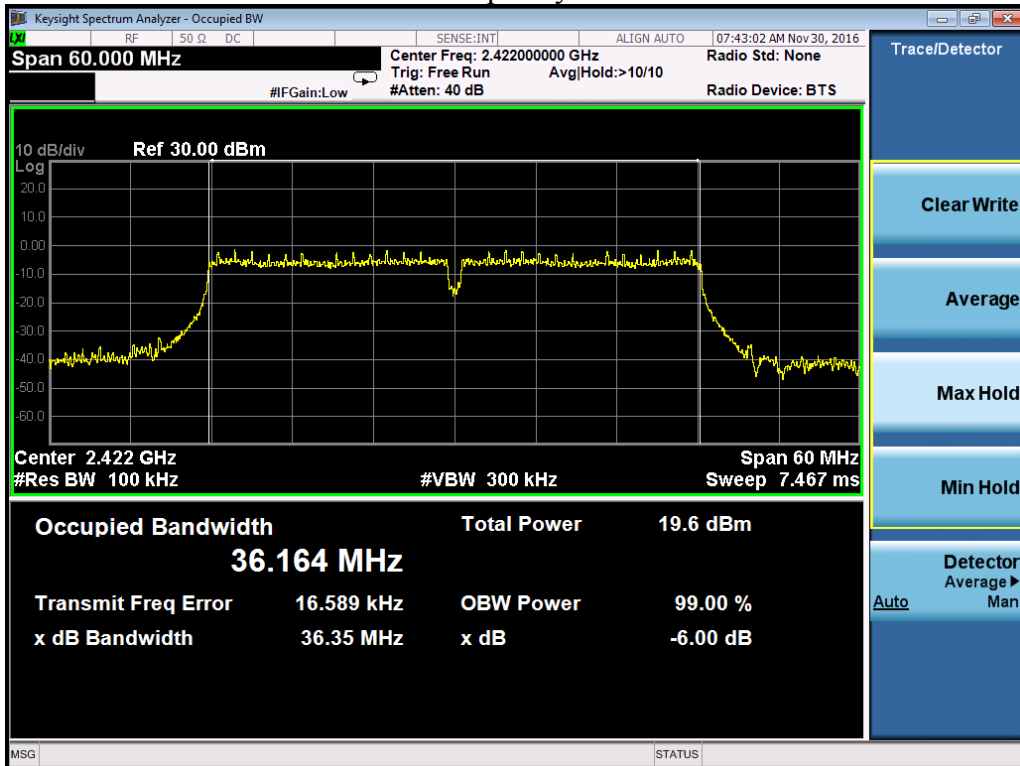

Frequency M

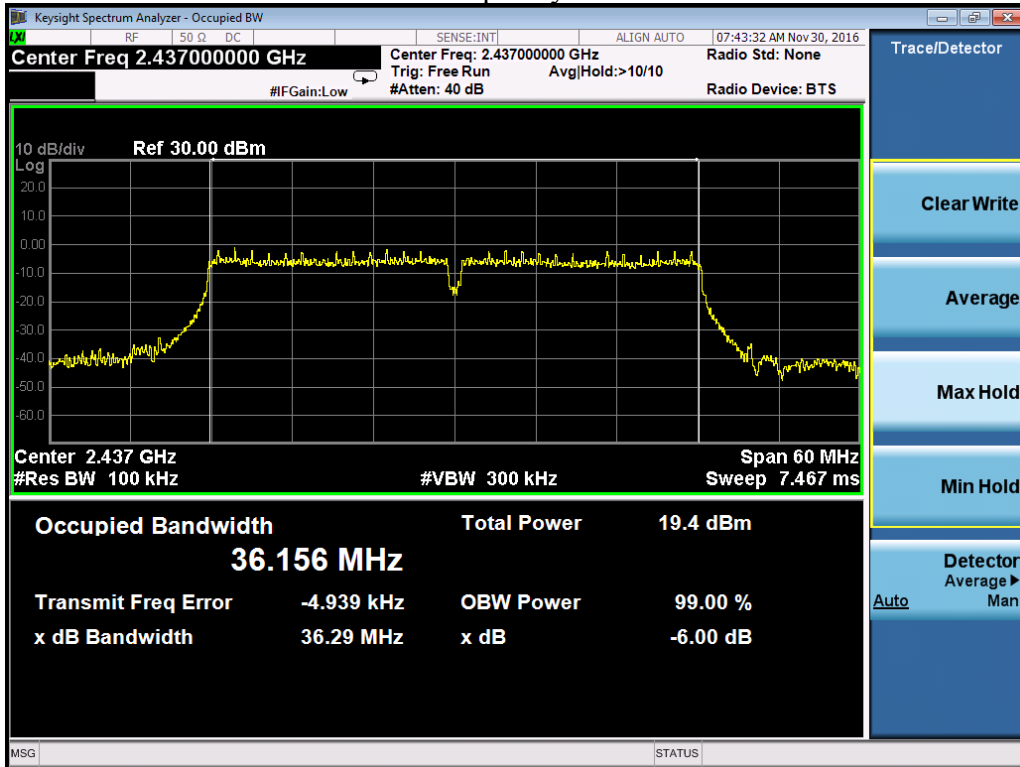

Frequency H

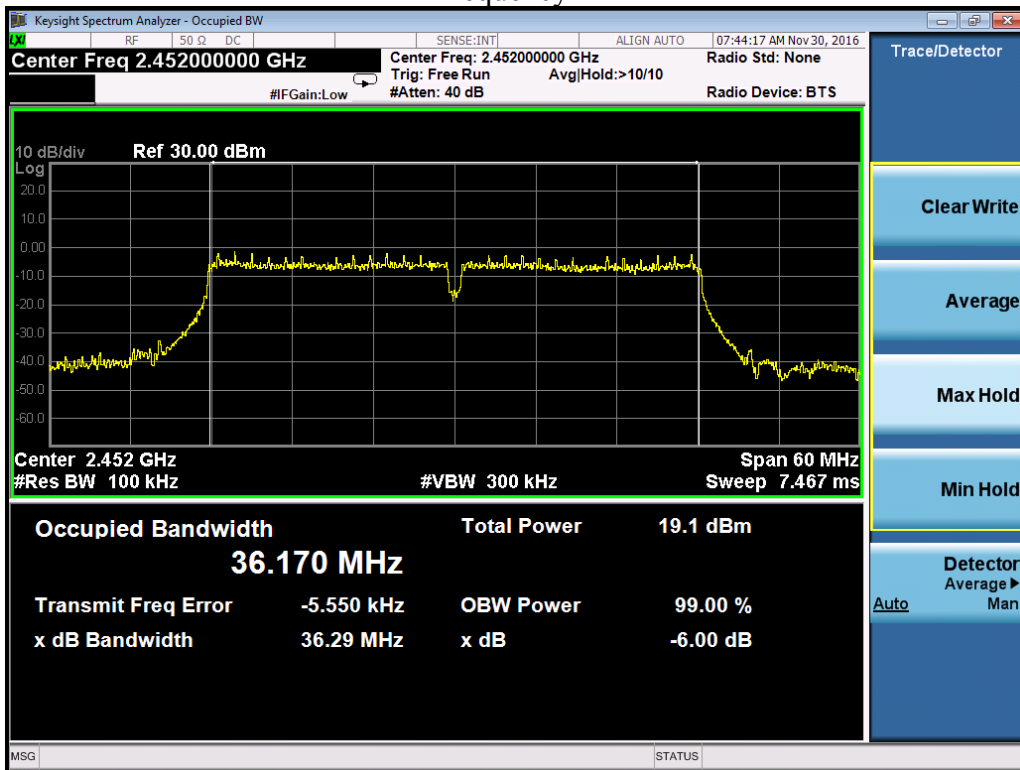

5. Maximum Conducted Output power

Test result: Pass

5.1 Test limit

- For frequency hopping systems operating in the 2400-2483.5 MHz band employing at least 75 non-overlapping hopping channels, and all frequency hopping systems in the 5725-5850 MHz band: 1 watt
- For all other frequency hopping systems in the 2400-2483.5 MHz band: 0.125 watts
- For systems using digital modulation in the 902-928 MHz, 2400-2483.5 MHz, and 5725-5850 MHz bands: 1 Watt.

If the transmitting antenna of directional gain greater than 6dBi is used, the power shall be reduced by the amount in dB that the directional gain of the antenna exceeds 6dBi. If there have a beam forming type, the limit should be the minimum of 30dBm and 30+ (6 –antenna gain-beam forming gain).

5.2 Test Configuration

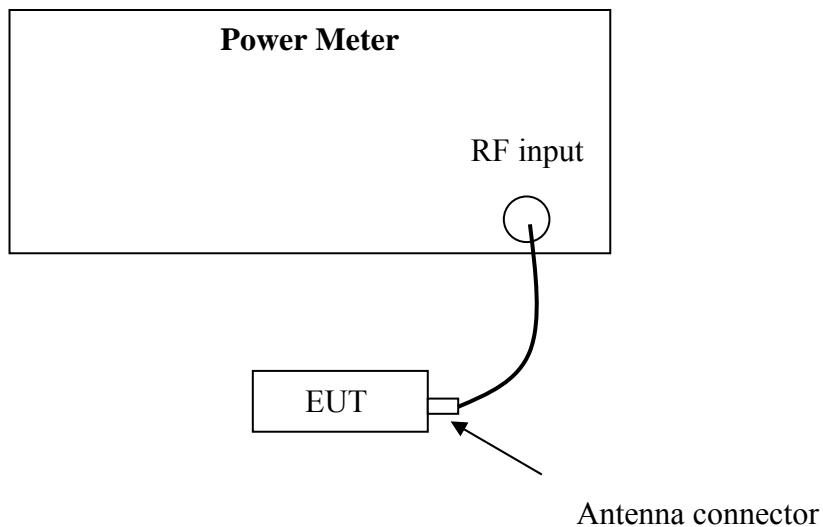

5.3 Test procedure and test setup

The EUT was tested according to DTS test procedure of “KDB558074 D01 DTS Meas Guidance v03r05” for compliance to FCC 47CFR 15.247 requirements (clause 9.1.2).

5.4 Test protocol

Temperature: 22 °C

Relative Humidity: 53 %

Mode	Frequency (MHz)	Reading (dBm)	Limit (dBm)	Margin (dB)
802.11b	2412	17.79	30.00	12.21
	2437	17.58	30.00	12.42
	2462	16.87	30.00	13.13
802.11g	2412	22.27	30.00	7.73
	2437	22.08	30.00	7.92
	2462	21.35	30.00	8.65
802.11n20	2412	20.71	30.00	9.29
	2437	20.51	30.00	9.49
	2462	19.87	30.00	10.13
802.11n40	2422	20.21	30.00	9.79
	2437	20.02	30.00	9.98
	2452	19.66	30.00	10.34

6. Power spectrum density

Test result: Pass

6.1 Test limit

For digitally modulated systems, the power spectral density conducted from the intentional radiator to the antenna shall not be greater than 8dBm in any 3 kHz band during any time interval of continuous transmission.

If the transmitting antenna of directional gain greater than 6dBi is used, the power shall be reduced by the amount in dB that the directional gain of the antenna exceeds 6dBi. If there have a beam forming type, the limit should be the minimum of 8dBm/MHz and 8+ (6 –antenna gain-beam forming gain).

6.2 Test Configuration

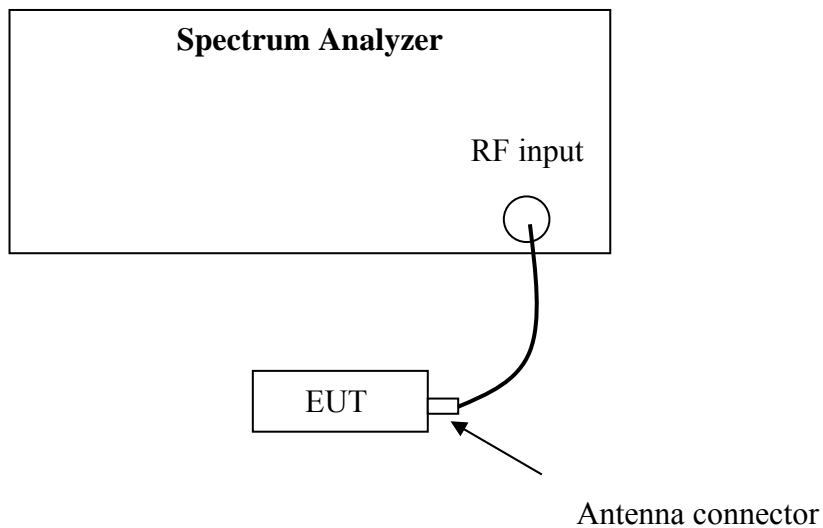

6.3 Test procedure and test setup

The power output per FCC §15.247(e) was tested according to DTS test procedure of “KDB558074 D01 DTS Meas Guidance v03r05” (clause 10.2 Method PKPSD) for compliance to FCC 47CFR 15.247 requirements.

- 1) Set analyzer center frequency to DTS channel center frequency.
- 2) Set the span to 1.5 times the DTS bandwidth.
- 3) Set the RBW to: $3 \text{ kHz} \leq \text{RBW} \leq 100 \text{ kHz}$.
- 4) Set the VBW $\geq 3 \times \text{RBW}$.
- 5) Detector = peak.
- 6) Sweep time = auto couple.
- 7) Trace mode = max hold.
- 8) Allow trace to fully stabilize.
- 9) Use the peak marker function to determine the maximum amplitude level within the RBW.
- 10) If measured value exceeds limit, reduce RBW (no less than 3 kHz) and repeat.

6.4 Test Protocol

Temperature: 22 °C

Relative Humidity: 53 %

Mode	Frequency (MHz)	Max PSD (dBm/100KHz)	Limit (dBm/3KHz)	Margin (dB)
802.11b	2412	7.191	8.00	0.809
	2437	7.040	8.00	0.960
	2462	6.327	8.00	1.673
802.11g	2412	5.912	8.00	2.088
	2437	5.603	8.00	2.397
	2462	4.855	8.00	3.145
802.11 n20	2412	4.490	8.00	3.510
	2437	4.101	8.00	3.899
	2462	3.385	8.00	4.615
802.11 n40	2422	1.113	8.00	6.887
	2437	1.225	8.00	6.775
	2452	0.976	8.00	7.024

Test plot as follows:

802.11b Frequency L

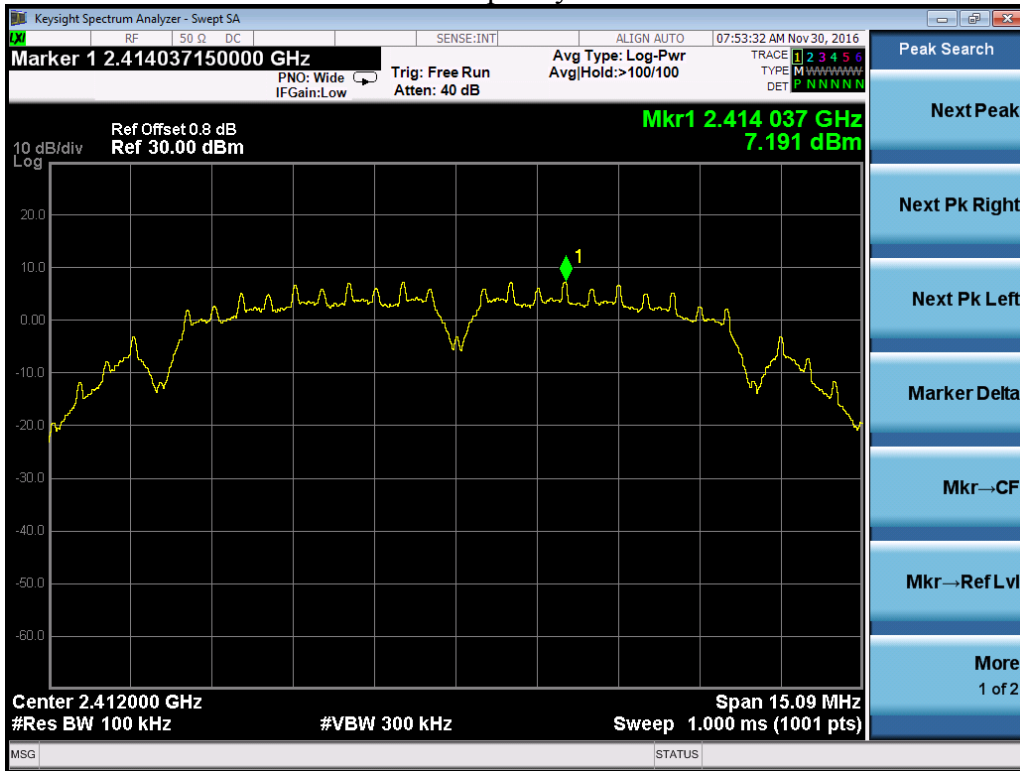

Frequency M

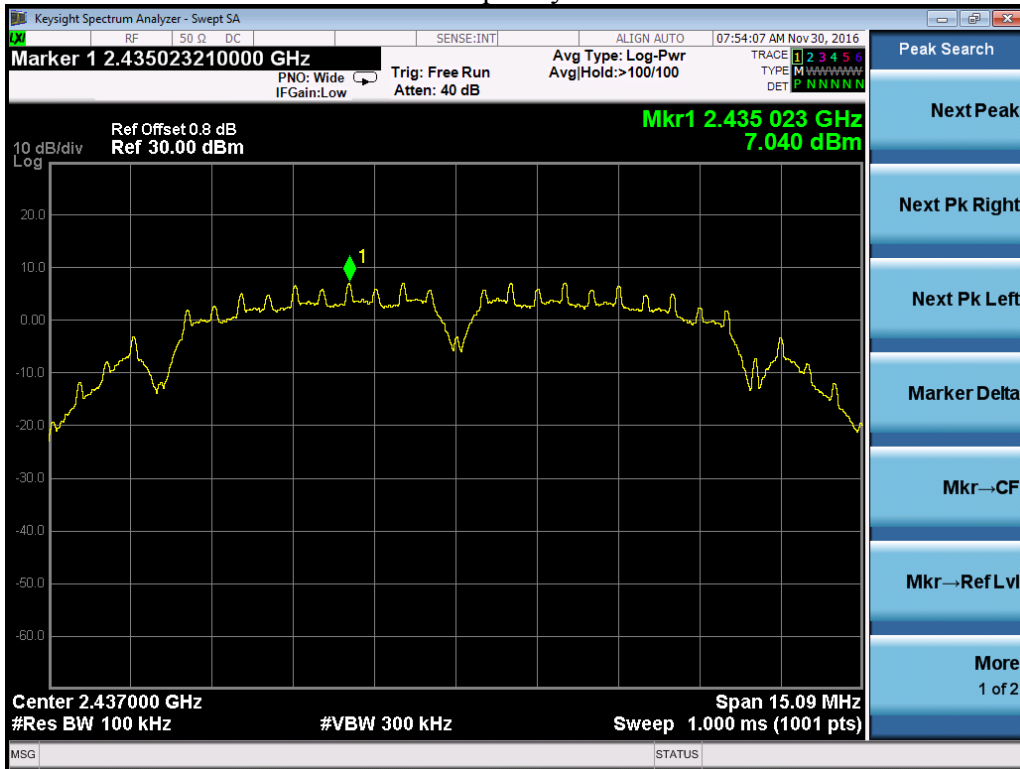

Frequency H

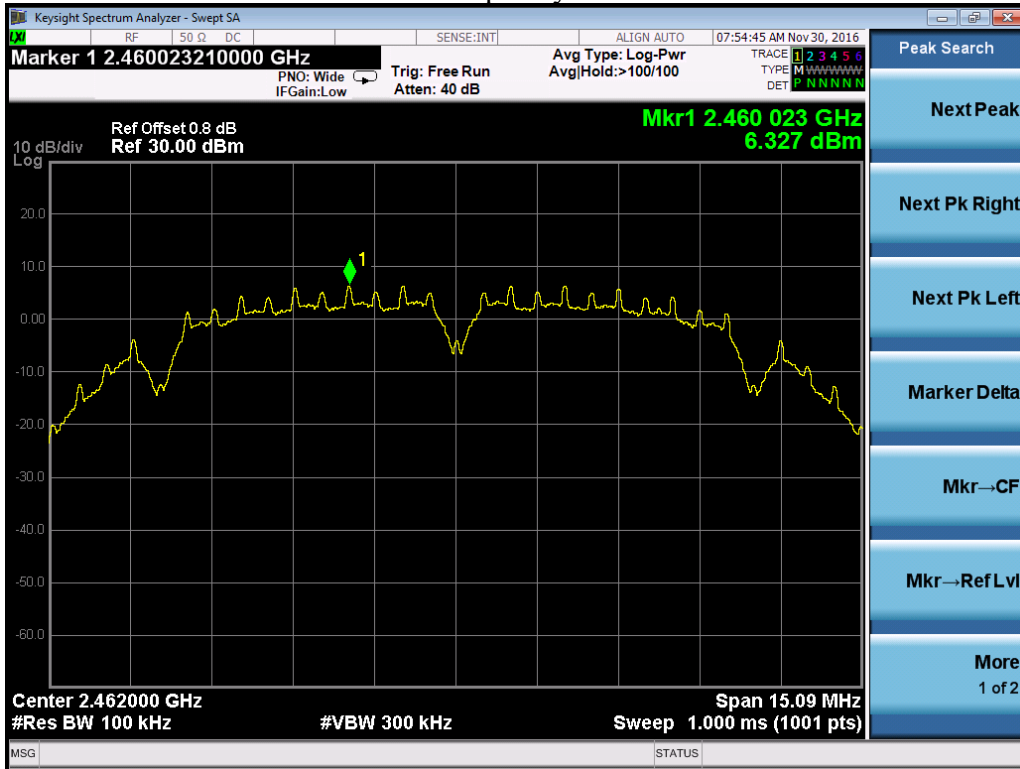

802.11g Frequency L

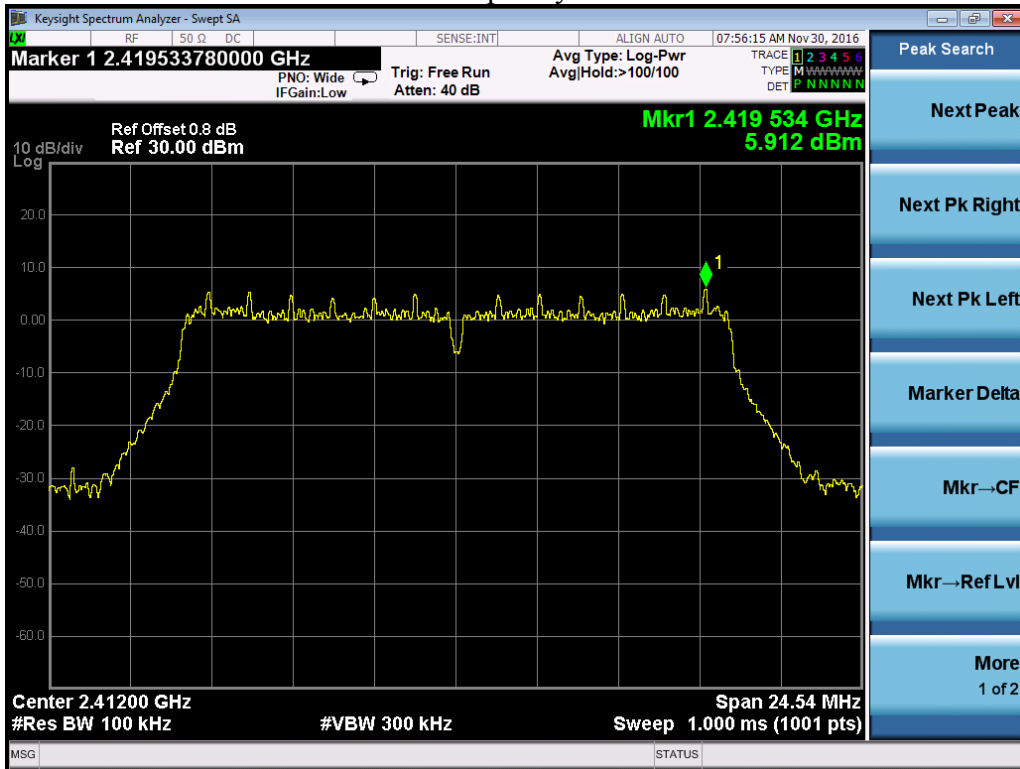

Frequency M

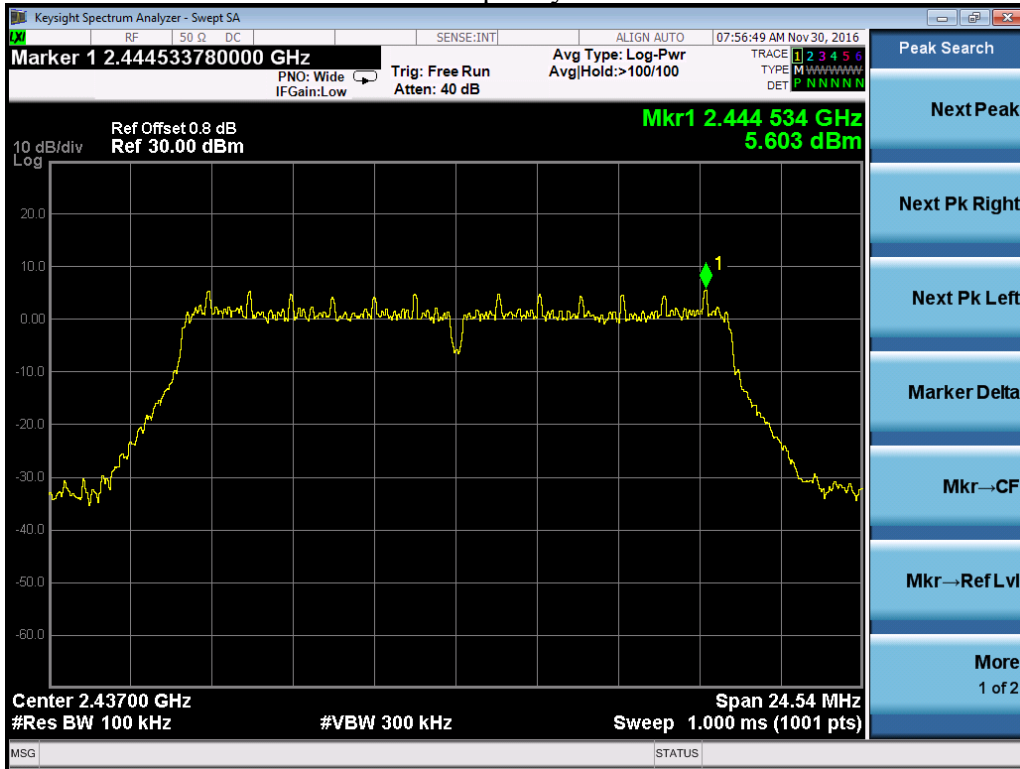

Frequency H

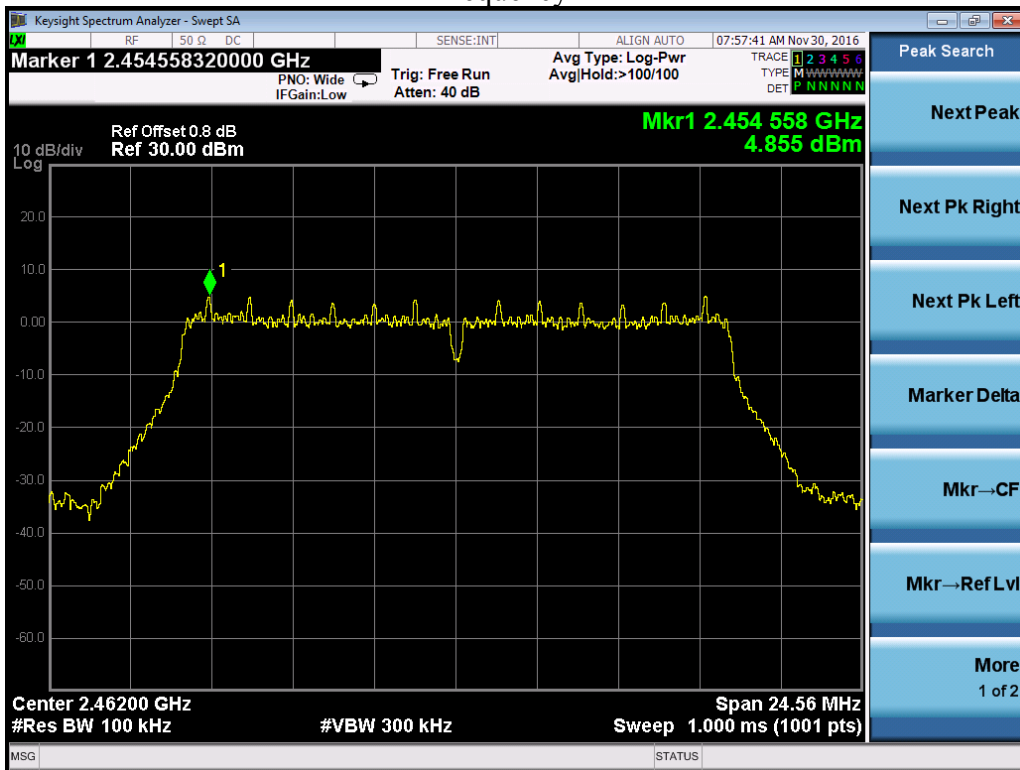

802.11n20
Frequency L

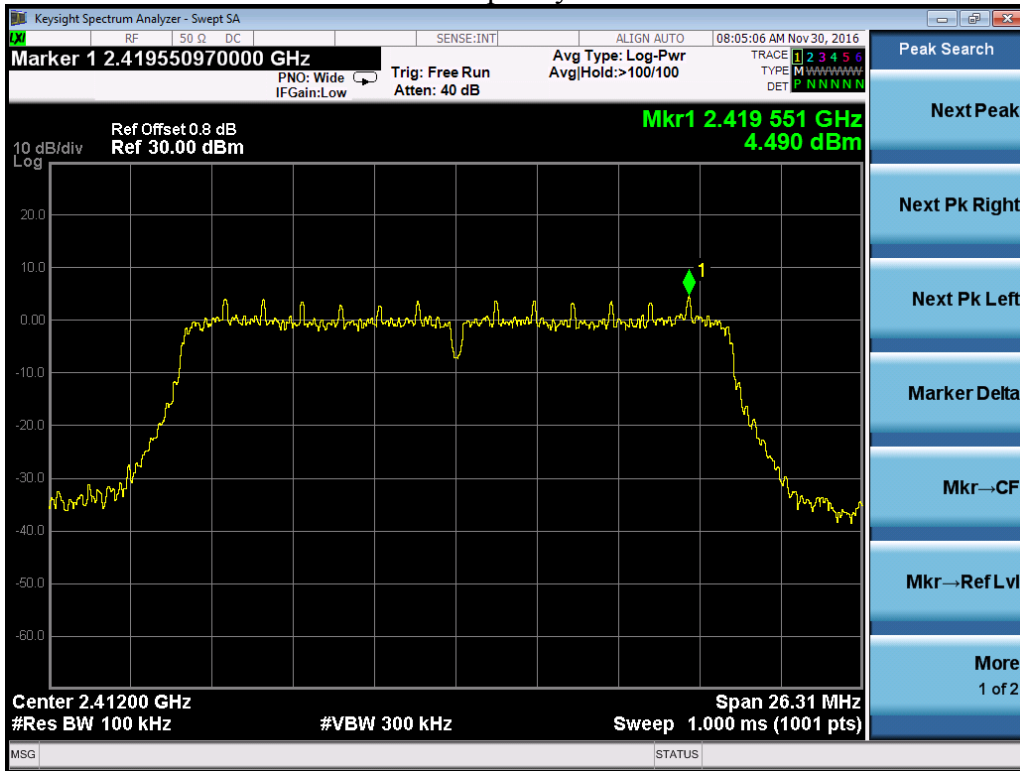

Frequency M

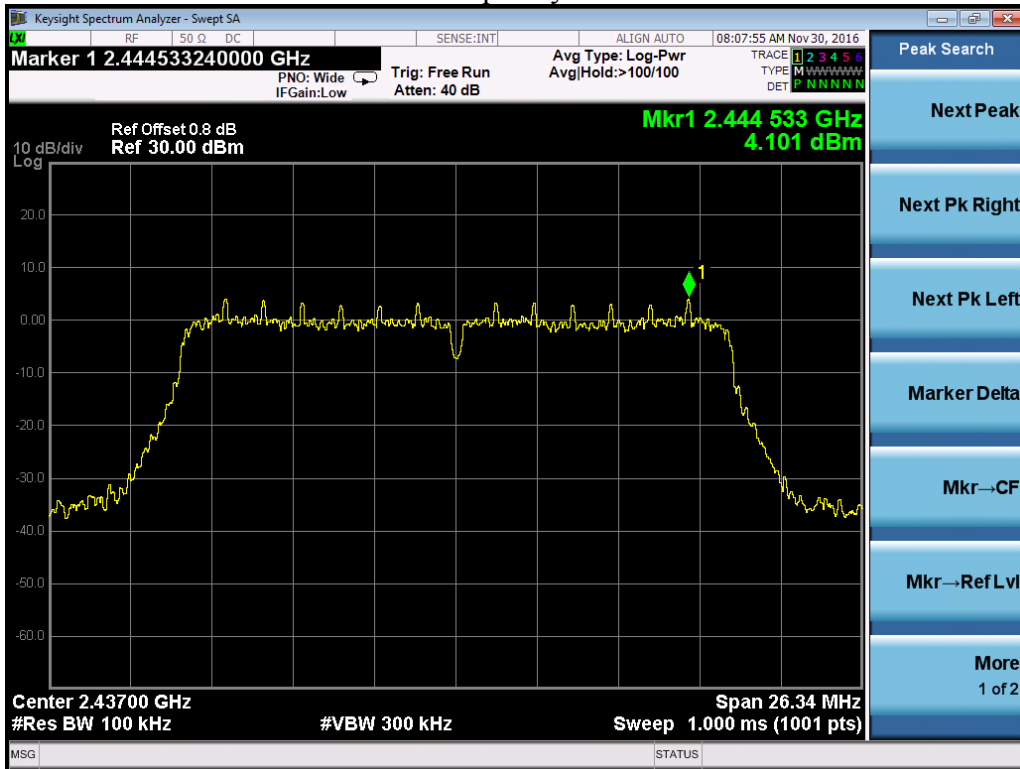

Frequency H

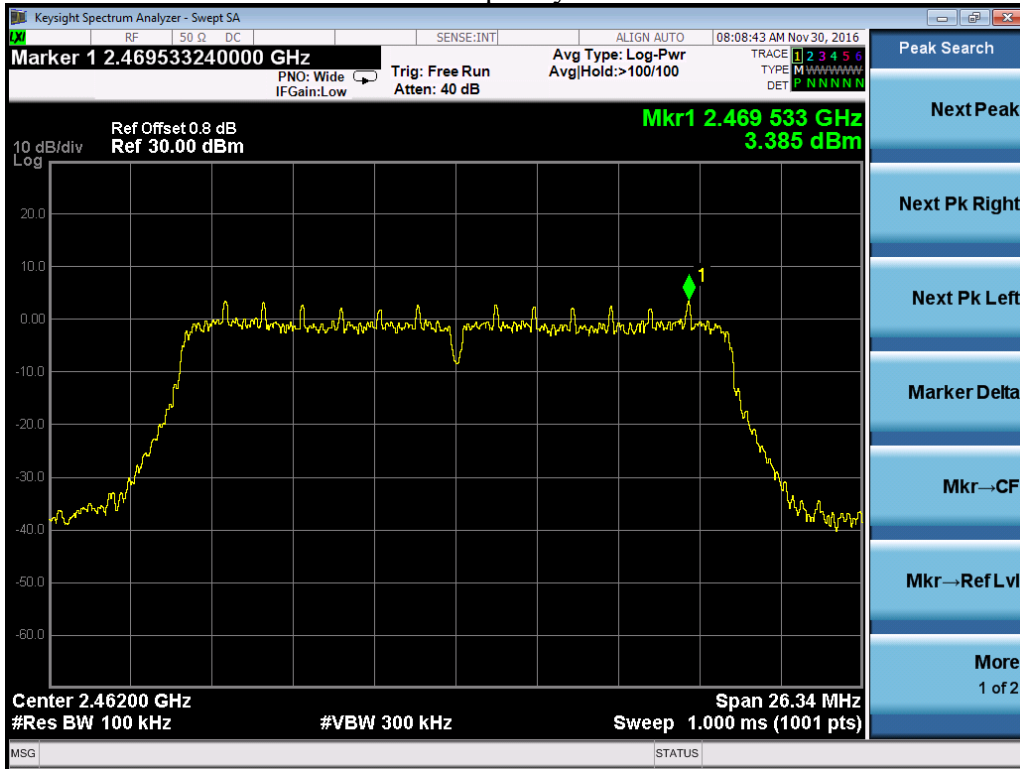

802.11n40
Frequency L

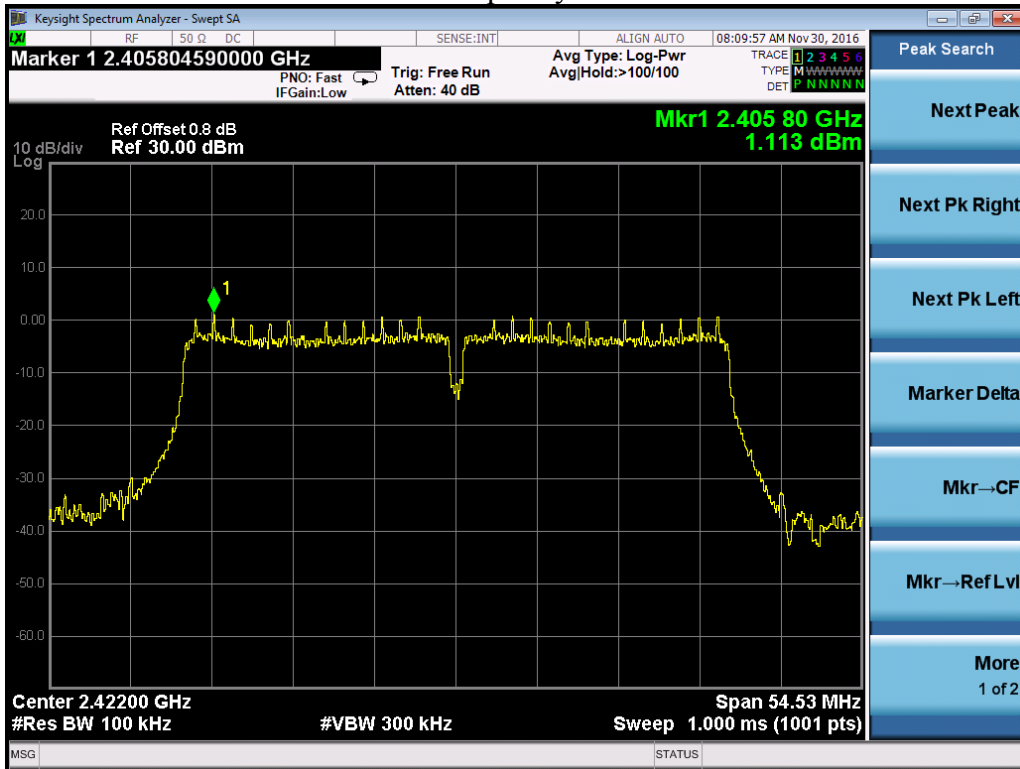

Frequency M

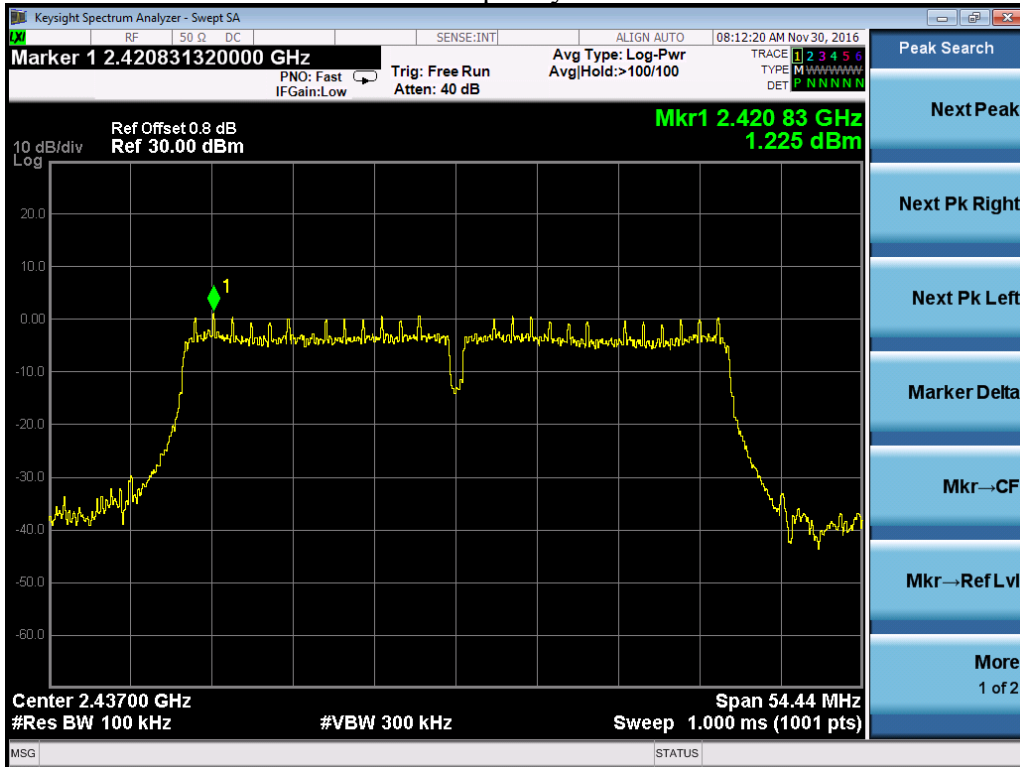

Frequency H

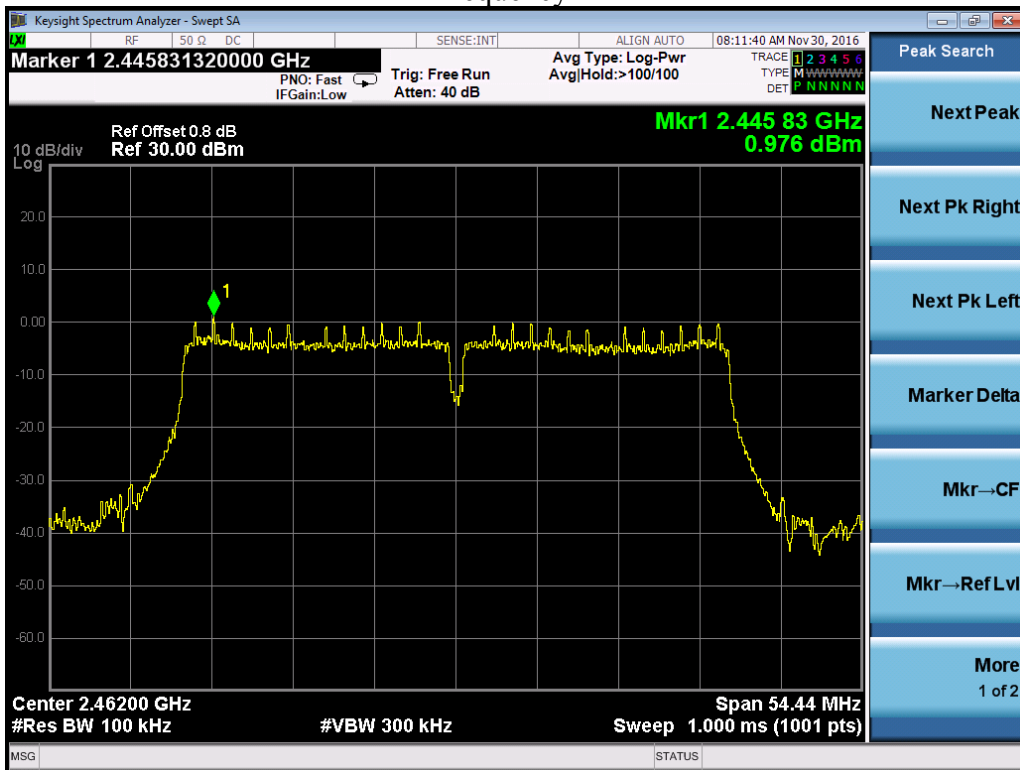

7. Emissions in non-restricted frequency bands

Test result: Pass

7.1 Test limit

In any 100 kHz bandwidth outside the frequency band in which the spread spectrum intentional radiator is operating, the radio frequency power that is produced by the intentional radiator shall be at least 20 dB below that in the 100 kHz bandwidth within the band that contains the highest level of the desired power.

7.2 Test Configuration

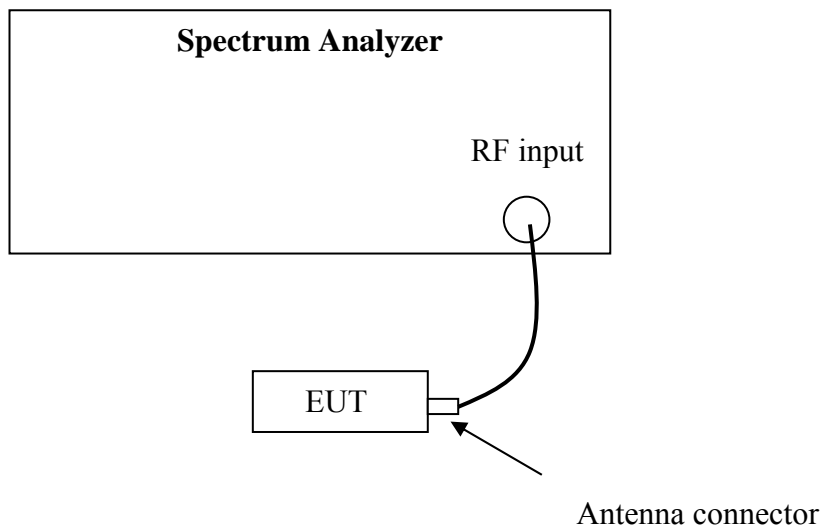

7.3 Test procedure and test setup

The Emission outside the frequency Band per FCC § 15.247(d) is measured using the Spectrum Analyzer with the resolutions bandwidth set at 100kHz, the video bandwidth set at 300kHz, and the SPAN>>RBW.

The EUT was tested according to DTS test procedure of “KDB558074 D01 DTS Meas Guidance v03r05” (clause 11.0) for compliance to FCC 47CFR 15.247 requirements.

7.4 Test Protocol

Temperature: 22 °C

Relative Humidity: 53 %

Test Mode	Frequency (MHz)	Results		Limit
		Port 1	Port 2	
802.11b	2412	Pass	Pass	>20dB
	2437	Pass	Pass	
	2462	Pass	Pass	
802.11g	2412	Pass	Pass	
	2437	Pass	Pass	
	2462	Pass	Pass	
802.11n20	2412	Pass	Pass	
	2437	Pass	Pass	
	2462	Pass	Pass	
802.11n40	2422	Pass	Pass	
	2437	Pass	Pass	
	2452	Pass	Pass	

Test plot as follows:

802.11b
Frequency L

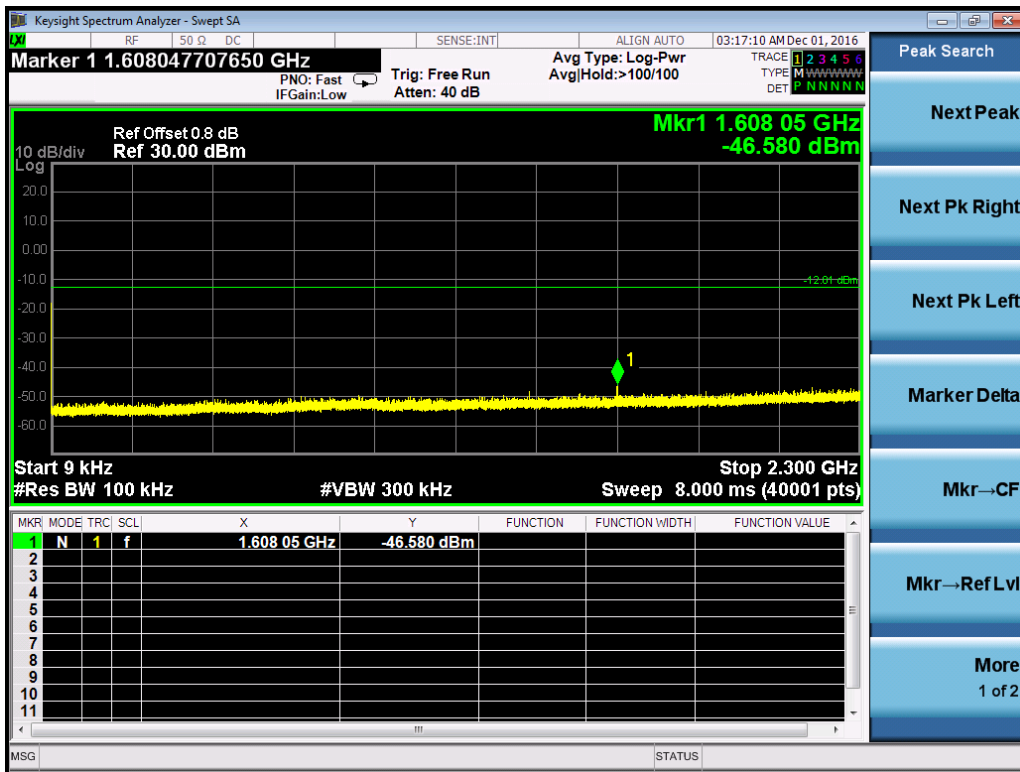
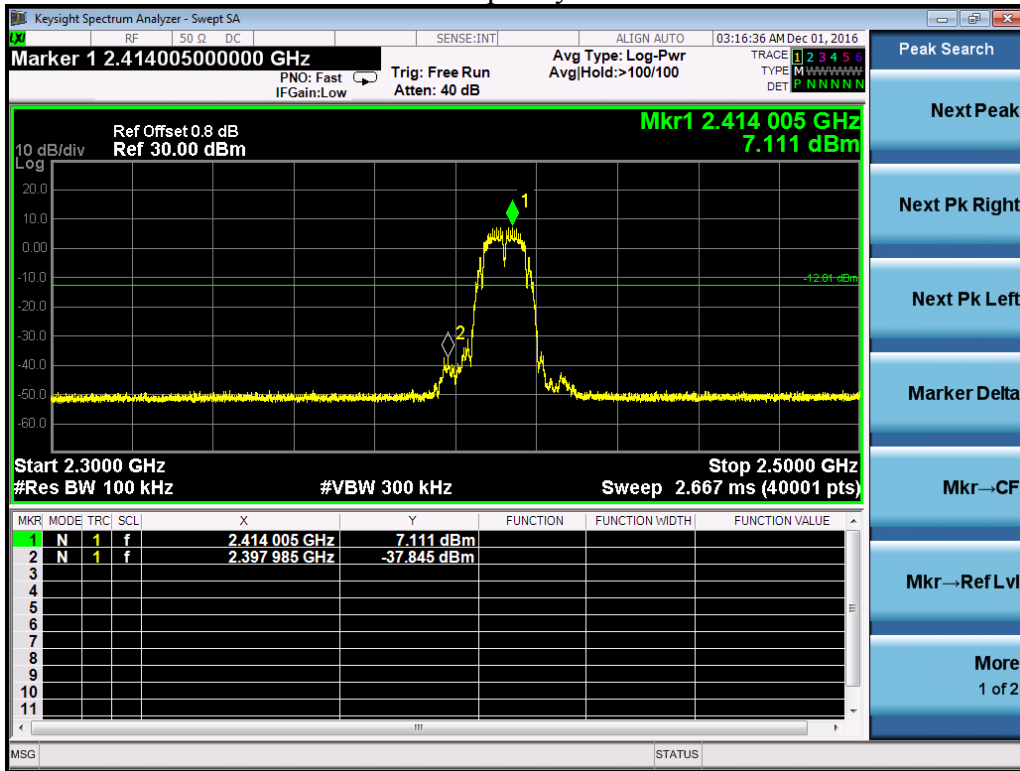

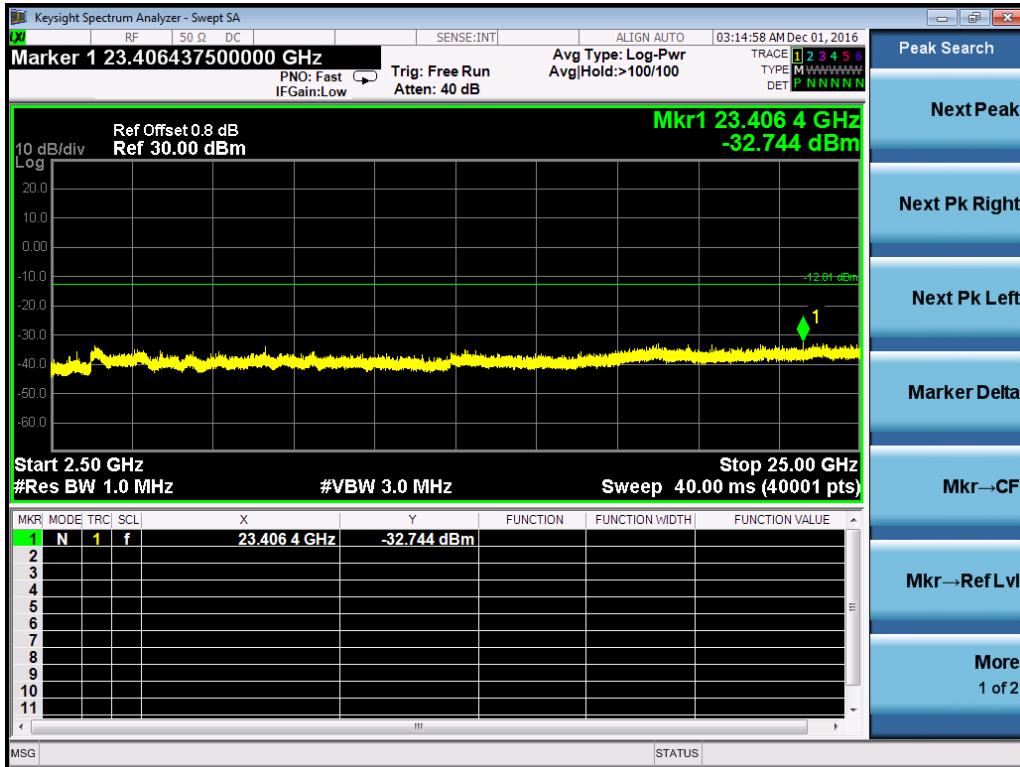

Frequency M

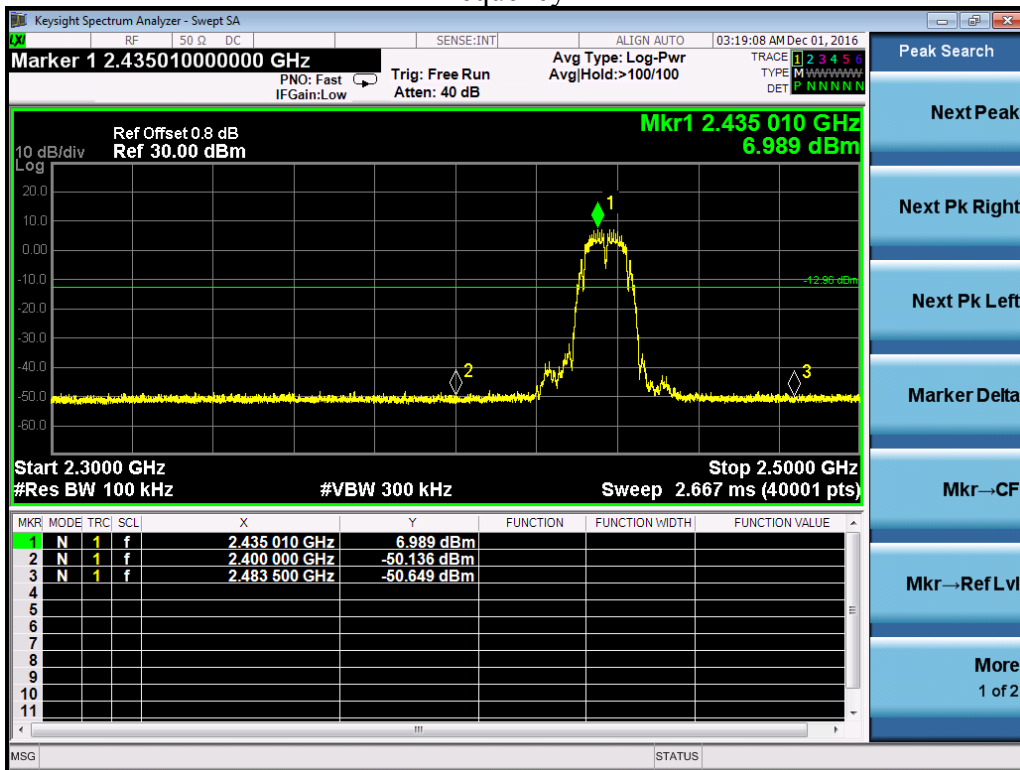

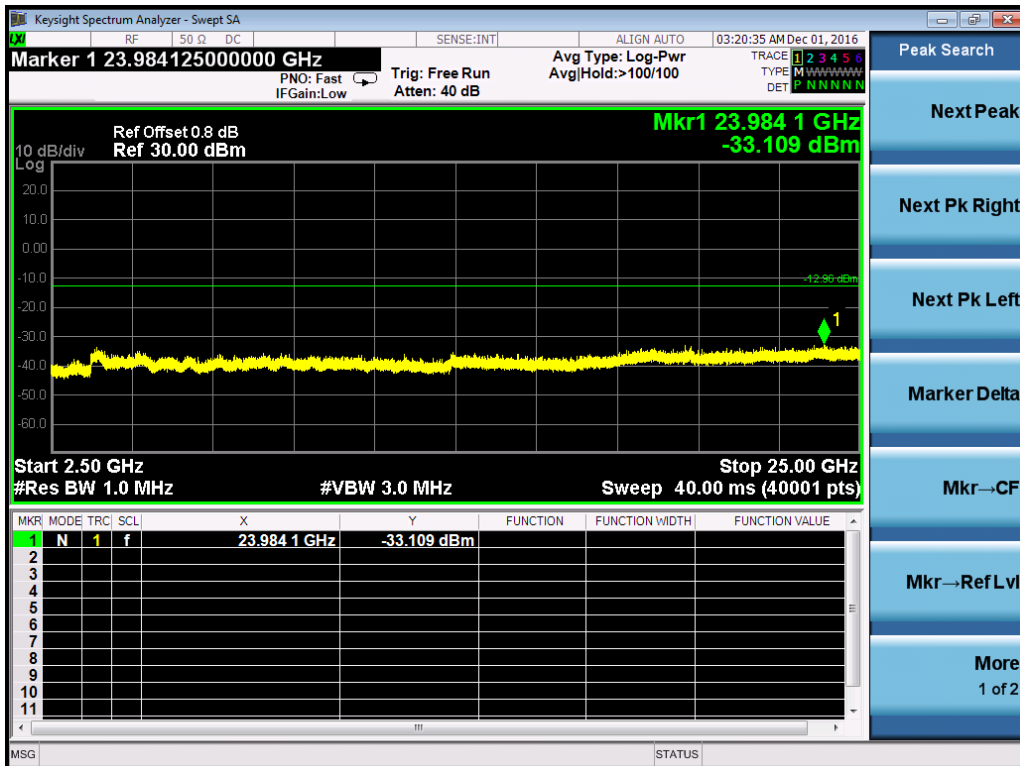
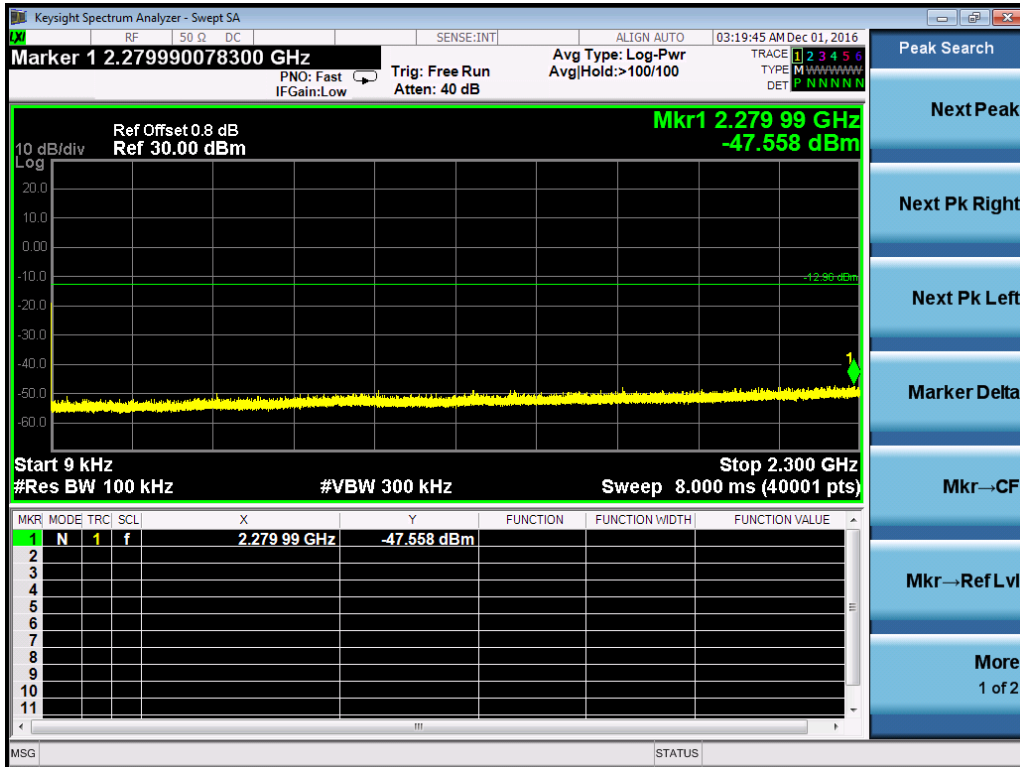

Frequency H

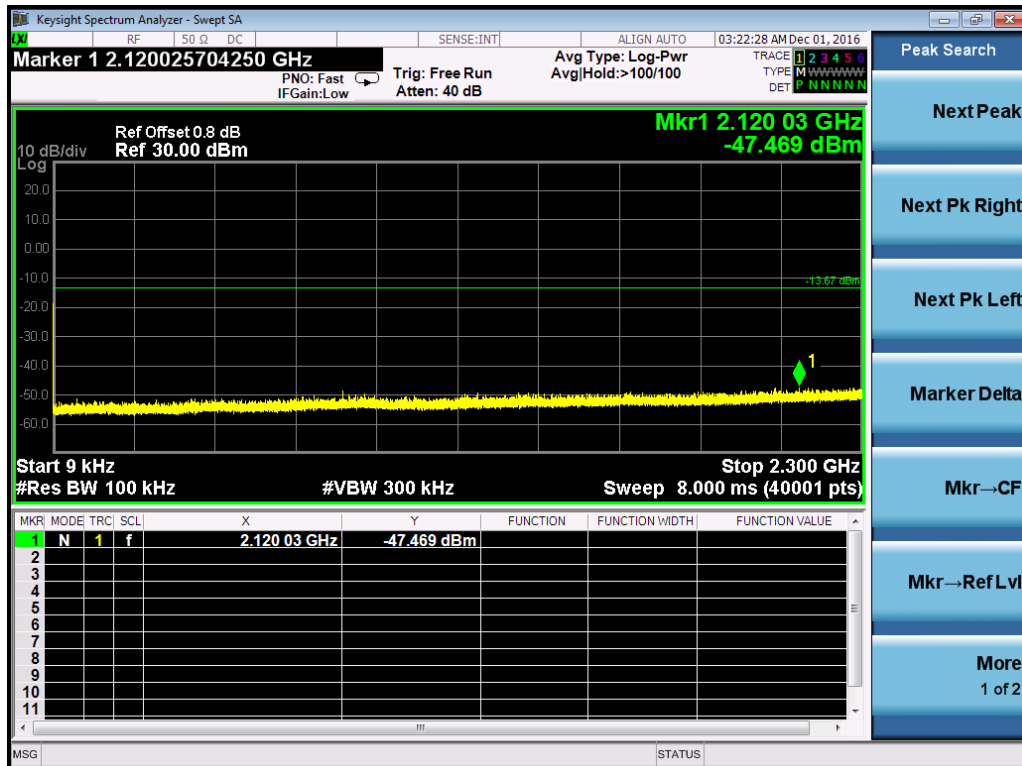
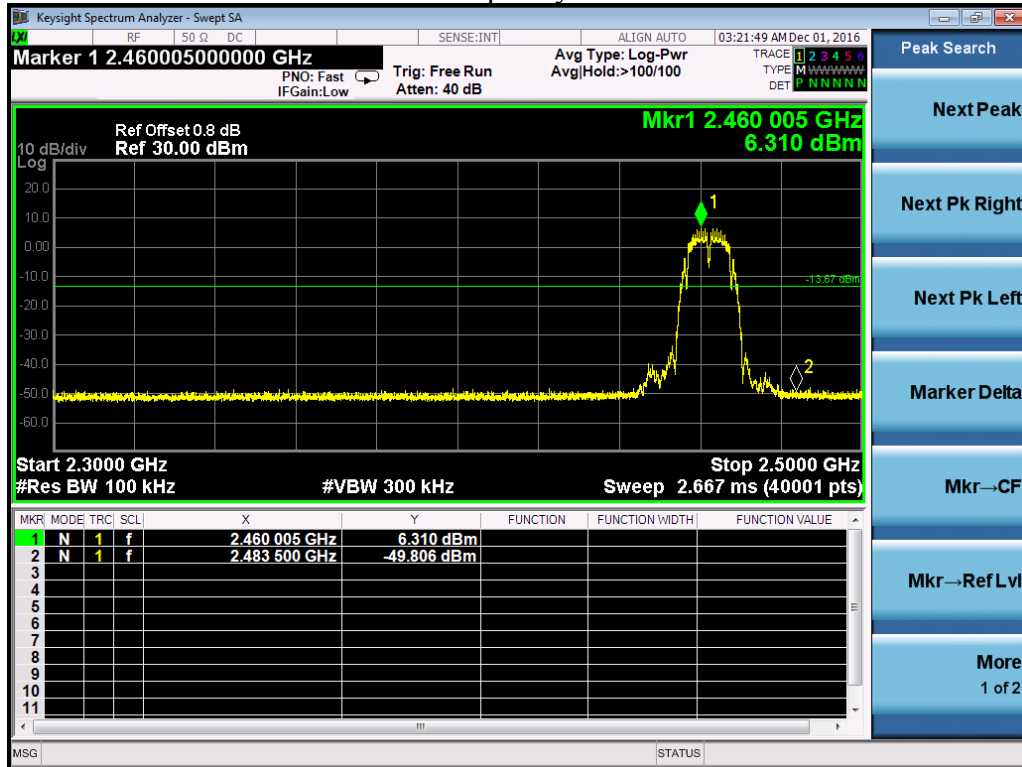

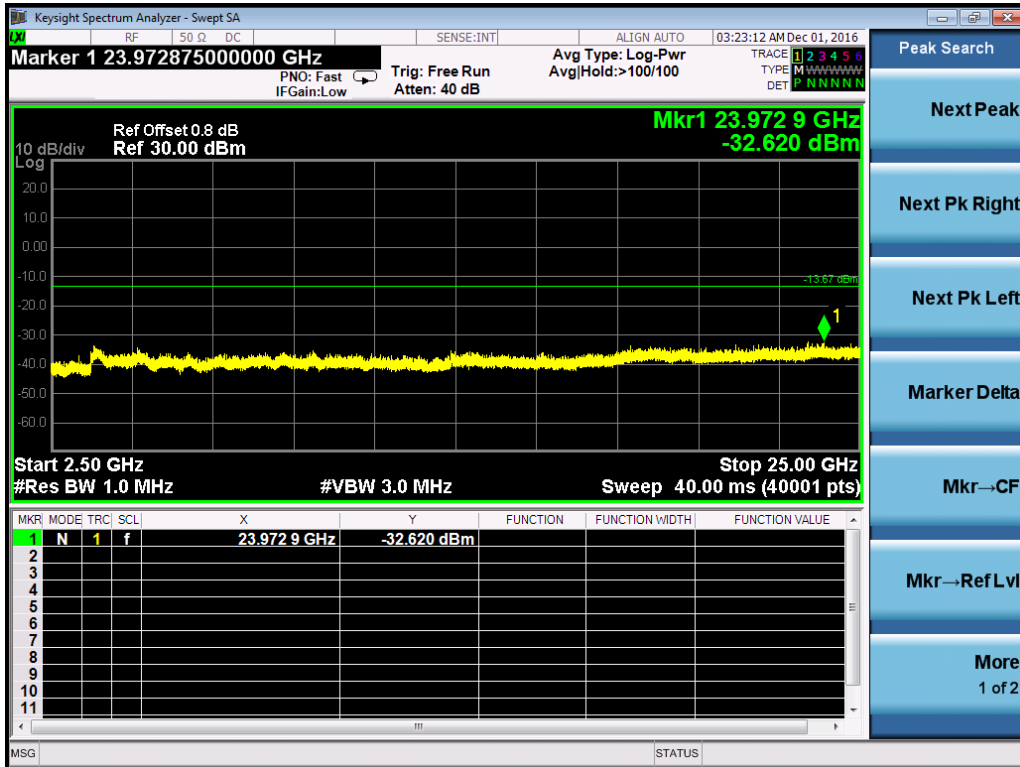

802.11g Frequency L

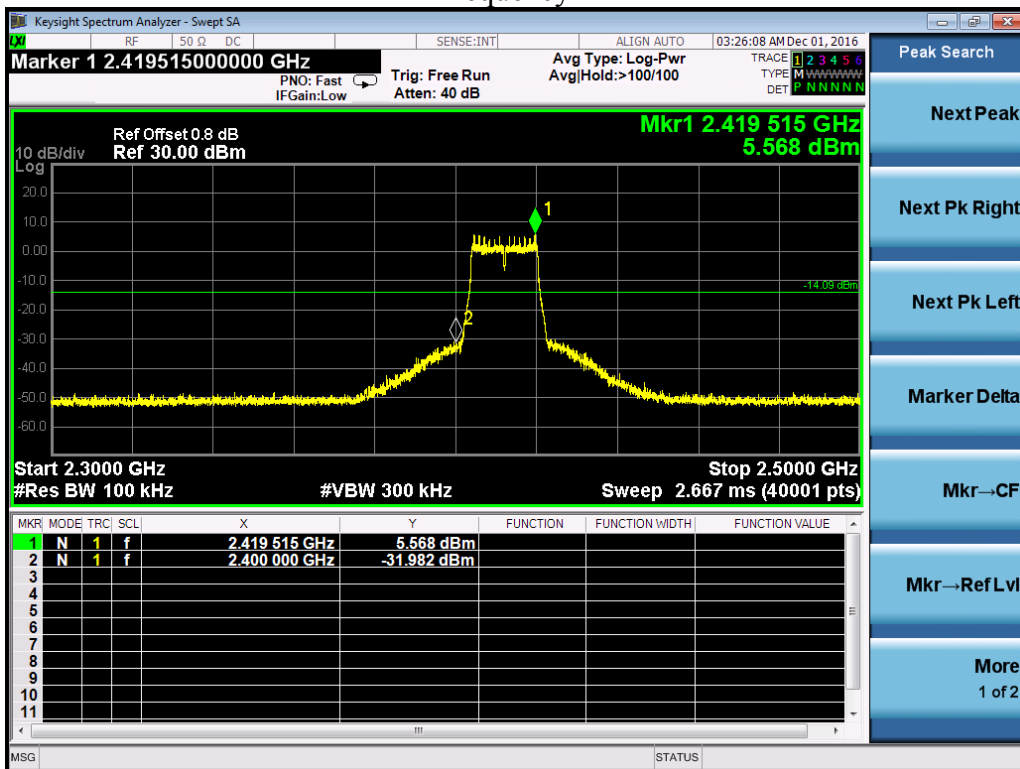

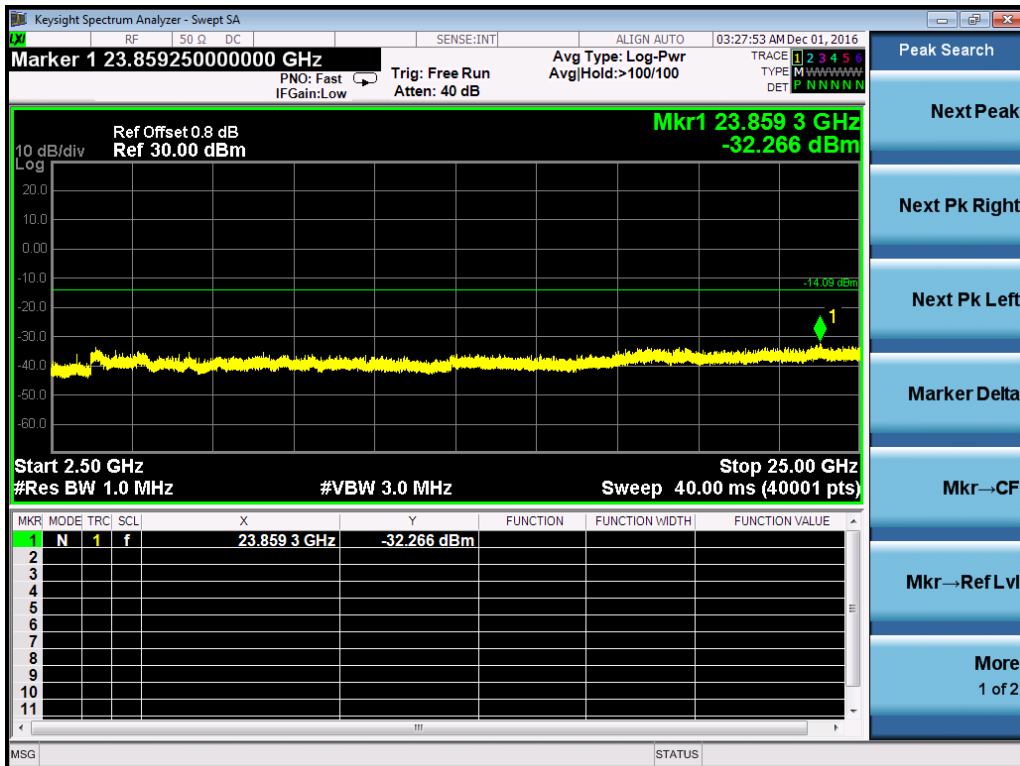
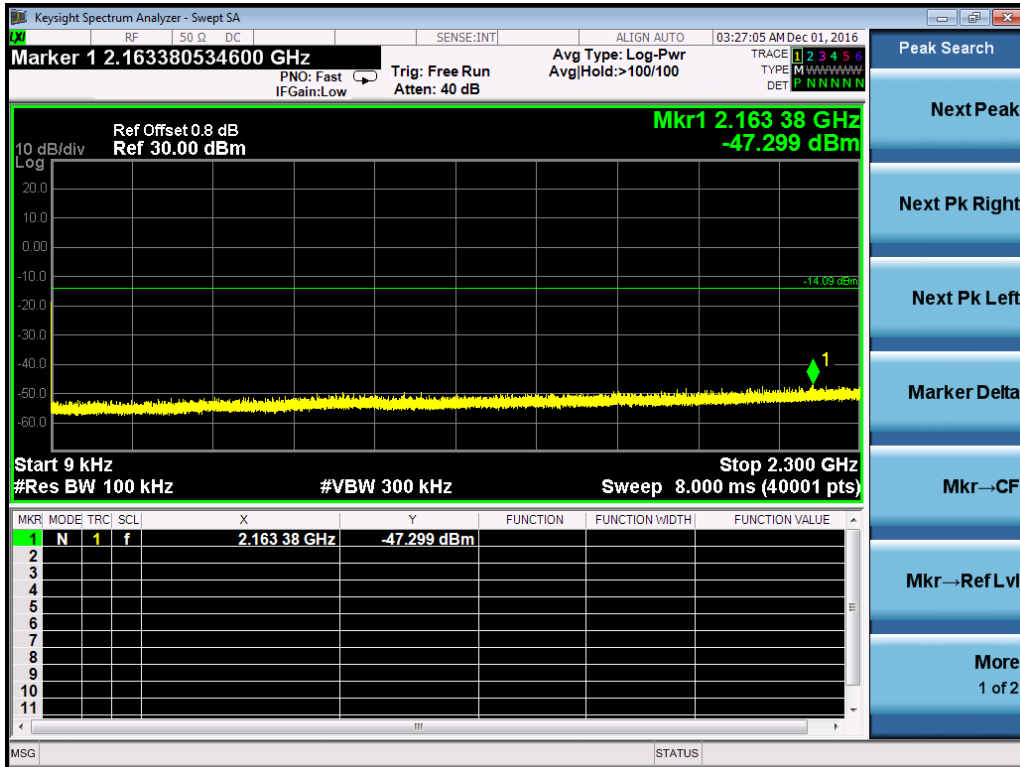

Frequency M

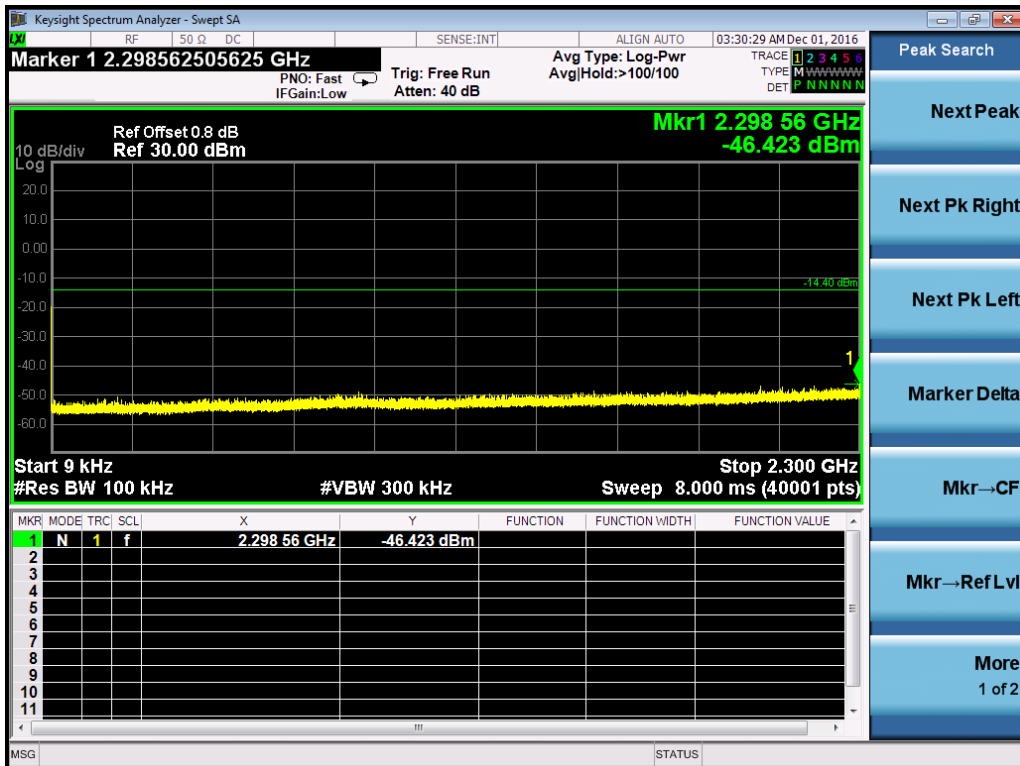
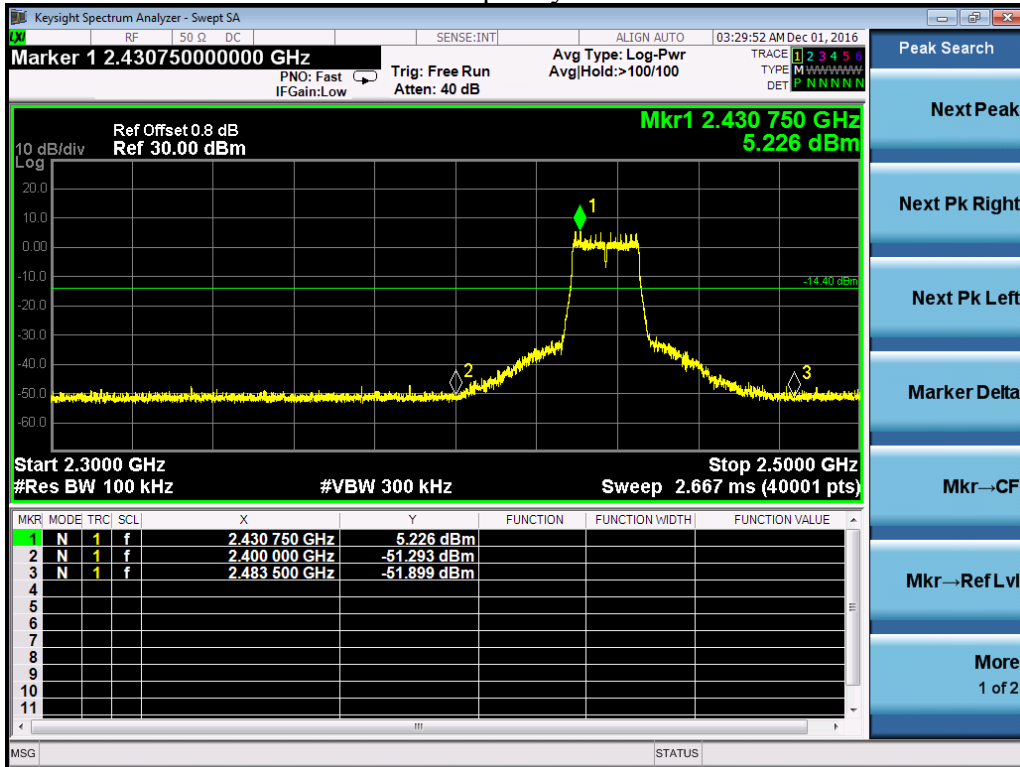

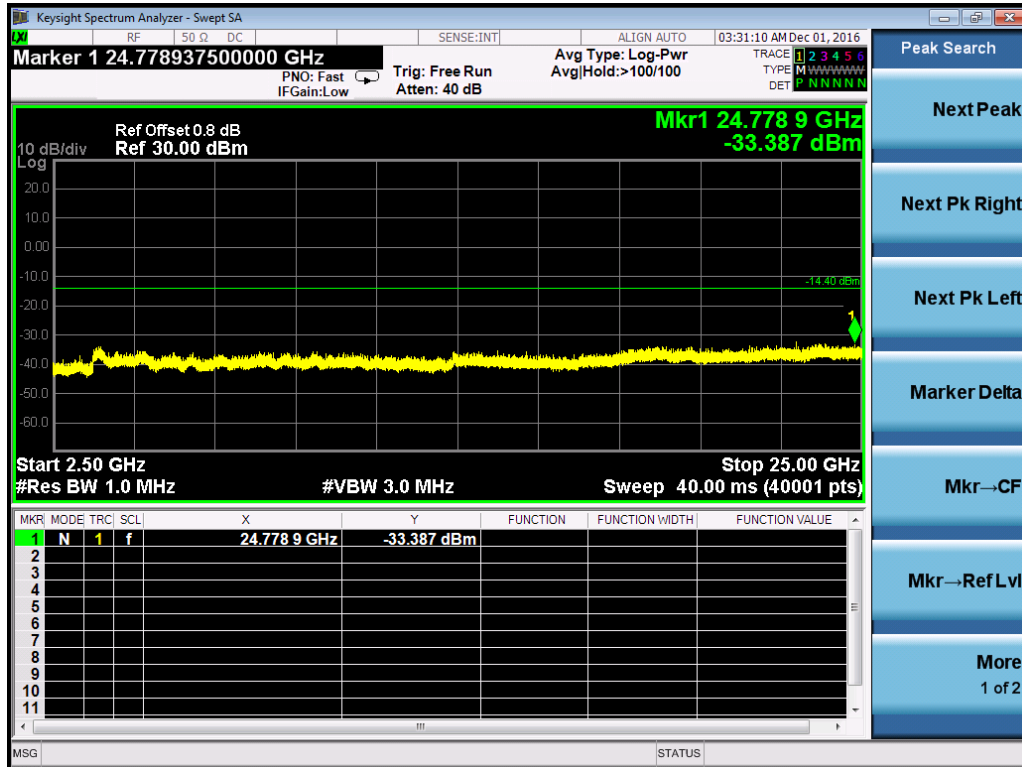

Frequency H

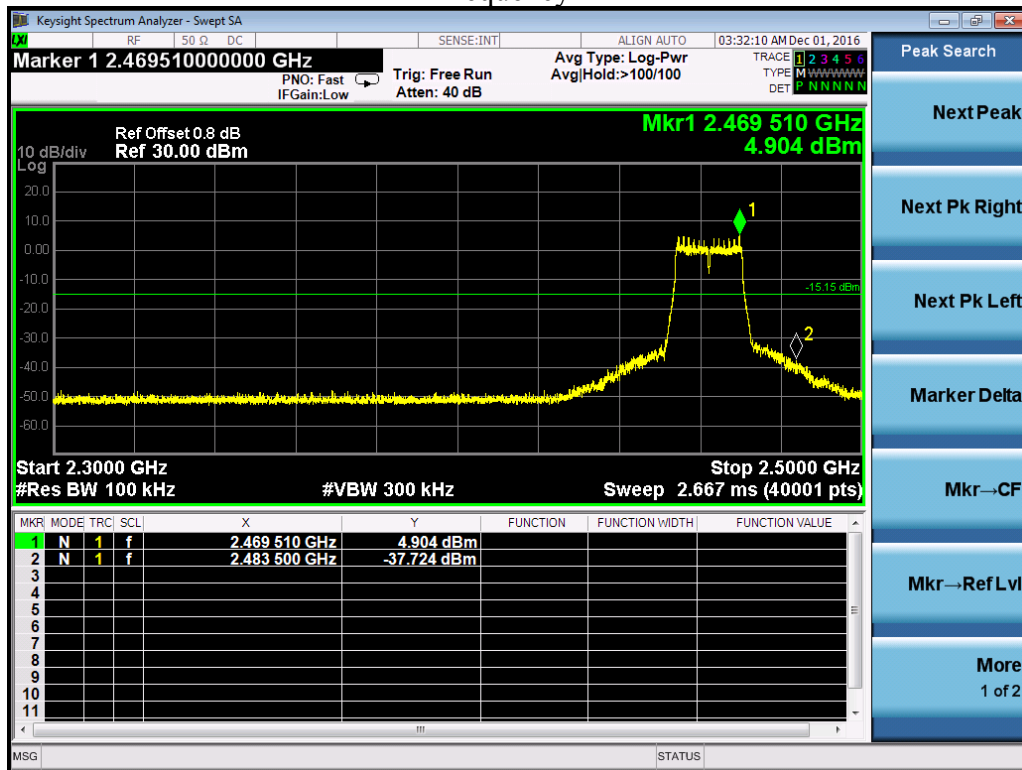

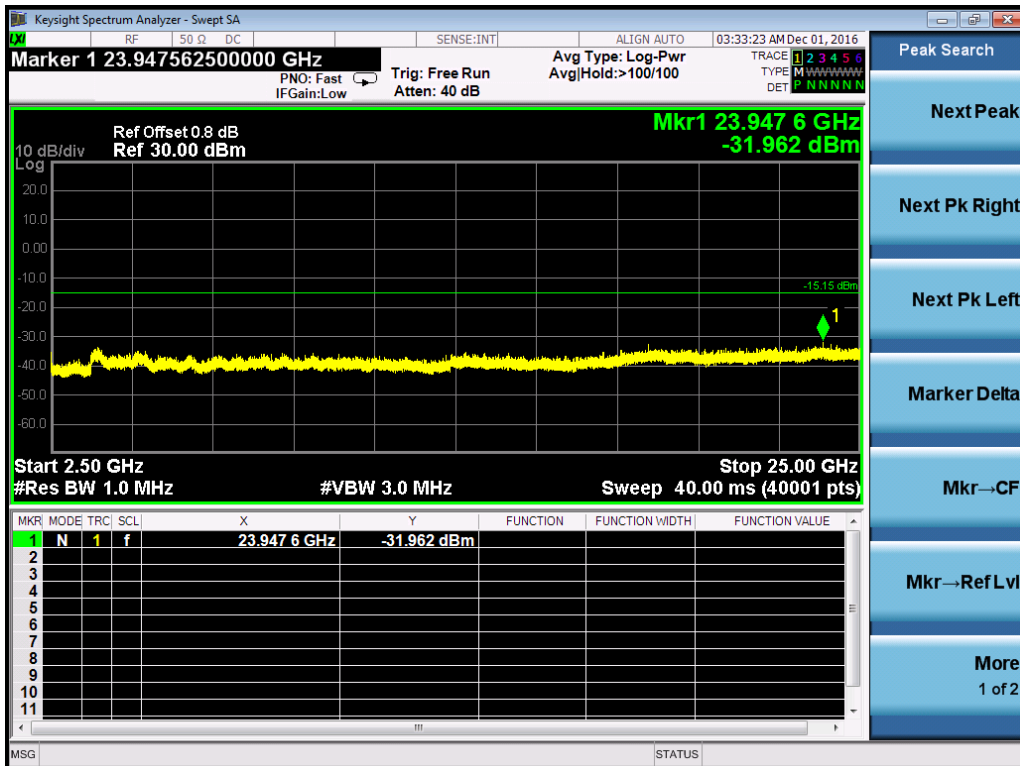
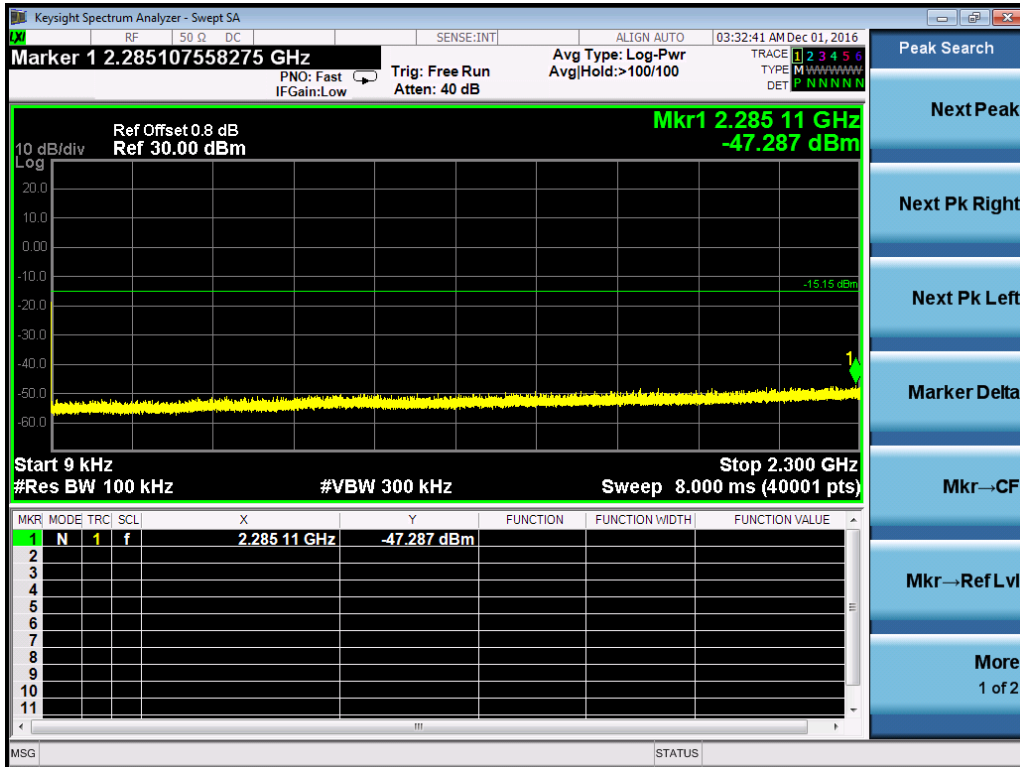

802.11n20
Frequency L

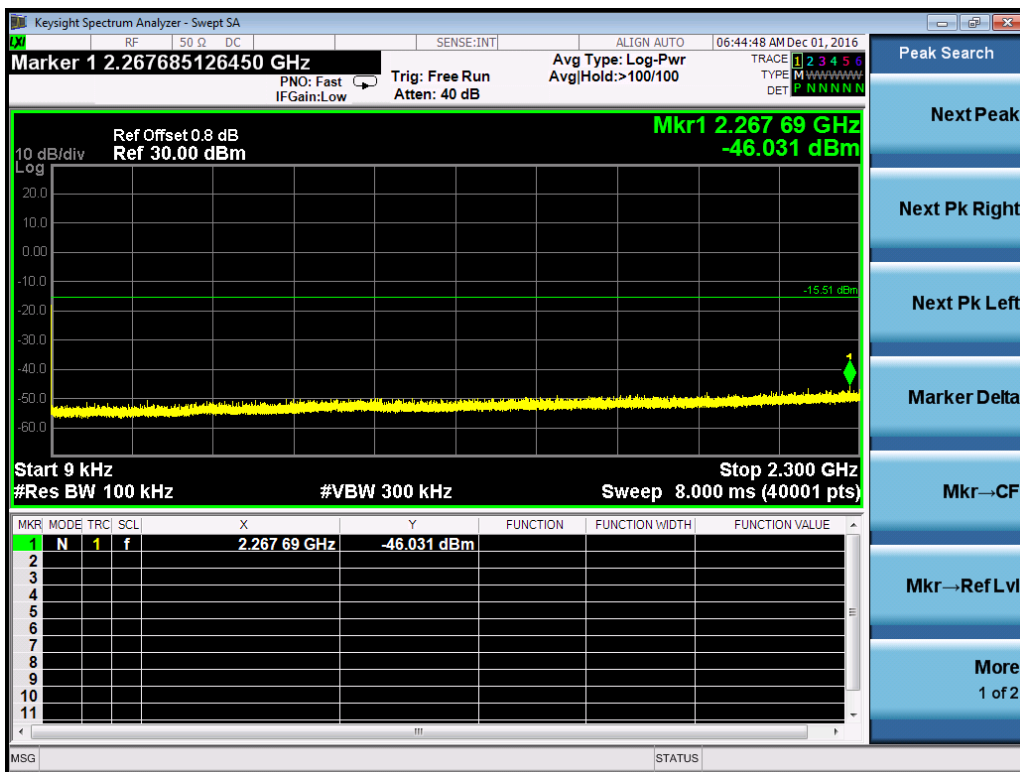
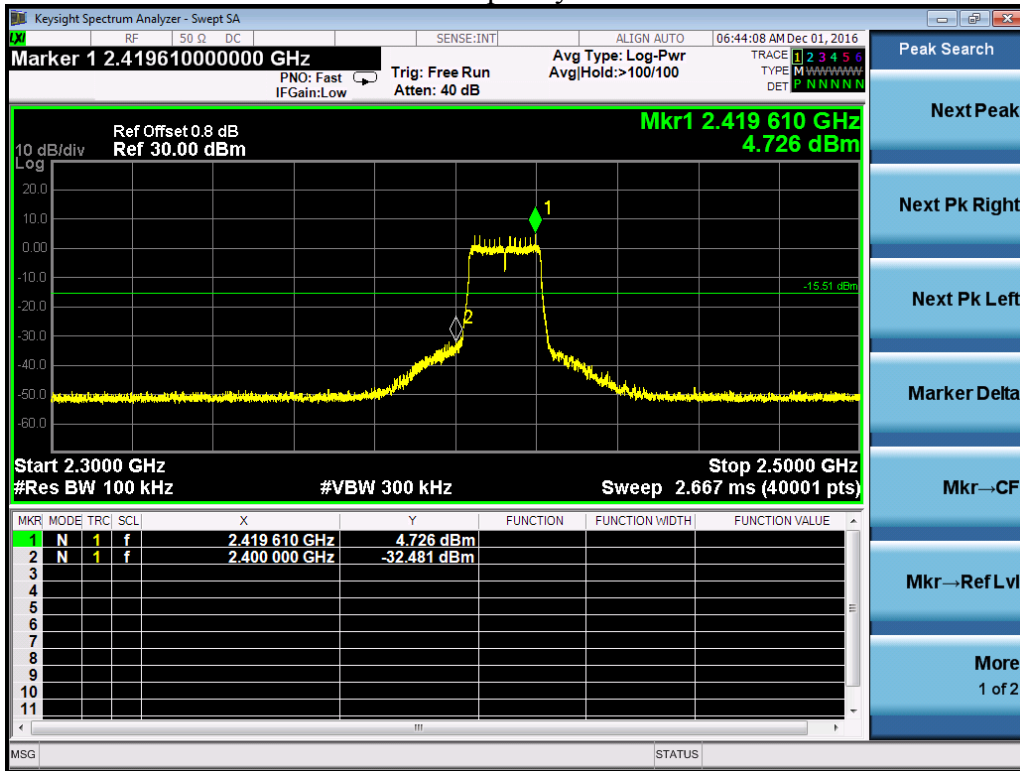

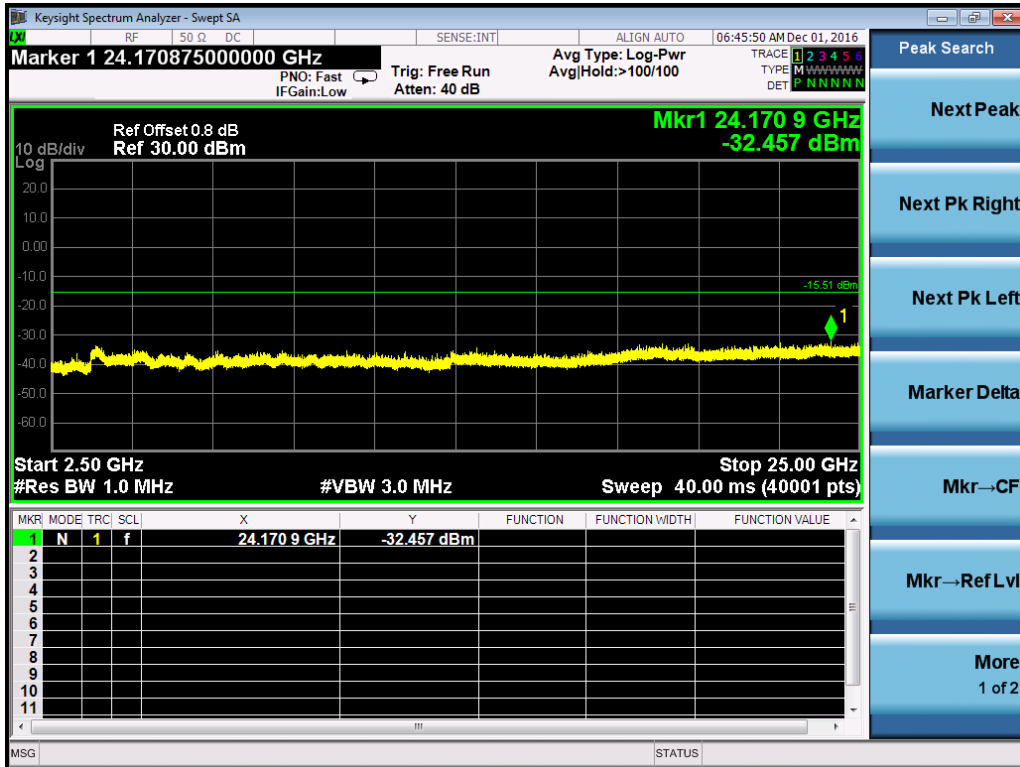

Frequency M

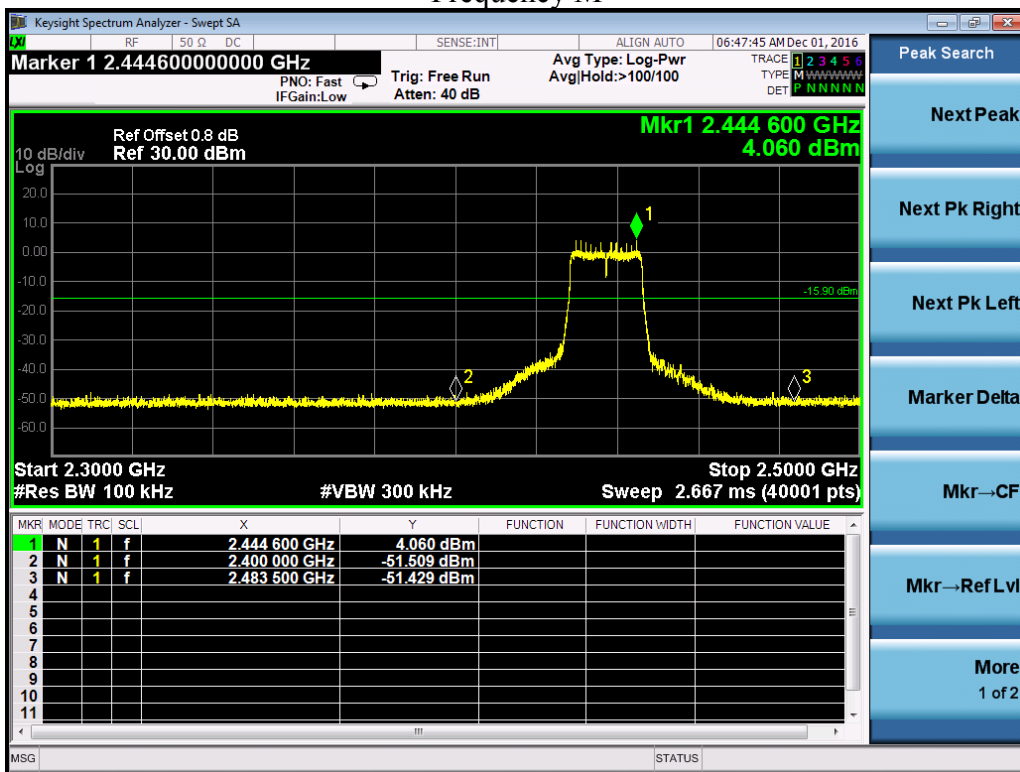

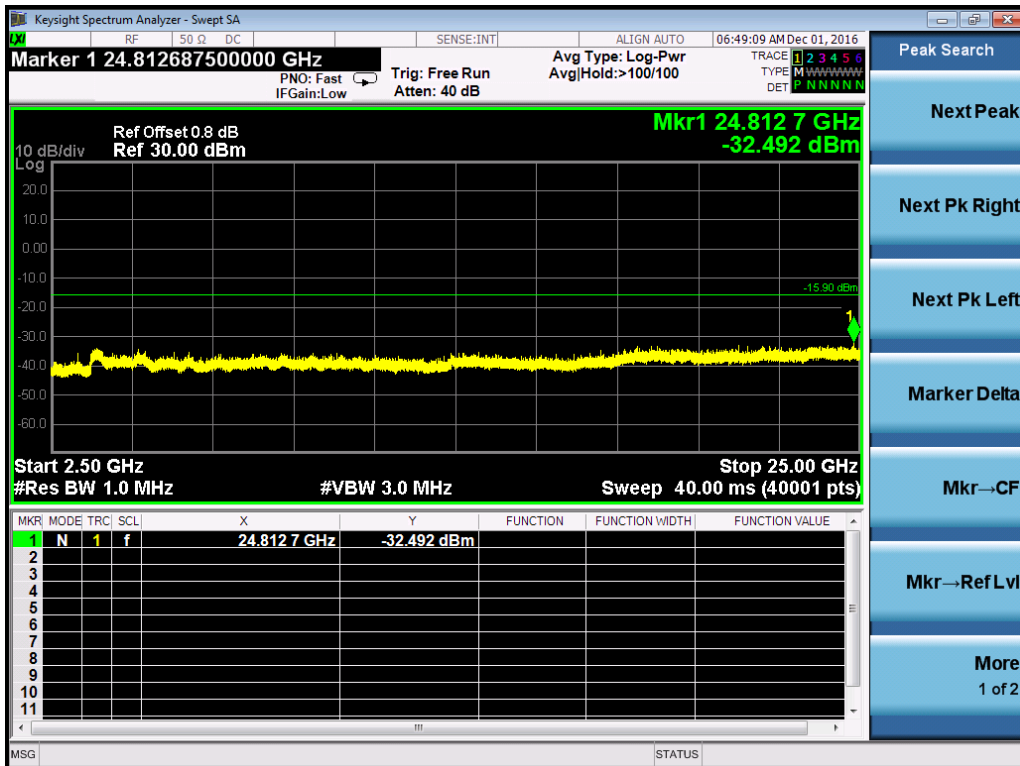
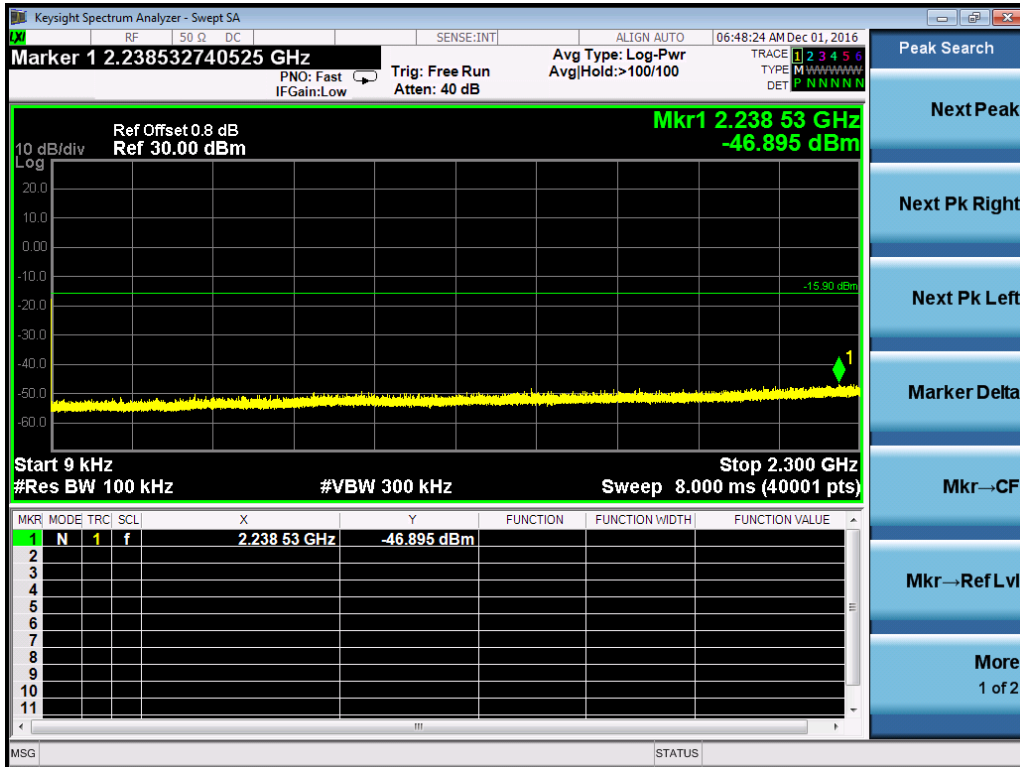

Frequency H

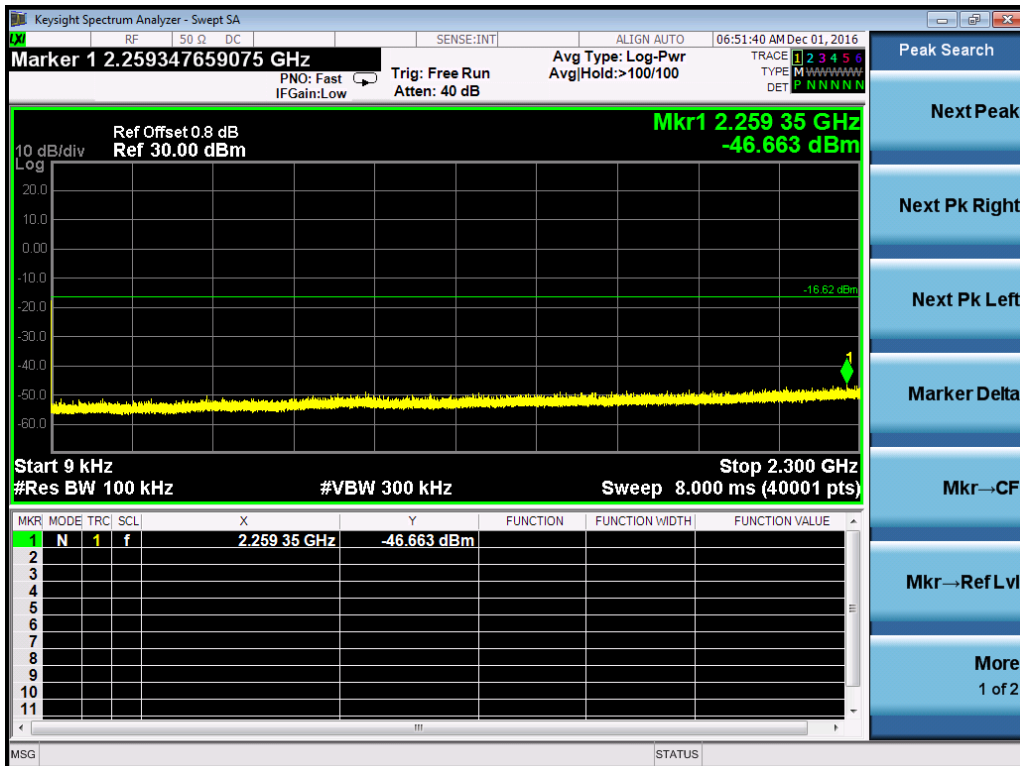
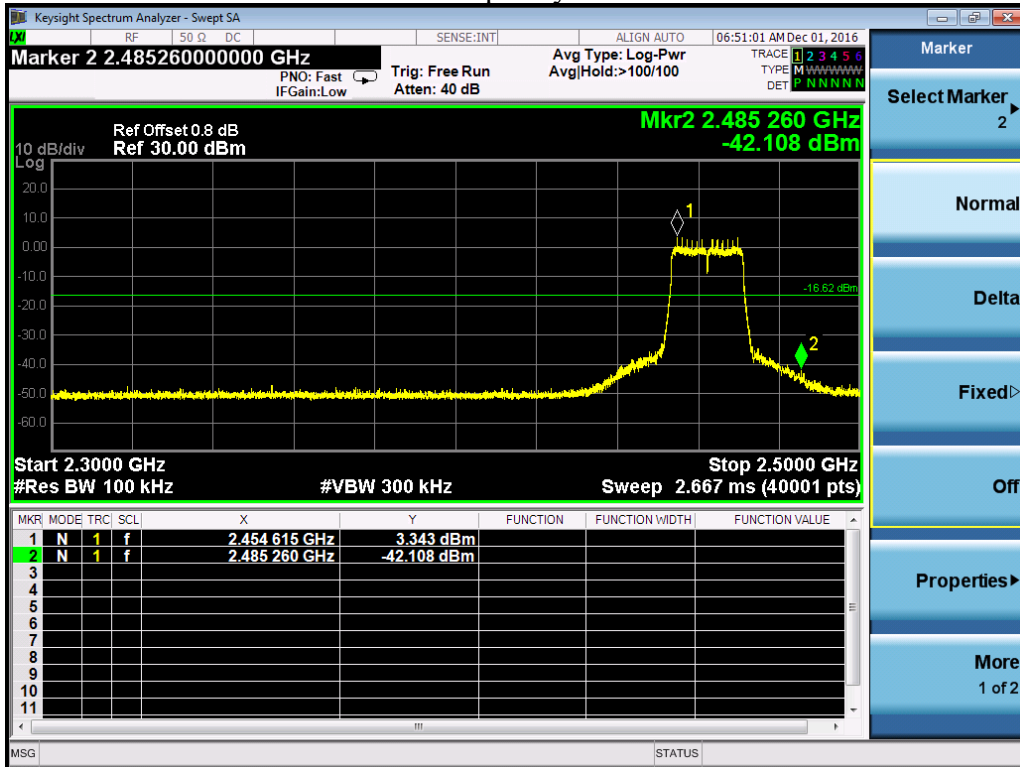

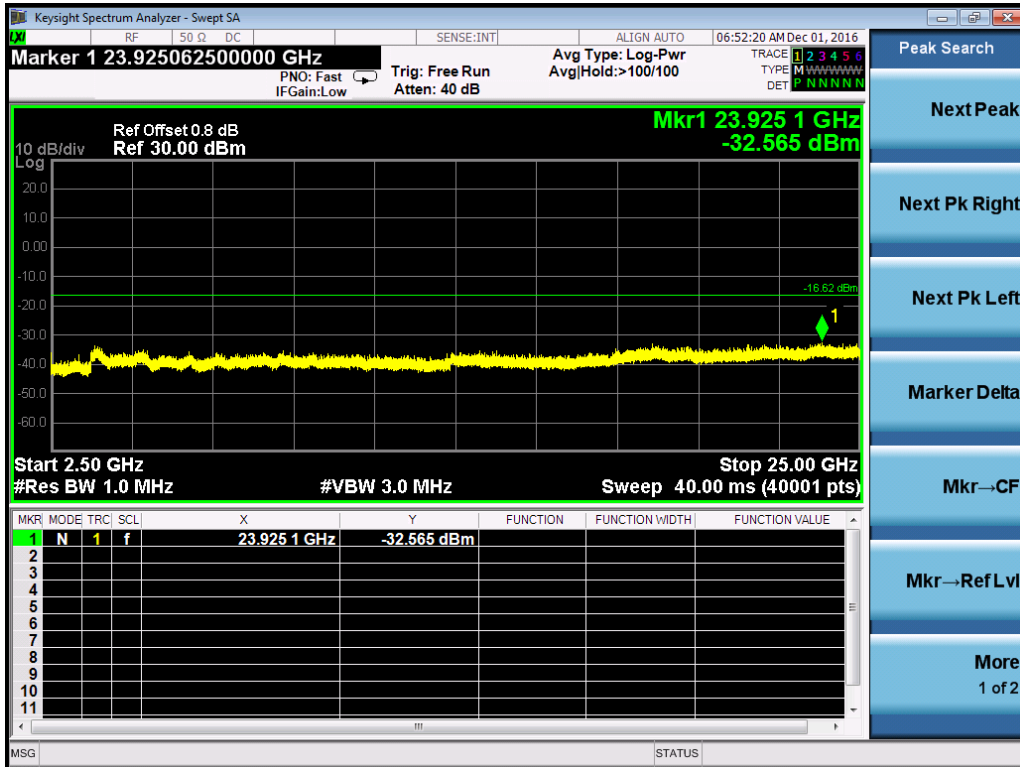

802.11n40
Frequency L

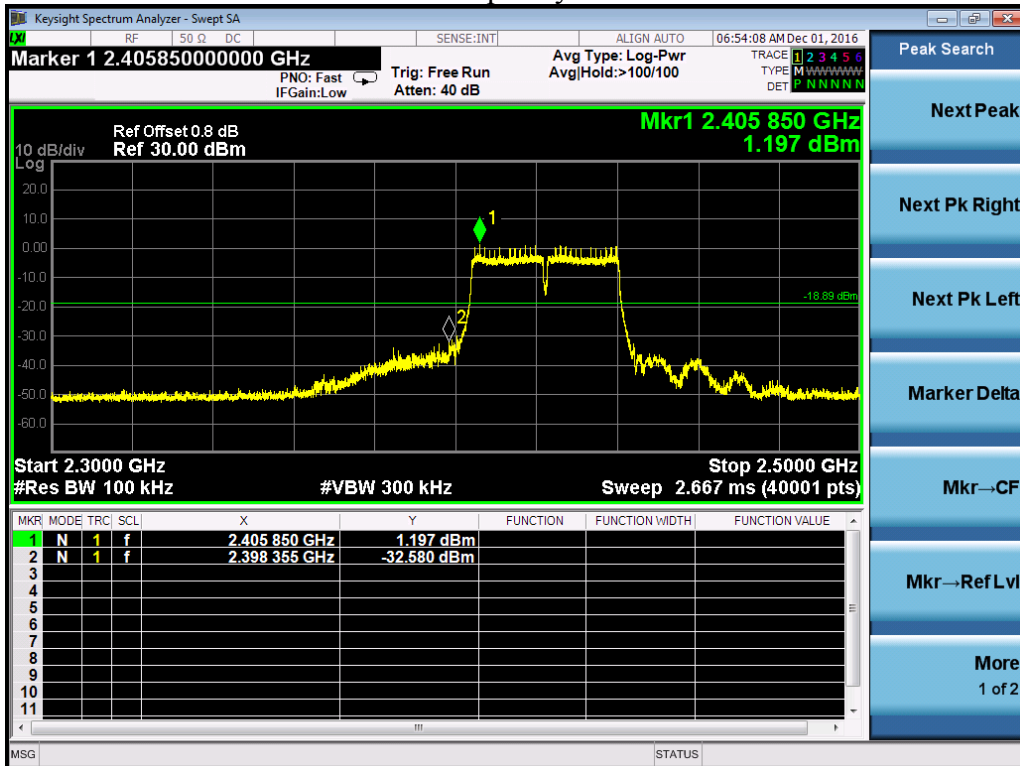

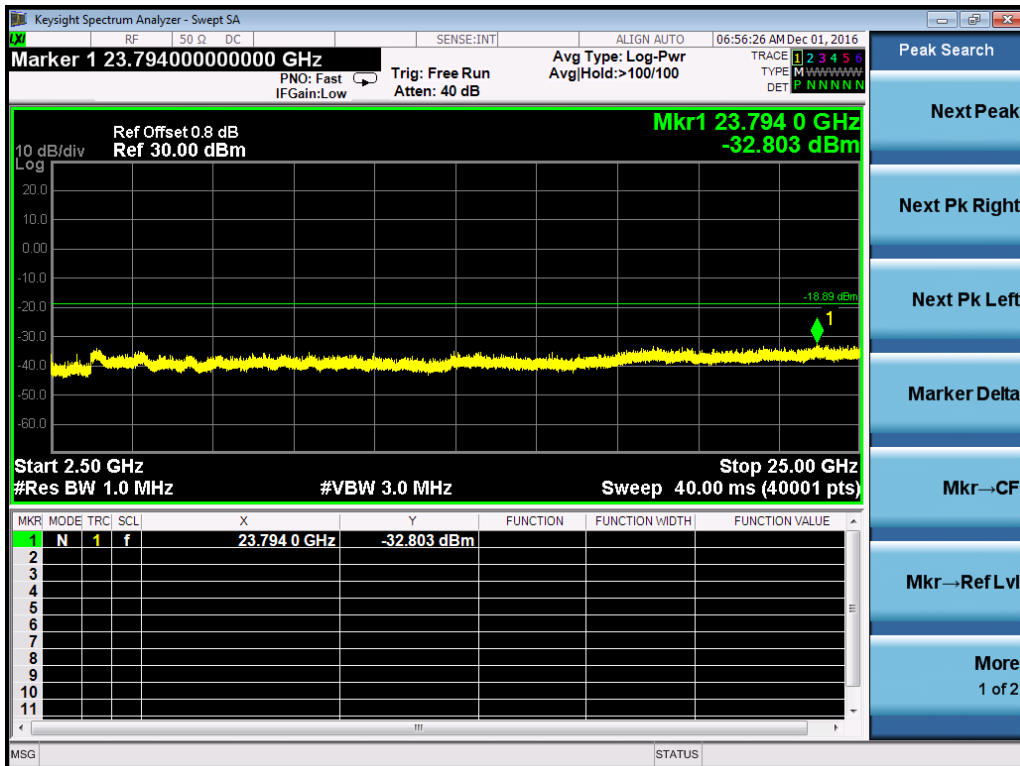
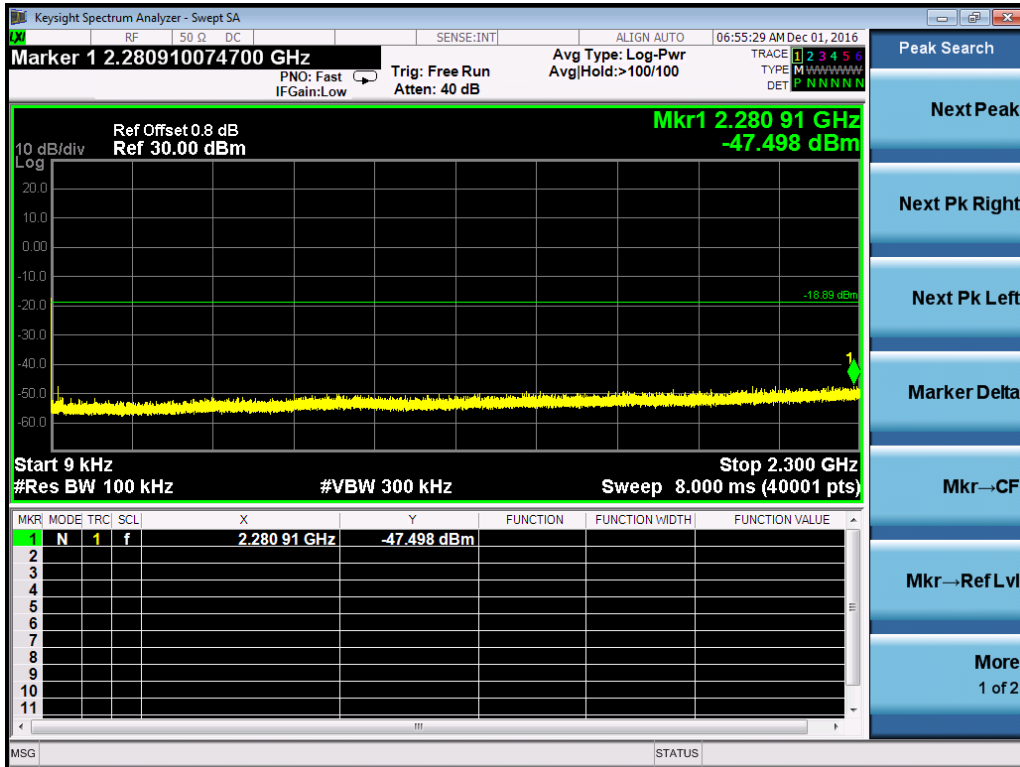

Frequency M

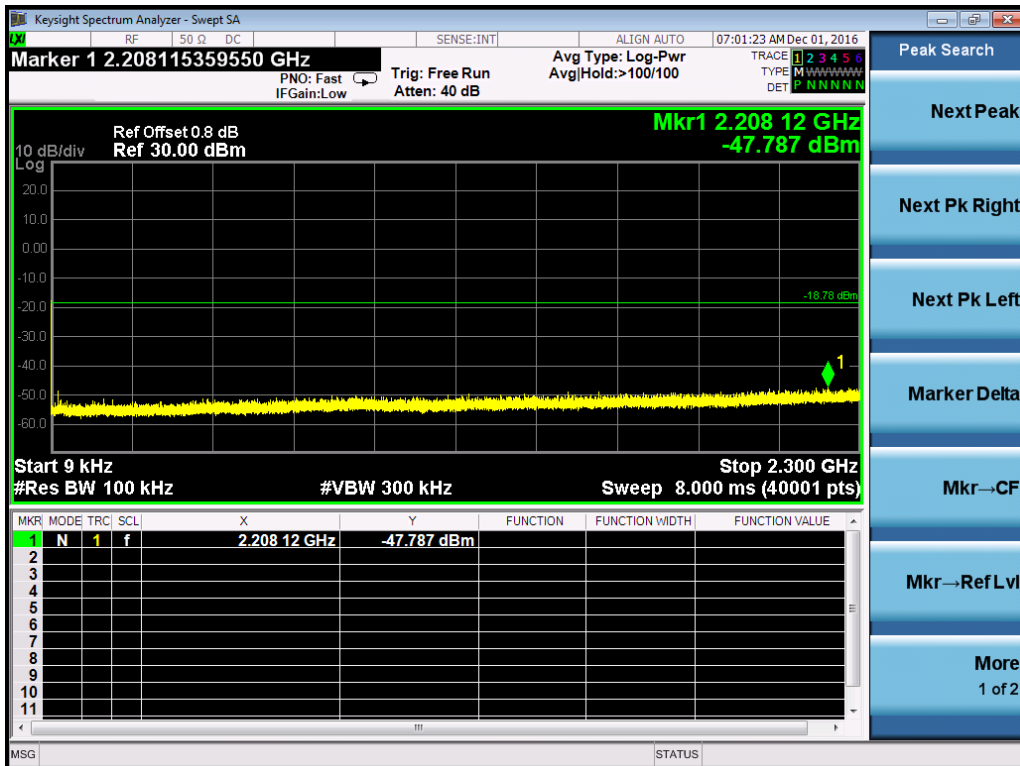
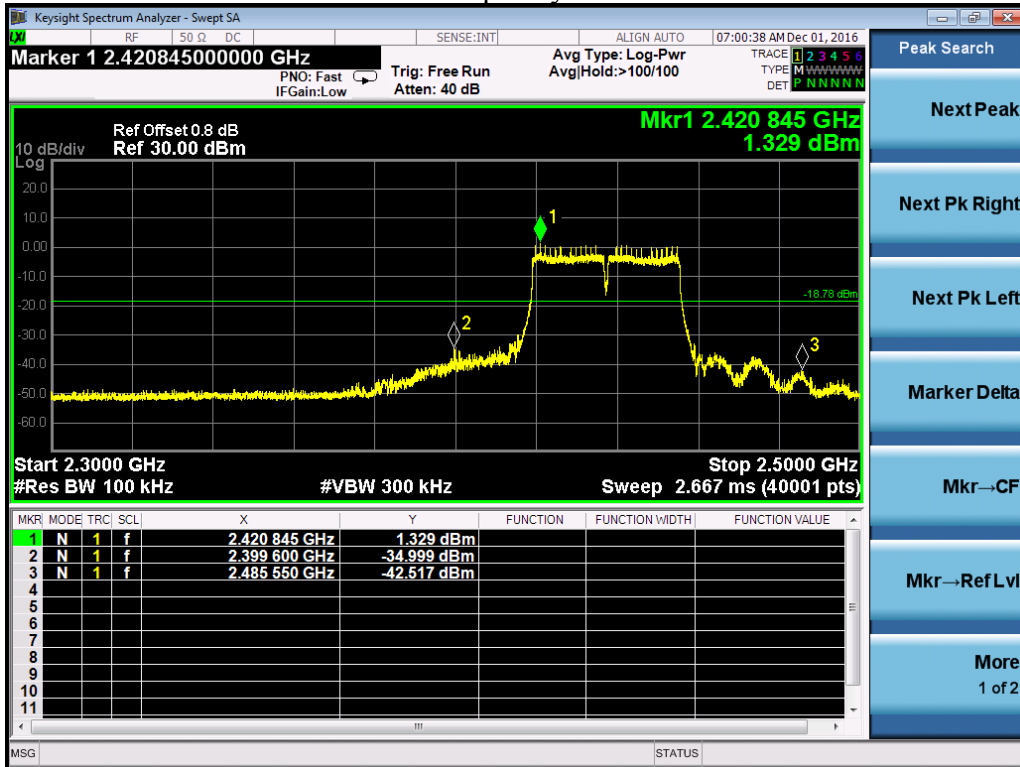

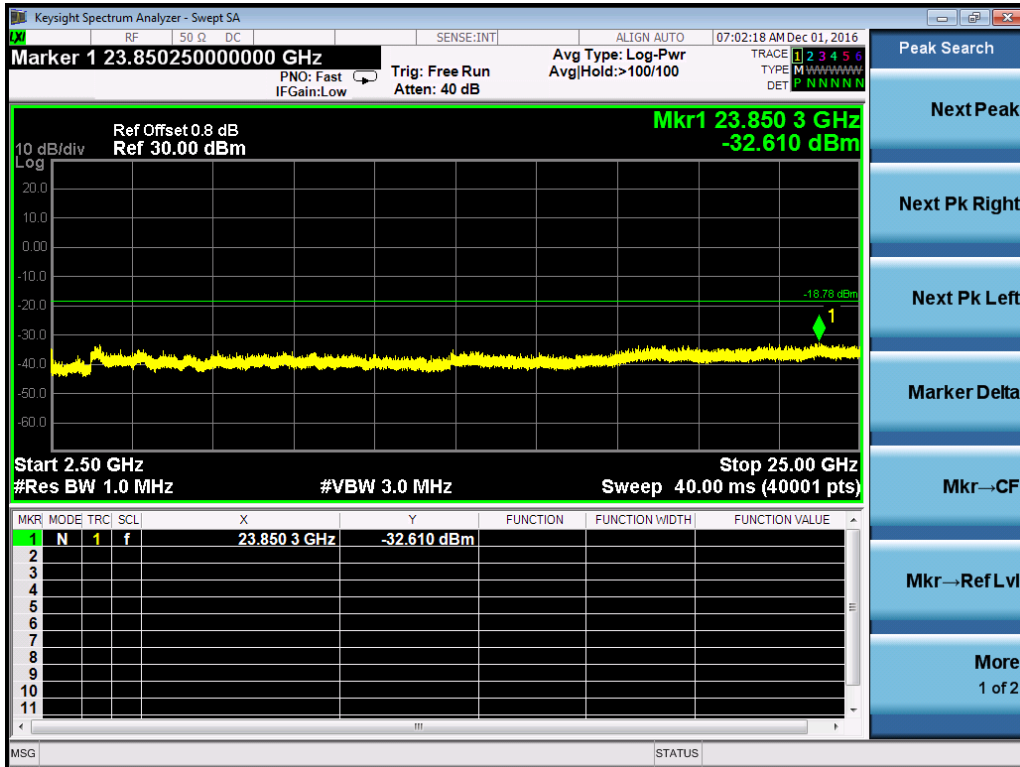

Frequency H

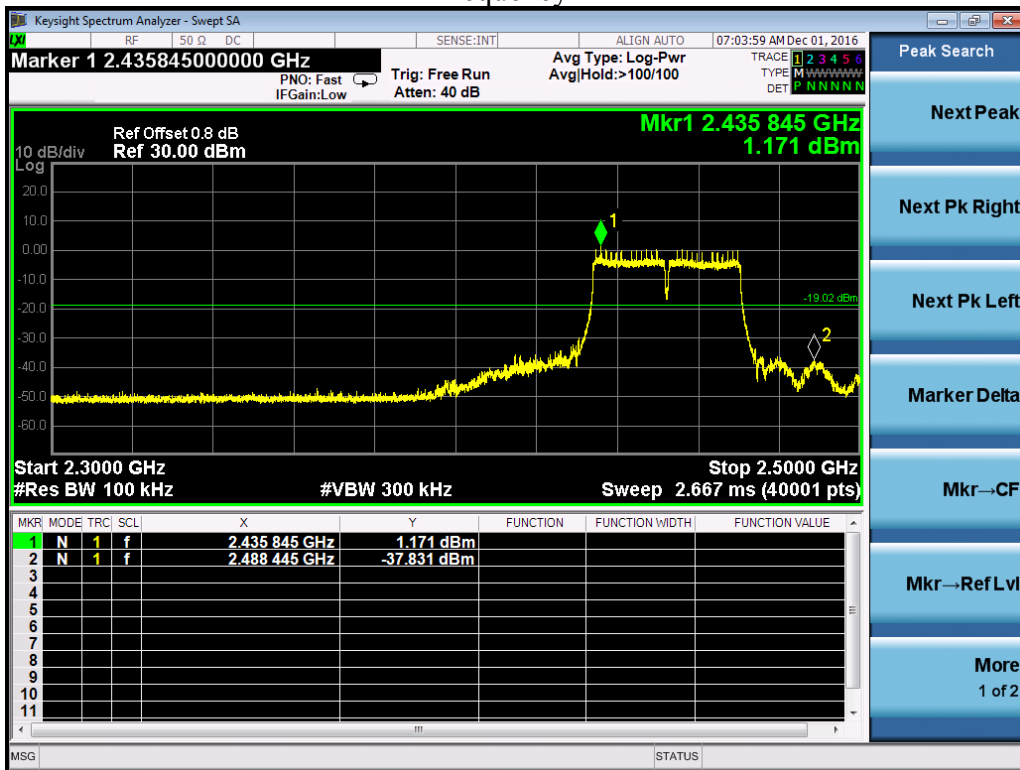

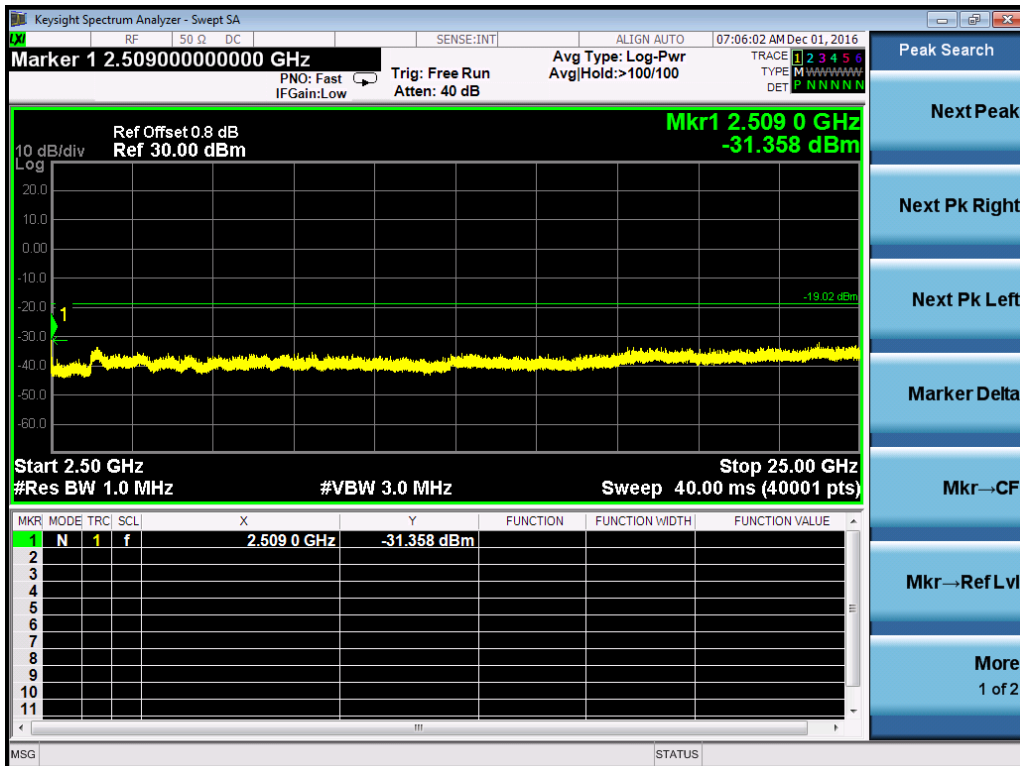
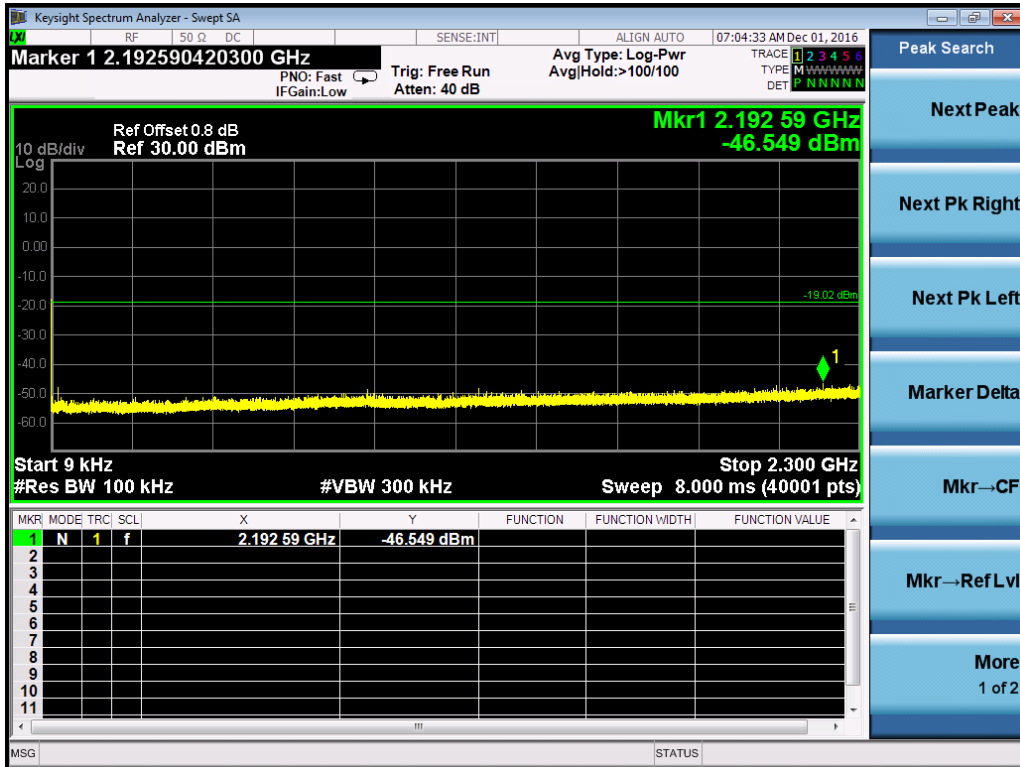

8. Radiated Emissions in restricted frequency bands

Test result: Pass

8.1 Test limit

The radiated emissions which fall in the restricted bands, as defined in § 15.205(a), must also comply with the radiated emission limits specified in § 15.209(a) showed as below:

Frequencies (MHz)	Field Strength (microvolts/meter)	Measurement Distance (meters)
0.009 ~ 0.490	2400/F(kHz)	300
0.490 ~ 1.705	24000/F(kHz)	30
1.705 ~ 30.0	30	30
30 ~ 88	100	3
88 ~ 216	150	3
216 ~ 960	200	3
Above 960	500	3

8.2 Test Configuration

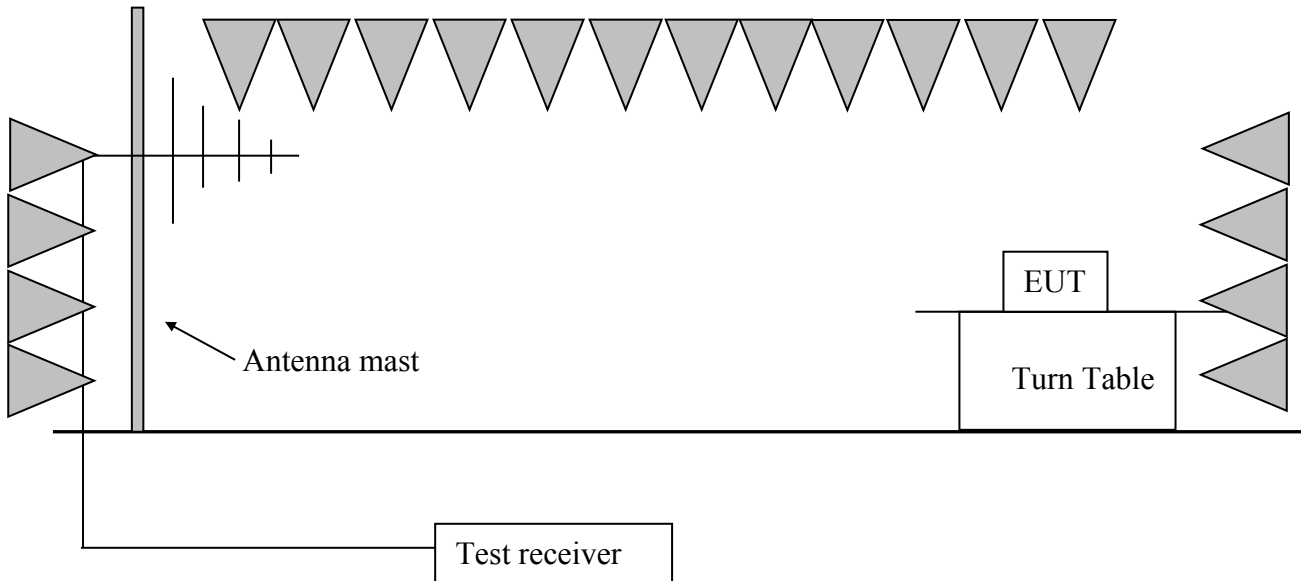

8.3 Test procedure and test setup

The measurement was applied in a semi-anechoic chamber. While testing for spurious emission higher than 1GHz, if applied, the pre-amplifier would be equipped just at the output terminal of the antenna.

Tabletop devices shall be placed on a non-conducting platform with nominal top surface dimensions 1 m by 1.5 m. For emissions testing at or below 1 GHz, the table height shall be 80 cm above the reference ground plane. For emission measurements above 1 GHz, the table height shall be 1.5 m.

The turntable rotated 360 degrees to determine the position of the maximum emission level. The EUT was set 3 meters away from the receiving antenna which was mounted on an antenna mast. The antenna moved up and down between from 1meter to 4 meters to find out the maximum emission level.

The EUT was tested according to DTS test procedure of KDB558074 D01 DTS “Meas Guidance v03r05” for compliance to FCC 47CFR 15.247 requirements.

The radiated emission was measured using the Spectrum Analyzer with the resolutions bandwidth set as:

RBW = 100 kHz, VBW = 300 kHz (30MHz-1GHz)

RBW = 1MHz, VBW = 3MHz (>1GHz for PK);

Remark:

1. Factor= Antenna Factor + Cable Loss (-Amplifier, is employed)
2. Measured level= Original Receiver Reading + Factor
3. Margin = limit – Measured level
4. If the PK measured level is lower than AV limit, the AV test can be elided.

Example:

Assuming Antenna Factor = 30.20dB/m, Cable Loss = 2.00dB,

Gain of Preamplifier = 32.00dB, Original Receiver Reading = 10dBuV.

Then Factor = 30.20 + 2.00 – 32.00 = 0.20dB/m;

Measured level = 10dBuV + 0.20dB/m = 10.20dBuV/m

Assuming limit = 54dBuV/m,

Measured level = 10.20dBuV/m, then Margin = 54 -10.20 = 43.80dBuV/m.

8.4 Test Protocol

Temperature: 25 °C
Relative Humidity: 55 %

The low frequency, which started from 9 kHz to 30MHz, was pre-scanned and the result which was 20dB lower than the limit line per 15.31(o) was not reported.

30MHz~1GHz, 802.11g mode,

Horizontal

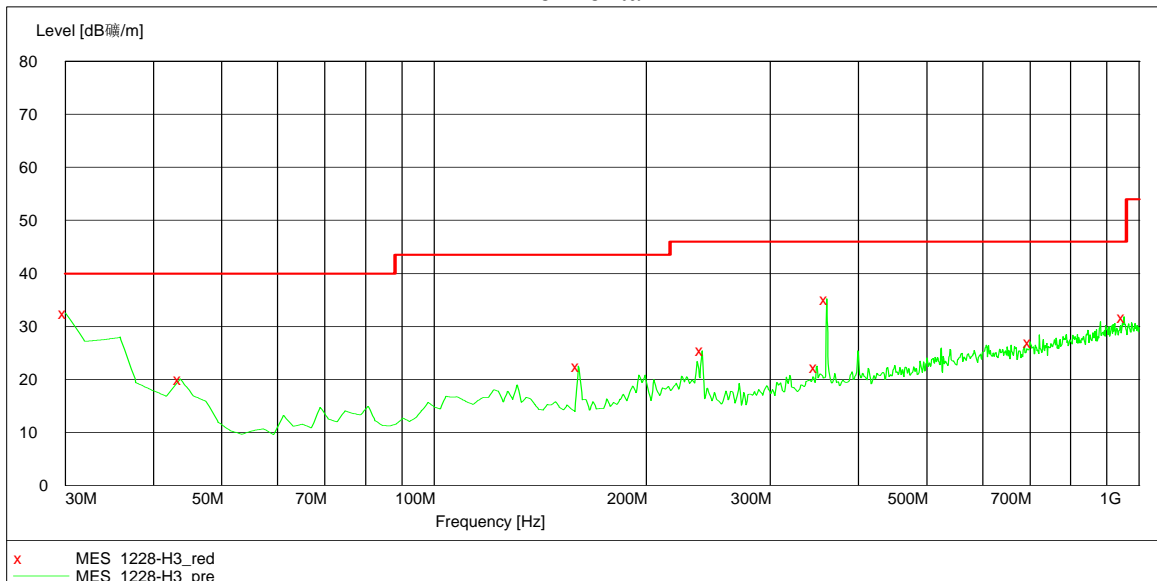

Vertical

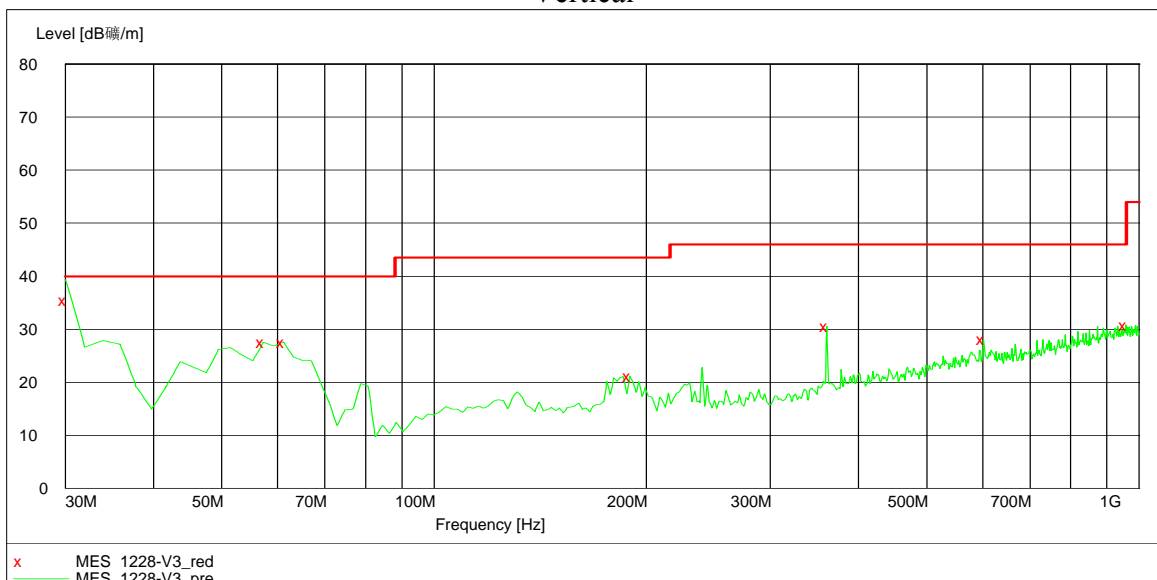

30MHz~1GHz, Test data:

Polarization	Frequency (MHz)	Measured level (dB μ V/m)	Limits (dB μ V/m)	Margin (dB)	Detector
H	30.00	32.5	40.0	7.5	PK
	43.61	20.1	40.0	19.9	PK
	160.24	22.5	43.5	21.0	PK
	239.94	25.4	46.0	20.6	PK
	348.80	22.3	46.0	23.7	PK
	360.46	35.2	46.0	10.8	PK
	700.64	27.1	46.0	18.9	PK
	951.40	31.8	46.0	14.2	PK
V	30.00	35.4	40.0	4.6	QP
	57.21	27.5	40.0	12.5	PK
	61.10	27.6	40.0	12.4	PK
	189.40	21.2	43.5	22.3	PK
	360.46	30.6	46.0	15.4	PK
	601.50	28.0	46.0	18.0	PK
	957.23	30.8	46.0	15.2	PK

Note: The worst test result (30MHz to 1GHz) of channel L (2412MHz) was chosen to list in the report as representative.

Test result above 1GHz:

The emission was conducted from 1GHz to 25GHz.

1: 802.11b

Polarity	Frequency (MHz)	Measured level (dBuV/m)	Limit (dBuV/m)	Factor (dB)	Antenna (cm)	Turn table (deg)	Margin (dB)	Remark
Ver/Hor	2390	50.15	74	-7.80	100	190	23.85	PK
		42.33	54	-7.80	100	190	11.67	AV
	2412	103.45	-	-7.80	100	190	-	PK
		96.65	-	-7.80	100	190	-	AV
	4824	48.58	74	-2.10	100	190	25.42	PK
		40.25	54	-2.10	100	190	13.75	AV
Note:	2412MHz is fundamental signal.							

Polarity	Frequency (MHz)	Measured level (dBuV/m)	Limit (dBuV/m)	Factor (dB)	Antenna (cm)	Turn table (deg)	Margin (dB)	Remark
Ver/Hor	2437	103.75	-	-7.80	100	190	-	PK
		94.67	-	-7.80	100	190	-	AV
	4874	49.45	74	-2.10	100	190	24.55	PK
		41.26	54	-2.10	100	190	12.74	AV
	7311	48.33	74	6.50	100	190	25.67	PK
		39.62	54	6.50	100	190	14.38	AV
Note:	2437MHz is fundamental signal.							

Polarity	Frequency (MHz)	Measured level (dBuV/m)	Limit (dBuV/m)	Factor (dB)	Antenna (cm)	Turn table (deg)	Margin (dB)	Remark
Ver/Hor	2462	103.66	-	-7.80	100	190	-	PK
		93.68	-	-7.80	100	190	-	AV
	2483.5	50.56	74	-7.50	100	190	23.44	PK
		42.13	54	-7.50	100	190	11.87	AV
	4924	49.94	74	-2.10	100	190	24.06	PK
		38.92	54	-2.10	100	190	15.08	AV
	7386	48.26	74	6.50	100	190	25.74	PK
		39.46	54	6.50	100	190	14.54	AV
Note:	2462MHz is fundamental signal.							

2: 2.4G band 802.11g

Polarity	Frequency (MHz)	Measured level (dBuV/m)	Limit (dBuV/m)	Factor (dB)	Antenna (cm)	Turn table (deg)	Margin (dB)	Remark
Ver/Hor	2390	50.46	74	-7.80	100	190	23.54	PK
		41.31	54	-7.80	100	190	12.69	AV
	2412	108.84	-	-7.80	100	190	-	PK
		95.76	-	-7.80	100	190	-	AV
	4824	49.43	74	-2.10	100	190	24.57	PK
		36.33	54	-2.10	100	190	17.67	AV
Note:	2412MHz is fundamental signal.							

Polarity	Frequency (MHz)	Measured level (dBuV/m)	Limit (dBuV/m)	Factor (dB)	Antenna (cm)	Turn table (deg)	Margin (dB)	Remark
Ver/Hor	2437	108.36	-	-7.80	100	190	-	PK
		95.34	-	-7.80	100	190	-	AV
	4874	51.24	74	-2.10	100	190	22.76	PK
		41.35	54	-2.10	100	190	12.65	AV
	7311	46.46	74	6.50	100	190	27.54	PK
		39.56	54	6.50	100	190	14.44	AV
Note:	2437MHz is fundamental signal.							

Polarity	Frequency (MHz)	Measured level (dBuV/m)	Limit (dBuV/m)	Factor (dB)	Antenna (cm)	Turn table (deg)	Margin (dB)	Remark
Ver/Hor	2462	108.35	-	-7.80	100	190	-	PK
		96.14	-	-7.80	100	190	-	AV
	2483.5	50.38	74	-7.50	100	190	23.62	PK
		42.12	54	-7.50	100	190	11.88	AV
	4924	51.47	74	-2.10	100	190	22.53	PK
		40.47	54	-2.10	100	190	13.53	AV
	7386	45.56	74	6.50	100	190	28.44	PK
		36.67	54	6.50	100	190	17.33	AV
Note:	2462MHz is fundamental signal.							

3: 802.11n20

Polarity	Frequency (MHz)	Measured level (dBuV/m)	Limit (dBuV/m)	Factor (dB)	Antenna (cm)	Turn table (deg)	Margin (dB)	Remark
Ver/Hor	2390	51.44	74	-7.80	100	190	22.56	PK
		42.16	54	-7.80	100	190	11.84	AV
	2412	107.45	-	-7.80	100	190	-	PK
		92.84	-	-7.80	100	190	-	AV
	4824	49.65	74	-2.10	100	190	24.35	PK
		38.68	54	-2.10	100	190	15.32	AV
Note:	2412MHz is fundamental signal.							

Polarity	Frequency (MHz)	Measured level (dBuV/m)	Limit (dBuV/m)	Factor (dB)	Antenna (cm)	Turn table (deg)	Margin (dB)	Remark
Ver/Hor	2437	107.84	-	-7.80	100	190	-	PK
		93.41	-	-7.80	100	190	-	AV
	4874	47.83	74	-2.10	100	190	26.12	PK
		38.57	54	-2.10	100	190	15.43	AV
	7311	45.78	74	6.50	100	190	28.22	PK
		38.47	54	6.50	100	190	15.53	AV
Note:	2437MHz is fundamental signal.							

Polarity	Frequency (MHz)	Measured level (dBuV/m)	Limit (dBuV/m)	Factor (dB)	Antenna (cm)	Turn table (deg)	Margin (dB)	Remark
Ver/Hor	2462	107.64	-	-7.80	100	190	-	PK
		92.53	-	-7.80	100	190	-	AV
	2483.5	50.24	74	-7.50	100	190	23.76	PK
		40.64	54	-7.50	100	190	13.36	AV
	4924	48.42	74	-2.10	100	190	25.58	PK
		37.68	54	-2.10	100	190	16.32	AV
	7386	45.26	74	6.50	100	190	28.74	PK
		38.66	54	6.50	100	190	15.34	AV
Note:	2462MHz is fundamental signal.							

4: 2.4G band 802.11n HT40

Polarity	Frequency (MHz)	Measured level (dBuv/m)	Limit (dBuv/m)	Factor (dB)	Antenna (cm)	Turn table (deg)	Margin (dB)	Remark
Ver/Hor	2390	50.33	74	-7.80	100	190	23.67	PK
		41.61	54	-7.80	100	190	12.39	AV
	2422	106.36	-	-7.80	100	190	-	PK
		91.25	-	-7.80	100	190	-	AV
	4844	48.22	74	-2.10	100	190	25.78	PK
		39.18	54	-2.10	100	190	14.82	AV
Note:	2422MHz is fundamental signal.							

Polarity	Frequency (MHz)	Measured level (dBuv/m)	Limit (dBuv/m)	Factor (dB)	Antenna (cm)	Turn table (deg)	Margin (dB)	Remark
Ver/Hor	2437	106.45	-	-7.80	100	190	-	PK
		92.22	-	-7.80	100	190	-	AV
	4874	48.43	74	-2.10	100	190	25.57	PK
		38.68	54	-2.10	100	190	15.32	AV
	7311	45.36	74	6.50	100	190	28.64	PK
		38.67	54	6.50	100	190	15.33	AV
Note:	2437MHz is fundamental signal.							

Polarity	Frequency (MHz)	Measured level (dBuv/m)	Limit (dBuv/m)	Factor (dB)	Antenna (cm)	Turn table (deg)	Margin (dB)	Remark
Ver/Hor	2452	106.67	-	-7.80	100	190	-	PK
		91.32	-	-7.80	100	190	-	AV
	2483.5	48.18	74	-7.50	100	190	25.82	PK
		39.68	54	-7.50	100	190	14.32	AV
	4904	47.77	74	-2.10	100	190	26.23	PK
		38.48	54	-2.10	100	190	15.52	AV
	7356	46.34	74	6.50	100	190	27.66	PK
		38.83	54	6.50	100	190	15.17	AV
Note:	2452MHz is fundamental signal.							

9. Power line conducted emission

Test result: Pass

9.1 Limit

Frequency of Emission (MHz)	Conducted Limit (dBuV)	
	QP	AV
0.15-0.5	66 to 56*	56 to 46 *
0.5-5	56	46
5-30	60	50

* Decreases with the logarithm of the frequency.

9.2 Test configuration

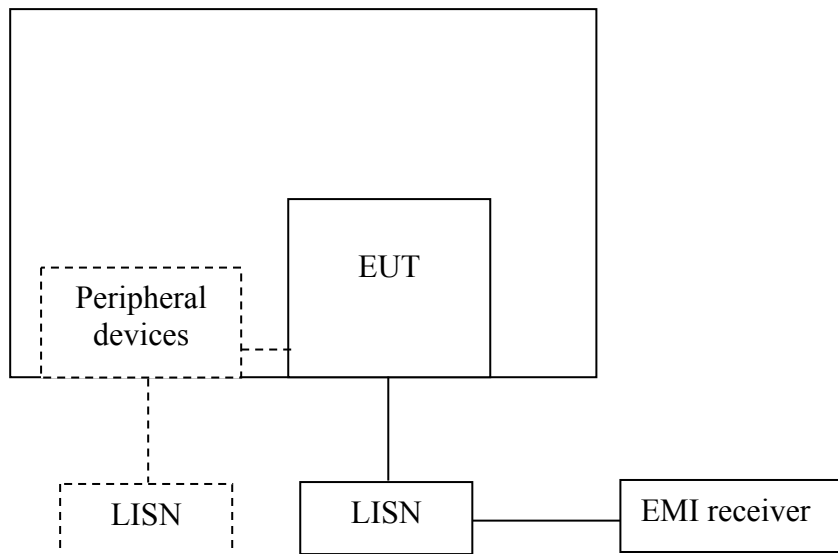

For table top equipment, wooden support is 0.8m height table

For floor standing equipment, wooden support is 0.1m height rack.

9.3 Test procedure and test set up

The EUT are connected to the main power through a line impedance stabilization network (LISN). This provides a $50\Omega/50\mu\text{H}$ coupling impedance for the measuring equipment. The peripheral devices are also connected to the main power through a LISN that provides a $50\Omega/50\mu\text{H}$ coupling impedance with 50Ω termination.

Both sides (Line and Neutral) of AC line are checked for maximum conducted interference. In order to find the maximum emission, the relative positions of equipment and all of the interface cables must be changed according to ANSI C63.4 on conducted measurement. The bandwidth of the test receiver is set at 9 kHz.

9.4 Test protocol

Temperature : 22°C
Relative Humidity : 52%

L line

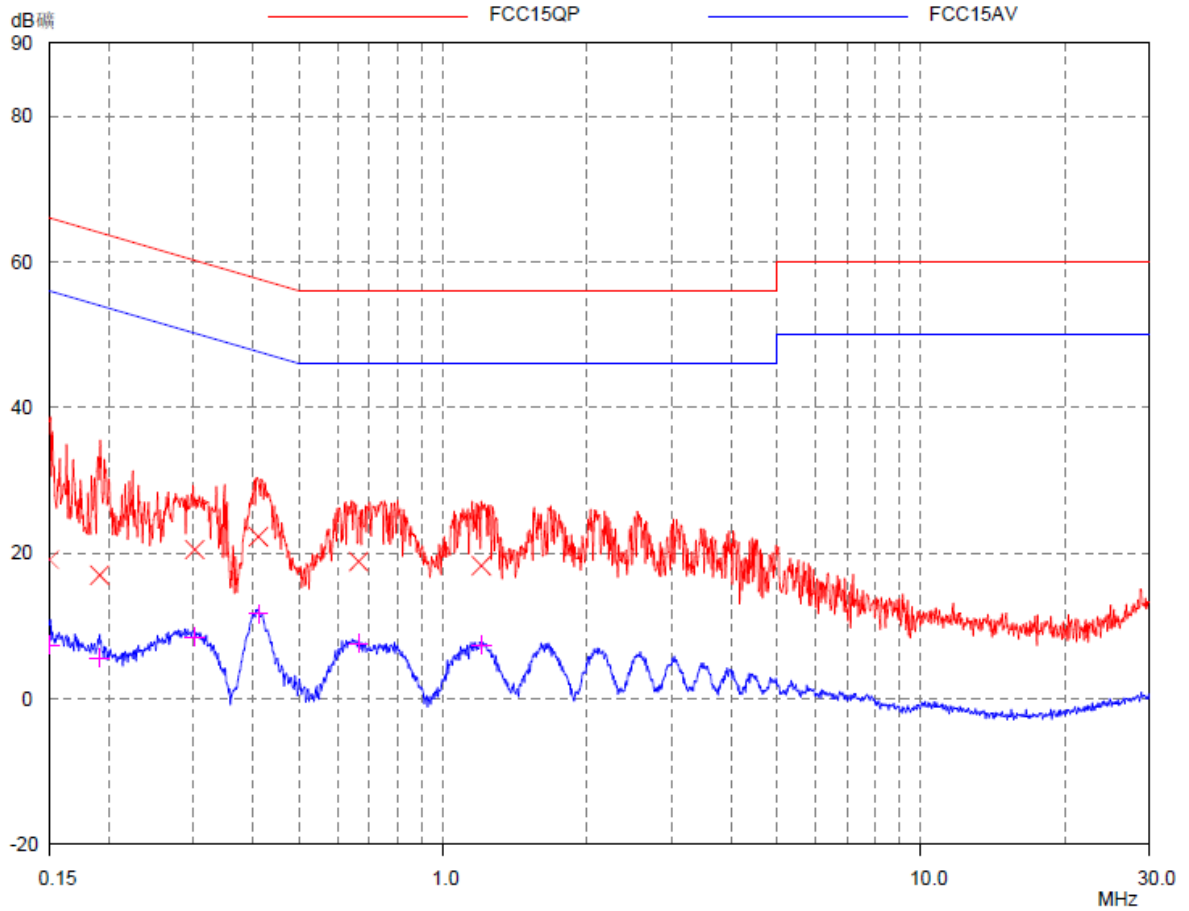

Test Data:

Frequency (MHz)	Quasi-peak			Average		
	level dB(μV)	Limit dB(μV)	Margin (dB)	level dB(μV)	limit dB(μV)	Margin (dB)
0.150	19.12	66.00	46.88	7.42	56.00	48.58
0.191	16.98	64.01	47.03	5.64	54.01	48.37
0.302	20.49	60.20	39.71	8.50	50.20	41.70
0.410	22.24	57.64	35.40	11.68	47.64	35.96
0.665	18.85	56.00	37.15	7.64	46.00	38.36
1.200	18.28	56.00	37.72	7.39	46.00	38.61

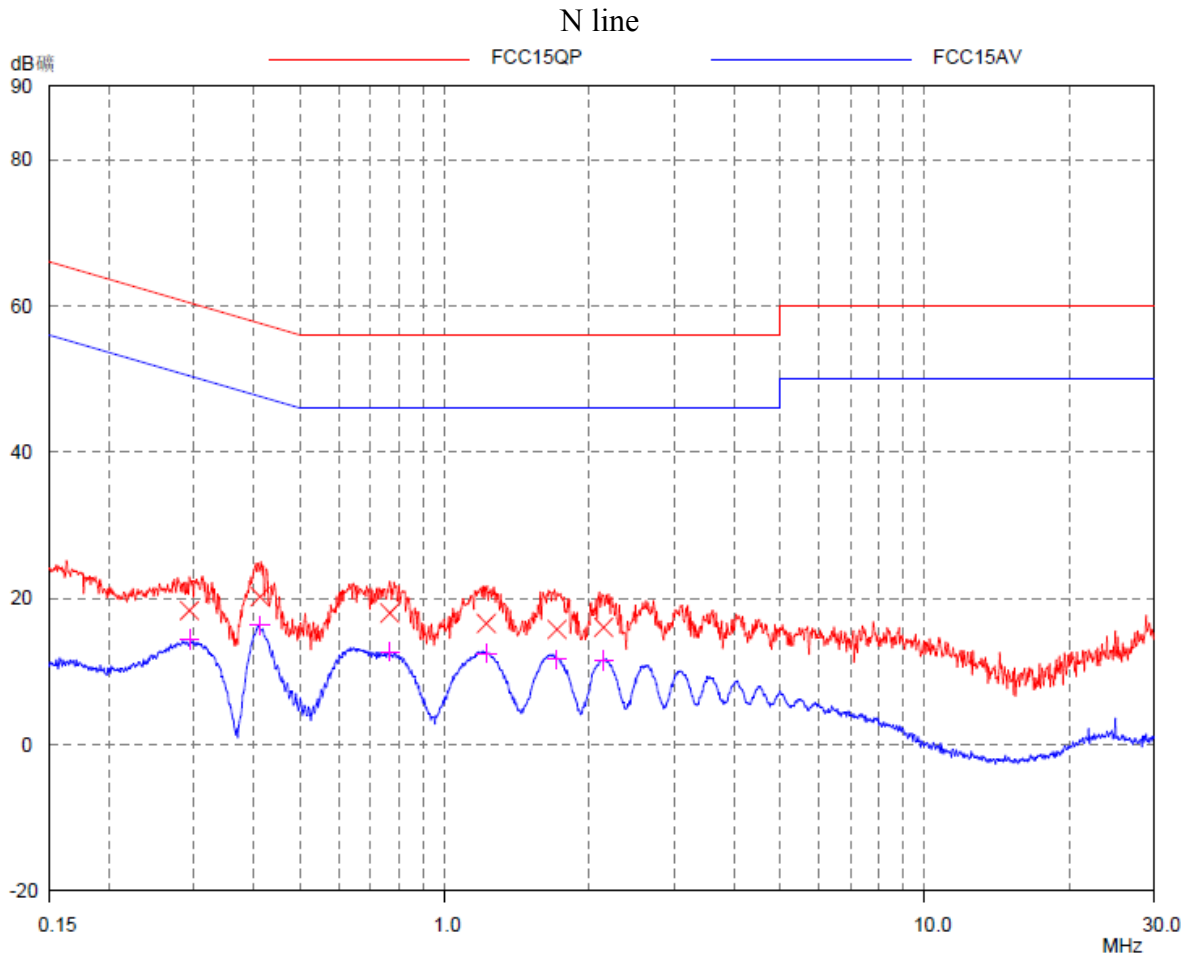

Test Data:

Frequency (MHz)	Quasi-peak			Average		
	level dB(μV)	Limit dB(μV)	Margin (dB)	level dB(μV)	limit dB(μV)	Margin (dB)
0.293	18.35	60.43	42.08	14.36	50.43	36.07
0.412	20.23	57.61	37.38	16.31	47.61	31.30
0.768	17.98	56.00	38.02	12.69	46.00	33.31
1.220	16.59	56.00	39.41	12.48	46.00	33.52
1.713	15.74	56.00	40.26	11.63	46.00	34.37
2.142	16.05	56.00	39.95	11.56	46.00	34.44

Note: The worst test results of channel L (2412MHz, 802.11g) was chosen to list in the report as representative.