

**• Bluetooth® Radio**

- Fully embedded Bluetooth® V4.2 single mode
- ARM® Cortex-M0 @ 32-bit

• Support Profiles

- BLE (Master and slave)
- The generic attribute profile (GATT)

• User Interface

- Send AT command over UART
- Firmware upgrade over the air (OTA)
- Transmit data: 1Mbps transmission speed
- I²C ,SPI interface (Master)
- Watchdog and RTC
- 2 PWM modules

• General I/O

- 14 general purpose I/Os
- 2 analog I/Os (10bit ADC)

• Power dissipation

- Standby power consumption of less than 1uA in hibernation mode (wakeable)

• FCC/RED/IC/RoHs and Bluetooth® qualified**• Single voltage supply: 1.8– 3.6V typical****• Small form factor: 7.0 x 7.0x 1.0mm****• Operating temperature range: -40 °C to 105 °C**

Sept 17, 2018

VERSION HISTORY

Version	Comment
V1.1	Change the Pin GPIO to DIO in the schematic diagram

Confidential and Proprietary – Ehong Technology Co.,Ltd

NO PUBLIC DISCLOSURE PERMITTED: Please report postings of this document on public servers or websites to: DCC@ehlink.com.cn

Restricted Distribution: Not to be distributed to anyone who is not an employee of either Ehong Technology Co.,Ltd or its affiliated companies without the express approval of Ehong Configuration Management.

Not to be used, copied, reproduced, or modified in whole or in part, nor its contents revealed in any manner to others without the express written permission of Ehong Technology Co.,Ltd.

This Bluetooth trademark is owned by the Bluetooth SIG Inc., USA and is licensed to Ehong Technologies. All other trademarks listed herein are owned by their respective owners.

© 2016 Ehong Technology Co.,Ltd. All rights reserved.

1. Contents

1. Description	4
2. Applications	4
3. EH-ES101 Product numbering	4
4. Pinout and Terminal Description	5
4.1. Pin Configuration	5
5. Physical Interfaces	7
5.1. GPIO	7
5.2. ADC	7
5.3. PWM	8
5.4. UART	8
5.5. I2C Master	8
5.6. SPI Master	8
6. Electrical Characteristics	8
6.1. Recommended Operation Conditions	8
6.2. Absolute Maximum Rating	9
6.3. Input/Output Terminal Characteristics	9
6.4. Power Consumption	9
7. Reference Design	10
8. Layout and Soldering Considerations	11
8.1. EH-ES101 external view	11
8.2. PCB package outline drawing	11
9. Tape and reel information	12
9.1. Tapa orientation	12
9.2. Tape dimensions	12
9.3. Reel information	13
10. The tray information	13
11. Soldering Recommendations	14
12. Contact Information	14

1. Description

EH-ES101 series is a powerful, highly flexible, ultra-low power Bluetooth smart SIP module base on BlueNRG-1 SoC from ST. Embedded 2.4GHz transceiver; the EH-ES101 module provides a complete RF solution allowing faster time-to-market with reduced development costs.

The module offers all Bluetooth® low energy features: radio, stack, profiles and application space for customer application, so no external control processor is needed. The module also provides flexible hardware interfaces to connect sensors, simple user interfaces or even displays directly to the module.

The module is small in size and support the module of selecting the external antenna to facilitate the flexible development of the product. The module can be powered directly with a standard 3V coin cell batteries or pair of AAA batteries. In lowest power sleep mode it consumes only less 1uA and will wake up in few hundred microseconds.

After buying Bluetooth® module, we provide free technical support APP of iOS system or APP Android system.

2. Applications

- Sports and fitness
- Healthcare
- Home entertainment
- Office and mobile accessories
- Automotive
- Commercial
- Watches
- Human interface devices

3. EH-ES101 Product numbering

EH-ES101

- A. EH ----- Company Name(Ehong)
B. ES101 ----- Module Name

4. Pinout and Terminal Description

4.1. Pin Configuration

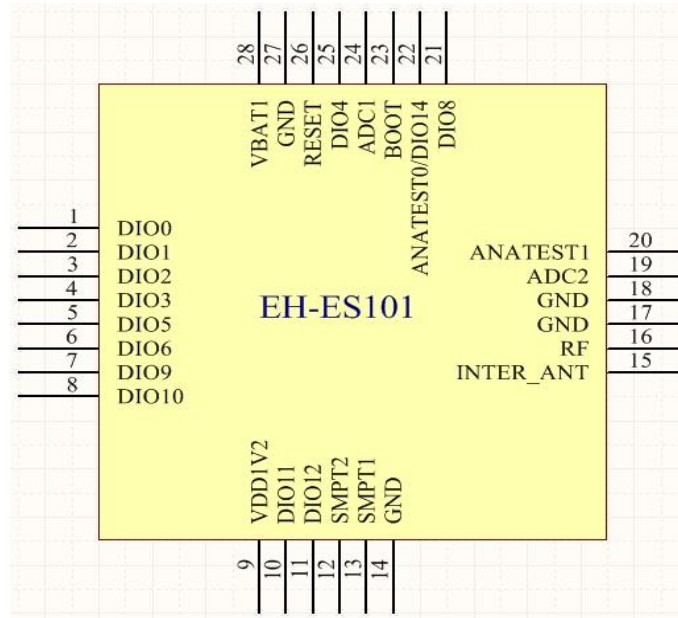

Figure 1: Pinout of EH-ES101

Symbol	Pin	PAD Type	Description
DIO0	1	General purpose digit I/O	See IO function map
DIO1	2	General purpose digit I/O	See IO function map
DIO2	3	General purpose digit I/O	See IO function map
DIO3	4	General purpose digit I/O	See IO function map
DIO5	5	General purpose digit I/O	See IO function map
DIO6	6	General purpose digit I/O	See IO function map
DIO9	7	General purpose digit I/O	See IO function map, also work as SWDCLK
DIO10	8	General purpose digit I/O	See IO function map, also work as SWDIO
VDD1V2	9	1.2V digit core output	Connect a capacitor
DIO11	10	General purpose digit I/O	See IO function map
DIO12	11	General purpose digit I/O	See IO function map
SMPT2	12	SMPS output to external filter / VCC input	Connect to VCC or an inductor
SMPT1	13	SMPS output to external filter	
GND	14	Powered ground	

RF	16	Use an internal antenna or connect to an external antenna.	
GND	17	Powered ground	
GND	18	Powered ground	
ADC2	19	ADC input 2	
ANATEST1	20	Antenna test pin1	Used for indicate RF's TX/RX event, also can user for extern antenna switch
DIO8	21	General purpose digit I/O	See IO function map
DIO14/TEST0	22	General purpose digit I/O / Analog output	See IO function map
DIO7/BOOT	23	General purpose digit BOOT pin	See IO function map, used for BOOT pin(vcc) for jump to bootloader when power on
ADC1	24	ADC input 1	
DIO4	25	General purpose digit I/O	See IO function map
RESET	26	System reset pin	Active low level
GND	27	Powered ground	
VBAT1	28	Powered VCC	1.8-3.6V

Table 1: PIN Terminal Description

Pin name ^a	GPIO mode"000"		Mode serial1"001"		Mode serial0"100"		Mode serial2"101"	
	Type	Signal	Type	Signal	Type	Signal	Type	Signal
IO0	I/O	GPIO 0	I	UART_CTS	I/O	SPI_CLK	-	-
IO1	I/O	GPIO 1	O	UART_RTS	I/O	SPI_CS1	I	PDM_DAT A
IO2	I/O	GPIO 2	O	PWM0	O	SPI_OUT	O	PDM_CLK
IO3	I/O	GPIO 3	O	PWM1	I	SPI_IN	O	-
IO4	I/O	GPIO 4	I	UART_RXD	I/O	I2C2_CLK	O	PWM0
IO5	I/O	GPIO 5	O	UART_TXD	I/O	I2C2_DAT	O	PWM1
IO6	I/O	GPIO 6	O	UART_RTS	I/O	I2C2_CLK	I	PDM_DAT A
IO7	-	-	I	UART_CTS	I/O	I2C2_DAT	O	PDM_CLK
IO8	I/O	GPIO 8	O	UART_TXD	I/O	SPI_CLK	I	PDM_DAT A
IO9	I/O	GPIO 9	I	SWCLK	I	SPI_IN	-	-
IO10	I/O	GPIO 10	I	SWDIO	O	SPI_OUT	-	-
IO11	I/O	GPIO 11	I	UART_RXD	I/O	SPI_CS1	-	-
IO12	OD	GPIO 12 ^b	I	-	I/O	I2C2_DAT	-	-
IO14	I/O	GPIO 14	I/O	I2C1_CLK	I/O	SPI_CLK	O	-

Table 2: IO function MAP

5. Physical Interfaces

5.1. GPIO

- 14 IOs are provided. Every IO can program for other function.
- All the GP IOs are in high impedance under reset. All the IOs are in high impedance in low power modes (sleep and standby). If pre-programmed as wake up sources, pins IO9, IO10 and IO11 are in input pull up.
- All the GIOs can be programmed for an interrupt source. Edge detection or level detection, and falling/rising or both.
- GIO0~GIO8 and GIO14 can program input pull down.
- GIO9~GIO11 can program input pull up.
- GIO12 can only be General Purpose Input pins (not output).

When power for 3.3V, internal Pull resistor is:

Name	Description Name	Min	Type	Max	Unit
RPD	Pull-down Value	53	84	144	KΩ
RPU	Pull-up Value	57	81	122	

Table 3: Internal Pull for 3.3V

When power for 1.8V, internal Pull resistor is:

Name	Description Name	Min	Type	Max	Unit
Digital input and output when 1.8V supply					
RPD	Pull-down Value	117	202	363	KΩ
RPU	Pull-up Value	135	211	334	

Table 4: Internal Pull for 1.8V

Note:

A. GIO7 can work as BOOT pin. when power on, if GIO7 is high level, CPU will jump to bootloader mode, and this time can update the firmware by UART.

B. GIO9 and GIO10 can work as SWDCLK and SWDIO. If need debug or download also can use Jlink OB or ST-LINK.

The IOs programmed to be wake up sources need an external drive according to the selected level sensitivity. If the wake up level is high level, a pull down drive should be used. If the wake up level is low level, a pull up drive should be used. If no external drive is applied, IO9, IO10 and IO11 are only sensitive to low level as they have an internal pull up (activated by default). IO12 do not have an internal pull and therefore require an external drive.

5.2. ADC

2 ADCs are provided.

Main features are:

Sampling frequency 1 MHz.

One channel in single ended or differential input through the pins ADC1 and ADC2.

Internal temperature and battery level conversion.

5.3. PWM

2 PWMs can be driven by internal PWM module.

5.4. UART

This is a standard UART interface for communicating with other serial devices. The UART interface provides a simple mechanism for communicating with other serial devices using the TTL protocol.

When using low-power mode, TXD needs to pull up resistance, and the reference value is 4.7k.

Main features are:

- Programmable baud rate can reach up to 921600bps.

- Programmable data frame of 5, 6, 7 or 8 bits of data.

- Even, odd, stick or no-parity bit generation and detection.

- Programmable 1 or 2 stop bit.

5.5. I2C Master

The module can act as an I2C master when configured by software.

Main features are:

- Up to 400 Kb/s in fast mode and up to 100 Kb/s in standard mode.

Operating modes supported are master mode, slave mode, master/slave mode for multi-master system with bus arbitration.

5.6. SPI Master

The module can act as an SPI master (mode 0) when configured by software.

Main features are:

- Maximal supported baud rate is 1 MHz in slave mode and 8 MHz in master mode.

6. Electrical Characteristics

6.1. Recommended Operation Conditions

Operating Condition	Min	Typical	Max	Unit
Operating Temperature Range	-30	--	+80	°C
Battery (VDD_BAT) operation	1.8	3.3	+3.6	V
Frequency Range	2402	-2	2480	MHz
ADC Input range	0	-	+1.2	V

Table 5: Recommended Operation Conditions

Rating	Min	Max	Unit
Storage Temperature	-40	+85	°C
Battery (VBAT) operation*	1.8	3.6	V
I/O supply voltage	-0.4	+3.6	V
Other Terminal Voltages except RF	V _{ss} -0.4	VBAT+0.4	V

Table 6: Absolute Maximum Rating

In the absence of damage, the maximum 10% of product life is allowed for short term operation, but the output regulation and other specifications will not be guaranteed in excess of 4.2V.

6.2. Absolute Maximum Rating

*Short-term operation up to a maximum of 10% of product lifetime is permissible without damage, but output regulation and other specifications are not guaranteed in excess of 4.2V.

6.3. Input/Output Terminal Characteristics

Input Voltage Levels	Min	Typical	Max	Unit
V _{IL} input logic level low	-0.4	-	0.4	V
V _{IH} input logic level high	0.7 x VDD	-	VDD + 0.4	V
T _r /T _f	-	-	25	ns
Output Voltage Levels	Min	Typical	Max	Unit
V _{OL} output logic level low, I _{OL} = 4.0mA	-	-	0.4	V
V _{OH} output logic level high, I _{OH} = -4.0mA	0.75 x VDD	-	--	V
T _r /T _f	-	-	5	ns

Table 7: Digital I/O Characteristics

Condition	Class	Max Rating
Human Body Model Contact Discharge per JEDEC EIA/JESD22-A114	2	2000V (all pins)
Machine Model Contact Discharge per JEDEC EIA/JESD22-A115	200V	200V (all pins)
Charged Device Model Contact Discharge per JEDEC EIA/JESD22-C101	III	500V (all pins)

Table 8: ESD Protection

6.4. Power Consumption

Current consumption is measured using a battery.

(1)When the DC-DC converter is activated, the power consumption is as follows:

Pattern	describe	Total typical current at 3.3V (average)
Standby	All functions are shut down. GPIO preprogramming is required to wake up.	<700nA
Sleep	32kHz on and 24KB RAM retain	<2.1uA
Model at full speed	Open all functions	2.5mA-3.6mA
RF TX active	VDD=3.3V	~8.3mA peak
RF RX active	VDD=3.3V	~7.7mA peak

Table 9: Current Consumption

(2)The power consumption is as follows when the DC-DC converter is not used:

pattern	Discribe	Total typical current at 3.3V (average)
Standby	All functions are shut down. GPIO preprogramming is required to wake up.	<700nA
Sleep	32kHz on and 24KB RAM retain	<2.1uA
Model at full speed	Open all functions	2.5mA-3.6mA
RF TX active	VDD=3.3V	~15.3mA peak
RF RX active	VDD=3.3V	~14.5mA peak

7. Reference Design

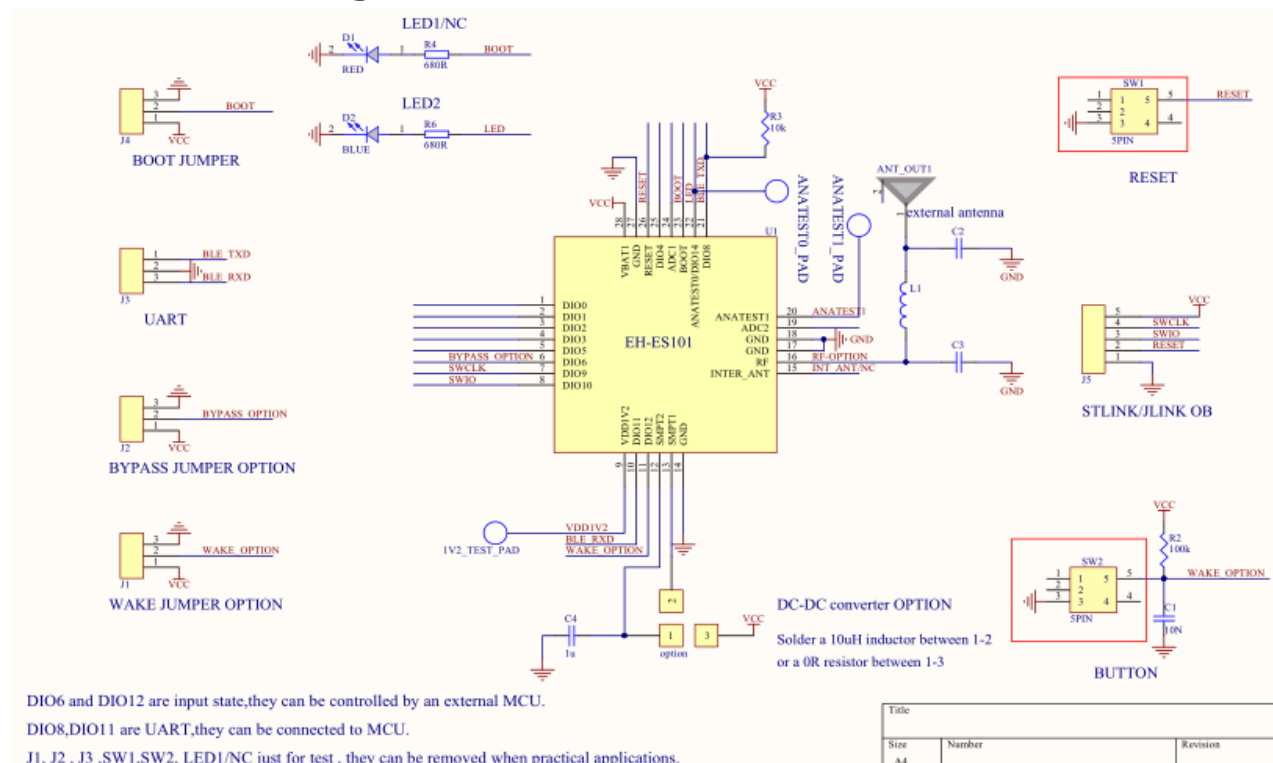

Figure 2: Reference Design important

Note:

- A. DC-DC transverter select;
 - (1) When the DC-DC converter is not used, a 0 - o resistor is welded to the welding plate 1-3, otherwise it cannot work;
 - (2) When the dc-dc converter is activated, a 10uH inductance is welded to the welding disc 1-2.This method can reduce peak power consumption, and the peak current can be reduced by about 45%.
- B. Pin23 BOOT pin can't connect to VCC, or else will always goto boot mode;
- C. Pin9 VDD1V2 need connect a test pad.

8. Layout and Soldering Considerations

8.1. EH-ES101 external view

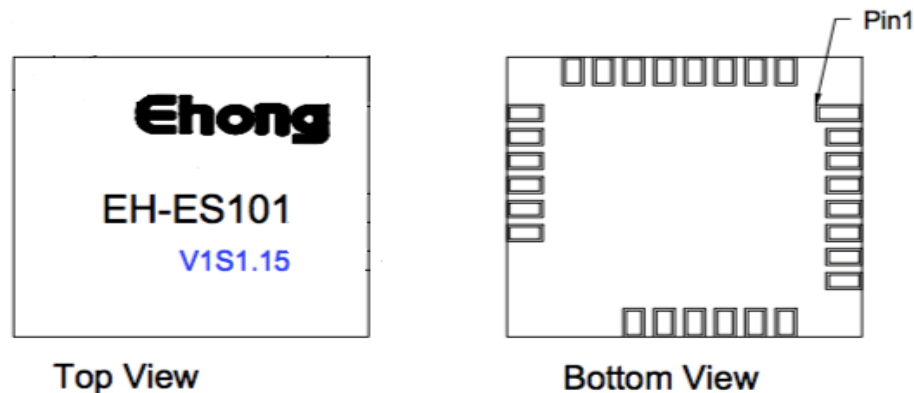

Figure 3: EH-ES101 External view

8.2. PCB package outline drawing

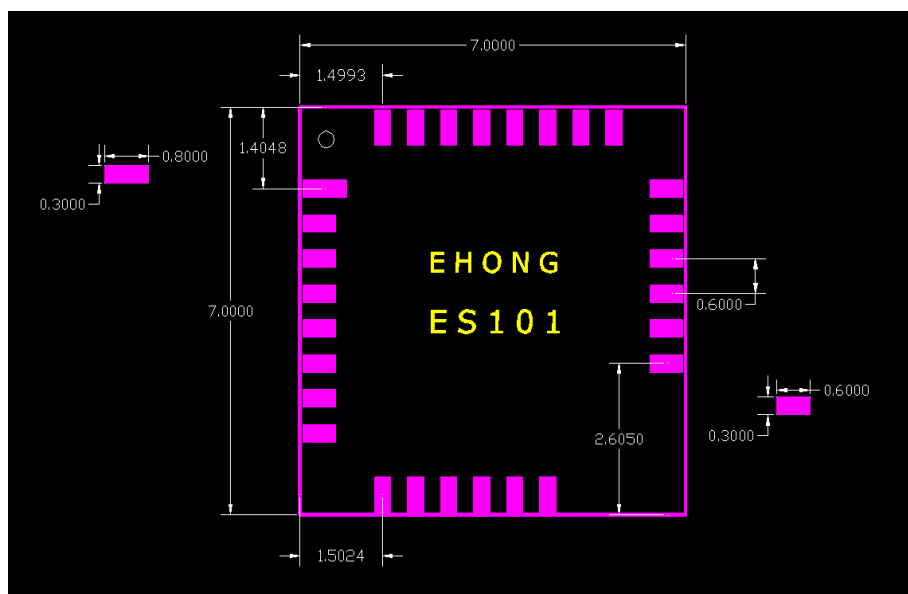

Figure 4:EH-ES101 package information (TOP

9. Tape and reel information

EH-ES101 modules are supplied on the tape and reels.

For tape and reel packing and labeling, see IC packing and labeling specification.

9.1. Tapa orientation

Figure 5 shows the EH-ES101 module LGA packing tape orientation.

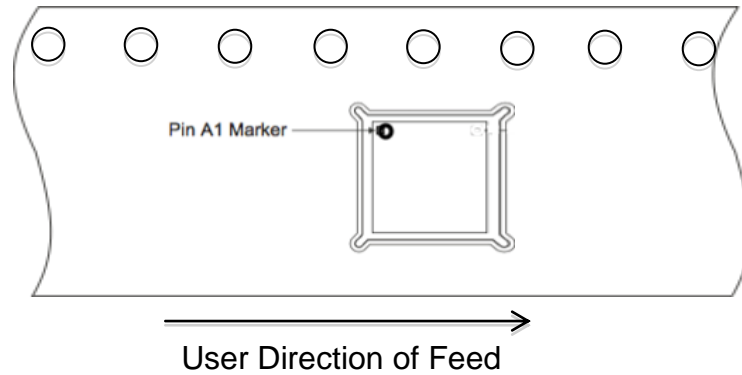

Figure 5: EH-ES101 module tape orientation

9.2. Tape dimensions

Figure 6 shows and Table10 lists the dimensions of the tape for the EH-ES101 module.

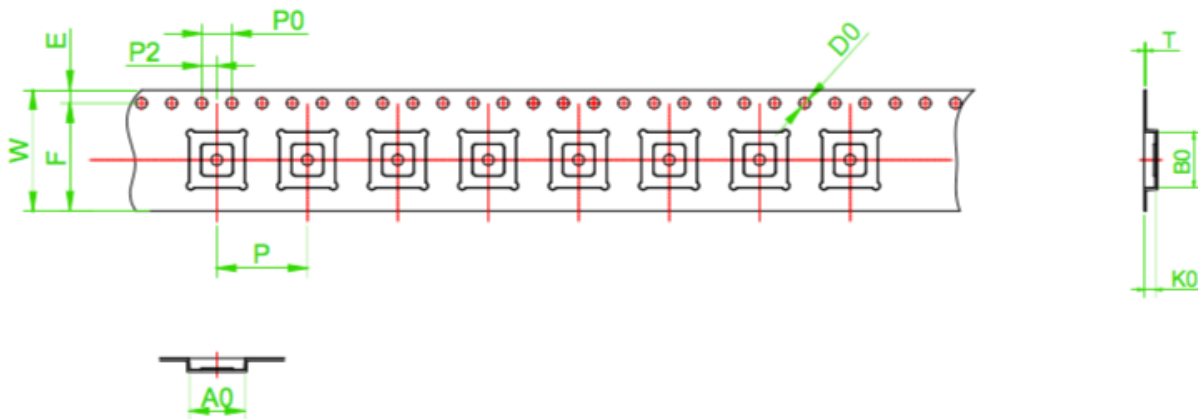

Figure 6 : EH-ES101 tape dimensions

ITEM	W	A0	B0	K0	P	F	E	D0	P0	P2	T
DIM(mm)	16.0	7.3	7.3	1.5	12	7.5	1.75	1.5	4	2.0	0.3

Table 10: EH-ES101 module tape dimensions

9.3. Reel information

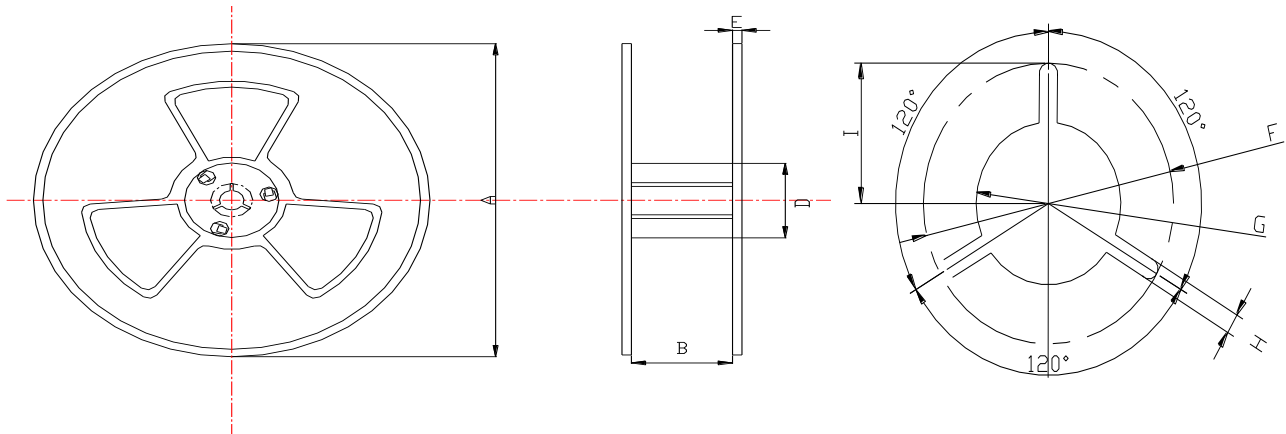

Figure 7 : EH-ES101 reel dimensions

Item	A	B	D	E	F	G	H	I
Unit:mm	330	16.4	100	2.0	21.5	13.2	2.6	10.75

Table 11: EH-ES101 module reel dimensions

10. The tray information

Figure 8 is the size of EH-ES101 pallet, and the number of chips in the tray is 26*10=260PCS.

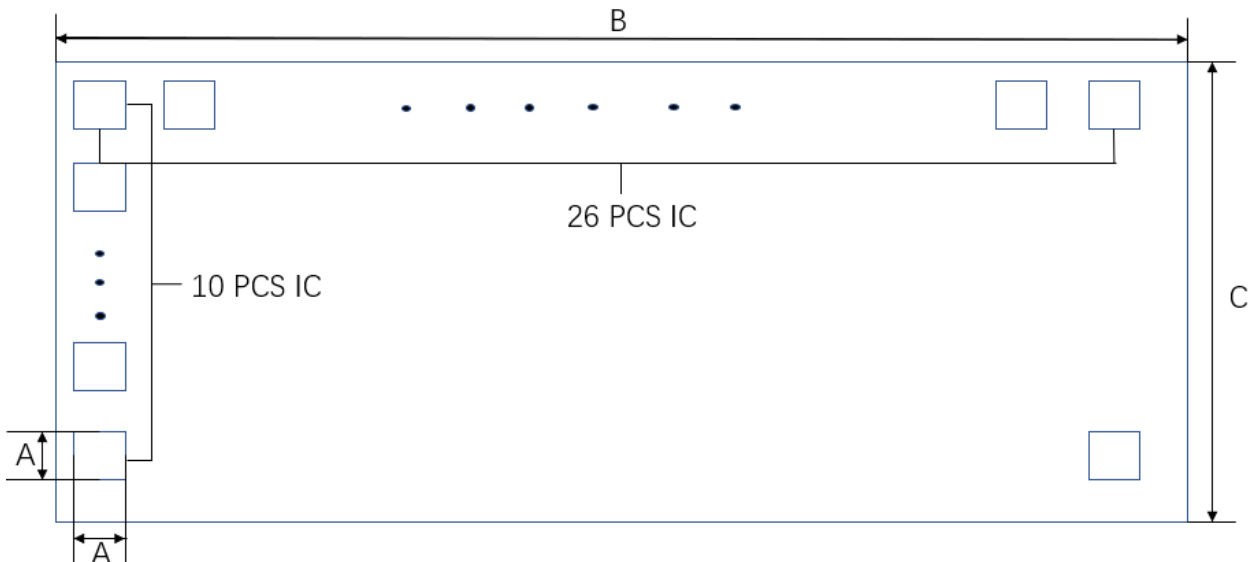

Figure 8: EH-ES101 pallet size.

11. Soldering Recommendations

EH-ES101 is compatible with industrial standard reflow profile for Pb-free solders. The reflow profile used is dependent on the thermal mass of the entire populated PCB, heat transfer efficiency of the oven and particular type of solder paste used. Consult the datasheet of particular solder paste for profile configurations.

SMT stencil making requirements

- ✧ If Bluetooth module PIN pitch $\geq 0.25\text{mm}$ and other component PIN pitch $\geq 0.25\text{mm}$, so you choose SMT stencil thickness **0.15mm**.
- ✧ If Bluetooth module PIN pitch $\geq 0.25\text{mm}$ and other component PIN pitch $\leq 0.25\text{mm}$, so you choose SMT Ladder stencil Bluetooth module thickness **0.15mm** other component thickness **0.13mm**.
- ✧ Solder pad open via ratio **Length 1:1.2, width 1:1**.

12. Contact Information

Sales: sales@ehlink.com.cn

Technical support: support@ehlink.com.cn

Website: <http://www.ehonglink.com>

Tel: 021-61263536

Fax: 021-61263536

Address: Suite501, No.3 building, No.439 Jinglian road, Minhang district, Shanghai, China

FCC Statement

Any Changes or modifications not expressly approved by the party responsible for compliance could void the user's authority to operate the equipment.

This device complies with part 15 of the FCC Rules. Operation is subject to the following two conditions: (1) This device may not cause harmful interference, and

(2) This device must accept any interference received, including interference that may cause undesired operation.

FCC Radiation Exposure Statement:

This equipment complies with FCC radiation exposure limits set forth for an uncontrolled environment. This equipment should be installed and operated with minimum distance 20cm between the radiator & your body.

FCC Label Instructions:

The outside of final products that contains this module device must display a label referring to the enclosed module. This exterior label can use wording such as: "Contains Transmitter Module

FCC ID: 2ACCRES101", or "Contains FCC ID: 2ACCRES101". Any similar wording that expresses the same meaning may be used