

TEST REPORT

Report No.: SHE23120009-02DE

Date: 2024-02-01

Page 1 of 59

Applicant : Ehong Technology Co.,Ltd
Address of Applicant : Room 501, No.485 Xingmei Road,
Minhang Dis,Shanghai, China.

Product Name : BLE Module
Brand Name : Ehong
Model Name : EQM100-1B, EQM100-1P, EQM100-1U
Sample Acquisition Method : Sent by Client
Sample No. : E23120009-01#02(Conducted Sample)
E23120009-01#03(EQM100-1B Radiation Sample)
E23120009-01#06(EQM100-1U Radiation Sample)
E23120009-01#07(EQM100-1P Radiation Sample)

FCC ID : 2ACCREQM1001
ISED Number : 20625-EQM1001

Standards : FCC CFR47 Part 15, Subpart C
RSS-Gen (Issue 5, Amd.2-Feb 2021)
RSS-247 (Issue 3, August 2023)

Date of Receipt : 2023-12-07
Date of Test : 2023-12-08~ 2024-02-01
Date of Issue : 2024-02-01

Remark:

This report details the results of the testing carried out on one sample, the results contained in this report do not relate to other samples of the same product. The manufacturer should ensure that all products in series production are in conformity with the product sample detailed in this report.

Prepared by:

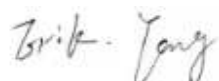

(Erik Yang)

Reviewed by:



(Jennifer Zhou)

Approved by:



(Authorized signatory: Echo Mu)

TEST REPORT

Report No.: SHE23120009-02DE

Date: 2024-02-01

Page 2 of 59

Contents

1	GENERAL INFORMATION	3
1.1	TESTING LABORATORY	3
1.2	DETAILS OF APPLICATION	3
1.3	DETAILS OF EUT	3
1.4	TEST METHODOLOGY	4
1.5	TEST SUMMARY	5
2	TEST CONDITION	6
2.1	ENVIRONMENTAL CONDITIONS	6
2.2	EQUIPMENT LIST	6
2.3	MEASUREMENT UNCERTAINTY	7
3	TEST SET-UP AND OPERATION MODES	8
3.1	DETAILS OF TEST MODE	8
3.2	SPECIAL ACCESSORIES AND AUXILIARY EQUIPMENT	8
3.3	SUPPORT SOFTWARE	8
3.4	TEST SETUP DIAGRAM	9
4	TEST RESULTS	11
4.1	TRANSMITTER REQUIREMENT & TEST SUITES	11
4.1.1	<i>Antenna Requirement</i>	11
4.1.2	<i>Maximum peak conducted output power and E.I.R.P</i>	12
4.1.3	<i>6dB Bandwidth and 99% Bandwidth</i>	17
4.1.4	<i>Maximum conducted output power spectral density</i>	24
4.1.5	<i>Conducted Spurious Emission & Authorized-band band-edge</i>	28
4.1.6	<i>Radiated Emission</i>	40
4.1.7	<i>Band Edge (Restricted-band band-edge)</i>	41
4.2	MAINS EMISSIONS	42
4.2.1	<i>Conducted Emission on AC Mains</i>	42
5	APPENDIXES	49
5.1	PHOTOGRAPHS OF THE SAMPLE	49
5.2	SET-UP FOR CONDUCTED EMISSIONS	55
5.3	SET-UP FOR CONDUCTED RF TEST AT ANTENNA PORT	56
5.4	SET-UP FOR SPURIOUS EMISSIONS BELOW 1GHZ	57
5.5	SET-UP FOR SPURIOUS EMISSIONS ABOVE 1GHZ	58

TEST REPORT

Report No.: SHE23120009-02DE

Date: 2024-02-01

Page 3 of 59

1 General Information

1.1 Testing Laboratory

ISED CAB identifier #	CN0081
Company Name	ICAS Testing Technology Service (Shanghai) Co., Ltd.
Address	No.1298 Pingan Road, Minhang District, Shanghai, China
Telephone	0086 21-51682999
Fax	0086 21-54711112
Homepage	www.icasiso.com

1.2 Details of Application

Applicant Company Name	Ehong Technology Co.,Ltd
Address	Room 501, No.485 Xingmei Road, Minhang Dis,Shanghai, China.
Contact Person	Rik Tang
Telephone	02164769993
Email	rik.tang@ehonglink.com
Manufacturer Company Name	Ehong Technology Co.,Ltd
Address	Room 501, No.485 Xingmei Road, Minhang Dis,Shanghai, China.
Factory Company Name	Ehong Technology Co.,Ltd
Address	Room 501, No.485 Xingmei Road, Minhang Dis,Shanghai, China.

1.3 Details of EUT

Product Name	BLE Module
Brand Name	Ehong
Test Model Name	EQM100-1B
Series Model Name	EQM100-1P, EQM100-1U
Difference Description	All the same except for the antenna type: EQM100-1B Model is the pcb antenna EQM100-1P Model is the pin antenna EQM100-1U Model is the external antenna
FCC ID	2ACCREQM1001
ISED Number	20625-EQM1001
Mode of Operation	Bluetooth BLE Version 5.4
Frequency Range	2402MHz ~ 2480MHz
Number of Channels	40 (at intervals of 2 MHz)
Modulation Type	BLE <input checked="" type="checkbox"/> GFSK 1Mbps <input checked="" type="checkbox"/> GFSK 2Mbps
Max RF Output Power-Conducted	6.44dBm
Antenna Type	EQM100-1B (PCB Antenna) EQM100-1U (External Antenna) EQM100-1P (PIN Antenna)

TEST REPORT

Report No.: SHE23120009-02DE

Date: 2024-02-01

Page 4 of 59

Antenna Gain	EQM100-1B (-1.34dBi) EQM100-1U (3.0dBi) EQM100-1P (1.99dBi)
Extreme Temperature Range	-10°C ~ +85°C
Test Voltage	DC 3.3V
Hardware Version	V2.0
Software Version	V1.0
RF power setting in TEST SW	sscom5.13.1_Power level setting_Default

Note:

1. The above information was declared by the manufacture.
2. For more details, please refer to the User's manual of the EUT.

Channel List

Channel	Frequency	Channel	Frequency	Channel	Frequency
0	2.402GHz	14	2.430GHz	28	2.458GHz
1	2.404GHz	15	2.432GHz	29	2.460GHz
2	2.406GHz	16	2.434GHz	30	2.462GHz
3	2.408GHz	17	2.436GHz	31	2.464GHz
4	2.410GHz	18	2.438GHz	32	2.466GHz
5	2.412GHz	19	2.440GHz	33	2.468GHz
6	2.414GHz	20	2.442GHz	34	2.470GHz
7	2.416GHz	21	2.444GHz	35	2.472GHz
8	2.418GHz	22	2.446GHz	36	2.474GHz
9	2.420GHz	23	2.448GHz	37	2.476GHz
10	2.422GHz	24	2.450GHz	38	2.478GHz
11	2.424GHz	25	2.452GHz	39	2.480GHz
12	2.426GHz	26	2.454GHz		
13	2.428GHz	27	2.456GHz		

1.4 Test Methodology

47 CFR Part 15, Subpart C	Telecommunication-Radio Frequency Devices-Intentional Radiators
KDB Publication 558074 D01 v05r02	15.247 Meas Guidance.
ANSI C63.10-2013	American National Standard for Testing Unlicensed Wireless Devices
RSS-Gen (Issue 5, Amd.2-Feb 2021)	General Requirements for Compliance of Radio Apparatus
RSS-247 (Issue 3, August 2023)	Digital Transmission Systems (DTSs), Frequency Hopping Systems (FHSs) and Licence-Exempt Local Area Network (LE-LAN) Devices

Note(s):

All test items were verified and recorded according to the standards and without any addition/deviation/exclusion during the test.

TEST REPORT

Report No.: SHE23120009-02DE

Date: 2024-02-01

Page 5 of 59

1.5 Test Summary

Test Item	FCC Rules	ISED Rules	Result
Antenna Requirement	FCC Part 15.247(b)(4), Part 15.203	RSS-247 5.4(f) RSS-GEN 6.8	PASS
Maximum peak conducted output power and E.I.R.P	FCC Part 15.247(b)(3)	RSS-247 5.4(d)	PASS
6dB Bandwidth and 99% Bandwidth	FCC Part 15.247(a)(2)	RSS-247 5.2(a) RSS-Gen 6.7	PASS
Maximum conducted output power spectral density	FCC Part 15.247(e)	RSS-247 5.2(b)	PASS
Conducted Spurious Emission & Authorized-band band-edge	FCC Part 15.247(d)	RSS-247 5.5	PASS
Radiated Emission	FCC Part 15.247(d), 15.205, 15.209	RSS-GEN 8.9	PASS
Band Edge (Restricted-band band-edge)	FCC Part 15.247(d), 15.205, 15.209	RSS-GEN 8.10	PASS
Conducted Emission on AC Mains	FCC Part 15.207(a)	RSS-Gen 8.8	PASS

TEST REPORT

Report No.: SHE23120009-02DE

Date: 2024-02-01

Page 6 of 59

2 Test Condition

2.1 Environmental conditions

Temperature (°C)	18-25
Humidity (%RH)	40-65
Barometric Pressure (mbar)	960-1060

2.2 Equipment List

Name of Equipment	Manufacturer	Model	Serial No.	Cal. Date	Cal. Due
Spectrum Analyzer	Keysight	N9020B	MY59260184	2023-07-27	2024-07-26
Spectrum Analyzer	Rohde & Schwarz	FSV40N	101450	2023-06-08	2024-06-07
Signal Generator	Rohde & Schwarz	SMR27	100184	2023-07-27	2024-07-26
EMI Test Receiver	Rohde & Schwarz	ESPI3	100173	2023-06-08	2024-06-07
EMI Test Receiver	Rohde & Schwarz	ESR 7	101911	2023-06-08	2024-06-07
V-network	SCHWARZBECK	NSLK 8127	8127-902	2023-06-07	2024-06-06
Attenuator	SCHWARZBECK	VTSD 9561-FN	/	2023-06-06	2024-06-05
Broadband Antenna	SCHWARZBECK	VULB9163	9163-1037	2023-03-22	2025-03-21
Horn Antenna-18G	SCHWARZBECK	BBHA9120D	9120D-1775	2023-06-13	2025-06-12
Loop Antenna	SCHWARZBECK	FMZB 1513	/	2023-06-09	2024-06-08
Horn Antenna-40G	YINGLIAN	LB-180400-KF	N/A	2023-06-18	2025-06-17
Broadband Preamplifier	SCHWARZBECK	BBV 9718	346	2023-06-08	2024-06-07
EMC chamber 9*6*6(L*W*H)	CHANGNING	966	N/A	2023-06-09	2024-06-08
Shielded Enclosure 8*5*4(L*W*H)	CHANGNING	854	N/A	2023-06-09	2025-06-08
Test Software	BL	BL410_E	Version:2.1.1.436	N/A	N/A
Test Software	BL	BL410_R	Version:2.1.1.409	N/A	N/A

TEST REPORT

Report No.: SHE23120009-02DE

Date: 2024-02-01

Page 7 of 59

2.3 Measurement Uncertainty

The uncertainty is calculated using the methods suggested in the “Guide to the Expression of Uncertainty in measurement” (GUM) published by CISPR and ANSI. The reported uncertainty of measurement $y \pm U$, where expanded uncertainty U is based on a standard uncertainty multiplied by a coverage factor of $k=2$, providing a level of confidence of approximately 95.45%.

Parameter		Uncertainty
Antenna Port Conducted Emission	< 1GHz	± 1.5 dB
	> 1GHz	± 1.5 dB
Radiated Emission	9KHz – 30MHz	± 3.42 dB
	30 MHz – 1GHz	± 5.00 dB
	> 1GHz	± 4.88 dB
Conducted Emission on AC Mains	150kHz-30MHz	± 2.68 dB
Occupied Channel Bandwidth		± 5 %
Maximum Conducted Output Power and E.I.R.P		± 0.64 dB
Maximum Conducted Output Power Spectral Density		± 1.18 dB

TEST REPORT

Report No.: SHE23120009-02DE

Date: 2024-02-01

Page 8 of 59

3 Test Set-up and Operation Modes

3.1 Details of Test Mode

Using test software was control EUT work in continuous transmitting mode. Select test channel as below:

Channel	Frequency
The lowest channel(CH00)	2402MHz
The middle channel(CH19)	2440MHz
The Highest channel(CH39)	2480MHz

The basic operation modes are:

- A. On
 - 1. BLE mode
 - a. Transmitting
 - i. Low Channel
 - ii. Middle Channel
 - iii. High Channel
 - b. Receiving
 - 2. Normal working with Bluetooth on
- B. Standby
- C. Off

3.2 Special Accessories and Auxiliary Equipment

Description	Manufacturer	Model Name	Serial No.
Laptop 1	Lenovo	TP00083A	PF-0PRDGN
Laptop 2	HP	HP ZHAN 66 PRO G1	5CD7438R1G
USB Cable	N/A	N/A	1.00m Unshielded

3.3 Support Software

Description	Manufacturer	Software Name
Software	N/A	sscom5.13.1

TEST REPORT

Report No.: SHE23120009-02DE

Date: 2024-02-01

Page 9 of 59

3.4 Test Setup Diagram

Diagram of Measurement Configuration for Radiation Test

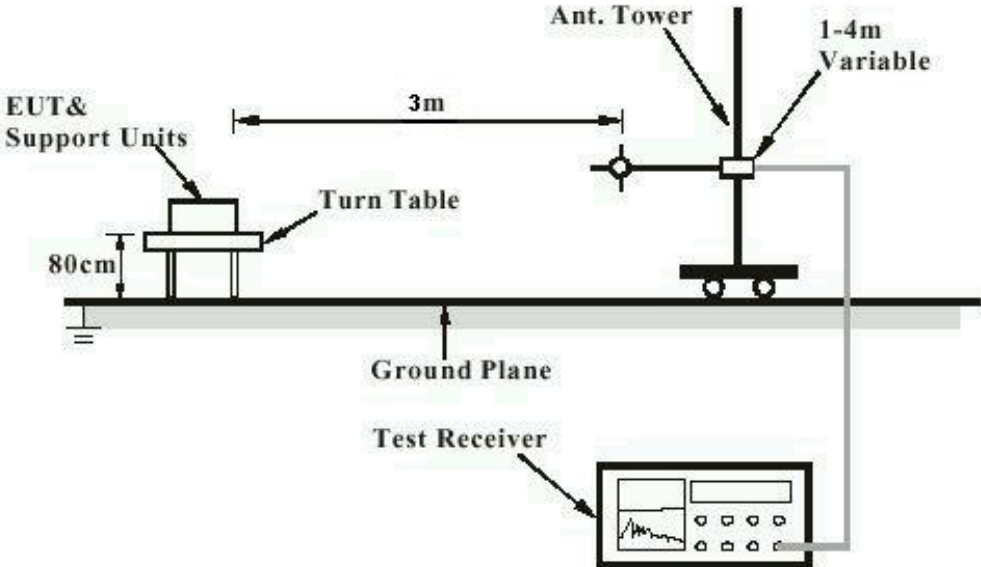

Note: Measurements above 1GHz are done with a table height of 1.5m. In addition, there is RF absorbing material on the floor of the test site for above 1GHz measurement.

Diagram of Measurement Equipment Configuration for Conduction Measurement

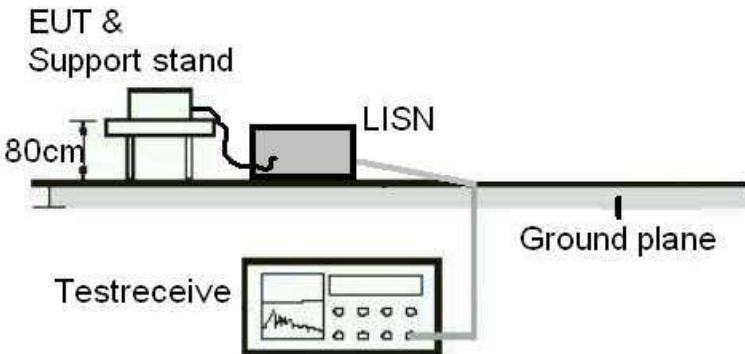

TEST REPORT

Report No.: SHE23120009-02DE

Date: 2024-02-01

Page 10 of 59

Diagram of Measurement Equipment Configuration for Transmitter Test

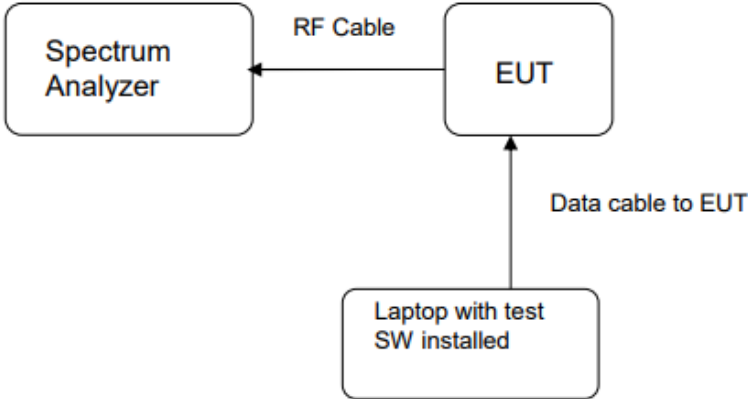

TEST REPORT

Report No.: SHE23120009-02DE

Date: 2024-02-01

Page 11 of 59

4 Test Results

4.1 Transmitter Requirement & Test Suites

4.1.1 Antenna Requirement

RESULT:

PASS

Test standard	: FCC Part 15.247(b)(4), Part 15.203 RSS-247 5.4(f), RSS-GEN 6.8
Requirement	: An intentional radiator shall be designed to ensure that no antenna other than that furnished by the responsible party shall be used with the device. The use of a permanently attached antenna or of an antenna that uses a unique coupling to the intentional radiator shall be considered sufficient to comply with the provisions of this section. The manufacturer may design the unit so that a broken antenna can be replaced by the user, but the use of a standard antenna jack or electrical connector is prohibited. In addition, If transmitting antennas of directional gain greater than 6dBi are used, both the maximum conducted output power and the maximum power spectral density shall be reduced by the amount in dB that the directional gain of the antenna exceeds 6dBi.

According to the manufacturer declaration, The EUT (EQM100-1B) has an antenna with a directional gain of -1.34dBi. The antenna is PCB antenna with no possibility of replacement with a non-approved antenna by the end-user.

The EUT (EQM100-1U) has an antenna with a directional gain of 3.00dBi. The antenna is an external antenna with no possibility of replacement with a non-approved antenna by the end-user.

The EUT (EQM100-1P) has an antenna with a directional gain of 1.99dBi. The antenna is PIN Antenna with no possibility of replacement with a non-approved antenna by the end-user.

The manufacturer may design the unit so that a broken antenna can be replaced by the user, but the use of a standard antenna jack or electrical connector is prohibited.

Therefore, the EUT is considered to comply with this provision.

TEST REPORT

Report No.: SHE23120009-02DE

Date: 2024-02-01

Page 12 of 59

4.1.2 Maximum peak conducted output power and E.I.R.P

RESULT:

PASS

Test standard : FCC Part 15.247(b)(3), RSS-247 5.4(d)
 Requirement : ANSI C63.10-2013 clause 11.9.1.1,
 KDB 558074 D01 v05r02, Clause 8.3.1
 Kind of test site : Shielded room

Test setup

Test Channel : Low/Middle/High
 Operation Mode : A.1.a
 Ambient temperature : 22.7°C
 Relative humidity : 50%

Table 1: Maximum peak conducted output power

Test Mode	Test Channel (MHz)	Maximum peak conducted output power		Limit (W)
		(dBm)	(mW)	
BLE-1Mbps	2402	6.44	4.41	< 1
	2440	6.27	4.24	
	2480	6.05	4.03	
BLE-2Mbps	2402	6.30	4.27	< 1
	2440	6.12	4.09	
	2480	5.95	3.94	

Table 2: E.I.R.P_Model: EQM100-1B

Test Mode	Test Channel (MHz)	E.I.R.P		Limit (W)
		(dBm)	(mW)	
BLE-1Mbps	2402	5.10	3.24	< 4
	2440	4.93	3.11	
	2480	4.71	2.96	
BLE-2Mbps	2402	4.96	3.13	
	2440	4.78	3.01	
	2480	4.61	2.89	

TEST REPORT

Report No.: SHE23120009-02DE

Date: 2024-02-01

Page 13 of 59

Table 3: E.I.R.P_Model: EQM100-1P

Test Mode	Test Channel (MHz)	E.I.R.P		Limit (W)
		(dBm)	(mW)	
BLE-1Mbps	2402	8.43	6.97	< 4
	2440	8.26	6.70	
	2480	8.04	6.37	
BLE-2Mbps	2402	8.29	6.75	
	2440	8.11	6.47	
	2480	7.94	6.22	

Table 4: E.I.R.P_Model: EQM100-1U

Test Mode	Test Channel (MHz)	E.I.R.P		Limit (W)
		(dBm)	(mW)	
BLE-1Mbps	2402	9.44	8.79	< 4
	2440	9.27	8.45	
	2480	9.05	8.04	
BLE-2Mbps	2402	9.30	8.51	
	2440	9.12	8.17	
	2480	8.95	7.85	

Note: The antenna gain (EQM100-1B:-1.34dBi, EQM100-1P:1.99dBi; EQM100-1U:3.00dBi)

E.I.R.P= peak conducted output power+antenna gain

TEST REPORT

Report No.: SHE23120009-02DE

Date: 2024-02-01

Page 14 of 59

Figure 1: Peak Output Power, 2402MHz, BLE-1Mbps



Figure 2: Peak Output Power, 2440MHz, BLE-1Mbps



TEST REPORT

Report No.:

SHE23120009-02DE

Date:

2024-02-01

Page 15 of 59

Figure 3: Peak Output Power, 2480MHz, BLE-1Mbps

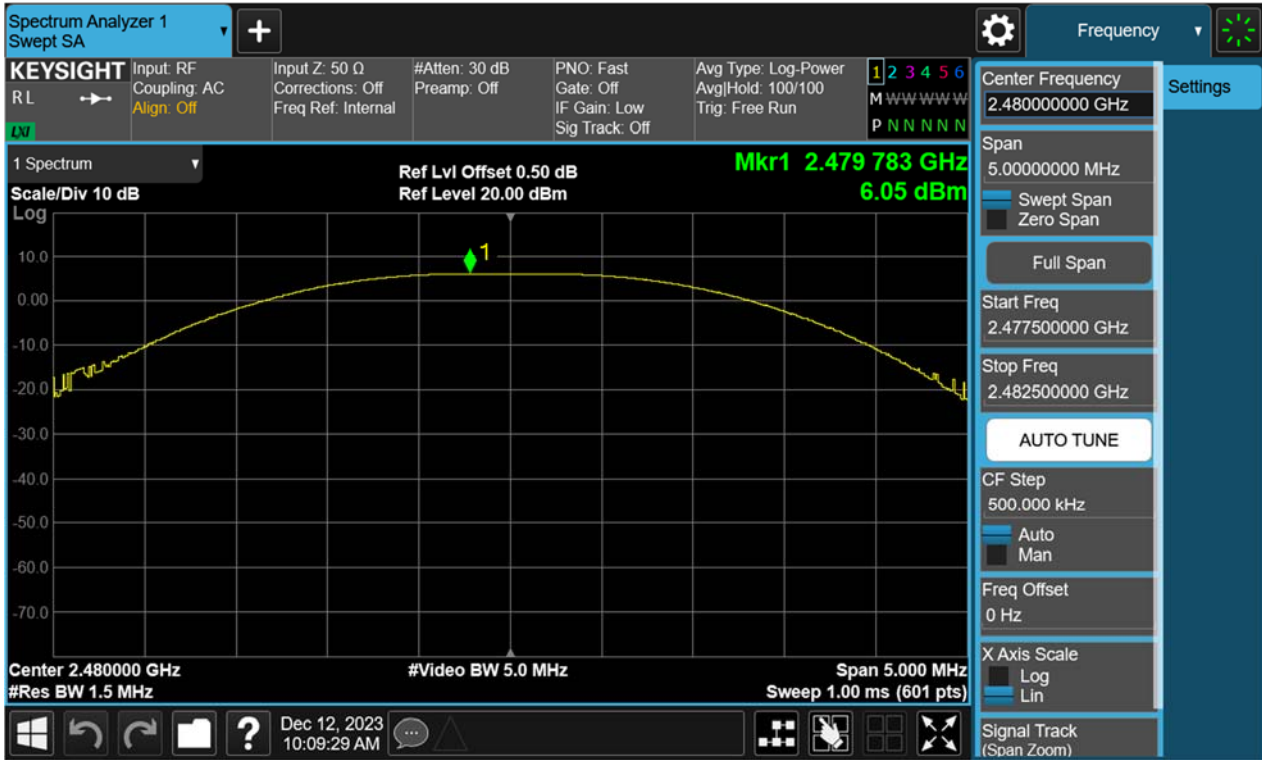
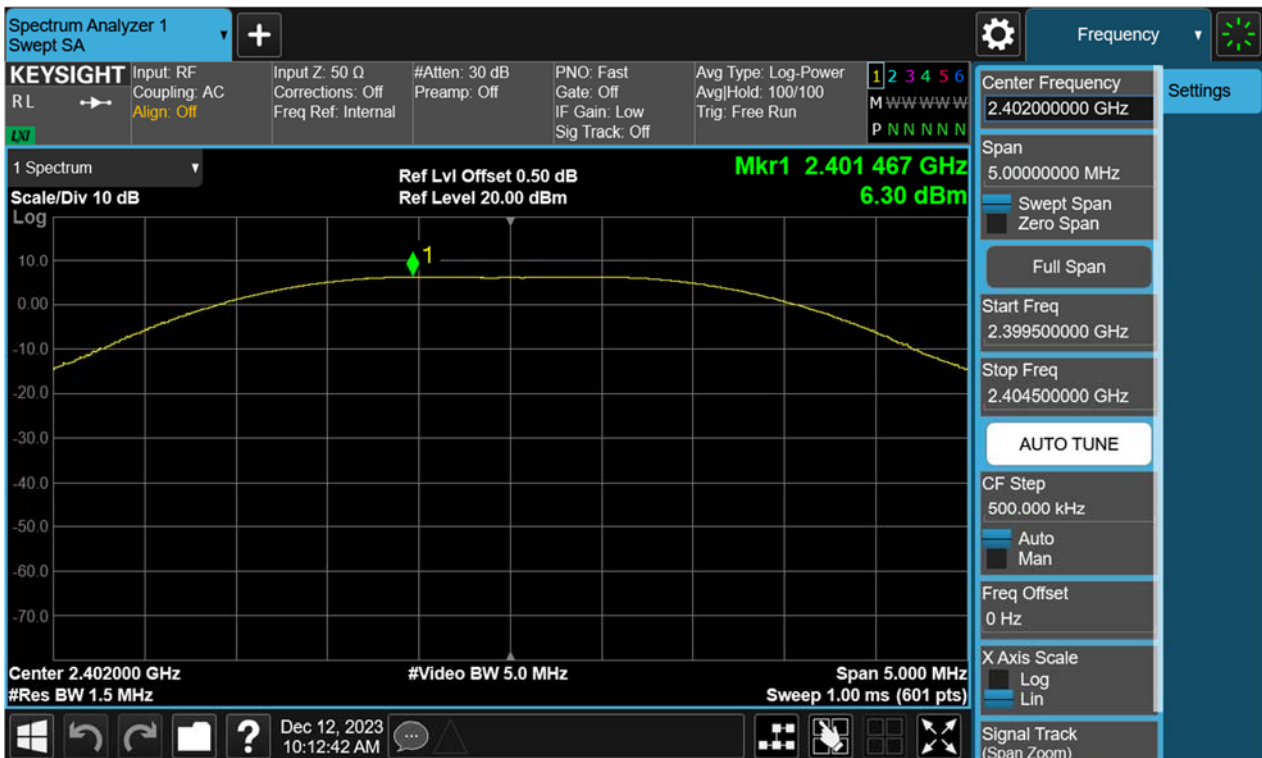

Figure 4: Peak Output Power, 2402MHz, BLE-2Mbps



TEST REPORT

Report No.:

SHE23120009-02DE

Date:

2024-02-01

Page 16 of 59

Figure 5: Peak Output Power, 2440MHz, BLE-2Mbps



Figure 6: Peak Output Power, 2480MHz, BLE-2Mbps

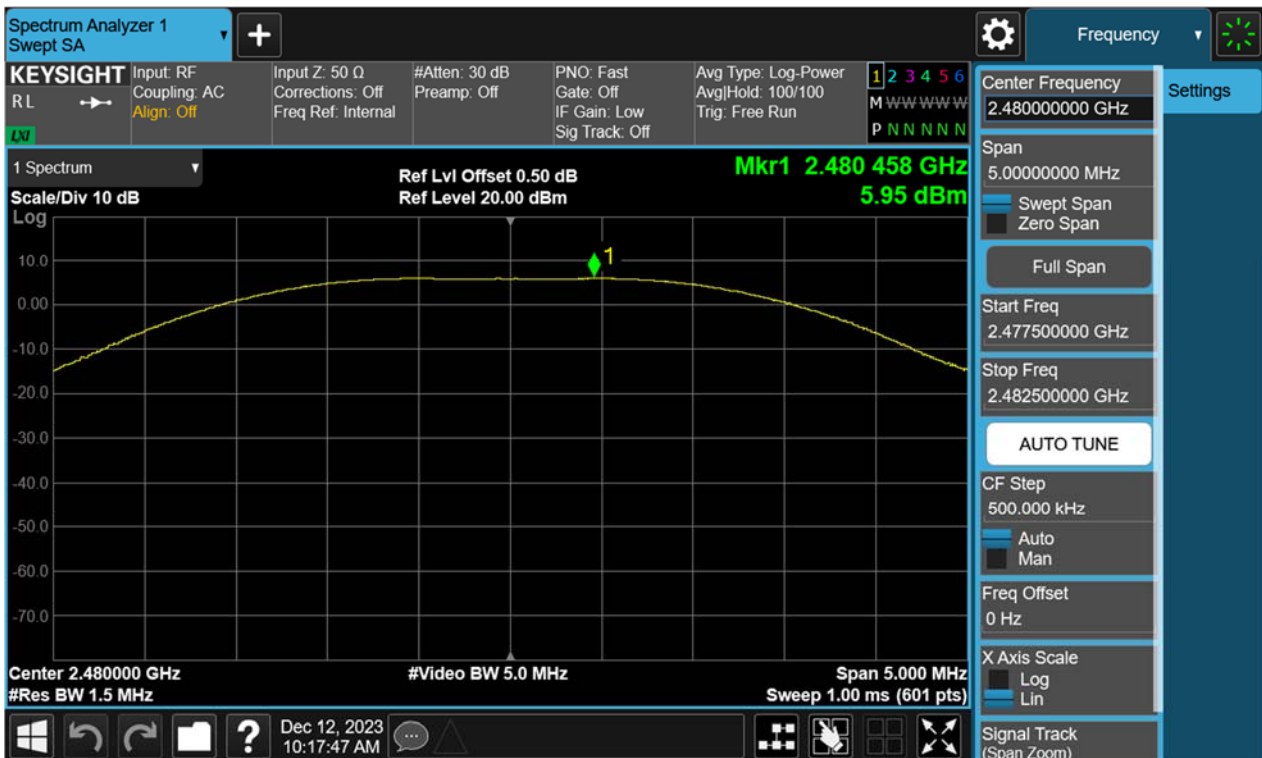

TEST REPORT

Report No.: SHE23120009-02DE

Date: 2024-02-01

Page 17 of 59

4.1.3 6dB Bandwidth and 99% Bandwidth

RESULT:

PASS

Test standard : FCC Part 15.247(a)(2), RSS-247 5.2(a)
RSS-Gen 6.7
Requirement : ANSI C63.10-2013 clause 11.8.1,
KDB 558074 D01 v05r02, Clause 8.2
Kind of test site : Shielded room

Test setup

Test Channel : Low/Middle/High
Operation Mode : A.1.a
Ambient temperature : 22.7°C
Relative humidity : 50%

Table 5: 6dB Bandwidth and 99% Bandwidth

Test Mode	Test Channel (MHz)	6dB Bandwidth (MHz)	99% Bandwidth (MHz)	6dB Bandwidth Limit
BLE-1Mbps	2402	0.6920	1.0437	>0.5 MHz
	2440	0.7095	1.0336	
	2480	0.7231	1.0429	
BLE-2Mbps	2402	1.2070	2.0524	
	2440	1.1640	2.0415	
	2480	1.2190	2.0458	

TEST REPORT

Report No.: SHE23120009-02DE

Date: 2024-02-01

Page 18 of 59

Figure 7: 6dB Bandwidth, 2402MHz, BLE-1Mbps



99% Bandwidth, 2402MHz, BLE-1Mbps

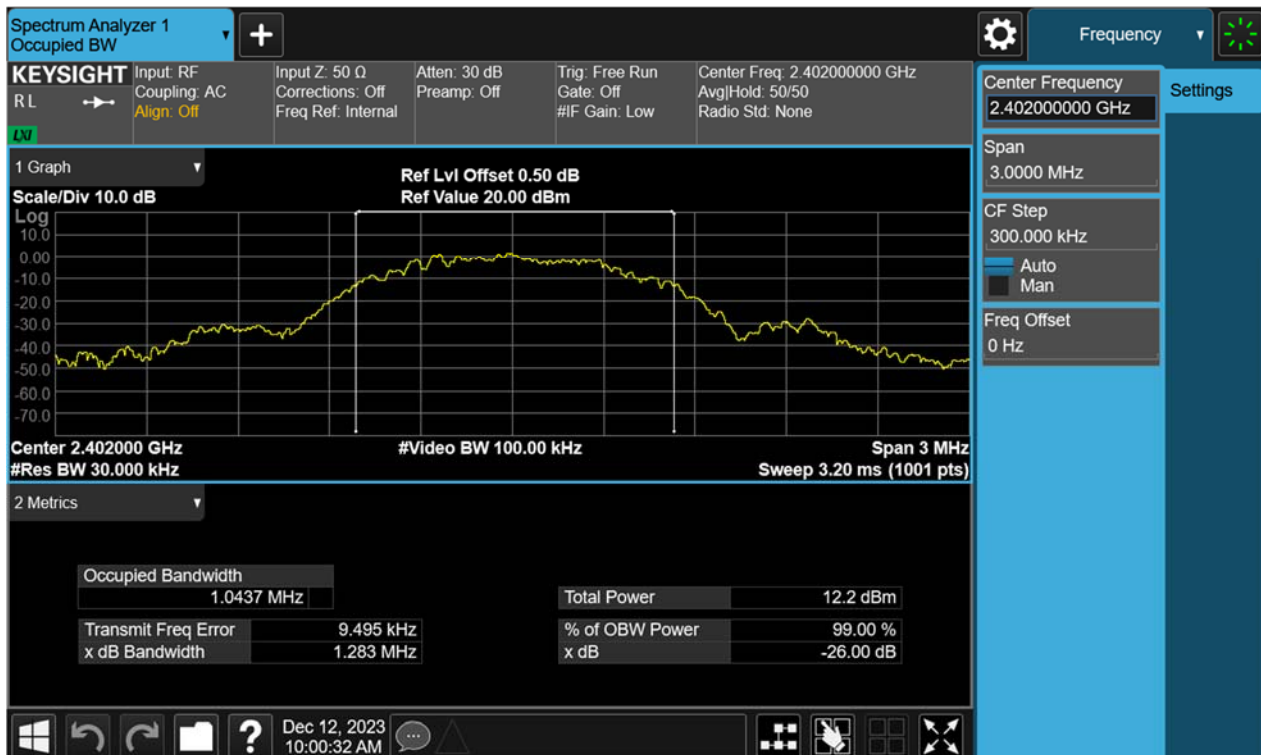

TEST REPORT

Report No.: SHE23120009-02DE

Date: 2024-02-01

Page 19 of 59

Figure 8: 6dB Bandwidth, 2440MHz, BLE-1Mbps



99% Bandwidth, 2440MHz, BLE-1Mbps



TEST REPORT

Report No.: SHE23120009-02DE

Date: 2024-02-01

Page 20 of 59

Figure 9: 6dB Bandwidth, 2480MHz, BLE-1Mbps



99% Bandwidth, 2480MHz, BLE-1Mbps



TEST REPORT

Report No.: SHE23120009-02DE

Date: 2024-02-01

Page 21 of 59

Figure 10: 6dB Bandwidth, 2402MHz, BLE-2Mbps

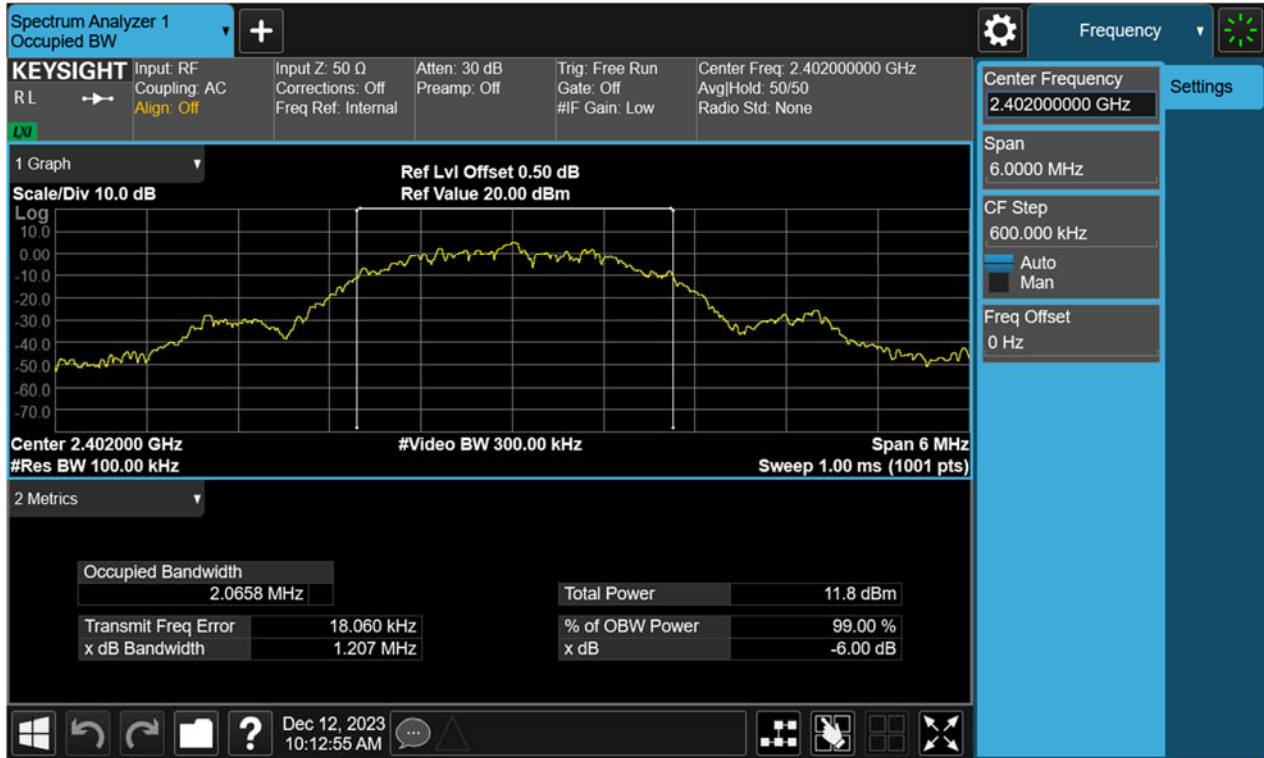

99% Bandwidth, 2402MHz, BLE-2Mbps



TEST REPORT

Report No.: SHE23120009-02DE

Date: 2024-02-01

Page 22 of 59

Figure 11: 6dB Bandwidth, 2440MHz, BLE-2Mbps



99% Bandwidth, 2440MHz, BLE-2Mbps



TEST REPORT

Report No.: SHE23120009-02DE

Date: 2024-02-01

Page 23 of 59

Figure 12: 6dB Bandwidth, 2480MHz, BLE-2Mbps



99% Bandwidth, 2480MHz, BLE-2Mbps



TEST REPORT

Report No.: SHE23120009-02DE

Date: 2024-02-01

Page 24 of 59

4.1.4 Maximum conducted output power spectral density

RESULT:

PASS

Test standard : FCC Part 15.247(e), RSS-247 5.2(b)
Requirement : ANSI C63.10-2013 clause 11.10.2,
KDB 558074 D01 v05r02, Clause 8.4
Kind of test site : Shielded room

Test setup

Test Channel : Low/Middle/High
Operation Mode : A.1.a
Ambient temperature : 22.7°C
Relative humidity : 50%

Table 4: Maximum conducted output power spectral density

Test Mode	Test Channel (MHz)	Measured Result (dBm/3kHz)	Limit (dBm/3kHz)
BLE-1Mbps	2402	-8.68	8
	2440	-8.82	
	2480	-8.89	
BLE-2Mbps	2402	-12.50	
	2440	-12.62	
	2480	-12.65	

TEST REPORT

Report No.: SHE23120009-02DE

Date: 2024-02-01

Page 25 of 59

Figure 13: Power Spectral Density, 2402MHz, BLE-1Mbps



Figure 14: Power Spectral Density, 2440MHz, BLE-1Mbps

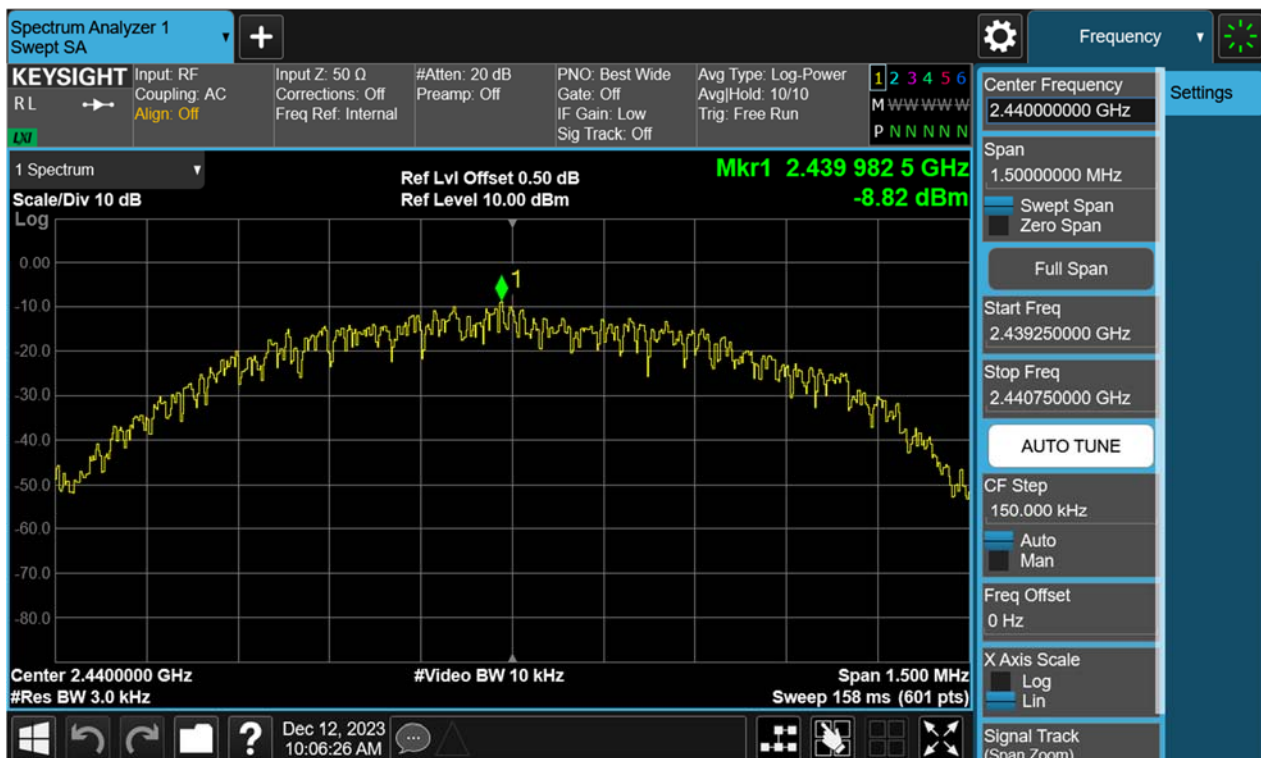

TEST REPORT

Report No.: SHE23120009-02DE

Date: 2024-02-01

Page 26 of 59

Figure 15: Power Spectral Density, 2480MHz, BLE-1Mbps

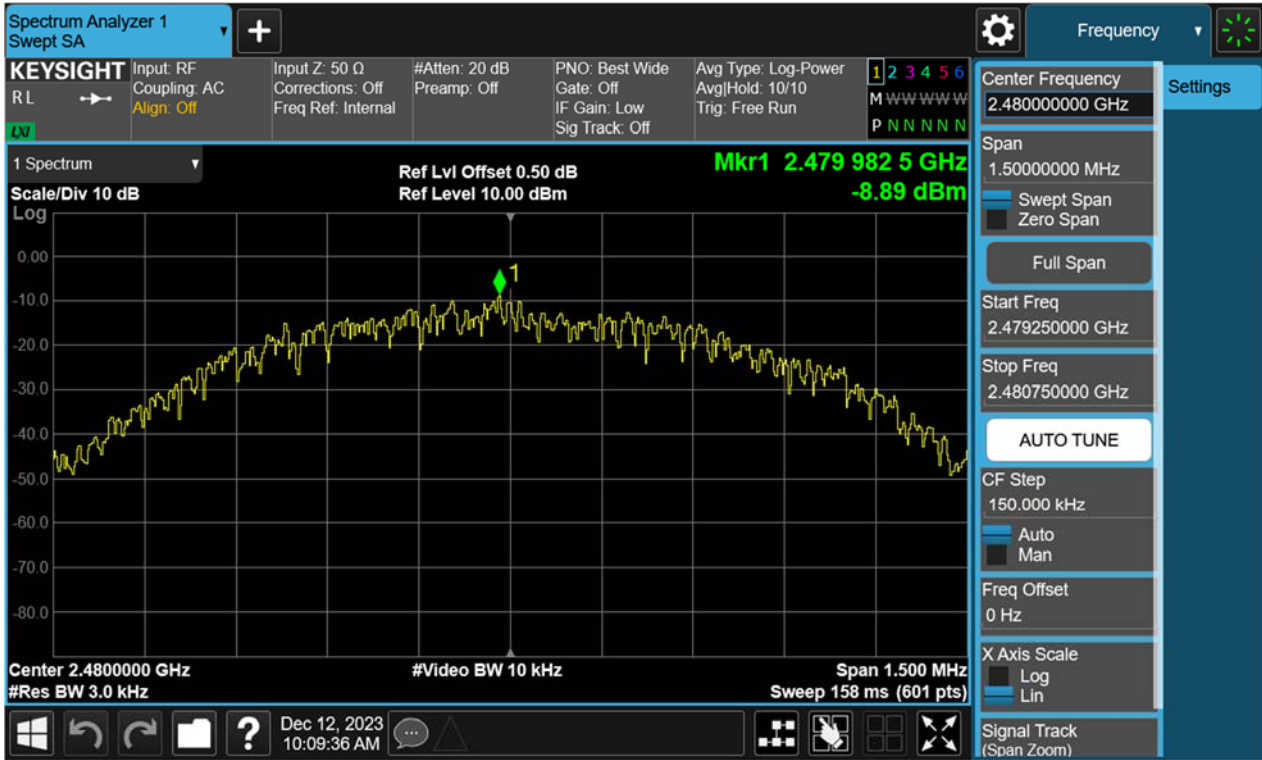
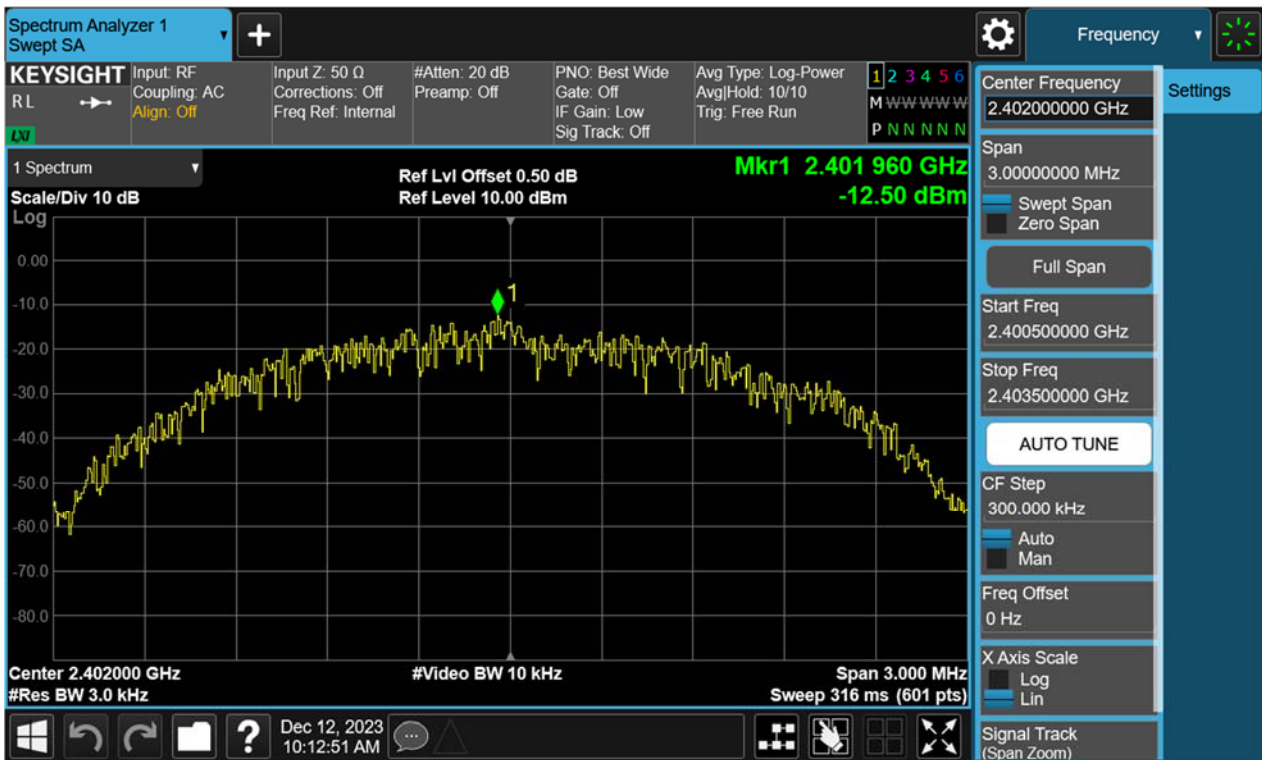

Figure 16: Power Spectral Density, 2402MHz, BLE-2Mbps



TEST REPORT

Report No.: SHE23120009-02DE

Date: 2024-02-01

Page 27 of 59

Figure 17: Power Spectral Density, 2440MHz, BLE-2Mbps

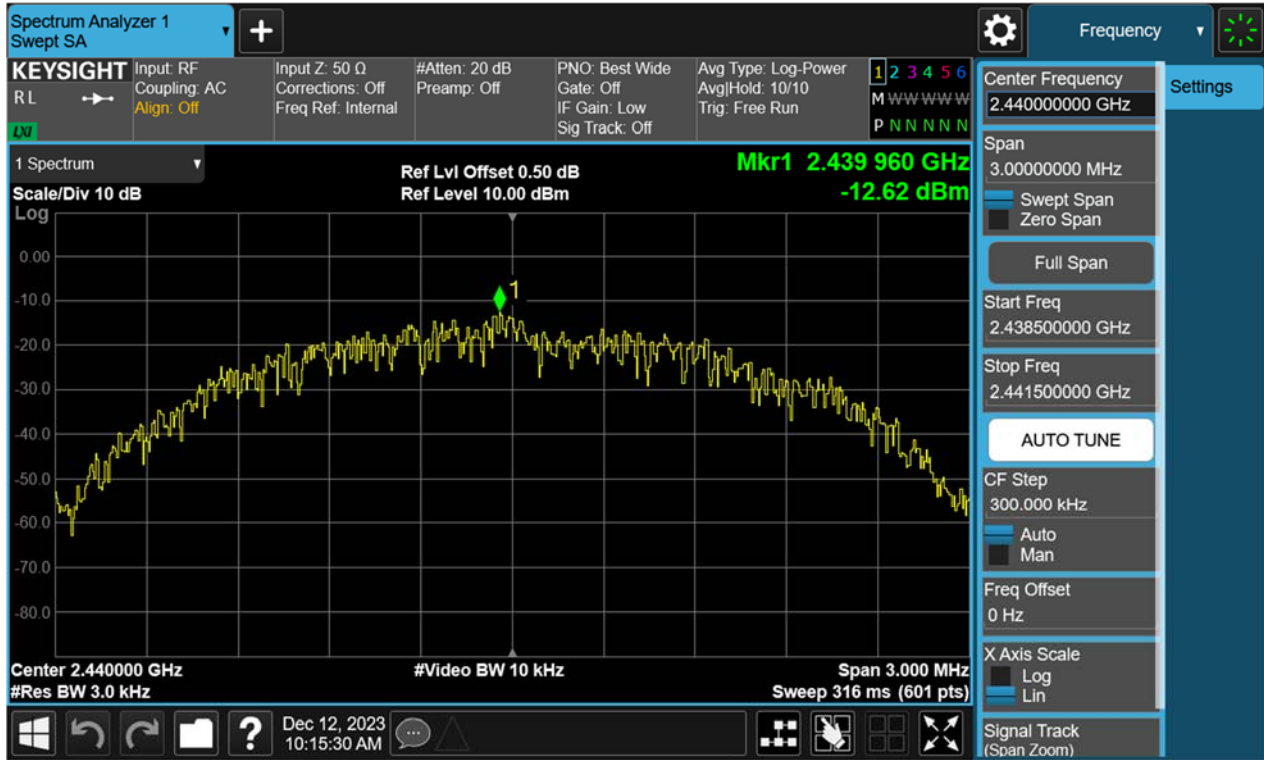
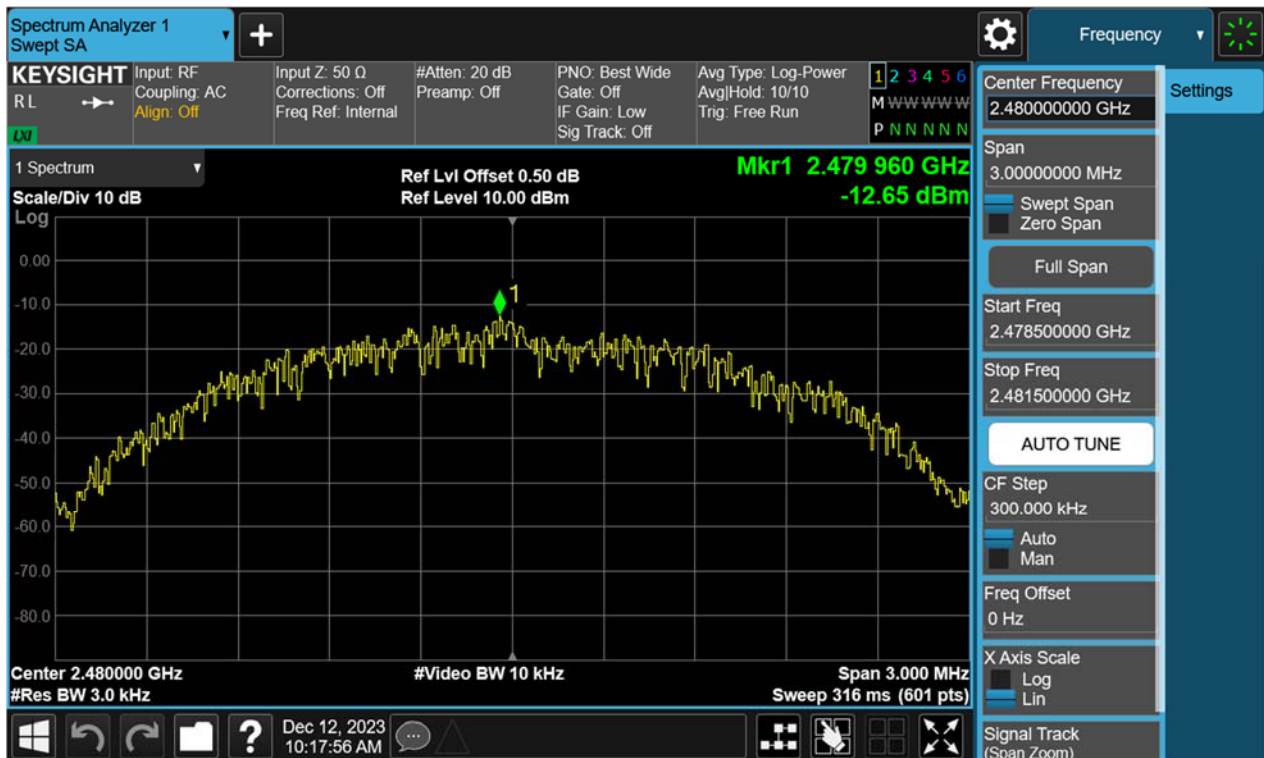

Figure 18: Power Spectral Density, 2480MHz, BLE-2Mbps



TEST REPORT

Report No.: SHE23120009-02DE

Date: 2024-02-01

Page 28 of 59

4.1.5 Conducted Spurious Emission & Authorized-band band-edge

RESULT:

PASS

Test standard : FCC Part 15.247(d), RSS-247 5.5
Requirement : ANSI C63.10-2013, Clause 11.11.1(a)
KDB 558074 D01 v05r02, Clause 8.5
Kind of test site : Shielded room

Test setup

Test Channel : Low/Middle/High for spurious, Low/High for Band
Edge
Operation Mode : A.1.a
Ambient temperature : 22.7°C
Relative humidity : 50%

For details refer to following test plot.

TEST REPORT

Report No.:

SHE23120009-02DE

Date:

2024-02-01

Page 29 of 59

Figure 19: Conducted Spurious Emission & Authorized-band band-edge, 2402MHz, BLE-1Mbps Carrier Level



Band Edge

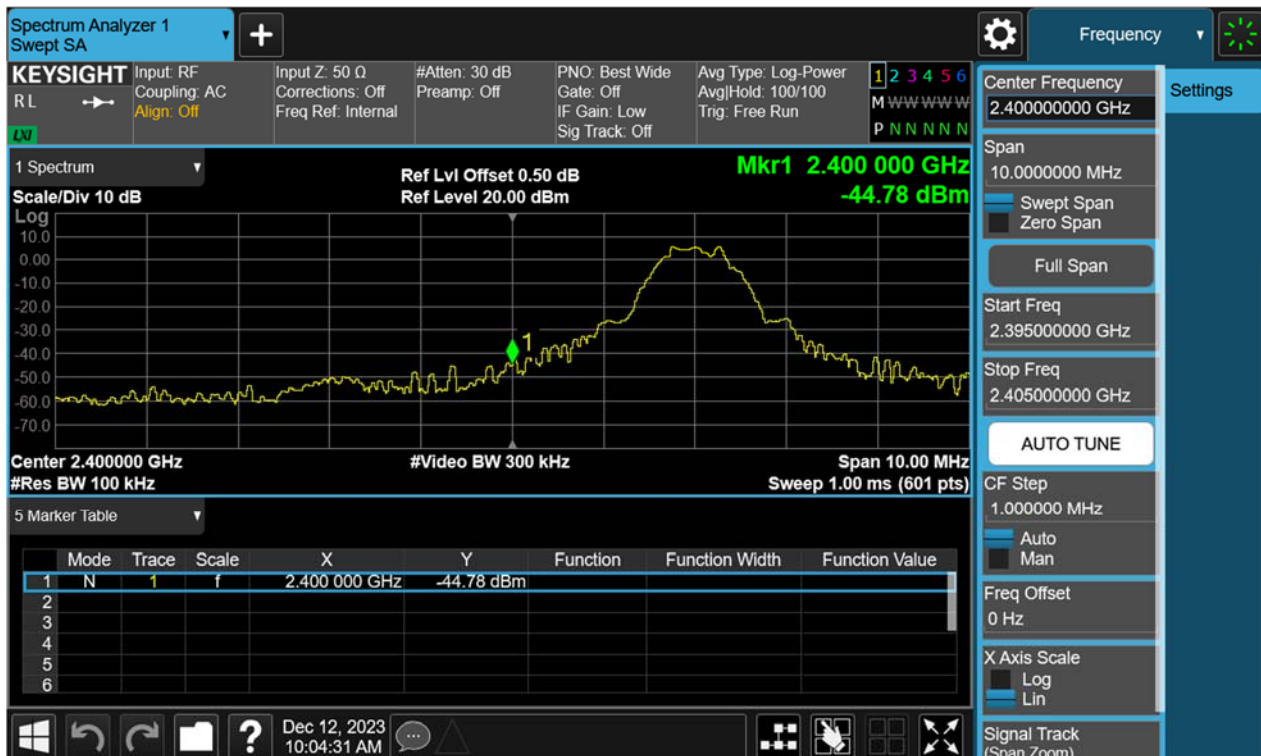

TEST REPORT

Report No.:

SHE23120009-02DE

Date:

2024-02-01

Page 30 of 59

Conducted spurious emissions 30MHz-25GHz

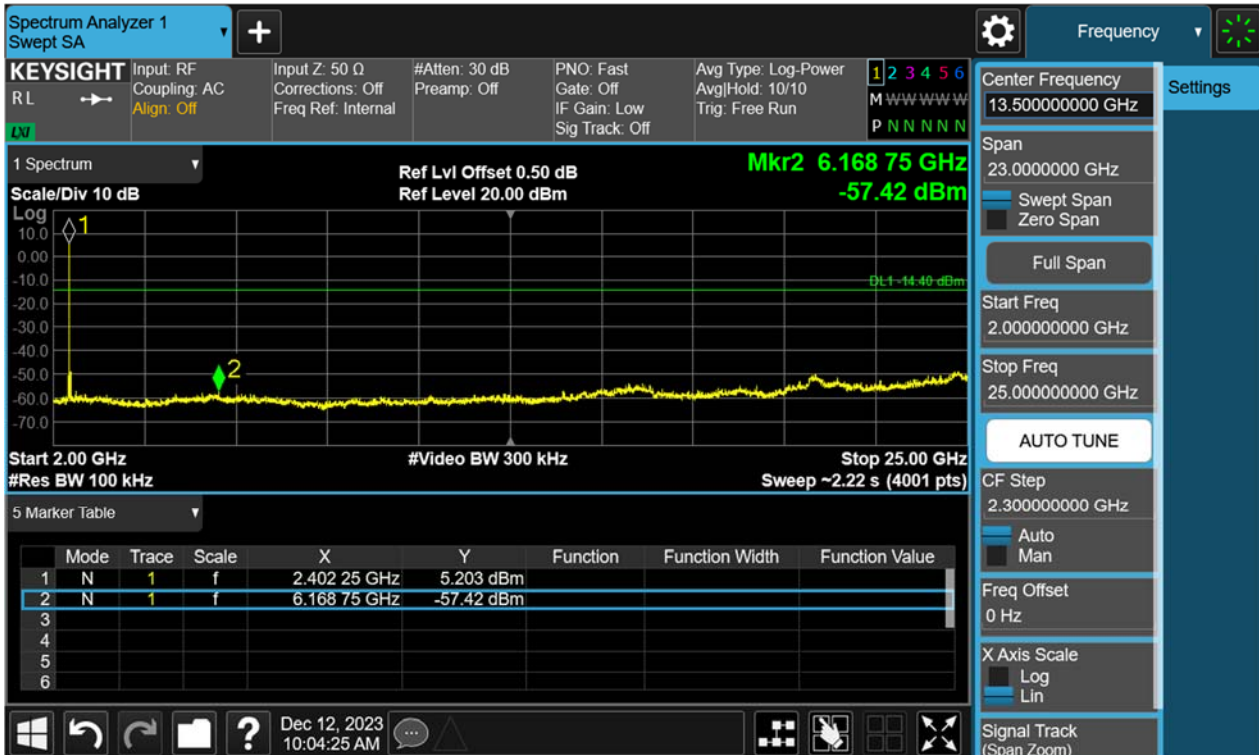
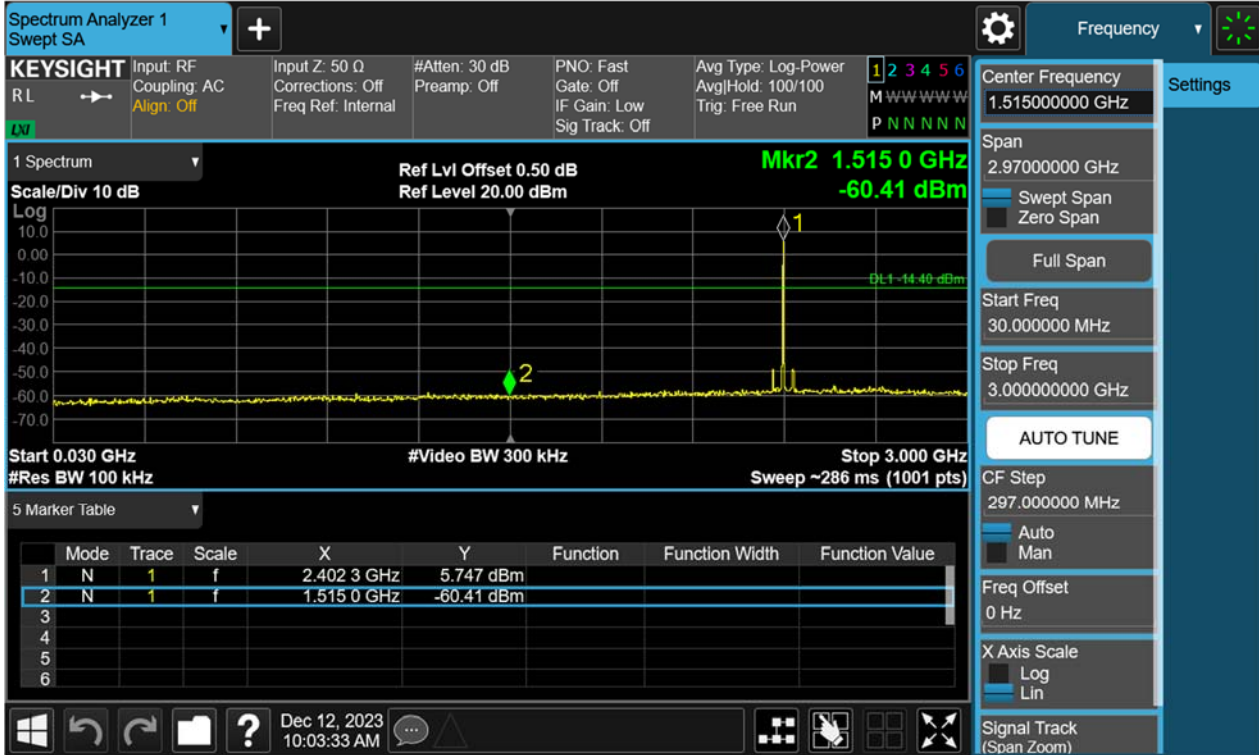

TEST REPORT

Report No.: SHE23120009-02DE

Date: 2024-02-01

Page 31 of 59

Figure 20: Conducted Spurious Emission & Authorized-band band-edge, 2440MHz, BLE-1Mbps Carrier Level



Conducted spurious emissions 30MHz-25GHz

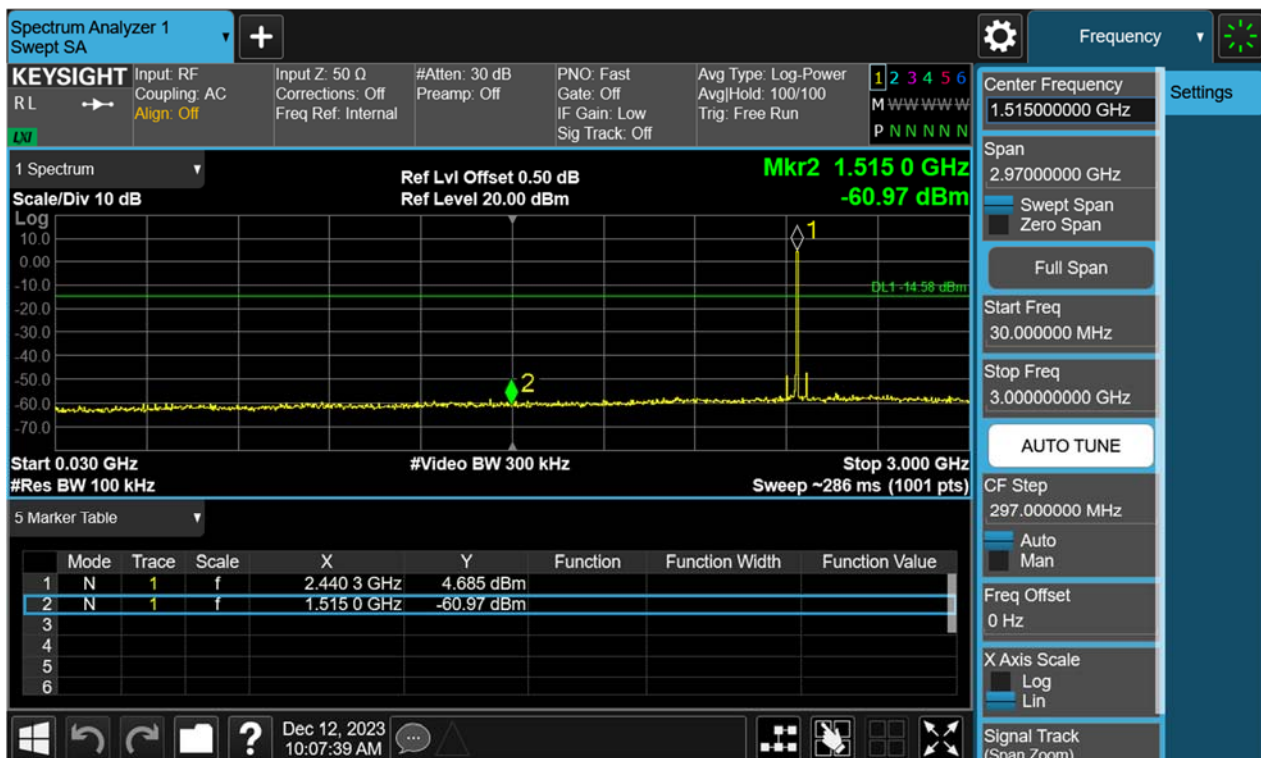

TEST REPORT

Report No.:

SHE23120009-02DE

Date:

2024-02-01

Page 32 of 59



Figure 21: Conducted Spurious Emission & Authorized-band band-edge, 2480MHz, BLE-1Mbps Carrier Level



TEST REPORT

Report No.:

SHE23120009-02DE

Date:

2024-02-01

Page 33 of 59

Band Edge



Conducted spurious emissions 30MHz-25GHz

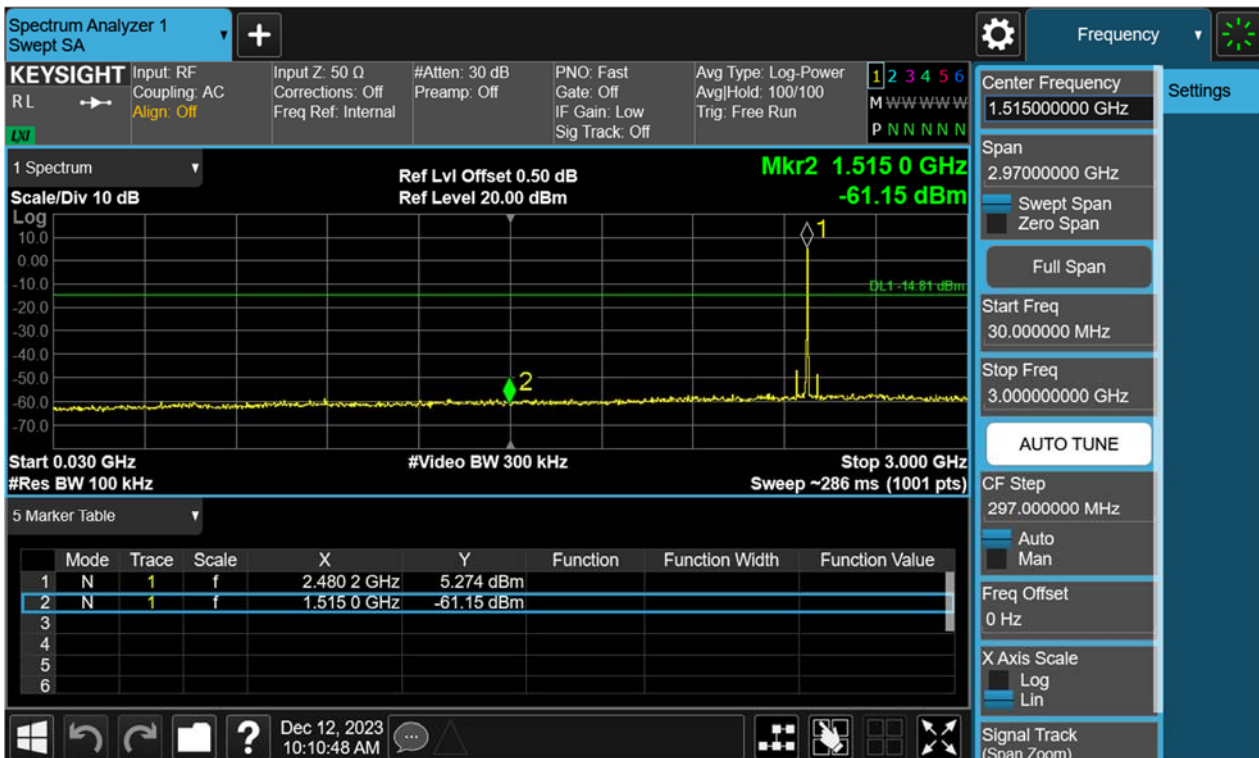

TEST REPORT

Report No.:

SHE23120009-02DE

Date:

2024-02-01

Page 34 of 59

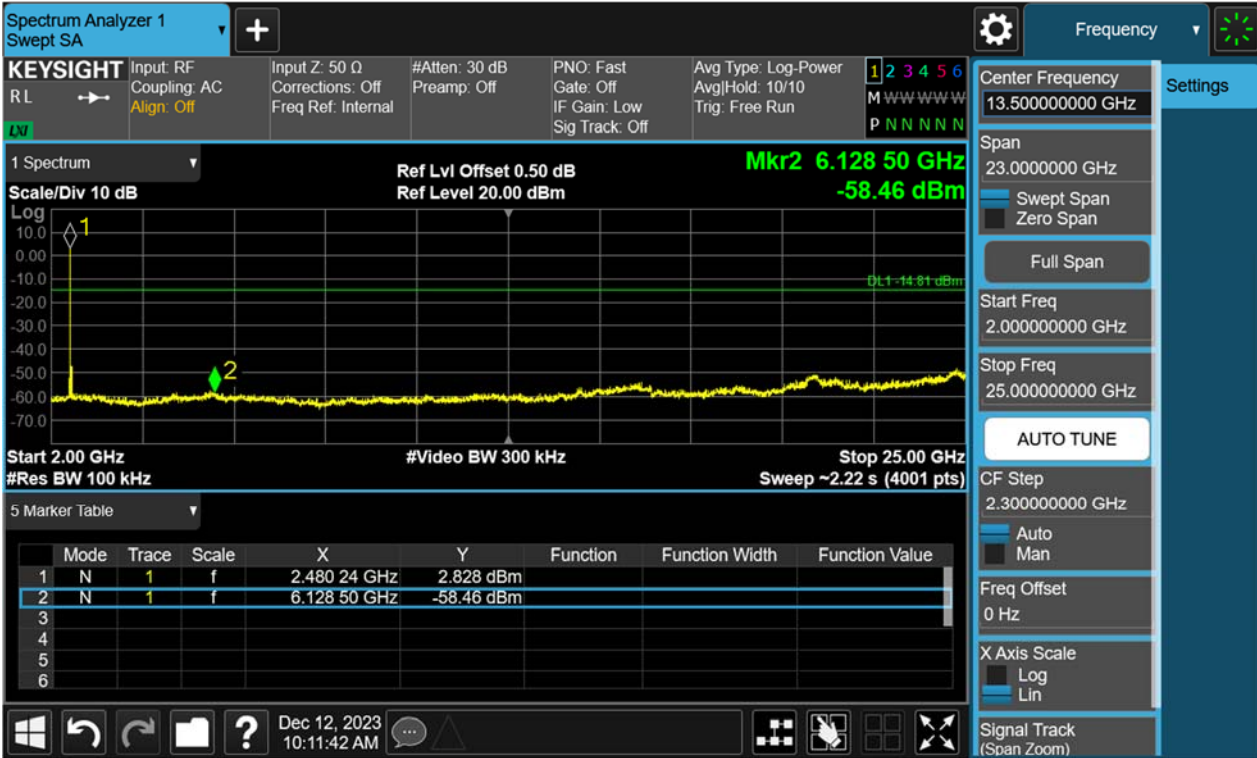
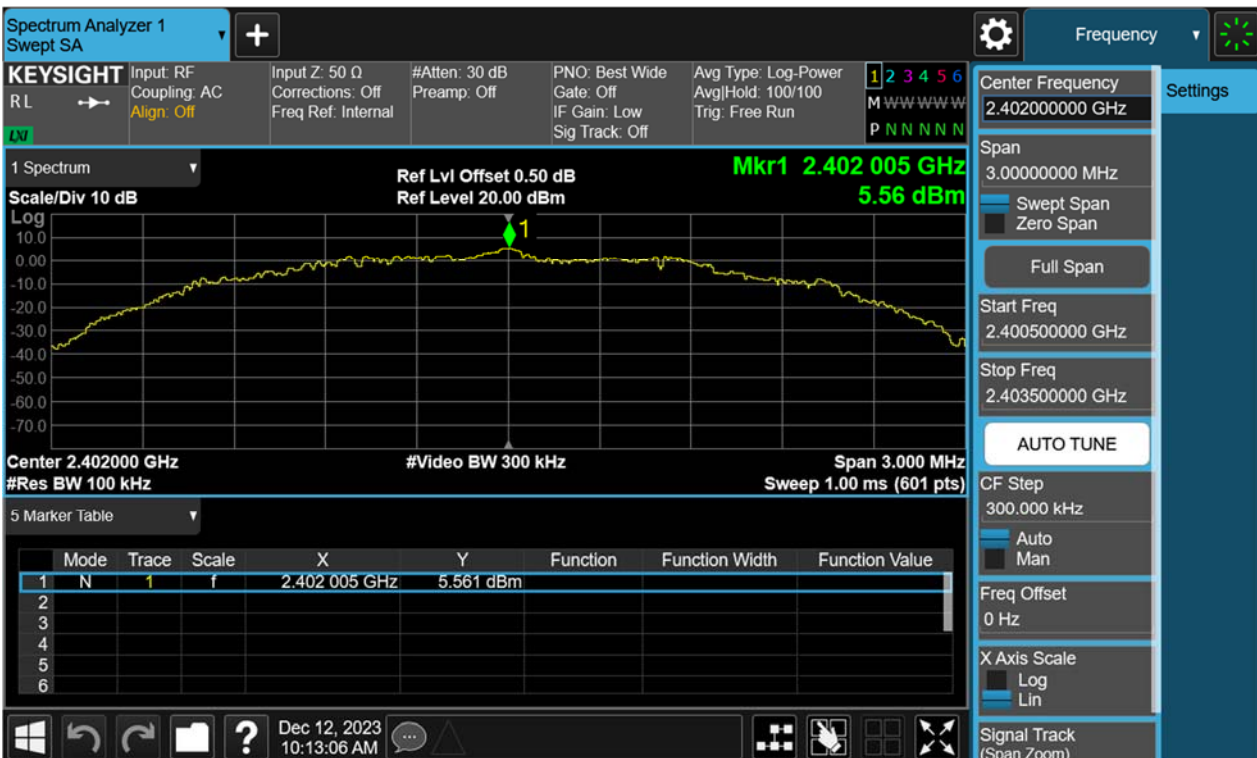

Figure 22: Conducted Spurious Emission & Authorized-band band-edge, 2402MHz, BLE-2Mbps Carrier Level



TEST REPORT

Report No.:

SHE23120009-02DE

Date:

2024-02-01

Page 35 of 59

Band Edge



Conducted spurious emissions 30MHz-25GHz

