



# NFC TEST REPORT

No.I19Z62229-IOT01

for

**TCL Communication Ltd.**

**HSUPA/HSDPA/UMTS 5 Bands/GSM Quad Bands/LTE 17 bands**

**mobile phone**

**T770B**

**FCC ID: 2ACCJN036**

with

**Hardware Version: 03**

**Software Version: 3C2G**

**Issued Date: 2019-02-17**

**Note:**

The test results in this test report relate only to the devices specified in this report. This report shall not be reproduced except in full without the written approval of CTTL.

The report must not be used by the client to claim product certification, approval, or endorsement by NVLAP, NIST, or any agency of the U.S. Government.

**Test Laboratory:**

**CTTL-Telecommunication Technology Labs, CAICT**

No. 52, Huayuan North Road, Haidian District, Beijing, P. R. China 100191.

Tel:+86(0)10-62304633-2512, Fax:+86(0)10-62304633-2504

Email: [ctl\\_terminals@caict.ac.cn](mailto:ctl_terminals@caict.ac.cn), website: [www.caict.ac.cn](http://www.caict.ac.cn)



## **REPORT HISTORY**

<b>Report Number</b>	<b>Revision</b>	<b>Description</b>	<b>Issue Date</b>
I19Z62229-IOT01	Rev.0	1st edition	2019-02-17

## **CONTENTS**

<b>1. TEST LABORATORY .....</b>	<b>4</b>
<b>1.1. INTRODUCTION &amp; ACCREDITATION.....</b>	<b>4</b>
<b>1.2. TESTING LOCATION .....</b>	<b>4</b>
<b>1.3. TESTING ENVIRONMENT .....</b>	<b>5</b>
<b>1.4. PROJECT DATA .....</b>	<b>5</b>
<b>1.5. SIGNATURE.....</b>	<b>5</b>
<b>2. CLIENT INFORMATION.....</b>	<b>6</b>
<b>2.1. APPLICANT INFORMATION.....</b>	<b>6</b>
<b>2.2. MANUFACTURER INFORMATION.....</b>	<b>6</b>
<b>3. EQUIPMENT UNDER TEST (EUT) AND ANCILLARY EQUIPMENT (AE) .....</b>	<b>7</b>
<b>3.1. ABOUT EUT .....</b>	<b>7</b>
<b>3.2. INTERNAL IDENTIFICATION OF EUT .....</b>	<b>7</b>
<b>3.3. INTERNAL IDENTIFICATION OF AE .....</b>	<b>7</b>
<b>3.4. EUT SET-UPS.....</b>	<b>8</b>
<b>4. REFERENCE DOCUMENTS .....</b>	<b>9</b>
<b>4.1. DOCUMENTS SUPPLIED BY APPLICANT .....</b>	<b>9</b>
<b>4.2. REFERENCE DOCUMENTS FOR TESTING .....</b>	<b>9</b>
<b>5. TEST RESULTS .....</b>	<b>10</b>
<b>5.1. SUMMARY OF TEST RESULTS .....</b>	<b>10</b>
<b>5.2. STATEMENTS.....</b>	<b>10</b>
<b>6. TEST FACILITIES UTILIZED .....</b>	<b>11</b>
<b>7. MEASUREMENT UNCERTAINTY .....</b>	<b>12</b>
<b>ANNEX A: EUT PARAMETERS.....</b>	<b>13</b>
<b>ANNEX B: DETAILED TEST RESULTS.....</b>	<b>14</b>
<b>ANNEX C: PERSONS INVOLVED IN THIS TESTING .....</b>	<b>26</b>
<b>ANNEX D: ACCREDITATION CERTIFICATE .....</b>	<b>27</b>



## **1. Test Laboratory**

### **1.1. Introduction & Accreditation**

**Telecommunication Technology Labs, CAICT** is an ISO/IEC 17025:2005 accredited test laboratory under NATIONAL VOLUNTARY LABORATORY ACCREDITATION PROGRAM (NVLAP) with lab code 600118-0, and is also an FCC accredited test laboratory (CN5017), and ISED accredited test laboratory (ISED#: 24849). The detail accreditation scope can be found on NVLAP website.

### **1.2. Testing Location**

Location 1: CTTL(huayuan North Road)

Address: No. 52, Huayuan North Road, Haidian District, Beijing,  
P. R. China 100191

Location 2: CTTL(Shouxiang)

Address: No. 51 Shouxiang Science Building, Xueyuan Road,  
Haidian District, Beijing, P. R. China 100191

### 1.3. Testing Environment

Normal Temperature: 15-35°C  
Extreme Temperature: -20/+50°C  
Normal Relative Humidity: 20-75%  
Normal Air Pressure 86Kpa-106Kpa

### 1.4. Project data

Testing Start Date: 2019-12-26  
Testing End Date: 2019-12-31

### 1.5. Signature



---

Zhang Qiang  
(Prepared this test report)



---

Pang Shuai  
(Reviewed this test report)



---

Zhu Liang  
(Approved this test report)



## **2. Client Information**

### **2.1. Applicant Information**

Company Name: TCL Communication Ltd.  
Address: 5/F, Building 22E, 22 Science Park East Avenue, Hong Kong Science  
Park, Shatin, NT, Hong Kong  
City: Hong Kong  
Postal Code: /  
Country: CHINA  
Telephone: 0086-755-36611722  
Fax: 0086-755-36612000-81722

### **2.2. Manufacturer Information**

Company Name: TCL Communication Ltd.  
Address: 5/F, Building 22E, 22 Science Park East Avenue, Hong Kong Science  
Park, Shatin, NT, Hong Kong  
City: Hong Kong  
Postal Code: /  
Country: CHINA  
Telephone: 0086-755-36611722  
Fax: 0086-755-36612000-81722

### **3. Equipment Under Test (EUT) and Ancillary Equipment (AE)**

#### **3.1. About EUT**

Description	HSUPA/HSDPA/UMTS 5 Bands/GSM Quad Bands/LTE 17 bands mobile phone
Model name/HVIN	T770B
Brand name	TCL
FCC ID	2ACCJN036
UMTS Frequency Band(s)	FDD I/II/IV/V/VIII
GSM Frequency Band(s)	GSM900/1800/1900/850
E-UTRA Frequency Band(s)	FDD1/2/3/4/5/7/8/12/13/17/25/26/28a/38/40/41/66
Extreme Temperature	-10/+55°C
Nominal Voltage	3.85V
Extreme High Voltage	4.4V
Extreme Low Voltage	3.6V

#### **3.2. Internal Identification of EUT**

<b>EUT ID*</b>	<b>SN or IMEI</b>	<b>HW Version</b>	<b>SW Version</b>	<b>Date of receipt</b>
14a	015658000201697	03	3C2G	2019-12-17
22a	015658000201457	03	3C2G	2019-12-17

\*EUT ID: is used to identify the test sample in the lab internally.

#### **3.3. Internal Identification of AE**

<b>AE ID*</b>	<b>Description</b>	<b>SN</b>
AE2	battery	/
AE3	Travel charger	/
AE4	USB Cable	/
AE5	USB Cable	/
AE13	NFC Card	/

##### **AE1**

Model	TLp038D1
Manufacturer	/
Capacitance	3860 mAh
Nominal voltage	3.85V

##### **AE3**

Model	UC13US
Manufacturer	PUAN
Length of cable	/

##### **AE4**

Model	CDA0000128C1
-------	--------------



Manufacturer	Juwei
Length of cable	/
AE5	
Model	CDA0000128C2
Manufacturer	Shenghua
Length of cable	/
AE13	
Model	/
Manufacturer	/
Length of cable	/

\*AE ID: is used to identify the ancillary equipment in the lab internally.

### 3.4. EUT Set-ups

**Table 1: Eut Set-ups**

EUT Set-up No.	Combination of EUT and AE	Remarks
Set. NFC01	EUT1 + AE1 + AE3 + AE4/AE5+ AE13	--
Set. NFC02	EUT1 + AE1 + AE13	--
Set. NFC03	14a	--

The Transmit State of NFC: the NFC function is on. The EUT will transmit the NFC data and command continuously during the test.

The Transmit state without modulation: The EUT will transmit the CW signal at the operating frequency.



## **4. Reference Documents**

### **4.1. Documents supplied by applicant**

EUT parameters, referring to Annex A for detailed information, are supplied by the client or manufacturer, which are the bases of testing.

### **4.2. Reference Documents for testing**

The following documents listed in this section are referred for testing.

<b>Reference</b>	<b>Title</b>	<b>Version</b>
CFR 47 Part 2	Part 2 — Frequency Allocations and Radio Treaty Matters; General Rules and Regulations.	2018
CFR 47 Part 15	Part 15 — Radio Frequency Devices. Subpart C — Intentional Radiators. § 15.35 Measurement detector functions and bandwidths. § 15.207 Conducted limits. § 15.209 Radiated emission limits, general requirements. § 15.215 Additional provisions to the general radiated emission limitations. § 15.225 Operation within the band 13.110–14.010 MHz.	2018
ANSI C63.10	American National Standard of Procedures for Compliance Testing of Unlicensed Wireless Devices	2013

## 5. Test Results

### 5.1. Summary of Test Results

**Table 2: Summary of Test Results**

No	Test Cases	Clause in Regulation	Section in This Report	Verdict
1	Electric Field Strength of Fundamental Emissions	CFR 47 § 15.225(a)	B.1	P(Set. NFC02)
2	Electric Field Strength of Outside the Allocated Bands	CFR 47 § 15.225(b) CFR 47 § 15.225(c)		P(Set. NFC02)
3	Electric Field Radiated Emissions	CFR 47 § 15.209	B.2	P(Set. NFC01)
		CFR 47 § 15.225(d)	B.3	P(Set. NFC01)
4	Frequency Tolerance	CFR 47 § 15.225(e)	B.4	P(Set. NFC03)
5	20dB Bandwidth	CFR 47 § 15.215(c)	B.5	P(Set. NFC03)
6	Conducted Emissions	CFR 47 § 15.207	B.6	P(Set. NFC01)

The measurement is carried out according to ANSI C63.10. See **ANNEX B** for details.

#### **Test Conditions:**

For this report, all the test cases listed above were tested under normal Temperature, Voltage, humidity and Air Pressure except the Frequency Tolerance test case. The specific conditions of Frequency Tolerance test case are listed in section B.4.3

**See Table 3 for terms for result verdict:**

**Table 3 Terms for result verdict**

P	Pass, The EUT complies with the essential requirements in the standard.
NP	Not Perform, The test was not performed by CTTL
NA	Not Applicable, The test was not applicable
F	Fail, The EUT does not comply with the essential requirements in the standard

### 5.2. Statements

The test cases listed in Section 5.1 of this report for the EUT specified in Section 3 were performed by CTTL according to the reference documents in Section 4.

The EUT meets all applicable requirements of the regulations and standards in Section 4.2.

## 6. Test Facilities Utilized

Table 4: Test Facilities Utilized

NO.	NAME	TYPE	SERIES NUMBER	PRODUCER	CAL. DUE DATE	CAL. INTERVAL
1.	Spectrum Analyzer	RSA3408A	B010277	Tektronix	2020-09-26	1 Year
2.	Climatic chamber	SH242	93008658	ESPEC	2020-02-27	1 Year
3.	Vector Signal Analyzer	FSQ40	200089	Rohde & Schwarz	2020-05-15	1 Year
4.	H-field Antenna	HFH2-Z2	829324/007	R&S	2020-12-03	1 Year
5.	Test Receiver	ESCI	100344	Rohde & Schwarz	2020-02-14	1 Year
6.	LISN	ENV216	101200	Rohde & Schwarz	2020-04-27	1 Year
7.	Test Receiver	ESU26	100235	Rohde & Schwarz	2020-03-01	1 Year
8.	BiLog Antenna	VULB9163	9163-1222	Schwarzbeck	2020-03-14	1 Year

## 7. Measurement Uncertainty

Table 5: Measurement Uncertainty

Item	Uncertainty
Frequency Tolerance	$U = 60.80 \text{ Hz}, k=1.96$
20dB Bandwidth	$U = 77 \text{ Hz}, k=2$
Radiated Emissions (<1GHz)	$U = 4.86 \text{ dB}, k=2$
Radiated Emissions (>1GHz)	$U = 5.26 \text{ dB}, k=2$
Conducted emission	$U = 3.38 \text{ dB}, k=2$



## **ANNEX A: EUT parameters**

/

## **ANNEX B: Detailed Test Results**

### **B.1. Electric Field Strength of Fundamental and Outside the Allocated bands**

#### **B.1.1. Reference**

See Clause 4, Clause 5 of ANSI C63.10-2013 generally.

#### **B.1.2. Measurement Methods**

The transmitter carrier output levels (E-Field) from the EUT are measured in a semi-anechoic chamber. The EUT is placed on a non-conductive stand of 80cm high, and at a measurement distance of 3m from the receiving antenna. The center of the receiving loop antenna is 1.0 meter above the ground. The E-field is measured with a shielded loop antenna connected to a measurement receiver. Detected E-field was maximized by rotating the EUT through 360° and adjusting the receiving antenna polarizations. The maximization processes were repeated with the EUT positioned respectively in its three orthogonal axes. The measurements were performed with the peak detector and if required, the quasi-peak detector.

The measurement bandwidth is:

**Table B-1: Measurement bandwidth**

Frequency of Emission (MHz)	RBW/VBW
12.56-14.56	10/30 kHz

The E-field measured at 3m is calculated as:

$$\text{E-field (dB}\mu\text{V/m)} = \text{Rx (dB}\mu\text{V)} + \text{Cable Loss (dB)} + \text{AF@3m (dB/m)}$$

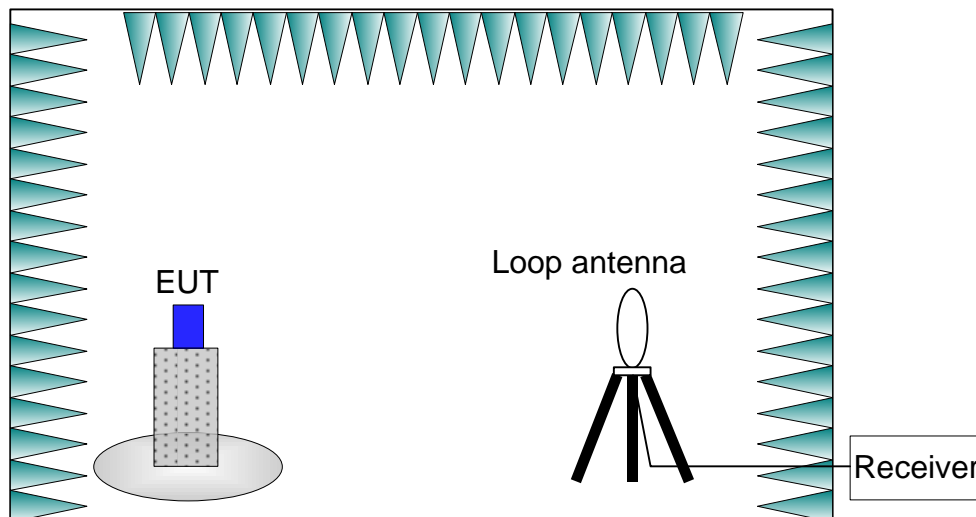

**Figure B-1: Measurement Setup**

#### **B.1.3. EUT Operating Mode and Test Conditions**

The measurement of EUT is carried out under the transmit state of NFC(See 3.4).

The EUT is powered by a travel adapter.

During the measurements, the ambient temperature of the electromagnetic anechoic chamber is in the range of 15 ~ 25 °C.

#### B.1.4. Limits

Table B-2: Limits

Frequency Range (MHz)	E-field Strength Limit @ 30 m (μV/m)	E-field Strength Limit @ 3 m (dBμV/m)
13.560 ± 0.007	+15,848	124
13.410 to 13.553 13.567 to 13.710	+334	90
13.110 to 13.410 13.710 to 14.010	+106	81

Note: Where the limits have been defined at one distance, and a signal level measured at another, the limits have been extrapolated using the following formula:

$$\text{Extrapolation(dB)} = 40\log_{10}(\text{Measurement Distance}/\text{Specification Distance})$$

#### B.1.5. Measurement Results

Measurement results of normal conditions see Figure B-2 for different set-ups of EUT. The results displayed take into account applicable antenna factors and cable losses.

**Conclusions:** Set.NFC02, **PASS**.

Full Spectrum

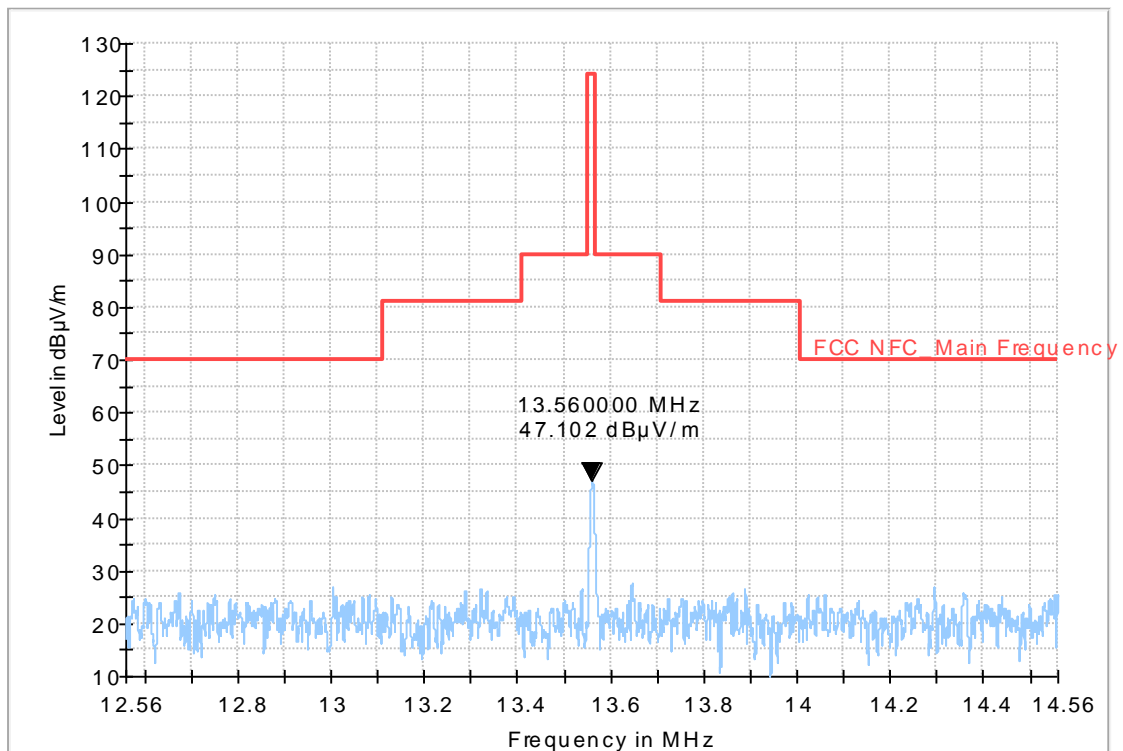

Figure B-2: Measurement results for Electric Field Strength of Fundamental and Outside the Allocated bands

## **B.2. Electric Field Radiated Emissions (< 30MHz)**

### **B.2.1. Reference**

See Clause 6.4 of ANSI C63.10-2013 specifically.

See Clause 4 and Clause 5 of ANSI C63.10-2013 generally.

### **B.2.2. Measurement Methods**

The transmitter carrier output levels (E-Field) from the EUT are measured in a semi-anechoic chamber. The EUT is placed on a non-conductive stand of 80cm high, and at a measurement distance of 3m from the receiving antenna. The center of the receiving loop antenna is 1.0 meter above the ground. The E-field is measured with a shielded loop antenna connected to a measurement receiver. Detected E-field was maximized by rotating the EUT through 360° and adjusting the receiving antenna polarizations. The maximization processes were repeated with the EUT positioned respectively in its three orthogonal axes. The measurements were performed with the peak detector and if required, the quasi-peak detector.

The measurement bandwidth is:

**Table B-3: Measurement bandwidth**

Frequency of Emission (MHz)	RBW/VBW
0.009-0.15	100/300 Hz
0.15-30	10/30 kHz

The E-field measured at 3m is calculated as:

$$\text{E-field (dB}\mu\text{V/m)} = \text{Rx (dB}\mu\text{V)} + \text{Cable Loss (dB)} + \text{AF@3m (dB/m)}$$

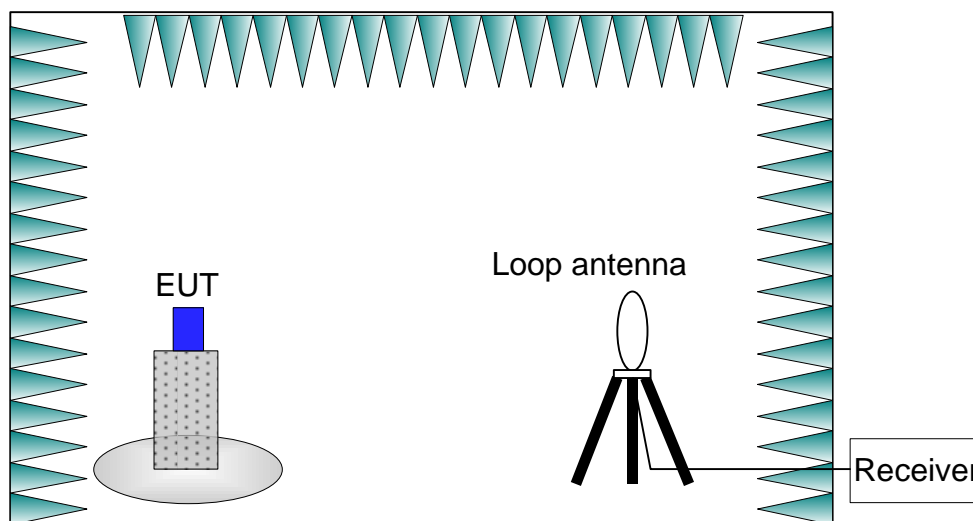

**Figure B-3: Measurement Setup**

### **B.2.3. EUT Operating Mode and Test Conditions**

The measurement of EUT is carried out under the transmit state of NFC(See 3.4).



The EUT is powered by a travel adapter.

During the measurements, the ambient temperature of the electromagnetic anechoic chamber is in the range of 15 ~ 25 °C.

#### B.2.4. Limits

Table B-4: Limits

Frequency Range (MHz)	E-field Strength Limit @ 30m (mV/m)	E-field Strength Limit @ 3m (dBµV/m)
0.009-0.490	2400/F(kHz)	129-94
0.490-1.705	24000/F(kHz)	74-63
1.705-30	30	70

Note: Where the limits have been defined at one distance, and a signal level measured at another, the limits have been extrapolated using the following formula:

$$\text{Extrapolation(dB)} = 40\log_{10}(\text{Measurement Distance}/\text{Specification Distance})$$

#### B.2.5. Measurement Results

Measurement results of normal conditions see Figure B-4 for different set-ups of EUT. The results displayed take into account applicable antenna factors and cable losses.

**Conclusions:** Set.NFC01, **PASS**.

Full Spectrum

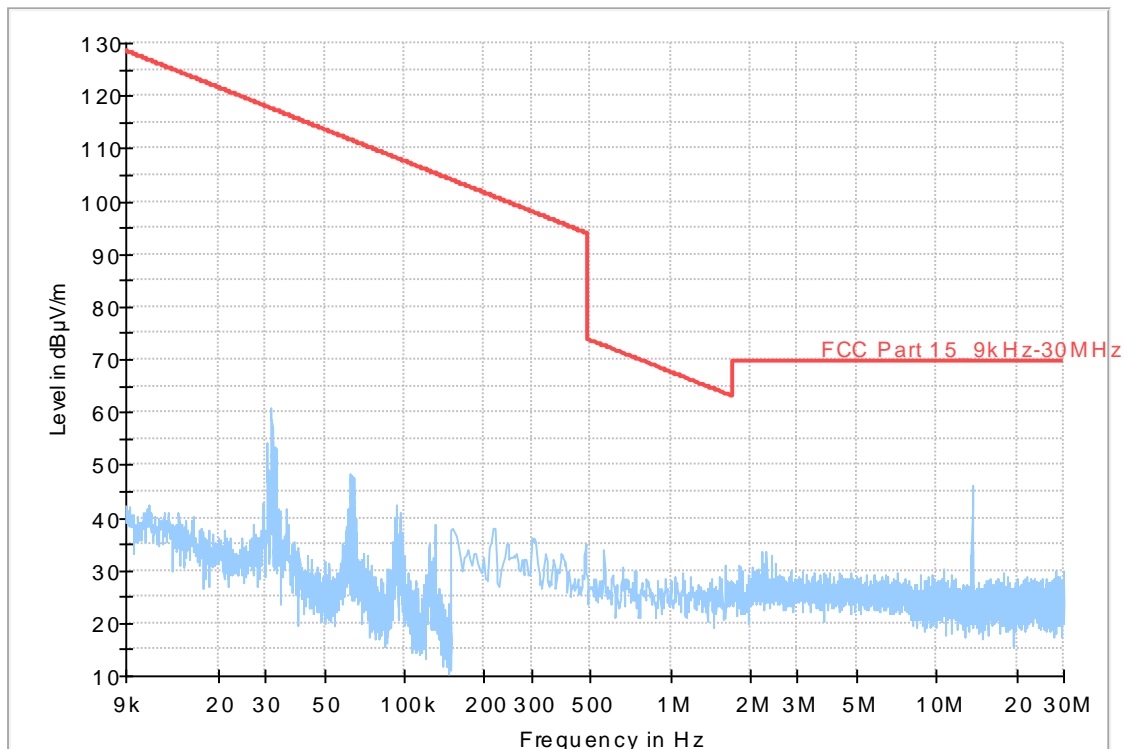

Figure B-4: Measurement results for Electric Field Radiated Emissions (< 30MHz)

### **B.3. Electric Field Radiated Emissions ( $\geq 30\text{MHz}$ )**

#### **B.3.1. Reference**

See Clause 6.5 of ANSI C63.10-2013 specifically.

See Clause 4 and Clause 5 of ANSI C63.10-2013 generally.

#### **B.3.2. Measurement Methods**

The electric field radiated emissions from the EUT are measured in a semi-anechoic chamber. The EUT is placed on a non-conductive stand of 80cm high, and at a measurement distance of 10m from the receiving antenna. The receiving antennas connected to a measurement receiver. In order to search for maximum field strength emitted from the EUT, the receiving antenna can be moved between the height of 1.0 m to 4.0 m. Detected E-field was maximized at each frequency by rotating the EUT through 360° and adjusting the receiving antenna positions for both vertical and horizontal antenna polarizations. The maximization processes were repeated with the EUT positioned respectively in its three orthogonal axes. The measurements were performed with the peak detector and if required, the quasi-peak detector.

The measurement bandwidth is:

**Table B-5: Measurement bandwidth**

Frequency of Emission (MHz)	RBW/VBW
30-1000	120kHz

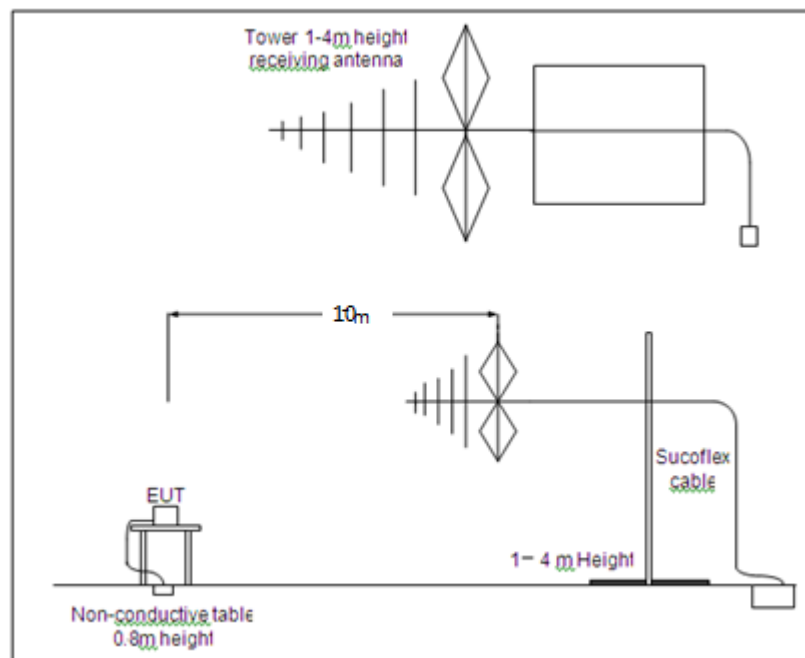

**Figure B-5: Measurement Setup**

#### **B.3.3. EUT Operating Mode and Test Conditions**

The measurement of EUT is carried out under the transmit state of NFC(See 3.4).

The EUT had been connected to a travel adapter.  
 During the measurements, the ambient temperature of the electromagnetic anechoic chamber is in the range of 15 ~ 25 °C.

### B.3.4. Limits

Table B-6: Limits

Frequency Range (MHz)	E-field Strength Limit @ 3m (mV/m)	E-field Strength Limit @ 3m (dBµV/m)	E-field Strength Limit @ 10m (dBµV/m)
30-88	100	40	30
88-216	150	43.5	33.5
216-960	200	46	36
960-1000	500	54	44

### B.3.5. Measurement Results

Measurement results of normal conditions see Figure B-6 for different set-ups of EUT. The results displayed take into account applicable antenna factors and cable losses.

**Conclusions:** Set.NFC01, **PASS**.

Full Spectrum

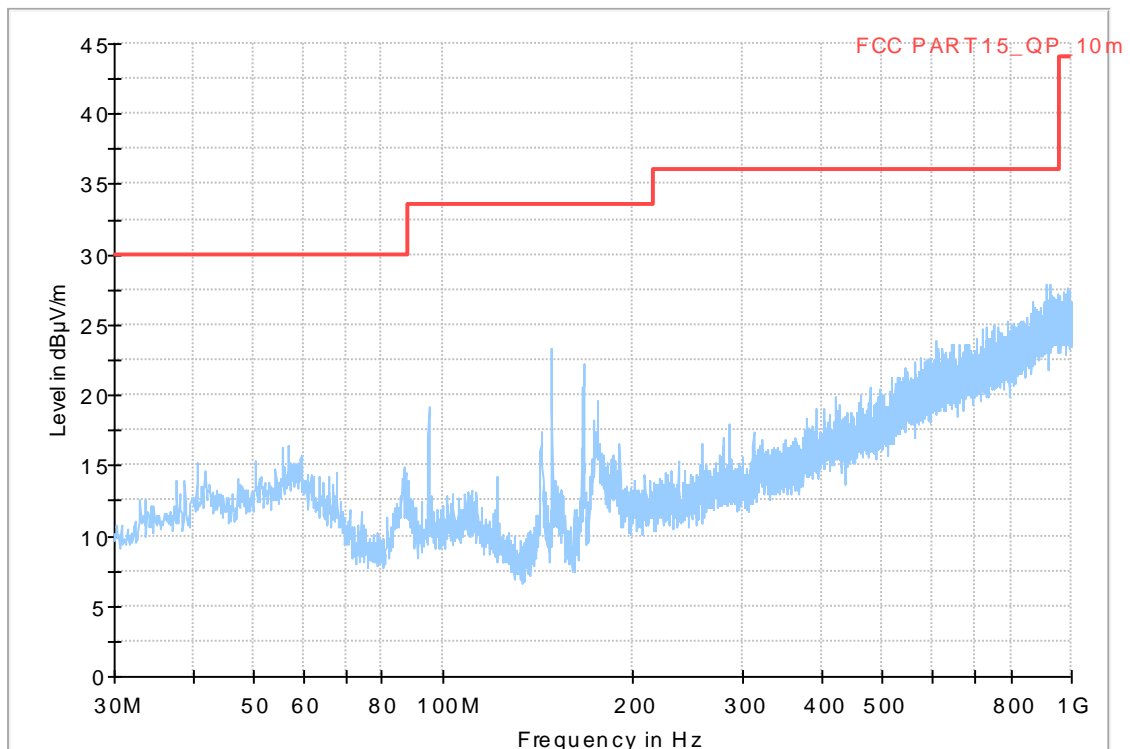

Figure B-6: Measurement results for Electric Field Radiated Emissions (≥30MHz)

## **B.4. Frequency Tolerance**

### **B.4.1. Reference**

See Clause 6.8 of ANSI C63.10-2013 specifically.

See Clause 4 and Clause 5 of ANSI C63.10-2013 generally.

### **B.4.2. Measurement Methods**

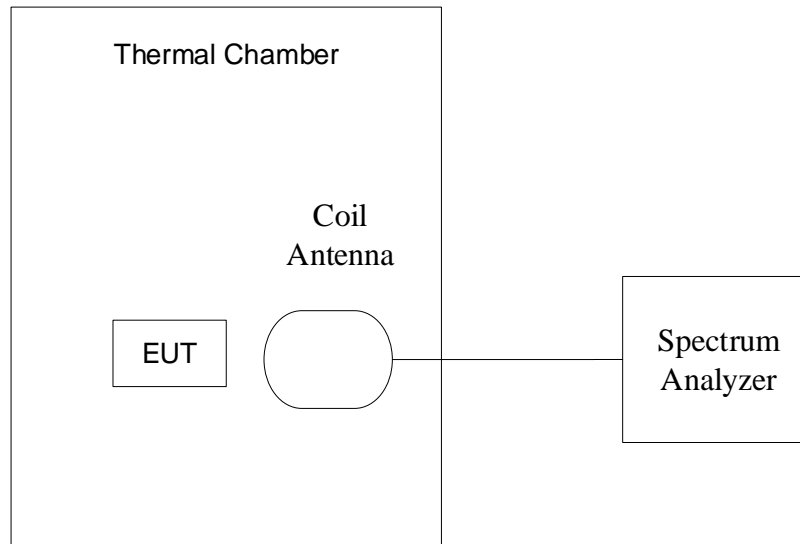

**Figure B-7: Measurement Setup**

The transmitter output signal was picked up by coil antenna connected to the spectrum analyzer. The center frequency was measured with 30Hz RBW and 1kHz span.

During the test, the EUT was placed in a thermal chamber until thermal balance and lasting appropriate time.

### **B.4.3. EUT Operating Mode and Test Conditions**

The measurement of EUT was carried out under the transmit state of without modulation(See 3.4). EUT had not been connected to a travel adapter. The frequency stability was measured with the different voltage and temperature combinations:

- a) The nominal voltage 3.85V(See 3.1)was used and the temperature was varied from -20°C to +50°C in 10°C increments using an environmental chamber.
- b) The 20°C was used and the voltages were 3.6V, 3.85V and 4.4V (The extreme low voltage ,the nominal voltage and the extreme high voltage defined in section 3.1).

The details were as following:

**Table B-7: Combinations of Voltage andTemperature**

Test items	Voltage	Temperature
Frequency stability with respect to ambient temperature	3.85V	-20°C
		-10°C
		0°C
		10°C

		20°C
		30°C
		40°C
		50°C
Frequency stability when varying supply voltage	3.6V	20°C
	3.85V	
	4.4V	

#### B.4.4. Test Layouts

See B.4.2.

#### B.4.5. Limits

The frequency tolerance of the carrier signal shall be maintained within +/- 0.01% of the operating frequency.

#### B.4.6. Measurement Results

Measurement results see Table B-9 for different test conditions.

**Conclusions:** Set.NFC03, **PASS**.

**Table B-8: Measurement results for Frequency Tolerance**

Temperature	Voltage	Frequency (MHz)			
		Startup	2 Min Later	5 Min Later	10 Min Later
-20°C	3.85V	13.56000962	13.56001122	13.56001923	13.56001442
-10°C	3.85V	13.56003532	13.56003686	13.56003846	13.56004006
0°C	3.85V	13.56004327	13.56007212	13.56004006	13.56004327
10°C	3.85V	13.56002724	13.56002244	13.56002404	13.56002564
20°C	3.85V	13.56000641	13.5600016	13.5599984	13.55999679
30°C	3.85V	13.55996795	13.55996955	13.55996474	13.55996875
40°C	3.85V	13.55994017	13.55993814	13.55993846	13.55993942
50°C	3.85V	13.55992308	13.55992115	13.55992019	13.55992147
20°C	3.6V	13.5599984	13.55999679	13.5600016	13.55999519
20°C	3.85V	13.56000641	13.5600016	13.5599984	13.55999679
20°C	4.4V	13.55999359	13.55999038	13.55998878	13.55998958

Temperature	Voltage	Frequency Error (%)			
		Startup	2 Min Later	5 Min Later	10 Min Later
-20°C	3.85V	0.000	0.000	0.000	0.000
-10°C	3.85V	0.000	0.000	0.000	0.000
0°C	3.85V	0.000	0.001	0.000	0.000
10°C	3.85V	0.000	0.000	0.000	0.000
20°C	3.85V	0.000	0.000	0.000	0.000
30°C	3.85V	0.000	0.000	0.000	0.000
40°C	3.85V	0.000	0.000	0.000	0.000

50°C	3.85V	-0.001	-0.001	-0.001	-0.001
20°C	3.6V	0.000	0.000	0.000	0.000
20°C	3.85V	0.000	0.000	0.000	0.000
20°C	4.4V	0.000	0.000	0.000	0.000

#### B.4.7. Measurement Uncertainty

Measurement uncertainty:  $U = 60.80 \text{ Hz}$ ,  $k=1.96$

### B.5. 20dB Bandwidth

#### B.5.1. Reference

See Clause 6.9 of ANSI C63.10-2013 specifically.

See Clause 4 and Clause 5 of ANSI C63.10-2013 generally.

#### B.5.2. Measurement Methods

The transmitter output signal was picked up by coil antenna connected to the spectrum analyzer. The bandwidth of the center frequency was measured with 140Hz RBW, 420Hz VBW and 14kHz span.

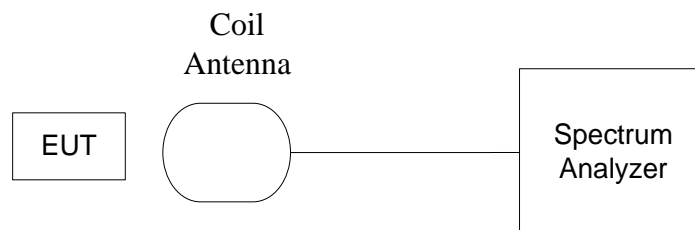

**Figure B-8: Measurement Setup**

#### B.5.3. EUT Operating Mode and Test Conditions

The measurement of EUT was carried out under the transmit state of NFC (See 3.4). EUT had not been connected to a travel adapter.

During the measurements, the ambient temperature was in the range of 15 ~ 25 °C.

#### B.5.4. Test Layouts

See B.5.2.

#### B.5.5. Limits

The 20dB bandwidth shall be less than 80% of the permitted frequency band. For 13.56 MHz NFC, the permitted frequency band is 14kHz, so the limit is 11.2 kHz.

#### B.5.6. Measurement Results

Measurement results see Figure B-9.

**Conclusions:** Set.NFC03, **PASS**.



Frequency of Emission (MHz)	RBW/VBW
0.15-30	9kHz

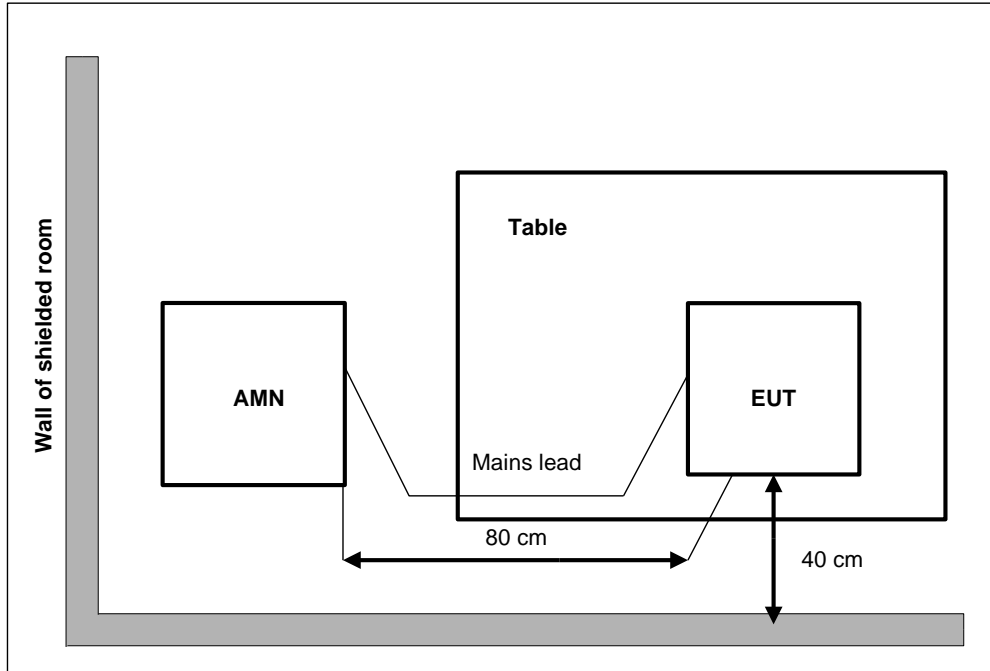

**Figure B-10: Measurement Setup**

### B.6.3. EUT Operating Mode and Test Conditions

The measurement of EUT is carried out under the transmit state of NFC(See 3.4).

The EUT is powered by a travel adapter.

During the measurements, the ambient temperature is in the range of 15 ~ 25 °C.

### B.6.4. Limits

**Table B-10: Limits**

Frequency range (MHz)	Quasi-peak Limit (dB $\mu$ V)	Average Limit (dB $\mu$ V)
0.15 to 0.5	66 to 56	56 to 46
0.5 to 5	56	46
5 to 30	60	50

### B.6.5. Measurement Results

Measurement results see Figure B-11.

**Conclusions:** Set.NFC01, **PASS**.



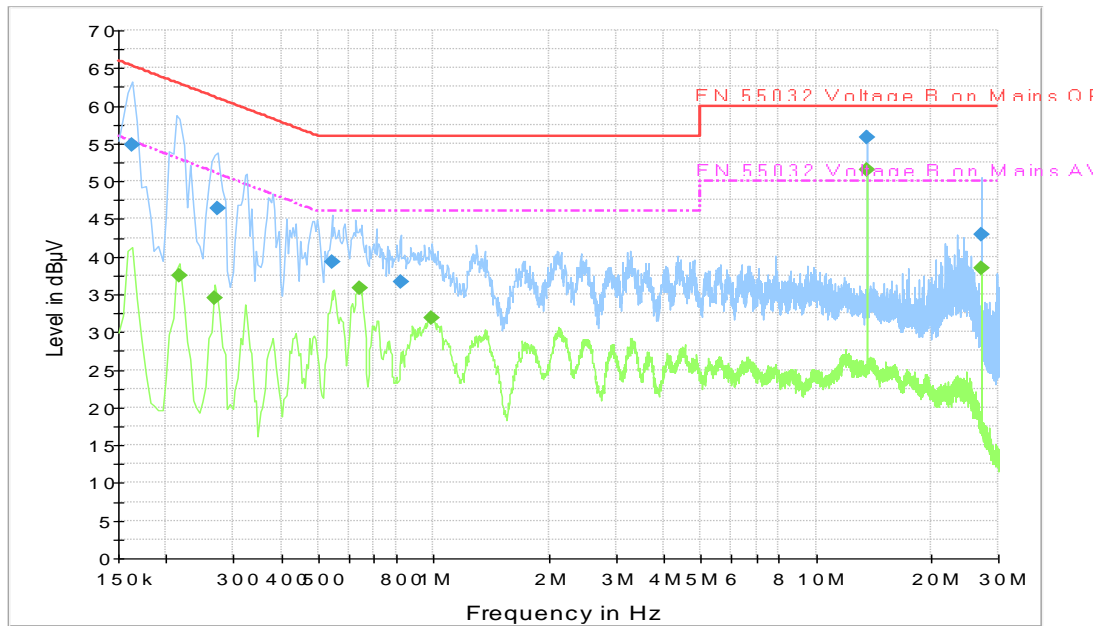

Note: the spike over the limit is the NFC carrier frequency and coming from the radio equipment.

**Figure B-11: Measurement results for Conducted Emission**

**Final Result 1**

**Table B-11: Final Result 1**

Frequency (MHz)	QuasiPeak (dBµV)	Line	Margin (dB)	Limit (dBµV)
0.163500	54.8	L1	10.5	65.3
0.271500	46.4	L1	14.7	61.1
0.541500	39.4	L1	16.6	56.0
0.820500	36.7	N	19.3	56.0
27.118500	42.8	L1	17.2	60.0

**Final Result 2**

**Table B-12: Final Result 2**

Frequency (MHz)	Average (dBµV)	Line	Margin (dB)	Limit (dBµV)
0.217500	37.5	N	15.4	52.9
0.267000	34.4	N	16.8	51.2
0.640500	35.8	N	10.2	46.0
0.991500	31.8	N	14.2	46.0
27.118500	38.4	L1	11.6	50.0

## **ANNEX C: Persons involved in this testing**

**Table C-1: Persons involved**

<b>Test Item</b>	<b>Tester</b>
20dB Bandwidth	Zhou Bin
Frequency Tolerance	Zhou Bin
Electric Field Strength of Fundamental and Outside the Allocated bands	Li Pengfei
Electric Field Radiated Emissions (< 30MHz)	Li Pengfei
Electric Field Radiated Emissions ( $\geq 30$ MHz)	Li Pengfei
Conducted Emissions	Yan Hanchen

## ANNEX D: Accreditation Certificate

<p>United States Department of Commerce National Institute of Standards and Technology</p>  <hr/> <p><b>Certificate of Accreditation to ISO/IEC 17025:2005</b></p> <hr/> <p>NVLAP LAB CODE: 600118-0</p> <p><b>Telecommunication Technology Labs, CAICT</b> Beijing China</p> <p><i>is accredited by the National Voluntary Laboratory Accreditation Program for specific services, listed on the Scope of Accreditation, for:</i></p> <p><b>Electromagnetic Compatibility &amp; Telecommunications</b></p> <p><i>This laboratory is accredited in accordance with the recognized International Standard ISO/IEC 17025:2005. This accreditation demonstrates technical competence for a defined scope and the operation of a laboratory quality management system (refer to joint ISO-ILAC-IAF Communiqué dated January 2009).</i></p> <hr/> <table border="0" style="width: 100%;"><tr><td style="width: 40%; text-align: center;"><p>2019-09-26 through 2020-09-30 <i>Effective Dates</i></p></td><td style="width: 20%; text-align: center;"></td><td style="width: 40%; text-align: center;"> <i>For the National Voluntary Laboratory Accreditation Program</i></td></tr></table>		<p>2019-09-26 through 2020-09-30 <i>Effective Dates</i></p>		 <i>For the National Voluntary Laboratory Accreditation Program</i>
<p>2019-09-26 through 2020-09-30 <i>Effective Dates</i></p>		 <i>For the National Voluntary Laboratory Accreditation Program</i>		

\*\*\*END OF REPORT\*\*\*