

## 802.11n-HT20

## Channel 36

Frequency (MHz)	Measurement Result (dB $\mu$ V/m)	Cable loss (dB)	Antenna Factor (dB/m)	Receiver Reading (dB $\mu$ V)	Limit (dB $\mu$ V/m)	Margin (dB)	Antenna Pol. (H/V)	Antenna Height (cm)	Turntable angle (deg)
5148.175	64.6	-34.8	34.2	65.17	74.0	9.4	H	155	22
5148.880	64.7	-34.8	34.2	65.27	74.0	9.3	H	155	44
10359.950	50.2	-30.0	37.5	42.70	74.0	23.8	V	155	0
15539.850	51.2	-27.6	40.1	38.73	74.0	22.8	H	155	0
16411.600	55.0	-27.1	41.2	40.88	74.0	19.0	V	155	22
16887.350	55.6	-27.0	41.6	40.92	74.0	18.4	H	155	176

## Channel 40

Frequency (MHz)	Measurement Result (dB $\mu$ V/m)	Cable loss (dB)	Antenna Factor (dB/m)	Receiver Reading (dB $\mu$ V)	Limit (dB $\mu$ V/m)	Margin (dB)	Antenna Pol. (H/V)	Antenna Height (cm)	Turntable angle (deg)
5107.000	49.5	-35.0	34.2	50.33	74.0	24.5	H	155	88
5256.800	48.2	-34.7	34.3	48.56	74.0	25.8	H	155	22
10400.100	48.5	-29.4	37.5	40.39	74.0	25.5	V	155	220
15599.800	51.3	-27.5	40.2	38.60	74.0	22.7	V	155	242
16492.450	54.3	-27.0	41.3	40.04	74.0	19.7	V	155	44
16989.100	55.1	-26.8	41.7	40.22	74.0	18.9	V	155	66

## Channel 48

Frequency (MHz)	Measurement Result (dB $\mu$ V/m)	Cable loss (dB)	Antenna Factor (dB/m)	Receiver Reading (dB $\mu$ V)	Limit (dB $\mu$ V/m)	Margin (dB)	Antenna Pol. (H/V)	Antenna Height (cm)	Turntable angle (deg)
5160.400	50.2	-34.6	34.2	50.56	74.0	23.8	H	155	0
5301.800	49.9	-35.1	34.3	50.64	74.0	24.1	H	155	22
10479.850	48.9	-31.5	37.6	42.77	74.0	25.1	H	155	110
15720.250	51.0	-27.5	40.4	38.11	74.0	23.0	V	155	132
16413.250	54.0	-27.1	41.2	39.90	74.0	20.0	V	155	66
16772.400	55.6	-26.7	41.5	40.82	74.0	18.4	V	155	88

## Channel 52

Frequency (MHz)	Measurement Result (dB $\mu$ V/m)	Cable loss (dB)	Antenna Factor (dB/m)	Receiver Reading (dB $\mu$ V)	Limit (dB $\mu$ V/m)	Margin (dB)	Antenna Pol. (H/V)	Antenna Height (cm)	Turntable angle (deg)
5217.800	56.4	-34.3	34.3	56.48	68.3	11.9	H	155	22
5295.600	56.3	-35.1	34.3	57.12	68.3	12.0	H	155	44
10520.000	47.5	-32.0	37.6	41.92	68.3	20.8	V	155	0
15780.200	50.2	-27.6	40.4	37.36	68.3	18.1	H	155	0
16562.300	54.1	-26.7	41.4	39.51	68.3	14.2	V	155	22
17093.050	56.1	-26.1	41.6	40.60	68.3	12.2	H	155	176

## Channel 56

Frequency (MHz)	Measurement Result (dB $\mu$ V/m)	Cable loss (dB)	Antenna Factor (dB/m)	Receiver Reading (dB $\mu$ V)	Limit (dB $\mu$ V/m)	Margin (dB)	Antenna Pol. (H/V)	Antenna Height (cm)	Turntable angle (deg)
5241.600	58.3	-34.5	34.3	58.47	68.3	10.0	H	155	22
5315.400	57.9	-35.0	34.4	58.53	68.3	10.4	H	155	242
10560.150	47.4	-30.6	37.6	40.39	68.3	20.9	V	155	44
15840.150	50.2	-27.5	40.5	37.23	68.3	18.1	H	155	88
16658.000	54.2	-26.6	41.4	39.37	68.3	14.1	V	155	176
17028.150	54.4	-26.5	41.7	39.27	68.3	13.9	H	155	0

## Channel 64

Frequency (MHz)	Measurement Result (dB $\mu$ V/m)	Cable loss (dB)	Antenna Factor (dB/m)	Receiver Reading (dB $\mu$ V)	Limit (dB $\mu$ V/m)	Margin (dB)	Antenna Pol. (H/V)	Antenna Height (cm)	Turntable angle (deg)
5350.350	56.7	-34.6	34.4	56.88	68.3	11.6	H	155	22
5351.555	56.1	-34.5	34.4	56.27	68.3	12.2	H	155	22
10639.900	46.3	-29.0	37.7	37.64	68.3	22.0	H	155	88
15960.050	50.6	-27.1	40.7	37.02	68.3	17.7	V	155	110
16722.350	55.4	-26.7	41.5	40.59	68.3	12.9	V	155	44
17084.250	55.3	-26.2	41.6	39.88	68.3	13.0	H	155	0

## Channel 100

Frequency (MHz)	Measurement Result (dB $\mu$ V/m)	Cable loss (dB)	Antenna Factor (dB/m)	Receiver Reading (dB $\mu$ V)	Limit (dB $\mu$ V/m)	Margin (dB)	Antenna Pol. (H/V)	Antenna Height (cm)	Turntable angle (deg)
5458.300	58.2	-33.2	34.5	56.97	74.0	15.8	H	155	22
5459.365	57.9	-33.2	34.5	56.64	74.0	16.1	V	155	242
11000.150	49.1	-30.1	37.8	41.40	74.0	24.9	H	155	44
16500.150	52.3	-27.0	41.3	38.00	74.0	21.7	V	155	88
16965.450	56.0	-26.9	41.7	41.28	74.0	18.0	V	155	176
17062.800	55.2	-26.3	41.6	39.88	74.0	18.8	V	155	0

## Channel 120

Frequency (MHz)	Measurement Result (dB $\mu$ V/m)	Cable loss (dB)	Antenna Factor (dB/m)	Receiver Reading (dB $\mu$ V)	Limit (dB $\mu$ V/m)	Margin (dB)	Antenna Pol. (H/V)	Antenna Height (cm)	Turntable angle (deg)
5554.200	53.9	-34.7	34.6	54.04	74.0	20.1	H	155	0
5635.800	54.1	-33.4	34.7	52.79	74.0	19.9	V	155	22
11199.800	48.9	-30.3	38.0	41.25	74.0	25.1	V	155	352
16799.900	52.3	-26.8	41.5	37.60	74.0	21.7	V	155	352
16955.550	55.7	-27.0	41.7	40.99	74.0	18.3	V	155	176
17084.800	55.4	-26.2	41.6	39.95	74.0	18.6	V	155	110

## Channel 140

Frequency (MHz)	Measurement Result (dB $\mu$ V/m)	Cable loss (dB)	Antenna Factor (dB/m)	Receiver Reading (dB $\mu$ V)	Limit (dB $\mu$ V/m)	Margin (dB)	Antenna Pol. (H/V)	Antenna Height (cm)	Turntable angle (deg)
5725.995	60.2	-33.6	34.8	58.96	74.0	13.8	V	155	0
5726.470	60.4	-33.6	34.8	59.22	74.0	13.6	V	155	22
11400.000	49.9	-30.4	38.1	42.14	74.0	24.1	H	155	0
17100.200	53.5	-26.1	41.6	37.97	74.0	20.5	H	155	264
17397.200	55.0	-26.5	41.3	40.22	74.0	19.0	H	155	110
17498.400	56.4	-26.3	41.2	41.55	74.0	17.6	H	155	242

**802.11n-HT40**

## Channel 38

Frequency (MHz)	Measurement Result (dBμV/m)	Cable loss (dB)	Antenna Factor (dB/m)	Receiver Reading (dBμV)	Limit (dBμV/m)	Margin (dB)	Antenna Pol. (H/V)	Antenna Height (cm)	Turntable angle (deg)
5136.130	58.0	-35.0	34.2	58.71	74.0	16.0	H	155	22
5144.435	58.2	-34.8	34.2	58.79	74.0	15.8	H	155	44
10379.750	47.2	-29.7	37.5	39.39	74.0	26.8	H	155	88
15570.100	50.6	-27.6	40.2	37.96	74.0	23.4	V	155	110
16290.050	54.3	-26.6	41.1	39.81	74.0	19.7	V	155	110
17036.950	55.6	-26.5	41.7	40.45	74.0	18.4	V	155	88

## Channel 46

Frequency (MHz)	Measurement Result (dBμV/m)	Cable loss (dB)	Antenna Factor (dB/m)	Receiver Reading (dBμV)	Limit (dBμV/m)	Margin (dB)	Antenna Pol. (H/V)	Antenna Height (cm)	Turntable angle (deg)
5167.000	47.0	-34.5	34.2	47.25	74.0	27.0	H	155	88
5307.000	48.3	-35.0	34.4	48.94	74.0	25.7	H	155	132
10460.050	47.0	-30.9	37.6	40.36	74.0	27.0	H	155	0
15690.000	50.4	-27.4	40.3	37.56	74.0	23.6	V	155	66
16345.050	53.6	-26.8	41.1	39.31	74.0	20.4	V	155	44
17082.600	55.8	-26.2	41.6	40.38	74.0	18.2	H	155	242

## Channel 54

Frequency (MHz)	Measurement Result (dBμV/m)	Cable loss (dB)	Antenna Factor (dB/m)	Receiver Reading (dBμV)	Limit (dBμV/m)	Margin (dB)	Antenna Pol. (H/V)	Antenna Height (cm)	Turntable angle (deg)
5206.400	57.9	-34.3	34.3	57.93	68.3	10.4	H	155	22
5322.000	58.0	-34.9	34.4	58.57	68.3	10.3	H	155	44
10539.800	47.6	-31.3	37.6	41.27	68.3	20.7	V	155	242
15809.900	51.0	-27.6	40.5	38.20	68.3	17.3	H	155	176
16591.450	55.3	-26.6	41.4	40.56	68.3	13.0	V	155	88
16985.800	55.0	-26.8	41.7	40.10	68.3	13.3	V	155	22

## Channel 62

Frequency (MHz)	Measurement Result (dB $\mu$ V/m)	Cable loss (dB)	Antenna Factor (dB/m)	Receiver Reading (dB $\mu$ V)	Limit (dB $\mu$ V/m)	Margin (dB)	Antenna Pol. (H/V)	Antenna Height (cm)	Turntable angle (deg)
5350.685	62.0	-34.6	34.4	62.13	68.3	6.3	H	155	88
5354.235	61.2	-34.5	34.4	61.25	68.3	7.1	H	155	132
10620.100	46.3	-28.8	37.6	37.48	68.3	22.0	H	155	0
15929.800	51.4	-27.2	40.6	37.97	68.3	16.9	V	155	66
16707.700	56.0	-26.7	41.5	41.23	68.3	12.3	V	155	44
17313.050	55.9	-26.8	41.4	41.32	68.3	12.4	H	155	242

## Channel 102

Frequency (MHz)	Measurement Result (dB $\mu$ V/m)	Cable loss (dB)	Antenna Factor (dB/m)	Receiver Reading (dB $\mu$ V)	Limit (dB $\mu$ V/m)	Margin (dB)	Antenna Pol. (H/V)	Antenna Height (cm)	Turntable angle (deg)
5459.550	59.5	-33.2	34.5	58.31	74.0	14.5	H	155	22
5456.275	59.3	-33.2	34.5	58.01	74.0	14.7	H	155	66
11020.000	48.2	-30.7	37.8	41.05	74.0	25.8	V	155	132
16530.000	53.8	-26.9	41.3	39.36	74.0	20.2	H	155	0
17295.450	55.0	-26.8	41.4	40.45	74.0	19.0	V	155	88
17952.760	55.0	-26.0	41.3	39.66	74.0	19.0	V	155	242

## Channel 118

Frequency (MHz)	Measurement Result (dB $\mu$ V/m)	Cable loss (dB)	Antenna Factor (dB/m)	Receiver Reading (dB $\mu$ V)	Limit (dB $\mu$ V/m)	Margin (dB)	Antenna Pol. (H/V)	Antenna Height (cm)	Turntable angle (deg)
5536.200	56.5	-34.5	34.6	56.44	74.0	17.5	H	155	264
5642.200	56.6	-33.2	34.7	55.12	74.0	17.4	H	155	286
11180.000	47.0	-30.1	37.9	39.21	74.0	27.0	V	155	22
16770.000	54.0	-26.7	41.5	39.25	74.0	20.0	V	155	176
17106.860	55.0	-26.0	41.6	39.46	74.0	19.0	H	155	198
17672.580	55.2	-26.5	41.2	40.46	74.0	18.8	H	155	0

**Channel 134**

Frequency (MHz)	Measurement Result (dBμV/m)	Cable loss (dB)	Antenna Factor (dB/m)	Receiver Reading (dBμV)	Limit (dBμV/m)	Margin (dB)	Antenna Pol. (H/V)	Antenna Height (cm)	Turntable angle (deg)
5732.560	58.7	-33.7	34.8	57.61	74.0	15.3	H	155	22
5741.280	57.7	-33.9	34.8	56.70	74.0	16.3	V	155	44
11340.000	48.2	-30.5	38.1	40.62	74.0	25.8	H	155	0
17010.000	54.4	-26.6	41.7	39.34	74.0	19.6	H	155	0
17142.560	54.8	-26.1	41.6	39.33	74.0	19.2	H	155	22
17976.950	54.6	-25.9	41.3	39.16	74.0	19.4	H	155	176

**802.11ac-HT20**
**Channel 36**

Frequency (MHz)	Measurement Result (dBμV/m)	Cable loss (dB)	Antenna Factor (dB/m)	Receiver Reading (dBμV)	Limit (dBμV/m)	Margin (dB)	Antenna Pol. (H/V)	Antenna Height (cm)	Turntable angle (deg)
5148.340	64.7	-34.8	34.2	65.30	74.0	9.3	H	155	0
5148.815	64.8	-34.8	34.2	65.34	74.0	9.2	H	155	22
10359.950	50.5	-30.0	37.5	42.94	74.0	23.5	V	155	308
15539.850	50.9	-27.6	40.1	38.42	74.0	23.1	H	155	44
16841.150	54.8	-26.9	41.6	40.06	74.0	19.2	V	155	66
17243.750	54.9	-26.6	41.5	40.05	74.0	19.1	H	155	88

**Channel 40**

Frequency (MHz)	Measurement Result (dBμV/m)	Cable loss (dB)	Antenna Factor (dB/m)	Receiver Reading (dBμV)	Limit (dBμV/m)	Margin (dB)	Antenna Pol. (H/V)	Antenna Height (cm)	Turntable angle (deg)
5107.000	49.3	-35.0	34.2	50.17	74.0	24.7	H	155	264
5275.600	48.4	-35.0	34.3	49.02	74.0	25.6	H	155	132
10400.100	49.2	-29.4	37.5	41.14	74.0	24.8	H	155	110
15599.800	50.3	-27.5	40.2	37.52	74.0	23.7	H	155	44
16801.000	55.5	-26.8	41.5	40.75	74.0	18.5	H	155	22
17189.850	55.4	-26.4	41.5	40.21	74.0	18.6	V	155	0

**Channel 48**

Frequency (MHz)	Measurement Result (dB $\mu$ V/m)	Cable loss (dB)	Antenna Factor (dB/m)	Receiver Reading (dB $\mu$ V)	Limit (dB $\mu$ V/m)	Margin (dB)	Antenna Pol. (H/V)	Antenna Height (cm)	Turntable angle (deg)
5154.200	47.7	-34.7	34.2	48.20	74.0	26.3	H	155	0
5322.600	49.2	-34.9	34.4	49.74	74.0	24.8	H	155	22
10479.850	49.6	-31.5	37.6	43.47	74.0	24.4	V	155	352
15720.250	51.5	-27.5	40.4	38.61	74.0	22.5	V	155	352
16545.250	54.5	-26.8	41.3	39.99	74.0	19.5	V	155	176
17111.750	55.9	-26.0	41.6	40.29	74.0	18.1	V	155	176

## Channel 52

Frequency (MHz)	Measurement Result (dB $\mu$ V/m)	Cable loss (dB)	Antenna Factor (dB/m)	Receiver Reading (dB $\mu$ V)	Limit (dB $\mu$ V/m)	Margin (dB)	Antenna Pol. (H/V)	Antenna Height (cm)	Turntable angle (deg)
5228.400	59.9	-34.4	34.3	59.95	68.3	8.4	H	155	44
5288.200	59.6	-35.1	34.3	60.42	68.3	8.7	H	155	0
10520.000	49.3	-32.0	37.6	43.68	68.3	19.0	V	155	308
15780.200	50.9	-27.6	40.4	38.02	68.3	17.5	H	155	44
16259.250	53.8	-26.7	41.0	39.50	68.3	14.5	V	155	66
16882.400	54.8	-26.9	41.6	40.10	68.3	13.5	H	155	88

## Channel 56

Frequency (MHz)	Measurement Result (dB $\mu$ V/m)	Cable loss (dB)	Antenna Factor (dB/m)	Receiver Reading (dB $\mu$ V)	Limit (dB $\mu$ V/m)	Margin (dB)	Antenna Pol. (H/V)	Antenna Height (cm)	Turntable angle (deg)
5247.600	59.8	-34.6	34.3	60.07	68.3	8.5	H	155	22
5306.800	61.4	-35.0	34.3	62.10	68.3	6.9	H	155	44
10560.150	47.1	-30.6	37.6	40.12	68.3	21.2	V	155	220
15840.150	51.6	-27.5	40.5	38.59	68.3	16.7	V	155	242
16521.600	54.3	-26.9	41.3	39.86	68.3	14.0	H	155	264
16963.250	55.3	-26.9	41.7	40.53	68.3	13.0	H	155	286

## Channel 64

Frequency (MHz)	Measurement Result (dB $\mu$ V/m)	Cable loss (dB)	Antenna Factor (dB/m)	Receiver Reading (dB $\mu$ V)	Limit (dB $\mu$ V/m)	Margin (dB)	Antenna Pol. (H/V)	Antenna Height (cm)	Turntable angle (deg)
5350.915	59.3	-34.6	34.4	59.44	68.3	9.0	H	155	22
5351.565	58.9	-34.5	34.4	59.10	68.3	9.4	H	155	44
10639.900	47.1	-29.0	37.7	38.46	68.3	21.2	V	155	0
15960.050	51.6	-27.1	40.7	38.04	68.3	16.7	H	155	22
16356.600	54.9	-26.9	41.1	40.63	68.3	13.4	H	155	242
16779.550	54.7	-26.8	41.5	39.88	68.3	13.7	H	155	88

## Channel 100

Frequency (MHz)	Measurement Result (dB $\mu$ V/m)	Cable loss (dB)	Antenna Factor (dB/m)	Receiver Reading (dB $\mu$ V)	Limit (dB $\mu$ V/m)	Margin (dB)	Antenna Pol. (H/V)	Antenna Height (cm)	Turntable angle (deg)
5458.550	61.5	-33.2	34.5	60.24	74.0	12.5	V	155	88
5459.710	61.6	-33.3	34.5	60.35	74.0	12.4	H	155	110
11000.000	48.7	-30.1	37.8	41.03	74.0	25.3	V	155	132
16500.000	54.8	-27.0	41.3	40.46	74.0	19.3	H	155	154
17172.800	55.4	-26.3	41.5	40.13	74.0	18.6	V	155	176
17670.550	55.2	-26.5	41.2	40.46	74.0	18.8	V	155	198

## Channel 120

Frequency (MHz)	Measurement Result (dB $\mu$ V/m)	Cable loss (dB)	Antenna Factor (dB/m)	Receiver Reading (dB $\mu$ V)	Limit (dB $\mu$ V/m)	Margin (dB)	Antenna Pol. (H/V)	Antenna Height (cm)	Turntable angle (deg)
5525.400	48.3	-34.4	34.5	48.13	74.0	25.7	V	155	176
5668.800	49.4	-32.6	34.7	47.27	74.0	24.6	H	155	198
11200.000	47.8	-30.3	38.0	40.13	74.0	26.2	V	155	220
16800.000	54.9	-26.8	41.5	40.11	74.0	19.1	H	155	198
17302.600	54.9	-26.8	41.4	40.28	74.0	19.1	H	155	242
17952.780	55.0	-26.0	41.3	39.66	74.0	19.0	V	155	264



**Channel 140**

Frequency (MHz)	Measurement Result (dBμV/m)	Cable loss (dB)	Antenna Factor (dB/m)	Receiver Reading (dBμV)	Limit (dBμV/m)	Margin (dB)	Antenna Pol. (H/V)	Antenna Height (cm)	Turntable angle (deg)
5725.080	61.3	-33.6	34.8	60.08	74.0	12.7	V	155	44
5725.740	60.7	-33.6	34.8	59.45	74.0	13.3	H	155	66
11400.000	48.4	-30.4	38.1	40.66	74.0	25.6	H	155	88
17100.000	55.0	-26.1	41.6	39.50	74.0	19.0	V	155	110
16987.450	55.3	-26.8	41.7	40.39	74.0	18.7	V	155	132
17670.550	55.2	-26.5	41.2	40.46	74.0	18.8	H	155	154

**802.11ac-HT40**
**Channel 38**

Frequency (MHz)	Measurement Result (dBμV/m)	Cable loss (dB)	Antenna Factor (dB/m)	Receiver Reading (dBμV)	Limit (dBμV/m)	Margin (dB)	Antenna Pol. (H/V)	Antenna Height (cm)	Turntable angle (deg)
5142.710	60.3	-34.9	34.2	60.99	74.0	13.7	H	155	88
5143.140	60.3	-34.9	34.2	60.98	74.0	13.7	H	155	66
10379.750	47.6	-29.7	37.5	39.82	74.0	26.4	H	155	110
15570.100	54.8	-27.6	40.2	42.21	74.0	19.2	V	155	0
16944.000	54.8	-27.1	41.7	40.24	74.0	19.2	H	155	22
17184.350	55.9	-26.3	41.5	40.76	74.0	18.1	H	155	44

**Channel 46**

Frequency (MHz)	Measurement Result (dBμV/m)	Cable loss (dB)	Antenna Factor (dB/m)	Receiver Reading (dBμV)	Limit (dBμV/m)	Margin (dB)	Antenna Pol. (H/V)	Antenna Height (cm)	Turntable angle (deg)
5133.200	50.5	-35.0	34.2	51.32	74.0	23.5	H	155	132
5316.400	49.9	-34.9	34.4	50.50	74.0	24.1	H	155	154
10460.050	47.6	-30.9	37.6	40.95	74.0	26.4	H	155	88
15690.000	50.5	-27.4	40.3	37.62	74.0	23.5	V	155	110
16516.100	54.2	-26.9	41.3	39.84	74.0	19.8	V	155	44
17069.400	54.9	-26.3	41.6	39.49	74.0	19.1	H	155	0

## Channel 54

Frequency (MHz)	Measurement Result (dB $\mu$ V/m)	Cable loss (dB)	Antenna Factor (dB/m)	Receiver Reading (dB $\mu$ V)	Limit (dB $\mu$ V/m)	Margin (dB)	Antenna Pol. (H/V)	Antenna Height (cm)	Turntable angle (deg)
5217.000	58.3	-34.3	34.3	58.40	68.3	10.0	H	155	88
5321.200	58.2	-34.9	34.4	58.78	68.3	10.1	H	155	66
10539.800	45.7	-31.3	37.6	39.42	68.3	22.6	H	155	110
15809.900	51.1	-27.6	40.5	38.30	68.3	17.2	V	155	0
16331.850	53.6	-26.7	41.1	39.22	68.3	14.7	H	155	22
16944.000	55.1	-27.1	41.7	40.49	68.3	13.2	H	155	44

## Channel 62

Frequency (MHz)	Measurement Result (dB $\mu$ V/m)	Cable loss (dB)	Antenna Factor (dB/m)	Receiver Reading (dB $\mu$ V)	Limit (dB $\mu$ V/m)	Margin (dB)	Antenna Pol. (H/V)	Antenna Height (cm)	Turntable angle (deg)
5350.800	60.5	-34.6	34.4	60.64	68.3	7.8	H	155	22
5352.365	60.3	-34.5	34.4	60.42	68.3	8.0	H	155	330
10620.100	45.7	-28.8	37.6	36.85	68.3	22.6	H	155	242
15929.800	51.6	-27.2	40.6	38.24	68.3	16.7	V	155	264
16539.200	53.3	-26.8	41.3	38.82	68.3	15.0	V	155	286
17014.400	55.6	-26.6	41.7	40.54	68.3	12.7	V	155	308

## Channel 102

Frequency (MHz)	Measurement Result (dB $\mu$ V/m)	Cable loss (dB)	Antenna Factor (dB/m)	Receiver Reading (dB $\mu$ V)	Limit (dB $\mu$ V/m)	Margin (dB)	Antenna Pol. (H/V)	Antenna Height (cm)	Turntable angle (deg)
5455.405	59.9	-33.2	34.5	58.58	74.0	14.1	V	155	176
5456.020	60.0	-33.2	34.5	58.75	74.0	14.0	H	155	198
11020.000	47.6	-30.7	37.8	40.50	74.0	26.4	V	155	220
16530.000	54.0	-26.9	41.3	39.61	74.0	20.0	H	155	198
16940.150	55.3	-27.1	41.7	40.70	74.0	18.7	H	155	242
17941.750	55.0	-26.0	41.3	39.70	74.0	19.0	V	155	264

**Channel 118**

Frequency (MHz)	Measurement Result (dBμV/m)	Cable loss (dB)	Antenna Factor (dB/m)	Receiver Reading (dBμV)	Limit (dBμV/m)	Margin (dB)	Antenna Pol. (H/V)	Antenna Height (cm)	Turntable angle (deg)
5519.600	49.9	-34.3	34.5	49.70	74.0	24.1	H	155	88
5669.000	50.1	-32.6	34.7	47.96	74.0	23.9	H	155	110
11180.000	47.6	-30.1	37.9	39.81	74.0	26.4	H	155	88
16770.000	54.0	-26.7	41.5	39.27	74.0	20.0	V	155	110
17056.750	55.1	-26.3	41.6	39.85	74.0	18.9	V	155	132
17650.280	54.7	-26.5	41.2	39.93	74.0	19.3	H	155	154

**Channel 134**

Frequency (MHz)	Measurement Result (dBμV/m)	Cable loss (dB)	Antenna Factor (dB/m)	Receiver Reading (dBμV)	Limit (dBμV/m)	Margin (dB)	Antenna Pol. (H/V)	Antenna Height (cm)	Turntable angle (deg)
5726.490	54.0	-33.6	34.8	52.77	74.0	20.0	H	155	176
5730.620	53.8	-33.7	34.8	52.63	74.0	20.2	H	155	0
11340.000	47.4	-30.5	38.1	39.79	74.0	26.6	V	155	22
17010.000	54.1	-26.6	41.7	39.10	74.0	19.9	V	155	352
16709.700	55.1	-26.7	41.5	40.34	74.0	18.9	V	155	0
17203.050	54.9	-26.4	41.5	39.80	74.0	19.1	H	155	0

**802.11ac-HT80**
**Channel 42**

Frequency (MHz)	Measurement Result (dBμV/m)	Cable loss (dB)	Antenna Factor (dB/m)	Receiver Reading (dBμV)	Limit (dBμV/m)	Margin (dB)	Antenna Pol. (H/V)	Antenna Height (cm)	Turntable angle (deg)
5130.285	60.3	-35.0	34.2	61.14	68.3	13.7	H	155	0
5130.495	60.4	-35.0	34.2	61.16	68.3	13.6	H	155	0
10420.000	48.1	-29.8	37.5	40.28	68.3	20.2	V	155	22
15630.000	51.1	-27.4	40.3	38.25	68.3	17.2	V	155	352
17081.560	55.6	-26.2	41.6	40.17	68.3	12.7	V	155	88
17723.950	55.1	-26.5	41.2	40.39	68.3	13.2	V	155	88

## Channel 58

Frequency (MHz)	Measurement Result (dB $\mu$ V/m)	Cable loss (dB)	Antenna Factor (dB/m)	Receiver Reading (dB $\mu$ V)	Limit (dB $\mu$ V/m)	Margin (dB)	Antenna Pol. (H/V)	Antenna Height (cm)	Turntable angle (deg)
5355.335	59.3	-34.5	34.4	59.35	68.3	14.7	V	155	176
5355.605	59.5	-34.5	34.4	59.59	68.3	14.5	H	155	198
10580.000	47.6	-30.0	37.6	39.94	68.3	20.7	V	155	220
15870.000	51.2	-27.4	40.5	38.05	68.3	17.1	H	155	198
17264.180	55.3	-26.7	41.4	40.66	68.3	13.0	H	155	242
17913.160	54.6	-26.1	41.3	39.47	68.3	13.7	V	155	264

## Channel 106

Frequency (MHz)	Measurement Result (dB $\mu$ V/m)	Cable loss (dB)	Antenna Factor (dB/m)	Receiver Reading (dB $\mu$ V)	Limit (dB $\mu$ V/m)	Margin (dB)	Antenna Pol. (H/V)	Antenna Height (cm)	Turntable angle (deg)
5459.535	59.4	-33.2	34.5	58.21	68.3	14.6	H	155	0
5459.960	58.9	-33.3	34.5	57.74	68.3	15.1	H	155	44
11060.000	47.6	-31.3	37.8	41.04	68.3	20.7	V	155	88
16590.000	53.5	-26.6	41.4	38.73	68.3	14.8	V	155	44
17382.100	55.1	-26.5	41.3	40.27	68.3	13.2	V	155	66
16950.680	55.6	-27.0	41.7	41.02	68.3	12.7	H	155	88

Sample:

5459.535MHz

 Result (59.4dB $\mu$ V/m)= P<sub>Mea</sub>(58.21 dB $\mu$ V/m)+ Cable Loss(-33.2 dB) + Antenna Factor(34.5 dB/m)

## A.7. AC Powerline Conducted Emission (150kHz- 30MHz)

**Method of Measurement: See ANSI C63.10-2013-clause 6.2**

### Setup:

A stand-alone EUT shall be placed in the center along the back edge of the tabletop. For multiunit tabletop systems, the EUT shall be centered laterally (left to right facing the tabletop) on the tabletop and its rear shall be flush with the rear of the table.

Accessories that are part of an EUT system tested on a tabletop shall be placed in a test arrangement on one or both sides of the host with a 10 cm separation between the nearest points of the cabinets. The rear of the host and accessories shall be flush with the back of the supporting tabletop unless that would not be typical of normal use. If more than two accessories are present, then an equipment test arrangement shall be chosen that maintains 10 cm spacing between cabinets unless the equipment is normally located closer together.

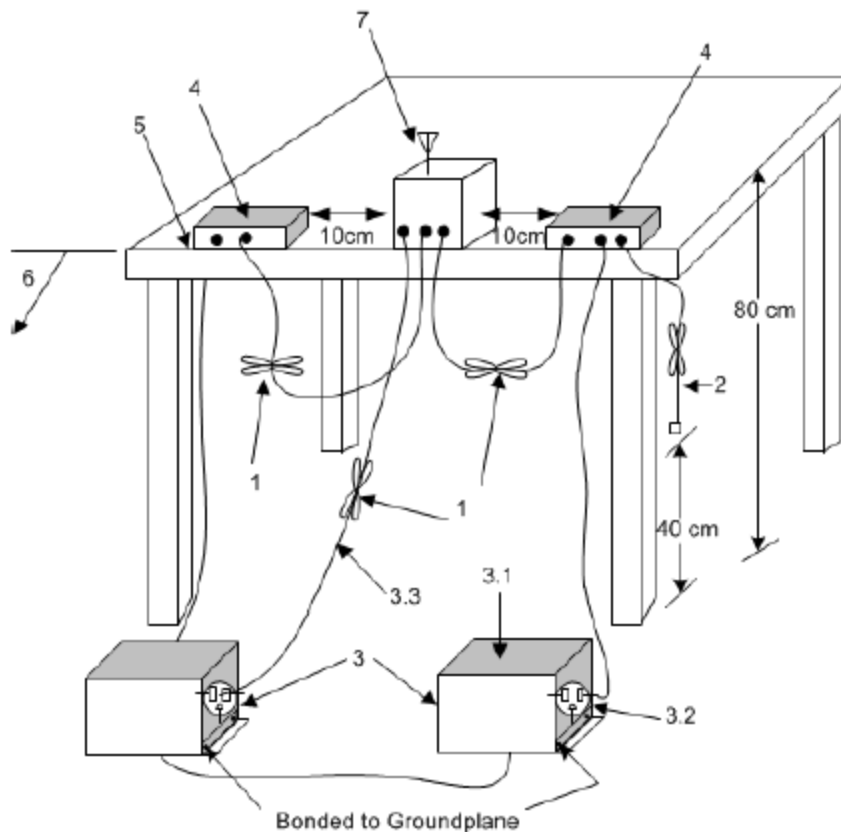

### Exploratory ac power-line conducted emission measurements

Exploratory measurements shall be used to identify the frequency of the emission that has the highest amplitude relative to the limit by operating the EUT in a range of typical modes of operation, cable positions, and with a typical system equipment configuration and arrangement. For each mode of operation and for each ac power current-carrying conductor, cable manipulation shall be performed within the range of likely configurations. For this measurement or series of measurements, the frequency spectrum of interest shall be monitored looking for the emission that has the highest amplitude relative to the limit. Once that emission is found for each current-carrying conductor of each power cord associated with the EUT (but not the cords

associated with non-EUT equipment in the overall system), the one configuration and arrangement and mode of operation that produces the emission closest to the limit over all of the measured conductors shall be recorded.

**Final ac power-line conducted emission measurements**

Based on the exploratory tests of the EUT, the one EUT cable configuration and arrangement and mode of operation that produced the emission with the highest amplitude relative to the limit is selected for the final measurement, while applying the appropriate modulating signal to the EUT. If the EUT is relocated from an exploratory test site to a final test site, the highest emissions shall be remaximized at the final test location before final ac power-line conducted emission measurements are performed. The final test on all current-carrying conductors of all of the power cords to the equipment that comprises the EUT (but not the cords associated with other non-EUT equipment in the system) is then performed for the full frequency range for which the EUT is being tested for compliance without further variation of the EUT arrangement, cable positions, or EUT mode of operation. If the EUT is composed of equipment units that have their own separate ac power connections (e.g., floor-standing equipment with independent power cords for each shelf that are able to connect directly to the ac power network), then each current-carrying conductor of one unit is measured while the other units are connected to a second (or more) LISN(s). All units shall be measured separately. If a power strip is provided by the manufacturer, to supply all of the units making up the EUT, only the conductors in the power cord of the power strip shall be measured.

**Test Condition:**

Voltage (V)	Frequency (Hz)
120	60

**Measurement Result and limit:**

**EUT ID: EUT1**

WLAN (Quasi-peak Limit)

Frequency range (MHz)	Quasi-peak Limit (dB $\mu$ V)	Result (dB $\mu$ V)		Conclusion
		With charger		
		11a mode	Idle	
0.15 to 0.5	66 to 56	Fig.75	Fig.76	P
0.5 to 5	56			
5 to 30	60			

NOTE: The limit decreases linearly with the logarithm of the frequency in the range 0.15 MHz to 0.5 MHz.

WLAN (Average Limit)

Frequency range (MHz)	Average Limit (dB $\mu$ V)	Result (dB $\mu$ V)		Conclusion
		With charger		
		11a mode	Idle	
0.15 to 0.5	56 to 46	Fig.75	Fig.76	P
0.5 to 5	46			
5 to 30	50			

NOTE: The limit decreases linearly with the logarithm of the frequency in the range 0.15 MHz to 0.5 MHz.

**Conclusion: PASS**

Test graphs as below:

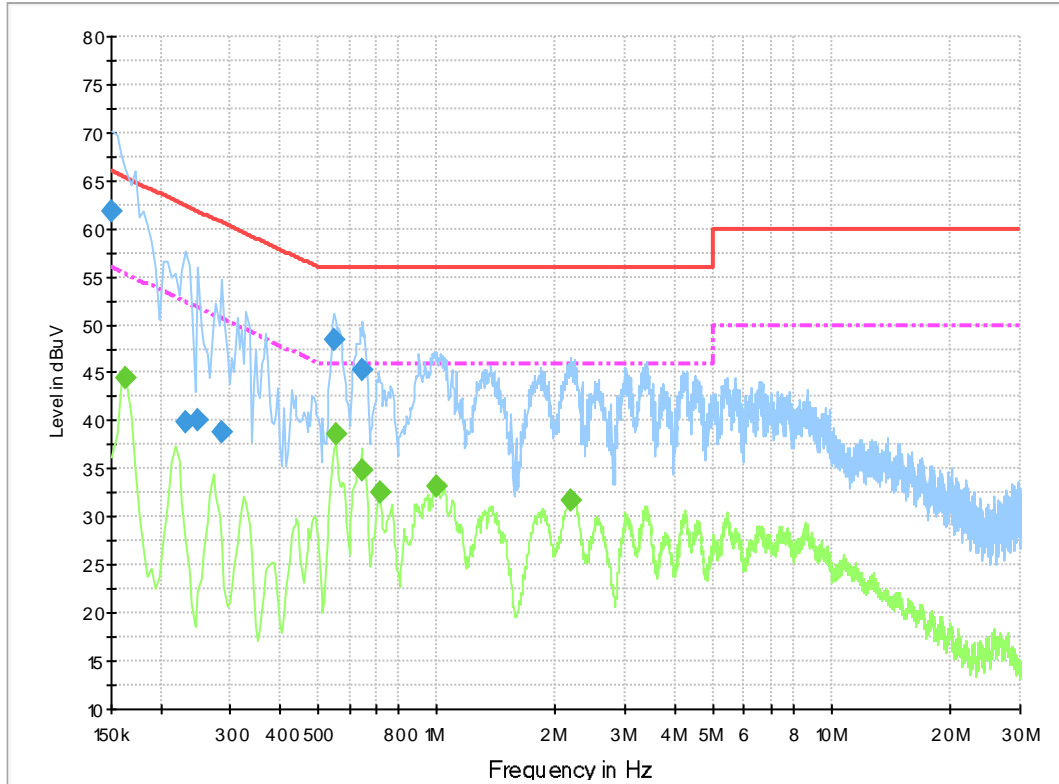

**Fig.75 Conducted Emission(802.11a, Ch40, TX)**

**Final Result 1**

Frequency (MHz)	QuasiPeak (dB $\mu$ V)	Line	Margin (dB)	Limit (dB $\mu$ V)
0.150000	61.9	L1	4.1	66.0
0.231000	39.9	N	22.5	62.4
0.249000	40.2	N	21.6	61.8
0.285000	38.9	N	21.8	60.7
0.550500	48.4	L1	7.6	56.0
0.649500	45.4	L1	10.6	56.0

**Final Result 2**

Frequency (MHz)	Average (dB $\mu$ V)	Line	Margin (dB)	Limit (dB $\mu$ V)
0.163500	44.5	N	10.8	55.3
0.555000	38.6	N	7.4	46.0
0.645000	34.9	N	11.1	46.0
0.717000	32.6	L1	13.4	46.0
1.000500	33.3	L1	12.7	46.0
2.184000	31.8	L1	14.2	46.0

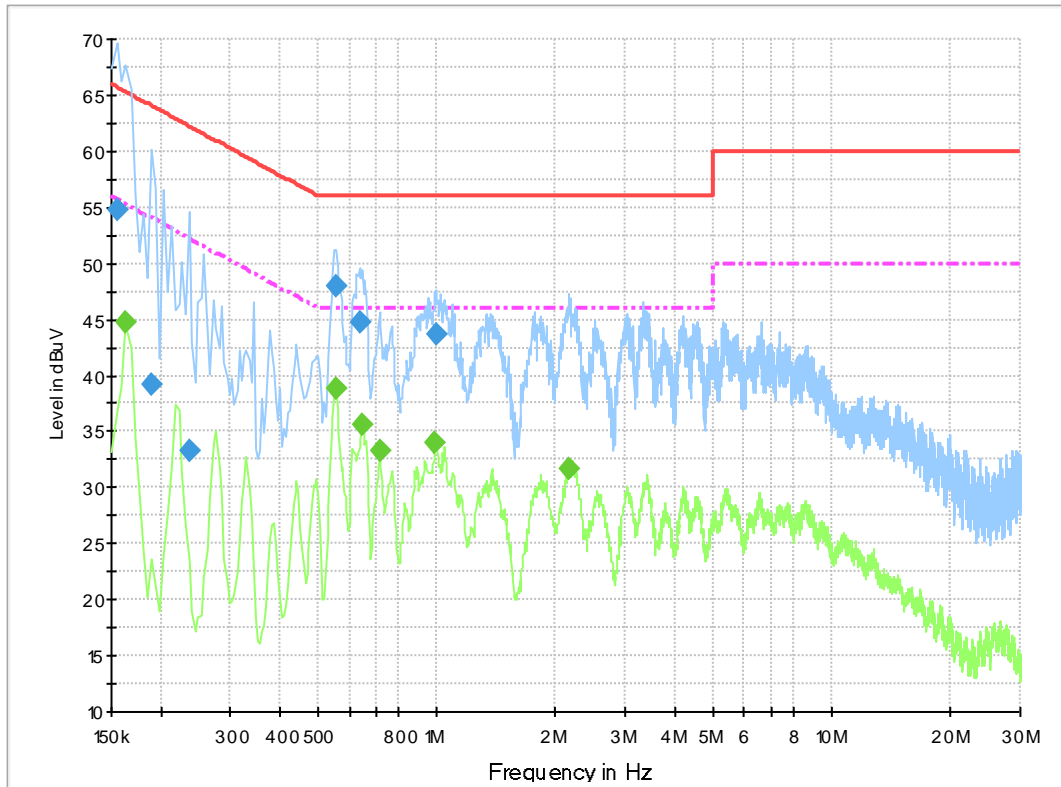

**Fig.76 Conducted Emission(802.11a, IDLE)**

**Final Result 1**

Frequency (MHz)	QuasiPeak (dB $\mu$ V)	Line	Margin (dB)	Limit (dB $\mu$ V)
0.154500	54.8	N	11.0	65.8
0.190500	39.1	N	24.9	64.0
0.235500	33.3	N	29.0	62.3
0.555000	47.9	L1	8.1	56.0
0.636000	44.7	L1	11.3	56.0
0.996000	43.8	L1	12.2	56.0

**Final Result 2**

Frequency (MHz)	Average (dB $\mu$ V)	Line	Margin (dB)	Limit (dB $\mu$ V)
0.163500	44.7	N	10.6	55.3
0.555000	38.8	N	7.2	46.0
0.649500	35.6	N	10.4	46.0
0.717000	33.2	L1	12.8	46.0
0.991500	34.1	L1	11.9	46.0
2.161500	31.7	L1	14.3	46.0



### A.8. 99% Occupied bandwidth

Method of Measurement: See ANSI C63.10-2013-clause 12.4.2.

- a) The instrument center frequency is set to the nominal EUT channel center frequency. The frequency span for the spectrum analyzer shall be between 1.5 times and 5.0 times the OBW.
- b) The nominal IF filter bandwidth (3 dB RBW) shall be in the range of 1% to 5% of the OBW, and VBW shall be approximately three times the RBW, unless otherwise specified by the applicable requirement.
- c) Set the reference level of the instrument as required, keeping the signal from exceeding the maximum input mixer level for linear operation. In general, the peak of the spectral envelope shall be more than  $[10 \log (OBW/RBW)]$  below the reference level. Specific guidance is given in 4.1.5.2.
- d) Step a) through step c) might require iteration to adjust within the specified range.
- e) Video averaging is not permitted. Where practical, a sample detection and single sweep mode shall be used. Otherwise, peak detection and max hold mode (until the trace stabilizes) shall be used.
- f) Use the 99% power bandwidth function of the instrument (if available) and report the measured bandwidth.
- g) If the instrument does not have a 99% power bandwidth function, then the trace data points are recovered and directly summed in linear power terms. The recovered amplitude data points, beginning at the lowest frequency, are placed in a running sum until 0.5% of the total is reached; that frequency is recorded as the lower frequency. The process is repeated until 99.5% of the total is reached; that frequency is recorded as the upper frequency. The 99% power bandwidth is the difference between these two frequencies.
- h) The occupied bandwidth shall be reported by providing plot(s) of the measuring instrument display; the plot axes and the scale units per division shall be clearly labeled. Tabular data may be reported in addition to the plot(s).

#### Measurement Uncertainty:

Measurement Uncertainty	60.80Hz
-------------------------	---------

#### Measurement Result:

Mode	Frequency	99% Occupied bandwidth ( MHz)		conclusion
		Fig.	Value	
802.11a	5180 MHz	Fig.77	17.12	P
	5200 MHz	Fig.78	17.12	P
	5240 MHz	Fig.79	17.11	P
802.11n HT20	5180 MHz	Fig.80	18.29	P
	5200 MHz	Fig.81	18.25	P
	5240 MHz	Fig.82	18.30	P
802.11ac HT20	5180 MHz	Fig.83	18.32	P
	5200 MHz	Fig.84	18.27	P
	5240 MHz	Fig.85	18.32	P
802.11n HT40	5190 MHz	Fig.86	36.28	P
	5230 MHz	Fig.87	36.36	P
802.11ac	5190 MHz	Fig.88	36.28	P

HT40	5230 MHz	Fig.89	36.36	P
802.11ac HT80	5210 MHz	Fig.90	75.66	P

**Conclusion: PASS**

Test graphs as below:

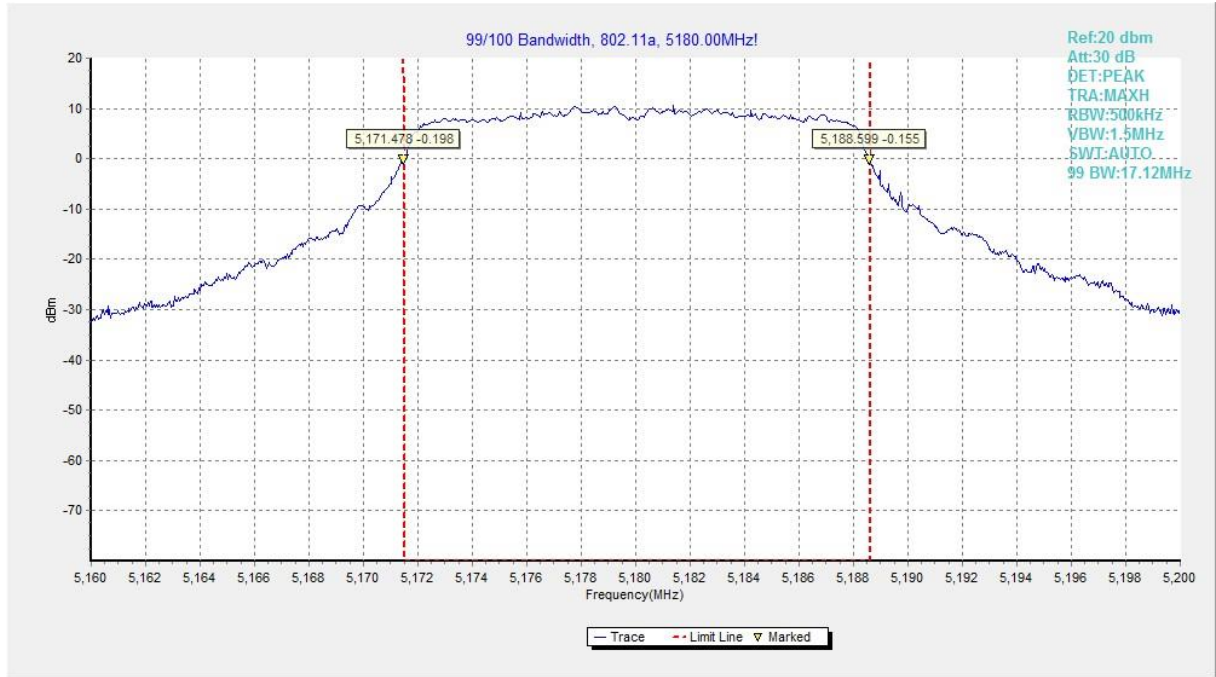

**Fig.77 99% Occupied bandwidth (802.11a, 5180MHz)**

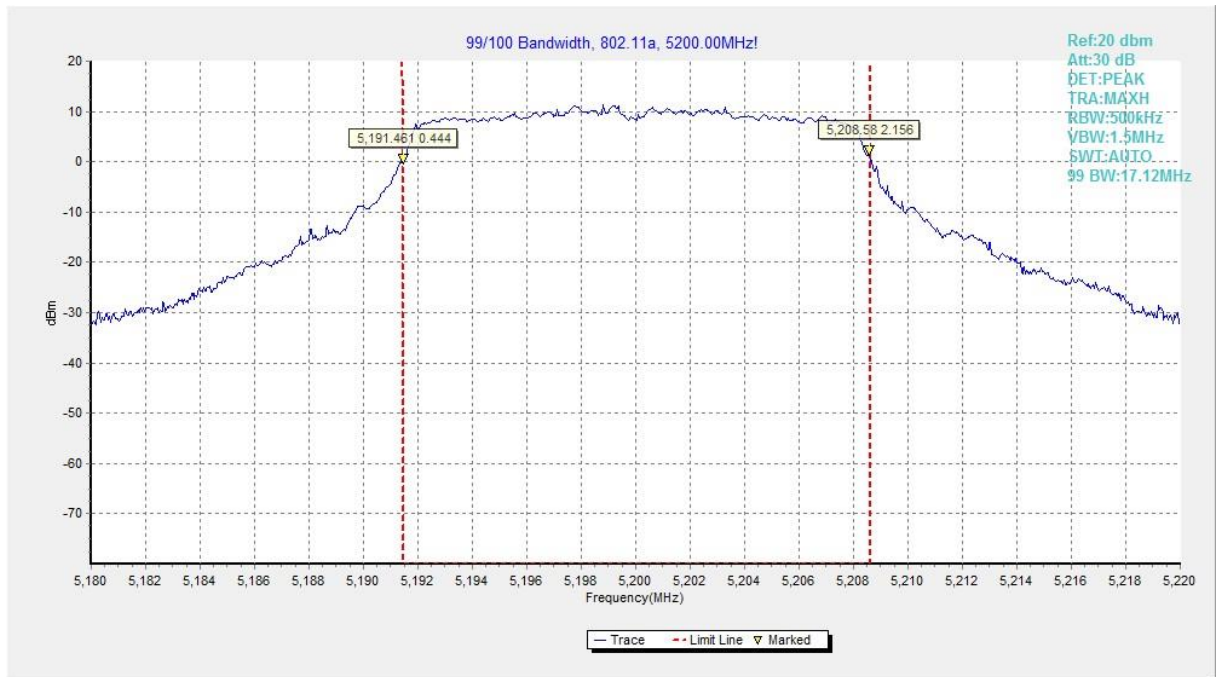

**Fig.78 99% Occupied bandwidth (802.11a, 5200MHz)**

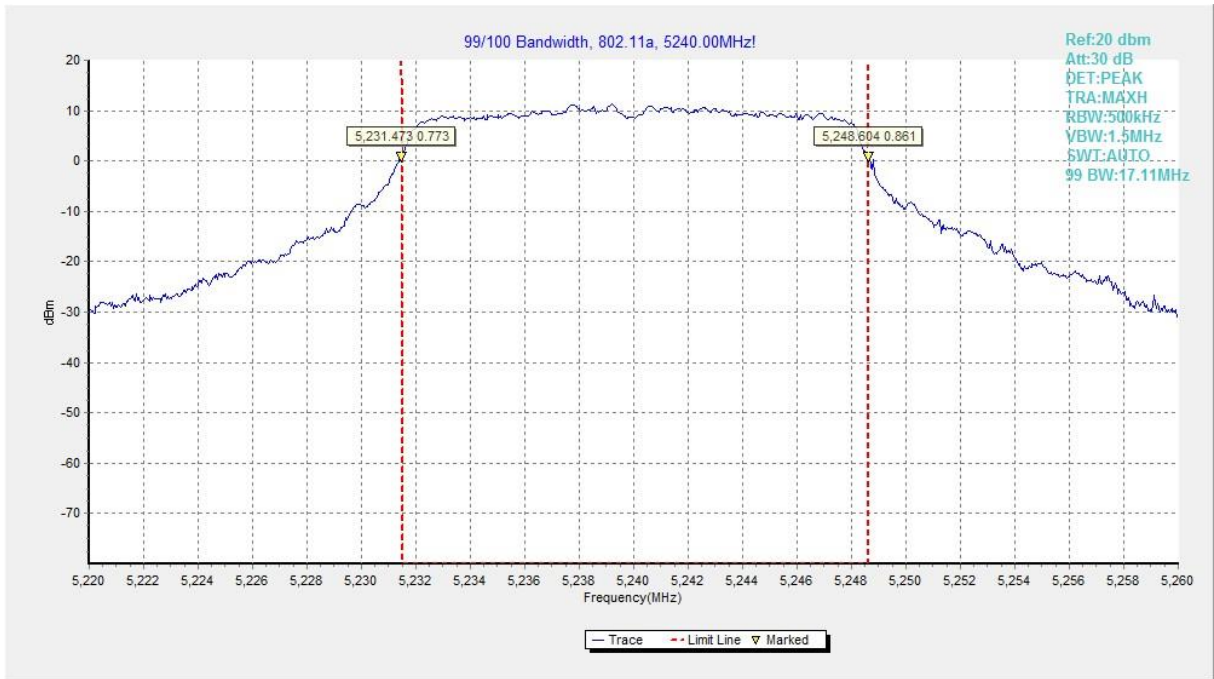

**Fig.79 99% Occupied bandwidth (802.11a, 5240MHz)**

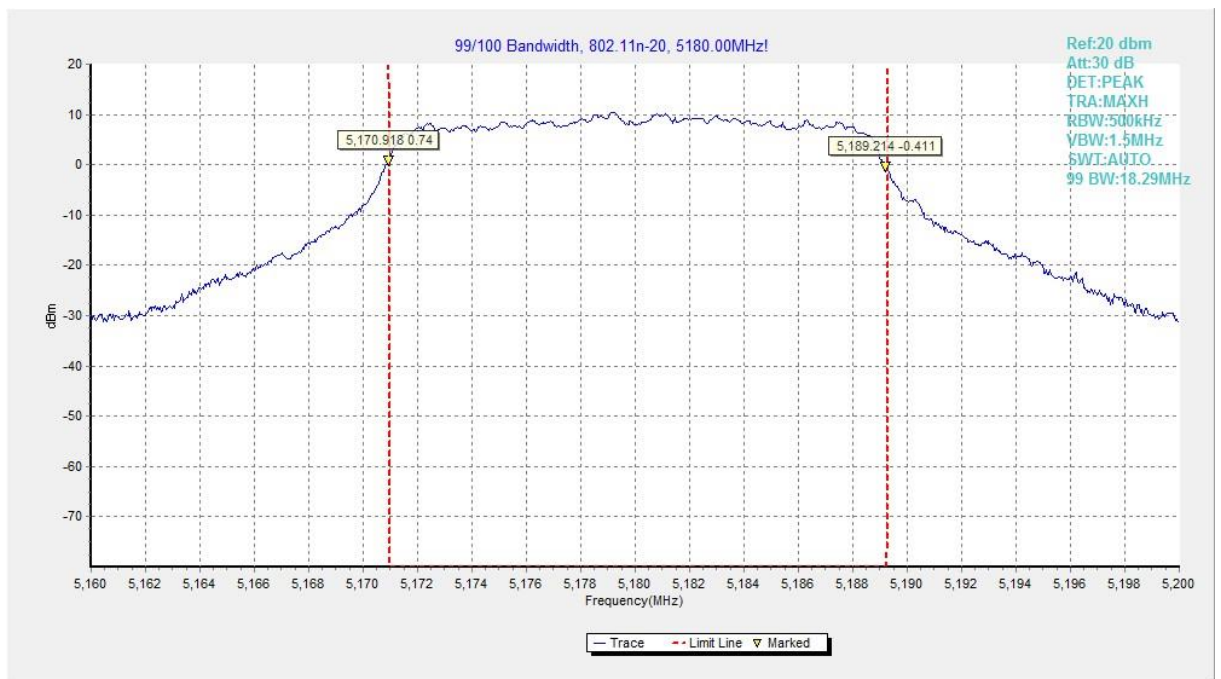

**Fig.80 99% Occupied bandwidth (802.11n-HT20, 5180MHz)**

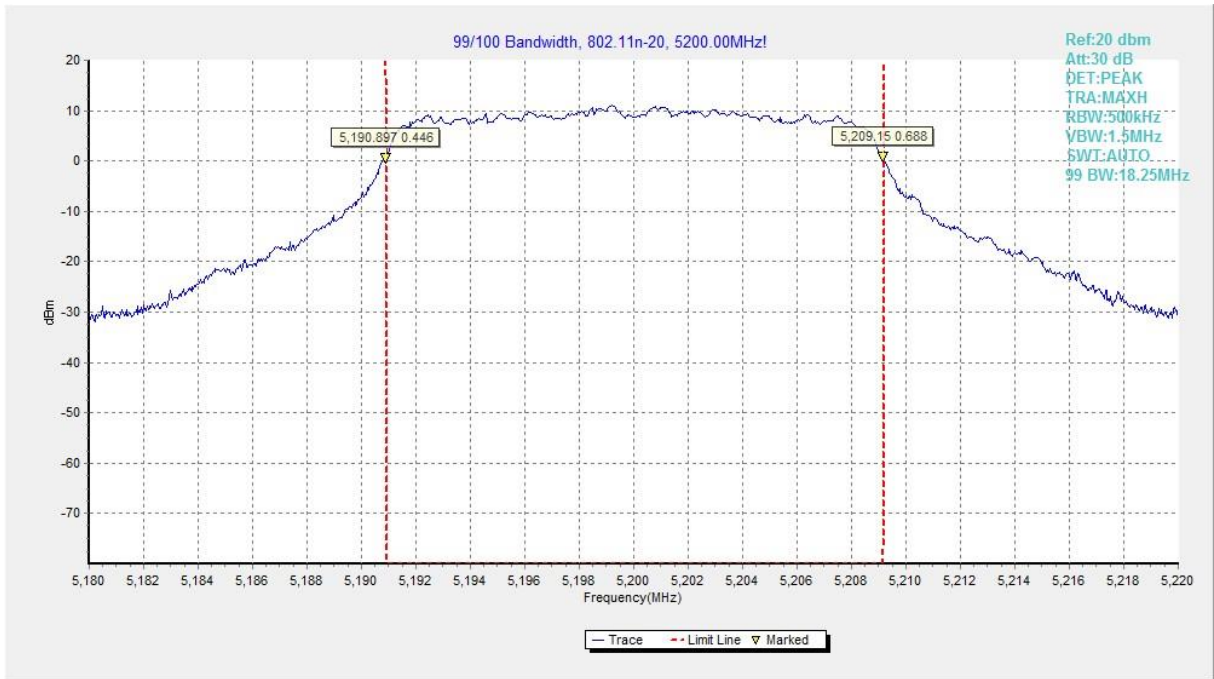

**Fig.81 99% Occupied bandwidth (802.11n-HT20, 5200MHz)**

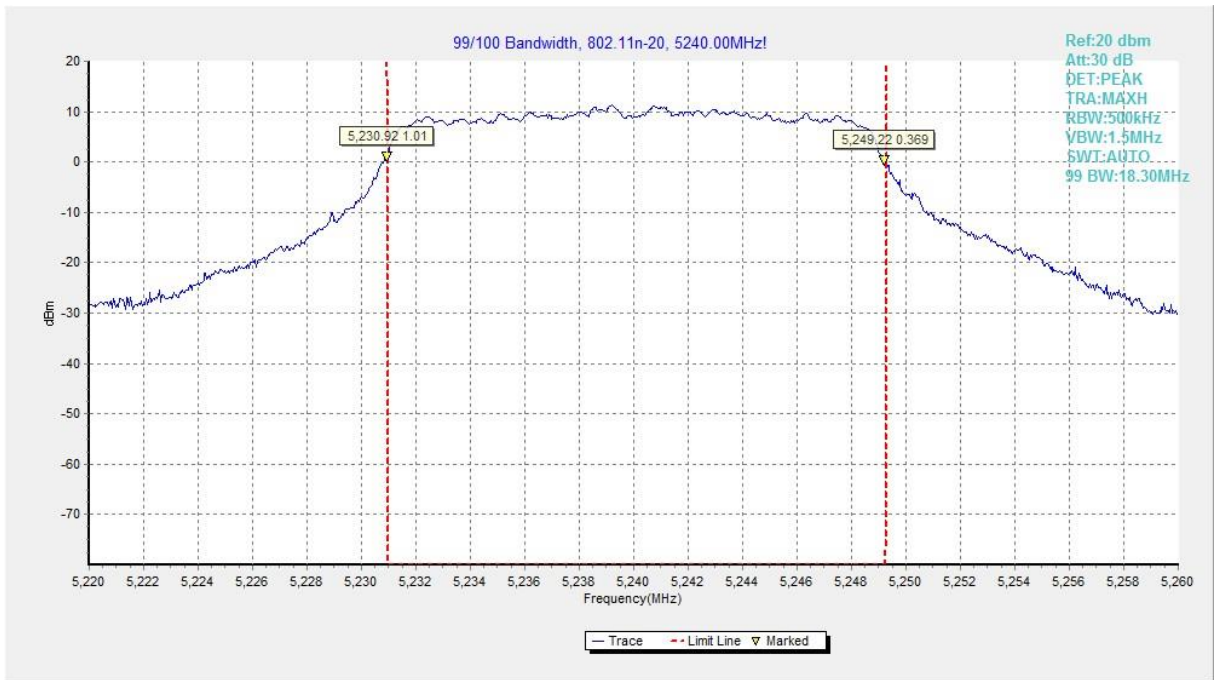

**Fig.82 99% Occupied bandwidth (802.11n-HT20, 5240MHz)**

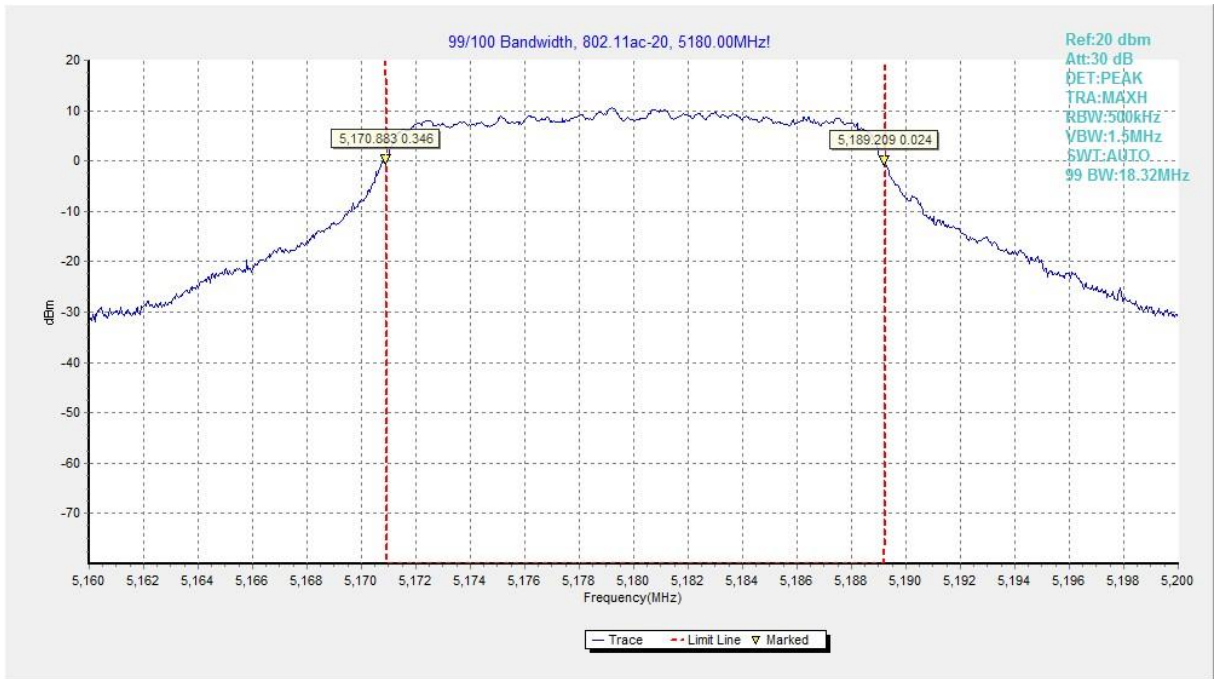

**Fig.83 99% Occupied bandwidth (802.11ac-HT20, 5180MHz)**

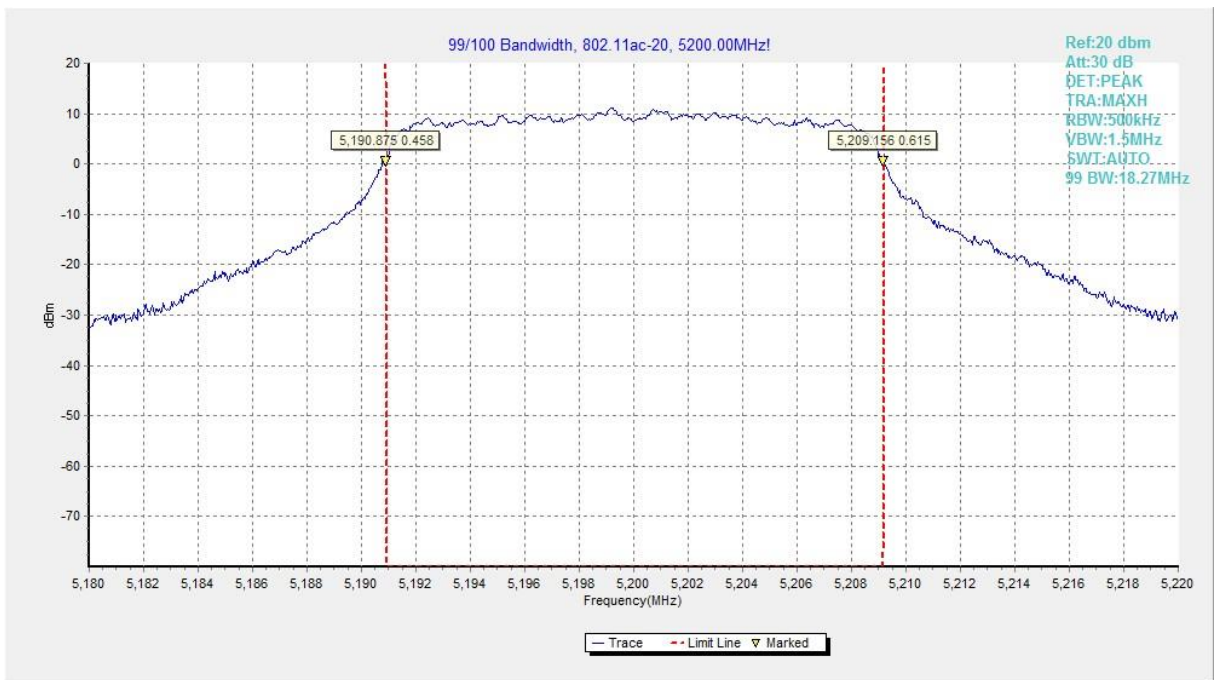

**Fig.84 99% Occupied bandwidth (802.11ac-HT20, 5200MHz)**

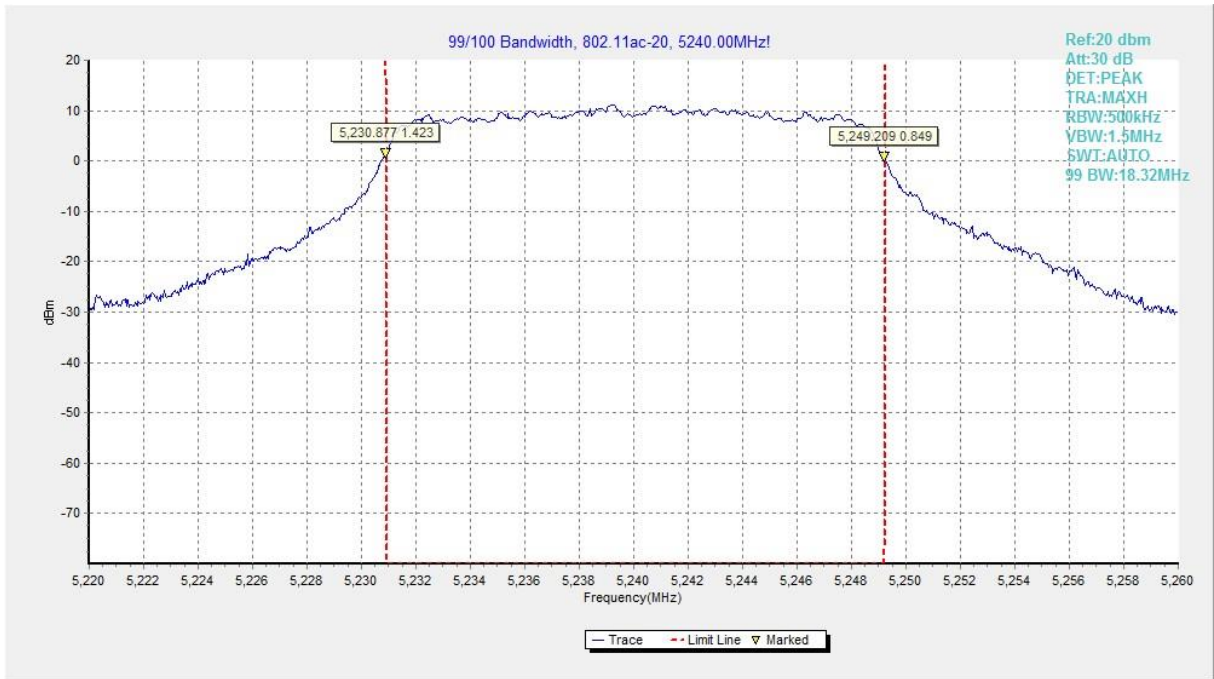

**Fig.85 99% Occupied bandwidth (802.11ac-HT20, 5240MHz)**

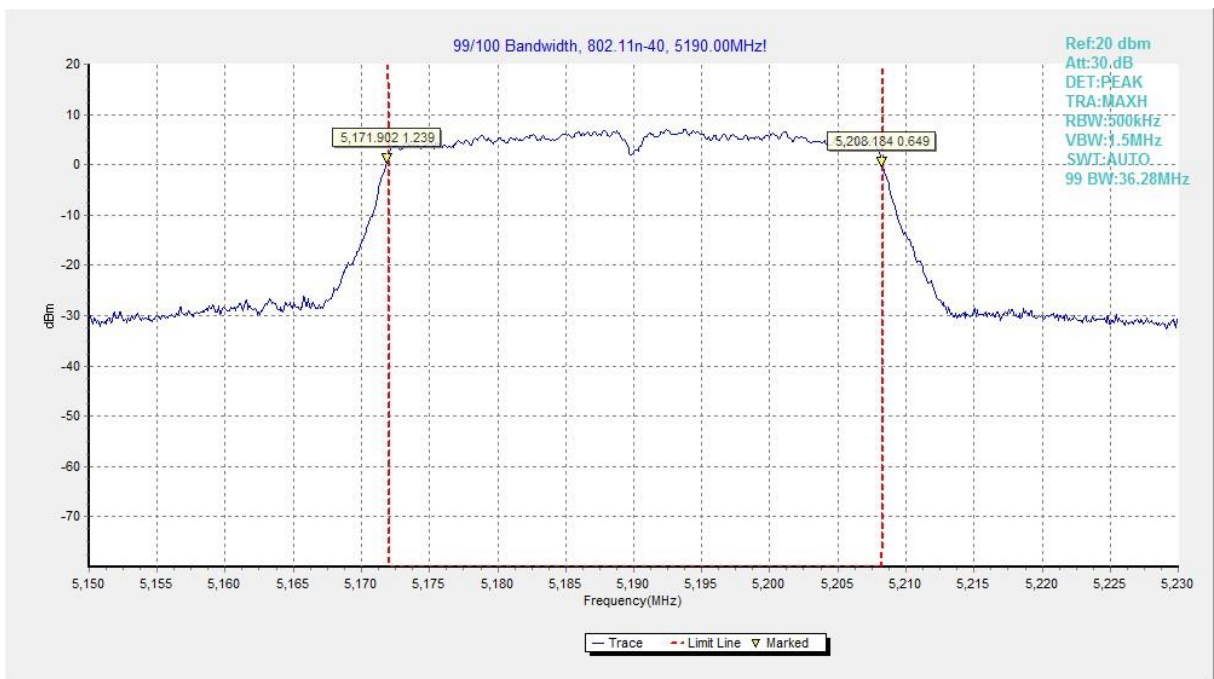

**Fig.86 99% Occupied bandwidth (802.11n-HT40, 5190MHz)**

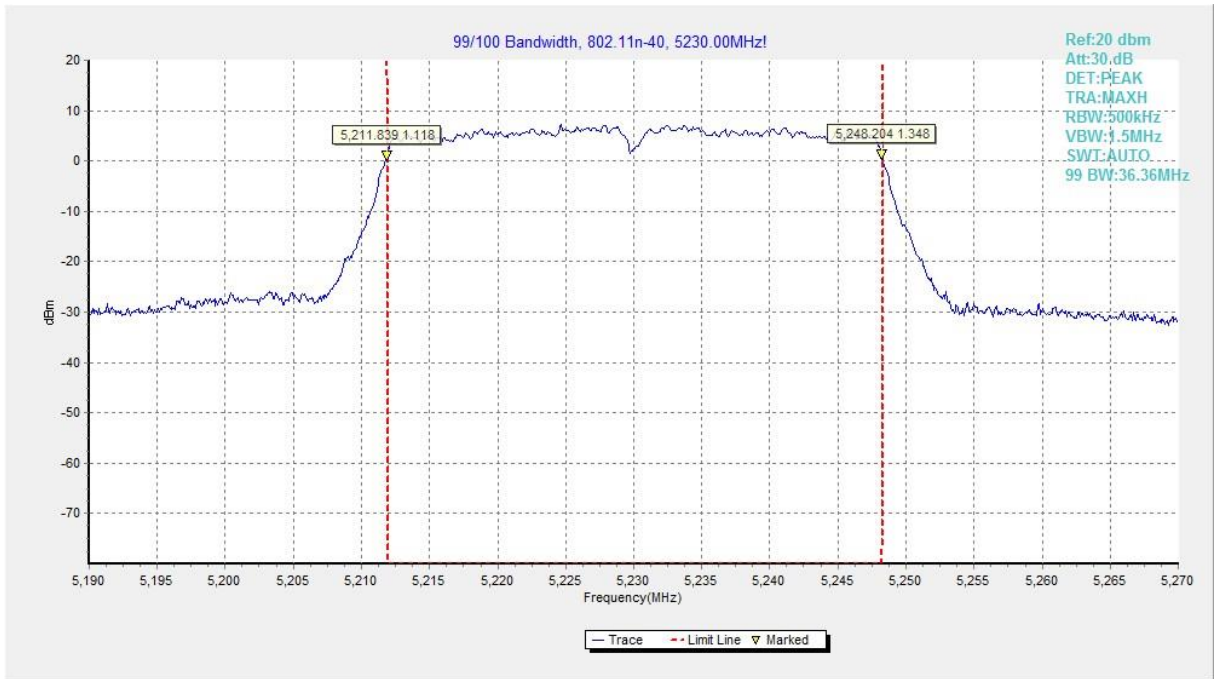

**Fig.87 99% Occupied bandwidth (802.11n-HT40, 5230MHz)**

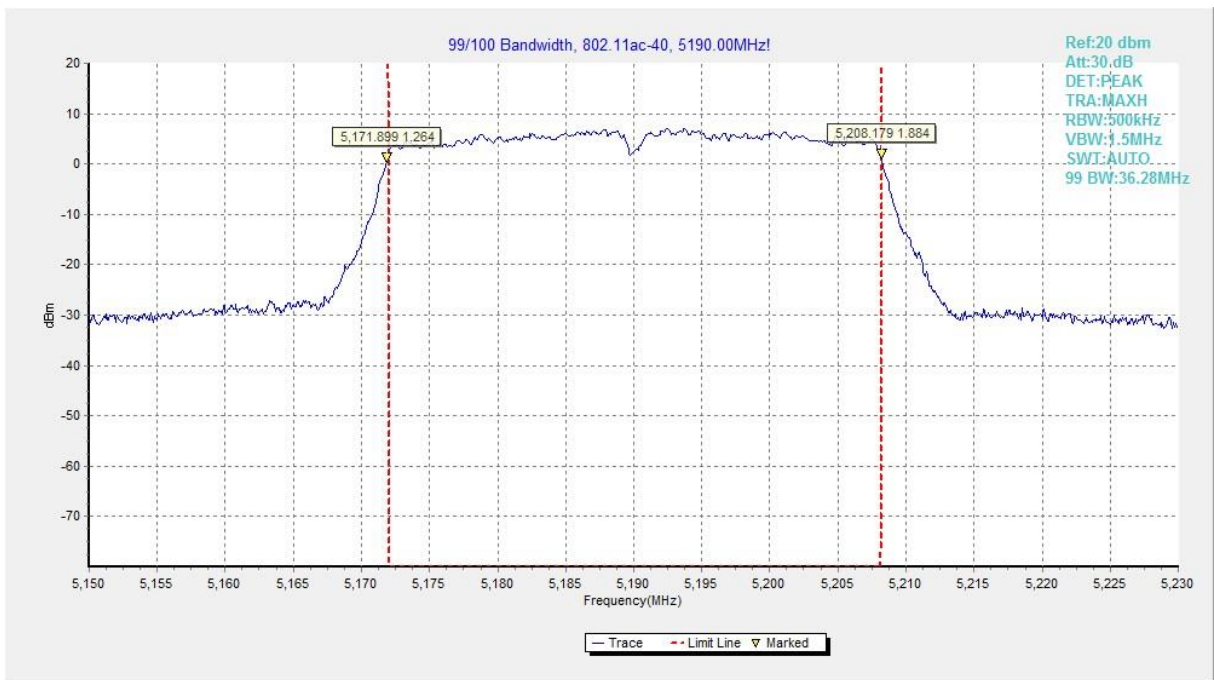

**Fig.88 99% Occupied bandwidth (802.11ac-HT40, 5190MHz)**

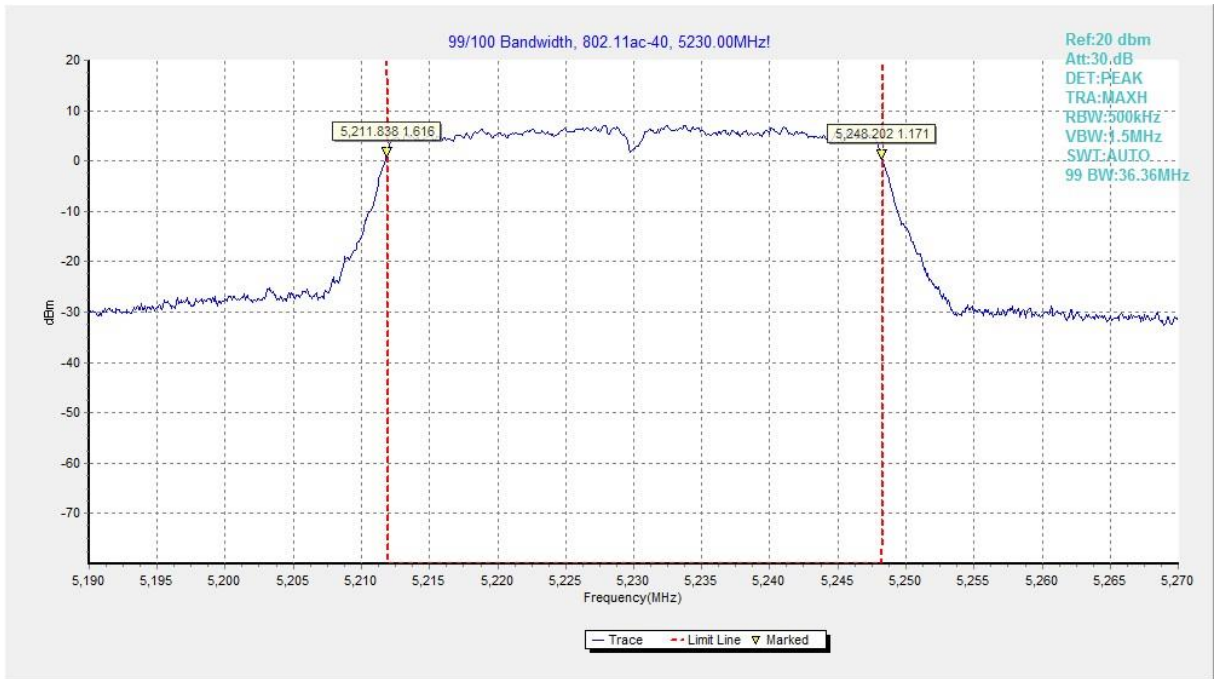

**Fig.89 99% Occupied bandwidth (802.11ac-HT40, 5230MHz)**

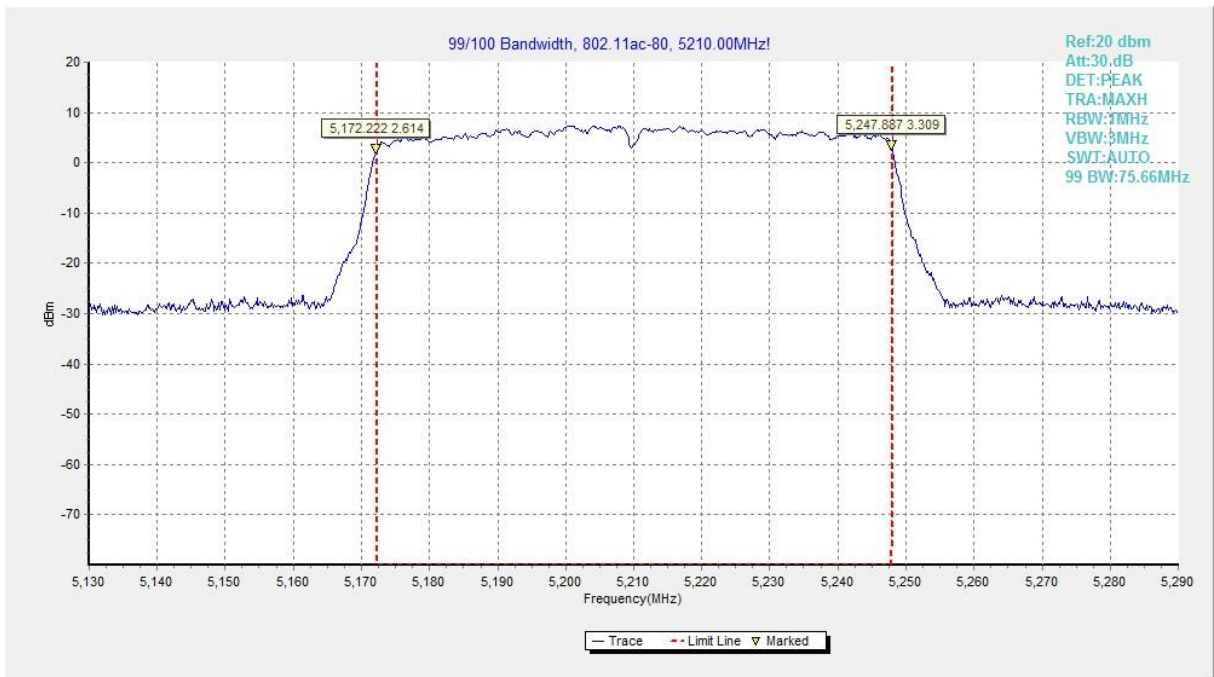

**Fig.90 99% Occupied bandwidth (802.11ac-HT80, 5210MHz)**



### A.9. Frequency Stability

Manufacturers ensured the EUT meet the requirement of frequency stability, such that an emission is maintained within the band of operation under all conditions of normal operation as specified in the user's manual.

#### Measurement Result:

Mode	Frequency	Test Condition		Result(MHz)
802.11a	5200MHz	Tnom	Vnom	0.03
		Tmax	Vnom	
		Tmin	Vnom	
		Vmax	Tnom	
		Vmin	Tnom	

### A.10. Power control

A Transmission Power Control mechanism is not required for systems with an e.i.r.p. of less than 27dBm (500 mW).

## ANNEX B: Accreditation Certificate

<p>United States Department of Commerce National Institute of Standards and Technology</p> 	
<hr/> <p><b>Certificate of Accreditation to ISO/IEC 17025:2005</b></p> <hr/>	
<p>NVLAP LAB CODE: 600118-0</p>	
<p><b>Telecommunication Technology Labs, CAICT</b> Beijing China</p>	
<p><i>is accredited by the National Voluntary Laboratory Accreditation Program for specific services, listed on the Scope of Accreditation, for:</i></p>	
<p><b>Electromagnetic Compatibility &amp; Telecommunications</b></p>	
<p><i>This laboratory is accredited in accordance with the recognized International Standard ISO/IEC 17025:2005. This accreditation demonstrates technical competence for a defined scope and the operation of a laboratory quality management system (refer to joint ISO-ILAC-IAF Communiqué dated January 2009).</i></p>	
<hr/> <p>2019-09-26 through 2020-09-30 <i>Effective Dates</i></p>	 <hr/> <p><i>[Signature]</i> For the National Voluntary Laboratory Accreditation Program</p>

\*\*\* END OF REPORT BODY \*\*\*