



FCC RF Test Report

APPLICANT : TCL Communication Ltd.
EQUIPMENT : GSM/UMTS/LTE/NR Mobile phone
BRAND NAME : TCL
MODEL NAME : T803E
FCC ID : 2ACCJH183
STANDARD : 47 CFR Part 2, 22(H), 24(E), 27(L)
CLASSIFICATION : PCS Licensed Transmitter Held to Ear (PCE)
TEST DATE(S) : Mar. 14, 2024 ~ Mar. 24, 2024

We, Sporton International Inc. (Shenzhen), would like to declare that the tested sample has been evaluated in accordance with the procedures given in ANSI C63.26-2015 and shown compliance with the applicable technical standards.

The test results in this report apply exclusively to the tested model / sample. Without written approval of Sporton International Inc. (Shenzhen), the test report shall not be reproduced except in full.

Jason Jia



Approved by: Jason Jia

Sporton International Inc. (ShenZhen)

1/F, 2/F, Bldg 5, Shiling Industrial Zone, Xinwei Village, Xili, Nanshan, Shenzhen, 518055

People's Republic of China



TABLE OF CONTENTS

REVISION HISTORY...3
SUMMARY OF TEST RESULT...4
1 GENERAL DESCRIPTION...5
1.1 Applicant...5
1.2 Manufacturer...5
1.3 Product Feature of Equipment Under Test...5
1.4 Product Specification of Equipment Under Test...6
1.5 Modification of EUT...7
1.6 Maximum ERP/EIRP Power and Emission Designator...7
1.7 Testing Location...9
1.8 Test Software...9
1.9 Applicable Standards...10
2 TEST CONFIGURATION OF EQUIPMENT UNDER TEST...11
2.1 Test Mode...11
2.2 Connection Diagram of Test System...12
2.3 Support Unit used in test configuration and system...13
2.4 Measurement Results Explanation Example...13
2.5 Frequency List of Low/Middle/High Channels...14
3 CONDUCTED TEST ITEMS...17
3.1 Measuring Instruments...17
3.2 Test Setup...17
3.3 Test Result of Conducted Test...17
3.4 Conducted Output Power and ERP/EIRP...18
3.5 Peak-to-Average Ratio...19
3.6 Occupied Bandwidth...20
3.7 Conducted Band Edge...21
3.8 Conducted Spurious Emission...23
3.9 Frequency Stability...24
4 RADIATED TEST ITEMS...25
4.1 Measuring Instruments...25
4.2 Test Setup...25
4.3 Test Result of Radiated Test...26
4.4 Radiated Spurious Emission...27
5 LIST OF MEASURING EQUIPMENT...28
6 MEASUREMENT UNCERTAINTY...29
APPENDIX A. TEST RESULTS OF CONDUCTED TEST
APPENDIX B. TEST RESULTS OF RADIATED TEST
APPENDIX C. TEST SETUP PHOTOGRAPHS



REVISION HISTORY

REPORT NO.	VERSION	DESCRIPTION	ISSUED DATE
FG422702B	Rev. 01	Initial issue of report	Apr. 07, 2024



SUMMARY OF TEST RESULT

Report Section	FCC Rule	Description	Limit	Result	Remark
3.4	§2.1046	Conducted Output Power	-	Report Only	-
	§22.913(a)(5)	Effective Radiated Power (Band 5) (Band 26)	ERP < 7 Watt	PASS	-
	§24.232(c)	Equivalent Isotropic Radiated Power (Band 2) (Band 25)	EIRP < 2Watt		-
	§27.50(d)(4)	Equivalent Isotropic Radiated Power (Band 4) (Band 66)	EIRP < 1Watt		-
3.5	§24.232(d)	Peak-to-Average Ratio	<13 dB	PASS	-
3.6	§2.1049	Occupied Bandwidth	-	Report Only	-
3.7	§2.1051 §22.917(a) §24.238(a) §27.53(h)	Conducted Band Edge Measurement (Band 2) (Band 4) (Band 5) (Band 25) (Band 26) (Band 66)	< 43+10log ₁₀ (P[Watts])	PASS	-
3.8	§2.1051 §22.917(a) §24.238(a) §27.53(h)	Conducted Spurious Emission (Band 2) (Band 4) (Band 5) (Band 25) (Band 26) (Band 66)	< 43+10log ₁₀ (P[Watts])	PASS	-
3.9	§2.1055 §22.355	Frequency Stability Temperature & Voltage	< 2.5 ppm for Part 22	PASS	-
	§2.1055 §24.235 §27.54		Within Authorized Band		
4.4	§2.1053 §22.917(a) §24.238(a) §27.53(h)	Radiated Spurious Emission (Band 2) (Band 4) (Band 5) (Band 25) (Band 26) (Band 66)	< 43+10log ₁₀ (P[Watts])	PASS	Under limit 38.89 dB at 7494.00 MHz

Conformity Assessment Condition:

- The test results (PASS/FAIL) with all measurement uncertainty excluded are presented against the regulation limits or in accordance with the requirements stipulated by the applicant/manufacturer who shall bear all the risks of non-compliance that may potentially occur if measurement uncertainty is taken into account.
- The measurement uncertainty please refer to each test result in the section "Measurement Uncertainty"

Disclaimer:

The product specifications of the EUT presented in the test report that may affect the test assessments are declared by the manufacturer who shall take full responsibility for the authenticity.



1 General Description

1.1 Applicant

TCL Communication Ltd.

5/F, Building 22E, 22 Science Park East Avenue, Hong Kong Science Park, Shatin, NT, Hong Kong

1.2 Manufacturer

TCL Communication Ltd.

5/F, Building 22E, 22 Science Park East Avenue, Hong Kong Science Park, Shatin, NT, Hong Kong

1.3 Product Feature of Equipment Under Test

Product Feature	
Equipment	GSM/UMTS/LTE/NR Mobile phone
Brand Name	TCL
Model Name	T803E
FCC ID	2ACCJH183
IMEI Code/SN	Conducted: YTDMEIJZFYYTTOWK Radiation: 353318350121876/353318350121884
HW Version	05
SW Version	AGS7
EUT Stage	Identical Prototype



1.4 Product Specification of Equipment Under Test

Standards-related Product Specification	
Tx Frequency	LTE Band 2 : 1850 MHz ~ 1910 MHz LTE Band 4 : 1710 MHz ~ 1755 MHz LTE Band 5 : 824 MHz ~ 849 MHz LTE Band 25 : 1850 MHz ~ 1915 MHz LTE Band 26 : 824 MHz ~ 849 MHz LTE Band 66 : 1710 MHz ~ 1780 MHz
Rx Frequency	LTE Band 2 : 1930 MHz ~ 1990 MHz LTE Band 4 : 2110 MHz ~ 2155 MHz LTE Band 5 : 869 MHz ~ 894 MHz LTE Band 25 : 1930 MHz ~ 1995 MHz LTE Band 26 : 869 MHz ~ 894 MHz LTE Band 66 : 2110 MHz~ 2200 MHz
Bandwidth	LTE Band 2 : 1.4MHz / 3MHz / 5MHz / 10MHz / 15MHz / 20MHz LTE Band 4 : 1.4MHz / 3MHz / 5MHz / 10MHz / 15MHz / 20MHz LTE Band 5 : 1.4MHz / 3MHz / 5MHz / 10MHz LTE Band 25 : 1.4MHz / 3MHz / 5MHz / 10MHz / 15MHz / 20MHz LTE Band 26 : 1.4MHz / 3MHz / 5MHz / 10MHz / 15MHz LTE Band 66 : 1.4MHz / 3MHz / 5MHz / 10MHz / 15MHz / 20MHz
Maximum Output Power to Antenna	<Ant 0> LTE Band 5 : 24.05 dBm LTE Band 26 : 24.21 dBm <Ant 2> LTE Band 2 : 24.12 dBm LTE Band 4 : 23.15 dBm LTE Band 25 : 24.16 dBm LTE Band 66 : 23.19 dBm <Ant 1> LTE Band 4 : 23.51 dBm LTE Band 66 : 23.60 dBm
Antenna Gain	<Ant 0> LTE Band 5 : -4.3 dBi LTE Band 26 : -4.3 dBi <Ant 2> LTE Band 2 : -1.5 dBi LTE Band 4 : -1.6 dBi LTE Band 25 : -1.5 dBi LTE Band 66 : -1.6 dBi <Ant 1> LTE Band 4 : -3.4 dBi LTE Band 66 : -3.4 dBi
Type of Modulation	QPSK / 16QAM / 64QAM / 256QAM

Note:

1. The EIRP is calculated from Output power and antenna gain, so the maximum EIRP of LTE Band 4/66 for Antenna 2 is shown in the report.
2. For conducted test items, the whole testing has assessed Ant 1 for LTE Band 4/66 by referring to the higher conducted power



1.5 Modification of EUT

No modifications are made to the EUT during all test items.

1.6 Maximum ERP/EIRP Power and Emission Designator

LTE Band 2		QPSK		16QAM/64QAM/256QAM	
BW (MHz)	Frequency Range (MHz)	Maximum EIRP(W)	Emission Designator (99%OBW)	Maximum EIRP(W)	Emission Designator (99%OBW)
1.4	1850.7 ~ 1909.3	0.1778	1M09G7D	0.1517	1M10W7D
3	1851.5 ~ 1908.5	0.1791	2M72G7D	0.1503	2M73W7D
5	1852.5 ~ 1907.5	0.1786	4M51G7D	0.1531	4M47W7D
10	1855.0 ~ 1905.0	0.1795	9M01G7D	0.1507	9M05W7D
15	1857.5 ~ 1902.5	0.1799	13M5G7D	0.1521	13M4W7D
20	1860.0 ~ 1900.0	0.1828	17M9G7D	0.1552	17M8W7D
LTE Band 25		QPSK		16QAM/64QAM/256QAM	
BW (MHz)	Frequency Range (MHz)	Maximum EIRP(W)	Emission Designator (99%OBW)	Maximum EIRP(W)	Emission Designator (99%OBW)
1.4	1850.7 ~ 1914.3	0.1795	1M09G7D	0.1510	1M10W7D
3	1851.5 ~ 1913.5	0.1807	2M72G7D	0.1493	2M73W7D
5	1852.5 ~ 1912.5	0.1811	4M51G7D	0.1510	4M47W7D
10	1855.0 ~ 1910.0	0.1820	9M01G7D	0.1510	9M05W7D
15	1857.5 ~ 1907.5	0.1816	13M5G7D	0.1493	13M4W7D
20	1860.0 ~ 1905.0	0.1845	17M9G7D	0.1538	17M8W7D
LTE Band 4		QPSK		16QAM/64QAM/256QAM	
BW (MHz)	Frequency Range (MHz)	Maximum EIRP(W)	Emission Designator (99%OBW)	Maximum EIRP(W)	Emission Designator (99%OBW)
1.4	1710.7 ~ 1754.3	0.1409	1M09G7D	0.1117	1M09W7D
3	1711.5 ~ 1753.5	0.1396	2M72G7D	0.1186	2M72W7D
5	1712.5 ~ 1752.5	0.1409	4M48G7D	0.1194	4M50W7D
10	1715.0 ~ 1750.0	0.1406	9M09G7D	0.1208	9M03W7D
15	1717.5 ~ 1747.5	0.1393	13M5G7D	0.1199	13M5W7D
20	1720.0 ~ 1745.0	0.1429	17M9G7D	0.1230	17M9W7D



LTE Band 5		QPSK		16QAM/64QAM/256QAM	
BW (MHz)	Frequency Range (MHz)	Maximum ERP(W)	Emission Designator (99%OBW)	Maximum ERP(W)	Emission Designator (99%OBW)
1.4	824.7 ~ 848.3	0.0560	1M08G7D	0.0472	1M10W7D
3	825.5 ~ 847.5	0.0555	2M71G7D	0.0474	2M70W7D
5	826.5 ~ 846.5	0.0565	4M49G7D	0.0470	4M49W7D
10	829.0 ~ 844.0	0.0575	9M07G7D	0.0485	9M03W7D
LTE Band 26		QPSK		16QAM/64QAM/256QAM	
BW (MHz)	Frequency Range (MHz)	Maximum ERP(W)	Emission Designator (99%OBW)	Maximum ERP(W)	Emission Designator (99%OBW)
1.4	824.7 ~ 848.3	0.0571	1M08G7D	0.0475	1M10W7D
3	825.5 ~ 847.5	0.0562	2M71G7D	0.0469	2M70W7D
5	826.5 ~ 846.5	0.0569	4M49G7D	0.0461	4M49W7D
10	829.0 ~ 844.0	0.0577	9M07G7D	0.0479	9M03W7D
15	831.5 ~ 841.5	0.0597	13M5G7D	0.0478	13M6W7D
CH26790	824.0	0.0578	13M4G7D	0.0462	13M5W7D
LTE Band 66		QPSK		16QAM/64QAM/256QAM	
BW (MHz)	Frequency Range (MHz)	Maximum EIRP(W)	Emission Designator (99%OBW)	Maximum EIRP(W)	Emission Designator (99%OBW)
1.4	1710.7 ~ 1779.3	0.1371	1M09G7D	0.1130	1M09W7D
3	1711.5 ~ 1778.5	0.1396	2M72G7D	0.1205	2M72W7D
5	1712.5 ~ 1777.5	0.1422	4M48G7D	0.1197	4M50W7D
10	1715.0 ~ 1775.0	0.1416	9M09G7D	0.1216	9M03W7D
15	1717.5 ~ 1772.5	0.1403	13M5G7D	0.1213	13M5W7D
20	1720.0 ~ 1770.0	0.1442	17M9G7D	0.1242	17M9W7D

Note:

1. LTE Band 26 overlaps the entire frequency range of LTE Band 5. Therefore, the test results provided in this report covers Band 5 and the portion of Band 26 subject to Part 22.
2. LTE Band 66 overlaps the entire frequency range of LTE Band 4. Therefore, the test results provided in this report covers Band 66 as well as Band 4.
3. LTE Band 25 overlaps the entire frequency range of LTE Band 2. Therefore, the test results provided in this report covers Band 25 as well as Band 2.
4. All modulations have been tested, and only the worst test results of PSK & QAM are shown in the report.



1.7 Testing Location

Sporton International Inc. (ShenZhen) is accredited to ISO/IEC 17025:2017 by American Association for Laboratory Accreditation with Certificate Number 5145.01.

Test Firm	Sporton International Inc. (ShenZhen)		
Test Site Location	1/F, 2/F, Bldg 5, Shiling Industrial Zone, Xinwei Village, Xili, Nanshan, Shenzhen, 518055 People's Republic of China TEL: +86-755-86379589 FAX: +86-755-86379595		
Test Site No.	Sporton Site No.	FCC Designation No.	FCC Test Firm Registration No.
	TH01-SZ	CN1256	421272

Test Firm	Sporton International Inc. (ShenZhen)		
Test Site Location	101, 1st Floor, Block B, Building 1, No. 2, Tengfeng 4th Road, Fenghuang Community, Fuyong Street, Baoan District, Shenzhen City, Guangdong Province 518103 People's Republic of China TEL: +86-755-86066985		
Test Site No.	Sporton Site No.	FCC Designation No.	FCC Test Firm Registration No.
	03CH01-SZ	CN1256	421272

1.8 Test Software

Item	Site	Manufacture	Name	Version
1.	03CH01-SZ	AUDIX	E3	6.2009-8-24



1.9 Applicable Standards

According to the specifications of the manufacturer, the EUT must comply with the requirements of the following standards:

- ♦ 47 CFR Part 2, 22(H), 24(E), 27(L)
- ♦ ANSI C63.26-2015
- ♦ FCC KDB 971168 D01 Power Meas License Digital Systems v03r01
- ♦ FCC KDB 412172 D01 Determining ERP and EIRP v01r01

Remark:

1. All test items were verified and recorded according to the standards and without any deviation during the test.
2. This EUT has also been tested and complied with the requirements of FCC Part 15, Subpart B, recorded in a separate test report.



2 Test Configuration of Equipment Under Test

2.1 Test Mode

Antenna port conducted and radiated test items listed below are performed according to KDB 971168 D01 Power Meas License Digital Systems v03r01 with maximum output power.

Radiated measurements are performed by rotating the EUT in three different orthogonal test planes to find the maximum emission. (Y/Z Plane)

Test Items	Band	Bandwidth (MHz)						Modulation				RB #			Test Channel		
		1.4	3	5	10	15	20	QPSK	16 QAM	64 QAM	256 QAM	1	Half	Full	L	M	H
Max. Output Power	2	v	v	v	v	v	v	v	v	v	v	v	v	v	v	v	v
	4	v	v	v	v	v	v	v	v	v	v	v	v	v	v	v	v
	5	v	v	v	v	-	-	v	v	v	v	v	v	v	v	v	v
	25	v	v	v	v	v	v	v	v	v	v	v	v	v	v	v	v
	26	v	v	v	v	v	-	v	v	v	v	v	v	v	v	v	v
	66	v	v	v	v	v	v	v	v	v	v	v	v	v	v	v	v
Peak-to-Average Ratio	25						v	v	v	v				v		v	
	26					v	-	v	v	v				v		v	
	66						v	v	v	v				v		v	
26dB and 99% Bandwidth	25	v	v	v	v	v	v	v	v					v		v	
	26	v	v	v	v	v	-	v	v					v		v	
	66	v	v	v	v	v	v	v	v					v		v	
Conducted Band Edge	25	v	v	v	v	v	v	v	v	v		v		v	v	v	
	26	v	v	v	v	v	-	v	v	v		v		v	v	v	
	66	v	v	v	v	v	v	v	v	v		v		v	v	v	
Conducted Spurious Emission	25	v	v	v	v	v	v	v				v			v	v	
	26	v	v	v	v	v	-	v				v			v	v	
	66	v	v	v	v	v	v	v				v			v	v	
Frequency Stability	25				v			v						v		v	
	26				v		-	v						v		v	
	66				v			v						v		v	



Test Items	Band	Bandwidth (MHz)						Modulation				RB #			Test Channel			
		1.4	3	5	10	15	20	QPSK	16 QAM	64 QAM	256 QAM	1	Half	Full	L	M	H	
E.R.P / E.I.R.P	2	v	v	v	v	v	v	v	v	v	v	v	v	v	v	v	v	
	4	v	v	v	v	v	v	v	v	v	v	v	v	v	v	v	v	
	5	v	v	v	v	-	-	v	v	v	v	v	v	v	v	v	v	
	25	v	v	v	v	v	v	v	v	v	v	v	v	v	v	v	v	
	26	v	v	v	v	v	-	v	v	v	v	v	v	v	v	v	v	
	66	v	v	v	v	v	v	v	v	v	v	v	v	v	v	v	v	
Radiated Spurious Emission	25	Worst Case															v	
	26	Worst Case															v	
	66	Worst Case															v	
Note	1. The mark "v" means that this configuration is chosen for testing 2. The mark "-" means that this bandwidth is not supported. 3. The device is investigated from 30MHz to 10 times of fundamental signal for radiated spurious emission test under different RB size/offset and modulations in exploratory test. Subsequently, only the worst case emissions are reported. 4. For QAM modulation mode, the whole testing has assessed 16QAM&64QAM mode by referring to the higher conducted power.																	

2.2 Connection Diagram of Test System

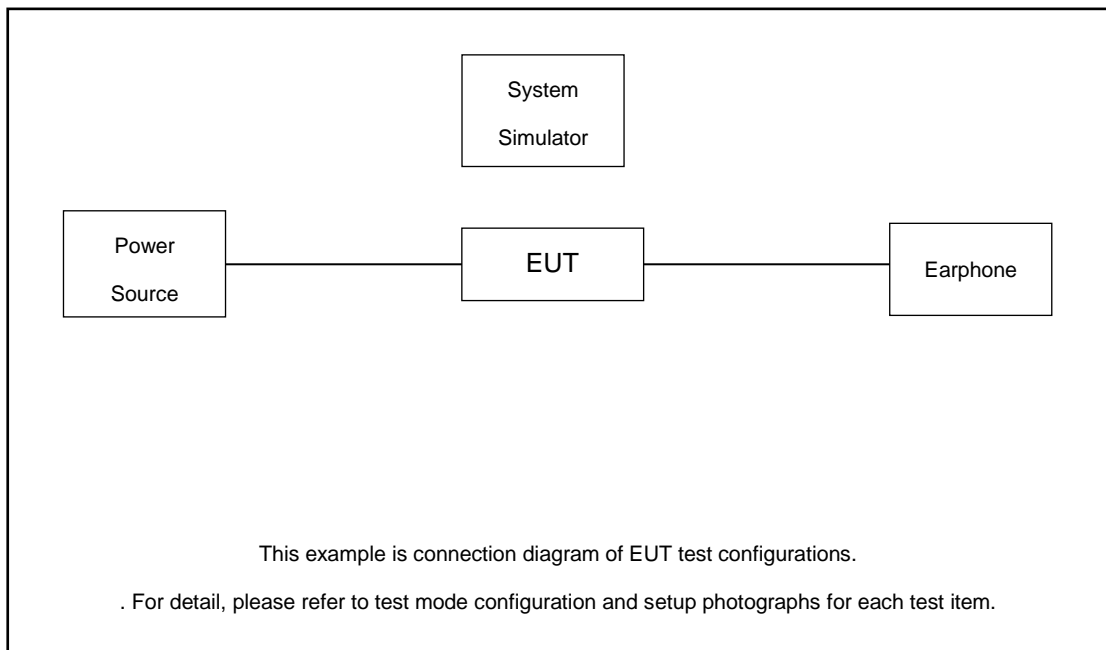



2.3 Support Unit used in test configuration and system

Item	Equipment	Trade Name	Model No.	FCC ID	Data Cable	Power Cord
1.	Power Supply	GWINSTEK	PSS-2002	N/A	N/A	Unshielded, 1.8 m
2.	LTE Base Station	Anritsu	MT8820C	N/A	N/A	Unshielded, 1.8 m
3.	Earphone	N/A	N/A	N/A	N/A	N/A

2.4 Measurement Results Explanation Example

For all conducted test items:

The offset level is set in the spectrum analyzer to compensate the RF cable loss and attenuator factor between EUT conducted output port and spectrum analyzer. With the offset compensation, the spectrum analyzer reading level is exactly the EUT RF output level.

The spectrum analyzer offset is derived from RF cable loss and attenuator factor.

$$\text{Offset} = \text{RF cable loss} + \text{attenuator factor}.$$

Following shows an offset computation example with cable loss 4.5 dB and 10dB attenuator.

Example :

$$\begin{aligned} \text{Offset}(dB) &= \text{RF cable loss}(dB) + \text{attenuator factor}(dB). \\ &= 4.5 + 10 = 14.5 \text{ (dB)} \end{aligned}$$



2.5 Frequency List of Low/Middle/High Channels

LTE Band 2 Channel and Frequency List				
BW [MHz]	Channel/Frequency(MHz)	Lowest	Middle	Highest
20	Channel	18700	18900	19100
	Frequency	1860	1880	1900
15	Channel	18675	18900	19125
	Frequency	1857.5	1880	1902.5
10	Channel	18650	18900	19150
	Frequency	1855	1880	1905
5	Channel	18625	18900	19175
	Frequency	1852.5	1880	1907.5
3	Channel	18615	18900	19185
	Frequency	1851.5	1880	1908.5
1.4	Channel	18607	18900	19193
	Frequency	1850.7	1880	1909.3

LTE Band 4 Channel and Frequency List				
BW [MHz]	Channel/Frequency(MHz)	Lowest	Middle	Highest
20	Channel	20050	20175	20300
	Frequency	1720	1732.5	1745
15	Channel	20025	20175	20325
	Frequency	1717.5	1732.5	1747.5
10	Channel	20000	20175	20350
	Frequency	1715	1732.5	1750
5	Channel	19975	20175	20375
	Frequency	1712.5	1732.5	1752.5
3	Channel	19965	20175	20385
	Frequency	1711.5	1732.5	1753.5
1.4	Channel	19957	20175	20393
	Frequency	1710.7	1732.5	1754.3



LTE Band 5 Channel and Frequency List				
BW [MHz]	Channel/Frequency(MHz)	Lowest	Middle	Highest
10	Channel	20450	20525	20600
	Frequency	829	836.5	844
5	Channel	20425	20525	20625
	Frequency	826.5	836.5	846.5
3	Channel	20415	20525	20635
	Frequency	825.5	836.5	847.5
1.4	Channel	20407	20525	20643
	Frequency	824.7	836.5	848.3

LTE Band 25 Channel and Frequency List				
BW [MHz]	Channel/Frequency(MHz)	Lowest	Middle	Highest
20	Channel	26140	26340	26590
	Frequency	1860	1880	1905
15	Channel	26115	26340	26615
	Frequency	1857.5	1880	1907.5
10	Channel	26090	26340	26640
	Frequency	1855	1880	1910
5	Channel	26065	26340	26665
	Frequency	1852.5	1880	1912.5
3	Channel	26055	26340	26675
	Frequency	1851.5	1880	1913.5
1.4	Channel	26047	26340	26683
	Frequency	1850.7	1880	1914.3



LTE Band 26 Channel and Frequency List				
BW [MHz]	Channel/Frequency(MHz)	Lowest	Middle	Highest
15	Channel	26865	26915	26965
	Frequency	831.5	836.5	841.5
10	Channel	26840	26915	26990
	Frequency	829	836.5	844
5	Channel	26815	26915	27015
	Frequency	826.5	836.5	846.5
3	Channel	26805	26915	27025
	Frequency	825.5	836.5	847.5
1.4	Channel	26797	26915	27033
	Frequency	824.7	836.5	848.3

LTE Band 66 Channel and Frequency List				
BW [MHz]	Channel/Frequency(MHz)	Lowest	Middle	Highest
20	Channel	132072	132322	132572
	Frequency	1720	1745	1770
15	Channel	132047	132322	132597
	Frequency	1717.5	1745	1772.5
10	Channel	132022	132322	132622
	Frequency	1715	1745	1775
5	Channel	131997	132322	132647
	Frequency	1712.5	1745	1777.5
3	Channel	131987	132322	132657
	Frequency	1711.5	1745	1778.5
1.4	Channel	131979	132322	132665
	Frequency	1710.7	1745	1779.3

3 Conducted Test Items

3.1 Measuring Instruments

See list of measuring instruments of this test report.

3.2 Test Setup

3.2.1 Conducted Output Power



3.2.2 Peak-to-Average Ratio, Occupied Bandwidth, Conducted Band-Edge and Conducted Spurious Emission



3.2.3 Frequency Stability

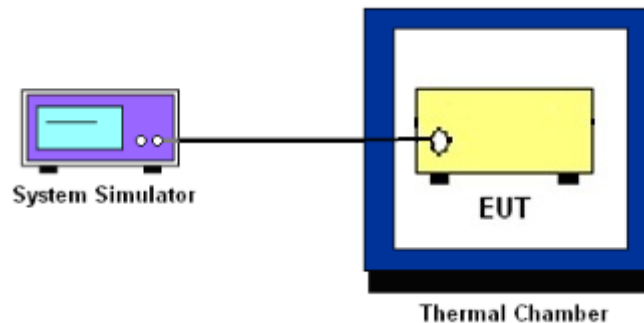

3.3 Test Result of Conducted Test

Please refer to Appendix A.



3.4 Conducted Output Power and ERP/EIRP

3.4.1 Description of the Conducted Output Power Measurement and ERP/EIRP Measurement

A system simulator was used to establish communication with the EUT. Its parameters were set to force the EUT transmitting at maximum output power. The measured power in the radio frequency on the transmitter output terminals shall be reported.

The ERP of mobile transmitters must not exceed 7 Watts for LTE Band 5 and Band 26.

The EIRP of mobile transmitters must not exceed 2 Watts for LTE Band 2 and Band 25.

The EIRP of mobile transmitters must not exceed 1 Watts for LTE Band 4 and Band 66.

According to KDB 412172 D01 Power Approach,

$EIRP = P_T + G_T - L_C$, $ERP = EIRP - 2.15$, where

P_T = transmitter output power in dBm

G_T = gain of the transmitting antenna in dBi

L_C = signal attenuation in the connecting cable between the transmitter and antenna in dB

3.4.2 Test Procedures

1. The testing follows ANSI C63.26 Section 5.2
2. The transmitter output port was connected to the system simulator.
3. Set EUT at maximum power through the system simulator.
4. Select lowest, middle, and highest channels for each band and different modulation.
5. Measure and record the power level from the system simulator.



3.5 Peak-to-Average Ratio

3.5.1 Description of the PAR Measurement

Power Complementary Cumulative Distribution Function (CCDF) curves provide a means for characterizing the power peaks of a digitally modulated signal on a statistical basis. A CCDF curve depicts the probability of the peak signal amplitude exceeding the average power level. Most contemporary measurement instrumentation include the capability to produce CCDF curves for an input signal provided that the instrument's resolution bandwidth can be set wide enough to accommodate the entire input signal bandwidth. In measuring transmissions in this band using an average power technique, the peak-to-average ratio (PAR) of the transmission may not exceed 13 dB.

3.5.2 Test Procedures

1. The testing follows ANSI C63.26 Section 5.2.3.4 (CCDF).
2. The EUT was connected to spectrum and system simulator via a power divider.
3. Set the CCDF (Complementary Cumulative Distribution Function) option in spectrum analyzer.
4. The highest RF powers were measured and recorded the maximum PAPR level associated with a probability of 0.1 %.
5. Record the deviation as Peak to Average Ratio.



3.6 Occupied Bandwidth

3.6.1 Description of Occupied Bandwidth Measurement

The occupied bandwidth is the width of a frequency band such that, below the lower and above the upper frequency limits, the mean powers emitted are each equal to a specified percentage 0.5% of the total mean transmitted power.

The 26 dB emission bandwidth is defined as the frequency range between two points, one above and one below the carrier frequency, at which the spectral density of the emission is attenuated 26 dB below the maximum in-band spectral density of the modulated signal. Spectral density (power per unit bandwidth) is to be measured with a detector of resolution bandwidth equal to approximately 1.0% of the emission bandwidth.

3.6.2 Test Procedures

1. The testing follows ANSI C63.26 Section 5.4
2. The EUT was connected to spectrum analyzer and system simulator via a power divider.
3. The spectrum analyzer center frequency is set to the nominal EUT channel center frequency. The span range for the spectrum analyzer shall be between two and five times the anticipated OBW.
4. The nominal resolution bandwidth (RBW) shall be in the range of 1 to 5 % of the anticipated OBW, and the VBW shall be at least 3 times the RBW.
5. Set the detection mode to peak, and the trace mode to max hold.
6. Determine the reference value: Set the EUT to transmit a modulated signal. Allow the trace to stabilize. Set the spectrum analyzer marker to the highest level of the displayed trace.
(this is the reference value)
7. Determine the “-26 dB down amplitude” as equal to (Reference Value – X).
8. Place two markers, one at the lowest and the other at the highest frequency of the envelope of the spectral display such that each marker is at or slightly below the “-X dB down amplitude” determined in step 6. If a marker is below this “-X dB down amplitude” value it shall be placed as close as possible to this value. The OBW is the positive frequency difference between the two markers.
9. Use the 99 % power bandwidth function of the spectrum analyzer and report the measured bandwidth.



3.7 Conducted Band Edge

3.7.1 Description of Conducted Band Edge Measurement

22.917(a)

For operations in the 824 – 849 MHz band, the FCC limit is $43 + 10\log_{10}(P[\text{Watts}])$ dB below the transmitter power $P(\text{Watts})$ in a 100kHz bandwidth. However, in the 1MHz bands immediately outside and adjacent to the licensee's frequency block, a resolution bandwidth of at least one percent of the emission bandwidth of the fundamental emission of the transmitter may be employed.

24.238 (a)

For operations in the 1850-1910 and 1930-1990 MHz band, the FCC limit is $43 + 10\log_{10}(P[\text{Watts}])$ dB below the transmitter power $P(\text{Watts})$ in a 1MHz bandwidth. However, in the 1 MHz bands immediately outside and adjacent to the frequency block a resolution bandwidth of at least one percent of the emission bandwidth of the fundamental emission of the transmitter may be employed.

27.53 (h)

For operations in the 1710 – 1755 MHz band, the FCC limit is $43 + 10\log_{10}(P[\text{Watts}])$ dB below the transmitter power $P(\text{Watts})$ in a 1 MHz bandwidth. However, in the 1MHz bands immediately outside and adjacent to the licensee's frequency block, a resolution bandwidth of at least one percent of the emission bandwidth of the fundamental emission of the transmitter may be employed.



3.7.2 Test Procedures

1. The testing follows ANSI C63.26 section 5.7
2. The EUT was connected to spectrum analyzer and system simulator via a power divider.
3. The band edges of low and high channels for the highest RF powers were measured.
4. Set RBW \geq 1% EBW in the 1MHz band immediately outside and adjacent to the band edge.
5. Beyond the 1 MHz band from the band edge, RBW=1MHz was used or a narrower RBW was used and the measured power was integrated over the full required measurement bandwidth of 1 MHz.
6. Set spectrum analyzer with RMS detector.
7. The RF fundamental frequency should be excluded against the limit line in the operating frequency band.
8. Checked that all the results comply with the emission limit line.

Example:

The limit line is derived from $43 + 10\log(P)$ dB below the transmitter power P(Watts)

$$= P(W) - [43 + 10\log(P)] \text{ (dB)}$$

$$= [30 + 10\log(P)] \text{ (dBm)} - [43 + 10\log(P)] \text{ (dB)} = -13\text{dBm}.$$

9. When using the integration method, the starting frequency of the integration shall be centered at one-half of the RBW away from the band edge.



3.8 Conducted Spurious Emission

3.8.1 Description of Conducted Spurious Emission Measurement

The power of any emission outside of the authorized operating frequency ranges must be lower than the transmitter power (P) by a factor of at least $43 + 10 \log (P)$ dB.

It is measured by means of a calibrated spectrum analyzer and scanned from 30 MHz up to a frequency including its 10th harmonic.

3.8.2 Test Procedures

1. The testing follows ANSI C63.26 section 5.7
2. The EUT was connected to spectrum analyzer and system simulator via a power divider.
3. The RF output of EUT was connected to the spectrum analyzer by RF cable and attenuator. The path loss was compensated to the results for each measurement.
4. The middle channel for the highest RF power within the transmitting frequency was measured.
5. The conducted spurious emission for the whole frequency range was taken.
6. Make the measurement with the spectrum analyzer's RBW = 1MHz, VBW = 3MHz.
7. Set spectrum analyzer with RMS detector.
8. Taking the record of maximum spurious emission.
9. The RF fundamental frequency should be excluded against the limit line in the operating frequency band.
10. The limit line is derived from $43 + 10\log(P)$ dB below the transmitter power P(Watts)
= P(W)- [43 + 10log(P)] (dB)
= [30 + 10log(P)] (dBm) - [43 + 10log(P)] (dB)
= -13dBm.



3.9 Frequency Stability

3.9.1 Description of Frequency Stability Measurement

The frequency stability shall be measured by variation of ambient temperature and variation of primary supply voltage to ensure that the fundamental emission stays within the authorized frequency block. The frequency stability of the transmitter shall be maintained within $\pm 0.00025\%$ ($\pm 2.5\text{ppm}$) of the center frequency.

3.9.2 Test Procedures for Temperature Variation

1. The testing follows ANSI C63.26 section 5.6.4
2. The EUT was set up in the thermal chamber and connected with the system simulator.
3. With power OFF, the temperature was decreased to -30°C and the EUT was stabilized before testing. Power was applied and the maximum change in frequency was recorded within one minute.
4. With power OFF, the temperature was raised in 10°C step up to 50°C . The EUT was stabilized at each step for at least half an hour. Power was applied and the maximum frequency change was recorded within one minute.

3.9.3 Test Procedures for Voltage Variation

1. The testing follows ANSI C63.26 section 5.6.5
2. The EUT was placed in a temperature chamber at $20\pm 5^{\circ}\text{C}$ and connected with the system simulator.
3. The power supply voltage to the EUT was varied from 85% to 115% of the nominal value for other than hand carried battery equipment.
4. For hand carried, battery powered equipment, reduce the primary ac or dc supply voltage to the battery operating end point, which shall be specified by the manufacturer.
5. The variation in frequency was measured for the worst case.

4 Radiated Test Items

4.1 Measuring Instruments

See list of measuring instruments of this test report.

4.2 Test Setup

4.2.1 For radiated test below 30MHz

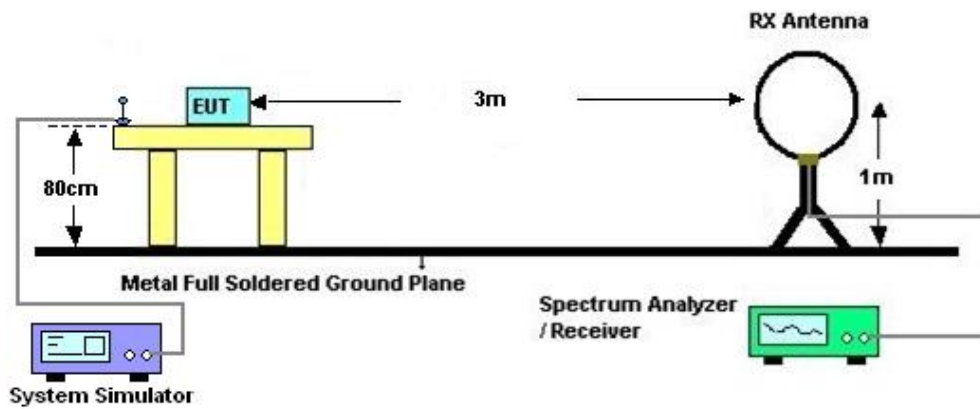

4.2.2 For radiated test from 30MHz to 1GHz

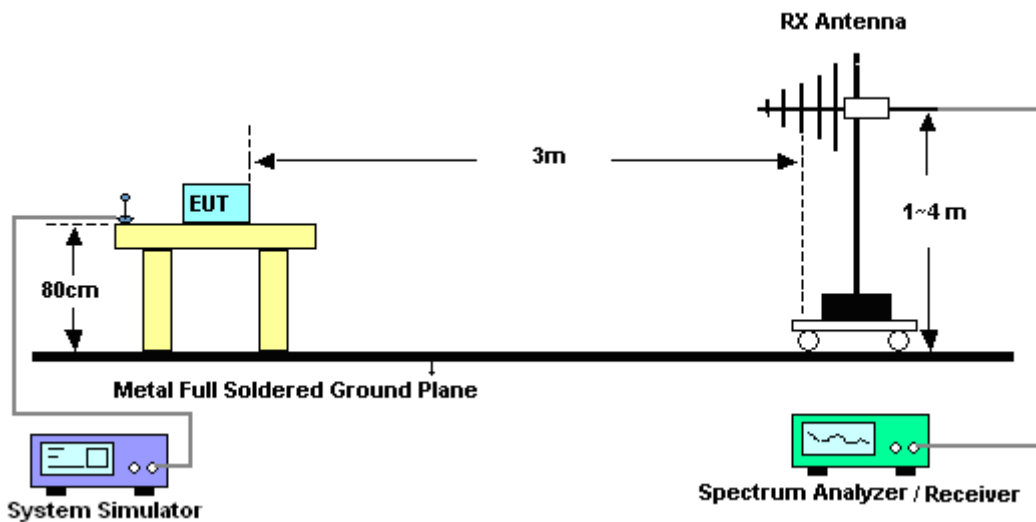

4.2.3 For radiated test above 1GHz

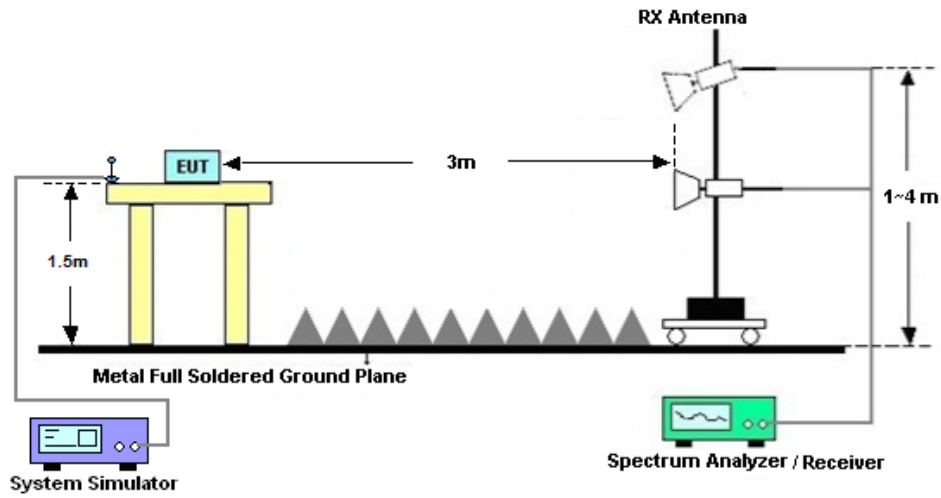

4.3 Test Result of Radiated Test

The low frequency, which started from 9 kHz to 30MHz, was pre-scanned and the result which was 20dB lower than the limit line was not reported.

Please refer to Appendix B.



4.4 Radiated Spurious Emission

4.4.1 Description of Radiated Spurious Emission

The radiated spurious emission was measured by substitution method according to ANSI C63.26. The power of any emission outside of the authorized operating frequency ranges must be attenuated below the transmitter power (P) by a factor of at least $43 + 10 \log (P)$ dB.

The spectrum is scanned from 30 MHz up to a frequency including its 10th harmonic.

4.4.2 Test Procedures

1. The testing follows ANSI C63.26 Section 5.5
2. The EUT was placed on a turntable with 0.8 meter height for frequency below 1GHz and 1.5 meter height for frequency above 1GHz respectively above ground.
3. The EUT was set 3 meters from the receiving antenna mounted on the antenna tower.
4. The table was rotated 360 degrees to determine the position of the highest spurious emission.
5. The height of the receiving antenna is varied between 1m to 4m to search the maximum spurious emission for both horizontal and vertical polarizations.
6. During the measurement, the system simulator parameters were set to force the EUT transmitting at maximum output power.
7. Make the measurement with the spectrum analyzer's RBW = 1MHz, VBW = 3MHz, taking the record of maximum spurious emission.
8. A horn antenna was substituted in place of the EUT and was driven by a signal generator.
9. Tune the output power of signal generator to the same emission level with EUT maximum spurious emission.
10. $EIRP \text{ (dBm)} = S.G. \text{ Power} - Tx \text{ Cable Loss} + Tx \text{ Antenna Gain}$
11. $ERP \text{ (dBm)} = EIRP - 2.15$
12. The RF fundamental frequency should be excluded against the limit line in the operating frequency band.

The limit line is derived from $43 + 10\log(P)$ dB below the transmitter power P(Watts)
= $P(W) - [43 + 10\log(P)] \text{ (dB)}$
= $[30 + 10\log(P)] \text{ (dBm)} - [43 + 10\log(P)] \text{ (dB)}$
= -13dBm.



5 List of Measuring Equipment

Instrument	Manufacturer	Model No.	Serial No.	Characteristics	Calibration Date	Test Date	Due Date	Remark
Spectrum Analyzer	R&S	FSV40	101078	10Hz~40GHz	Apr. 06, 2023	Mar. 14, 2024~ Mar. 21, 2024	Apr. 05, 2024	Conducted (TH01-SZ)
DC Power Supply	TTI	PL330P	290070	Max 32V , 3A	Oct. 16, 2023	Mar. 14, 2024~ Mar. 21, 2024	Oct. 15, 2024	Conducted (TH01-SZ)
Power Divider	TOJOIN	PS-2SM-04 265	60.06.020.007 7	0.4GHz~26.5GHz	Dec. 25, 2023	Mar. 14, 2024~ Mar. 21, 2024	Dec. 24, 2024	Conducted (TH01-SZ)
Thermal Chamber	Ten Billion Hongzhangroup	LP-150U	H2014081803	-40~+150°C	Jul. 05, 2023	Mar. 14, 2024~ Mar. 21, 2024	Jul. 04, 2024	Conducted (TH01-SZ)
EMI Test Receiver&SA	Agilent	N9038A	MY52260185	20Hz~26.5GHz	Dec. 27, 2023	Mar. 23, 2024~ Mar. 24, 2024	Dec. 26, 2024	Radiation (03CH01-SZ)
Loop Antenna	R&S	HFH2-Z2	100354	9kHz~30MHz	Jul. 28, 2022	Mar. 23, 2024~ Mar. 24, 2024	Jul. 27, 2024	Radiation (03CH01-SZ)
HF Amplifier	KEYSIGHT	83017A	MY53270105	0.5GHz~26.5Ghz	Oct. 18,2023	Mar. 23, 2024~ Mar. 24, 2024	Oct. 17,2024	Radiation (03CH01-SZ)
Bilog Antenna	TeseQ	CBL6112D	35407	30MHz-2GHz	Oct. 24, 2023	Mar. 23, 2024~ Mar. 24, 2024	Oct. 23, 2025	Radiation (03CH01-SZ)
Double Ridge Horn Antenna	ETS-Lindgren	3117	00119436	1GHz~18GHz	Jul. 08, 2023	Mar. 23, 2024~ Mar. 24, 2024	Jul. 07, 2024	Radiation (03CH01-SZ)
SHF-EHF Horn	com-power	AH-840	101071	18Ghz-40GHz	Apr. 08,2023	Mar. 23, 2024~ Mar. 24, 2024	Apr. 07,2024	Radiation (03CH01-SZ)
LF Amplifier	Burgeon	BPA-530	102209	0.01~3000Mhz	Apr. 04, 2023	Mar. 23, 2024~ Mar. 24, 2024	Apr. 03, 2024	Radiation (03CH01-SZ)
HF Amplifier	MITEQ	AMF-7D-00 101800-30-1 0P-R	1943528	1GHz~18GHz	Oct. 18,2023	Mar. 23, 2024~ Mar. 24, 2024	Oct. 17,2024	Radiation (03CH01-SZ)
HF Amplifier	MITEQ	TTA1840-35 -HG	1871923	18GHz~40GHz	Jul. 07, 2023	Mar. 23, 2024~ Mar. 24, 2024	Jul. 06, 2024	Radiation (03CH01-SZ)
AC Power Source	Chroma	61601	616010001985	N/A	Oct. 18,2023	Mar. 23, 2024~ Mar. 24, 2024	Oct. 17,2024	Radiation (03CH01-SZ)
Turn Table	EM	EM1000	N/A	0~360 degree	NCR	Mar. 23, 2024~ Mar. 24, 2024	NCR	Radiation (03CH01-SZ)
Antenna Mast	EM	EM1000	N/A	1 m~4 m	NCR	Mar. 23, 2024~ Mar. 24, 2024	NCR	Radiation (03CH01-SZ)

NCR: No Calibration Required



6 Measurement Uncertainty

The measurement uncertainties shown below were calculated in accordance with the requirements of ANSI 63.26-2015. All the measurement uncertainty value were shown with a coverage K=2 to indicate 95% level of confidence. The measurement data show herein meets or exceeds the CISPR measurement uncertainty values specified in CISPR 16-4-2 and can be compared directly to specified limit to determine compliance.

Uncertainty of Conducted Measurement

Test Item	Uncertainty
Conducted Spurious Emission & Bandedge	±1.34 dB
Occupied Channel Bandwidth	±0.012 MHz
Conducted Power	±1.34 dB
Peak to Average Ratio	±1.34 dB
Frequency Stability	±1.3 ppm

Uncertainty of Radiated Emission Measurement (30 MHz ~ 1000 MHz)

Measuring Uncertainty for a Level of Confidence of 95% (U = 2Uc(y))	2.48 dB
---	---------

Uncertainty of Radiated Emission Measurement (1 GHz ~ 18 GHz)

Measuring Uncertainty for a Level of Confidence of 95% (U = 2Uc(y))	3.53 dB
---	---------

Uncertainty of Radiated Emission Measurement (18 GHz ~ 40 GHz)

Measuring Uncertainty for a Level of Confidence of 95% (U = 2Uc(y))	4.02 dB
---	---------

----- THE END -----



Appendix A. Test Results of Conducted Test

Test Engineer :	Lorenzo Liu	Temperature :	24~26°C
		Relative Humidity :	50~53%

Conducted Output Power(Average power) and ERP/EIRP

LTE Band 2_ANT 2:

BW [MHz]	Modulation	RB Size	RB Offset	Power Low Ch. / Freq.	Power Middle Ch. / Freq.	Power High Ch. / Freq.	EIRP(W)		
Channel				18700	18900	19100			
Frequency (MHz)				1860	1880	1900	L	M	H
20	QPSK	1	0	24.11	24.12	24.10	0.1824	0.1828	0.1820
20	QPSK	1	49	24.10	24.10	24.09	0.1820	0.1820	0.1816
20	QPSK	1	99	23.95	24.01	24.00	0.1758	0.1782	0.1778
20	QPSK	50	0	23.11	23.12	23.11	0.1449	0.1452	0.1449
20	QPSK	50	24	23.10	23.07	23.10	0.1445	0.1435	0.1445
20	QPSK	50	50	23.10	23.03	23.05	0.1445	0.1422	0.1429
20	QPSK	100	0	23.10	23.11	23.08	0.1445	0.1449	0.1439
20	16QAM	1	0	23.31	23.41	23.34	0.1517	0.1552	0.1528
20	64QAM	1	0	22.24	22.26	22.27	0.1186	0.1191	0.1194
20	256QAM	1	0	19.06	19.00	19.05	0.0570	0.0562	0.0569
Channel				18675	18900	19125	EIRP(W)		
Frequency (MHz)				1857.5	1880	1902.5	L	M	H
15	QPSK	1	0	24.04	24.05	24.02	0.1795	0.1799	0.1786
15	16QAM	1	0	23.19	23.32	23.16	0.1476	0.1521	0.1466
Channel				18650	18900	19150	EIRP(W)		
Frequency (MHz)				1855	1880	1905	L	M	H
10	QPSK	1	0	23.93	24.04	23.91	0.1750	0.1795	0.1742
10	16QAM	1	0	23.23	23.28	23.27	0.1489	0.1507	0.1503
Channel				18625	18900	19175	EIRP(W)		
Frequency (MHz)				1852.5	1880	1907.5	L	M	H
5	QPSK	1	0	24.02	23.95	23.95	0.1786	0.1758	0.1758
5	16QAM	1	0	23.23	23.35	23.25	0.1489	0.1531	0.1496
Channel				18615	18900	19185	EIRP(W)		
Frequency (MHz)				1851.5	1880	1908.5	L	M	H
3	QPSK	1	0	24.03	23.95	23.94	0.1791	0.1758	0.1754
3	16QAM	1	0	23.17	23.27	23.17	0.1469	0.1503	0.1469
Channel				18607	18900	19193	EIRP(W)		
Frequency (MHz)				1850.7	1880	1909.3	L	M	H
1.4	QPSK	1	0	23.98	24.00	23.91	0.1770	0.1778	0.1742
1.4	16QAM	1	0	23.17	23.31	23.20	0.1469	0.1517	0.1479



LTE Band 4_ANT 2:

BW [MHz]	Modulation	RB Size	RB Offset	Power Low Ch. / Freq.	Power Middle Ch. / Freq.	Power High Ch. / Freq.	EIRP(W)		
Channel				20050	20175	20300			
Frequency (MHz)				1720	1732.5	1745	L	M	H
20	QPSK	1	0	23.13	23.15	23.11	0.1422	0.1429	0.1416
20	QPSK	1	49	23.11	23.11	23.14	0.1416	0.1416	0.1426
20	QPSK	1	99	23.03	23.02	23.09	0.1390	0.1387	0.1409
20	QPSK	50	0	22.11	22.19	22.18	0.1125	0.1146	0.1143
20	QPSK	50	24	22.10	22.14	22.17	0.1122	0.1132	0.1140
20	QPSK	50	50	22.06	22.10	22.17	0.1112	0.1122	0.1140
20	QPSK	100	0	22.08	22.15	22.14	0.1117	0.1135	0.1132
20	16QAM	1	0	22.43	22.39	22.50	0.1211	0.1199	0.1230
20	64QAM	1	0	21.29	21.31	21.27	0.0931	0.0935	0.0927
20	256QAM	1	0	18.17	18.26	18.19	0.0454	0.0463	0.0456
Channel				20025	20175	20325	EIRP(W)		
Frequency (MHz)				1717.5	1732.5	1747.5	L	M	H
15	QPSK	1	0	23.03	23.04	22.99	0.1390	0.1393	0.1377
15	16QAM	1	0	22.39	22.34	22.37	0.1199	0.1186	0.1194
Channel				20000	20175	20350	EIRP(W)		
Frequency (MHz)				1715	1732.5	1750	L	M	H
10	QPSK	1	0	23.05	23.08	23.07	0.1396	0.1406	0.1403
10	16QAM	1	0	22.32	22.25	22.42	0.1180	0.1161	0.1208
Channel				19975	20175	20375	EIRP(W)		
Frequency (MHz)				1712.5	1732.5	1752.5	L	M	H
5	QPSK	1	0	23.03	23.09	23.01	0.1390	0.1409	0.1384
5	16QAM	1	0	22.34	22.25	22.37	0.1186	0.1161	0.1194
Channel				19965	20175	20385	EIRP(W)		
Frequency (MHz)				1711.5	1732.5	1753.5	L	M	H
3	QPSK	1	0	23.05	23.03	22.98	0.1396	0.1390	0.1374
3	16QAM	1	0	22.30	22.28	22.34	0.1175	0.1169	0.1186
Channel				19950	20175	20393	EIRP(W)		
Frequency (MHz)				1710	1732.5	1754.3	L	M	H
1.4	QPSK	1	0	23.09	23.03	23.02	0.1409	0.1390	0.1387
1.4	16QAM	1	0	21.99	21.93	22.08	0.1094	0.1079	0.1117



LTE Band 5_ANT 0:

BW [MHz]	Modulation	RB Size	RB Offset	Power Low Ch. / Freq.	Power Middle Ch. / Freq.	Power High Ch. / Freq.	ERP(W)		
Channel				20450	20525	20600			
Frequency (MHz)				829	836.5	844	L	M	H
10	QPSK	1	0	23.98	24.05	24.03	0.0566	0.0575	0.0573
10	QPSK	1	25	23.92	23.94	24.01	0.0558	0.0561	0.0570
10	QPSK	1	49	23.93	24.01	24.00	0.0560	0.0570	0.0569
10	QPSK	25	0	22.92	23.05	23.03	0.0444	0.0457	0.0455
10	QPSK	25	12	22.89	22.96	22.92	0.0441	0.0448	0.0444
10	QPSK	25	25	22.88	22.88	23.02	0.0440	0.0440	0.0454
10	QPSK	50	0	22.90	23.05	23.01	0.0442	0.0457	0.0453
10	16QAM	1	0	23.09	23.31	23.24	0.0461	0.0485	0.0478
10	64QAM	1	0	22.07	22.13	22.09	0.0365	0.0370	0.0366
10	256QAM	1	0	18.68	18.84	18.70	0.0167	0.0173	0.0168
Channel				20425	20525	20625	ERP(W)		
Frequency (MHz)				826.5	836.5	846.5	L	M	H
5	QPSK	1	0	23.83	23.88	23.97	0.0547	0.0553	0.0565
5	16QAM	1	0	22.97	23.17	23.11	0.0449	0.0470	0.0463
Channel				20415	20525	20635	ERP(W)		
Frequency (MHz)				825.5	836.5	847.5	L	M	H
3	QPSK	1	0	23.79	23.89	23.88	0.0542	0.0555	0.0553
3	16QAM	1	0	22.94	23.21	23.18	0.0446	0.0474	0.0471
Channel				20407	20525	20643	ERP(W)		
Frequency (MHz)				824.7	836.5	848.3	L	M	H
1.4	QPSK	1	0	23.91	23.90	23.93	0.0557	0.0556	0.0560
1.4	16QAM	1	0	23.02	23.19	23.18	0.0454	0.0472	0.0471



LTE Band 25_ANT 2:

BW [MHz]	Modulation	RB Size	RB Offset	Power Low Ch. / Freq.	Power Middle Ch. / Freq.	Power High Ch. / Freq.	EIRP(W)		
Channel				26140	26340	26590			
Frequency (MHz)				1860	1880	1905	L	M	H
20	QPSK	1	0	24.07	24.16	24.15	0.1807	0.1845	0.1841
20	QPSK	1	49	24.03	24.09	24.13	0.1791	0.1816	0.1832
20	QPSK	1	99	24.02	23.99	24.05	0.1786	0.1774	0.1799
20	QPSK	50	0	23.12	23.14	23.13	0.1452	0.1459	0.1455
20	QPSK	50	24	23.09	23.12	23.10	0.1442	0.1452	0.1445
20	QPSK	50	50	23.11	23.05	23.09	0.1449	0.1429	0.1442
20	QPSK	100	0	23.08	23.11	23.10	0.1439	0.1449	0.1445
20	16QAM	1	0	23.35	23.32	23.37	0.1531	0.1521	0.1538
20	64QAM	1	0	22.26	22.24	22.34	0.1191	0.1186	0.1213
20	256QAM	1	0	18.82	18.74	18.77	0.0540	0.0530	0.0533
Channel				26115	26340	26615	EIRP(W)		
Frequency (MHz)				1857.5	1880	1907.5	L	M	H
15	QPSK	1	0	23.93	24.09	23.96	0.1750	0.1816	0.1762
15	16QAM	1	0	23.24	23.24	23.18	0.1493	0.1493	0.1472
Channel				26090	26340	26640	EIRP(W)		
Frequency (MHz)				1855	1880	1910	L	M	H
10	QPSK	1	0	23.92	24.10	24.08	0.1746	0.1820	0.1811
10	16QAM	1	0	23.28	23.19	23.29	0.1507	0.1476	0.1510
Channel				26065	26340	26665	EIRP(W)		
Frequency (MHz)				1852.5	1880	1912.5	L	M	H
5	QPSK	1	0	23.91	23.97	24.08	0.1742	0.1766	0.1811
5	16QAM	1	0	23.29	23.14	23.28	0.1510	0.1459	0.1507
Channel				26055	26340	26675	EIRP(W)		
Frequency (MHz)				1851.5	1880	1913.5	L	M	H
3	QPSK	1	0	23.93	24.07	24.01	0.1750	0.1807	0.1782
3	16QAM	1	0	23.16	23.15	23.24	0.1466	0.1462	0.1493
Channel				26047	26340	26683	EIRP(W)		
Frequency (MHz)				1850.7	1880	1914.3	L	M	H
1.4	QPSK	1	0	23.89	24.04	23.97	0.1734	0.1795	0.1766
1.4	16QAM	1	0	23.24	23.25	23.29	0.1493	0.1496	0.1510



LTE Band 26_ANT 0:

BW [MHz]	Modulation	RB Size	RB Offset	Power Low Ch. / Freq.	Power Low Ch. / Freq.	Power Middle Ch. / Freq.	Power High Ch. / Freq.	ERP(W)			
Channel				26790	26865	26915	26965				
Frequency (MHz)				824	831.5	836.5	841.5	Straddle Ch	L	M	H
15	QPSK	1	0	24.07	24.13	24.21	24.20	0.0578	0.0586	0.0597	0.0596
15	QPSK	1	37	23.99	24.11	24.17	24.01	0.0568	0.0583	0.0592	0.0570
15	QPSK	1	74	24.05	24.02	24.02	24.08	0.0575	0.0571	0.0571	0.0579
15	QPSK	36	0	22.89	23.00	23.05	23.00	0.0441	0.0452	0.0457	0.0452
15	QPSK	36	20	22.90	22.91	23.00	22.99	0.0442	0.0443	0.0452	0.0451
15	QPSK	36	39	22.86	22.98	23.00	22.96	0.0438	0.0450	0.0452	0.0448
15	QPSK	75	0	22.96	23.01	23.04	22.98	0.0448	0.0453	0.0456	0.0450
15	16QAM	1	0	23.10	23.08	23.24	23.16	0.0462	0.0460	0.0478	0.0469
15	64QAM	1	0	22.11	22.06	22.19	22.20	0.0368	0.0364	0.0375	0.0376
15	256QAM	1	0	18.62	18.80	18.76	18.77	0.0165	0.0172	0.0170	0.0171
Channel					26840	26915	26990	ERP(W)			
Frequency (MHz)					829	836.5	844		L	M	H
10	QPSK	1	0		23.97	24.02	24.06		0.0565	0.0571	0.0577
10	16QAM	1	0		23.07	23.25	23.22		0.0459	0.0479	0.0475
Channel					26815	26915	27015	ERP(W)			
Frequency (MHz)					826.5	836.5	846.5		L	M	H
5	QPSK	1	0		23.87	23.91	24.00		0.0552	0.0557	0.0569
5	16QAM	1	0		22.99	23.09	23.03		0.0451	0.0461	0.0455
Channel					26815	26915	27025	ERP(W)			
Frequency (MHz)					825.5	836.5	847.5		L	M	H
3	QPSK	1	0		23.87	23.95	23.88		0.0552	0.0562	0.0553
3	16QAM	1	0		22.89	23.16	23.03		0.0441	0.0469	0.0455
Channel					26797	26915	27033	ERP(W)			
Frequency (MHz)					824.7	836.5	848.3		L	M	H
1.4	QPSK	1	0		23.92	24.02	24.02		0.0558	0.0571	0.0571
1.4	16QAM	1	0		23.07	23.18	23.22		0.0459	0.0471	0.0475



LTE Band 66_ANT 2:

BW [MHz]	Modulation	RB Size	RB Offset	Power Low Ch. / Freq.	Power Middle Ch. / Freq.	Power High Ch. / Freq.	EIRP(W)		
Channel				132072	132322	132572	EIRP(W)		
Frequency (MHz)				1720	1745	1770	L	M	H
20	QPSK	1	0	23.13	23.19	23.15	0.1422	0.1442	0.1429
20	QPSK	1	49	23.05	23.18	23.10	0.1396	0.1439	0.1413
20	QPSK	1	99	22.91	23.02	23.00	0.1352	0.1387	0.1380
20	QPSK	50	0	22.09	22.26	22.15	0.1119	0.1164	0.1135
20	QPSK	50	24	22.08	22.24	22.11	0.1117	0.1159	0.1125
20	QPSK	50	50	22.04	22.15	22.12	0.1107	0.1135	0.1127
20	QPSK	100	0	22.05	22.19	22.09	0.1109	0.1146	0.1119
20	16QAM	1	0	22.47	22.54	22.39	0.1222	0.1242	0.1199
20	64QAM	1	0	21.41	21.47	21.26	0.0957	0.0971	0.0925
20	256QAM	1	0	18.21	18.29	18.17	0.0458	0.0467	0.0454
Channel				132047	132322	132597	EIRP(W)		
Frequency (MHz)				1717.5	1745	1772.5	L	M	H
15	QPSK	1	0	23.01	23.07	23.00	0.1384	0.1403	0.1380
15	16QAM	1	0	22.33	22.44	22.28	0.1183	0.1213	0.1169
Channel				132022	132322	132622	EIRP(W)		
Frequency (MHz)				1715	1745	1775	L	M	H
10	QPSK	1	0	23.01	23.08	23.11	0.1384	0.1406	0.1416
10	16QAM	1	0	22.31	22.45	22.29	0.1178	0.1216	0.1172
Channel				131997	132322	132647	EIRP(W)		
Frequency (MHz)				1712.5	1745	1777.5	L	M	H
5	QPSK	1	0	23.04	23.13	23.03	0.1393	0.1422	0.1390
5	16QAM	1	0	22.38	22.38	22.26	0.1197	0.1197	0.1164
Channel				131987	132322	132657	EIRP(W)		
Frequency (MHz)				1711.5	1745	1778.5	L	M	H
3	QPSK	1	0	23.05	23.03	23.05	0.1396	0.1390	0.1396
3	16QAM	1	0	22.41	22.38	22.24	0.1205	0.1197	0.1159
Channel				131979	132322	132665	EIRP(W)		
Frequency (MHz)				1710.7	1745	1779.3	L	M	H
1.4	QPSK	1	0	22.97	22.92	22.92	0.1371	0.1355	0.1355
1.4	16QAM	1	0	21.89	22.13	21.91	0.1069	0.1130	0.1074



LTE Band 25

Peak-to-Average Ratio

Mode	LTE Band 25 / 20MHz			
Mod.	QPSK	16QAM	64QAM	Limit: 13dB
RB Size	Full RB	Full RB	Full RB	Result
Middle CH	4.84	5.86	6.17	PASS



LTE Band 25 / 20MHz / QPSK

Middle Channel / Full RB

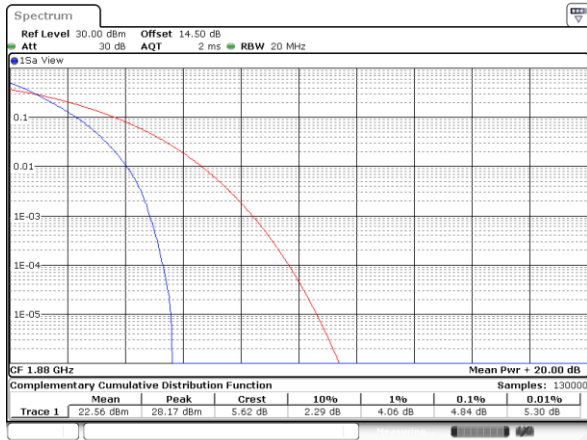

Date: 15.MAR.2024 00:23:02

LTE Band 25 / 20MHz / 16QAM

Middle Channel / Full RB

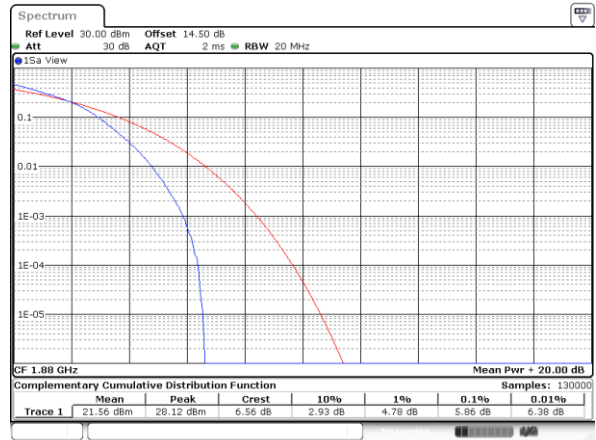

Date: 15.MAR.2024 00:23:31

LTE Band 25 / 20MHz / 64QAM

Middle Channel / Full RB

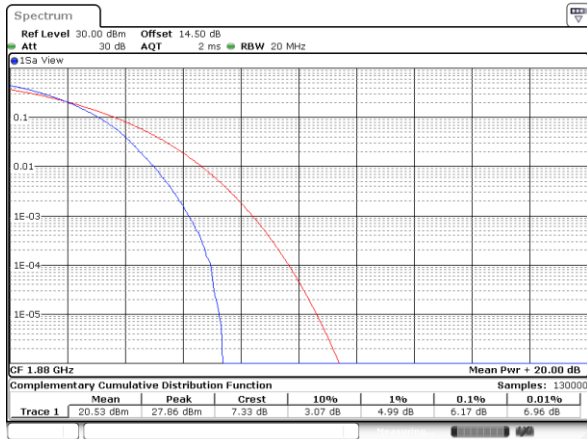

Date: 15.MAR.2024 00:23:59



26dB Bandwidth

Mode	LTE Band 25 : 26dB BW(MHz)											
	1.4MHz		3MHz		5MHz		10MHz		15MHz		20MHz	
Mod.	QPSK	16QAM	QPSK	16QAM	QPSK	16QAM	QPSK	16QAM	QPSK	16QAM	QPSK	16QAM
Middle CH	1.29	1.29	2.99	2.96	4.82	4.90	9.77	9.85	14.33	14.45	19.06	18.86



LTE Band 25

Middle Channel / 1.4MHz / QPSK

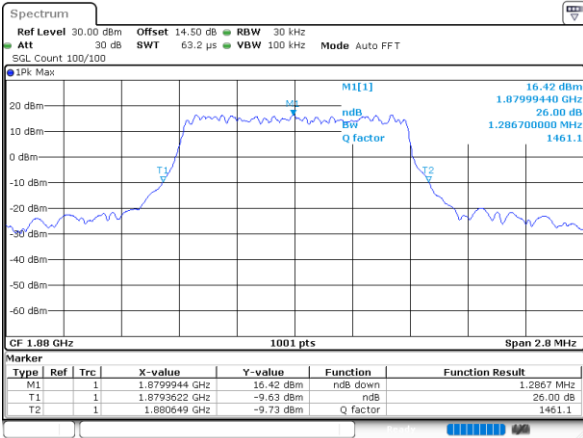

Date: 14.MAR.2024 22:32:20

Middle Channel / 1.4MHz / 16QAM

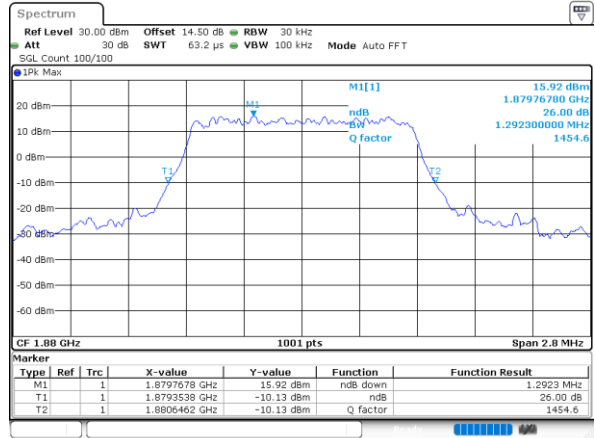

Date: 14.MAR.2024 22:33:01

Middle Channel / 3MHz / QPSK

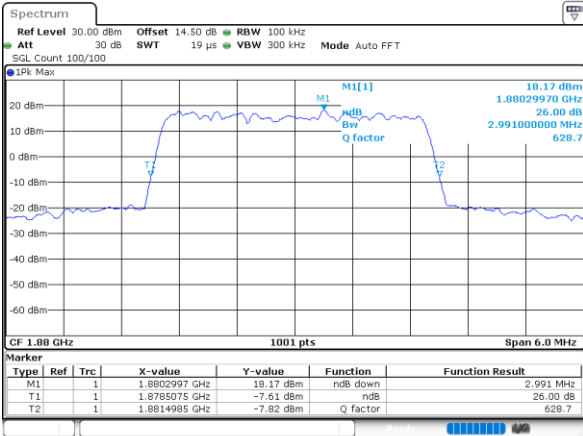

Date: 14.MAR.2024 22:51:27

Middle Channel / 3MHz / 16QAM

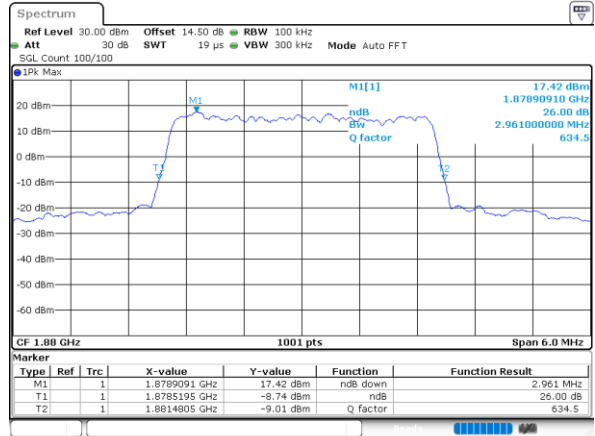

Date: 14.MAR.2024 22:52:08

Middle Channel / 5MHz / QPSK

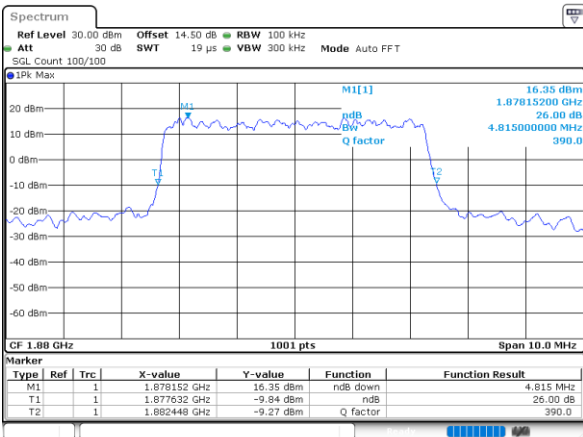

Date: 14.MAR.2024 23:22:43

Middle Channel / 5MHz / 16QAM

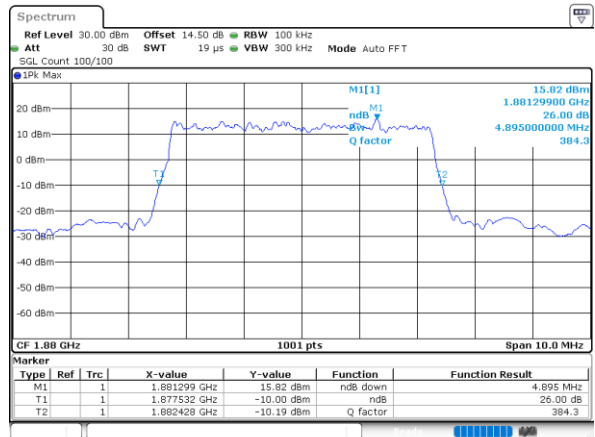

Date: 14.MAR.2024 23:23:24



LTE Band 25

Middle Channel / 10MHz / QPSK

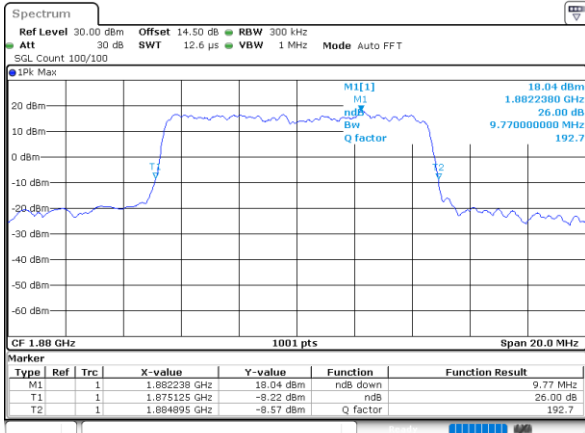

Date: 14_MAR_2024 23:41:52

Middle Channel / 10MHz / 16QAM

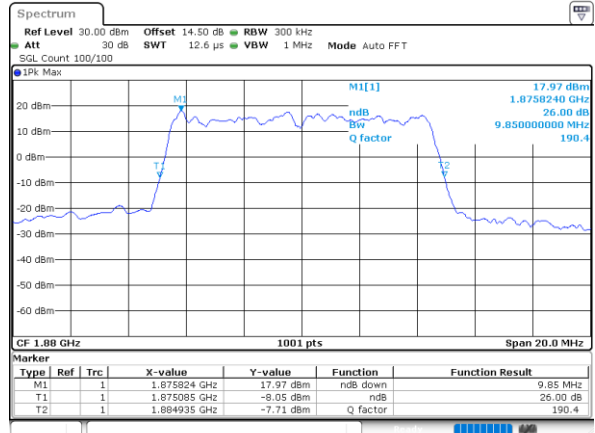

Date: 14_MAR_2024 23:42:33

Middle Channel / 15MHz / QPSK

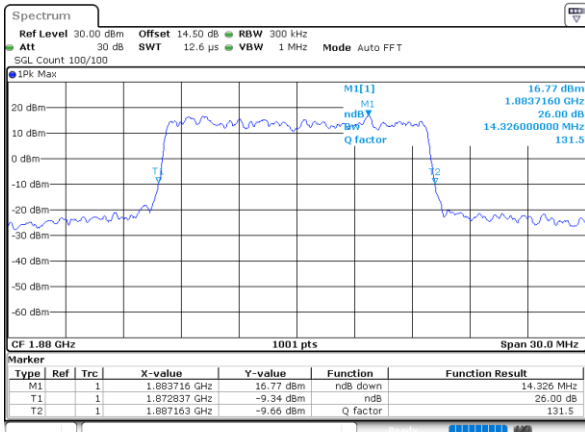

Date: 15_MAR_2024 00:03:53

Middle Channel / 15MHz / 16QAM

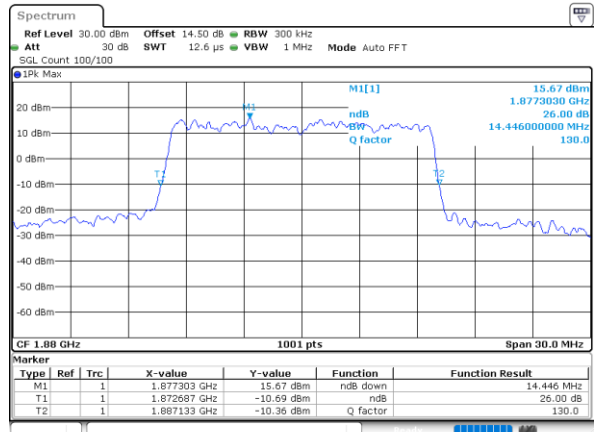

Date: 15_MAR_2024 00:04:34

Middle Channel / 20MHz / QPSK

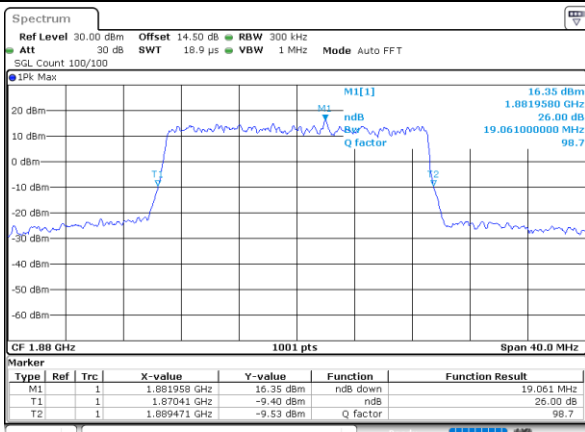

Date: 15_MAR_2024 00:21:54

Middle Channel / 20MHz / 16QAM

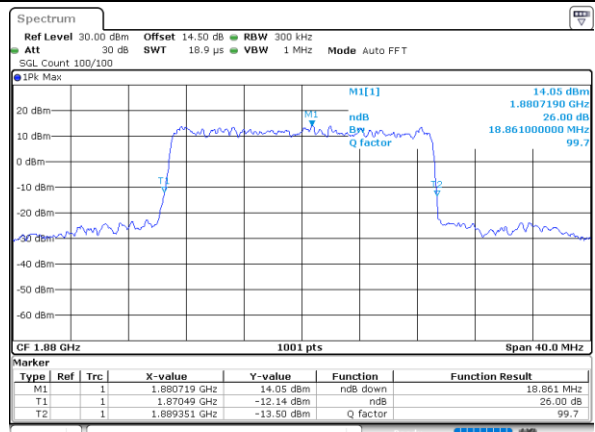

Date: 15_MAR_2024 00:22:34



Occupied Bandwidth

Mode	LTE Band 25 : 99%OBW(MHz)											
	1.4MHz		3MHz		5MHz		10MHz		15MHz		20MHz	
Mod.	QPSK	16QAM	QPSK	16QAM	QPSK	16QAM	QPSK	16QAM	QPSK	16QAM	QPSK	16QAM
Middle CH	1.09	1.10	2.72	2.73	4.51	4.47	9.01	9.05	13.46	13.37	17.94	17.82



LTE Band 25

Middle Channel / 1.4MHz / QPSK

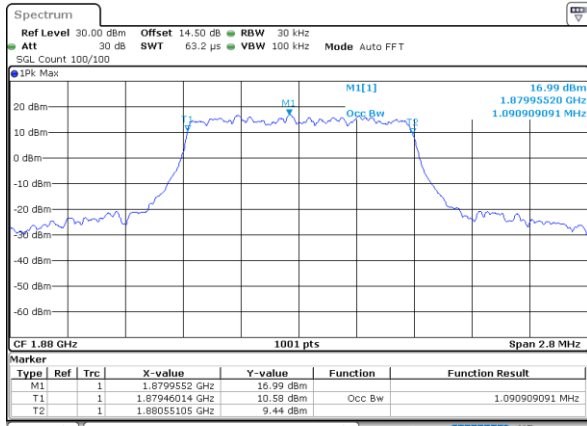

Date: 14.MAR.2024 22:32:06

Middle Channel / 1.4MHz / 16QAM

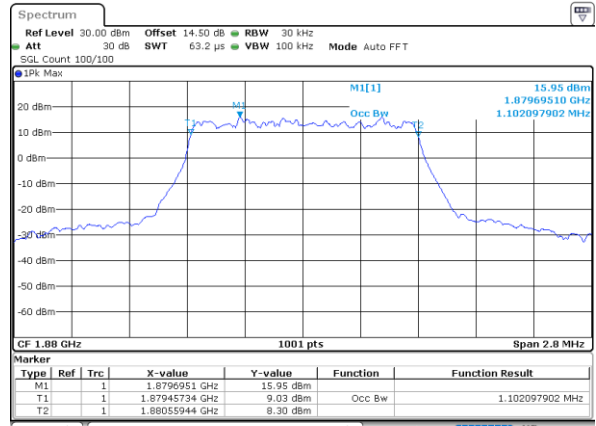

Date: 14.MAR.2024 22:32:47

Middle Channel / 3MHz / QPSK

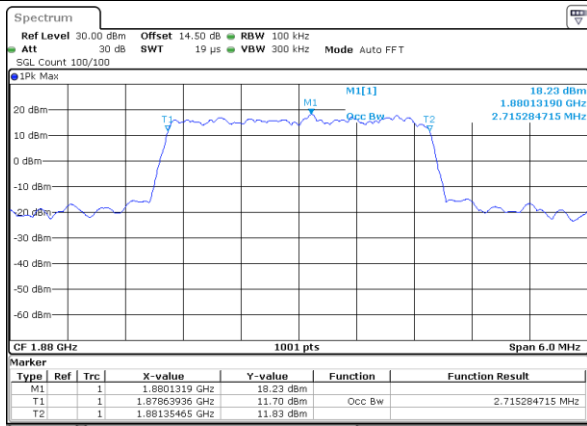

Date: 14.MAR.2024 22:51:13

Middle Channel / 3MHz / 16QAM

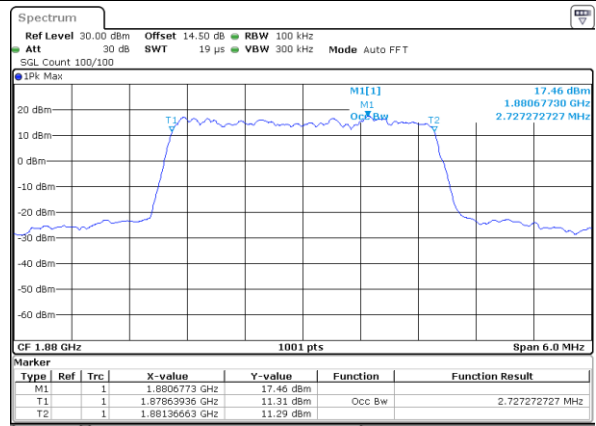

Date: 14.MAR.2024 22:51:54

Middle Channel / 5MHz / QPSK

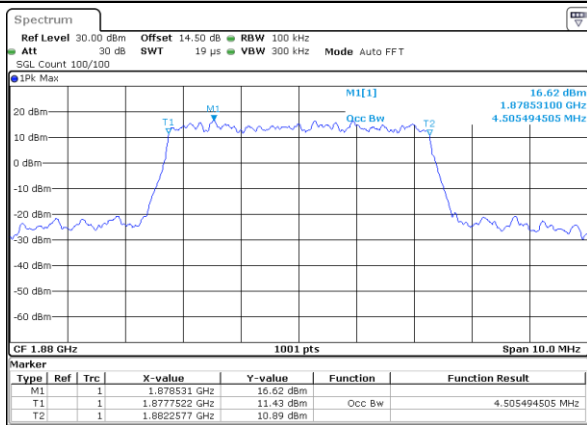

Date: 14.MAR.2024 23:22:29

Middle Channel / 5MHz / 16QAM

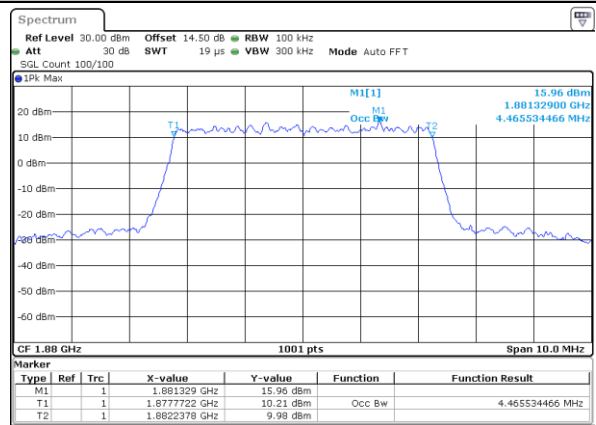

Date: 14.MAR.2024 23:23:10



LTE Band 25

Middle Channel / 10MHz / QPSK

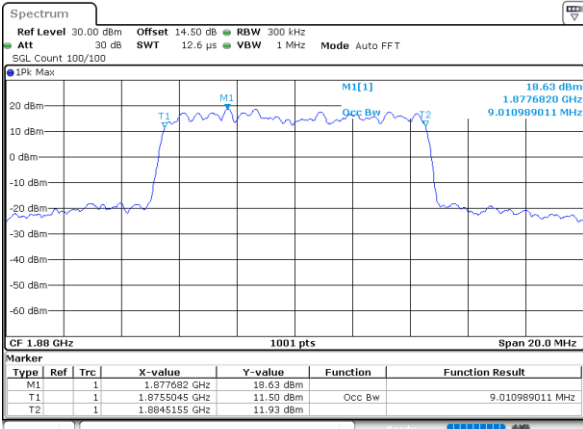

Date: 14_MAR_2024 23:41:38

Middle Channel / 10MHz / 16QAM

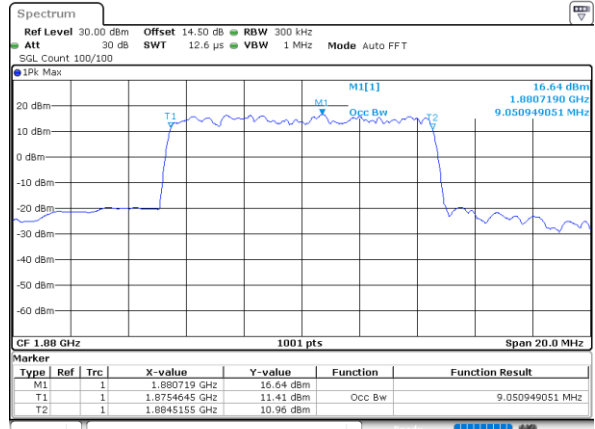

Date: 14_MAR_2024 23:42:19

Middle Channel / 15MHz / QPSK

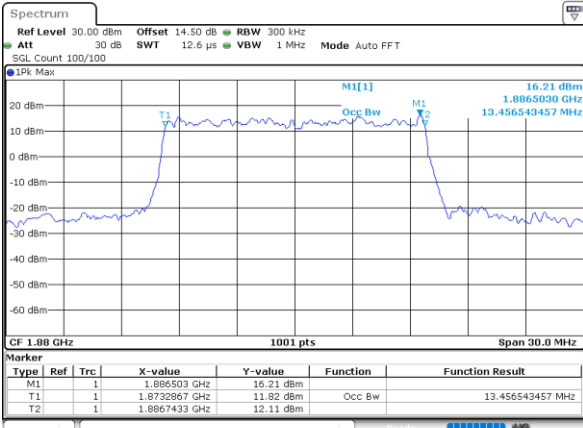

Date: 15_MAR_2024 00:03:39

Middle Channel / 15MHz / 16QAM

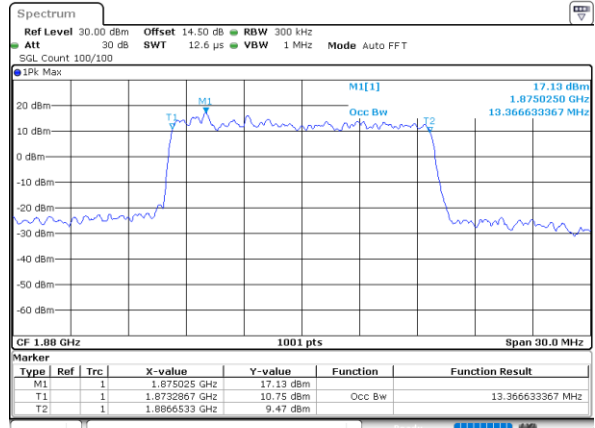

Date: 15_MAR_2024 00:04:20

Middle Channel / 20MHz / QPSK

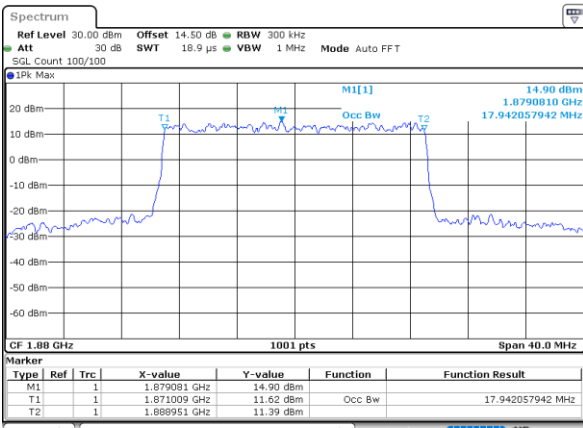

Date: 15_MAR_2024 00:21:40

Middle Channel / 20MHz / 16QAM

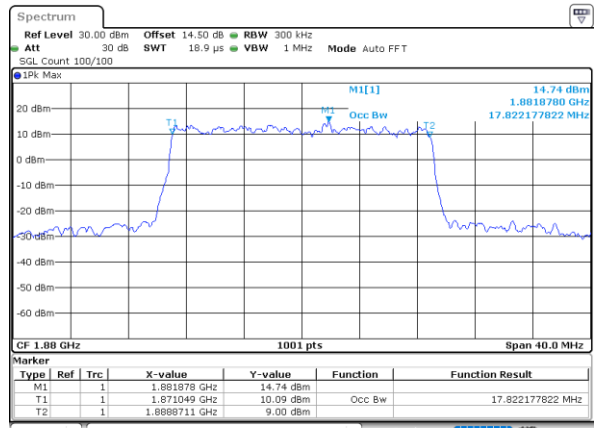

Date: 15_MAR_2024 00:22:20



Conducted Band Edge

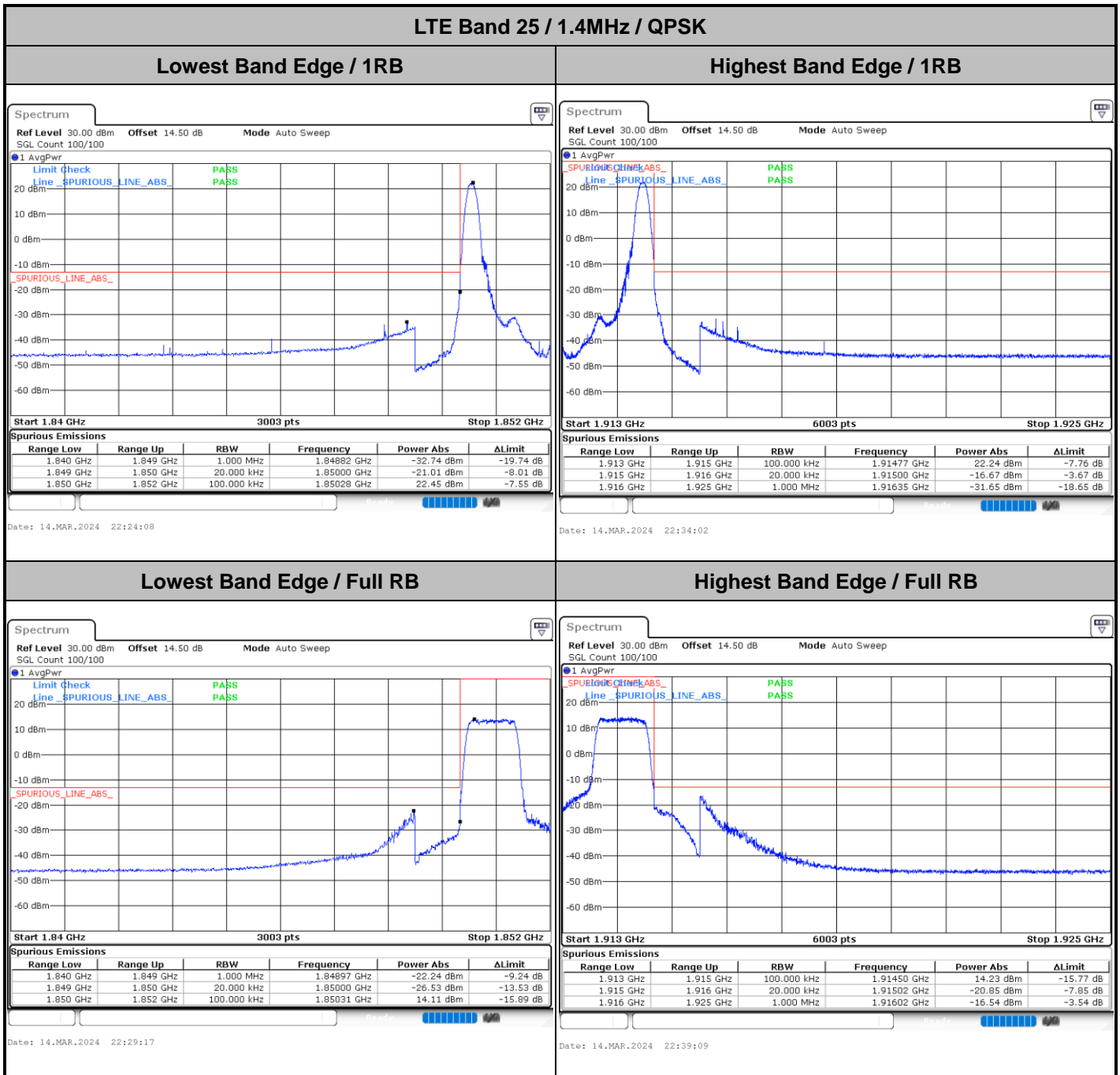



LTE Band 25 / 1.4MHz / 16QAM

Lowest Band Edge / 1 RB

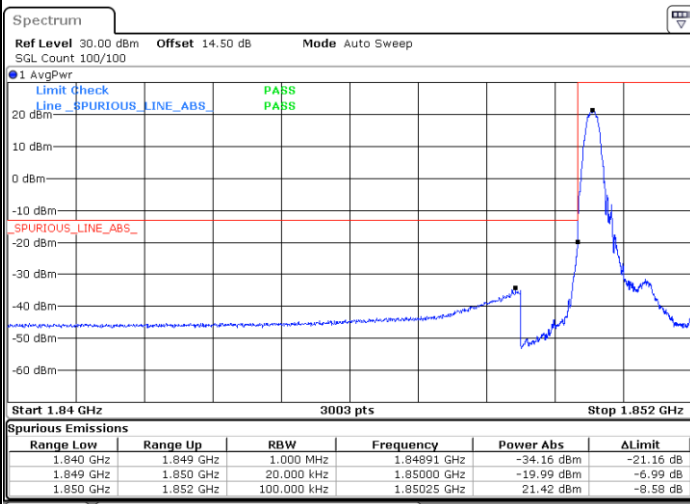

Date: 14.MAR.2024 22:25:10

Highest Band Edge / 1 RB

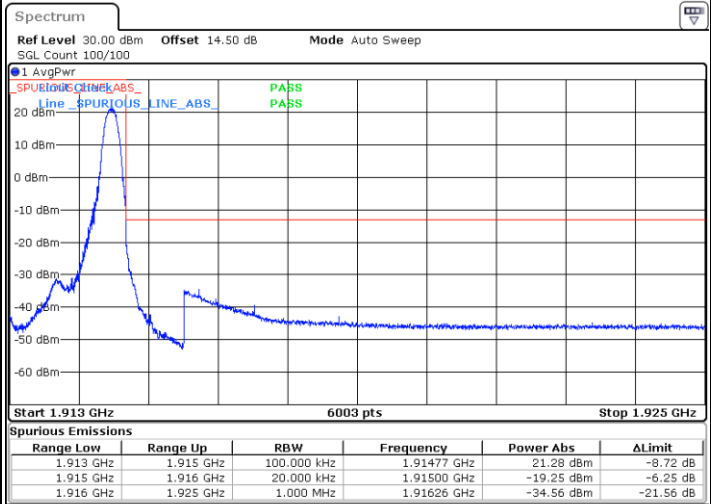

Date: 14.MAR.2024 22:35:03

Lowest Band Edge / Full RB

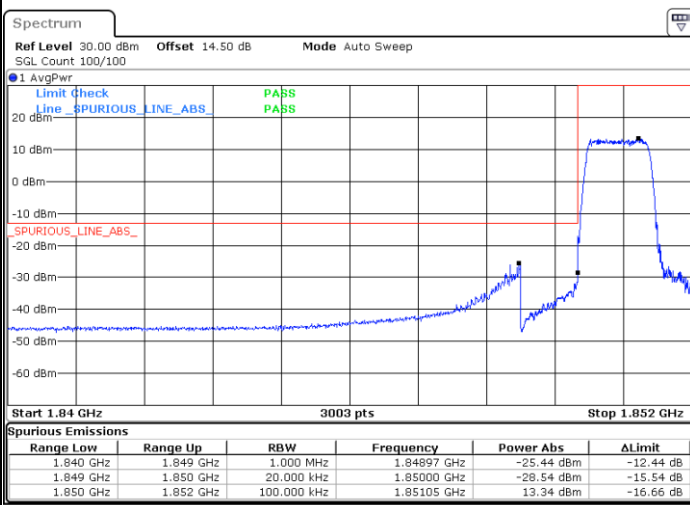

Date: 14.MAR.2024 22:28:15

Highest Band Edge / Full RB

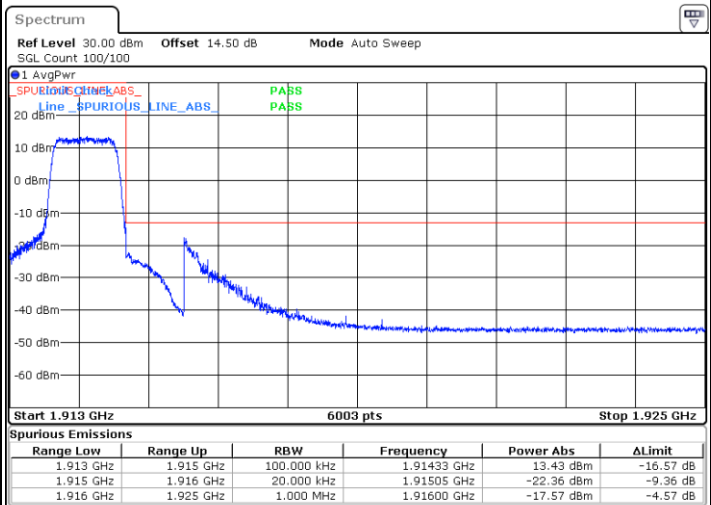

Date: 14.MAR.2024 22:38:08



LTE Band 25 / 1.4MHz / 64QAM

Lowest Band Edge / 1 RB

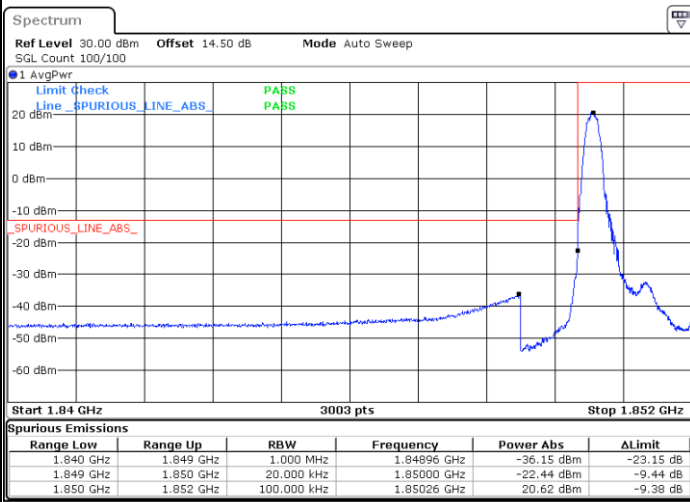

Date: 14.MAR.2024 22:26:12

Highest Band Edge / 1 RB

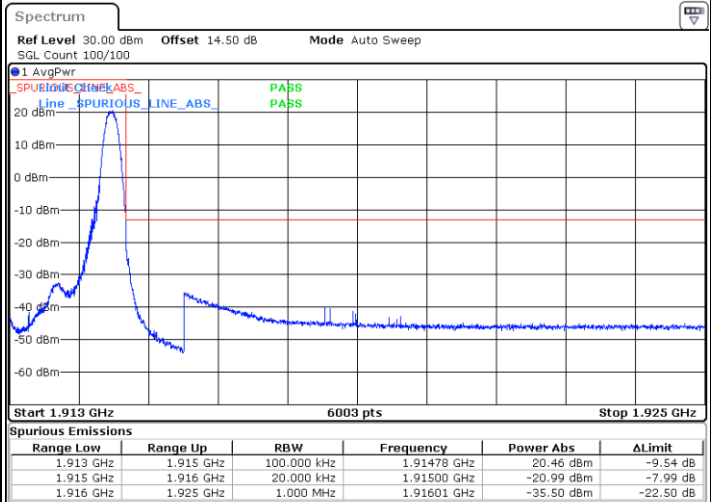

Date: 14.MAR.2024 22:36:05

Lowest Band Edge / Full RB

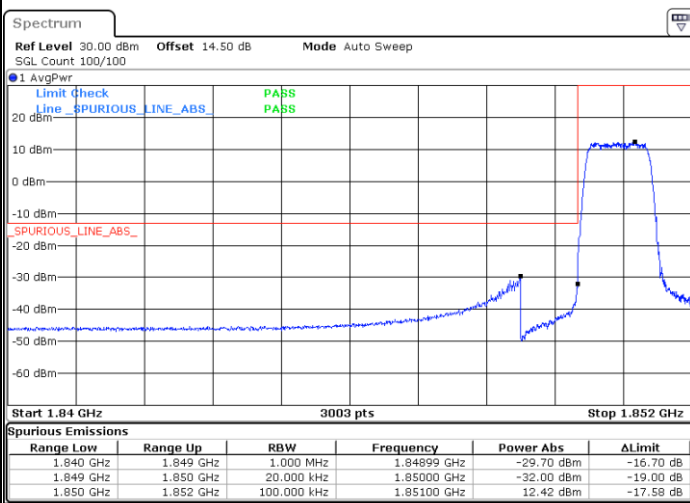

Date: 14.MAR.2024 22:27:13

Highest Band Edge / Full RB

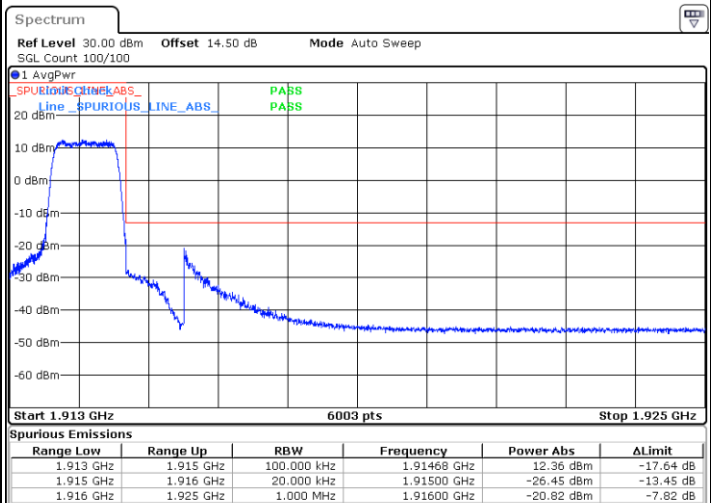

Date: 14.MAR.2024 22:37:06



LTE Band 25 / 3MHz / QPSK

Lowest Band Edge / 1RB

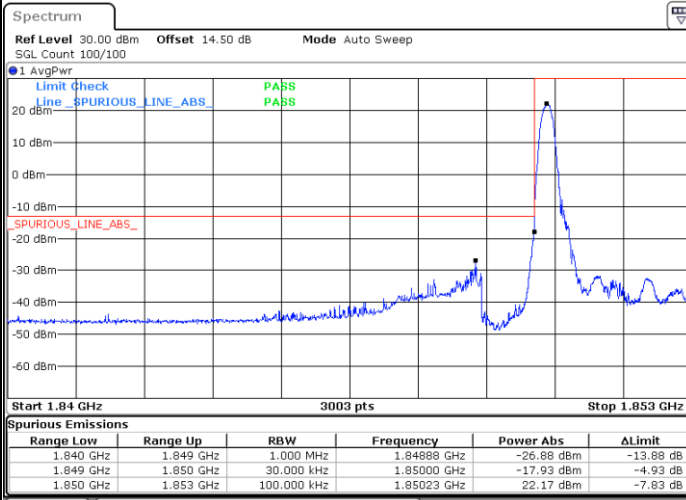

Date: 14.MAR.2024 22:43:17

Highest Band Edge / 1RB

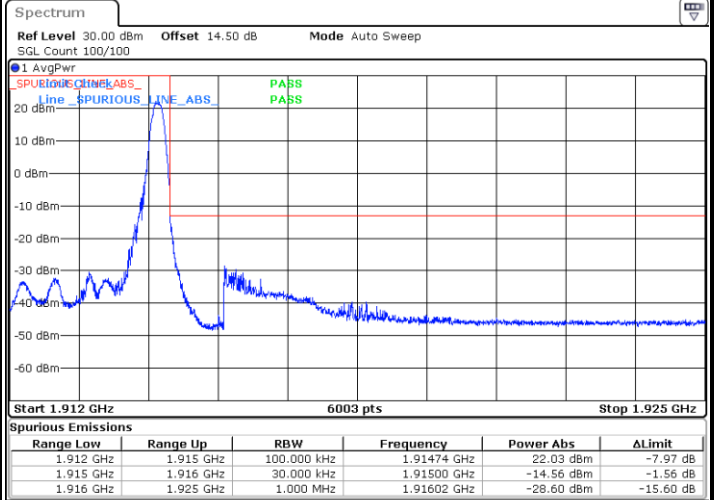

Date: 14.MAR.2024 22:53:09

Lowest Band Edge / Full RB

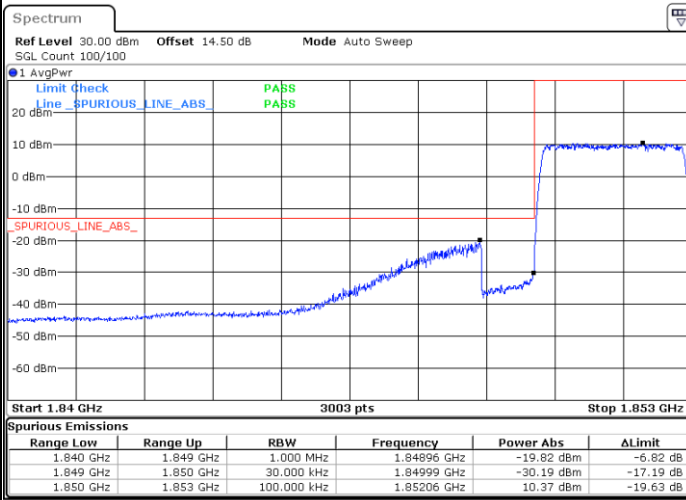

Date: 14.MAR.2024 22:48:24

Highest Band Edge / Full RB

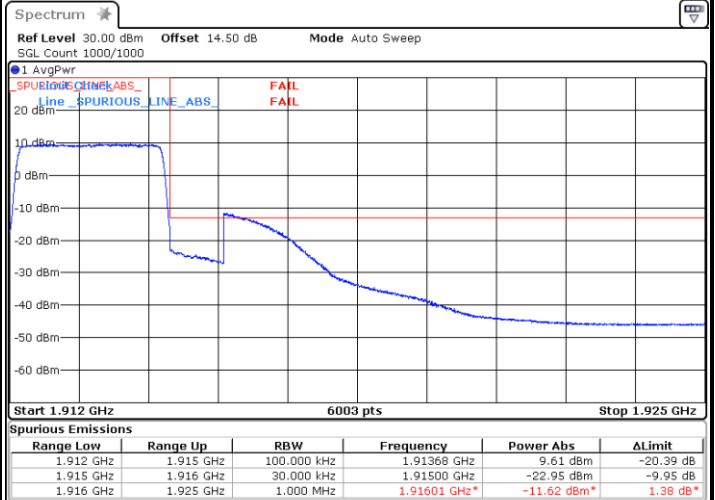

Date: 15.MAR.2024 01:10:21



Lowest Band Edge / Full RB -CP

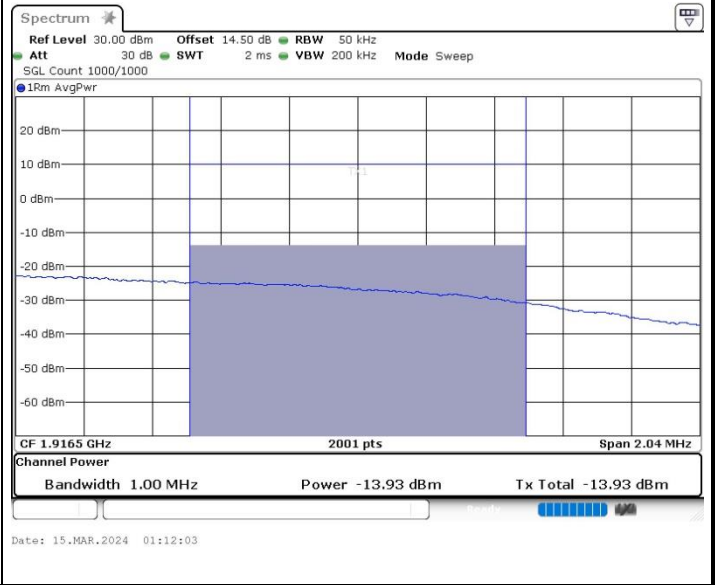



LTE Band 25 / 3MHz / 16QAM

Lowest Band Edge / 1 RB

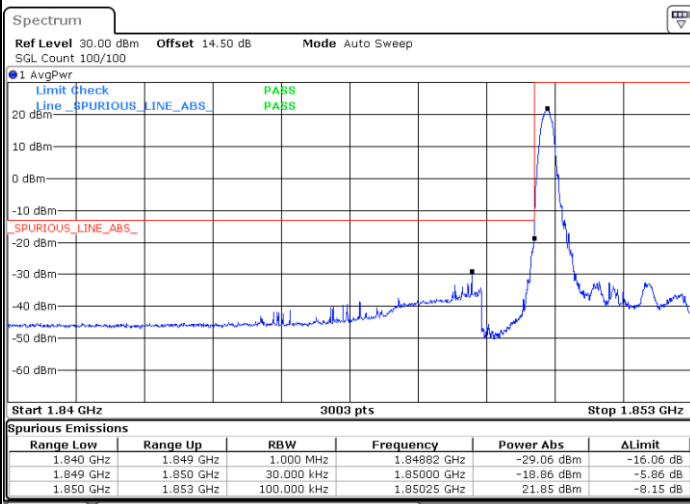

Date: 14.MAR.2024 22:44:19

Highest Band Edge / 1 RB

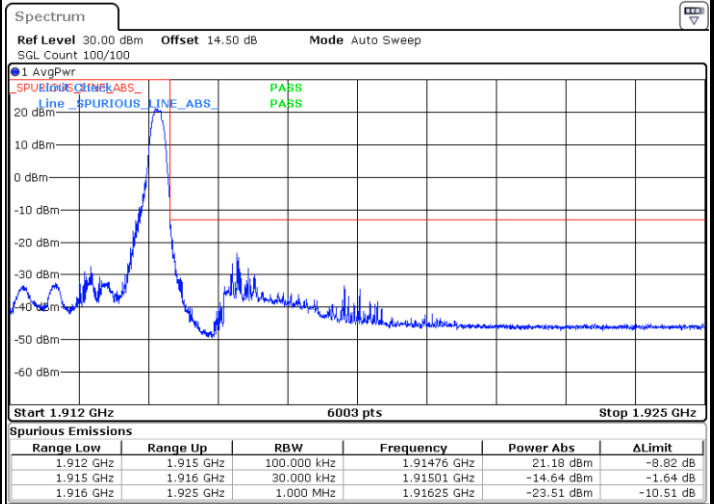

Date: 14.MAR.2024 22:54:11

Lowest Band Edge / Full RB

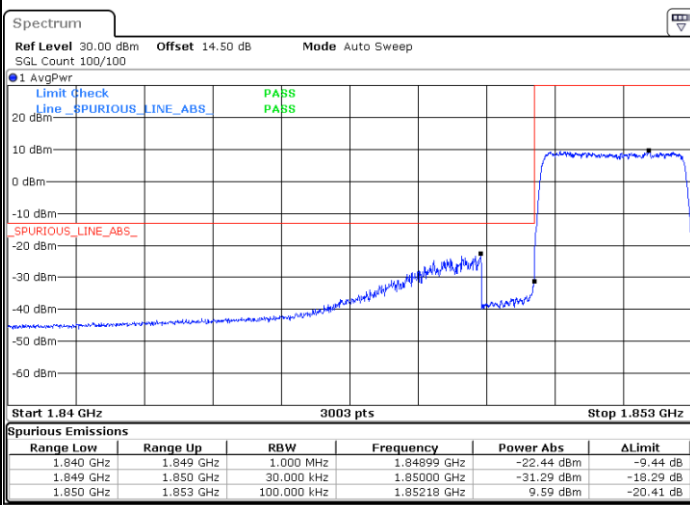

Date: 14.MAR.2024 22:47:23

Highest Band Edge / Full RB

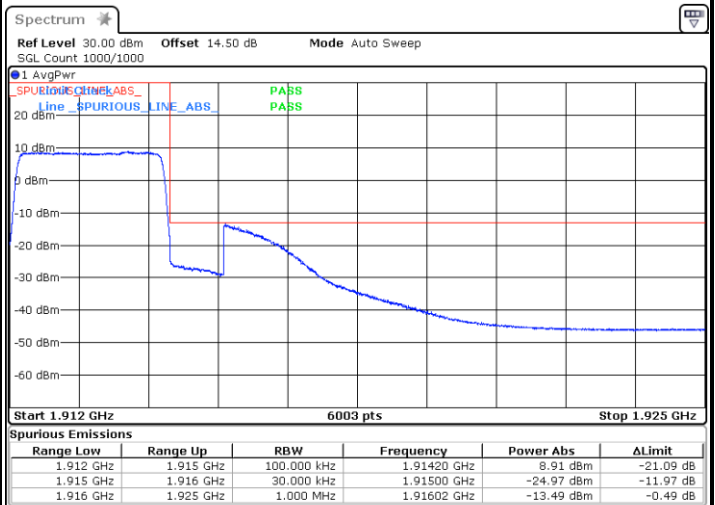

Date: 15.MAR.2024 01:09:23



LTE Band 25 / 3MHz / 64QAM

Lowest Band Edge / 1 RB

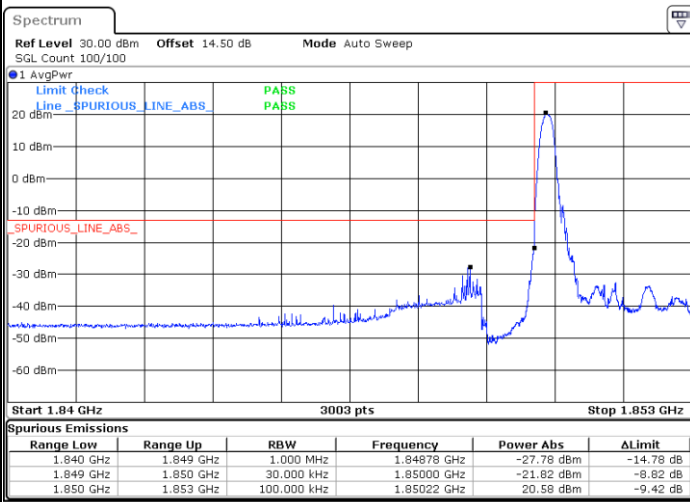

Date: 14.MAR.2024 22:45:20

Highest Band Edge / 1 RB

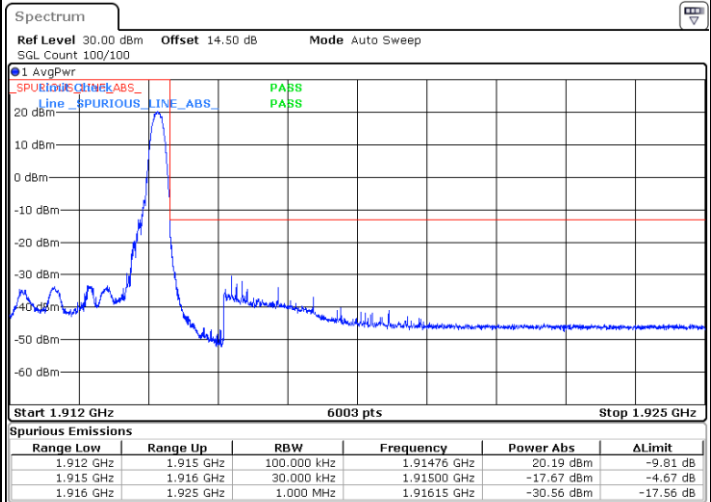

Date: 14.MAR.2024 22:55:12

Lowest Band Edge / Full RB

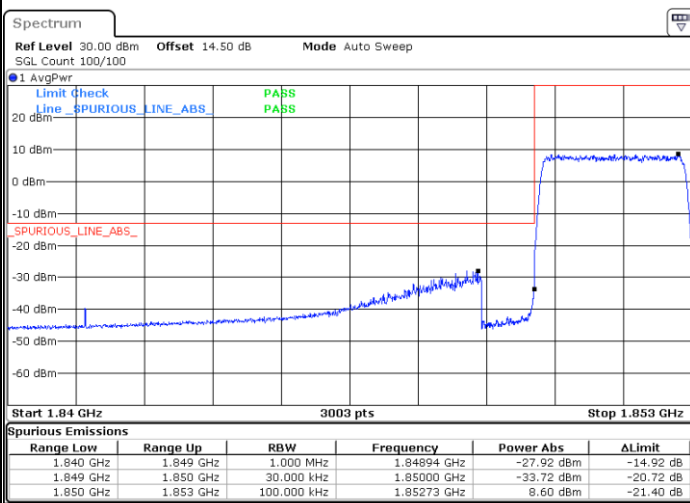

Date: 14.MAR.2024 22:46:22

Highest Band Edge / Full RB

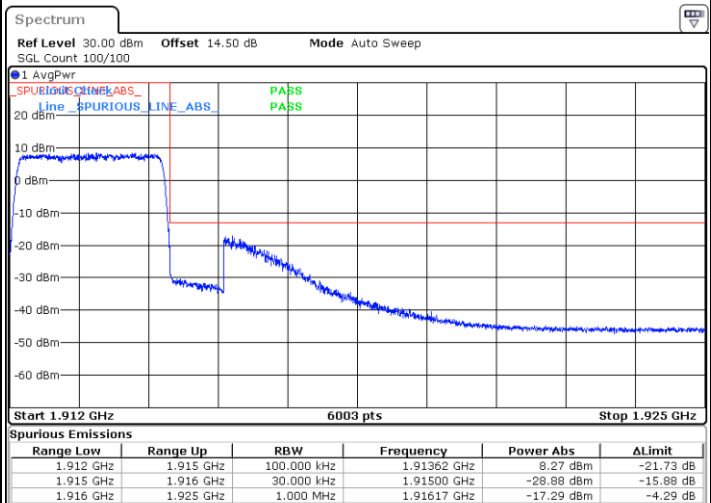

Date: 14.MAR.2024 22:56:13



LTE Band 25 / 5MHz / QPSK

Lowest Band Edge / 1RB

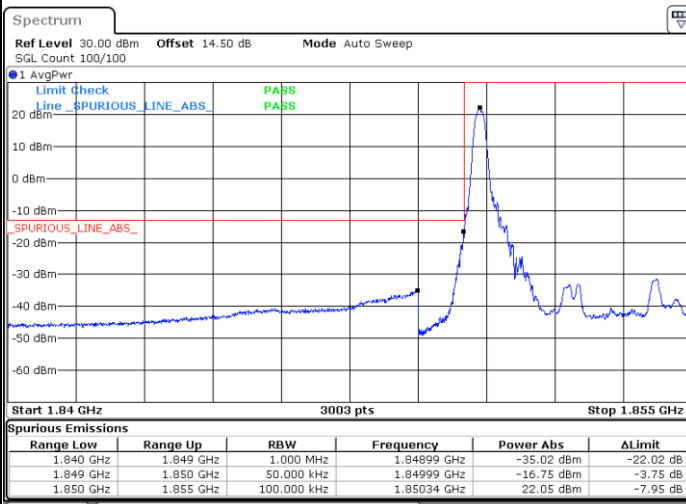

Date: 14.MAR.2024 23:14:32

Highest Band Edge / 1RB

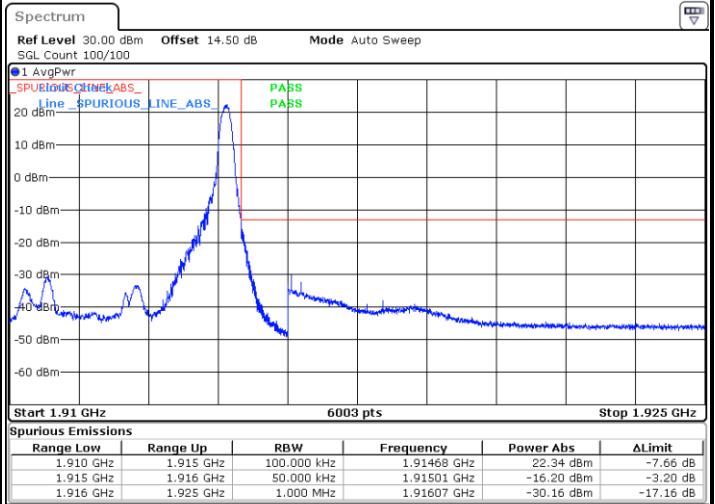

Date: 14.MAR.2024 23:24:25

Lowest Band Edge / Full RB

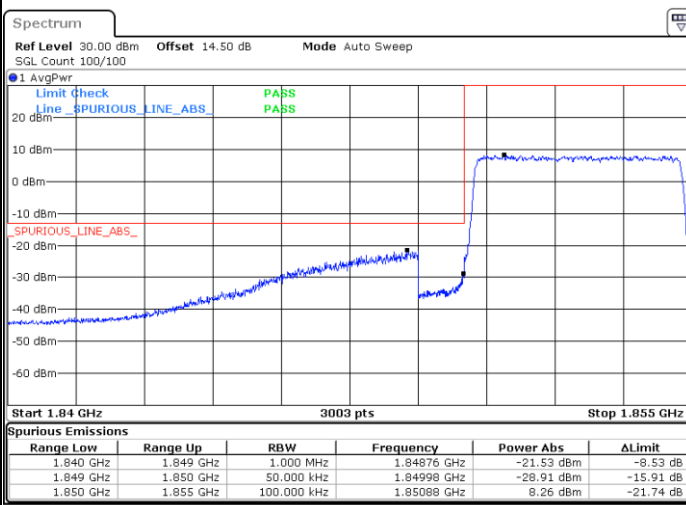

Date: 14.MAR.2024 23:19:40

Highest Band Edge / Full RB

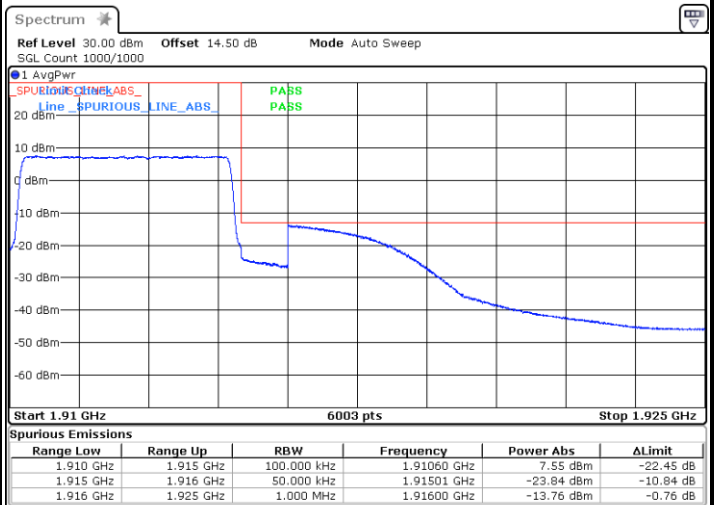

Date: 15.MAR.2024 01:14:32



LTE Band 25 / 5MHz / 16QAM

Lowest Band Edge / 1 RB

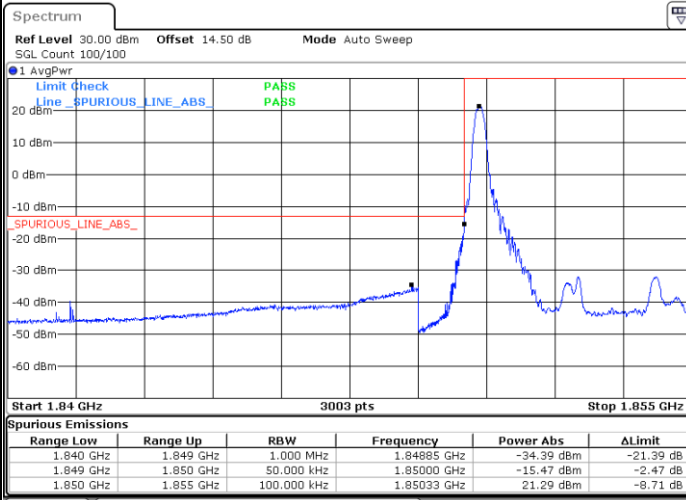

Date: 14.MAR.2024 23:15:34

Highest Band Edge / 1 RB

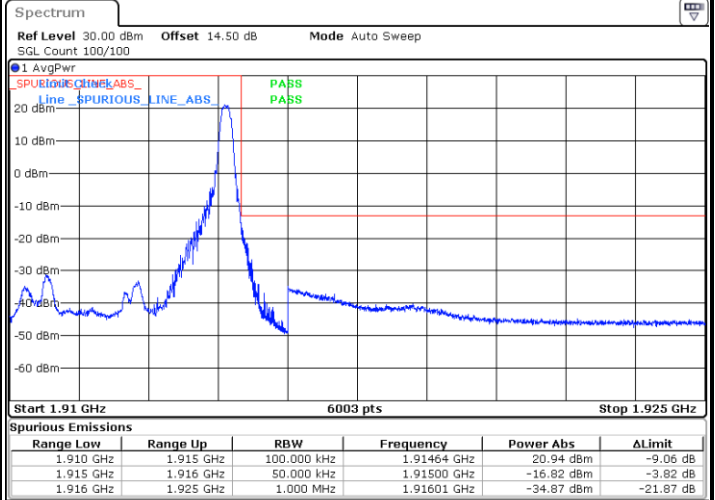

Date: 14.MAR.2024 23:25:26

Lowest Band Edge / Full RB

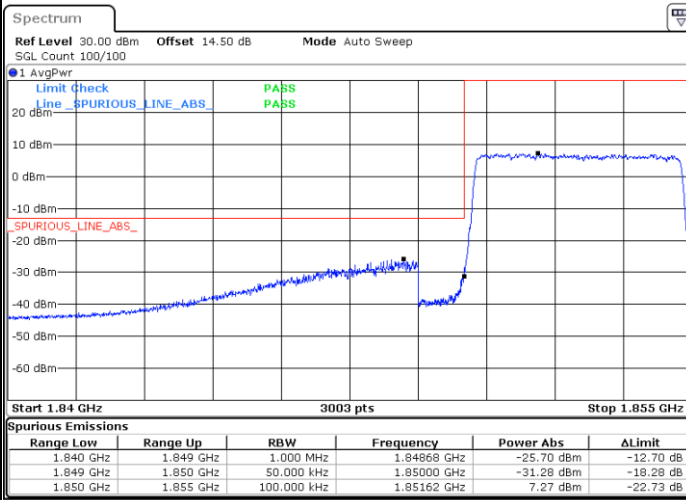

Date: 14.MAR.2024 23:18:39

Highest Band Edge / Full RB

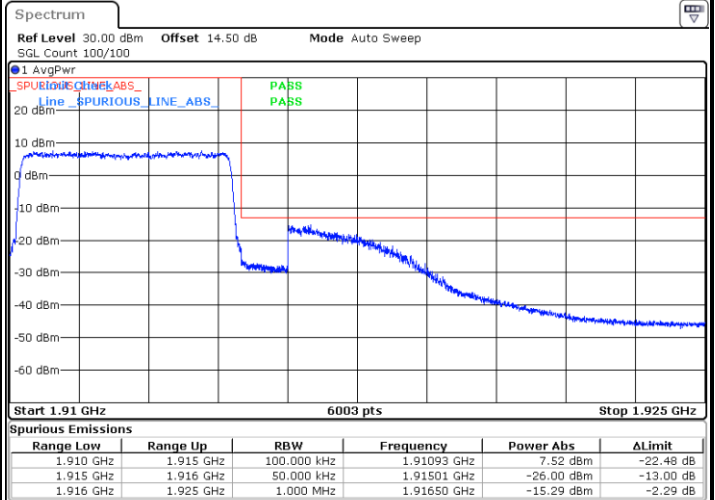

Date: 14.MAR.2024 23:28:31



LTE Band 25 / 5MHz / 64QAM

Lowest Band Edge / 1 RB

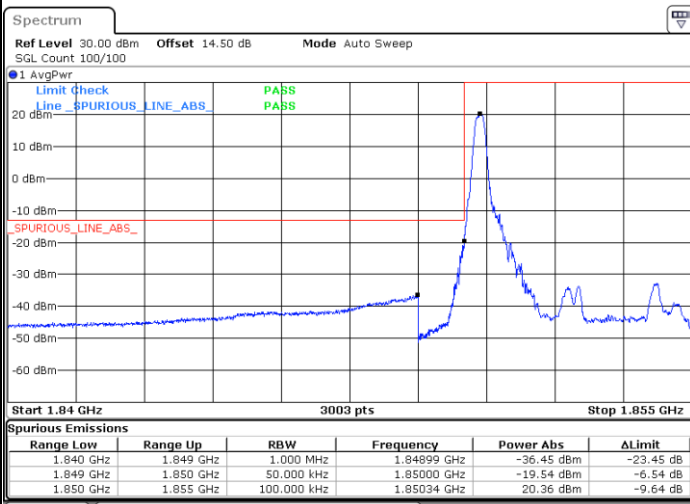

Date: 14.MAR.2024 23:16:35

Highest Band Edge / 1 RB

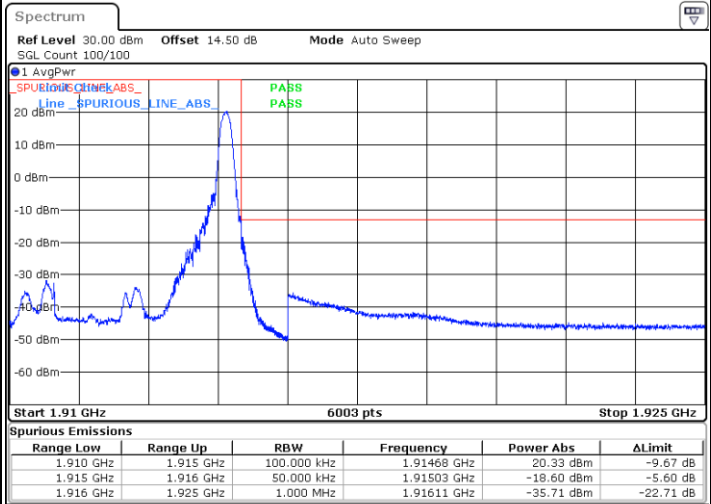

Date: 14.MAR.2024 23:26:28

Lowest Band Edge / Full RB

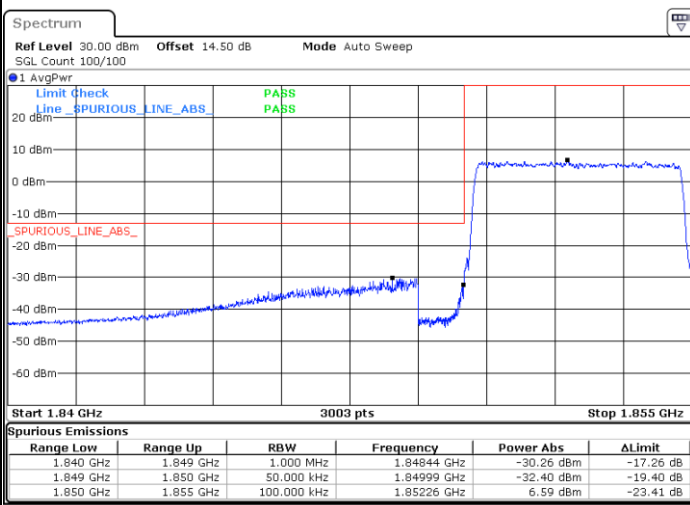

Date: 14.MAR.2024 23:17:37

Highest Band Edge / Full RB

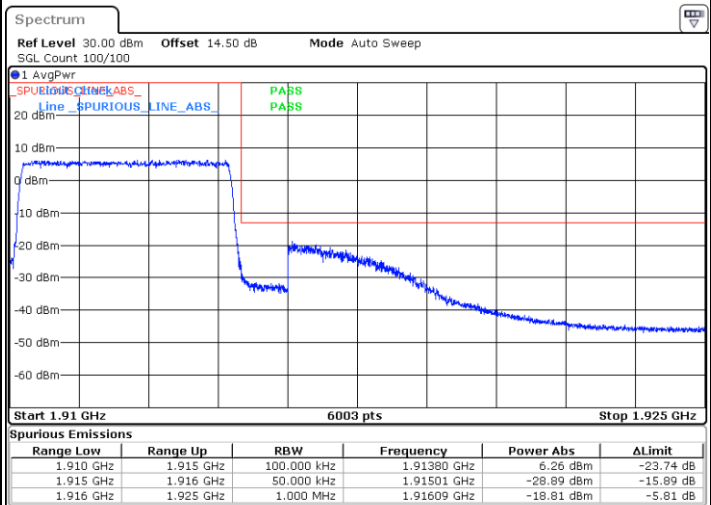

Date: 14.MAR.2024 23:27:29



LTE Band 25 / 10MHz / QPSK

Lowest Band Edge / 1RB

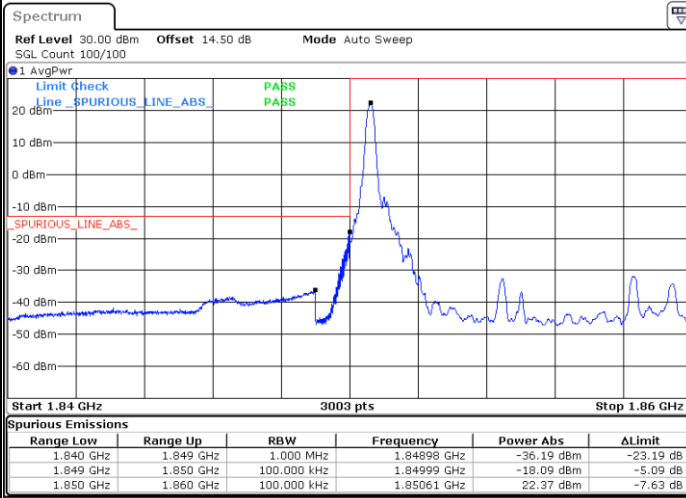

Date: 14.MAR.2024 23:33:41

Highest Band Edge / 1RB

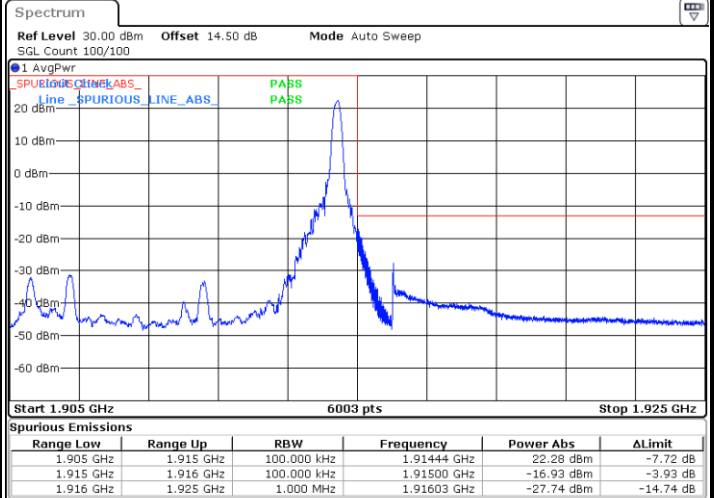

Date: 14.MAR.2024 23:43:34

Lowest Band Edge / Full RB

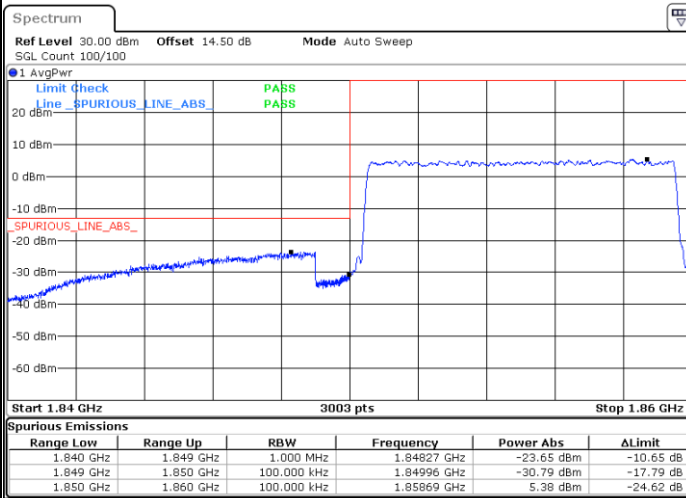

Date: 14.MAR.2024 23:38:49

Highest Band Edge / Full RB

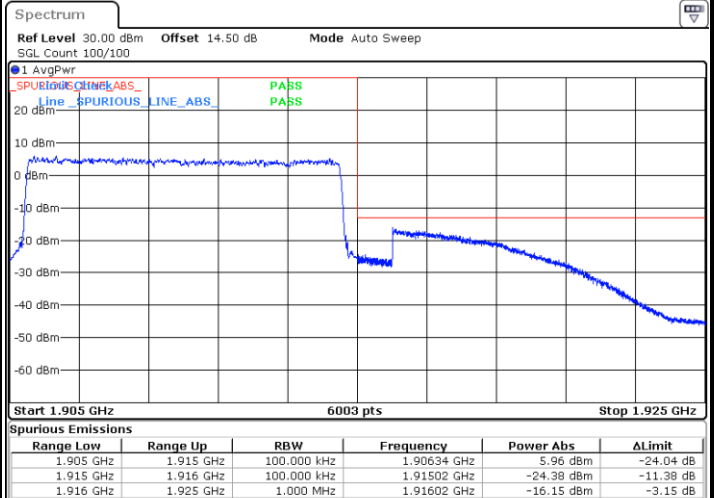

Date: 14.MAR.2024 23:48:42



LTE Band 25 / 10MHz / 16QAM

Lowest Band Edge / 1 RB

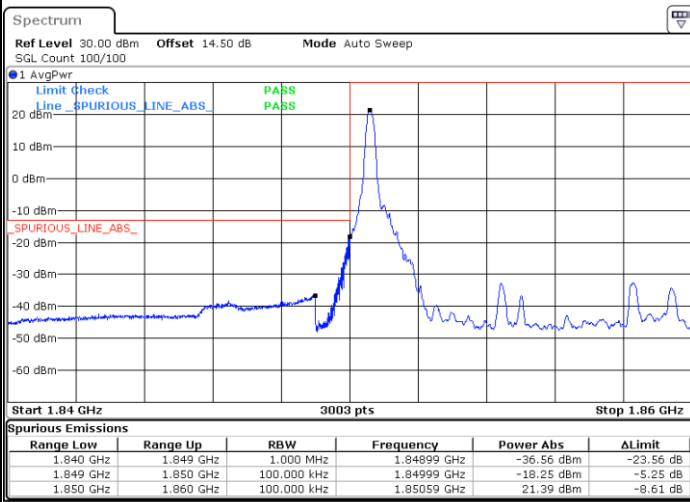

Date: 14.MAR.2024 23:34:43

Highest Band Edge / 1 RB

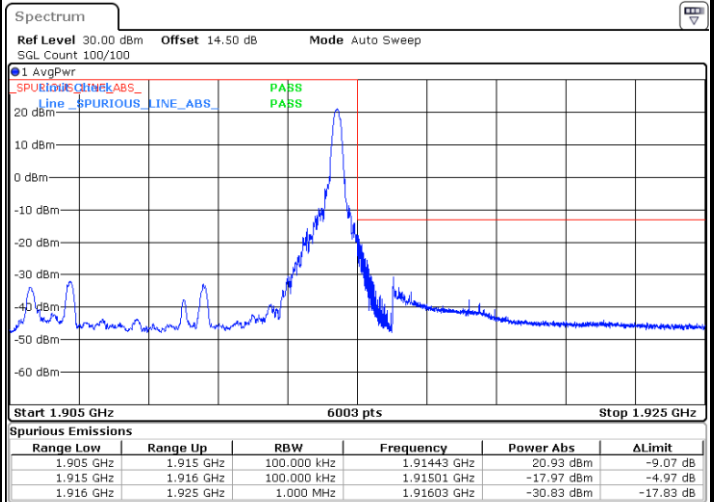

Date: 14.MAR.2024 23:44:35

Lowest Band Edge / Full RB

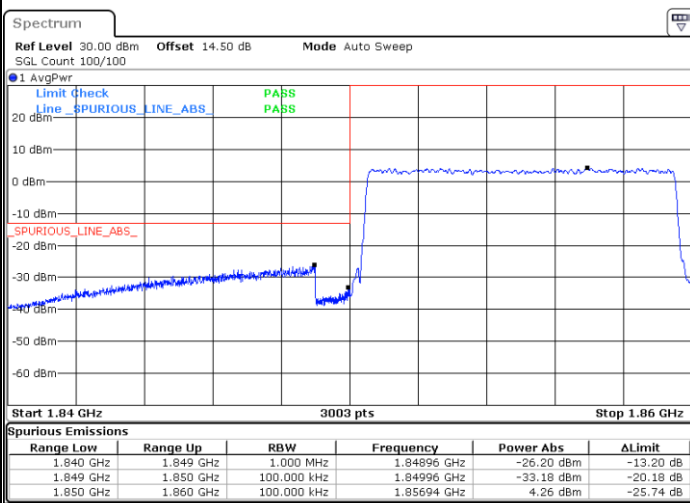

Date: 14.MAR.2024 23:37:47

Highest Band Edge / Full RB

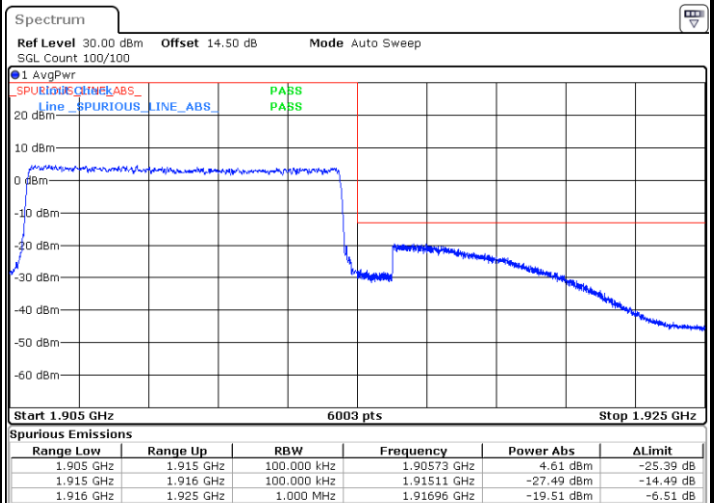

Date: 14.MAR.2024 23:47:41



LTE Band 25 / 10MHz / 64QAM

Lowest Band Edge / 1 RB

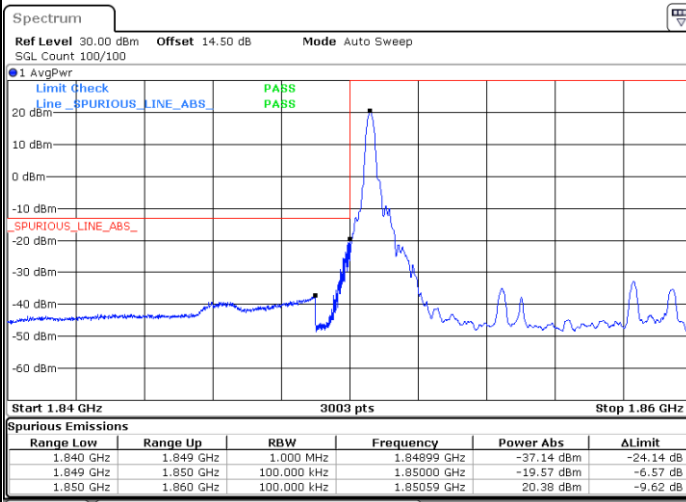

Date: 14.MAR.2024 23:35:44

Highest Band Edge / 1 RB

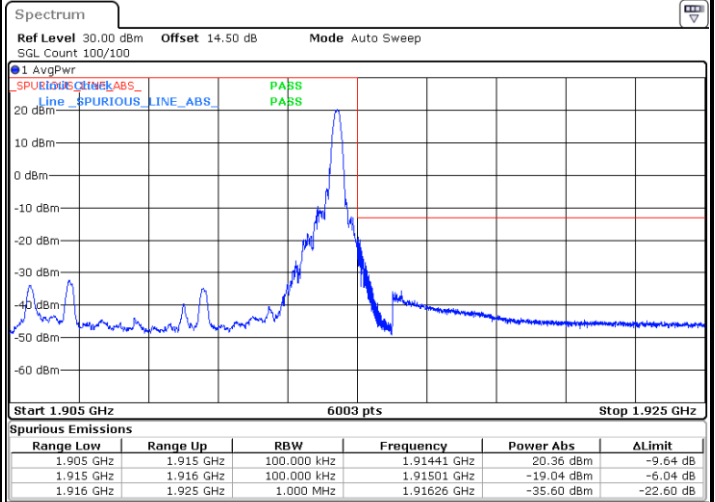

Date: 14.MAR.2024 23:45:37

Lowest Band Edge / Full RB

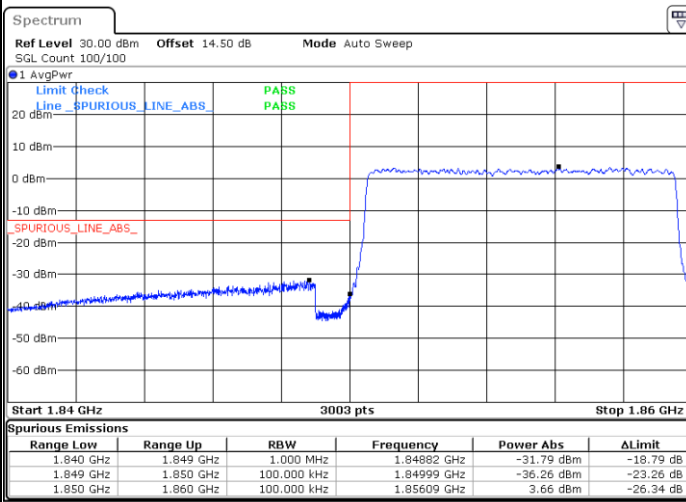

Date: 14.MAR.2024 23:36:46

Highest Band Edge / Full RB

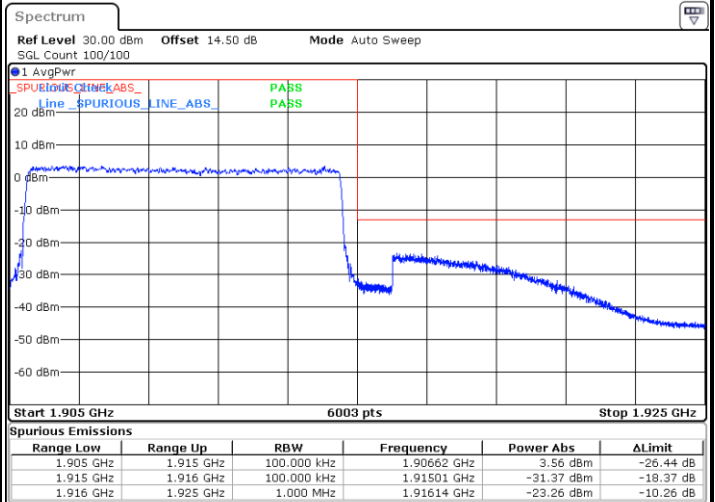

Date: 14.MAR.2024 23:46:39



LTE Band 25 / 15MHz / QPSK

Lowest Band Edge / 1RB

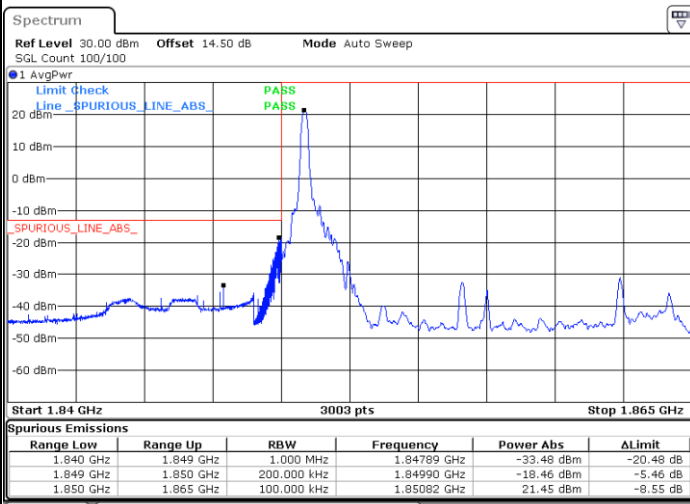

Date: 14.MAR.2024 23:55:42

Highest Band Edge / 1RB

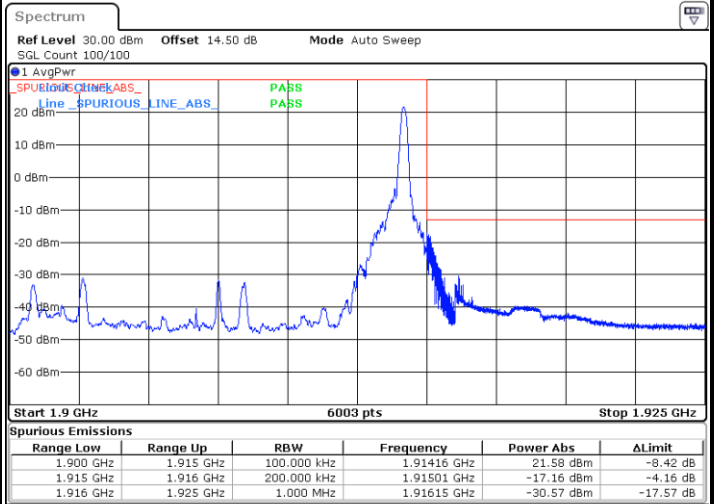

Date: 15.MAR.2024 00:05:34

Lowest Band Edge / Full RB

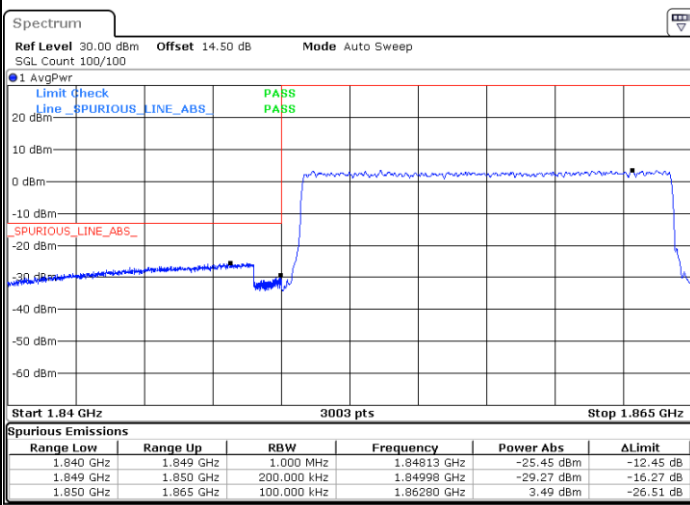

Date: 15.MAR.2024 00:00:49

Highest Band Edge / Full RB

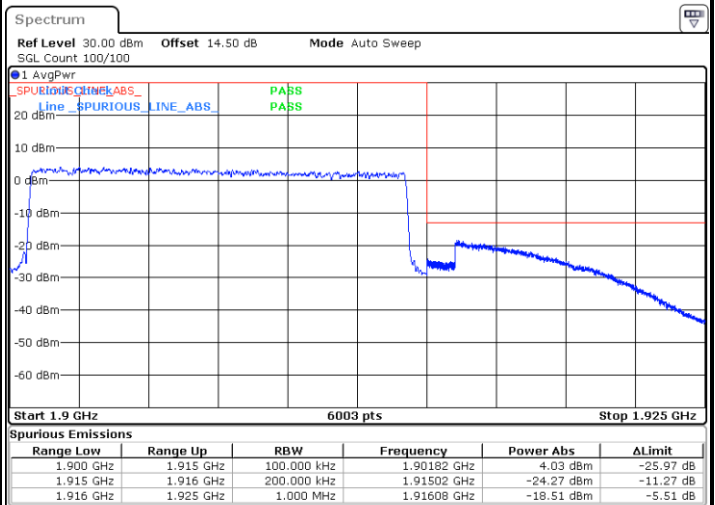

Date: 15.MAR.2024 00:10:42



LTE Band 25 / 15MHz / 16QAM

Lowest Band Edge / 1 RB

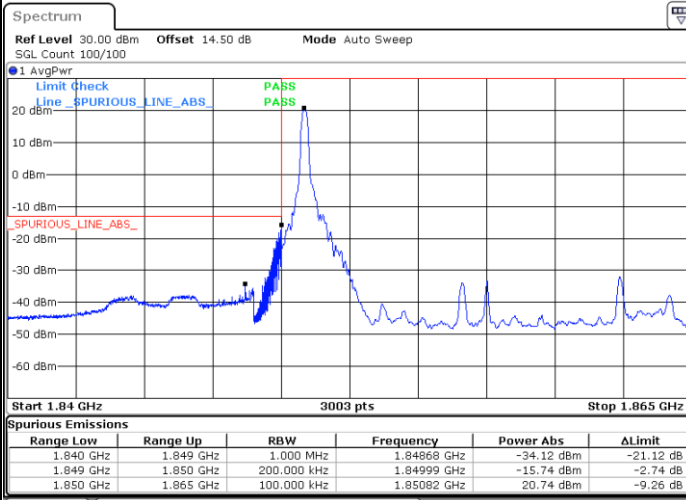

Date: 14.MAR.2024 23:56:43

Highest Band Edge / 1 RB

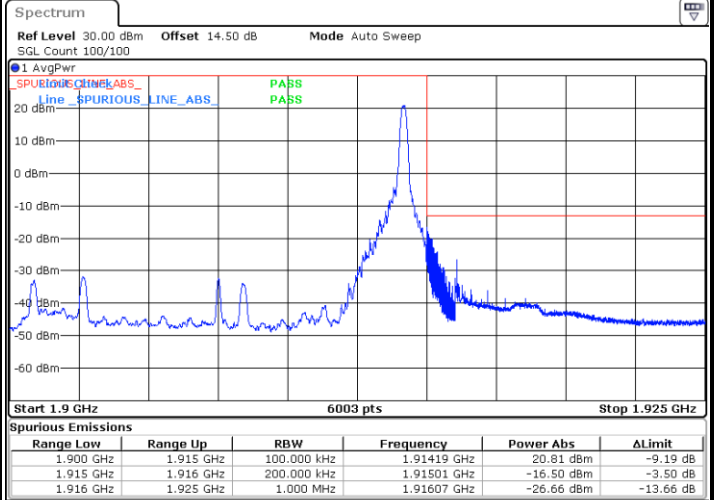

Date: 15.MAR.2024 00:06:36

Lowest Band Edge / Full RB

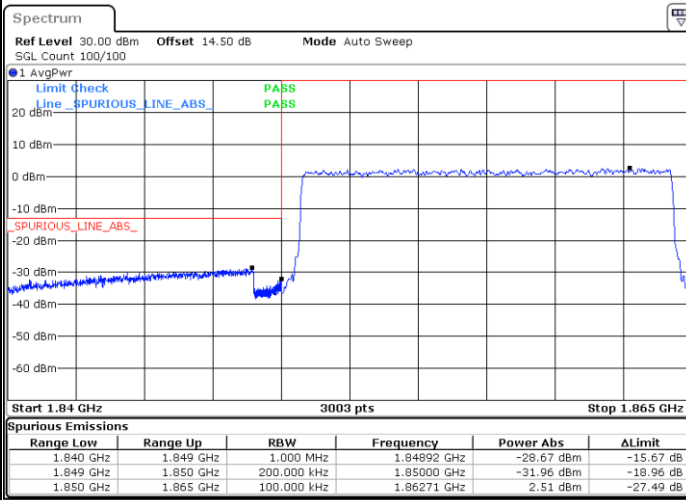

Date: 14.MAR.2024 23:59:48

Highest Band Edge / Full RB

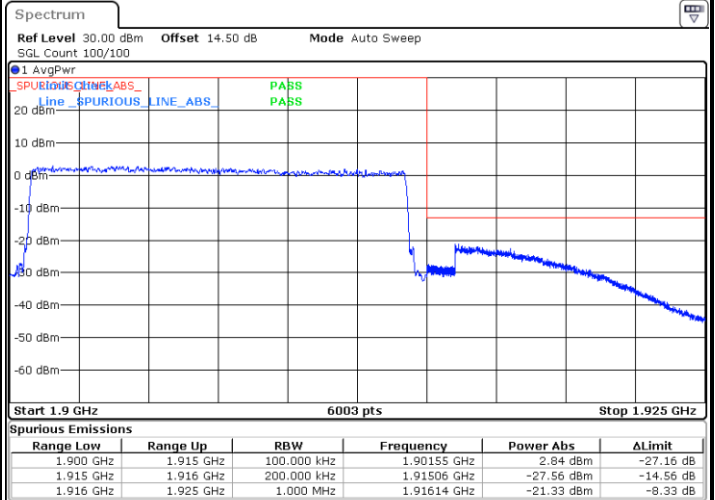

Date: 15.MAR.2024 00:09:41



LTE Band 25 / 15MHz / 64QAM

Lowest Band Edge / 1 RB

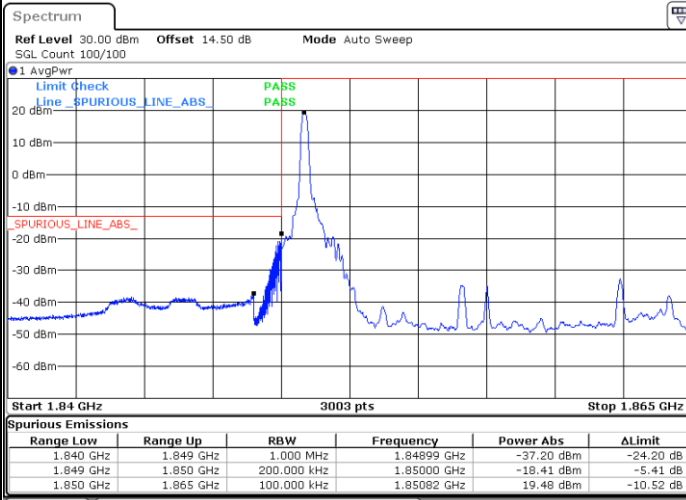

Date: 14.MAR.2024 23:57:45

Highest Band Edge / 1 RB

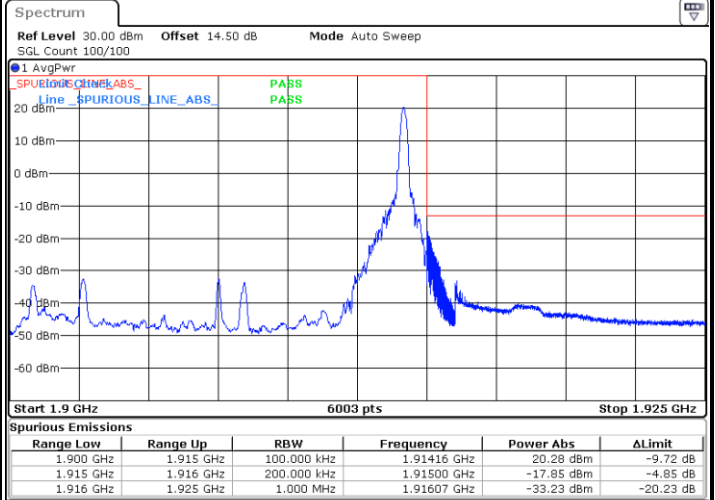

Date: 15.MAR.2024 00:07:37

Lowest Band Edge / Full RB

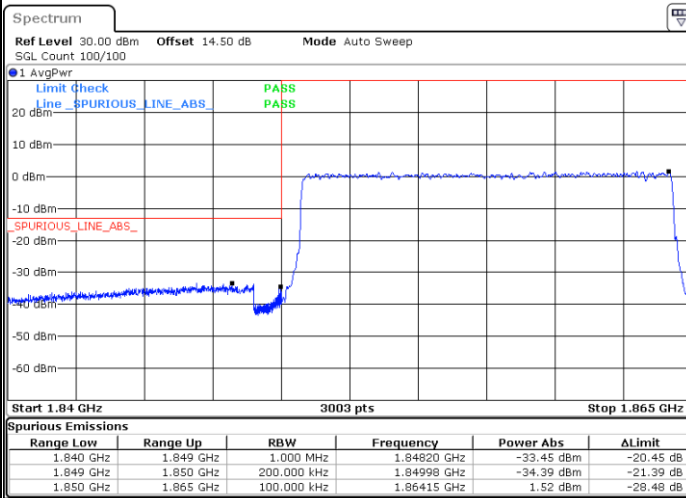

Date: 14.MAR.2024 23:58:47

Highest Band Edge / Full RB

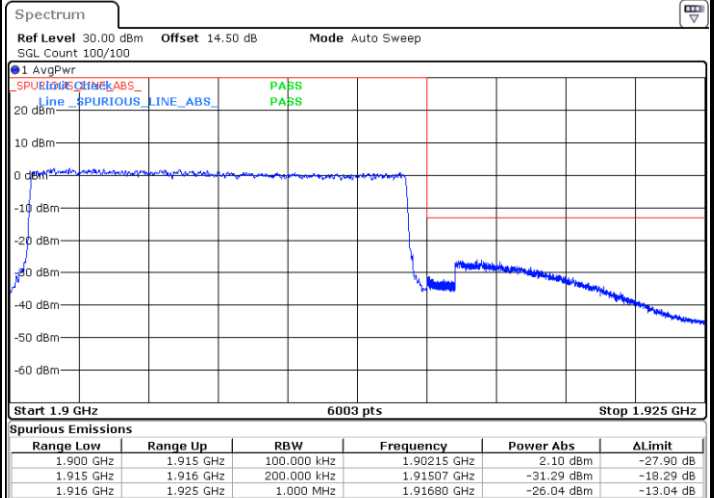

Date: 15.MAR.2024 00:08:39



LTE Band 25 / 20MHz / QPSK

Lowest Band Edge / 1RB

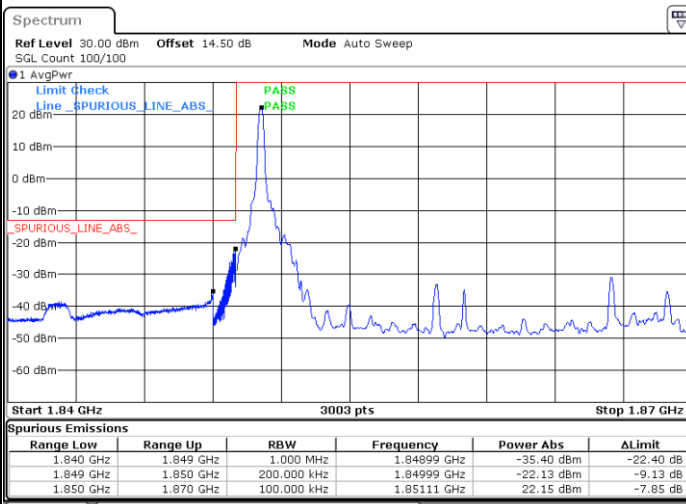

Date: 15.MAR.2024 00:13:42

Highest Band Edge / 1RB

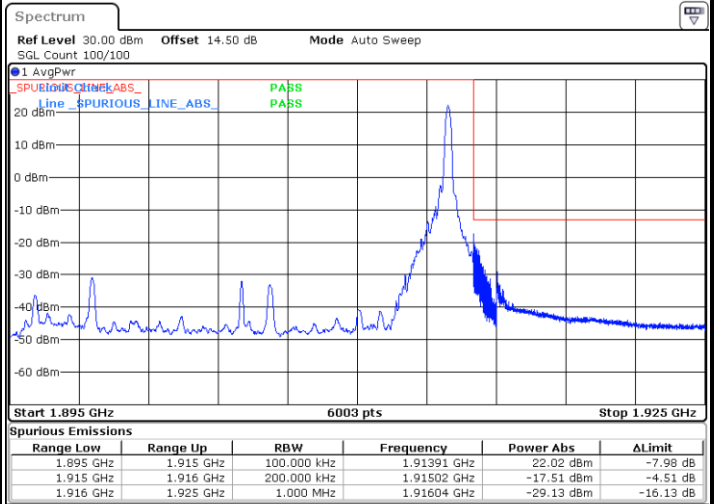

Date: 15.MAR.2024 00:25:00

Lowest Band Edge / Full RB

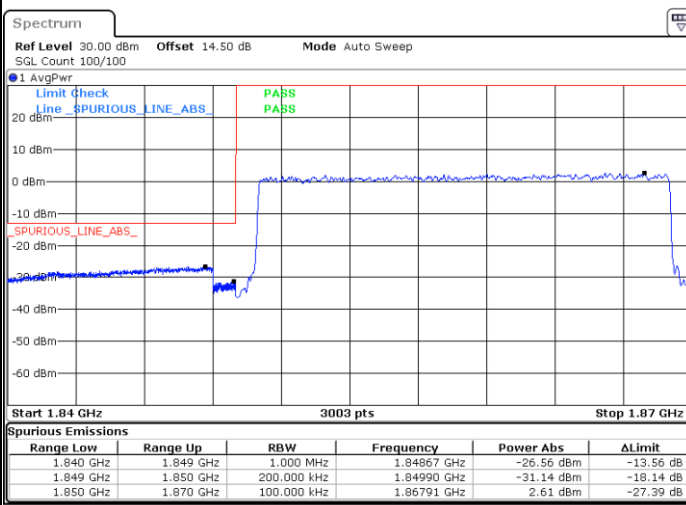

Date: 15.MAR.2024 00:18:50

Highest Band Edge / Full RB

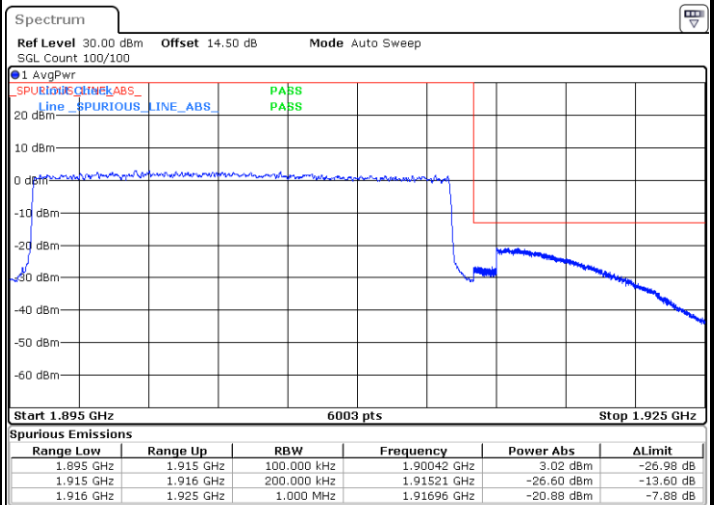

Date: 15.MAR.2024 00:30:08



LTE Band 25 / 20MHz / 16QAM

Lowest Band Edge / 1 RB

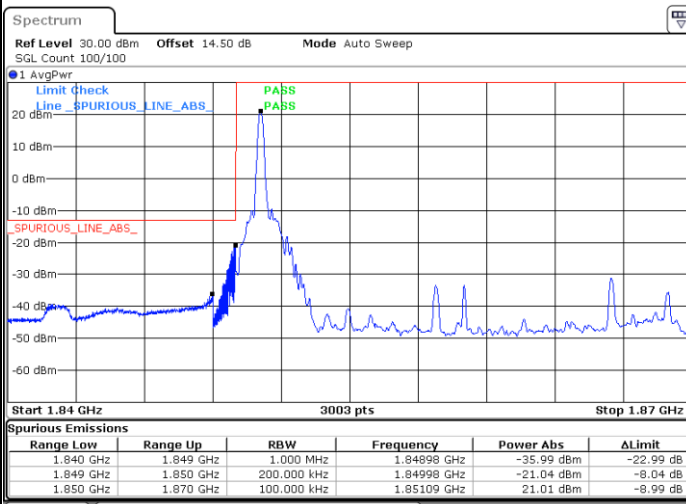

Date: 15.MAR.2024 00:14:44

Highest Band Edge / 1 RB

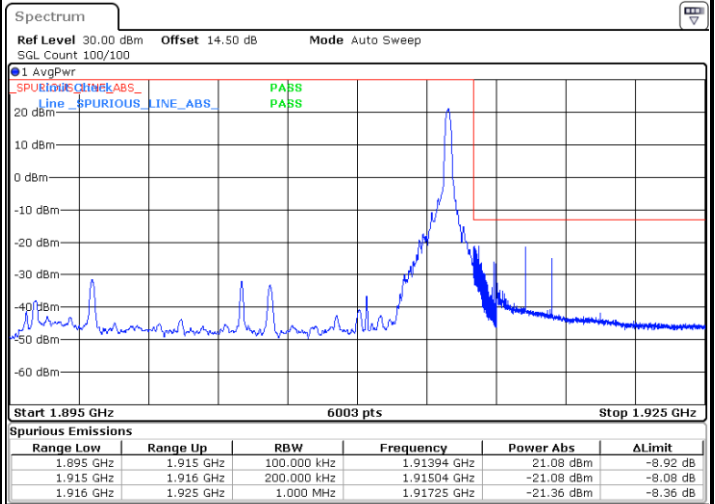

Date: 15.MAR.2024 00:26:01

Lowest Band Edge / Full RB

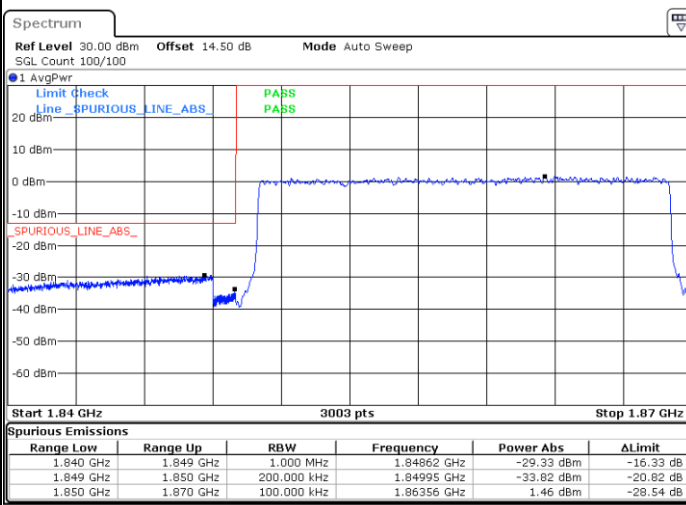

Date: 15.MAR.2024 00:17:49

Highest Band Edge / Full RB

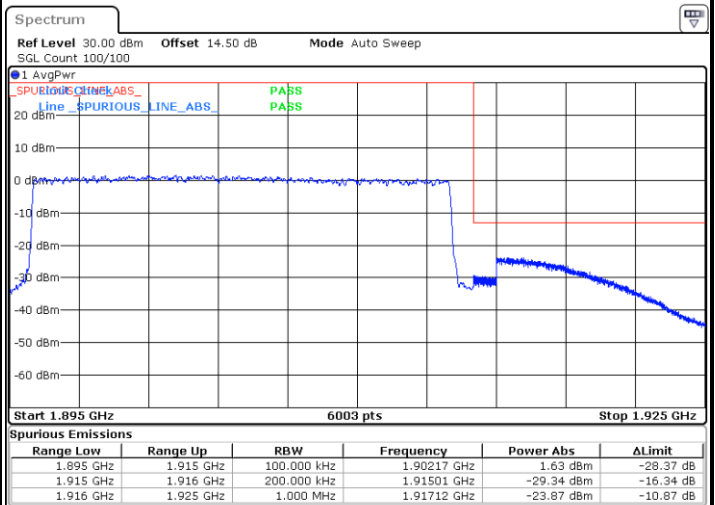

Date: 15.MAR.2024 00:29:06