



# SAR TEST REPORT

No. I21Z61640-SEM01

For

**TCL Communication Ltd.**

**GSM/UMTS/LTE Mobile phone**

**Model name: 5007S**

With

**Hardware Version: 04**

**Software Version: v2F21UZ10**

**FCC ID: 2ACCJH130**

**Issued Date: 2021-9-10**

**Note:**

The test results in this test report relate only to the devices specified in this report. This report shall not be reproduced except in full without the written approval of CTTL.

The report must not be used by the client to claim product certification, approval, or endorsement by NVLAP, NIST, or any agency of the U.S.Government.

**Test Laboratory:**

CTTL, Telecommunication Technology Labs, CAICT

No. 51, Xueyuan Road, Haidian District, Beijing, P. R. China 100191.

Tel:+86(0)10-62304633-2512, Fax:+86(0)10-62304633-2504

Email: [ctl\\_terminals@caict.ac.cn](mailto:ctl_terminals@caict.ac.cn), website: [www.caict.ac.cn](http://www.caict.ac.cn)



## **REPORT HISTORY**

<b>Report Number</b>	<b>Revision</b>	<b>Issue Date</b>	<b>Description</b>
I21Z61640-SEM01	Rev.0	2021-9-10	Initial creation of test report

## TABLE OF CONTENT

<b>1 TEST LABORATORY .....</b>	<b>5</b>
1.1 TESTING LOCATION .....	5
1.2 TESTING ENVIRONMENT.....	5
1.3 PROJECT DATA .....	5
1.4 SIGNATURE.....	5
<b>2 STATEMENT OF COMPLIANCE .....</b>	<b>6</b>
<b>3 CLIENT INFORMATION .....</b>	<b>8</b>
3.1 APPLICANT INFORMATION .....	8
3.2 MANUFACTURER INFORMATION .....	8
<b>4 EQUIPMENT UNDER TEST (EUT) AND ANCILLARY EQUIPMENT (AE).....</b>	<b>9</b>
4.1 ABOUT EUT .....	9
4.2 INTERNAL IDENTIFICATION OF EUT USED DURING THE TEST.....	9
4.3 INTERNAL IDENTIFICATION OF AE USED DURING THE TEST .....	9
<b>5 TEST METHODOLOGY .....</b>	<b>10</b>
5.1 APPLICABLE LIMIT REGULATIONS .....	10
5.2 APPLICABLE MEASUREMENT STANDARDS.....	10
<b>6 SPECIFIC ABSORPTION RATE (SAR).....</b>	<b>11</b>
6.1 INTRODUCTION.....	11
6.2 SAR DEFINITION.....	11
<b>7 TISSUE SIMULATING LIQUIDS .....</b>	<b>12</b>
7.1 TARGETS FOR TISSUE SIMULATING LIQUID .....	12
7.2 DIELECTRIC PERFORMANCE .....	12
<b>8 SYSTEM VERIFICATION .....</b>	<b>15</b>
8.1 SYSTEM SETUP.....	15
8.2 SYSTEM VERIFICATION.....	16
<b>9 MEASUREMENT PROCEDURES .....</b>	<b>17</b>
9.1 TESTS TO BE PERFORMED .....	17
9.2 GENERAL MEASUREMENT PROCEDURE.....	18
9.3 WCDMA MEASUREMENT PROCEDURES FOR SAR .....	20
9.4 SAR MEASUREMENT FOR LTE.....	21
9.5 BLUETOOTH & WI-FI MEASUREMENT PROCEDURES FOR SAR .....	23
9.6 POWER DRIFT.....	23
<b>10 AREA SCAN BASED 1-G SAR.....</b>	<b>24</b>
10.1 REQUIREMENT OF KDB.....	24
10.2 FAST SAR ALGORITHMS .....	24

<b>11 CONDUCTED OUTPUT POWER</b> .....	<b>25</b>
11.1 GSM MEASUREMENT RESULT .....	25
11.2 WCDMA MEASUREMENT RESULT.....	28
11.3 LTE MEASUREMENT RESULT .....	30
11.4 WI-FI AND BT MEASUREMENT RESULT .....	48
<b>12 SIMULTANEOUS TX SAR CONSIDERATIONS</b> .....	<b>49</b>
12.1 INTRODUCTION.....	49
12.2 TRANSMIT ANTENNA SEPARATION DISTANCES .....	49
12.3 SAR MEASUREMENT POSITIONS .....	50
12.4 STANDALONE SAR TEST EXCLUSION CONSIDERATIONS .....	50
<b>13 EVALUATION OF SIMULTANEOUS</b> .....	<b>51</b>
<b>14 SAR TEST RESULT</b> .....	<b>52</b>
14.1 SAR RESULTS FOR FAST SAR.....	53
14.2 SAR RESULTS FOR STANDARD PROCEDURE.....	63
14.3 WLAN EVALUATION FOR 2.4G .....	64
14.4 BT EVALUATION.....	66
<b>15 SAR MEASUREMENT VARIABILITY</b> .....	<b>67</b>
<b>16 MEASUREMENT UNCERTAINTY</b> .....	<b>69</b>
16.1 MEASUREMENT UNCERTAINTY FOR NORMAL SAR TESTS (300MHZ~3GHZ) .....	69
16.2 MEASUREMENT UNCERTAINTY FOR NORMAL SAR TESTS (3~6GHZ) .....	70
16.3 MEASUREMENT UNCERTAINTY FOR FAST SAR TESTS (300MHZ~3GHZ) .....	71
16.4 MEASUREMENT UNCERTAINTY FOR FAST SAR TESTS (3~6GHZ).....	72
<b>17 MAIN TEST INSTRUMENTS</b> .....	<b>73</b>
<b>ANNEX A GRAPH RESULTS</b> .....	<b>74</b>
<b>ANNEX B SYSTEM VERIFICATION RESULTS</b> .....	<b>110</b>
<b>ANNEX C SAR MEASUREMENT SETUP</b> .....	<b>117</b>
<b>ANNEX D POSITION OF THE WIRELESS DEVICE IN RELATION TO THE PHANTOM</b> .....	<b>123</b>
<b>ANNEX E EQUIVALENT MEDIA RECIPES</b> .....	<b>126</b>
<b>ANNEX F SYSTEM VALIDATION</b> .....	<b>127</b>
<b>ANNEX G PROBE CALIBRATION CERTIFICATE</b> .....	<b>128</b>
<b>ANNEX H DIPOLE CALIBRATION CERTIFICATE</b> .....	<b>151</b>
<b>ANNEX I SPOT CHECK</b> .....	<b>191</b>
<b>ANNEX J ACCREDITATION CERTIFICATE</b> .....	<b>218</b>

## 1 Test Laboratory

### 1.1 Testing Location

Company Name:	CTTL(Shouxiang)
Address:	No. 51 Shouxiang Science Building, Xueyuan Road, Haidian District, Beijing, P. R. China100191

### 1.2 Testing Environment

Temperature:	18°C~25°C,
Relative humidity:	30%~ 70%
Ground system resistance:	< 0.5 $\Omega$
Ambient noise & Reflection:	< 0.012 W/kg

### 1.3 Project Data

Project Leader:	Qi Dianyuan
Test Engineer:	Lin Xiaojun
Testing Start Date:	September 12, 2020
Testing End Date:	September 1, 2020

### 1.4 Signature



---

Lin Xiaojun

(Prepared this test report)

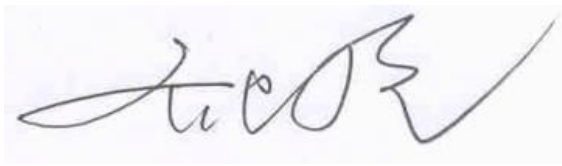

---

Qi Dianyuan

(Reviewed this test report)

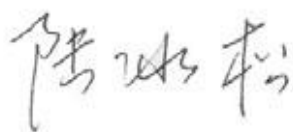

---

Lu Bingsong

Deputy Director of the laboratory

(Approved this test report)

## 2 Statement of Compliance

This EUT is a variant product and the report of original sample is No.I20Z61322-SEM05. We do the spot check on highest value point of the original report for head and body respectively. The results of spot check are presented in the annex I.

The maximum results of SAR found during testing for TCL Communication Ltd. GSM/UMTS/LTE Mobile phone 5007S are as follows:

**Table 2.1: Highest Reported SAR (1g)**

Exposure Configuration	Technology Band	Highest Reported SAR 1g(W/kg)	Equipment Class
Head (Separation Distance 0mm)	GSM 850	0.34	PCE
	PCS 1900	0.04	
	UMTS FDD 5	0.76	
	UMTS FDD 4	0.40	
	UMTS FDD 2	0.15	
	LTE Band 2	0.11	
	LTE Band 5	1.15	
	LTE Band 12	0.53	
	LTE Band 13	0.26	
	LTE Band 66	0.27	
	WLAN 2.4 GHz	0.32	DTS
Hotspot (Separation Distance 10mm)	GSM 850	0.48	PCE
	PCS 1900	0.93	
	UMTS FDD 5	0.19	
	UMTS FDD 4	1.03	
	UMTS FDD 2	1.06	
	LTE Band 2	1.23	
	LTE Band 5	0.37	
	LTE Band 12	0.32	
	LTE Band 13	0.53	
	LTE Band 66	<b>1.28</b>	
	WLAN 2.4 GHz	0.18	DTS
Body-worn (Separation Distance 15mm)	PCS 1900	0.52	PCE
	UMTS FDD 4	0.54	
	UMTS FDD 2	0.65	
	LTE Band 2	0.90	
	LTE Band 66	0.90	

The SAR values found for the Mobile Phone are below the maximum recommended levels of 1.6 W/kg as averaged over any 1g tissue according to the ANSI C95.1-1992.

For body operation, this device has been tested and meets FCC RF exposure guidelines when used with any accessory that contains no metal and which provides a minimum separation distance of 10 mm for hotspot and 15mm for body worn between this device and the body of the user. Use of other accessories may not ensure compliance with FCC RF exposure guidelines.

The EUT battery must be fully charged and checked periodically during the test to ascertain uniform power output.

The measurement together with the test system set-up is described in annex C of this test report. A

detailed description of the equipment under test can be found in chapter 4 of this test report. The highest reported SAR value is obtained at the case of **(Table 2.1)**, and the values are: **1.28 W/kg(1g)**.

**Table 2.2: The sum of reported SAR values for cellular antenna and WiFi**

	Position	Band	Cellular antenna	WiFi	Sum
<b>Highest reported SAR value for Head</b>	Right hand, Touch cheek	LTE B5	1.15	0.32	<b>1.47</b>
<b>Highest reported SAR value for Body</b>	Bottom 10mm	LTE B66	1.28	/	<b>1.28</b>

Note1: we have evaluated and chose the highest value of WiFi 2.4G and 5G in the above table.

Note2: we have evaluated and chose the highest value of body 10mm and 15mm in the above table.

**Table 2.3: The sum of reported SAR values for cellular antenna and BT**

	Position	Band	Cellular antenna	BT	Sum
<b>Maximum reported SAR value for Head</b>	Right hand, Touch cheek	LTE B5	1.15	<0.01 <sup>[1]</sup>	<b>1.15</b>
<b>Maximum reported SAR value for Body</b>	Rear 10mm	LTE B2	1.09	0.23 <sup>[2]</sup>	<b>1.32</b>

[1] – The head SAR of BT is too low to get it, so the “<0.01” is used to indicate the head SAR of BT.

[2] - Estimated SAR for Bluetooth (see the table 13.3)

According to the above tables, the highest sum of reported SAR values is **1.47 W/kg (1g)**. The detail for simultaneous transmission consideration is described in chapter 13.

According to the KDB648474 D04, the UMPC mini-tablet procedures must also be applied to test the SAR of all surfaces and edges with an antenna located at  $\leq 25$  mm from that surface or edge, in direct contact with a flat phantom, for 10-g extremity SAR according to the body-equivalent tissue dielectric parameters in KDB Publication 865664 D01 to address interactive hand use exposure conditions. When hotspot mode applies, 10-g extremity SAR is required only for the surfaces and edges with hotspot mode 1-g reported SAR > 1.2 W/kg

**Table 2.4: 0mm Reported SAR for phablet (10g)**

Exposure Configuration	Technology Band	Highest Reported SAR 10g(W/kg)	Limit 10g (W/kg)
10g extremity SAR (Separation Distance 0mm)	GSM1900	1.32	4.0
	UMTS FDD 4	3.13	4.0
	UMTS FDD 2	2.84	4.0
	LTE Band 2	3.34	4.0
	LTE Band 66	3.46	4.0



### 3 Client Information

#### 3.1 Applicant Information

Company Name:	TCL Communication Ltd.
Address/Post:	5/F, Building 22E, 22 Science Park East Avenue, Hong Kong Science Park, Shatin, NT, Hong Kong
Contact Person:	Gong Zhizhou
E-mail:	zhizhou.gong@tcl.com
Telephone:	0086-755-36611722
Fax:	0086-75536612000-81722

#### 3.2 Manufacturer Information

Company Name:	TCL Communication Ltd.
Address/Post:	5/F, Building 22E, 22 Science Park East Avenue, Hong Kong Science Park, Shatin, NT, Hong Kong
Contact Person:	Gong Zhizhou
E-mail:	zhizhou.gong@tcl.com
Telephone:	0086-755-36611722
Fax:	0086-75536612000-81722



## 4 Equipment Under Test (EUT) and Ancillary Equipment (AE)

### 4.1 About EUT

Description:	GSM/UMTS/LTE Mobile phone
Model name:	5007S
Operating mode(s):	GSM 850/900/1800/1900, UMTS FDD 2/4/5, BT, Wi-Fi LTE Band 2/4/5/12/13/66
Tested Tx Frequency:	825 – 848.8 MHz (GSM 850)
	1850.2 – 1910 MHz (GSM 1900)
	826.4–846.6 MHz (WCDMA 850 Band V)
	1712.4 – 1752.6 MHz (WCDMA 1700 Band IV)
	1852.4–1907.6 MHz (WCDMA1900 Band II)
	1850 – 1910 MHz (LTE Band 2)
	824 – 849 MHz (LTE Band 5)
	699.7 – 715.3 MHz (LTE Band 12)
	779.5 –784.5 MHz (LTE Band 13)
	1710.7 –1779.3 MHz (LTE Band 66)
2412 – 2462 MHz (Wi-Fi 2.4G)	
GPRS/EGPRS Multislot Class:	12
GPRS capability Class:	B
Test device Production information:	Production unit
Device type:	Portable device
Antenna type:	Integrated antenna
Accessories/Body-worn configurations:	Headset
Hotspot mode:	Support

### 4.2 Internal Identification of EUT used during the test

EUT ID*	IMEI	HW	SW Version
EUT1	015794000205311	04	v2F21UZ10
EUT2	015794000205303	04	v2F21UZ10
EUT3	015794000205089	04	v2F21UZ10

\*EUT ID: is used to identify the test sample in the lab internally.

**Note:** It is performed to test SAR with the EUT1 and conducted power with the EUT2&3.

### 4.3 Internal Identification of AE used during the test

AE ID*	Description	Model	SN	Manufacturer
AE1	Battery	TLp034G1	/	BYD

\*AE ID: is used to identify the test sample in the lab internally.

## 5 TEST METHODOLOGY

### 5.1 Applicable Limit Regulations

**ANSI C95.1–1992:** IEEE Standard for Safety Levels with Respect to Human Exposure to Radio Frequency Electromagnetic Fields, 3 kHz to 300 GHz.

It specifies the maximum exposure limit of **1.6 W/kg** as averaged over any 1 gram of tissue for portable devices being used within 20 cm of the user in the uncontrolled environment.

### 5.2 Applicable Measurement Standards

**IEEE 1528–2013:** Recommended Practice for Determining the Peak Spatial-Average Specific Absorption Rate (SAR) in the Human Head from Wireless Communications Devices: Measurement Techniques.

**KDB447498 D01: General RF Exposure Guidance v06:** Mobile and Portable Devices RF Exposure Procedures and Equipment Authorization Policies.

**KDB648474 D04 Handset SAR v01r03:** SAR Evaluation Considerations for Wireless Handsets.

**KDB941225 D01 SAR test for 3G devices v03r01:** SAR Measurement Procedures for 3G Devices

**KDB941225 D05 SAR for LTE Devices v02r05:** SAR Evaluation Considerations for LTE Devices

**KDB941225 D06 Hotspot Mode SAR v02r01:** SAR Evaluation Procedures for Portable Devices with Wireless Router Capabilities

**KDB248227 D01 802.11 Wi-Fi SAR v02r02:** SAR GUIDANCE FOR IEEE 802.11 (Wi-Fi) TRANSMITTERS

**KDB865664 D01 SAR measurement 100 MHz to 6 GHz v01r04:** SAR Measurement Requirements for 100 MHz to 6 GHz.

**KDB865664 D02 RF Exposure Reporting v01r02:** RF Exposure Compliance Reporting and Documentation Considerations

## 6 Specific Absorption Rate (SAR)

### 6.1 Introduction

SAR is related to the rate at which energy is absorbed per unit mass in an object exposed to a radio field. The SAR distribution in a biological body is complicated and is usually carried out by experimental techniques or numerical modeling. The standard recommends limits for two tiers of groups, occupational/controlled and general population/uncontrolled, based on a person's awareness and ability to exercise control over his or her exposure. In general, occupational/controlled exposure limits are higher than the limits for general population/uncontrolled.

### 6.2 SAR Definition

The SAR definition is the time derivative (rate) of the incremental energy ( $dW$ ) absorbed by (dissipated in) an incremental mass ( $dm$ ) contained in a volume element ( $dv$ ) of a given density ( $\rho$ ). The equation description is as below:

$$SAR = \frac{d}{dt} \left( \frac{dW}{dm} \right) = \frac{d}{dt} \left( \frac{dW}{\rho dv} \right)$$

SAR is expressed in units of Watts per kilogram (W/kg)

SAR measurement can be either related to the temperature elevation in tissue by

$$SAR = c \left( \frac{\delta T}{\delta t} \right)$$

Where:  $C$  is the specific heat capacity,  $\delta T$  is the temperature rise and  $\delta t$  is the exposure duration, or related to the electrical field in the tissue by

$$SAR = \frac{\sigma |E|^2}{\rho}$$

Where:  $\sigma$  is the conductivity of the tissue,  $\rho$  is the mass density of tissue and  $E$  is the RMS electrical field strength.

However for evaluating SAR of low power transmitter, electrical field measurement is typically applied.

## 7 Tissue Simulating Liquids

### 7.1 Targets for tissue simulating liquid

Table 7.1: Targets for tissue simulating liquid

Frequency(MHz)	Liquid Type	Conductivity( $\sigma$ )	$\pm 5\%$ Range	Permittivity( $\epsilon$ )	$\pm 5\%$ Range
750	Head	0.89	0.85~0.93	41.94	39.8~44.0
835	Head	0.90	0.86~0.95	41.5	39.4~43.6
1750	Head	1.37	1.30~1.44	40.08	38.1~42.1
1900	Head	1.40	1.33~1.47	40.0	38.0~42.0
2450	Head	1.80	1.71~1.89	39.2	37.2~41.2

### 7.2 Dielectric Performance

Table 7.2: Dielectric Performance of Tissue Simulating Liquid

Measurement Date (yyyy-mm-dd)	Type	Frequency	Permittivity $\epsilon$	Drift (%)	Conductivity $\sigma$ (S/m)	Drift (%)
2020-9-12	Head	750 MHz	41.28	-1.57	0.89	0.00
2020-9-13	Head	835 MHz	40.92	-1.40	0.898	-0.22
2020-9-14	Head	1750 MHz	39.69	-0.97	1.358	-0.88
2020-9-15	Head	1900 MHz	40.74	1.85	1.408	0.57
2020-9-16	Head	2450 MHz	39.19	-0.03	1.836	2.00

Note: The liquid temperature is 22.0°C

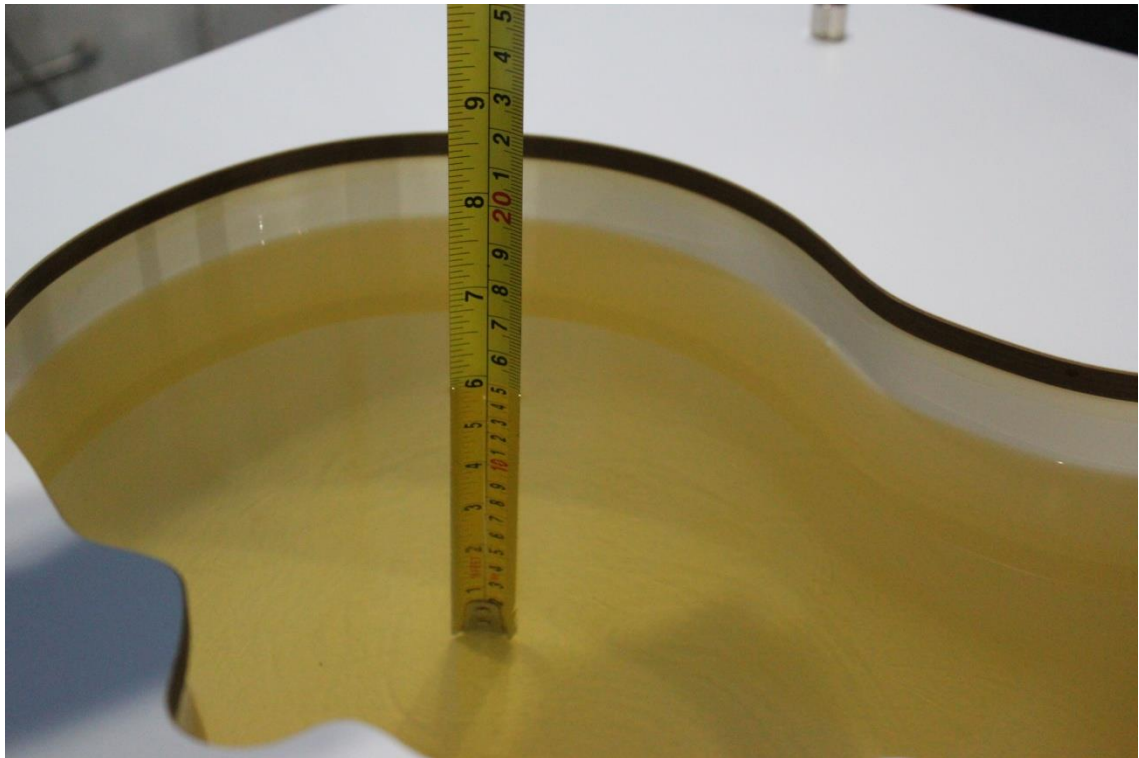

Picture 7-1 Liquid depth in the Head Phantom (750MHz)

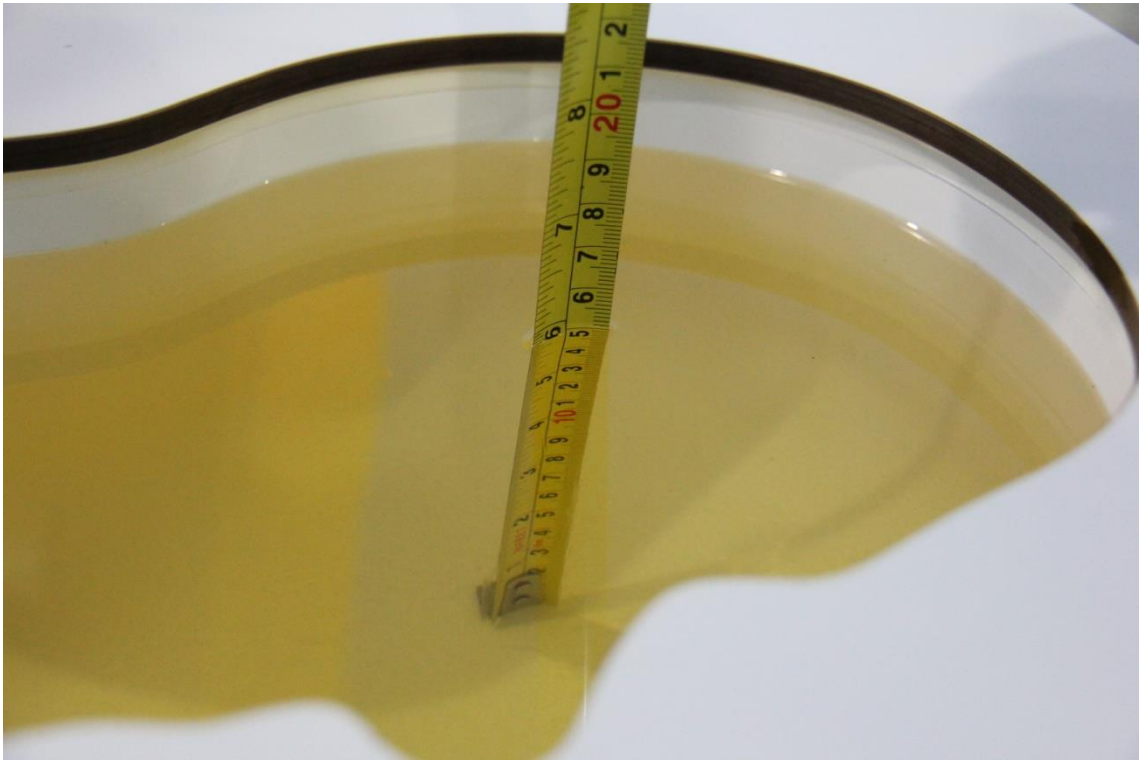

Picture 7-2 Liquid depth in the Head Phantom (835 MHz)

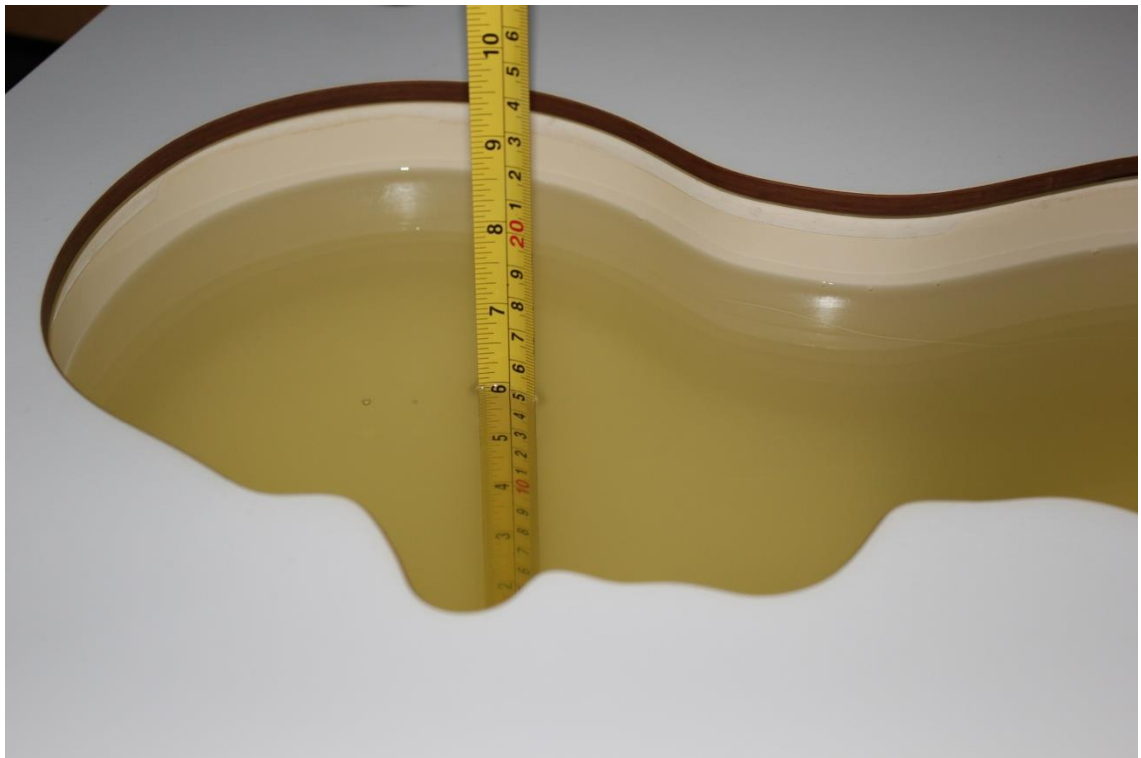

Picture 7-3 Liquid depth in the Head Phantom (1750 MHz)

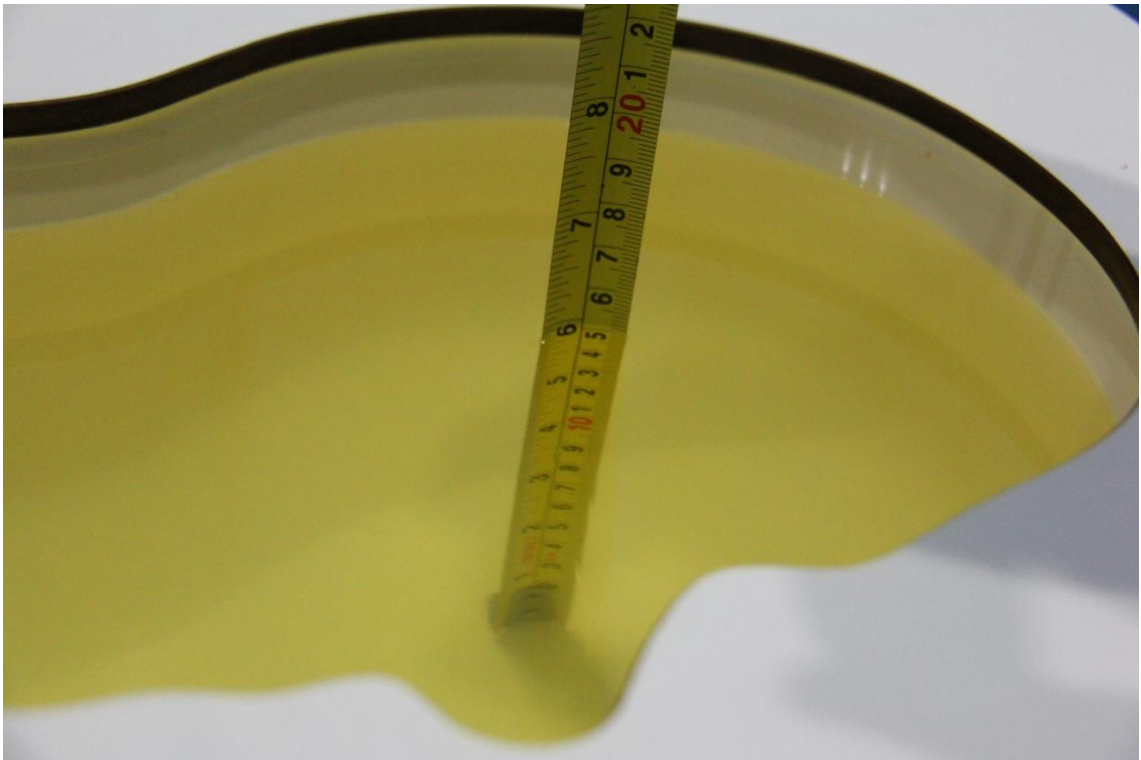

**Picture 7-4 Liquid depth in the Head Phantom (1900 MHz)**

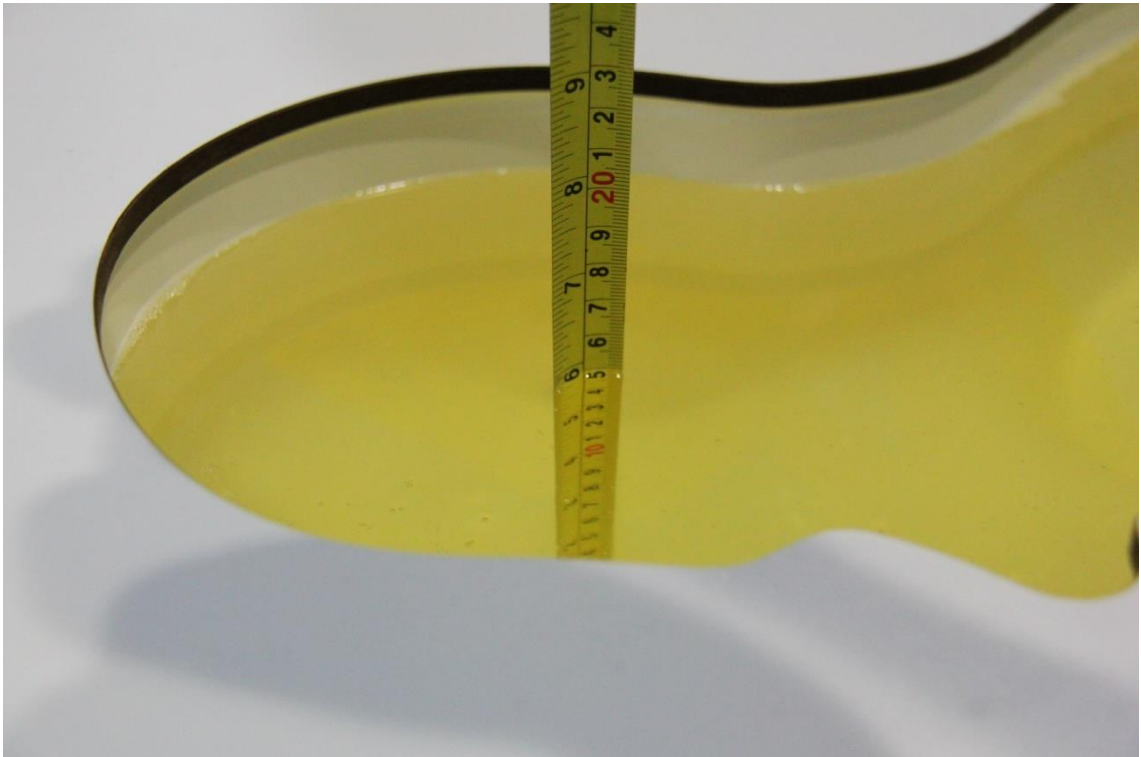

**Picture 7-5 Liquid depth in the Head Phantom (2450MHz)**

## 8 System verification

### 8.1 System Setup

In the simplified setup for system evaluation, the DUT is replaced by a calibrated dipole and the power source is replaced by a continuous wave that comes from a signal generator. The calibrated dipole must be placed beneath the flat phantom section of the SAM twin phantom with the correct distance holder. The distance holder should touch the phantom surface with a light pressure at the reference marking and be oriented parallel to the long side of the phantom. The equipment setup is shown below:

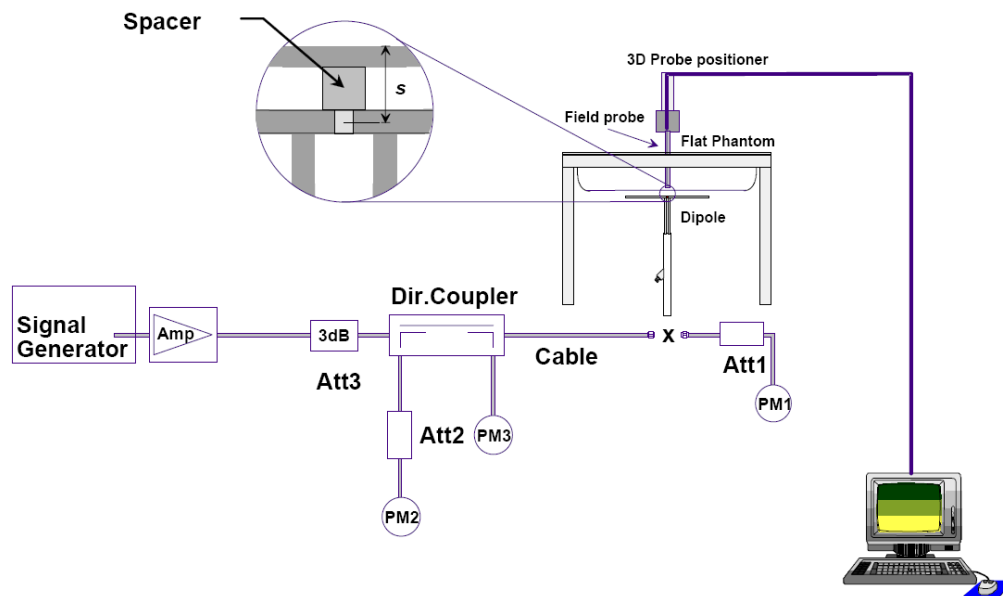

Picture 8.1 System Setup for System Evaluation



Picture 8.2 Photo of Dipole Setup

## 8.2 System Verification

SAR system verification is required to confirm measurement accuracy, according to the tissue dielectric media, probe calibration points and other system operating parameters required for measuring the SAR of a test device. The system verification must be performed for each frequency band and within the valid range of each probe calibration point required for testing the device.

The system verification results are required that the area scan estimated 1-g SAR is within 3% of the zoom scan 1-g SAR. The details are presented in annex B.

**Table 8.1: System Verification of Head**

Measurement Date (yyyy-mm-dd)	Frequency	Target value (W/kg)		Measured value(W/kg)		Deviation	
		10 g Average	1 g Average	10 g Average	1 g Average	10 g Average	1 g Average
2020-9-12	750 MHz	5.53	8.47	5.56	8.32	0.54%	-1.77%
2020-9-13	835 MHz	6.25	9.60	6.36	9.64	1.76%	0.42%
2020-9-14	1750 MHz	19.1	36.5	19.16	36.08	0.31%	-1.15%
2020-9-15	1900 MHz	20.6	39.6	20.64	39.68	0.19%	0.20%
2020-9-16	2450 MHz	24.5	52.5	24.88	52.48	1.55%	-0.04%



## 9 Measurement Procedures

### 9.1 Tests to be performed

In order to determine the highest value of the peak spatial-average SAR of a handset, all device positions, configurations and operational modes shall be tested for each frequency band according to steps 1 to 3 below. A flowchart of the test process is shown in picture 9.1.

**Step 1:** The tests described in 9.2 shall be performed at the channel that is closest to the centre of the transmit frequency band ( $f_c$ ) for:

- a) all device positions (cheek and tilt, for both left and right sides of the SAM phantom, as described in annex D),
- b) all configurations for each device position in a), e.g., antenna extended and retracted, and
- c) all operational modes, e.g., analogue and digital, for each device position in a) and configuration in b) in each frequency band.

If more than three frequencies need to be tested according to 11.1 (i.e.,  $N_c > 3$ ), then all frequencies, configurations and modes shall be tested for all of the above test conditions.

**Step 2:** For the condition providing highest peak spatial-average SAR determined in Step 1, perform all tests described in 9.2 at all other test frequencies, i.e., lowest and highest frequencies. In addition, for all other conditions (device position, configuration and operational mode) where the peak spatial-average SAR value determined in Step 1 is within 3 dB of the applicable SAR limit, it is recommended that all other test frequencies shall be tested as well.

**Step 3:** Examine all data to determine the highest value of the peak spatial-average SAR found in Steps 1 to 2.

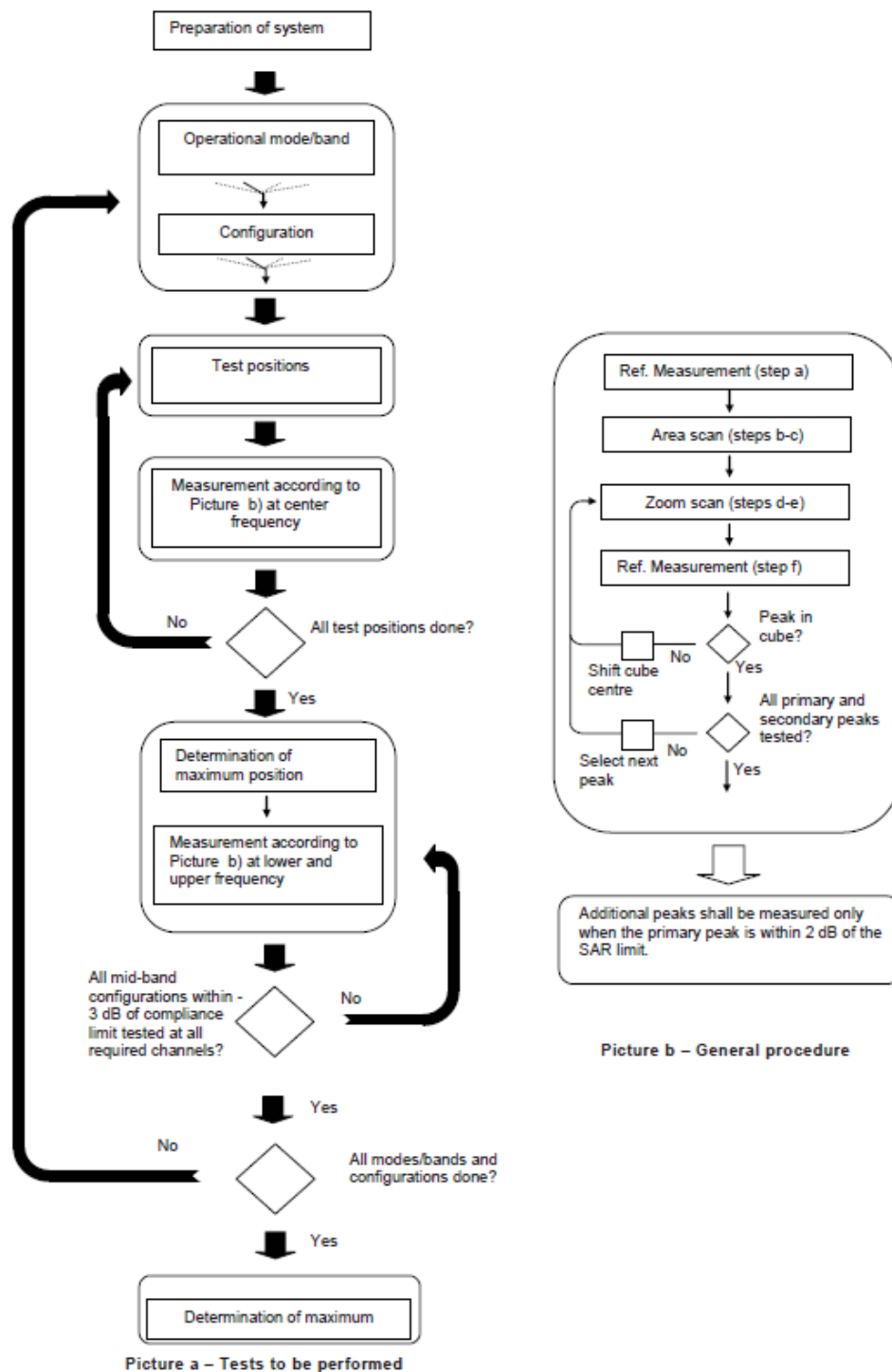

Picture 9.1 Block diagram of the tests to be performed

## 9.2 General Measurement Procedure

The area and zoom scan resolutions specified in the table below must be applied to the SAR measurements and fully documented in SAR reports to qualify for TCB approval. Probe boundary effect error compensation is required for measurements with the probe tip closer than half a probe tip diameter to the phantom surface. Both the probe tip diameter and sensor offset distance must satisfy measurement protocols; to ensure probe boundary effect errors are minimized and the

higher fields closest to the phantom surface can be correctly measured and extrapolated to the phantom surface for computing 1-g SAR. Tolerances of the post-processing algorithms must be verified by the test laboratory for the scan resolutions used in the SAR measurements, according to the reference distribution functions specified in IEEE Std 1528-2003. The results should be documented as part of the system validation records and may be requested to support test results when all the measurement parameters in the following table are not satisfied.

		$\leq 3$ GHz	$> 3$ GHz	
Maximum distance from closest measurement point (geometric center of probe sensors) to phantom surface		$5 \pm 1$ mm	$\frac{1}{2} \cdot \delta \cdot \ln(2) \pm 0.5$ mm	
Maximum probe angle from probe axis to phantom surface normal at the measurement location		$30^\circ \pm 1^\circ$	$20^\circ \pm 1^\circ$	
Maximum area scan spatial resolution: $\Delta x_{Area}$ , $\Delta y_{Area}$		$\leq 2$ GHz: $\leq 15$ mm 2 – 3 GHz: $\leq 12$ mm	3 – 4 GHz: $\leq 12$ mm 4 – 6 GHz: $\leq 10$ mm	
		When the x or y dimension of the test device, in the measurement plane orientation, is smaller than the above, the measurement resolution must be $\leq$ the corresponding x or y dimension of the test device with at least one measurement point on the test device.		
Maximum zoom scan spatial resolution: $\Delta x_{Zoom}$ , $\Delta y_{Zoom}$		$\leq 2$ GHz: $\leq 8$ mm 2 – 3 GHz: $\leq 5$ mm*	3 – 4 GHz: $\leq 5$ mm* 4 – 6 GHz: $\leq 4$ mm*	
Maximum zoom scan spatial resolution, normal to phantom surface	uniform grid: $\Delta z_{Zoom}(n)$	$\leq 5$ mm	3 – 4 GHz: $\leq 4$ mm 4 – 5 GHz: $\leq 3$ mm 5 – 6 GHz: $\leq 2$ mm	
	graded grid	$\Delta z_{Zoom}(1)$ : between 1 <sup>st</sup> two points closest to phantom surface	$\leq 4$ mm	3 – 4 GHz: $\leq 3$ mm 4 – 5 GHz: $\leq 2.5$ mm 5 – 6 GHz: $\leq 2$ mm
		$\Delta z_{Zoom}(n>1)$ : between subsequent points	$\leq 1.5 \cdot \Delta z_{Zoom}(n-1)$	
Minimum zoom scan volume	x, y, z	$\geq 30$ mm	3 – 4 GHz: $\geq 28$ mm 4 – 5 GHz: $\geq 25$ mm 5 – 6 GHz: $\geq 22$ mm	
Note: $\delta$ is the penetration depth of a plane-wave at normal incidence to the tissue medium; see draft standard IEEE P1528-2011 for details. * When zoom scan is required and the <i>reported</i> SAR from the area scan based 1-g SAR estimation procedures of KDB 447498 is $\leq 1.4$ W/kg, $\leq 8$ mm, $\leq 7$ mm and $\leq 5$ mm zoom scan resolution may be applied, respectively, for 2 GHz to 3 GHz, 3 GHz to 4 GHz and 4 GHz to 6 GHz.				

### 9.3 WCDMA Measurement Procedures for SAR

The following procedures are applicable to WCDMA handsets operating under 3GPP Release99, Release 5 and Release 6. The default test configuration is to measure SAR with an established radio link between the DUT and a communication test set using a 12.2kbps RMC (reference measurement channel) configured in Test Loop Mode 1. SAR is selectively confirmed for other physical channel configurations (DPCCH & DPDCH<sub>n</sub>), HSDPA and HSPA (HSUPA/HSDPA) modes according to output power, exposure conditions and device operating capabilities. Both uplink and downlink should be configured with the same RMC or AMR, when required. SAR for Release 5 HSDPA and Release 6 HSPA are measured using the applicable FRC (fixed reference channel) and E-DCH reference channel configurations. Maximum output power is verified according to applicable versions of 3GPP TS 34.121 and SAR must be measured according to these maximum output conditions. When Maximum Power Reduction (MPR) is not implemented according to Cubic Metric (CM) requirements for Release 6 HSPA, the following procedures do not apply.

#### For Release 5 HSDPA Data Devices:

Sub-test	$\beta_c$	$\beta_d$	$\beta_d$ (SF)	$\beta_c/\beta_d$	$\beta_{hs}$	CM/dB
1	2/15	15/15	64	2/15	4/15	0.0
2	12/15	15/15	64	12/15	24/25	1.0
3	15/15	8/15	64	15/8	30/15	1.5
4	15/15	4/15	64	15/4	30/15	1.5

#### For Release 6 HSPA Data Devices

Sub-test	$\beta_c$	$\beta_d$	$\beta_d$ (SF)	$\beta_c/\beta_d$	$\beta_{hs}$	$\beta_{ec}$	$\beta_{ed}$	$\beta_{ed}$ (SF)	$\beta_{ed}$ (codes)	CM (dB)	MPR (dB)	AG Index	E-TFCI
1	11/15	15/15	64	11/15	22/15	209/225	1039/225	4	1	1.5	1.5	20	75
2	6/15	15/15	64	6/15	12/15	12/15	12/15	4	1	1.5	1.5	12	67
3	15/15	9/15	64	15/9	30/15	30/15	$\beta_{ed1}:47/15$ $\beta_{ed2}:47/15$	4	2	1.5	1.5	15	92
4	2/15	15/15	64	2/15	4/15	4/15	56/75	4	1	1.5	1.5	17	71
5	15/15	15/15	64	15/15	24/15	30/15	134/15	4	1	1.5	1.5	21	81

#### Rel.8 DC-HSDPA (Cat 24)

SAR test exclusion for Rel.8 DC-HSDPA must satisfy the SAR test exclusion requirements of Rel.5 HSDPA. SAR test exclusion for DC-HSDPA devices is determined by power measurements according to the H-Set 12, Fixed Reference Channel (FRC) configuration in Table C.8.1.12 of 3GPP TS 34.121-1. A primary and a secondary serving HS-DSCH Cell are required to perform the power measurement and for the results to qualify for SAR test exclusion.

## 9.4 SAR Measurement for LTE

SAR tests for LTE are performed with a base station simulator, Rohde & Schwarz CMW500. Closed loop power control was used so the UE transmits with maximum output power during SAR testing. All powers were measured with the CMW 500.

It is performed for conducted power and SAR based on the KDB941225 D05.

SAR is evaluated separately according to the following procedures for the different test positions in each exposure condition – head, body, body-worn accessories and other use conditions. The procedures in the following subsections are applied separately to test each LTE frequency band.

### 1) QPSK with 1 RB allocation

Start with the largest channel bandwidth and measure SAR for QPSK with 1 RB allocation, using the RB offset and required test channel combination with the highest maximum output power among RB offsets at the upper edge, middle and lower edge of each required test channel. When the reported SAR is  $\leq 0.8$  W/kg, testing of the remaining RB offset configurations and required test channels is not required for 1 RB allocation; otherwise, SAR is required for the remaining required test channels and only for the RB offset configuration with the highest output power for that channel. When the reported SAR of a required test channel is  $> 1.45$  W/kg, SAR is required for all three RB offset configurations for that required test channel.

### 2) QPSK with 50% RB allocation

The procedures required for 1 RB allocation in 1) are applied to measure the SAR for QPSK with 50% RB allocation.

### 3) QPSK with 100% RB allocation

For QPSK with 100% RB allocation, SAR is not required when the highest maximum output power for 100 % RB allocation is less than the highest maximum output power in 50% and 1 RB allocations and the highest reported SAR for 1 RB and 50% RB allocation in 1) and 2) are  $\leq 0.8$  W/kg. Otherwise, SAR is measured for the highest output power channel; and if the reported SAR is  $> 1.45$  W/kg, the remaining required test channels must also be tested.

## TDD test:

TDD testing is performed using guidance from FCC KDB 941225 D05 v02r05 and the SAR test guidance provided in April 2013 TCB works hop notes. TDD is tested at the highest duty factor using UL-DL configuration 0 with special subframe configuration 6 and applying the FDD LTE procedures in KDB 941225 D05 v02r05. SAR testing is performed using the extended cyclic prefix listed in 3GPP TS 36.211.

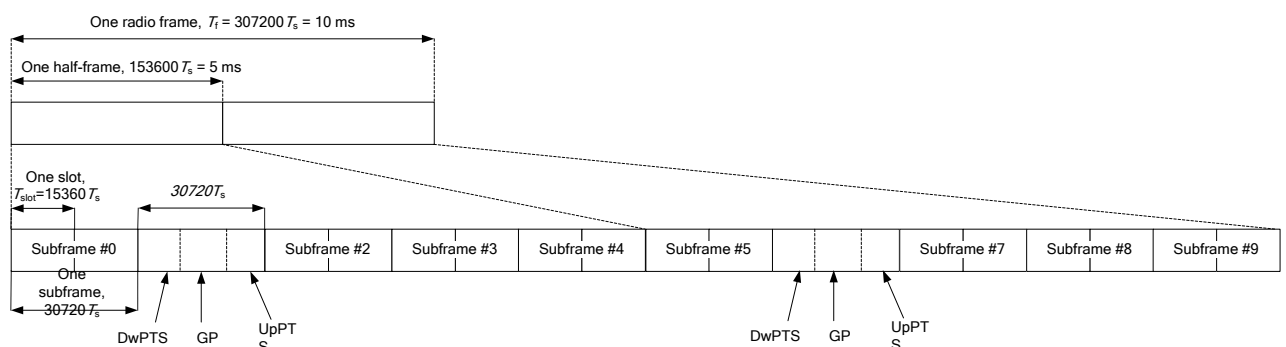

Figure 9.2: Frame structure type 2 (for 5 ms switch-point periodicity)

**Table 9.1: Configuration of special subframe (lengths of DwPTS/GP/UpPTS)**

Special subframe configuration	Normal cyclic prefix in downlink			Extended cyclic prefix in downlink		
	DwPTS	UpPTS		DwPTS	UpPTS	
		Normal cyclic prefix in uplink	Extended cyclic prefix in uplink		Normal cyclic prefix in uplink	Extended cyclic prefix in uplink
0	$6592 \cdot T_s$	$2192 \cdot T_s$	$2560 \cdot T_s$	$7680 \cdot T_s$	$2192 \cdot T_s$	$2560 \cdot T_s$
1	$19760 \cdot T_s$			$20480 \cdot T_s$		
2	$21952 \cdot T_s$			$23040 \cdot T_s$		
3	$24144 \cdot T_s$			$25600 \cdot T_s$		
4	$26336 \cdot T_s$	$4384 \cdot T_s$	$5120 \cdot T_s$	$7680 \cdot T_s$	$4384 \cdot T_s$	$5120 \cdot T_s$
5	$6592 \cdot T_s$			$20480 \cdot T_s$		
6	$19760 \cdot T_s$			$23040 \cdot T_s$		
7	$21952 \cdot T_s$			$12800 \cdot T_s$		
8	$24144 \cdot T_s$			-		
9	$13168 \cdot T_s$	-	-	-	-	-

**Table 9.2: Uplink-downlink configurations**

Uplink-downlink configuration	Downlink-to-Uplink Switch-point periodicity	Subframe number										
		0	1	2	3	4	5	6	7	8	9	
0	5 ms	D	S	U	U	U	D	S	U	U	U	
1	5 ms	D	S	U	U	D	D	S	U	U	D	
2	5 ms	D	S	U	D	D	D	S	U	D	D	
3	10 ms	D	S	U	U	U	D	D	D	D	D	
4	10 ms	D	S	U	U	D	D	D	D	D	D	
5	10 ms	D	S	U	D	D	D	D	D	D	D	
6	5 ms	D	S	U	U	U	D	S	U	U	D	

Duty factor is calculated by:

$$\begin{aligned}
 \text{Duty factor} &= \text{uplink frame} \cdot 6 + \text{UpPTS} \cdot 2 / \text{one frame length} \\
 &= (30720 \cdot T_s \cdot 6 + 5120 \cdot T_s \cdot 2) / 307200 \cdot T_s \\
 &= 0.633
 \end{aligned}$$

According to the KDB 447498 D01, SAR should be evaluated at more than 3 frequencies for devices supporting transmit bands wider than 100MHz. Oct.2014 FCC-TCB conference notes (Dec. 2014 rev.) specifies the 5 test channels to use for 3GPP band 41 SAR evaluation.

## 9.5 Bluetooth & Wi-Fi Measurement Procedures for SAR

Normal network operating configurations are not suitable for measuring the SAR of 802.11 transmitters in general. Unpredictable fluctuations in network traffic and antenna diversity conditions can introduce undesirable variations in SAR results. The SAR for these devices should be measured using chipset based test mode software to ensure that the results are consistent and reliable.

Chipset based test mode software is hardware dependent and generally varies among manufacturers. The device operating parameters established in a test mode for SAR measurements must be identical to those programmed in production units, including output power levels, amplifier gain settings and other RF performance tuning parameters. The test frequencies should correspond to actual channel frequencies defined for domestic use. SAR for devices with switched diversity should be measured with only one antenna transmitting at a time during each SAR measurement, according to a fixed modulation and data rate. The same data pattern should be used for all measurements.

## 9.6 Power Drift

To control the output power stability during the SAR test, DASY4 system calculates the power drift by measuring the E-field at the same location at the beginning and at the end of the measurement for each test position. These drift values can be found in section 14 labeled as: (Power Drift [dB]). This ensures that the power drift during one measurement is within 5%.

## 10 Area Scan Based 1-g SAR

### 10.1 Requirement of KDB

According to the KDB447498 D01 v05, when the implementation is based the specific polynomial fit algorithm as presented at the 29th Bioelectromagnetics Society meeting (2007) and the estimated 1-gSAR is  $\leq 1.2$  W/kg, a zoom scan measurement is not required provided it is also not needed for any other purpose; for example, if the peak SAR location required for simultaneous transmission SAR test exclusion can be determined accurately by the SAR system or manually to discriminate between distinctive peaks and scattered noisy SAR distributions from area scans.

There must not be any warning or alert messages due to various measurement concerns identified by the SAR system; for example, noise in measurements, peaks too close to scan boundary, peaks are too sharp, spatial resolution and uncertainty issues etc. The SAR system verification must also demonstrate that the area scan estimated 1-g SAR is within 3% of the zoom scan 1-g SAR (See Annex B). When all the SAR results for each exposure condition in a frequency band and wireless mode are based on estimated 1-g SAR, the 1-g SAR for the highest SAR configuration must be determined by a zoom scan.

### 10.2 Fast SAR Algorithms

The approach is based on the area scan measurement applying a frequency dependent attenuation parameter. This attenuation parameter was empirically determined by analyzing a large number of phones. The MOTOROLA FAST SAR was developed and validated by the MOTOROLA Research Group in Ft. Lauderdale.

In the initial study, an approximation algorithm based on Linear fit was developed. The accuracy of the algorithm has been demonstrated across a broad frequency range (136-2450 MHz) and for both 1- and 10-g averaged SAR using a sample of 264 SAR measurements from 55 wireless handsets. For the sample size studied, the root-mean-squared errors of the algorithm are 1.2% and 5.8% for 1- and 10-g averaged SAR, respectively. The paper describing the algorithm in detail is expected to be published in August 2004 within the Special Issue of Transactions on MTT.

In the second step, the same research group optimized the fitting algorithm to an Polynomial fit whereby the frequency validity was extended to cover the range 30-6000MHz. Details of this study can be found in the BEMS 2007 Proceedings.

Both algorithms are implemented in DASY software.



## 11 Conducted Output Power

For Main antenna, there are two sets of tune-up power, Normal power and Low power, used for different use cases for GSM1900, W1700/1900 and LTE Band 2/66. Normal power status is applied for head test and body worn test of above bands. Low power status is applied for hotspot test of above bands. For other bands, Normal power status is applied for both head and body test.

### 11.1 GSM Measurement result

During the process of testing, the EUT was controlled via Agilent Digital Radio Communication tester (E5515C) to ensure the maximum power transmission and proper modulation. This result contains conducted output power for the EUT. In all cases, the measured peak output power should be greater and within 5% than EMI measurement.

#### Normal Power

**Table 11.1-1: The conducted power measurement results for GSM, GPRS and EGPRS**

GSM 850 Speech (GMSK)	Measured Power (dBm)			Tune up	calculation	Averaged Power (dBm)		
	251	190	128			251	190	128
1 Txslot	32.10	32.11	32.09	33.30	/	/	/	/
GSM 850 GPRS (GMSK)	Measured Power (dBm)				calculation	Averaged Power (dBm)		
	251	190	128			251	190	128
1 Txslot	32.09	32.07	31.86	33.30	-9.03	23.06	23.04	22.83
2 Txslots	<b>29.77</b>	<b>29.72</b>	<b>29.48</b>	<b>30.50</b>	<b>-6.02</b>	<b>23.75</b>	<b>23.70</b>	<b>23.46</b>
3Txslots	27.73	27.65	27.35	28.50	-4.26	23.47	23.39	23.09
4 Txslots	26.39	26.27	25.90	27.50	-3.01	23.38	23.26	22.89
GSM 850 EGPRS (GMSK)	Measured Power (dBm)				calculation	Averaged Power (dBm)		
	251	190	128			251	190	128
1 Txslot	32.04	31.99	31.78	33.30	-9.03	23.01	22.96	22.75
2 Txslots	29.71	29.64	29.40	30.50	-6.02	23.69	23.62	23.38
3Txslots	27.68	27.58	27.28	28.50	-4.26	23.42	23.32	23.02
4 Txslots	26.33	26.19	25.83	27.50	-3.01	23.32	23.18	22.82
GSM 850 EGPRS (8PSK)	Measured Power (dBm)				calculation	Averaged Power (dBm)		
	251	190	128			251	190	128
1 Txslot	25.61	25.62	25.50	26.80	-9.03	16.58	16.59	16.47
2 Txslots	23.60	23.72	23.63	25.50	-6.02	17.58	17.70	17.61
3Txslots	22.35	22.49	22.56	24.00	-4.26	18.09	18.23	18.30
4 Txslots	20.62	20.87	20.76	22.50	-3.01	17.61	17.86	17.75
PCS1900 Speech (GMSK)	Measured Power (dBm)			Tune up	calculation	Averaged Power (dBm)		
	810	661	512			810	661	512
1 Txslot	28.93	29.02	29.16	29.50	/	/	/	/
PCS1900 GPRS (GMSK)	Measured Power (dBm)				calculation	Averaged Power (dBm)		
	810	661	512			810	661	512
1 Txslot	28.80	28.87	29.01	29.50	-9.03	19.77	19.84	19.98
<b>2 Txslots</b>	<b>27.10</b>	<b>27.11</b>	<b>27.25</b>	<b>27.80</b>	<b>-6.02</b>	<b>21.08</b>	<b>21.09</b>	<b>21.23</b>

3Txslots	24.69	24.67	24.76	25.30	-4.26	20.43	20.41	20.50
4 Txslots	23.64	23.62	23.73	24.30	-3.01	20.63	20.61	20.72
PCS1900 EGPRS (GMSK)	Measured Power (dBm)				calculation	Averaged Power (dBm)		
	810	661	512			810	661	512
1 Txslot	28.81	28.87	29.01	29.50	-9.03	19.78	19.84	19.98
<b>2 Txslots</b>	27.11	27.11	27.25	27.80	-6.02	21.09	21.09	21.23
3Txslots	24.70	24.67	24.76	25.30	-4.26	20.44	20.41	20.50
4 Txslots	23.65	23.62	23.73	24.30	-3.01	20.64	20.61	20.72
PCS1900 EGPRS (8PSK)	Measured Power (dBm)				calculation	Averaged Power (dBm)		
	810	661	512			810	661	512
1 Txslot	25.34	25.18	25.23	25.80	-9.03	16.31	16.15	16.20
2 Txslots	23.18	23.03	23.30	23.80	-6.02	17.16	17.01	17.28
3Txslots	21.92	21.98	21.90	22.50	-4.26	17.66	17.72	17.64
4 Txslots	20.86	20.64	20.67	21.30	-3.01	17.85	17.63	17.66

## NOTES:

## 1) Division Factors

To average the power, the division factor is as follows:

1TX-slot = 1 transmit time slot out of 8 time slots=> conducted power divided by (8/1) => -9.03dB

2TX-slots = 2 transmit time slots out of 8 time slots=> conducted power divided by (8/2) => -6.02dB

3TX-slots = 3 transmit time slots out of 8 time slots=> conducted power divided by (8/3) => -4.26dB

4TX-slots = 4 transmit time slots out of 8 time slots=> conducted power divided by (8/4) => -3.01dB

**According to the conducted power as above, the body measurements are performed with 2Txslots for GSM850 and GSM1900.**

**Low Power**
**Table 11.1-2: The conducted power measurement results for GSM, GPRS and EGPRS**

PCS1900 GPRS (GMSK)	Measured Power (dBm)				calculation	Averaged Power (dBm)		
	810	661	512			810	661	512
1 Txslot	26.89	26.89	27.00	27.50	-9.03	17.86	17.86	17.97
2 Txslots	24.70	24.66	24.75	25.30	-6.02	18.68	18.64	18.73
3Txslots	<b>22.97</b>	<b>22.91</b>	<b>23.01</b>	<b>23.80</b>	<b>-4.26</b>	<b>18.71</b>	<b>18.65</b>	<b>18.75</b>
4 Txslots	21.61	21.60	21.72	22.30	-3.01	18.60	18.59	18.71
PCS1900 EGPRS (GMSK)	Measured Power (dBm)				calculation	Averaged Power (dBm)		
	810	661	512			810	661	512
1 Txslot	26.97	26.97	27.09	27.50	-9.03	17.94	17.94	18.06
2 Txslots	24.77	24.73	24.83	25.30	-6.02	18.75	18.71	18.81
3Txslots	23.03	22.98	23.10	23.80	-4.26	18.77	18.72	18.84
4 Txslots	21.67	21.66	21.81	22.30	-3.01	18.66	18.65	18.80
PCS1900 EGPRS (8PSK)	Measured Power (dBm)				calculation	Averaged Power (dBm)		
	810	661	512			810	661	512
1 Txslot	23.35	23.29	23.19	24.00	-9.03	14.32	14.26	14.16
2 Txslots	21.18	20.80	20.79	21.80	-6.02	15.16	14.78	14.77
3Txslots	19.55	19.31	19.49	20.00	-4.26	15.29	15.05	15.23
4 Txslots	18.07	17.87	17.91	18.50	-3.01	15.06	14.86	14.90

**NOTES:**

1) Division Factors

To average the power, the division factor is as follows:

1TX-slot = 1 transmit time slot out of 8 time slots=&gt; conducted power divided by (8/1) =&gt; -9.03dB

2TX-slots = 2 transmit time slots out of 8 time slots=&gt; conducted power divided by (8/2) =&gt; -6.02dB

3TX-slots = 3 transmit time slots out of 8 time slots=&gt; conducted power divided by (8/3) =&gt; -4.26dB

4TX-slots = 4 transmit time slots out of 8 time slots=&gt; conducted power divided by (8/4) =&gt; -3.01dB

**According to the conducted power as above, the body measurements are performed with 3Txslots for GSM1900.**

## 11.2 WCDMA Measurement result

Normal power

**Table 11.2-1: The conducted Power for WCDMA**

Item	band	FDDV result			
	ARFCN	4233 (846.6MHz)	4182 (836.4MHz)	4132 (8246.4MHz)	Tune up
WCDMA	\	23.18	23.22	23.20	24.00
HSUPA	1	20.13	20.19	20.18	21.00
	2	20.09	20.16	20.17	21.00
	3	21.07	21.16	21.17	22.00
	4	19.59	19.67	19.69	20.80
	5	21.06	21.14	21.16	22.00
DC-HSDPA	1	22.06	22.14	22.12	23.00
	2	22.07	22.08	22.11	23.00
	3	21.52	21.64	21.61	22.50
	4	21.51	21.59	21.57	22.50
Item	band	FDDIV result			
	ARFCN	1513 (1752.6MHz)	1412 (1732.4MHz)	1312 (1712.4MHz)	
WCDMA	\	22.78	22.66	22.58	23.50
HSUPA	1	19.87	19.81	19.77	20.80
	2	19.86	19.80	19.75	20.80
	3	20.86	20.83	20.74	21.80
	4	19.36	19.33	19.28	20.30
	5	20.84	20.81	20.75	21.80
DC-HSDPA	1	21.86	21.83	21.78	22.80
	2	21.78	21.78	21.72	22.80
	3	21.31	21.30	21.27	22.30
	4	21.36	21.35	21.30	22.30
Item	band	FDDII result			
	ARFCN	9538 (1907.6MHz)	9400 (1880MHz)	9262 (1852.4MHz)	
WCDMA	\	22.86	22.80	22.79	23.50
HSUPA	1	19.86	19.79	19.82	20.80
	2	19.82	19.78	19.76	20.80
	3	20.8	20.74	20.76	21.80
	4	19.34	19.27	19.29	20.30
	5	20.75	20.71	20.74	21.80
DC-HSDPA	1	21.78	21.79	21.80	22.80
	2	21.73	21.76	21.77	22.80
	3	21.31	21.37	21.36	22.30
	4	21.35	21.40	21.43	22.30

Low power

**Table 11.2-2: The conducted Power for WCDMA**

Item	band	FDDIV result			
	ARFCN	1513 (1752.6MHz)	1412 (1732.4MHz)	1312 (1712.4MHz)	
WCDMA	\	19.75	19.70	19.69	20.50
HSUPA	1	17.92	17.84	17.77	18.80
	2	17.95	17.86	17.81	18.80
	3	18.91	18.83	18.74	19.80
	4	17.42	17.39	17.32	18.30
	5	18.94	18.86	18.80	19.80
DC-HSDPA	1	18.92	18.90	18.88	19.80
	2	18.9	18.83	18.85	19.80
	3	18.36	18.21	18.19	19.30
	4	18.33	18.18	18.23	19.30
Item	band	FDDII result			
	ARFCN	9538 (1907.6MHz)	9400 (1880MHz)	9262 (1852.4MHz)	
WCDMA	\	19.27	19.18	19.18	20.00
HSUPA	1	17.38	17.36	17.37	18.30
	2	17.35	17.30	17.29	18.30
	3	18.37	18.32	18.35	19.30
	4	16.91	16.87	16.83	17.80
	5	18.38	18.33	18.32	19.30
DC-HSDPA	1	18.48	18.43	18.51	19.30
	2	18.44	18.40	18.48	19.30
	3	17.79	17.89	17.86	18.80
	4	17.84	17.83	17.85	18.80

### 11.3 LTE Measurement result

**Table 13.3-1: Maximum Power Reduction (MPR) for LTE**

Modulation	Channel bandwidth / Transmission bandwidth configuration [RB]						MPR (dB)
	1.4	3	5	10	15	20	
	MHz	MHz	MHz	MHz	MHz	MHz	
QPSK	> 5	> 4	> 8	> 12	> 16	> 18	1
16 QAM	≤ 5	≤ 4	≤ 8	≤ 12	≤ 16	≤ 18	1
16 QAM	> 5	> 4	> 8	> 12	> 16	> 18	2

**Table 13.3-2: Maximum Power Reduction (MPR) for LTE Band7/41 on Low power**

Modulation	Channel bandwidth / Transmission bandwidth configuration [RB]						MPR (dB)
	1.4	3	5	10	15	20	
	MHz	MHz	MHz	MHz	MHz	MHz	
QPSK	> 5	> 4	> 8	> 12	> 16	> 18	0
16 QAM	≤ 5	≤ 4	≤ 8	≤ 12	≤ 16	≤ 18	0
16 QAM	> 5	> 4	> 8	> 12	> 16	> 18	0

**Table 13.3-3: The tune up for LTE – Normal Power**

Band	Tune up
LTE Band 2	23.3
LTE Band 5	23.3
LTE Band 12	23.3
LTE Band 13	23.3
LTE Band 66	23.3

**Table 13.3-4: The tune up for LTE – Low Power**

Band	Tune up
LTE Band 2	19.8
LTE Band 66	20.3

## Normal power

Table 11.3-1: The conducted Power for LTE

Band 2					
Bandwidth (MHz)	RB allocation RB offset (Start RB)	Frequency (MHz)	QPSK	16QAM	
			Actual output power (dBm)	Actual output power (dBm)	
1.4 MHz	1RB High (5)	1909.3	22.36	21.39	
		1880	22.30	21.32	
		1850.7	22.39	21.75	
	1RB Middle (3)	1909.3	22.59	21.54	
		1880	22.46	21.46	
		1850.7	22.53	21.90	
	1RB Low (0)	1909.3	22.35	21.38	
		1880	22.26	21.32	
		1850.7	22.38	21.74	
	3RB High (3)	1909.3	22.46	21.60	
		1880	22.35	21.36	
		1850.7	22.46	21.68	
	3RB Middle (1)	1909.3	22.49	21.65	
		1880	22.38	21.39	
		1850.7	22.54	21.69	
	3RB Low (0)	1909.3	22.40	21.60	
		1880	22.31	21.34	
		1850.7	22.48	21.68	
	6RB (0)	1909.3	21.51	20.62	
		1880	21.34	20.47	
		1850.7	21.49	20.34	
	3 MHz	1RB High (14)	1908.5	22.39	21.39
			1880	22.31	21.18
			1851.5	22.44	21.79
		1RB Middle (7)	1908.5	22.57	21.58
			1880	22.46	21.34
			1851.5	22.58	21.91
1RB Low (0)		1908.5	22.51	21.48	
		1880	22.27	21.23	
		1851.5	22.41	21.77	
8RB High (7)		1908.5	21.47	20.46	
		1880	21.31	20.45	
		1851.5	21.37	20.54	
8RB Middle (4)		1908.5	21.53	20.52	
		1880	21.37	20.50	
		1851.5	21.46	20.57	
8RB Low (0)		1908.5	21.54	20.56	
		1880	21.37	20.46	
		1851.5	21.43	20.54	
15RB (0)		1908.5	21.53	20.42	
		1880	21.34	20.38	
		1851.5	21.41	20.45	

5 MHz	1RB High (24)	1907.5	22.35	21.38
		1880	22.28	21.42
		1852.5	22.28	21.83
	1RB Middle (12)	1907.5	22.65	21.70
		1880	22.51	21.62
		1852.5	22.55	22.07
	1RB Low (0)	1907.5	22.41	21.42
		1880	22.28	21.35
		1852.5	22.29	21.79
	12RB High (13)	1907.5	21.28	20.34
		1880	21.22	20.30
		1852.5	21.52	20.52
	12RB Middle (6)	1907.5	21.51	20.56
		1880	21.35	20.43
		1852.5	21.47	20.61
	12RB Low (0)	1907.5	21.50	20.49
		1880	21.28	20.38
		1852.5	21.40	20.55
25RB (0)	1907.5	21.41	20.37	
	1880	21.27	20.33	
	1852.5	21.40	20.47	
10 MHz	1RB High (49)	1905	22.35	21.33
		1880	22.23	21.20
		1855	22.33	21.66
	1RB Middle (24)	1905	22.62	21.49
		1880	22.35	21.28
		1855	22.55	21.80
	1RB Low (0)	1905	22.36	21.37
		1880	22.23	21.12
		1855	22.39	21.72
	25RB High (25)	1905	21.27	20.36
		1880	21.20	20.27
		1855	21.48	20.50
	25RB Middle (12)	1905	21.46	20.55
		1880	21.31	20.36
		1855	21.43	20.50
	25RB Low (0)	1905	21.42	20.51
		1880	21.34	20.36
		1855	21.32	20.46
50RB (0)	1905	21.35	20.38	
	1880	21.29	20.31	
	1855	21.39	20.44	
15 MHz	1RB High (74)	1902.5	22.31	21.59
		1880	22.20	21.63
		1857.5	22.23	21.17
	1RB Middle (37)	1902.5	22.44	21.73
		1880	22.29	21.64
		1857.5	22.30	21.25



	1RB Low (0)	1902.5	22.37	21.72
		1880	22.21	21.50
		1857.5	22.25	21.22
	36RB High (38)	1902.5	21.46	20.42
		1880	21.25	20.21
		1857.5	21.39	20.37
	36RB Middle (19)	1902.5	21.54	20.52
		1880	21.34	20.28
		1857.5	21.39	20.40
	36RB Low (0)	1902.5	21.45	20.44
		1880	21.36	20.30
		1857.5	21.34	20.34
75RB (0)	1902.5	21.41	20.44	
	1880	21.32	20.28	
	1857.5	21.40	20.40	
20 MHz	1RB High (99)	1900	22.11	21.50
		1880	22.04	21.46
		1860	22.03	21.54
	1RB Middle (50)	1900	22.61	21.95
		1880	22.43	21.74
		1860	22.46	21.97
	1RB Low (0)	1900	22.08	21.57
		1880	22.08	21.34
		1860	22.13	21.63
	50RB High (50)	1900	21.31	20.33
		1880	21.19	20.17
		1860	21.36	20.43
	50RB Middle (25)	1900	21.42	20.44
		1880	21.31	20.30
		1860	21.37	20.38
	50RB Low (0)	1900	21.38	20.42
		1880	21.33	20.32
		1860	21.31	20.35
	100RB (0)	1900	21.35	20.37
		1880	21.26	20.31
		1860	21.33	20.39

Band 5					
Bandwidth (MHz)	RB allocation	Frequency (MHz)	QPSK	16QAM	
	RB offset (Start RB)		Actual output power (dBm)	Actual output power (dBm)	
1.4 MHz	1RB High (5)	848.3	22.66	21.49	
		836.5	22.67	21.53	
		824.7	22.58	21.52	
	1RB Middle (3)	848.3	22.67	21.50	
		836.5	22.67	21.54	
		824.7	22.60	21.52	
	1RB Low (0)	848.3	22.71	21.53	
		836.5	22.70	21.59	
		824.7	22.61	21.55	
	3RB High (3)	848.3	22.73	21.96	
		836.5	22.75	22.00	
		824.7	22.52	21.95	
	3RB Middle (1)	848.3	22.74	21.94	
		836.5	22.74	22.02	
		824.7	22.67	21.97	
	3RB Low (0)	848.3	22.73	21.97	
		836.5	22.75	22.03	
		824.7	22.67	21.98	
	6RB (0)	848.3	21.72	20.74	
		836.5	21.72	20.79	
		824.7	21.62	20.71	
	3 MHz	1RB High (14)	847.5	22.66	21.65
			836.5	22.66	21.83
			825.5	22.68	21.56
1RB Middle (7)		847.5	22.84	21.61	
		836.5	22.60	21.88	
		825.5	22.66	21.57	
1RB Low (0)		847.5	22.71	21.65	
		836.5	22.67	21.89	
		825.5	22.67	21.61	
8RB High (7)		847.5	21.80	20.72	
		836.5	21.79	20.68	
		825.5	21.76	20.82	
8RB Middle (4)		847.5	21.76	20.70	
		836.5	21.76	20.74	
		825.5	21.75	20.84	
8RB Low (0)		847.5	21.77	20.72	
		836.5	21.79	20.75	
		825.5	21.79	20.86	
15RB (0)		847.5	21.74	20.61	
		836.5	21.74	20.73	
		825.5	21.74	20.79	
5 MHz		1RB High (24)	846.5	22.58	21.64
			836.5	22.71	21.75
			826.5	22.68	22.21

	1RB Middle (12)	846.5	22.81	21.86	
		836.5	22.91	21.96	
		826.5	22.90	21.93	
	1RB Low (0)	846.5	22.58	21.63	
		836.5	22.70	21.74	
		826.5	22.63	22.14	
	12RB High (13)	846.5	21.58	20.62	
		836.5	21.72	20.75	
		826.5	21.79	20.92	
	12RB Middle (6)	846.5	21.71	20.73	
		836.5	21.76	20.82	
		826.5	21.83	20.99	
	12RB Low (0)	846.5	21.62	20.69	
		836.5	21.70	20.76	
		826.5	21.68	20.83	
	25RB (0)	846.5	21.61	20.57	
		836.5	21.73	20.76	
		826.5	21.74	20.84	
	10 MHz	1RB High (49)	844	22.63	21.55
			836.5	22.74	22.06
			829	22.71	21.73
		1RB Middle (24)	844	22.68	21.62
			836.5	22.80	22.15
			829	22.78	21.85
1RB Low (0)		844	22.67	21.61	
		836.5	22.75	22.08	
		829	22.66	21.74	
25RB High (25)		844	21.60	20.66	
		836.5	21.77	20.80	
		829	21.75	20.87	
25RB Middle (12)		844	21.66	20.71	
		836.5	21.73	20.78	
		829	21.79	20.92	
25RB Low (0)		844	21.63	20.69	
		836.5	21.80	20.82	
		829	21.73	20.83	
50RB (0)		844	21.66	20.64	
		836.5	21.79	20.83	
		829	21.73	20.77	

Band 12					
Bandwidth (MHz)	RB allocation	Frequency (MHz)	QPSK	16QAM	
	RB offset (Start RB)		Actual output power (dBm)	Actual output power (dBm)	
1.4 MHz	1RB High (5)	715.3	22.45	21.46	
		707.5	22.48	21.51	
		699.7	22.49	21.77	
	1RB Middle (3)	715.3	22.59	21.66	
		707.5	22.66	21.70	
		699.7	22.67	21.93	
	1RB Low (0)	715.3	22.44	21.45	
		707.5	22.49	21.51	
		699.7	22.46	21.75	
	3RB High (3)	715.3	22.56	21.63	
		707.5	22.47	21.52	
		699.7	22.52	21.65	
	3RB Middle (1)	715.3	22.62	21.69	
		707.5	22.55	21.57	
		699.7	22.53	21.65	
	3RB Low (0)	715.3	22.57	21.66	
		707.5	22.53	21.51	
		699.7	22.49	21.62	
	6RB (0)	715.3	21.57	20.78	
		707.5	21.56	20.68	
		699.7	21.50	20.43	
	3 MHz	1RB High (14)	714.5	22.49	21.42
			707.5	22.50	21.38
			700.5	22.55	21.83
1RB Middle (7)		714.5	22.63	21.65	
		707.5	22.60	21.53	
		700.5	22.64	21.95	
1RB Low (0)		714.5	22.54	21.57	
		707.5	22.45	21.39	
		700.5	22.46	21.82	
8RB High (7)		714.5	21.52	20.59	
		707.5	21.49	20.63	
		700.5	21.47	20.56	
8RB Middle (4)		714.5	21.61	20.65	
		707.5	21.56	20.68	
		700.5	21.53	20.62	
8RB Low (0)		714.5	21.55	20.60	
		707.5	21.49	20.63	
		700.5	21.47	20.59	
15RB (0)		714.5	21.50	20.51	
		707.5	21.46	20.52	
		700.5	21.44	20.54	
5 MHz		1RB High (24)	713.5	22.38	21.48
			707.5	22.43	21.56
			701.5	22.42	21.90

	1RB Middle (12)	713.5	22.65	21.71	
		707.5	22.57	21.77	
		701.5	22.60	22.09	
	1RB Low (0)	713.5	22.42	21.52	
		707.5	22.37	21.51	
		701.5	22.35	21.80	
	12RB High (13)	713.5	21.46	20.52	
		707.5	21.52	20.58	
		701.5	21.46	20.59	
	12RB Middle (6)	713.5	21.55	20.62	
		707.5	21.48	20.60	
		701.5	21.50	20.68	
	12RB Low (0)	713.5	21.44	20.51	
		707.5	21.42	20.51	
		701.5	21.51	20.69	
	25RB (0)	713.5	21.47	20.46	
		707.5	21.46	20.53	
		701.5	21.43	20.58	
	10 MHz	1RB High (49)	711	22.60	21.43
			707.5	22.65	21.95
			704	22.58	21.59
		1RB Middle (24)	711	22.71	21.60
			707.5	22.73	22.01
			704	22.67	21.65
1RB Low (0)		711	22.51	21.43	
		707.5	22.57	21.82	
		704	22.45	21.48	
25RB High (25)		711	21.58	20.59	
		707.5	21.80	20.89	
		704	21.75	20.88	
25RB Middle (12)		711	21.64	20.70	
		707.5	21.63	20.67	
		704	21.61	20.74	
25RB Low (0)		711	21.38	20.45	
		707.5	21.51	20.58	
		704	21.71	20.88	
50RB (0)		711	21.45	20.49	
		707.5	21.72	20.80	
		704	21.74	20.83	

Band 13				
Bandwidth (MHz)	RB allocation	Frequency (MHz)	QPSK	16QAM
	RB offset (Start RB)		Actual output power (dBm)	Actual output power (dBm)
5 MHz	1RB High (24)	784.5	22.61	21.74
		782	22.63	21.78
		779.5	22.61	22.14
	1RB Middle (12)	784.5	22.85	21.99
		782	22.93	22.08
		779.5	22.72	22.22
	1RB Low (0)	784.5	22.60	21.75
		782	22.44	21.55
		779.5	22.48	21.90
	12RB High (13)	784.5	21.70	20.74
		782	21.74	20.81
		779.5	21.67	20.82
	12RB Middle (6)	784.5	21.75	20.84
		782	21.77	20.87
		779.5	21.60	20.77
	12RB Low (0)	784.5	21.72	20.84
		782	21.62	20.74
		779.5	21.41	20.52
25RB (0)	784.5	21.75	20.75	
	782	21.72	20.77	
	779.5	21.54	20.68	
10 MHz	1RB High (49)	782	22.60	21.65
	1RB Middle (24)	782	22.63	21.67
	1RB Low (0)	782	22.43	21.40
	25RB High (25)	782	21.64	20.76
	25RB Middle (12)	782	21.62	20.79
	25RB Low (0)	782	21.42	20.52
	50RB (0)	782	21.52	20.56

Band 66					
Bandwidth (MHz)	RB allocation	Frequency (MHz)	QPSK	16QAM	
	RB offset (Start RB)		Actual output power (dBm)	Actual output power (dBm)	
1.4 MHz	1RB High (5)	1779.3	22.48	21.53	
		1745	22.58	21.69	
		1710.7	22.59	21.94	
	1RB Middle (3)	1779.3	22.65	21.60	
		1745	22.68	21.88	
		1710.7	22.71	22.11	
	1RB Low (0)	1779.3	22.39	21.48	
		1745	22.51	21.68	
		1710.7	22.52	21.94	
	3RB High (3)	1779.3	22.51	21.67	
		1745	22.64	21.70	
		1710.7	22.67	21.85	
	3RB Middle (1)	1779.3	22.60	21.78	
		1745	22.69	21.77	
		1710.7	22.70	21.86	
	3RB Low (0)	1779.3	22.49	21.70	
		1745	22.65	21.71	
		1710.7	22.64	21.87	
	6RB (0)	1779.3	21.56	20.70	
		1745	21.58	20.75	
		1710.7	21.60	20.51	
	3 MHz	1RB High (14)	1778.5	22.48	21.49
			1745	22.63	21.51
			1711.5	22.57	21.93
		1RB Middle (7)	1778.5	22.68	21.65
			1745	22.77	21.69
			1711.5	22.78	22.12
1RB Low (0)		1778.5	22.51	21.54	
		1745	22.52	21.54	
		1711.5	22.56	21.94	
8RB High (7)		1778.5	21.47	20.55	
		1745	21.56	20.70	
		1711.5	21.55	20.66	
8RB Middle (4)		1778.5	21.54	20.63	
		1745	21.59	20.79	
		1711.5	21.61	20.72	
8RB Low (0)		1778.5	21.52	20.58	
		1745	21.58	20.74	
		1711.5	21.59	20.72	
15RB (0)		1778.5	21.51	20.52	
		1745	21.55	20.66	
		1711.5	21.53	20.60	
5 MHz		1RB High (24)	1777.5	22.48	21.55
			1745	22.54	22.06

	1RB Middle (12)	1712.5	22.53	21.60	
		1777.5	22.72	21.80	
		1745	22.76	21.97	
	1RB Low (0)	1712.5	22.77	21.83	
		1777.5	22.52	21.55	
		1745	22.54	22.04	
	12RB High (13)	1712.5	22.58	21.60	
		1777.5	21.51	20.55	
		1745	21.62	20.75	
	12RB Middle (6)	1712.5	21.63	20.63	
		1777.5	21.55	20.64	
		1745	21.64	20.76	
	12RB Low (0)	1712.5	21.64	20.65	
		1777.5	21.54	20.58	
		1745	21.60	20.75	
	25RB (0)	1712.5	21.53	20.56	
		1777.5	21.51	20.56	
		1745	21.62	20.69	
	10 MHz	1RB High (49)	1712.5	21.56	20.54
			1775	22.41	21.37
			1745	22.59	21.97
1RB Middle (24)		1715	22.54	21.53	
		1775	22.56	21.47	
		1745	22.72	22.05	
1RB Low (0)		1715	22.64	21.62	
		1775	22.46	21.34	
		1745	22.62	21.95	
25RB High (25)		1715	22.54	21.62	
		1775	21.53	20.56	
		1745	21.68	20.73	
25RB Middle (12)		1715	21.62	20.73	
		1775	21.52	20.55	
		1745	21.65	20.71	
25RB Low (0)		1715	21.62	20.70	
		1775	21.57	20.60	
		1745	21.66	20.70	
50RB (0)		1715	21.57	20.69	
		1775	21.54	20.57	
		1745	21.67	20.70	
15 MHz	1RB High (74)	1715	21.66	20.72	
		1772.5	22.44	21.74	
		1745	22.50	21.91	
	1RB Middle (37)	1717.5	22.43	21.33	
		1772.5	22.55	21.86	
		1745	22.64	22.06	
1RB Low (0)	1717.5	22.57	21.48		
	1772.5	22.51	21.82		
		1745	22.54	21.94	



	36RB High (38)	1717.5	22.48	21.42	
		1772.5	21.56	20.56	
		1745	21.68	20.61	
		1717.5	21.59	20.52	
	36RB Middle (19)	1772.5	21.56	20.56	
		1745	21.64	20.61	
		1717.5	21.63	20.58	
	36RB Low (0)	1772.5	21.59	20.56	
		1745	21.65	20.57	
		1717.5	21.56	20.52	
	75RB (0)	1772.5	21.54	20.56	
		1745	21.65	20.65	
		1717.5	21.58	20.57	
	20 MHz	1RB High (99)	1770	22.09	21.58
			1745	22.16	21.64
1720			22.21	21.71	
1RB Middle (50)		1770	22.49	21.95	
		1745	22.55	22.04	
		1720	22.62	22.10	
1RB Low (0)		1770	22.11	21.63	
		1745	22.19	21.58	
		1720	22.20	21.71	
50RB High (50)		1770	21.28	20.33	
		1745	21.53	20.55	
		1720	21.31	20.40	
50RB Middle (25)		1770	21.37	20.43	
		1745	21.53	20.53	
		1720	21.42	20.46	
50RB Low (0)		1770	21.35	20.38	
		1745	21.55	20.56	
		1720	21.32	20.36	
100RB (0)		1770	21.28	20.34	
		1745	21.53	20.58	
		1720	21.32	20.38	

## Low power

Table 11.3-2: The conducted Power for LTE

Band 2					
Bandwidth (MHz)	RB allocation RB offset (Start RB)	Frequency (MHz)	QPSK	16QAM	
			Actual output power (dBm)	Actual output power (dBm)	
1.4 MHz	1RB High (5)	1909.3	18.90	19.03	
		1880	18.81	18.97	
		1850.7	18.96	19.37	
	1RB Middle (3)	1909.3	19.04	19.17	
		1880	18.97	19.14	
		1850.7	19.09	19.51	
	1RB Low (0)	1909.3	18.88	18.99	
		1880	18.83	18.96	
		1850.7	18.98	19.37	
	3RB High (3)	1909.3	19.13	19.22	
		1880	18.94	18.98	
		1850.7	19.05	19.24	
	3RB Middle (1)	1909.3	19.16	19.29	
		1880	18.98	19.01	
		1850.7	19.10	19.32	
	3RB Low (0)	1909.3	19.07	19.16	
		1880	18.91	18.98	
		1850.7	19.08	19.27	
	6RB (0)	1909.3	19.02	19.17	
		1880	18.92	19.05	
		1850.7	18.99	18.92	
	3 MHz	1RB High (14)	1908.5	18.94	19.03
			1880	18.89	18.83
			1851.5	19.03	19.40
		1RB Middle (7)	1908.5	19.13	19.20
			1880	19.00	19.00
			1851.5	19.09	19.56
1RB Low (0)		1908.5	19.01	19.14	
		1880	18.84	18.86	
		1851.5	19.02	19.41	
8RB High (7)		1908.5	18.98	19.08	
		1880	18.87	19.00	
		1851.5	18.97	19.12	
8RB Middle (4)		1908.5	19.08	19.14	
		1880	18.93	19.08	
		1851.5	19.04	19.15	
8RB Low (0)		1908.5	19.11	19.15	
		1880	18.94	19.03	
		1851.5	19.03	19.15	
15RB (0)		1908.5	19.05	19.05	
		1880	18.93	18.94	
		1851.5	19.00	19.07	

5 MHz	1RB High (24)	1907.5	19.01	19.11
		1880	18.83	19.00
		1852.5	18.87	19.41
	1RB Middle (12)	1907.5	19.32	19.37
		1880	19.12	19.23
		1852.5	19.03	19.66
	1RB Low (0)	1907.5	19.04	19.12
		1880	18.87	19.00
		1852.5	18.88	19.43
	12RB High (13)	1907.5	18.93	18.96
		1880	18.81	18.90
		1852.5	18.92	19.09
	12RB Middle (6)	1907.5	19.13	19.21
		1880	18.95	19.01
		1852.5	19.07	19.13
	12RB Low (0)	1907.5	19.12	19.13
		1880	18.89	18.98
		1852.5	18.92	19.10
	25RB (0)	1907.5	19.04	19.01
		1880	18.87	18.92
		1852.5	18.94	19.05
10 MHz	1RB High (49)	1905	18.99	19.04
		1880	18.78	18.83
		1855	18.94	19.29
	1RB Middle (24)	1905	19.15	19.21
		1880	18.96	18.95
		1855	19.18	19.47
	1RB Low (0)	1905	18.98	19.08
		1880	18.82	18.83
		1855	18.96	19.34
	25RB High (25)	1905	18.92	19.04
		1880	18.82	18.88
		1855	18.97	19.09
	25RB Middle (12)	1905	19.11	19.24
		1880	18.94	18.98
		1855	19.02	19.11
	25RB Low (0)	1905	19.08	19.13
		1880	18.93	18.99
		1855	18.95	19.00
	50RB (0)	1905	19.02	19.08
		1880	18.90	18.90
		1855	18.98	19.07
15 MHz	1RB High (74)	1902.5	19.03	19.35
		1880	18.83	19.37
		1857.5	18.74	18.77
	1RB Middle (37)	1902.5	19.14	19.45
		1880	18.94	19.40
		1857.5	18.88	18.91

	1RB Low (0)	1902.5	19.03	19.41
		1880	18.81	19.25
		1857.5	18.81	18.84
	36RB High (38)	1902.5	19.06	19.08
		1880	18.89	18.83
		1857.5	18.97	18.98
	36RB Middle (19)	1902.5	19.18	19.19
		1880	18.95	18.90
		1857.5	19.00	19.00
	36RB Low (0)	1902.5	19.05	19.09
		1880	18.96	18.92
		1857.5	18.95	18.97
	75RB (0)	1902.5	19.07	19.10
		1880	18.92	18.91
		1857.5	19.00	19.01
20 MHz	1RB High (99)	1900	18.69	19.17
		1880	18.55	19.03
		1860	18.60	19.13
	1RB Middle (50)	1900	19.10	19.59
		1880	18.93	19.29
		1860	18.95	19.52
	1RB Low (0)	1900	18.64	19.18
		1880	18.47	18.95
		1860	18.66	19.20
	50RB High (50)	1900	18.90	18.92
		1880	18.71	18.76
		1860	18.92	19.00
	50RB Middle (25)	1900	18.98	19.05
		1880	18.88	18.87
		1860	18.90	18.97
	50RB Low (0)	1900	18.92	19.01
		1880	18.88	18.91
		1860	18.84	18.93
	100RB (0)	1900	18.89	18.93
		1880	18.83	18.89
		1860	18.89	18.94

Band 66					
Bandwidth (MHz)	RB allocation	Frequency (MHz)	QPSK	16QAM	
	RB offset (Start RB)		Actual output power (dBm)	Actual output power (dBm)	
1.4 MHz	1RB High (5)	1779.3	19.51	19.66	
		1745	19.62	20.02	
		1710.7	19.56	19.70	
	1RB Middle (3)	1779.3	19.67	19.86	
		1745	19.78	20.20	
		1710.7	19.75	19.82	
	1RB Low (0)	1779.3	19.52	19.67	
		1745	19.59	20.05	
		1710.7	19.54	19.70	
	3RB High (3)	1779.3	19.62	19.68	
		1745	19.72	19.96	
		1710.7	19.79	19.95	
	3RB Middle (1)	1779.3	19.65	19.73	
		1745	19.76	19.96	
		1710.7	19.79	19.98	
	3RB Low (0)	1779.3	19.60	19.66	
		1745	19.72	19.99	
		1710.7	19.71	19.90	
	6RB (0)	1779.3	19.58	19.70	
		1745	19.65	19.57	
		1710.7	19.68	19.86	
	3 MHz	1RB High (14)	1778.5	19.55	19.47
			1745	19.65	20.06
			1711.5	19.57	19.65
		1RB Middle (7)	1778.5	19.64	19.64
			1745	19.82	20.19
			1711.5	19.72	19.85
1RB Low (0)		1778.5	19.48	19.51	
		1745	19.67	20.03	
		1711.5	19.60	19.73	
8RB High (7)		1778.5	19.52	19.68	
		1745	19.60	19.76	
		1711.5	19.61	19.69	
8RB Middle (4)		1778.5	19.60	19.73	
		1745	19.63	19.79	
		1711.5	19.64	19.74	
8RB Low (0)		1778.5	19.60	19.71	
		1745	19.62	19.75	
		1711.5	19.64	19.67	
15RB (0)		1778.5	19.56	19.62	
		1745	19.63	19.69	
		1711.5	19.61	19.63	
5 MHz		1RB High (24)	1777.5	19.48	19.63
			1745	19.54	20.10

	1RB Middle (12)	1712.5	19.56	19.71	
		1777.5	19.73	19.87	
		1745	19.79	20.17	
		1712.5	19.81	19.91	
		1RB Low (0)	1777.5	19.54	19.66
			1745	19.57	20.11
			1712.5	19.61	19.69
		12RB High (13)	1777.5	19.44	19.55
			1745	19.55	19.83
	1712.5		19.61	19.68	
	12RB Middle (6)	1777.5	19.60	19.66	
		1745	19.65	19.87	
		1712.5	19.70	19.73	
	12RB Low (0)	1777.5	19.50	19.57	
		1745	19.60	19.82	
		1712.5	19.55	19.61	
	25RB (0)	1777.5	19.49	19.53	
		1745	19.60	19.76	
		1712.5	19.59	19.58	
	10 MHz	1RB High (49)	1775	19.45	19.56
			1745	19.60	20.04
			1715	19.58	19.68
		1RB Middle (24)	1775	19.59	19.57
			1745	19.75	20.09
			1715	19.67	19.75
		1RB Low (0)	1775	19.47	19.44
			1745	19.64	20.05
1715			19.58	19.69	
25RB High (25)		1775	19.50	19.51	
		1745	19.63	19.80	
		1715	19.70	19.84	
25RB Middle (12)		1775	19.55	19.61	
		1745	19.68	19.79	
		1715	19.68	19.77	
25RB Low (0)		1775	19.58	19.60	
		1745	19.62	19.77	
		1715	19.55	19.68	
50RB (0)		1775	19.51	19.54	
		1745	19.65	19.80	
		1715	19.65	19.71	
15 MHz		1RB High (74)	1772.5	19.37	19.11
			1745	19.56	19.91
			1717.5	19.49	19.99
		1RB Middle (37)	1772.5	19.47	19.49
			1745	19.68	20.07
			1717.5	19.65	20.09
	1RB Low (0)	1772.5	19.43	19.42	
		1745	19.58	20.01	

	36RB High (38)	1717.5	19.57	20.06	
		1772.5	19.50	19.50	
		1745	19.65	19.76	
	36RB Middle (19)	1717.5	19.54	19.56	
		1772.5	19.59	19.58	
		1745	19.65	19.74	
	36RB Low (0)	1717.5	19.67	19.63	
		1772.5	19.55	19.55	
		1745	19.62	19.75	
	75RB (0)	1717.5	19.59	19.55	
		1772.5	19.50	19.57	
		1745	19.64	19.73	
	20 MHz	1RB High (99)	1717.5	19.60	19.58
			1770	19.14	19.71
			1745	19.19	19.71
1RB Middle (50)		1720	19.25	19.82	
		1770	19.52	20.06	
		1745	19.60	19.97	
1RB Low (0)		1720	19.58	20.17	
		1770	19.13	19.74	
		1745	19.18	19.69	
50RB High (50)		1720	19.27	19.82	
		1770	19.29	19.37	
		1745	19.54	19.60	
50RB Middle (25)		1720	19.39	19.47	
		1770	19.42	19.49	
		1745	19.57	19.56	
50RB Low (0)		1720	19.46	19.55	
		1770	19.40	19.44	
		1745	19.59	19.60	
100RB (0)		1720	19.38	19.44	
		1770	19.33	19.42	
		1745	19.59	19.63	
			1720	19.33	19.41

## 11.4 Wi-Fi and BT Measurement result

The maximum output power of BT antenna is 9.97dBm.

The maximum tune up of BT antenna is 10.5dBm.

The average conducted power for Wi-Fi is as following:

802.11b(dBm)									
Channel\data rate	1Mbps	2Mbps	5.5Mbps	11Mbps					
11(2462MHz)	16.23	/	16.32	/					
6(2437MHz)	15.90	/	16.02	/					
1(2412MHz)	16.31	16.22	16.36	16.08					
Tune up	16.80	16.80	16.80	16.80					
802.11g(dBm)									
Channel\data rate	6Mbps	9Mbps	12Mbps	18Mbps	24Mbps	36Mbps	48Mbps	54Mbps	
11(2462MHz)	13.80	/	/	/	/	/	/	13.92	
6(2437MHz)	13.55	/	/	/	/	/	/	13.71	
1(2412MHz)	13.85	13.84	13.82	13.83	13.81	13.62	13.99	14.01	
Tune up	14.50	14.50	14.50	14.50	14.50	14.50	14.50	14.50	14.50
802.11n(dBm)-20MHz									
Channel\data rate	MCS0	MCS1	MCS2	MCS3	MCS4	MCS5	MCS6	MCS7	
11(2462MHz)	12.60	/	/	/	/	/	/	12.97	
6(2437MHz)	12.62	/	/	/	/	/	/	12.76	
1(2412MHz)	12.63	12.59	12.58	12.61	12.62	12.94	12.97	12.98	
Tune up	13.50	13.50	13.50	13.50	13.50	13.50	13.50	13.50	13.50
802.11n(dBm)-40MHz									
Channel\data rate	MCS0	MCS1	MCS2	MCS3	MCS4	MCS5	MCS6	MCS7	
9(2452MHz)	9.55	9.31	9.30	9.52	9.26	9.71	9.69	9.70	
6(2437MHz)	9.18	/	/	/	/	9.20	/	/	
3(2422MHz)	9.48	/	/	/	/	9.44	/	/	
Tune up	10.30	10.30	10.30	10.30	10.30	10.30	10.30	10.30	10.30



## 12 Simultaneous TX SAR Considerations

### 12.1 Introduction

The following procedures adopted from “FCC SAR Considerations for Cell Phones with Multiple Transmitters” are applicable to handsets with built-in unlicensed transmitters such as 802.11 a/b/g and Bluetooth devices which may simultaneously transmit with the licensed transmitter.

For this device, the BT and Wi-Fi can transmit simultaneous with other transmitters.

### 12.2 Transmit Antenna Separation Distances

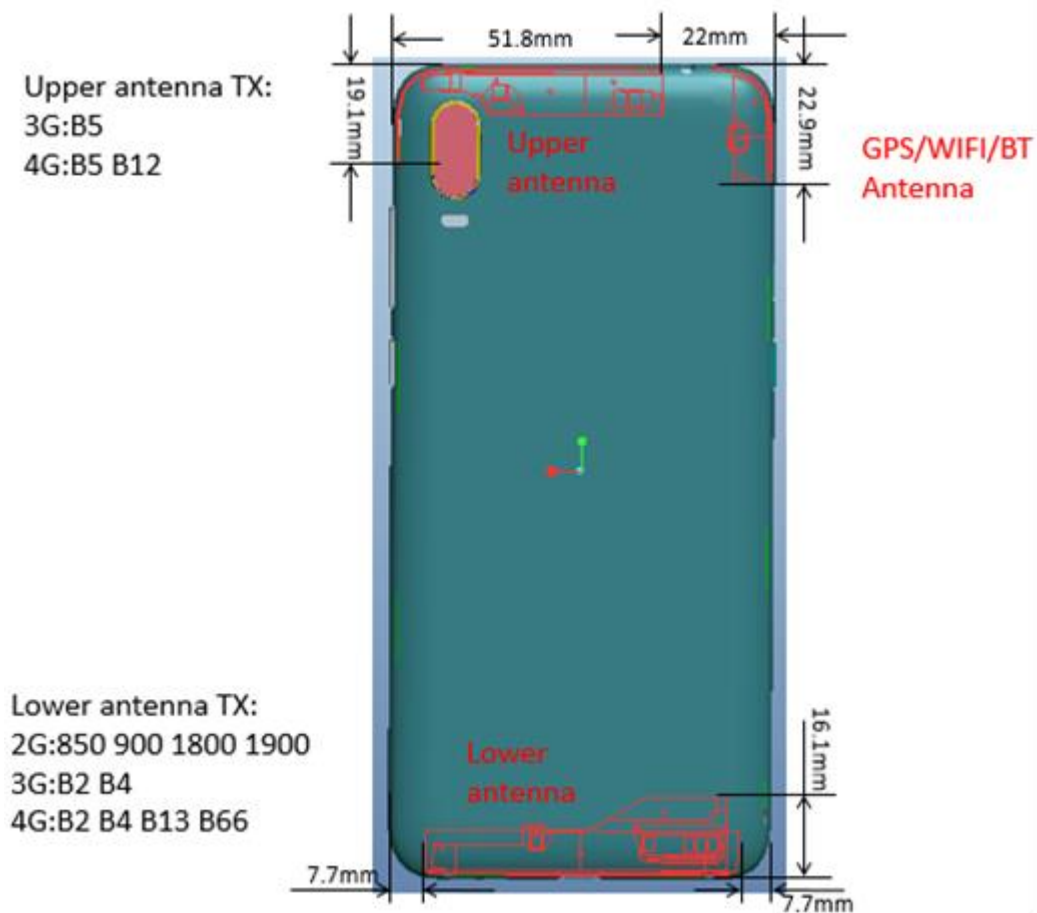

Picture 12.1 Antenna Locations

### 12.3 SAR Measurement Positions

According to the KDB941225 D06 Hot Spot SAR v01, the edges with less than 2.5 cm distance to the antennas need to be tested for SAR.

SAR measurement positions						
Mode	Front	Rear	Left edge	Right edge	Top edge	Bottom edge
Upper antenna	Yes	Yes	Yes	Yes	Yes	No
Lower antenna	Yes	Yes	Yes	Yes	No	Yes
WIFI antenna	Yes	Yes	No	Yes	Yes	No

### 12.4 Standalone SAR Test Exclusion Considerations

Standalone 1-g head or body SAR evaluation by measurement or numerical simulation is not required when the corresponding SAR Exclusion Threshold condition, listed below, is satisfied. The 1-g SAR test exclusion threshold for 100 MHz to 6 GHz at test separation distances  $\leq 50$  mm are determined by:

$[(\text{max. power of channel, including tune-up tolerance, mW}) / (\text{min. test separation distance, mm})] \cdot [\sqrt{f(\text{GHz})}] \leq 3.0$  for 1-g SAR, where

- $f(\text{GHz})$  is the RF channel transmit frequency in GHz
- Power and distance are rounded to the nearest mW and mm before calculation
- The result is rounded to one decimal place for comparison

**Table 12.1: Standalone SAR test exclusion considerations**

Band/Mode	F(GHz)	Position	SAR test exclusion threshold(mW)	RF output power		SAR test exclusion
				dBm	mW	
Bluetooth	2.441	Head	9.60	10.5	11.2	No
		Body	19.20	10.5	11.2	Yes
2.4GHz WLAN	2.45	Head	9.58	16.8	48	No
		Body	19.17	16.8	48	No

### 13 Evaluation of Simultaneous

**Table 13.1: The sum of reported SAR values for cellular antenna and WiFi**

	Position	Band	Cellular antenna	WiFi	Sum
<b>Highest reported SAR value for Head</b>	Right hand, Touch cheek	LTE B5	1.15	0.32	<b>1.47</b>
<b>Highest reported SAR value for Body</b>	Bottom 10mm	LTE B66	1.28	/	<b>1.28</b>

Note1: we have evaluated and chose the highest value of WiFi 2.4G and 5G in the above table.

Note2: we have evaluated and chose the highest value of body 10mm and 15mm in the above table.

**Table 13.2: The sum of reported SAR values for cellular antenna and BT**

	Position	Band	Cellular antenna	BT	Sum
<b>Maximum reported SAR value for Head</b>	Right hand, Touch cheek	LTE B5	1.15	<0.01 <sup>[1]</sup>	<b>1.15</b>
<b>Maximum reported SAR value for Body</b>	Rear 10mm	LTE B2	1.09	0.23 <sup>[2]</sup>	<b>1.32</b>

[1] – The head SAR of BT is too low to get it, so the “<0.01” is used to indicate the head SAR of BT.

[2] - Estimated SAR for Bluetooth (see the table 13.3)

**Table 13.3: Estimated SAR for Bluetooth**

Mode/Band	F (GHz)	Position	Distance (mm)	Upper limit of power *		Estimated <sub>1g</sub> (W/kg)
				dBm	mW	
Bluetooth	2.441	Body	10	10.5	11.2	0.23
Bluetooth	2.441	Body	15	10.5	11.2	0.16

\* - Maximum possible output power declared by manufacturer

When standalone SAR test exclusion applies to an antenna that transmits simultaneously with other antennas, the standalone SAR must be estimated according to following to determine simultaneous transmission SAR test exclusion:

(max. power of channel, including tune-up tolerance, mW)/(min. test separation distance,mm) $\cdot[\sqrt{f(\text{GHz})/x}]$  W/kg for test separation distances  $\leq 50$  mm;

where  $x = 7.5$  for 1-g SAR.

When the minimum test separation distance is  $< 5$  mm, a distance of 5 mm is applied to determine SAR test exclusion

#### Conclusion:

According to the above tables, the sum of reported SAR values is  $< 1.6$ W/kg. So the simultaneous transmission SAR with volume scans is not required.

## 14 SAR Test Result

It is determined by user manual for the distance between the EUT and the phantom bottom. The distance is 10 mm or 15mm and just applied to the condition of body worn accessory.

It is performed for all SAR measurements with area scan based 1-g SAR estimation (Fast SAR). A zoom scan measurement is added when the estimated 1-gSAR is the highest measured SAR in each exposure configuration, wireless mode and frequency band combination or more than 1.2W/kg.

The calculated SAR is obtained by the following formula:

$$\text{Reported SAR} = \text{Measured SAR} \times 10^{(P_{\text{Target}} - P_{\text{Measured}})/10}$$

Where  $P_{\text{Target}}$  is the power of manufacturing upper limit;

$P_{\text{Measured}}$  is the measured power in chapter 11.

**Table 14.1: Duty Cycle**

Mode	Duty Cycle
GSM850	1:4
GSM1900-Normal Power	1:4
GSM1900-Low Power	1:2.67
WCDMA&LTE FDD	1:1

### 14.1 SAR results for Fast SAR

**Table 14.1-1: SAR Values (GSM 850 MHz Band - Head)**

Frequency		Side	Test Position	Figure No./Note	Ambient Temperature: 22.9 °C		Liquid Temperature: 22.5 °C				
Ch.	MHz				Conducted Power (dBm)	Max. tune-up Power (dBm)	Measured SAR(10g) (W/kg)	Reported SAR(10g) (W/kg)	Measured SAR(1g) (W/kg)	Reported SAR(1g) (W/kg)	Power Drift (dB)
190	836.6	Left	Touch	/	32.11	33.30	0.176	<b>0.23</b>	0.215	<b>0.28</b>	0.03
190	836.6	Left	Tilt	/	32.11	33.30	0.111	<b>0.15</b>	0.134	<b>0.18</b>	-0.04
251	848.8	Right	Touch	/	32.10	33.30	0.156	<b>0.21</b>	0.199	<b>0.26</b>	0.07
190	836.6	Right	Touch	/	32.11	33.30	0.190	<b>0.25</b>	0.249	<b>0.33</b>	0.07
128	824.2	Right	Touch	Fig.1	32.09	33.30	0.196	<b>0.26</b>	0.252	<b>0.33</b>	0.11
190	836.6	Right	Tilt	/	32.11	33.30	0.094	<b>0.12</b>	0.116	<b>0.15</b>	-0.07

**Table 14.1-2: SAR Values (GSM 850 MHz Band - Body)**

Frequency		Mode (number of timeslots)	Test Position	Figure No./Note	Ambient Temperature: 22.9 °C		Liquid Temperature: 22.5 °C				
Ch.	MHz				Conducted Power (dBm)	Max. tune-up Power (dBm)	Measured SAR(10g) (W/kg)	Reported SAR(10g) (W/kg)	Measured SAR(1g) (W/kg)	Reported SAR(1g) (W/kg)	Power Drift (dB)
190	836.6	GPRS (2)	Front	/	29.72	30.50	0.138	<b>0.17</b>	0.181	<b>0.22</b>	0.11
251	848.8	GPRS (2)	Rear	/	29.77	30.50	0.187	<b>0.22</b>	0.338	<b>0.40</b>	-0.02
190	836.6	GPRS (2)	Rear	Fig.2	29.72	30.50	0.219	<b>0.26</b>	0.399	<b>0.48</b>	-0.08
128	824.2	GPRS (2)	Rear	/	29.48	30.50	0.200	<b>0.25</b>	0.354	<b>0.45</b>	0.05
190	836.6	GPRS (2)	Left	/	29.72	30.50	0.075	<b>0.09</b>	0.108	<b>0.13</b>	-0.10
190	836.6	GPRS (2)	Right	/	29.72	30.50	0.131	<b>0.16</b>	0.186	<b>0.22</b>	-0.13
190	836.6	GPRS (2)	Bottom	/	29.72	30.50	0.081	<b>0.10</b>	0.145	<b>0.17</b>	0.08
190	836.6	EGPRS (2)	Rear	/	29.64	30.50	0.201	<b>0.25</b>	0.373	<b>0.45</b>	0.05

Note: The distance between the EUT and the phantom bottom is 10mm.

**Table 14.1-3: SAR Values (GSM 1900 MHz Band - Head)**

Frequency		Side	Test Position	Figure No./Note	Ambient Temperature: 22.9 °C		Liquid Temperature: 22.5 °C				
Ch.	MHz				Conducted Power (dBm)	Max. tune-up Power (dBm)	Measured SAR(10g) (W/kg)	Reported SAR(10g) (W/kg)	Measured SAR(1g) (W/kg)	Reported SAR(1g) (W/kg)	Power Drift (dB)
661	1880	Left	Touch	/	29.02	29.50	0.019	<b>0.02</b>	0.029	<b>0.03</b>	0.03
661	1880	Left	Tilt	/	29.02	29.50	0.018	<b>0.02</b>	0.027	<b>0.03</b>	-0.03
810	1909.8	Right	Touch	/	28.93	29.50	0.018	<b>0.02</b>	0.029	<b>0.03</b>	0.05
661	1880	Right	Touch	Fig.3	29.02	29.50	0.025	<b>0.03</b>	0.039	<b>0.04</b>	0.12
512	1850.2	Right	Touch	/	29.16	29.50	0.019	<b>0.02</b>	0.031	<b>0.03</b>	0.14
661	1880	Right	Tilt	/	29.02	29.50	0.016	<b>0.02</b>	0.026	<b>0.03</b>	-0.12

**Table 14.1-4: SAR Values (GSM 1900 MHz Band - Body)**

Frequency		Mode (number of timeslots)	Test Position	Figure No./ Note	Conducted Power (dBm)	Max. tune-up Power (dBm)	Measured SAR(10g) (W/kg)	Reported SAR(10g) (W/kg)	Measured SAR(1g) (W/kg)	Reported SAR(1g) (W/kg)	Power Drift (dB)
Ch.	MHz										
Ambient Temperature: 22.9 °C      Liquid Temperature: 22.5°C											
661	1880	GPRS (3)	Front	/	22.91	23.80	0.198	<b>0.24</b>	0.372	<b>0.46</b>	-0.05
661	1880	GPRS (3)	Rear	/	22.91	23.80	0.228	<b>0.28</b>	0.411	<b>0.50</b>	-0.12
661	1880	GPRS (3)	Left	/	22.91	23.80	0.037	<b>0.05</b>	0.051	<b>0.06</b>	0.06
661	1880	GPRS (3)	Right	/	22.91	23.80	0.024	<b>0.03</b>	0.039	<b>0.05</b>	0.01
810	1909.8	GPRS (3)	Bottom	/	22.97	23.80	0.296	<b>0.36</b>	0.554	<b>0.67</b>	0.03
661	1880	GPRS (3)	Bottom	/	22.91	23.80	0.369	<b>0.45</b>	0.694	<b>0.85</b>	0.03
512	1850.2	GPRS (3)	Bottom	Fig.4	23.01	23.80	0.418	<b>0.50</b>	0.774	<b>0.93</b>	0.02
512	1850.2	EGPRS (3)	Bottom	/	23.10	23.80	0.411	<b>0.48</b>	0.768	<b>0.90</b>	0.05
512	1850.2	GPRS (2)	Bottom	Note1	27.25	27.80	1.160	<b>1.32</b>	3.020	<b>3.43</b>	0.08

Note: The distance between the EUT and the phantom bottom is 10mm.

Note1: The distance between the EUT and the phantom bottom is 0mm.

**Table 14.1-5: SAR Values (GSM 1900 MHz Band - Body)**

Frequency		Mode (number of timeslots)	Test Position	Figure No./ Note	Conducted Power (dBm)	Max. tune-up Power (dBm)	Measured SAR(10g) (W/kg)	Reported SAR(10g) (W/kg)	Measured SAR(1g) (W/kg)	Reported SAR(1g) (W/kg)	Power Drift (dB)
Ch.	MHz										
Ambient Temperature: 22.9 °C      Liquid Temperature: 22.5°C											
661	1880	GPRS (2)	Front	/	27.11	27.80	0.151	<b>0.18</b>	0.269	<b>0.32</b>	0.05
810	1909.8	GPRS (2)	Rear	/	27.10	27.80	0.157	<b>0.18</b>	0.285	<b>0.33</b>	0.05
661	1880	GPRS (2)	Rear	/	27.11	27.80	0.194	<b>0.23</b>	0.354	<b>0.41</b>	-0.10
512	1850.2	GPRS (2)	Rear	Fig.5	27.25	27.80	0.264	<b>0.30</b>	0.462	<b>0.52</b>	-0.05
512	1850.2	EGPRS (2)	Rear	/	27.25	27.80	0.258	<b>0.29</b>	0.453	<b>0.51</b>	0.05

Note: The distance between the EUT and the phantom bottom is 15mm.

**Table 14.1-6: SAR Values (WCDMA 850 MHz Band - Head)**

Frequency		Side	Test Position	Figure No./Note	Conducted Power (dBm)	Max. tune-up Power (dBm)	Measured SAR(10g) (W/kg)	Reported SAR(10g) (W/kg)	Measured SAR(1g) (W/kg)	Reported SAR(1g) (W/kg)	Power Drift (dB)
Ch.	MHz										
Ambient Temperature: 22.9 °C      Liquid Temperature: 22.5°C											
4182	836.4	Left	Touch	/	23.22	24.00	0.394	<b>0.47</b>	0.567	<b>0.68</b>	0.12
4182	836.4	Left	Tilt	/	23.22	24.00	0.241	<b>0.29</b>	0.406	<b>0.49</b>	-0.09
4233	846.6	Right	Touch	/	23.18	24.00	0.382	<b>0.46</b>	0.558	<b>0.67</b>	-0.12
4182	836.4	Right	Touch	Fig.6	23.22	24.00	0.442	<b>0.53</b>	0.631	<b>0.76</b>	0.05
4132	826.4	Right	Touch	/	23.20	24.00	0.352	<b>0.42</b>	0.504	<b>0.61</b>	-0.12
4182	836.4	Right	Tilt	/	23.22	24.00	0.234	<b>0.28</b>	0.395	<b>0.47</b>	-0.10

**Table 14.1-7: SAR Values (WCDMA 850 MHz Band - Body)**

Ambient Temperature: 22.9 °C						Liquid Temperature: 22.5°C				
Frequency		Test Position	Figure No./ Note	Conducted Power (dBm)	Max. tune-up Power (dBm)	Measured SAR(10g) (W/kg)	Reported SAR(10g) (W/kg)	Measured SAR(1g) (W/kg)	Reported SAR(1g) (W/kg)	Power Drift (dB)
Ch.	MHz									
4182	836.4	Front	/	23.22	24.00	0.091	<b>0.11</b>	0.115	<b>0.14</b>	-0.02
4233	846.6	Rear	/	23.18	24.00	0.127	<b>0.15</b>	0.159	<b>0.19</b>	0.06
4182	836.4	Rear	Fig.7	23.22	24.00	0.128	<b>0.15</b>	0.160	<b>0.19</b>	0.13
4132	826.4	Rear	/	23.20	24.00	0.127	<b>0.15</b>	0.157	<b>0.19</b>	-0.09
4182	836.4	Left	/	23.22	24.00	0.057	<b>0.07</b>	0.078	<b>0.09</b>	-0.08
4182	836.4	Right	/	23.22	24.00	0.097	<b>0.12</b>	0.133	<b>0.16</b>	-0.02
4182	836.4	Top	/	23.22	24.00	0.055	<b>0.07</b>	0.090	<b>0.11</b>	-0.09

Note: The distance between the EUT and the phantom bottom is 10mm.

**Table 14.1-8: SAR Values (WCDMA 1700 MHz Band - Head)**

Ambient Temperature: 22.9 °C						Liquid Temperature: 22.5°C					
Frequency		Side	Test Position	Figure No./Note	Conducted Power (dBm)	Max. tune-up Power (dBm)	Measured SAR(10g) (W/kg)	Reported SAR(10g) (W/kg)	Measured SAR(1g) (W/kg)	Reported SAR(1g) (W/kg)	Power Drift (dB)
Ch.	MHz										
1412	1732.4	Left	Touch	/	22.66	23.50	0.140	<b>0.17</b>	0.204	<b>0.25</b>	-0.08
1412	1732.4	Left	Tilt	/	22.66	23.50	0.109	<b>0.13</b>	0.162	<b>0.20</b>	0.03
1513	1752.6	Right	Touch	/	22.78	23.50	0.163	<b>0.19</b>	0.244	<b>0.29</b>	-0.08
1412	1732.4	Right	Touch	/	22.66	23.50	0.172	<b>0.21</b>	0.259	<b>0.31</b>	0.13
1312	1712.4	Right	Touch	Fig.8	22.58	23.50	0.215	<b>0.27</b>	0.321	<b>0.40</b>	0.09
1412	1732.4	Right	Tilt	/	22.66	23.50	0.095	<b>0.12</b>	0.144	<b>0.17</b>	0.01

**Table 14.1-9: SAR Values (WCDMA 1700 MHz Band - Body)**

Ambient Temperature: 22.9 °C						Liquid Temperature: 22.5°C				
Frequency		Test Position	Figure No./ Note	Conducted Power (dBm)	Max. tune-up Power (dBm)	Measured SAR(10g) (W/kg)	Reported SAR(10g) (W/kg)	Measured SAR(1g) (W/kg)	Reported SAR(1g) (W/kg)	Power Drift (dB)
Ch.	MHz									
1412	1732.4	Front	/	19.70	20.50	0.312	<b>0.38</b>	0.556	<b>0.67</b>	0.13
1412	1732.4	Rear	/	19.70	20.50	0.282	<b>0.34</b>	0.483	<b>0.58</b>	0.00
1412	1732.4	Left	/	19.70	20.50	0.056	<b>0.07</b>	0.091	<b>0.11</b>	-0.13
1412	1732.4	Right	/	19.70	20.50	0.058	<b>0.07</b>	0.094	<b>0.11</b>	-0.06
1513	1752.6	Bottom	/	19.75	20.50	0.461	<b>0.55</b>	0.870	<b>1.03</b>	-0.06
1412	1732.4	Bottom	Fig.9	19.70	20.50	0.402	<b>0.48</b>	0.742	<b>0.89</b>	-0.10
1312	1712.4	Bottom	/	19.69	20.50	0.397	<b>0.48</b>	0.739	<b>0.89</b>	0.08
1513	1752.6	Bottom	Note2	22.78	23.50	2.41	<b>2.84</b>	6.33	<b>7.47</b>	0.05
1412	1732.4	Bottom	Note2	22.66	23.50	2.58	<b>3.13</b>	6.42	<b>7.79</b>	0.18
1312	1712.4	Bottom	Note2	22.58	23.50	2.50	<b>3.09</b>	6.39	<b>7.90</b>	0.01

Note1: The distance between the EUT and the phantom bottom is 10mm.

Note2: The distance between the EUT and the phantom bottom is 0mm.

**Table 14.1-10: SAR Values (WCDMA 1700 MHz Band - Body)**

Frequency		Test Position	Figure No./ Note	Conducted Power (dBm)	Max. tune-up Power (dBm)	Ambient Temperature: 22.9 °C		Liquid Temperature: 22.5°C		Power Drift (dB)
Ch.	MHz					Measured SAR(10g) (W/kg)	Reported SAR(10g) (W/kg)	Measured SAR(1g) (W/kg)	Reported SAR(1g) (W/kg)	
1513	1752.6	Front	/	22.78	23.50	0.257	<b>0.30</b>	0.425	<b>0.50</b>	-0.05
1412	1732.4	Front	Fig.10	22.66	23.50	0.268	<b>0.33</b>	0.446	<b>0.54</b>	-0.13
1312	1712.4	Front	/	22.58	23.50	0.258	<b>0.32</b>	0.426	<b>0.53</b>	-0.05
1412	1732.4	Rear	/	22.66	23.50	0.256	<b>0.31</b>	0.412	<b>0.50</b>	0.04

Note1: The distance between the EUT and the phantom bottom is 15mm.

**Table 14.1-11: SAR Values (WCDMA 1900 MHz Band - Head)**

Frequency		Side	Test Position	Figure No./ Note	Conducted Power (dBm)	Max. tune-up Power (dBm)	Ambient Temperature: 22.9 °C		Liquid Temperature: 22.5°C		Power Drift (dB)
Ch.	MHz						Measured SAR(10g) (W/kg)	Reported SAR(10g) (W/kg)	Measured SAR(1g) (W/kg)	Reported SAR(1g) (W/kg)	
9400	1880	Left	Touch	/	22.80	23.50	0.065	<b>0.08</b>	0.099	<b>0.12</b>	0.13
9400	1880	Left	Tilt	/	22.80	23.50	0.059	<b>0.07</b>	0.092	<b>0.11</b>	0.05
9538	1907.6	Right	Touch	/	22.86	23.50	0.062	<b>0.07</b>	0.098	<b>0.11</b>	-0.01
9400	1880	Right	Touch	/	22.80	23.50	0.065	<b>0.08</b>	0.103	<b>0.12</b>	-0.03
9262	1852.4	Right	Touch	Fig.11	22.79	23.50	0.084	<b>0.10</b>	0.131	<b>0.15</b>	-0.07
9400	1880	Right	Tilt	/	22.80	23.50	0.053	<b>0.06</b>	0.086	<b>0.10</b>	-0.03

**Table 14.1-12: SAR Values (WCDMA 1900 MHz Band - Body)**

Frequency		Test Position	Figure No./ Note	Conducted Power (dBm)	Max. tune-up Power (dBm)	Ambient Temperature: 22.9 °C		Liquid Temperature: 22.5°C		Power Drift (dB)
Ch.	MHz					Measured SAR(10g) (W/kg)	Reported SAR(10g) (W/kg)	Measured SAR(1g) (W/kg)	Reported SAR(1g) (W/kg)	
9400	1880	Front	/	19.18	20.00	0.250	<b>0.30</b>	0.462	<b>0.56</b>	-0.05
9400	1880	Rear	/	19.18	20.00	0.293	<b>0.35</b>	0.530	<b>0.64</b>	0.00
9400	1880	Left	/	19.18	20.00	0.027	<b>0.03</b>	0.042	<b>0.05</b>	0.10
9400	1880	Right	/	19.18	20.00	0.031	<b>0.04</b>	0.051	<b>0.06</b>	0.05
9538	1907.6	Bottom	Fig.12	19.27	20.00	0.465	<b>0.55</b>	0.892	<b>1.06</b>	-0.13
9400	1880	Bottom	/	19.18	20.00	0.449	<b>0.54</b>	0.856	<b>1.03</b>	0.10
9262	1852.4	Bottom	/	19.18	20.00	0.458	<b>0.55</b>	0.871	<b>1.05</b>	-0.13
9538	1907.6	Bottom	Note2	22.86	23.50	2.430	<b>2.82</b>	6.430	<b>7.45</b>	0.02
9400	1880	Bottom	Note2	22.80	23.50	2.390	<b>2.81</b>	6.340	<b>7.45</b>	0.18
9262	1852.4	Bottom	Note2	22.79	23.50	2.410	<b>2.84</b>	6.410	<b>7.55</b>	0.06

Note1: The distance between the EUT and the phantom bottom is 10mm.

Note2: The distance between the EUT and the phantom bottom is 0mm.



**Table 14.1-13: SAR Values (WCDMA 1900 MHz Band - Body)**

Frequency		Test Position	Figure No./ Note	Conducted Power (dBm)	Max. tune-up Power (dBm)	Ambient Temperature: 22.9°C		Liquid Temperature: 22.5°C		Power Drift (dB)
Ch.	MHz					Measured SAR(10g) (W/kg)	Reported SAR(10g) (W/kg)	Measured SAR(1g) (W/kg)	Reported SAR(1g) (W/kg)	
9400	1880	Front	/	22.80	23.50	0.273	<b>0.32</b>	0.472	<b>0.55</b>	0.02
9538	1907.6	Rear	/	22.86	23.50	0.301	<b>0.35</b>	0.514	<b>0.60</b>	0.10
9400	1880	Rear	/	22.80	23.50	0.304	<b>0.36</b>	0.518	<b>0.61</b>	-0.10
9262	1852.4	Rear	Fig.13	22.79	23.50	0.325	<b>0.38</b>	0.551	<b>0.65</b>	0.00

Note1: The distance between the EUT and the phantom bottom is 15mm.

**Table 14.1-14: SAR Values (LTE Band2 - Head)**

Frequency		Mode	Side	Test Position	Figure No./ Note	Conducted Power (dBm)	Max. tune-up Power (dBm)	Ambient Temperature: 22.9°C		Liquid Temperature: 22.5°C		Power Drift (dB)
Ch.	MHz							Measured SAR(10g) (W/kg)	Reported SAR(10g) (W/kg)	Measured SAR(1g) (W/kg)	Reported SAR(1g) (W/kg)	
19100	1900	1RB_Mid	Left	Touch	Fig.14	22.61	23.30	0.050	<b>0.06</b>	0.098	<b>0.11</b>	0.12
19100	1900	1RB_Mid	Left	Tilt	/	22.61	23.30	0.031	<b>0.04</b>	0.051	<b>0.06</b>	-0.02
19100	1900	1RB_Mid	Right	Touch	/	22.61	23.30	0.046	<b>0.05</b>	0.075	<b>0.09</b>	-0.03
19100	1900	1RB_Mid	Right	Tilt	/	22.61	23.30	0.032	<b>0.04</b>	0.054	<b>0.06</b>	-0.02
19100	1900	50RB_Mid	Left	Touch	/	21.42	22.30	0.044	<b>0.05</b>	0.071	<b>0.09</b>	-0.07
19100	1900	50RB_Mid	Left	Tilt	/	21.42	22.30	0.025	<b>0.03</b>	0.042	<b>0.05</b>	-0.05
19100	1900	50RB_Mid	Right	Touch	/	21.42	22.30	0.034	<b>0.04</b>	0.057	<b>0.07</b>	0.06
19100	1900	50RB_Mid	Right	Tilt	/	21.42	22.30	0.026	<b>0.03</b>	0.043	<b>0.05</b>	-0.03

Note1: The LTE mode is QPSK\_20MHz.

**Table 14.1-15: SAR Values (LTE Band2 - Body)**

Frequency		Mode	Test Position	Figure No./ Note	Conducted Power (dBm)	Max. tune-up Power (dBm)	Ambient Temperature: 22.9°C		Liquid Temperature: 22.5°C		Power Drift (dB)
Ch.	MHz						Measured SAR(10g) (W/kg)	Reported SAR(10g) (W/kg)	Measured SAR(1g) (W/kg)	Reported SAR(1g) (W/kg)	
19100	1900	1RB_Mid	Front	/	19.10	19.80	0.251	<b>0.29</b>	0.463	<b>0.54</b>	-0.11
19100	1900	1RB_Mid	Rear	/	19.10	19.80	0.478	<b>0.56</b>	0.870	<b>1.02</b>	-0.02
18900	1880	1RB_Mid	Rear	/	18.93	19.80	0.485	<b>0.59</b>	0.862	<b>1.05</b>	0.01
18700	1860	1RB_Mid	Rear	/	18.95	19.80	0.499	<b>0.61</b>	0.900	<b>1.09</b>	-0.08
19100	1900	1RB_Mid	Left	/	19.10	19.80	0.198	<b>0.23</b>	0.377	<b>0.44</b>	0.00
19100	1900	1RB_Mid	Right	/	19.10	19.80	0.079	<b>0.09</b>	0.135	<b>0.16</b>	0.12
19100	1900	1RB_Mid	Bottom	/	19.10	19.80	0.466	<b>0.55</b>	0.889	<b>1.04</b>	0.06
18900	1880	1RB_Mid	Bottom	/	18.93	19.80	0.477	<b>0.58</b>	0.904	<b>1.10</b>	0.06
18700	1860	1RB_Mid	Bottom	/	18.95	19.80	0.496	<b>0.60</b>	0.943	<b>1.15</b>	0.11
19100	1900	50RB_Mid	Front	/	18.98	19.80	0.201	<b>0.24</b>	0.372	<b>0.45</b>	-0.04

19100	1900	50RB_Mid	Rear	/	18.98	19.80	0.389	<b>0.47</b>	0.690	<b>0.83</b>	0.13
18900	1880	50RB_Mid	Rear	/	18.88	19.80	0.395	<b>0.49</b>	0.684	<b>0.85</b>	0.15
18700	1860	50RB_High	Rear	/	18.92	19.80	0.406	<b>0.50</b>	0.714	<b>0.87</b>	0.03
19100	1900	50RB_Mid	Left	/	18.98	19.80	0.162	<b>0.20</b>	0.308	<b>0.37</b>	-0.10
19100	1900	50RB_Mid	Right	/	18.98	19.80	0.062	<b>0.07</b>	0.109	<b>0.13</b>	-0.01
19100	1900	50RB_Mid	Bottom	Fig.15	18.98	19.80	0.533	<b>0.64</b>	1.02	<b>1.23</b>	-0.05
18900	1880	50RB_Mid	Bottom	/	18.88	19.80	0.375	<b>0.46</b>	0.712	<b>0.88</b>	-0.04
18700	1860	50RB_High	Bottom	/	18.92	19.80	0.511	<b>0.63</b>	0.993	<b>1.22</b>	0.13
19100	1900	100RB	Rear	/	18.89	19.80	0.411	<b>0.51</b>	0.731	<b>0.90</b>	0.05
19100	1900	100RB	Bottom	/	18.89	19.80	0.502	<b>0.62</b>	0.983	<b>1.21</b>	0.17
19100	1900	1RB_Mid	Bottom	Note2	22.61	23.30	2.71	<b>3.18</b>	7.12	<b>8.35</b>	0.05
18900	1880	1RB_Mid	Bottom	Note2	22.43	23.30	2.73	<b>3.34</b>	7.13	<b>8.71</b>	-0.02
18700	1860	1RB_Mid	Bottom	Note2	22.46	23.30	2.70	<b>3.28</b>	7.10	<b>8.62</b>	0.06
19100	1900	50RB_Mid	Bottom	Headset	18.98	19.80	0.513	<b>0.62</b>	0.980	<b>1.18</b>	0.05

Note1: The distance between the EUT and the phantom bottom is 10mm.

Note2: The distance between the EUT and the phantom bottom is 0mm.

Note3: The LTE mode is QPSK\_20MHz.

**Table 14.1-16: SAR Values (LTE Band2 - Body)**

Ambient Temperature: 22.9°C						Liquid Temperature: 22.5°C					
Frequency		Mode	Test Position	Figure No./ Note	Conducted Power (dBm)	Max. tune-up Power (dBm)	Measured SAR(10g) (W/kg)	Reported SAR(10g) (W/kg)	Measured SAR(1g) (W/kg)	Reported SAR(1g) (W/kg)	Power Drift (dB)
Ch.	MHz										
19100	1900	1RB_Mid	Front	/	22.61	23.30	0.242	<b>0.28</b>	0.415	<b>0.49</b>	-0.03
19100	1900	1RB_Mid	Rear	/	22.61	23.30	0.406	<b>0.48</b>	0.713	<b>0.84</b>	0.05
18900	1880	1RB_Mid	Rear	/	22.43	23.30	0.418	<b>0.51</b>	0.737	<b>0.90</b>	0.01
18700	1860	1RB_Mid	Rear	Fig.16	22.46	23.30	0.425	<b>0.52</b>	0.745	<b>0.90</b>	-0.07
19100	1900	50RB_Mid	Front	/	21.42	22.30	0.192	<b>0.24</b>	0.330	<b>0.40</b>	0.11
19100	1900	50RB_High	Rear	/	21.42	22.30	0.328	<b>0.40</b>	0.578	<b>0.71</b>	-0.01
19100	1900	100RB	Rear	/	21.35	22.30	0.317	<b>0.39</b>	0.549	<b>0.68</b>	0.05

Note1: The distance between the EUT and the phantom bottom is 15mm.

Note2: The LTE mode is QPSK\_20MHz.

**Table 14.1-17: SAR Values (LTE Band5- Head)**

Ambient Temperature: 22.9°C						Liquid Temperature: 22.5°C						
Frequency		Mode	Side	Test Position	Figure No./ Note	Conducted Power (dBm)	tune-up Power (dBm)	Measured SAR(10g) (W/kg)	Reported SAR(10g) (W/kg)	Measured SAR(1g) (W/kg)	Reported SAR(1g) (W/kg)	Power Drift (dB)
Ch.	MHz											
20525	836.5	1RB_Mid	Left	Touch	/	22.80	23.30	0.479	<b>0.54</b>	0.706	<b>0.79</b>	-0.13
20525	836.5	1RB_Mid	Left	Tilt	/	22.80	23.30	0.287	<b>0.32</b>	0.419	<b>0.47</b>	0.05
20600	844	1RB_Mid	Right	Touch	Fig.17	22.68	23.30	0.653	<b>0.75</b>	0.998	<b>1.15</b>	-0.03
20525	836.5	1RB_Mid	Right	Touch		22.80	23.30	0.598	<b>0.67</b>	0.916	<b>1.03</b>	0.08

20450	829	1RB_Mid	Right	Touch		22.78	23.30	0.537	<b>0.61</b>	0.822	<b>0.93</b>	0.02
20525	836.5	1RB_Mid	Right	Tilt	/	22.80	23.30	0.315	<b>0.35</b>	0.463	<b>0.52</b>	0.04
20525	836.5	25RB_Low	Left	Touch	/	21.80	22.30	0.379	<b>0.43</b>	0.561	<b>0.63</b>	-0.09
20525	836.5	25RB_Low	Left	Tilt	/	21.80	22.30	0.229	<b>0.26</b>	0.336	<b>0.38</b>	-0.09
20525	836.5	25RB_Low	Right	Touch	/	21.80	22.30	0.462	<b>0.52</b>	0.706	<b>0.79</b>	0.10
20525	836.5	25RB_Low	Right	Tilt	/	21.80	22.30	0.253	<b>0.28</b>	0.374	<b>0.42</b>	0.01
20525	836.5	50RB	Right	Touch	/	21.79	22.30	0.437	<b>0.49</b>	0.672	<b>0.76</b>	0.05

Note1: The LTE mode is QPSK\_10MHz.

**Table 14.1-18: SAR Values (LTE Band26 - Body)**

Ambient Temperature: 22.9 °C						Liquid Temperature: 22.5 °C					
Frequency		Mode	Test Position	Figure No./ Note	Conduct ed Power (dBm)	tune-up Power (dBm)	Measured SAR(10g) (W/kg)	Reported SAR(10g) (W/kg)	Measured SAR(1g) (W/kg)	Reported SAR(1g) (W/kg)	Power Drift (dB)
Ch.	MHz										
20525	836.5	1RB_Mid	Front	/	22.80	23.30	0.176	<b>0.20</b>	0.230	<b>0.26</b>	0.02
20525	836.5	1RB_Mid	Rear	Fig.18	22.80	23.30	0.219	<b>0.25</b>	0.331	<b>0.37</b>	-0.07
20525	836.5	1RB_Mid	Left	/	22.80	23.30	0.066	<b>0.07</b>	0.075	<b>0.08</b>	0.05
20525	836.5	1RB_Mid	Right	/	22.80	23.30	0.175	<b>0.20</b>	0.198	<b>0.22</b>	0.12
20525	836.5	1RB_Mid	Top	/	22.80	23.30	0.209	<b>0.23</b>	0.306	<b>0.34</b>	0.07
20525	836.5	25RB_Low	Front	/	21.80	22.30	0.137	<b>0.15</b>	0.173	<b>0.19</b>	-0.03
20525	836.5	25RB_Low	Rear	/	21.80	22.30	0.195	<b>0.22</b>	0.250	<b>0.28</b>	-0.05
20525	836.5	25RB_Low	Left	/	21.80	22.30	0.053	<b>0.06</b>	0.059	<b>0.07</b>	0.07
20525	836.5	25RB_Low	Right	/	21.80	22.30	0.141	<b>0.16</b>	0.159	<b>0.18</b>	-0.08
20525	836.5	25RB_Low	Top	/	21.80	22.30	0.146	<b>0.16</b>	0.218	<b>0.24</b>	-0.05

Note1: The distance between the EUT and the phantom bottom is 10mm.

Note2: The LTE mode is QPSK\_10MHz.

**Table 14.1-19: SAR Values (LTE Band12 - Head)**

Ambient Temperature: 22.9 °C						Liquid Temperature: 22.5 °C						
Frequency		Mode	Side	Test Position	Figure No./ Note	Conduct ed Power (dBm)	Max. tune-up Power (dBm)	Measured SAR(10g) (W/kg)	Reported SAR(10g) (W/kg)	Measured SAR(1g) (W/kg)	Reported SAR(1g) (W/kg)	Power Drift (dB)
Ch.	MHz											
23095	707.5	1RB_Mid	Left	Touch	Fig.19	22.73	23.30	0.346	<b>0.39</b>	0.461	<b>0.53</b>	-0.12
23095	707.5	1RB_Mid	Left	Tilt	/	22.73	23.30	0.264	<b>0.30</b>	0.409	<b>0.47</b>	-0.06
23095	707.5	1RB_Mid	Right	Touch	/	22.73	23.30	0.272	<b>0.31</b>	0.360	<b>0.41</b>	0.04
23095	707.5	1RB_Mid	Right	Tilt	/	22.73	23.30	0.292	<b>0.33</b>	0.421	<b>0.48</b>	-0.10
23095	707.5	25RB_High	Left	Touch	/	21.80	22.30	0.264	<b>0.30</b>	0.347	<b>0.39</b>	0.13
23095	707.5	25RB_High	Left	Tilt	/	21.80	22.30	0.213	<b>0.24</b>	0.318	<b>0.36</b>	0.01
23095	707.5	25RB_High	Right	Touch	/	21.80	22.30	0.190	<b>0.21</b>	0.247	<b>0.28</b>	0.01
23095	707.5	25RB_High	Right	Tilt	/	21.80	22.30	0.235	<b>0.26</b>	0.321	<b>0.36</b>	-0.05

Note1: The LTE mode is QPSK\_10MHz.

**Table 14.1-20: SAR Values (LTE Band12 - Body)**

Ambient Temperature: 22.9 °C						Liquid Temperature: 22.5°C					
Frequency		Mode	Test Position	Figure No./ Note	Conducted Power (dBm)	Max. tune-up Power (dBm)	Measured SAR(10g) (W/kg)	Reported SAR(10g) (W/kg)	Measured SAR(1g) (W/kg)	Reported SAR(1g) (W/kg)	Power Drift (dB)
Ch.	MHz										
23095	707.5	1RB_Mid	Front	/	22.73	23.30	0.143	<b>0.16</b>	0.184	<b>0.21</b>	-0.12
23095	707.5	1RB_Mid	Rear	/	22.73	23.30	0.196	<b>0.22</b>	0.252	<b>0.29</b>	-0.10
23095	707.5	1RB_Mid	Left	/	22.73	23.30	0.128	<b>0.15</b>	0.176	<b>0.20</b>	-0.02
23095	707.5	1RB_Mid	Right	Fig.20	22.73	23.30	0.207	<b>0.24</b>	0.284	<b>0.32</b>	0.00
23095	707.5	1RB_Mid	Top	/	22.73	23.30	0.067	<b>0.08</b>	0.116	<b>0.13</b>	-0.03
23095	707.5	25RB_High	Front	/	21.80	22.30	0.096	<b>0.11</b>	0.124	<b>0.14</b>	-0.04
23095	707.5	25RB_High	Rear	/	21.80	22.30	0.161	<b>0.18</b>	0.207	<b>0.23</b>	0.04
23095	707.5	25RB_High	Left	/	21.80	22.30	0.104	<b>0.12</b>	0.142	<b>0.16</b>	0.05
23095	707.5	25RB_High	Right	/	21.80	22.30	0.165	<b>0.19</b>	0.227	<b>0.25</b>	0.09
23095	707.5	25RB_High	Top	/	21.80	22.30	0.051	<b>0.06</b>	0.089	<b>0.10</b>	0.07

Note1: The distance between the EUT and the phantom bottom is 10mm.

Note2: The LTE mode is QPSK\_10MHz.

**Table 14.1-21: SAR Values (LTE Band13 - Head)**

Ambient Temperature: 22.9 °C						Liquid Temperature: 22.5°C						
Frequency		Mode	Side	Test Position	Figure No./ Note	Conducted Power (dBm)	Max. tune-up Power (dBm)	Measured SAR(10g) (W/kg)	Reported SAR(10g) (W/kg)	Measured SAR(1g) (W/kg)	Reported SAR(1g) (W/kg)	Power Drift (dB)
Ch.	MHz											
23230	782	1RB_Mid	Left	Touch	Fig.21	22.63	23.30	0.180	<b>0.21</b>	0.220	<b>0.26</b>	-0.06
23230	782	1RB_Mid	Left	Tilt	/	22.63	23.30	0.122	<b>0.14</b>	0.143	<b>0.17</b>	-0.07
23230	782	1RB_Mid	Right	Touch	/	22.63	23.30	0.175	<b>0.20</b>	0.218	<b>0.25</b>	-0.02
23230	782	1RB_Mid	Right	Tilt	/	22.63	23.30	0.105	<b>0.12</b>	0.124	<b>0.14</b>	-0.10
23230	782	25RB_High	Left	Touch	/	21.64	22.30	0.123	<b>0.14</b>	0.148	<b>0.17</b>	0.05
23230	782	25RB_High	Left	Tilt	/	21.64	22.30	0.084	<b>0.10</b>	0.100	<b>0.12</b>	0.02
23230	782	25RB_High	Right	Touch	/	21.64	22.30	0.132	<b>0.15</b>	0.164	<b>0.19</b>	0.01
23230	782	25RB_High	Right	Tilt	/	21.64	22.30	0.078	<b>0.09</b>	0.092	<b>0.11</b>	0.02

Note1: The LTE mode is QPSK\_10MHz.

**Table 14.1-22: SAR Values (LTE Band13 - Body)**

Ambient Temperature: 22.9 °C						Liquid Temperature: 22.5°C					
Frequency		Mode	Test Position	Figure No./ Note	Conducted Power (dBm)	Max. tune-up Power (dBm)	Measured SAR(10g) (W/kg)	Reported SAR(10g) (W/kg)	Measured SAR(1g) (W/kg)	Reported SAR(1g) (W/kg)	Power Drift (dB)
Ch.	MHz										
23230	782	1RB_Mid	Front	/	22.63	23.30	0.210	<b>0.25</b>	0.382	<b>0.45</b>	0.07
23230	782	1RB_Mid	Rear		22.63	23.30	0.229	<b>0.27</b>	0.451	<b>0.53</b>	0.03

23230	782	1RB_Mid	Left	/	22.63	23.30	0.154	<b>0.18</b>	0.301	<b>0.35</b>	0.05
23230	782	1RB_Mid	Right	Fig.22	22.63	23.30	0.233	<b>0.27</b>	0.452	<b>0.53</b>	-0.07
23230	782	1RB_Mid	Bottom	/	22.63	23.30	0.075	<b>0.09</b>	0.179	<b>0.21</b>	0.07
23230	782	25RB_High	Front	/	21.64	22.30	0.160	<b>0.19</b>	0.291	<b>0.34</b>	-0.04
23230	782	25RB_High	Rear	/	21.64	22.30	0.201	<b>0.23</b>	0.360	<b>0.42</b>	-0.12
23230	782	25RB_High	Left	/	21.64	22.30	0.122	<b>0.14</b>	0.236	<b>0.27</b>	-0.08
23230	782	25RB_High	Right	/	21.64	22.30	0.177	<b>0.21</b>	0.345	<b>0.40</b>	0.09
23230	782	25RB_High	Bottom	/	21.64	22.30	0.055	<b>0.06</b>	0.127	<b>0.15</b>	0.05

Note1: The distance between the EUT and the phantom bottom is 10mm.

Note2: The LTE mode is QPSK\_10MHz.

**Table 14.1-23: SAR Values (LTE band66 - Head)**

Ambient Temperature: 22.9 °C						Liquid Temperature: 22.5 °C						
Frequency		Mode	Side	Test Position	Figure No.	Conducted Power (dBm)	tune-up Power (dBm)	Measured SAR(10g) (W/kg)	Reported SAR(10g) (W/kg)	Measured SAR(1g) (W/kg)	Reported SAR(1g) (W/kg)	Power Drift (dB)
Ch.	MHz											
132072	1720	1RB_Mid	Left	Touch	/	22.62	23.30	0.113	<b>0.13</b>	0.171	<b>0.20</b>	-0.08
132072	1720	1RB_Mid	Left	Tilt	/	22.62	23.30	0.083	<b>0.10</b>	0.127	<b>0.15</b>	-0.03
132072	1720	1RB_Mid	Right	Touch	Fig.23	22.62	23.30	0.145	<b>0.17</b>	0.227	<b>0.27</b>	0.06
132072	1720	1RB_Mid	Right	Tilt	/	22.62	23.30	0.085	<b>0.10</b>	0.135	<b>0.16</b>	0.00
132333	1745	50RB_Low	Left	Touch	/	21.55	22.30	0.087	<b>0.10</b>	0.131	<b>0.16</b>	-0.02
132333	1745	50RB_Low	Left	Tilt	/	21.55	22.30	0.064	<b>0.08</b>	0.097	<b>0.12</b>	-0.06
132333	1745	50RB_Low	Right	Touch	/	21.55	22.30	0.101	<b>0.12</b>	0.150	<b>0.18</b>	-0.12
132333	1745	50RB_Low	Right	Tilt	/	21.55	22.30	0.054	<b>0.06</b>	0.083	<b>0.10</b>	0.11

**Table 14.1-24: SAR Values (LTE band66 - Body)**

Ambient Temperature: 22.9 °C						Liquid Temperature: 22.5 °C					
Frequency		Mode	Test Position	Figure No./ Note	Conducted Power (dBm)	tune-up Power (dBm)	Measured SAR(10g) (W/kg)	Reported SAR(10g) (W/kg)	Measured SAR(1g) (W/kg)	Reported SAR(1g) (W/kg)	Power Drift (dB)
Ch.	MHz										
132572	1770	1RB_Mid	Front	/	19.52	20.30	0.404	<b>0.48</b>	0.750	<b>0.90</b>	0.04
132322	1745	1RB_Mid	Front	/	19.60	20.30	0.417	<b>0.49</b>	0.773	<b>0.91</b>	-0.01
132072	1720	1RB_Mid	Front	/	19.58	20.30	0.414	<b>0.49</b>	0.778	<b>0.92</b>	-0.11
132572	1770	1RB_Mid	Rear	/	19.52	20.30	0.369	<b>0.44</b>	0.659	<b>0.79</b>	0.03
132322	1745	1RB_Mid	Rear	/	19.60	20.30	0.394	<b>0.46</b>	0.708	<b>0.83</b>	0.05
132072	1720	1RB_Mid	Rear	/	19.58	20.30	0.351	<b>0.41</b>	0.616	<b>0.73</b>	-0.13
132322	1745	1RB_Mid	Left	/	19.60	20.30	0.070	<b>0.08</b>	0.115	<b>0.14</b>	-0.12
132322	1745	1RB_Mid	Right	/	19.60	20.30	0.085	<b>0.10</b>	0.143	<b>0.17</b>	0.09
132572	1770	1RB_Mid	Bottom	/	19.52	20.30	0.550	<b>0.66</b>	1.07	<b>1.28</b>	0.01
132322	1745	1RB_Mid	Bottom	Fig.24	19.60	20.30	0.556	<b>0.65</b>	1.09	<b>1.28</b>	-0.03
132072	1720	1RB_Mid	Bottom	/	19.58	20.30	0.527	<b>0.62</b>	1.04	<b>1.23</b>	-0.03
132572	1770	50RB_Mid	Front	/	19.42	20.30	0.396	<b>0.48</b>	0.730	<b>0.89</b>	0.00
132322	1745	50RB_Low	Front	/	19.59	20.30	0.420	<b>0.49</b>	0.788	<b>0.93</b>	0.08

132072	1720	50RB_Mid	Front	/	19.46	20.30	0.374	<b>0.45</b>	0.688	<b>0.83</b>	0.00
132572	1770	50RB_Mid	Rear	/	19.42	20.30	0.387	<b>0.47</b>	0.691	<b>0.85</b>	0.08
132322	1745	50RB_Low	Rear	/	19.59	20.30	0.363	<b>0.43</b>	0.649	<b>0.76</b>	-0.08
132072	1720	50RB_Mid	Rear	/	19.46	20.30	0.356	<b>0.43</b>	0.682	<b>0.83</b>	0.07
132322	1745	50RB_Low	Left	/	19.59	20.30	0.074	<b>0.09</b>	0.123	<b>0.14</b>	0.05
132322	1745	50RB_Low	Right	/	19.59	20.30	0.079	<b>0.09</b>	0.132	<b>0.16</b>	-0.13
132572	1770	50RB_Mid	Bottom	/	19.42	20.30	0.525	<b>0.64</b>	1.02	<b>1.25</b>	0.08
132322	1745	50RB_Low	Bottom	/	19.59	20.30	0.545	<b>0.64</b>	1.08	<b>1.27</b>	0.09
132072	1720	50RB_Mid	Bottom	/	19.46	20.30	0.479	<b>0.58</b>	0.949	<b>1.15</b>	0.09
132322	1745	100RB	Front	/	19.59	20.30	0.396	<b>0.47</b>	0.731	<b>0.86</b>	0.17
132322	1745	100RB	Rear	/	19.59	20.30	0.367	<b>0.43</b>	0.657	<b>0.77</b>	0.01
132322	1745	100RB	Bottom	/	19.59	20.30	0.521	<b>0.61</b>	0.983	<b>1.16</b>	0.09
132572	1770	1RB_Mid	Bottom	Note2	22.49	23.30	2.87	<b>3.46</b>	7.02	<b>8.46</b>	0.08
132322	1745	1RB_Mid	Bottom	Note2	22.55	23.30	2.71	<b>3.22</b>	6.85	<b>8.13</b>	0.15
132072	1720	1RB_Mid	Bottom	Note2	22.62	23.30	2.81	<b>3.29</b>	6.94	<b>8.11</b>	0.08
132322	1745	1RB_Mid	Bottom	Headset	19.60	20.30	0.522	<b>0.61</b>	0.974	<b>1.14</b>	0.15

Note1: The distance between the EUT and the phantom bottom is 10mm.

Note2: The distance between the EUT and the phantom bottom is 0mm.

Note3: The LTE mode is QPSK\_20MHz.

**Table 14.1-25: SAR Values (LTE band66 - Body)**

Frequency		Mode	Test Position	Figure No./ Note	Ambient Temperature: 22.9 °C		Liquid Temperature: 22.5 °C				
Ch.	MHz				Conducted Power (dBm)	Max. tune-up Power (dBm)	Measured SAR(10g) (W/kg)	Reported SAR(10g) (W/kg)	Measured SAR(1g) (W/kg)	Reported SAR(1g) (W/kg)	Power Drift (dB)
132572	1770	1RB_Mid	Front	/	22.49	23.30	0.382	<b>0.46</b>	0.645	<b>0.78</b>	0.11
132322	1745	1RB_Mid	Front	Fig.25	22.55	23.30	0.452	<b>0.54</b>	0.754	<b>0.90</b>	0.04
132072	1720	1RB_Mid	Front	/	22.62	23.30	0.420	<b>0.49</b>	0.696	<b>0.81</b>	-0.12
132072	1720	1RB_Mid	Rear	/	22.62	23.30	0.389	<b>0.45</b>	0.633	<b>0.74</b>	0.01
132333	1745	50RB_Low	Front	/	21.55	22.30	0.338	<b>0.40</b>	0.566	<b>0.67</b>	-0.13
132333	1745	50RB_Low	Rear	/	21.55	22.30	0.328	<b>0.39</b>	0.538	<b>0.64</b>	0.05
132333	1745	100RB	Front	/	21.53	22.30	0.322	<b>0.38</b>	0.517	<b>0.62</b>	0.17

Note1: The distance between the EUT and the phantom bottom is 15mm.

Note2: The LTE mode is QPSK\_20MHz.

## 14.2 SAR results for Standard procedure

There is zoom scan measurement to be added for the highest measured SAR in each exposure configuration/band.

Test Band	Channel	Frequency	Tune-Up	Measured Power	Test Position	Measured 10g SAR	Measured 1g SAR	Reported 10g SAR	Reported 1g SAR	Power Drift
GSM850	128	824.2	33.30	32.09	Right Cheek	0.205	0.259	0.27	0.34	0.11
GSM850	190	836.6	30.50	29.72	Rear	0.219	0.399	0.26	0.48	-0.08
PCS1900	661	1880	29.50	29.02	Right Cheek	0.025	0.039	0.03	0.04	0.12
PCS1900	512	1850.2	23.80	23.01	Bottom	0.418	0.774	0.50	0.93	0.02
PCS1900	512	1850.2	27.80	27.10	Rear	0.264	0.462	0.30	0.52	-0.05
WCDMA1900-BII	9262	1852.4	23.50	22.79	Right Cheek	0.084	0.131	0.10	0.15	-0.07
WCDMA1900-BII	9538	1907.6	20.00	19.27	Bottom	0.465	0.892	0.55	1.06	-0.13
WCDMA1900-BII	9262	1852.4	23.50	22.79	Rear	0.325	0.551	0.38	0.65	0
WCDMA1700-BIV	1312	1712.4	23.50	22.58	Right Cheek	0.215	0.321	0.27	0.40	0.09
WCDMA1700-BIV	1513	1752.6	20.50	19.75	Bottom	0.461	0.87	0.55	1.03	-0.06
WCDMA1700-BIV	1412	1732.5	23.50	22.66	Front	0.268	0.446	0.33	0.54	-0.13
WCDMA850-BV	4132	826.4	24.00	23.22	Right Cheek	0.442	0.631	0.53	0.76	0.05
WCDMA850-BV	4183	836.6	24.00	23.22	Rear	0.128	0.16	0.15	0.19	0.13
LTE1900-FDD2	19100	1900 MHz	23.30	22.61	Left Cheek	0.050	0.098	0.06	0.11	0.12
LTE1900-FDD2	19100	1900 MHz	19.80	18.98	Bottom	0.533	1.02	0.64	1.23	-0.05
LTE1900-FDD2	18700	1860 MHz	23.30	22.46	Rear	0.425	0.745	0.52	0.90	-0.07
LTE850-FDD5	20600	844 MHz	23.30	22.68	Right Cheek	0.653	0.998	0.75	1.15	-0.03
LTE850-FDD5	20525	836.5 MHz	23.30	22.80	Rear	0.219	0.331	0.25	0.37	-0.07
LTE700-FDD12	23095	707.5 MHz	23.30	22.73	Left Cheek	0.346	0.461	0.39	0.53	-0.12
LTE700-FDD12	23095	707.5 MHz	23.30	22.73	Right	0.207	0.284	0.24	0.32	0
LTE750-FDD13	23230	782 MHz	23.30	22.63	Left Cheek	0.18	0.22	0.21	0.26	-0.06
LTE750-FDD13	23230	782 MHz	23.30	22.63	Right	0.233	0.452	0.27	0.53	-0.07
LTE1700-FDD66	132072	782 MHz	23.30	22.62	Right Cheek	0.145	0.227	0.17	0.27	0.06
LTE1700-FDD66	132322	782 MHz	20.30	19.60	Bottom	0.556	1.09	0.65	1.28	-0.03
LTE1700-FDD66	132322	782 MHz	23.30	22.55	Front	0.452	0.754	0.54	0.90	0.04
WLAN2450	1	2412	16.80	16.36	Right Cheek	0.154	0.29	0.17	0.32	0.03
WLAN2450	1	2412	16.80	16.36	Rear	0.077	0.16	0.09	0.18	0.05

### 14.3 WLAN Evaluation for 2.4G

According to the KDB248227 D01, SAR is measured for 2.4GHz 802.11b DSSS using the initial test position procedure.

#### Head Evaluation

**Table 14.3-1: SAR Values (WLAN - Head)– 802.11b (Fast SAR)**

Frequency		Side	Test Position	Figure No./ Note	Conducted Power (dBm)	Max. tune-up Power (dBm)	Ambient Temperature: 22.9 °C		Liquid Temperature: 22.5 °C		Power Drift (dB)
MHz	Ch.						Measured SAR(10g) (W/kg)	Reported SAR(10g) (W/kg)	Measured SAR(1g) (W/kg)	Reported SAR(1g) (W/kg)	
2412	1	Left	Touch	/	16.36	16.80	0.090	<b>0.10</b>	0.155	<b>0.17</b>	0.05
2412	1	Left	Tilt	/	16.36	16.80	0.091	<b>0.10</b>	0.176	<b>0.19</b>	0.14
2412	1	Right	Touch	/	16.36	16.80	0.138	<b>0.15</b>	0.272	<b>0.30</b>	0.03
2412	1	Right	Tilt	/	16.36	16.80	0.106	<b>0.12</b>	0.201	<b>0.22</b>	0.09

As shown above table, the initial test position for head is “Right Touch”. So the head SAR of WLAN is presented as below:

**Table 14.3-2: SAR Values (WLAN - Head)– 802.11b (Full SAR)**

Frequency		Side	Test Position	Figure No./ Note	Conducted Power (dBm)	Max. tune-up Power (dBm)	Ambient Temperature: 22.9 °C		Liquid Temperature: 22.5 °C		Power Drift (dB)
MHz	Ch.						Measured SAR(10g) (W/kg)	Reported SAR(10g) (W/kg)	Measured SAR(1g) (W/kg)	Reported SAR(1g) (W/kg)	
2412	1	Right	Touch	Fig.26	16.36	16.80	0.154	<b>0.17</b>	0.290	<b>0.32</b>	0.03

Note1: When the reported SAR of the initial test position is > 0.4 W/kg, SAR is repeated for the 802.11 transmission mode configuration tested in the initial test position using subsequent highest estimated 1-g SAR conditions determined by area scans, on the highest maximum output power channel, until the reported SAR is  $\leq$  0.8 W/kg.

Note2: For all positions/configurations tested using the initial test position and subsequent test positions, when the reported SAR is > 0.8 W/kg, SAR is measured for these test positions/configurations on the subsequent next highest measured output power channel until the reported SAR is  $\leq$  1.2 W/kg or all required channels are tested.

According to the KDB248227 D01, The reported SAR must be scaled to 100% transmission duty factor to determine compliance at the maximum tune-up tolerance limit. The scaled reported SAR is presented as below.

**Table 14.3-3: SAR Values (WLAN - Head) – 802.11b (Scaled Reported SAR)**

Frequency		Side	Test Position	Ambient Temperature: 22.9 °C		Liquid Temperature: 22.5 °C	
MHz	Ch.			Actual duty factor	maximum duty factor	Reported SAR (1g)(W/kg)	Scaled reported SAR (1g)(W/kg)
2412	1	Right	Touch	100%	100%	<b>0.32</b>	<b>0.32</b>

SAR is not required for OFDM because the 802.11b adjusted SAR  $\leq$  1.2 W/kg.



**Body Evaluation**
**Table 14.3-4: SAR Values (WLAN - Body)– 802.11b (Fast SAR)**

Frequency		Test Position	Figure No./ Note	Ambient Temperature: 22.9 °C		Liquid Temperature: 22.5 °C		Measured SAR(1g) (W/kg)	Reported SAR(1g)( W/kg)	Power Drift (dB)
MHz	Ch.			Conducted Power (dBm)	Max. tune-up Power (dBm)	Measured SAR(10g) (W/kg)	Reported SAR(10g) (W/kg)			
2412	1	Front	/	16.36	16.80	0.039	<b>0.04</b>	0.064	<b>0.07</b>	0.15
2412	1	Rear	/	16.36	16.80	0.079	<b>0.09</b>	0.152	<b>0.17</b>	0.05
2412	1	Left	/	16.36	16.80	0.047	<b>0.05</b>	0.088	<b>0.10</b>	0.17
2412	1	Top	/	16.36	16.80	0.039	<b>0.04</b>	0.067	<b>0.07</b>	0.09

As shown above table, the initial test position for body is “Rear”. So the body SAR of WLAN is presented as below:

**Table 14.3-5: SAR Values (WLAN - Body)– 802.11b (Full SAR)**

Frequency		Test Position	Figure No./ Note	Ambient Temperature: 22.9 °C		Liquid Temperature: 22.5 °C		Measured SAR(1g) (W/kg)	Reported SAR(1g)( W/kg)	Power Drift (dB)
MHz	Ch.			Conducted Power (dBm)	Max. tune-up Power (dBm)	Measured SAR(10g) (W/kg)	Reported SAR(10g) (W/kg)			
2412	1	Rear	Fig.27	16.36	16.80	0.077	<b>0.09</b>	0.160	<b>0.18</b>	0.05

Note1: When the reported SAR of the initial test position is > 0.4 W/kg, SAR is repeated for the 802.11 transmission mode configuration tested in the initial test position using subsequent highest estimated 1-g SAR conditions determined by area scans, on the highest maximum output power channel, until the reported SAR is  $\leq$  0.8 W/kg.

Note2: For all positions/configurations tested using the initial test position and subsequent test positions, when the reported SAR is > 0.8 W/kg, SAR is measured for these test positions/configurations on the subsequent next highest measured output power channel until the reported SAR is  $\leq$  1.2 W/kg or all required channels are tested.

According to the KDB248227 D01, The reported SAR must be scaled to 100% transmission duty factor to determine compliance at the maximum tune-up tolerance limit. The scaled reported SAR is presented as below.

**Table 14.3-6: SAR Values (WLAN - Body) – 802.11b (Scaled Reported SAR)**

Frequency		Test Position	Ambient Temperature: 22.9 °C		Liquid Temperature: 22.5 °C	
MHz	Ch.		Actual duty factor	maximum duty factor	Reported SAR (1g)(W/kg)	Scaled reported SAR (1g)(W/kg)
2412	1	Rear	100%	100%	<b>0.18</b>	<b>0.18</b>

SAR is not required for OFDM because the 802.11b adjusted SAR  $\leq$  1.2 W/kg.

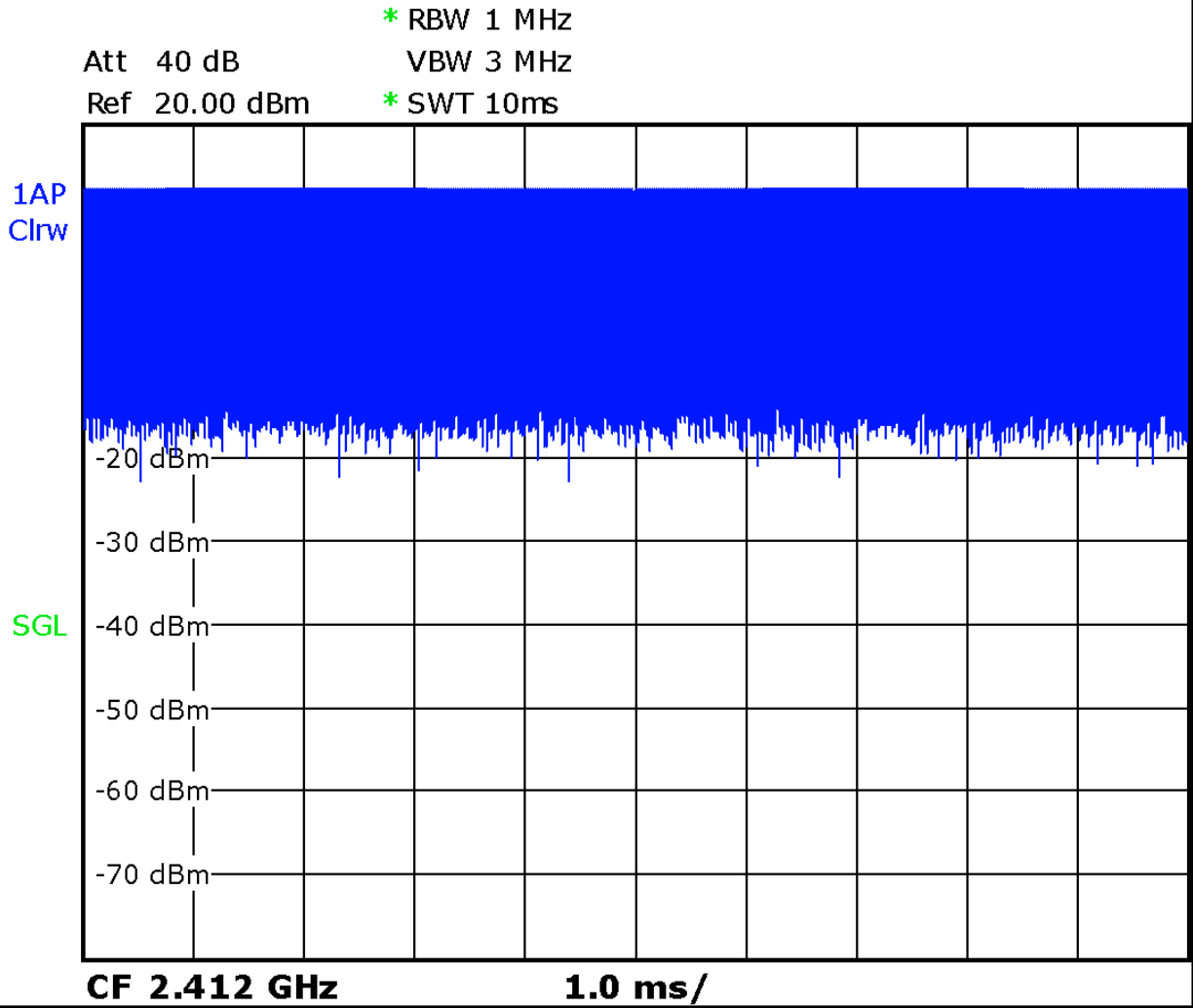

Picture 14.1 Duty factor plot

### 14.4 BT Evaluation

**Table 14.4-1: SAR Values (Bluetooth - Head)**

Ch.	Side	Test Position	Figure No.	Conducted Power (dBm)	Max. tune-up Power (dBm)	Measured SAR(10g) (W/kg)	Reported SAR(10g)(W/kg)	Measured SAR(1g) (W/kg)	Reported SAR(1g) (W/kg)	Power Drift (dB)
39	Left	Touch	/	9.97	10.5	< 0.01	<b>&lt; 0.01</b>	< 0.01	<b>&lt; 0.01</b>	/
39	Left	Tilt	/	9.97	10.5	< 0.01	<b>&lt; 0.01</b>	< 0.01	<b>&lt; 0.01</b>	/
39	Right	Touch	/	9.97	10.5	< 0.01	<b>&lt; 0.01</b>	< 0.01	<b>&lt; 0.01</b>	/
39	Right	Tilt	/	9.97	10.5	< 0.01	<b>&lt; 0.01</b>	< 0.01	<b>&lt; 0.01</b>	/

## 15 SAR Measurement Variability

SAR measurement variability must be assessed for each frequency band, which is determined by the SAR probe calibration point and tissue-equivalent medium used for the device measurements. When both head and body tissue-equivalent media are required for SAR measurements in a frequency band, the variability measurement procedures should be applied to the tissue medium with the highest measured SAR, using the highest measured SAR configuration for that tissue-equivalent medium.

The following procedures are applied to determine if repeated measurements are required.

- 1) Repeated measurement is not required when the original highest measured SAR is  $< 0.80$  W/kg; steps 2) through 4) do not apply.
- 2) When the original highest measured SAR is  $\geq 0.80$  W/kg, repeat that measurement once.
- 3) Perform a second repeated measurement only if the ratio of largest to smallest SAR for the original and first repeated measurements is  $> 1.20$  or when the original or repeated measurement is  $\geq 1.45$  W/kg (~ 10% from the 1-g SAR limit).
- 4) Perform a third repeated measurement only if the original, first or second repeated measurement is  $\geq 1.5$  W/kg and the ratio of largest to smallest SAR for the original, first and second repeated measurements is  $> 1.20$ .

**Table 15.1: SAR Measurement Variability for Body W1700 (1g)**

Frequency		Test Position	Spacing (mm)	Original SAR (W/kg)	First Repeated SAR (W/kg)	The Ratio	Second Repeated SAR (W/kg)
Ch.	MHz						
1513	1752.6	Bottom	10	0.87	0.847	1.03	/

**Table 15.2: SAR Measurement Variability for Body W1900 (1g)**

Frequency		Test Position	Spacing (mm)	Original SAR (W/kg)	First Repeated SAR (W/kg)	The Ratio	Second Repeated SAR (W/kg)
Ch.	MHz						
9538	1907.6	Bottom	10	0.892	0.861	1.04	/

**Table 15.3: SAR Measurement Variability for Body LTE B2 (1g)**

Frequency		Mode	Test Position	Spacing (mm)	Original SAR (W/kg)	First Repeated SAR (W/kg)	The Ratio	Second Repeated SAR (W/kg)
Ch.	MHz							
19100	1900	50RB_Mid	Bottom	10	1.02	0.972	1.05	/

**Table 15.4: SAR Measurement Variability for Head LTE B5 (1g)**

Frequency		Mode	Side	Test Position	Original SAR (W/kg)	First Repeated SAR (W/kg)	The Ratio	Second Repeated SAR (W/kg)
Ch.	MHz							
20600	844	1RB_Mid	Right	Cheek	0.998	0.979	1.02	/

**Table 15.5: SAR Measurement Variability for Body LTE B66 (1g)**

Frequency		Mode	Test Position	Spacing (mm)	Original SAR (W/kg)	First Repeated SAR (W/kg)	The Ratio	Second Repeated SAR (W/kg)
Ch.	MHz							
132322	1745	1RB_Mid	Bottom	10	1.09	1.01	1.08	/

## 16 Measurement Uncertainty

### 16.1 Measurement Uncertainty for Normal SAR Tests (300MHz~3GHz)

No.	Error Description	Type	Uncertainty value	Probably Distribution	Div.	(Ci) 1g	(Ci) 10g	Std. Unc. (1g)	Std. Unc. (10g)	Degree of freedom
<b>Measurement system</b>										
1	Probe calibration	B	6.0	N	1	1	1	6.0	6.0	$\infty$
2	Isotropy	B	4.7	R	$\sqrt{3}$	0.7	0.7	1.9	1.9	$\infty$
3	Boundary effect	B	1.0	R	$\sqrt{3}$	1	1	0.6	0.6	$\infty$
4	Linearity	B	4.7	R	$\sqrt{3}$	1	1	2.7	2.7	$\infty$
5	Detection limit	B	1.0	N	1	1	1	0.6	0.6	$\infty$
6	Readout electronics	B	0.3	R	$\sqrt{3}$	1	1	0.3	0.3	$\infty$
7	Response time	B	0.8	R	$\sqrt{3}$	1	1	0.5	0.5	$\infty$
8	Integration time	B	2.6	R	$\sqrt{3}$	1	1	1.5	1.5	$\infty$
9	RF ambient conditions-noise	B	0	R	$\sqrt{3}$	1	1	0	0	$\infty$
10	RF ambient conditions-reflection	B	0	R	$\sqrt{3}$	1	1	0	0	$\infty$
11	Probe positioned mech. restrictions	B	0.4	R	$\sqrt{3}$	1	1	0.2	0.2	$\infty$
12	Probe positioning with respect to phantom shell	B	2.9	R	$\sqrt{3}$	1	1	1.7	1.7	$\infty$
13	Post-processing	B	1.0	R	$\sqrt{3}$	1	1	0.6	0.6	$\infty$
<b>Test sample related</b>										
14	Test sample positioning	A	3.3	N	1	1	1	3.3	3.3	71
15	Device holder uncertainty	A	3.4	N	1	1	1	3.4	3.4	5
16	Drift of output power	B	5.0	R	$\sqrt{3}$	1	1	2.9	2.9	$\infty$
<b>Phantom and set-up</b>										
17	Phantom uncertainty	B	4.0	R	$\sqrt{3}$	1	1	2.3	2.3	$\infty$
18	Liquid conductivity (target)	B	5.0	R	$\sqrt{3}$	0.64	0.43	1.8	1.2	$\infty$
19	Liquid conductivity (meas.)	A	2.06	N	1	0.64	0.43	1.32	0.89	43
20	Liquid permittivity (target)	B	5.0	R	$\sqrt{3}$	0.6	0.49	1.7	1.4	$\infty$
21	Liquid permittivity (meas.)	A	1.6	N	1	0.6	0.49	1.0	0.8	521

Combined standard uncertainty	$u_c = \sqrt{\sum_{i=1}^{21} c_i^2 u_i^2}$							9.55	9.43	257
Expanded uncertainty (confidence interval of 95 %)	$u_e = 2u_c$							19.1	18.9	

### 16.2 Measurement Uncertainty for Normal SAR Tests (3~6GHz)

No.	Error Description	Type	Uncertainty value	Probably Distribution	Div.	(Ci) 1g	(Ci) 10g	Std. Unc. (1g)	Std. Unc. (10g)	Degree of freedom
<b>Measurement system</b>										
1	Probe calibration	B	6.55	N	1	1	1	6.55	6.55	$\infty$
2	Isotropy	B	4.7	R	$\sqrt{3}$	0.7	0.7	1.9	1.9	$\infty$
3	Boundary effect	B	2.0	R	$\sqrt{3}$	1	1	1.2	1.2	$\infty$
4	Linearity	B	4.7	R	$\sqrt{3}$	1	1	2.7	2.7	$\infty$
5	Detection limit	B	1.0	R	$\sqrt{3}$	1	1	0.6	0.6	$\infty$
6	Readout electronics	B	0.3	R	$\sqrt{3}$	1	1	0.3	0.3	$\infty$
7	Response time	B	0.8	R	$\sqrt{3}$	1	1	0.5	0.5	$\infty$
8	Integration time	B	2.6	R	$\sqrt{3}$	1	1	1.5	1.5	$\infty$
9	RF ambient conditions-noise	B	0	R	$\sqrt{3}$	1	1	0	0	$\infty$
10	RFambient conditions-reflection	B	0	R	$\sqrt{3}$	1	1	0	0	$\infty$
11	Probe positioned mech. restrictions	B	0.8	R	$\sqrt{3}$	1	1	0.5	0.5	$\infty$
12	Probe positioning with respect to phantom shell	B	6.7	R	$\sqrt{3}$	1	1	3.9	3.9	$\infty$
13	Post-processing	B	4.0	R	$\sqrt{3}$	1	1	2.3	2.3	$\infty$
<b>Test sample related</b>										
14	Test sample positioning	A	3.3	N	1	1	1	3.3	3.3	71
15	Device holder uncertainty	A	3.4	N	1	1	1	3.4	3.4	5
16	Drift of output power	B	5.0	R	$\sqrt{3}$	1	1	2.9	2.9	$\infty$
<b>Phantom and set-up</b>										
17	Phantom uncertainty	B	4.0	R	$\sqrt{3}$	1	1	2.3	2.3	$\infty$
18	Liquid conductivity (target)	B	5.0	R	$\sqrt{3}$	0.64	0.43	1.8	1.2	$\infty$
19	Liquid conductivity (meas.)	A	2.06	N	1	0.64	0.43	1.32	0.89	43
20	Liquid permittivity	B	5.0	R	$\sqrt{3}$	0.6	0.49	1.7	1.4	$\infty$

	(target)									
21	Liquid permittivity (meas.)	A	1.6	N	1	0.6	0.49	1.0	0.8	521
Combined standard uncertainty		$u_c = \sqrt{\sum_{i=1}^{21} c_i^2 u_i^2}$						10.7	10.6	257
Expanded uncertainty (confidence interval of 95 %)		$u_e = 2u_c$						21.4	21.1	

### 16.3 Measurement Uncertainty for Fast SAR Tests (300MHz~3GHz)

No.	Error Description	Type	Uncertainty value	Probably Distribution	Div.	(Ci) 1g	(Ci) 10g	Std. Unc. (1g)	Std. Unc. (10g)	Degree of freedom
<b>Measurement system</b>										
1	Probe calibration	B	6.0	N	1	1	1	6.0	6.0	$\infty$
2	Isotropy	B	4.7	R	$\sqrt{3}$	0.7	0.7	1.9	1.9	$\infty$
3	Boundary effect	B	1.0	R	$\sqrt{3}$	1	1	0.6	0.6	$\infty$
4	Linearity	B	4.7	R	$\sqrt{3}$	1	1	2.7	2.7	$\infty$
5	Detection limit	B	1.0	R	$\sqrt{3}$	1	1	0.6	0.6	$\infty$
6	Readout electronics	B	0.3	R	$\sqrt{3}$	1	1	0.3	0.3	$\infty$
7	Response time	B	0.8	R	$\sqrt{3}$	1	1	0.5	0.5	$\infty$
8	Integration time	B	2.6	R	$\sqrt{3}$	1	1	1.5	1.5	$\infty$
9	RF ambient conditions-noise	B	0	R	$\sqrt{3}$	1	1	0	0	$\infty$
10	RFambient conditions-reflection	B	0	R	$\sqrt{3}$	1	1	0	0	$\infty$
11	Probe positioned mech. Restrictions	B	0.4	R	$\sqrt{3}$	1	1	0.2	0.2	$\infty$
12	Probe positioning with respect to phantom shell	B	2.9	R	$\sqrt{3}$	1	1	1.7	1.7	$\infty$
13	Post-processing	B	1.0	R	$\sqrt{3}$	1	1	0.6	0.6	$\infty$
14	Fast SAR z-Approximation	B	7.0	R	$\sqrt{3}$	1	1	4.0	4.0	$\infty$
<b>Test sample related</b>										
15	Test sample positioning	A	3.3	N	1	1	1	3.3	3.3	71
16	Device holder uncertainty	A	3.4	N	1	1	1	3.4	3.4	5
17	Drift of output power	B	5.0	R	$\sqrt{3}$	1	1	2.9	2.9	$\infty$
<b>Phantom and set-up</b>										
18	Phantom uncertainty	B	4.0	R	$\sqrt{3}$	1	1	2.3	2.3	$\infty$

19	Liquid conductivity (target)	B	5.0	R	$\sqrt{3}$	0.64	0.43	1.8	1.2	$\infty$
20	Liquid conductivity (meas.)	A	2.06	N	1	0.64	0.43	1.32	0.89	43
21	Liquid permittivity (target)	B	5.0	R	$\sqrt{3}$	0.6	0.49	1.7	1.4	$\infty$
22	Liquid permittivity (meas.)	A	1.6	N	1	0.6	0.49	1.0	0.8	521
Combined standard uncertainty		$u_c = \sqrt{\sum_{i=1}^{22} c_i^2 u_i^2}$						10.4	10.3	257
Expanded uncertainty (confidence interval of 95 %)		$u_e = 2u_c$						20.8	20.6	

### 16.4 Measurement Uncertainty for Fast SAR Tests (3~6GHz)

No.	Error Description	Type	Uncertainty value	Probably Distribution	Div.	(Ci) 1g	(Ci) 10g	Std. Unc. (1g)	Std. Unc. (10g)	Degree of freedom
<b>Measurement system</b>										
1	Probe calibration	B	6.55	N	1	1	1	6.55	6.55	$\infty$
2	Isotropy	B	4.7	R	$\sqrt{3}$	0.7	0.7	1.9	1.9	$\infty$
3	Boundary effect	B	2.0	R	$\sqrt{3}$	1	1	1.2	1.2	$\infty$
4	Linearity	B	4.7	R	$\sqrt{3}$	1	1	2.7	2.7	$\infty$
5	Detection limit	B	1.0	R	$\sqrt{3}$	1	1	0.6	0.6	$\infty$
6	Readout electronics	B	0.3	R	$\sqrt{3}$	1	1	0.3	0.3	$\infty$
7	Response time	B	0.8	R	$\sqrt{3}$	1	1	0.5	0.5	$\infty$
8	Integration time	B	2.6	R	$\sqrt{3}$	1	1	1.5	1.5	$\infty$
9	RF ambient conditions-noise	B	0	R	$\sqrt{3}$	1	1	0	0	$\infty$
10	RFambient conditions-reflection	B	0	R	$\sqrt{3}$	1	1	0	0	$\infty$
11	Probe positioned mech. Restrictions	B	0.8	R	$\sqrt{3}$	1	1	0.5	0.5	$\infty$
12	Probe positioning with respect to phantom shell	B	6.7	R	$\sqrt{3}$	1	1	3.9	3.9	$\infty$
13	Post-processing	B	1.0	R	$\sqrt{3}$	1	1	0.6	0.6	$\infty$
14	Fast SAR z-Approximation	B	14.0	R	$\sqrt{3}$	1	1	8.1	8.1	$\infty$
<b>Test sample related</b>										
15	Test sample positioning	A	3.3	N	1	1	1	3.3	3.3	71



16	Device holder uncertainty	A	3.4	N	1	1	1	3.4	3.4	5
17	Drift of output power	B	5.0	R	$\sqrt{3}$	1	1	2.9	2.9	$\infty$
<b>Phantom and set-up</b>										
18	Phantom uncertainty	B	4.0	R	$\sqrt{3}$	1	1	2.3	2.3	$\infty$
19	Liquid conductivity (target)	B	5.0	R	$\sqrt{3}$	0.64	0.43	1.8	1.2	$\infty$
20	Liquid conductivity (meas.)	A	2.06	N	1	0.64	0.43	1.32	0.89	43
21	Liquid permittivity (target)	B	5.0	R	$\sqrt{3}$	0.6	0.49	1.7	1.4	$\infty$
22	Liquid permittivity (meas.)	A	1.6	N	1	0.6	0.49	1.0	0.8	521
Combined standard uncertainty		$u_c = \sqrt{\sum_{i=1}^{22} c_i^2 u_i^2}$						13.5	13.4	257
Expanded uncertainty (confidence interval of 95 %)		$u_e = 2u_c$						27.0	26.8	

## 17 MAIN TEST INSTRUMENTS

**Table 17.1: List of Main Instruments**

No.	Name	Type	Serial Number	Calibration Date	Valid Period
01	Network analyzer	N5239A	MY46110673	January 24, 2020	One year
02	Power meter	NRP2	101919	May 12, 2020	One year
03	Power sensor	NRP-Z91	101547		
04	Signal Generator	E4438C	MY49070393	January 4, 2020	One Year
05	Amplifier	60S1G4	0331848	No Calibration Requested	
06	BTS	CMW500	129942	February 10, 2020	One year
07	E-field Probe	SPEAG EX3DV4	3617	Jan 30, 2020	One year
08	DAE	SPEAG DAE4	777	January 8, 2020	One year
09	Dipole Validation Kit	SPEAG D750V3	1017	July 24,2020	One year
10	Dipole Validation Kit	SPEAG D835V2	4d069	July 24,,2020	One year
11	Dipole Validation Kit	SPEAG D1750V2	1003	July 24, 2020	One year
12	Dipole Validation Kit	SPEAG D1900V2	5d101	July 28,2020	One year
13	Dipole Validation Kit	SPEAG D2450V2	853	July 21,2020	One year

\*\*\*END OF REPORT BODY\*\*\*

## ANNEX A Graph Results

### GSM850\_CH128 Right Cheek

Date: 9/13/2020

Electronics: DAE4 Sn777

Medium: head 835 MHz

Medium parameters used:  $f = 824.2$ ;  $\sigma = 0.888$  mho/m;  $\epsilon_r = 40.93$ ;  $\rho = 1000$  kg/m<sup>3</sup>

Ambient Temperature: 22.5°C, Liquid Temperature: 22.3°C

Communication System: GSM850 824.2 Duty Cycle: 1: 8.3

Probe: EX3DV4 – SN3617 ConvF(9.66,9.66,9.66)

**Area Scan (71x121x1):** Interpolated grid: dx=1.000 mm, dy=1.000 mm

Maximum value of SAR (interpolated) = 0.295 W/kg

**Zoom Scan (7x7x7)/Cube 0:** Measurement grid: dx=5mm, dy=5mm, dz=5mm

Reference Value = 6.692 V/m; Power Drift = 0.11 dB

Peak SAR (extrapolated) = 0.328 W/kg

**SAR(1 g) = 0.259 W/kg; SAR(10 g) = 0.205 W/kg**

Maximum value of SAR (measured) = 0.301 W/kg

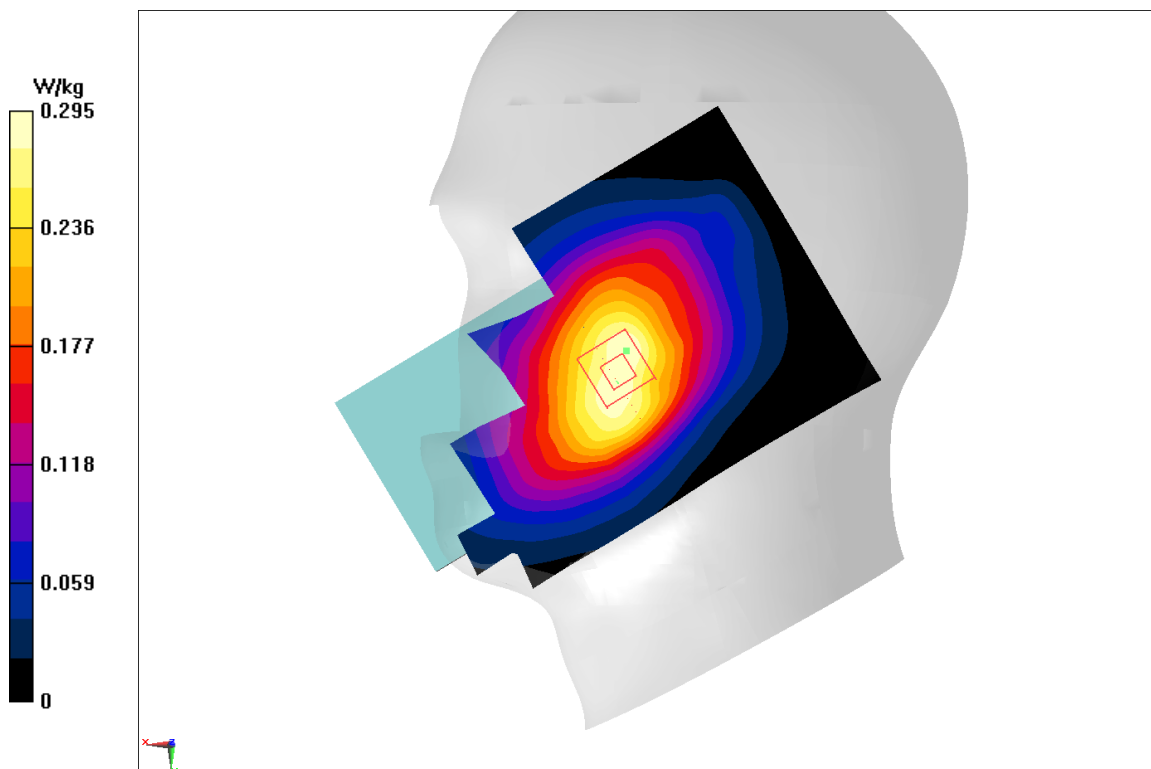

Fig A.1

**GSM850\_CH190 Rear**

Date: 9/13/2020

Electronics: DAE4 Sn777

Medium: head 835 MHz

Medium parameters used:  $f = 836.6$ ;  $\sigma = 0.9$  mho/m;  $\epsilon_r = 40.92$ ;  $\rho = 1000$  kg/m<sup>3</sup>

Ambient Temperature: 22.5°C, Liquid Temperature: 22.3°C

Communication System: GSM850 836.6 Duty Cycle: 1: 4

Probe: EX3DV4 – SN3617 ConvF(9.66,9.66,9.66)

**Area Scan (71x121x1):** Interpolated grid: dx=1.000 mm, dy=1.000 mm

Maximum value of SAR (interpolated) = 0.531 W/kg

**Zoom Scan (7x7x7)/Cube 0:** Measurement grid: dx=5mm, dy=5mm, dz=5mm

Reference Value = 15.49 V/m; Power Drift = -0.08 dB

Peak SAR (extrapolated) = 0.761 W/kg

**SAR(1 g) = 0.399 W/kg; SAR(10 g) = 0.219 W/kg**

Maximum value of SAR (measured) = 0.599 W/kg

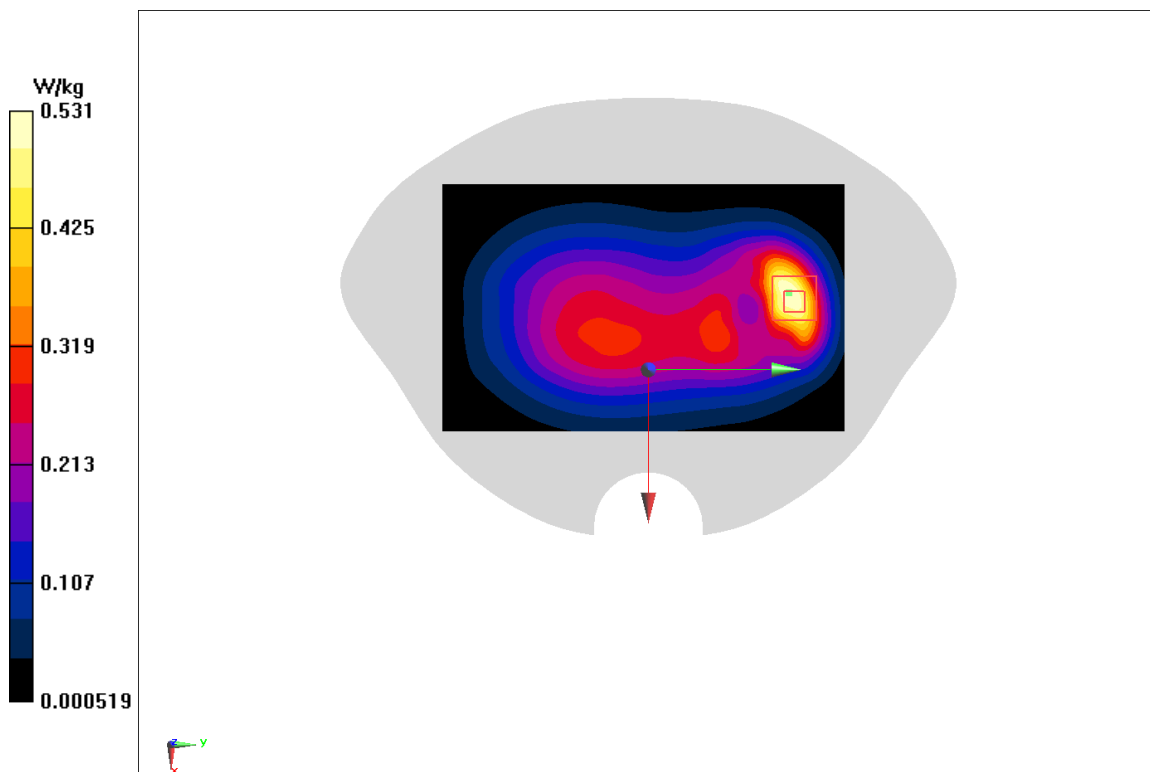

**Fig A.2**

### PCS1900\_CH661 Right Cheek

Date: 9/15/2020

Electronics: DAE4 Sn777

Medium: head 1900 MHz

Medium parameters used:  $f = 1880$ ;  $\sigma = 1.389$  mho/m;  $\epsilon_r = 40.76$ ;  $\rho = 1000$  kg/m<sup>3</sup>

Ambient Temperature: 22.5°C, Liquid Temperature: 22.3°C

Communication System: PCS1900 1880 Duty Cycle: 1: 8.3

Probe: EX3DV4 – SN3617 ConvF(8.14,8.14,8.14)

**Area Scan (71x121x1):** Interpolated grid: dx=1.000 mm, dy=1.000 mm

Maximum value of SAR (interpolated) = 0.0543 W/kg

**Zoom Scan (7x7x7)/Cube 0:** Measurement grid: dx=5mm, dy=5mm, dz=5mm

Reference Value = 3.108 V/m; Power Drift = 0.12 dB

Peak SAR (extrapolated) = 0.059 W/kg

**SAR(1 g) = 0.039 W/kg; SAR(10 g) = 0.025 W/kg**

Maximum value of SAR (measured) = 0.0518 W/kg

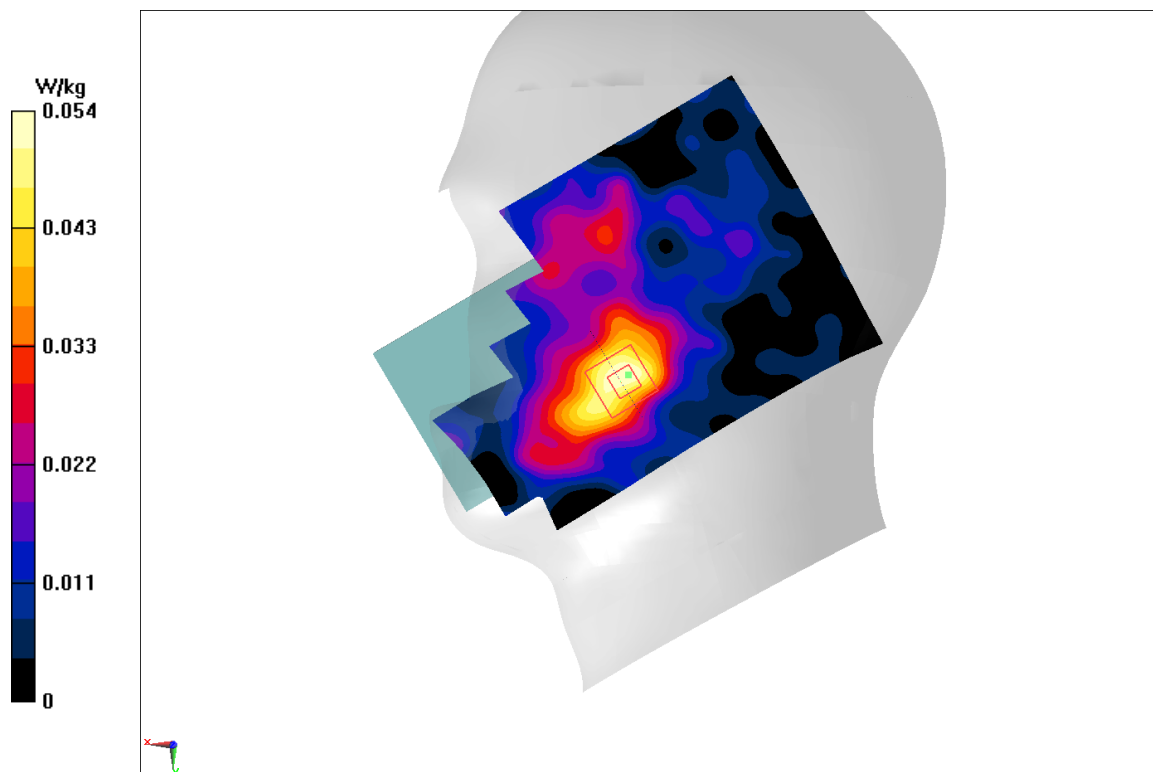

Fig A.3

**PCS1900\_CH512 Bottom**

Date: 9/15/2020

Electronics: DAE4 Sn777

Medium: head 1900 MHz

Medium parameters used:  $f = 1850.2$ ;  $\sigma = 1.36$  mho/m;  $\epsilon_r = 40.8$ ;  $\rho = 1000$  kg/m<sup>3</sup>

Ambient Temperature: 22.5°C, Liquid Temperature: 22.3°C

Communication System: PCS1900 1850.2 Duty Cycle: 1: 2.67

Probe: EX3DV4 – SN3617 ConvF(8.14,8.14,8.14)

**Area Scan (71x121x1):** Interpolated grid: dx=1.000 mm, dy=1.000 mm

Maximum value of SAR (interpolated) = 1.14 W/kg

**Zoom Scan (7x7x7)/Cube 0:** Measurement grid: dx=5mm, dy=5mm, dz=5mm

Reference Value = 15.94 V/m; Power Drift = 0.02 dB

Peak SAR (extrapolated) = 1.22 W/kg

**SAR(1 g) = 0.774 W/kg; SAR(10 g) = 0.418 W/kg**

Maximum value of SAR (measured) = 1.06 W/kg

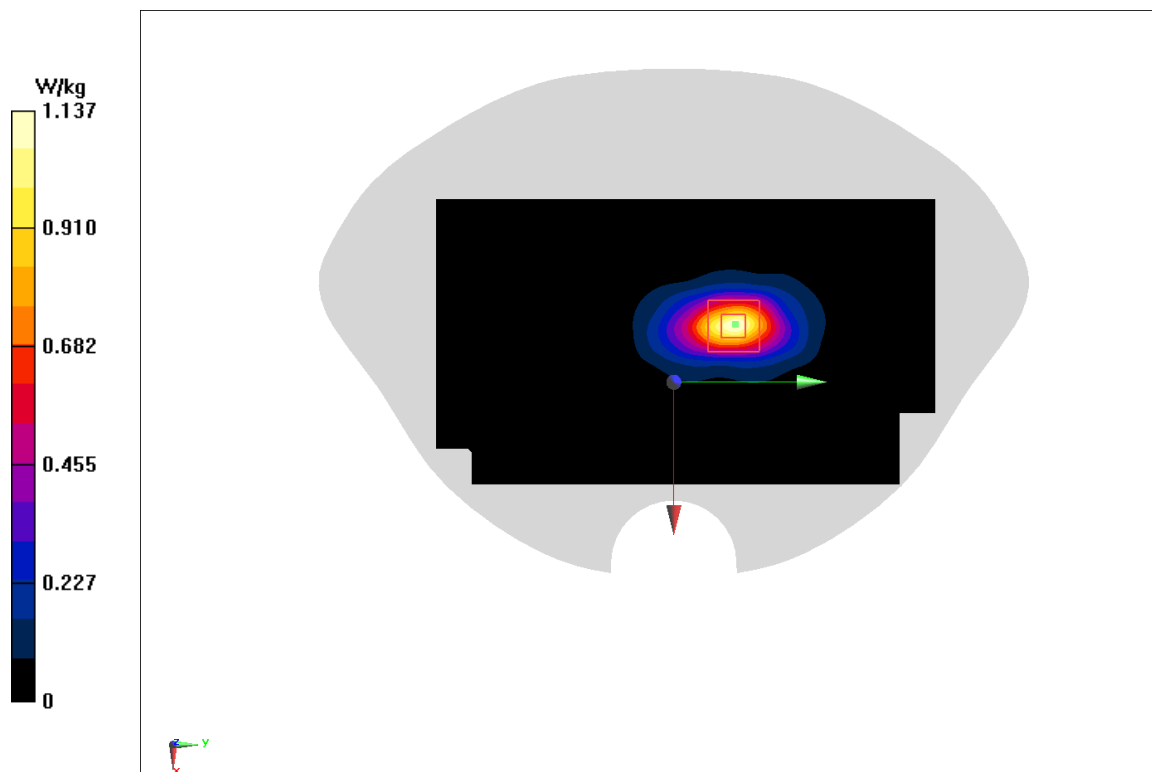
**Fig A.4**

**PCS1900\_CH512 Rear**

Date: 9/15/2020

Electronics: DAE4 Sn777

Medium: head 1900 MHz

Medium parameters used:  $f = 1850.2$ ;  $\sigma = 1.36$  mho/m;  $\epsilon_r = 40.8$ ;  $\rho = 1000$  kg/m<sup>3</sup>

Ambient Temperature: 22.5°C, Liquid Temperature: 22.3°C

Communication System: PCS1900 1850.2 Duty Cycle: 1: 4

Probe: EX3DV4 – SN3617 ConvF(8.14,8.14,8.14)

**Area Scan (71x121x1):** Interpolated grid: dx=1.000 mm, dy=1.000 mm

Maximum value of SAR (interpolated) = 0.654 W/kg

**Zoom Scan (7x7x7)/Cube 0:** Measurement grid: dx=5mm, dy=5mm, dz=5mm

Reference Value = 7.406 V/m; Power Drift = -0.05 dB

Peak SAR (extrapolated) = 0.767 W/kg

**SAR(1 g) = 0.462 W/kg; SAR(10 g) = 0.264 W/kg**

Maximum value of SAR (measured) = 0.64 W/kg

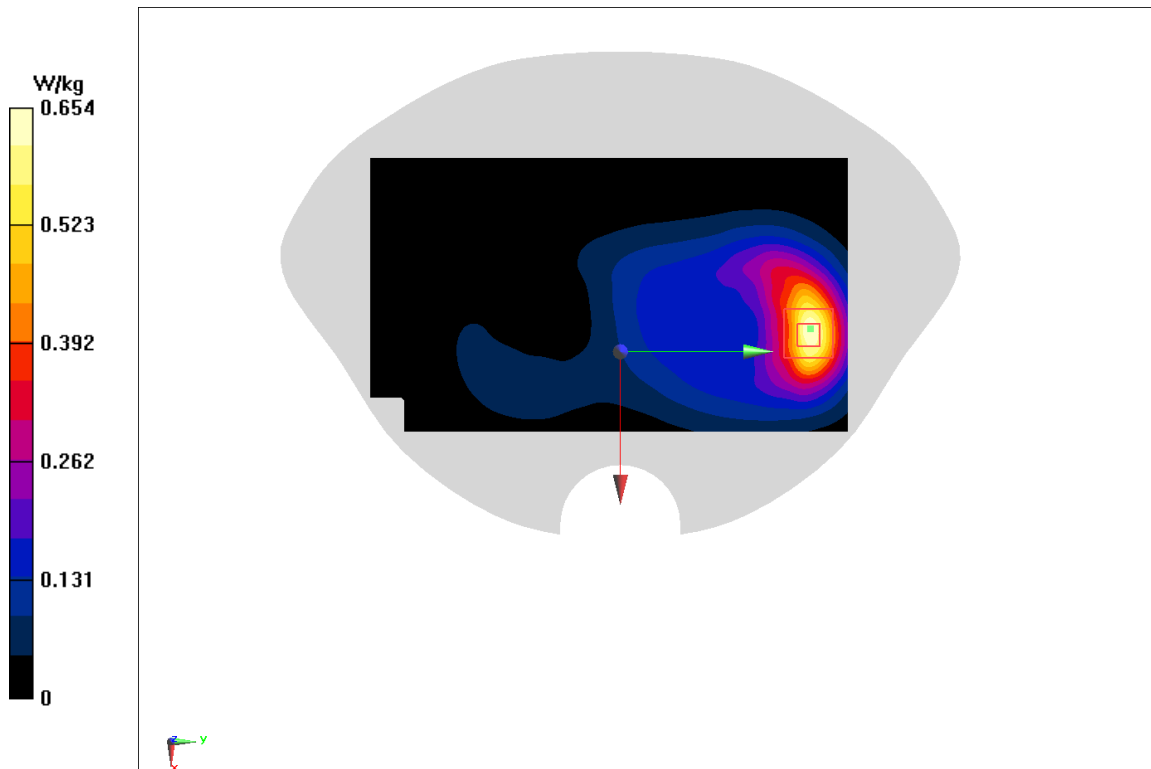

**Fig A.5**

**WCDMA1900-BII\_CH9262 Right Cheek**

Date: 9/15/2020

Electronics: DAE4 Sn777

Medium: head 1900 MHz

Medium parameters used:  $f = 1852.4$ ;  $\sigma = 1.362$  mho/m;  $\epsilon_r = 40.8$ ;  $\rho = 1000$  kg/m<sup>3</sup>

Ambient Temperature: 22.5°C, Liquid Temperature: 22.3°C

Communication System: WCDMA1900-BII 1852.4 Duty Cycle: 1: 1

Probe: EX3DV4 – SN3617 ConvF(8.14,8.14,8.14)

**Area Scan (71x121x1):** Interpolated grid: dx=1.000 mm, dy=1.000 mm

Maximum value of SAR (interpolated) = 0.174 W/kg

**Zoom Scan (7x7x7)/Cube 0:** Measurement grid: dx=5mm, dy=5mm, dz=5mm

Reference Value = 5.145 V/m; Power Drift = -0.07 dB

Peak SAR (extrapolated) = 0.186 W/kg

**SAR(1 g) = 0.131 W/kg; SAR(10 g) = 0.084 W/kg**

Maximum value of SAR (measured) = 0.167 W/kg

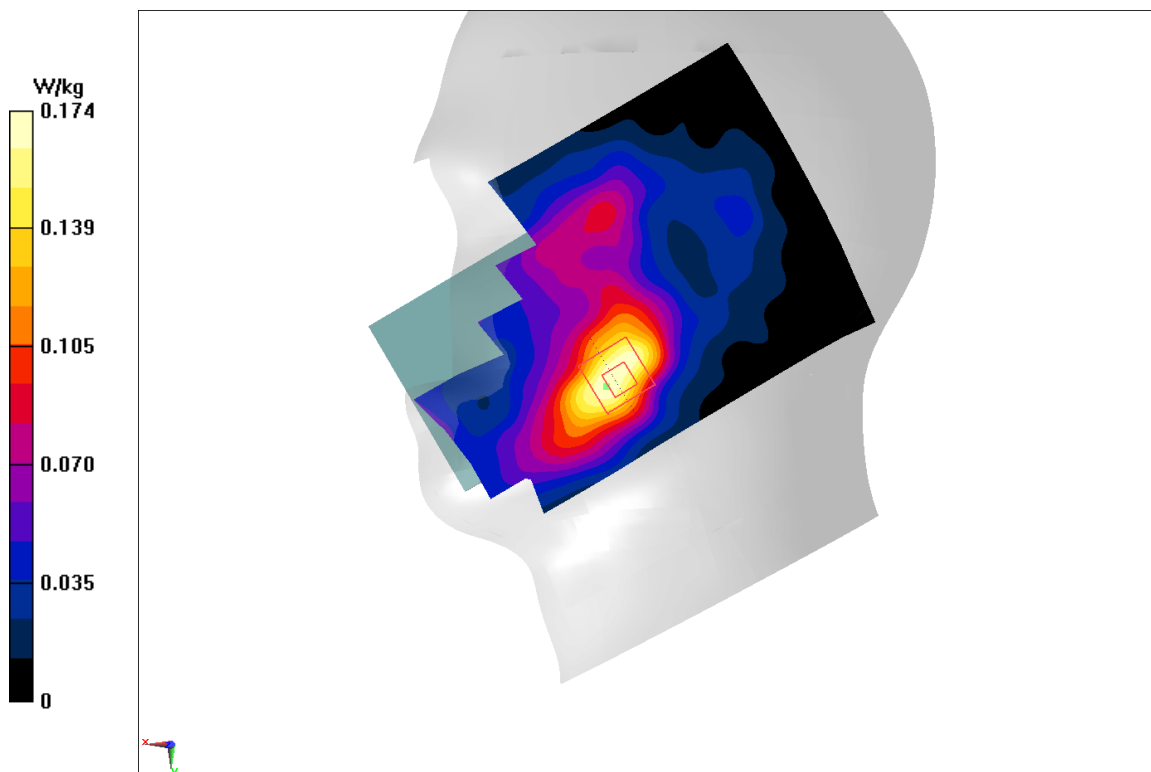
**Fig A.6**

**WCDMA1900-BII\_CH9538 Bottom**

Date: 9/15/2020

Electronics: DAE4 Sn777

Medium: head 1900 MHz

 Medium parameters used:  $f = 1907.6$ ;  $\sigma = 1.416$  mho/m;  $\epsilon_r = 40.73$ ;  $\rho = 1000$  kg/m<sup>3</sup>

Ambient Temperature: 22.5°C, Liquid Temperature: 22.3°C

Communication System: WCDMA1900-BII 1907.6 Duty Cycle: 1: 1

Probe: EX3DV4 – SN3617 ConvF(8.14,8.14,8.14)

**Area Scan (71x121x1):** Interpolated grid: dx=1.000 mm, dy=1.000 mm

Maximum value of SAR (interpolated) = 1.36 W/kg

**Zoom Scan (7x7x7)/Cube 0:** Measurement grid: dx=5mm, dy=5mm, dz=5mm

Reference Value = 14.72 V/m; Power Drift = -0.13 dB

Peak SAR (extrapolated) = 1.47 W/kg

**SAR(1 g) = 0.892 W/kg; SAR(10 g) = 0.465 W/kg**

Maximum value of SAR (measured) = 1.26 W/kg

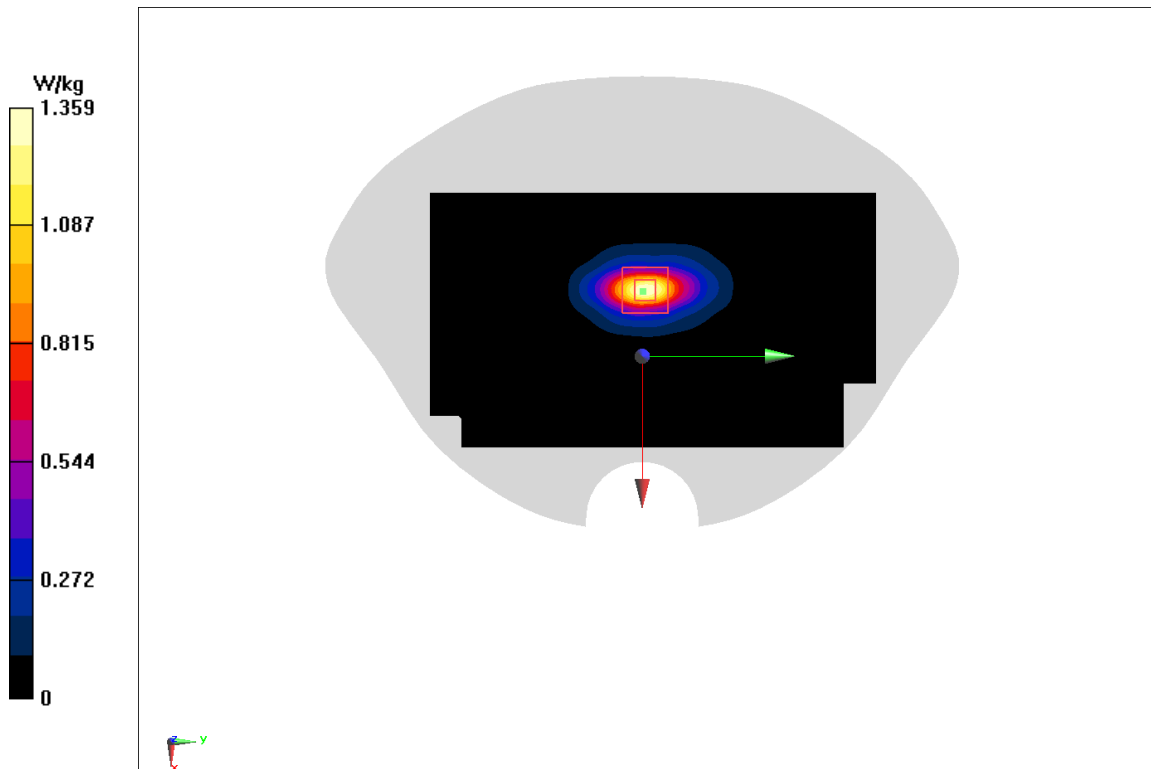
**Fig A.7**



**WCDMA1900-BII\_CH9262 Rear**

Date: 9/15/2020

Electronics: DAE4 Sn777

Medium: head 1900 MHz

Medium parameters used:  $f = 1852.4$ ;  $\sigma = 1.362$  mho/m;  $\epsilon_r = 40.8$ ;  $\rho = 1000$  kg/m<sup>3</sup>

Ambient Temperature: 22.5°C, Liquid Temperature: 22.3°C

Communication System: WCDMA1900-BII 1852.4 Duty Cycle: 1: 1

Probe: EX3DV4 – SN3617 ConvF(8.14,8.14,8.14)

**Area Scan (71x121x1):** Interpolated grid: dx=1.000 mm, dy=1.000 mm

Maximum value of SAR (interpolated) = 0.774 W/kg

**Zoom Scan (7x7x7)/Cube 0:** Measurement grid: dx=5mm, dy=5mm, dz=5mm

Reference Value = 9.425 V/m; Power Drift = 0 dB

Peak SAR (extrapolated) = 0.858 W/kg

**SAR(1 g) = 0.551 W/kg; SAR(10 g) = 0.325 W/kg**

Maximum value of SAR (measured) = 0.714 W/kg

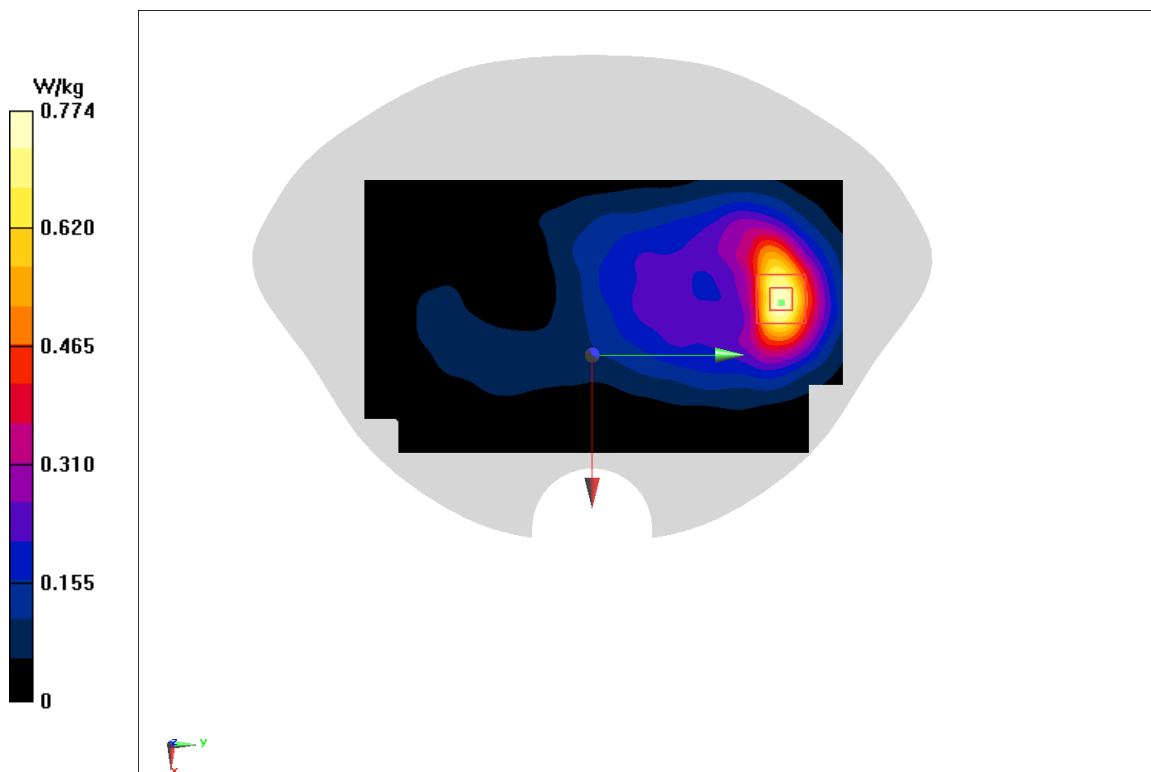
**Fig A.8**

**WCDMA1700-BIV\_CH1312 Right Cheek**

Date: 9/14/2020

Electronics: DAE4 Sn777

Medium: head 1750 MHz

Medium parameters used:  $f = 1712.4$ ;  $\sigma = 1.322$  mho/m;  $\epsilon_r = 39.74$ ;  $\rho = 1000$  kg/m<sup>3</sup>

Ambient Temperature: 22.5°C, Liquid Temperature: 22.3°C

Communication System: WCDMA1700-BIV 1712.4 Duty Cycle: 1: 1

Probe: EX3DV4 – SN3617 ConvF(8.41,8.41,8.41)

**Area Scan (71x121x1):** Interpolated grid: dx=1.000 mm, dy=1.000 mm

Maximum value of SAR (interpolated) = 0.416 W/kg

**Zoom Scan (7x7x7)/Cube 0:** Measurement grid: dx=5mm, dy=5mm, dz=5mm

Reference Value = 7.741 V/m; Power Drift = 0.09 dB

Peak SAR (extrapolated) = 0.446 W/kg

**SAR(1 g) = 0.321 W/kg; SAR(10 g) = 0.215 W/kg**

Maximum value of SAR (measured) = 0.392 W/kg

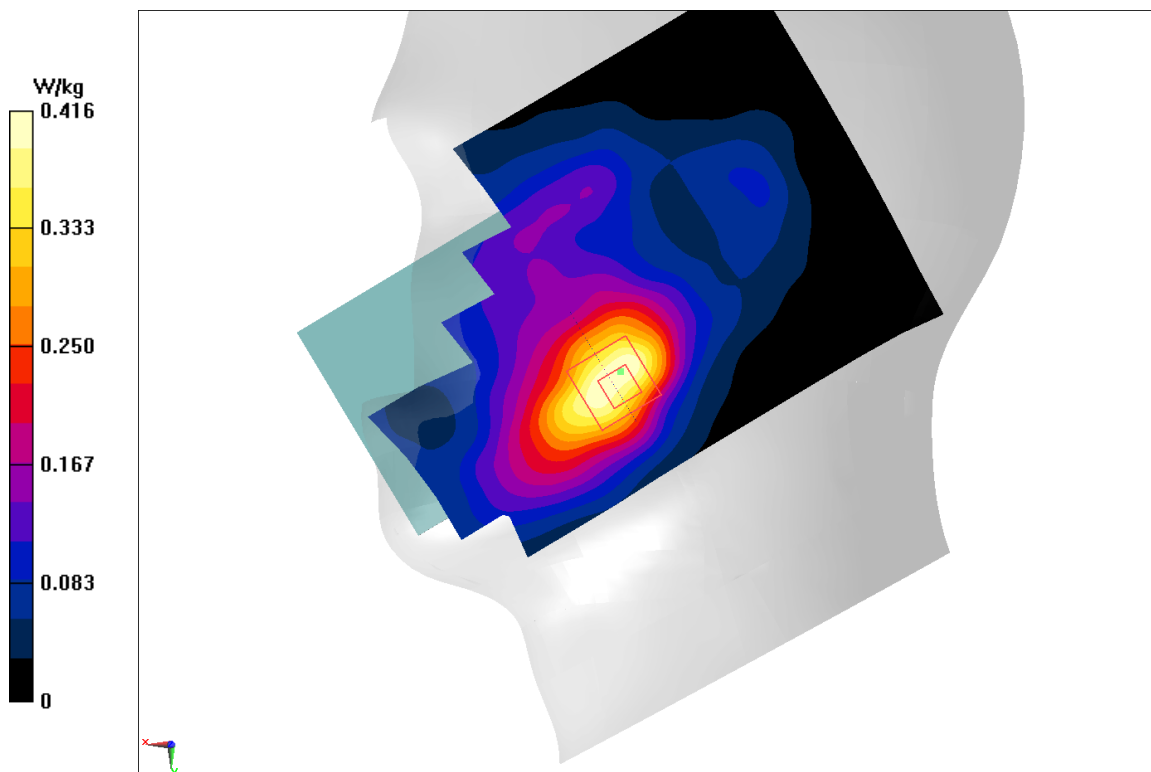
**Fig A.9**

**WCDMA1700-BIV\_CH1513 Bottom**

Date: 9/14/2020

Electronics: DAE4 Sn777

Medium: head 1750 MHz

Medium parameters used:  $f = 1752.6$ ;  $\sigma = 1.361$  mho/m;  $\epsilon_r = 39.69$ ;  $\rho = 1000$  kg/m<sup>3</sup>

Ambient Temperature: 22.5°C, Liquid Temperature: 22.3°C

Communication System: WCDMA1700-BIV 1752.6 Duty Cycle: 1: 1

Probe: EX3DV4 – SN3617 ConvF(8.41,8.41,8.41)

**Area Scan (71x121x1):** Interpolated grid: dx=1.000 mm, dy=1.000 mm

Maximum value of SAR (interpolated) = 1.25 W/kg

**Zoom Scan (7x7x7)/Cube 0:** Measurement grid: dx=5mm, dy=5mm, dz=5mm

Reference Value = 21.12 V/m; Power Drift = -0.06 dB

Peak SAR (extrapolated) = 1.44 W/kg

**SAR(1 g) = 0.87 W/kg; SAR(10 g) = 0.461 W/kg**

Maximum value of SAR (measured) = 1.21 W/kg

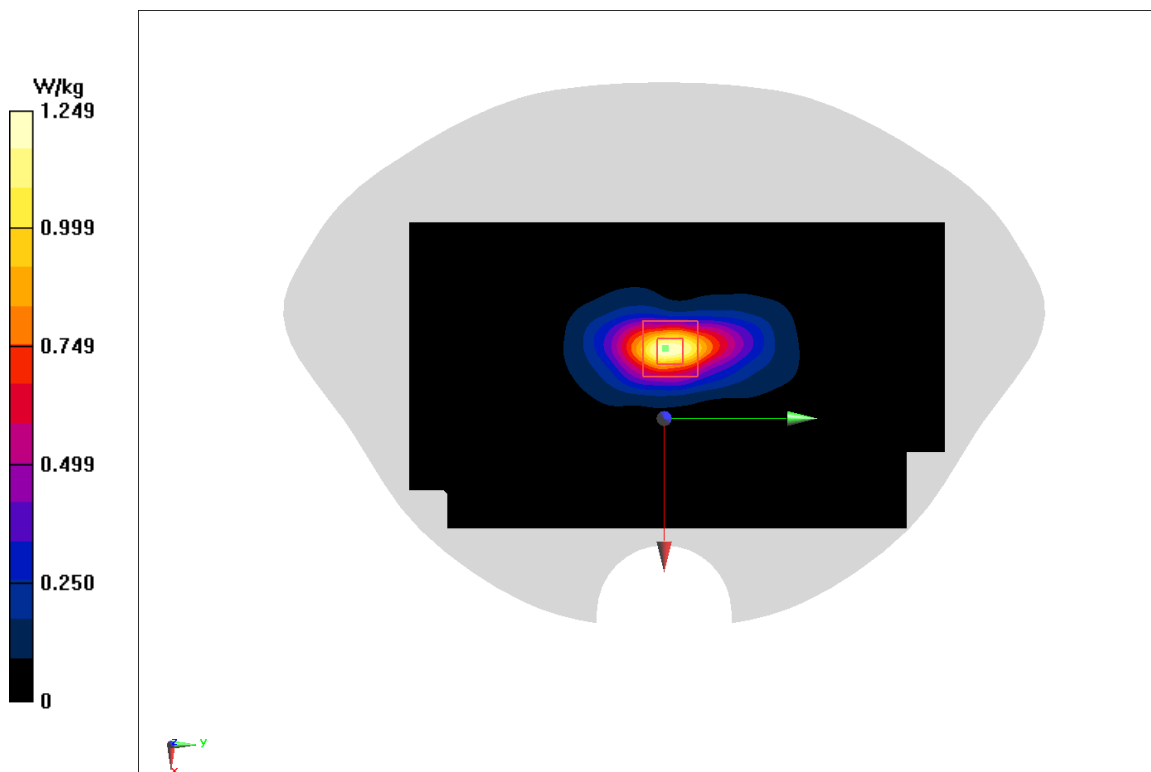
**Fig A.10**

**WCDMA1700-BIV\_CH1412 Front**

Date: 9/14/2020

Electronics: DAE4 Sn777

Medium: head 1750 MHz

Medium parameters used:  $f = 1732.5$ ;  $\sigma = 1.341$  mho/m;  $\epsilon_r = 39.71$ ;  $\rho = 1000$  kg/m<sup>3</sup>

Ambient Temperature: 22.5°C, Liquid Temperature: 22.3°C

Communication System: WCDMA1700-BIV 1732.5 Duty Cycle: 1: 1

Probe: EX3DV4 – SN3617 ConvF(8.41,8.41,8.41)

**Area Scan (71x121x1):** Interpolated grid: dx=1.000 mm, dy=1.000 mm

Maximum value of SAR (interpolated) = 0.591 W/kg

**Zoom Scan (7x7x7)/Cube 0:** Measurement grid: dx=5mm, dy=5mm, dz=5mm

Reference Value = 7.077 V/m; Power Drift = -0.13 dB

Peak SAR (extrapolated) = 0.695 W/kg

**SAR(1 g) = 0.446 W/kg; SAR(10 g) = 0.268 W/kg**

Maximum value of SAR (measured) = 0.6 W/kg

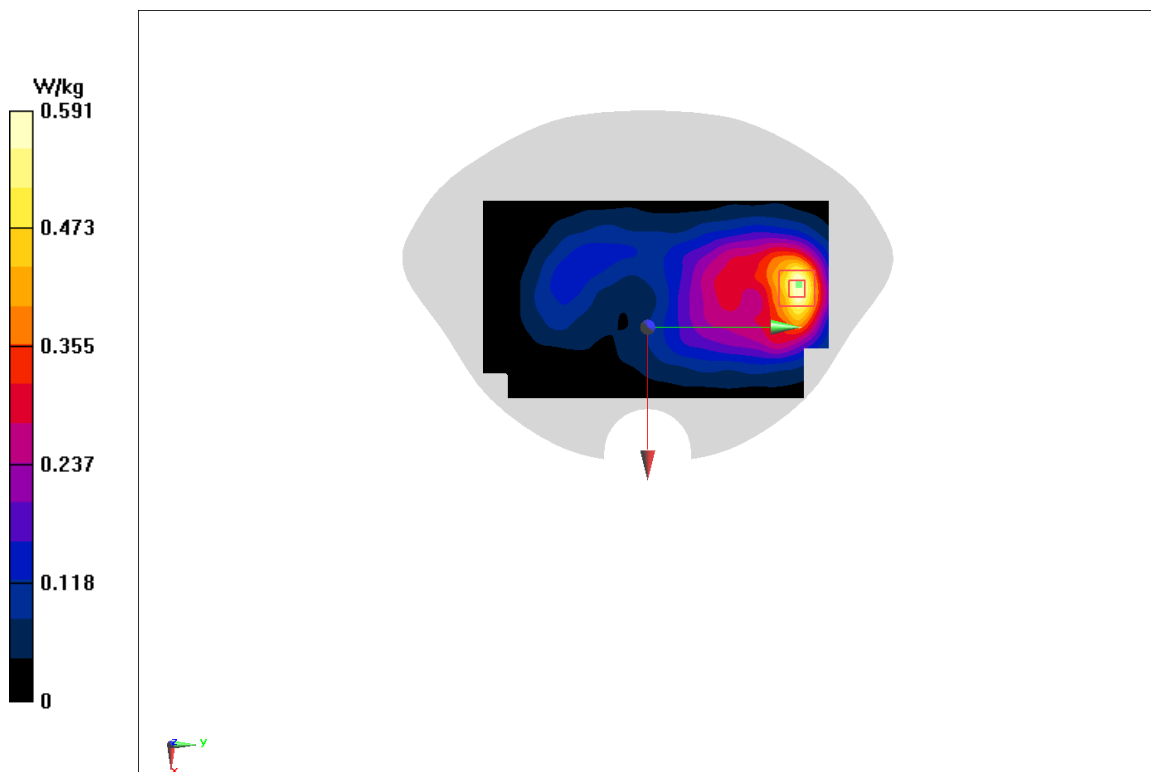
**Fig A.11**

**WCDMA850-BV\_CH4132 Right Cheek**

Date: 9/13/2020

Electronics: DAE4 Sn777

Medium: head 835 MHz

Medium parameters used:  $f = 826.4$ ;  $\sigma = 0.889$  mho/m;  $\epsilon_r = 40.93$ ;  $\rho = 1000$  kg/m<sup>3</sup>

Ambient Temperature: 22.5°C, Liquid Temperature: 22.3°C

Communication System: WCDMA850-BV 826.4 Duty Cycle: 1: 1

Probe: EX3DV4 – SN3617 ConvF(9.66,9.66,9.66)

**Area Scan (71x121x1):** Interpolated grid: dx=1.000 mm, dy=1.000 mm

Maximum value of SAR (interpolated) = 0.86 W/kg

**Zoom Scan (7x7x7)/Cube 0:** Measurement grid: dx=5mm, dy=5mm, dz=5mm

Reference Value = 31.17 V/m; Power Drift = 0.05 dB

Peak SAR (extrapolated) = 0.944 W/kg

**SAR(1 g) = 0.631 W/kg; SAR(10 g) = 0.442 W/kg**

Maximum value of SAR (measured) = 0.827 W/kg

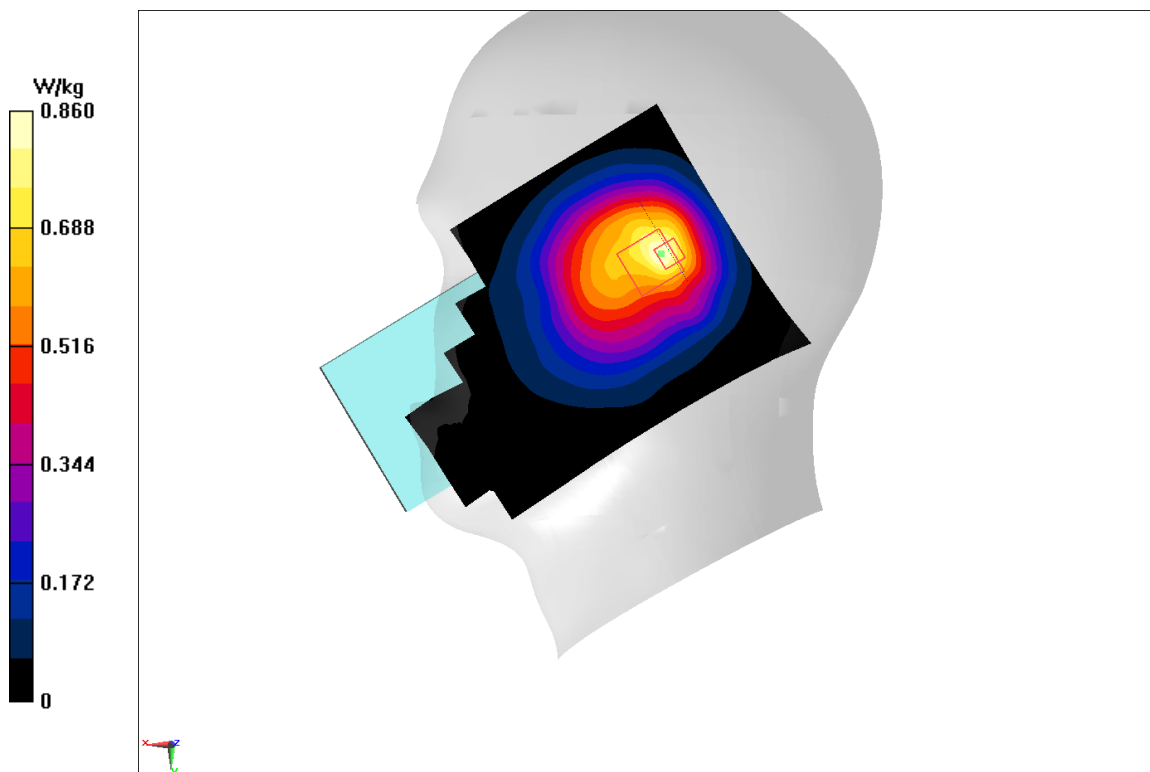

**Fig A.12**

**WCDMA850-BV\_CH4183 Rear**

Date: 9/13/2020

Electronics: DAE4 Sn777

Medium: head 835 MHz

Medium parameters used:  $f = 836.6$ ;  $\sigma = 0.9$  mho/m;  $\epsilon_r = 40.92$ ;  $\rho = 1000$  kg/m<sup>3</sup>

Ambient Temperature: 22.5°C, Liquid Temperature: 22.3°C

Communication System: WCDMA850-BV 836.6 Duty Cycle: 1: 1

Probe: EX3DV4 – SN3617 ConvF(9.66,9.66,9.66)

**Area Scan (71x121x1):** Interpolated grid: dx=1.000 mm, dy=1.000 mm

Maximum value of SAR (interpolated) = 0.197 W/kg

**Zoom Scan (7x7x7)/Cube 0:** Measurement grid: dx=5mm, dy=5mm, dz=5mm

Reference Value = 14.4 V/m; Power Drift = 0.13 dB

Peak SAR (extrapolated) = 0.187 W/kg

**SAR(1 g) = 0.16 W/kg; SAR(10 g) = 0.128 W/kg**

Maximum value of SAR (measured) = 0.179 W/kg

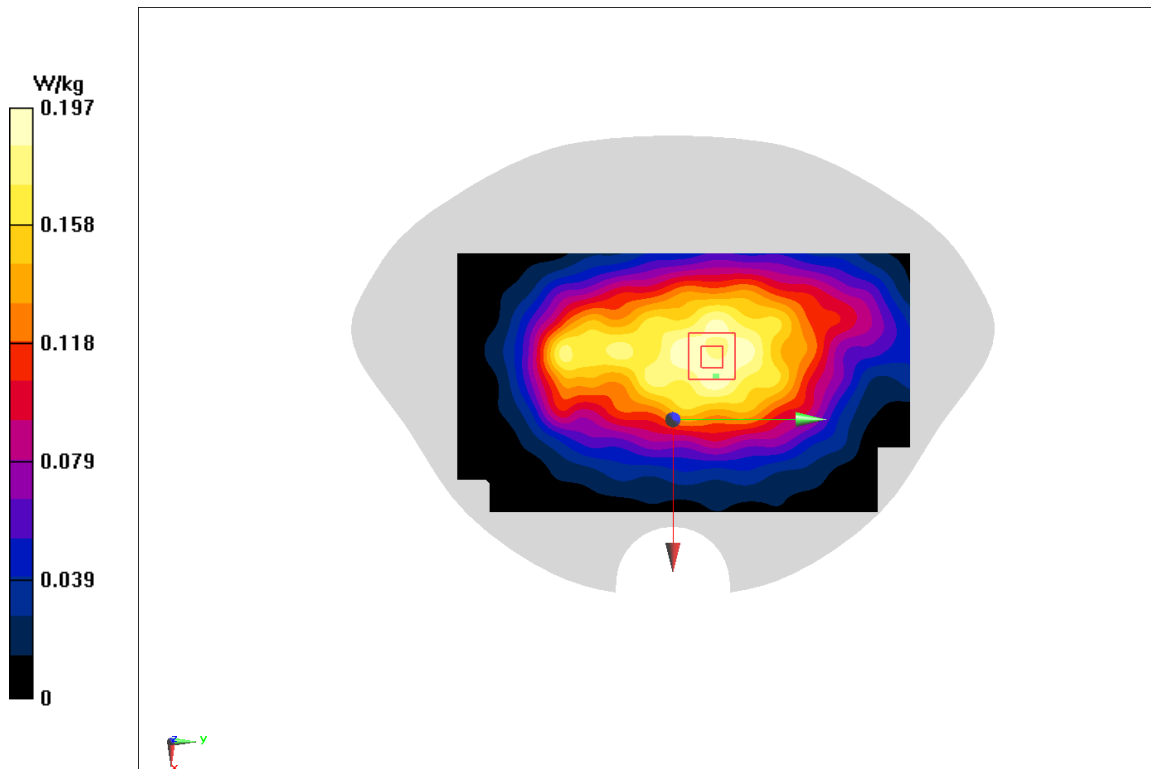

**Fig A.13**

**LTE1900-FDD2\_CH19100 Left Cheek**

Date: 9/15/2020

Electronics: DAE4 Sn777

Medium: head 1900 MHz

 Medium parameters used:  $f = 1900$  MHz;  $\sigma = 1.408$  mho/m;  $\epsilon_r = 40.74$ ;  $\rho = 1000$  kg/m<sup>3</sup>

Ambient Temperature: 22.5°C, Liquid Temperature: 22.3°C

Communication System: LTE1900-FDD2 1900 MHz Duty Cycle: 1: 1

Probe: EX3DV4 – SN3617 ConvF(8.14,8.14,8.14)

**Area Scan (71x121x1):** Interpolated grid: dx=1.000 mm, dy=1.000 mm

Maximum value of SAR (interpolated) = 0.145 W/kg

**Zoom Scan (7x7x7)/Cube 0:** Measurement grid: dx=5mm, dy=5mm, dz=5mm

Reference Value = 3.469 V/m; Power Drift = 0.12 dB

Peak SAR (extrapolated) = 0.157 W/kg

**SAR(1 g) = 0.098 W/kg; SAR(10 g) = 0.050 W/kg**

Maximum value of SAR (measured) = 0.134 W/kg

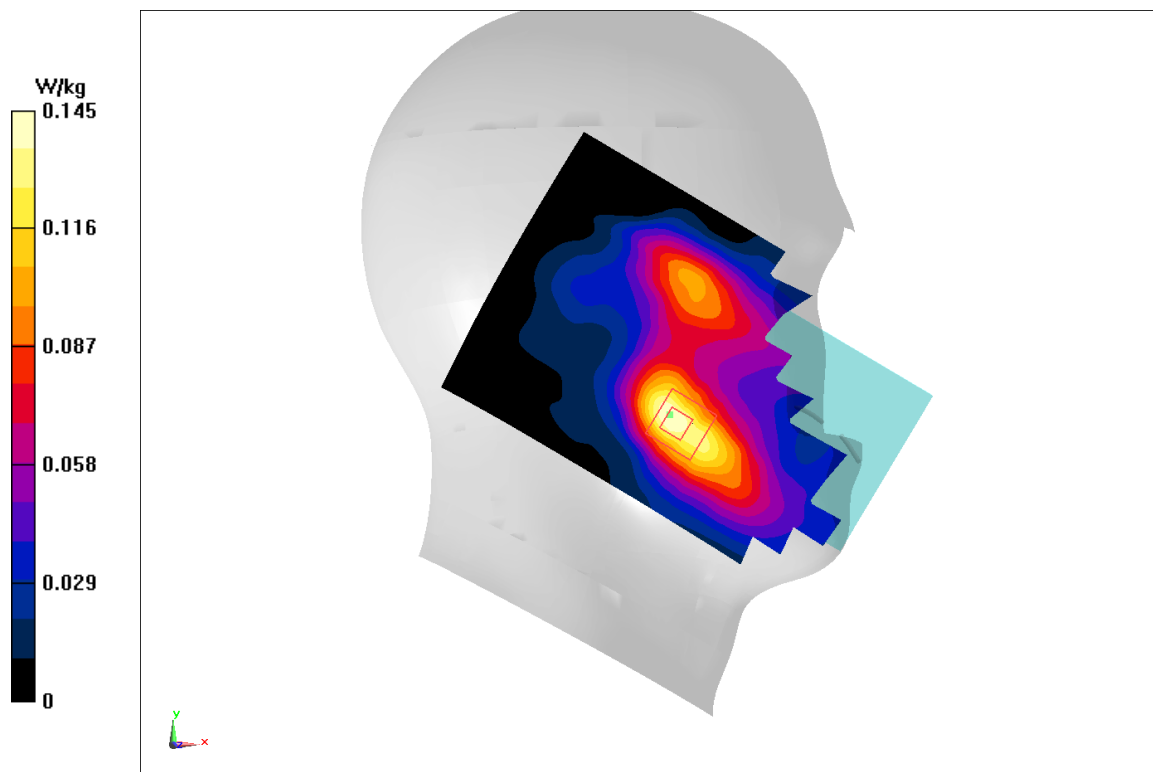
**Fig A.14**

**LTE1900-FDD2\_CH19100 Bottom**

Date: 9/15/2020

Electronics: DAE4 Sn777

Medium: head 1900 MHz

Medium parameters used:  $f = 1900$  MHz;  $\sigma = 1.408$  mho/m;  $\epsilon_r = 40.74$ ;  $\rho = 1000$  kg/m<sup>3</sup>

Ambient Temperature: 22.5°C, Liquid Temperature: 22.3°C

Communication System: LTE1900-FDD2 1900 MHz Duty Cycle: 1: 1

Probe: EX3DV4 – SN3617 ConvF(8.14,8.14,8.14)

**Area Scan (71x121x1):** Interpolated grid: dx=1.000 mm, dy=1.000 mm

Maximum value of SAR (interpolated) = 1.5 W/kg

**Zoom Scan (7x7x7)/Cube 0:** Measurement grid: dx=5mm, dy=5mm, dz=5mm

Reference Value = 30.83 V/m; Power Drift = -0.05 dB

Peak SAR (extrapolated) = 1.69 W/kg

**SAR(1 g) = 1.02 W/kg; SAR(10 g) = 0.533 W/kg**

Maximum value of SAR (measured) = 1.48 W/kg

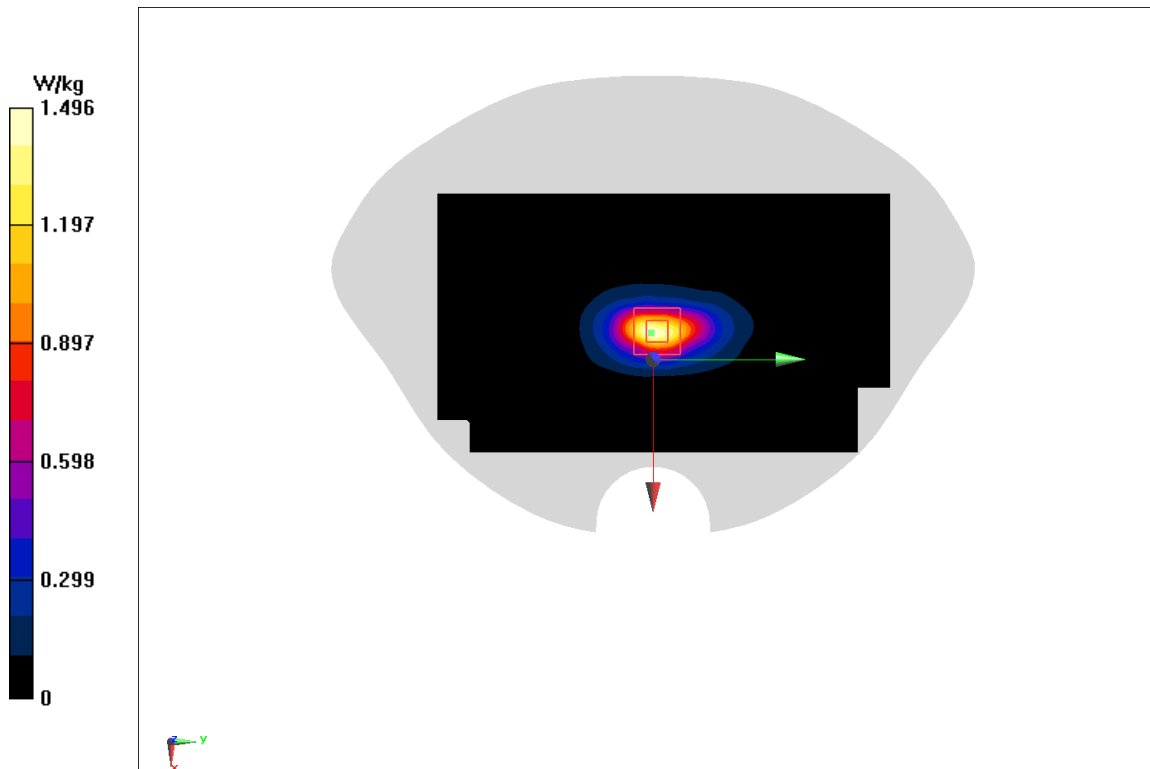

**Fig A.15**



**LTE1900-FDD2\_CH18700 Rear**

Date: 9/15/2020

Electronics: DAE4 Sn777

Medium: head 1900 MHz

Medium parameters used:  $f = 1860$  MHz;  $\sigma = 1.37$  mho/m;  $\epsilon_r = 40.79$ ;  $\rho = 1000$  kg/m<sup>3</sup>

Ambient Temperature: 22.5°C, Liquid Temperature: 22.3°C

Communication System: LTE1900-FDD2 1860 MHz Duty Cycle: 1: 1

Probe: EX3DV4 – SN3617 ConvF(8.14,8.14,8.14)

**Area Scan (71x121x1):** Interpolated grid: dx=1.000 mm, dy=1.000 mm

Maximum value of SAR (interpolated) = 1.03 W/kg

**Zoom Scan (7x7x7)/Cube 0:** Measurement grid: dx=5mm, dy=5mm, dz=5mm

Reference Value = 7.34 V/m; Power Drift = -0.07 dB

Peak SAR (extrapolated) = 1.25 W/kg

**SAR(1 g) = 0.745 W/kg; SAR(10 g) = 0.425 W/kg**

Maximum value of SAR (measured) = 1.07 W/kg

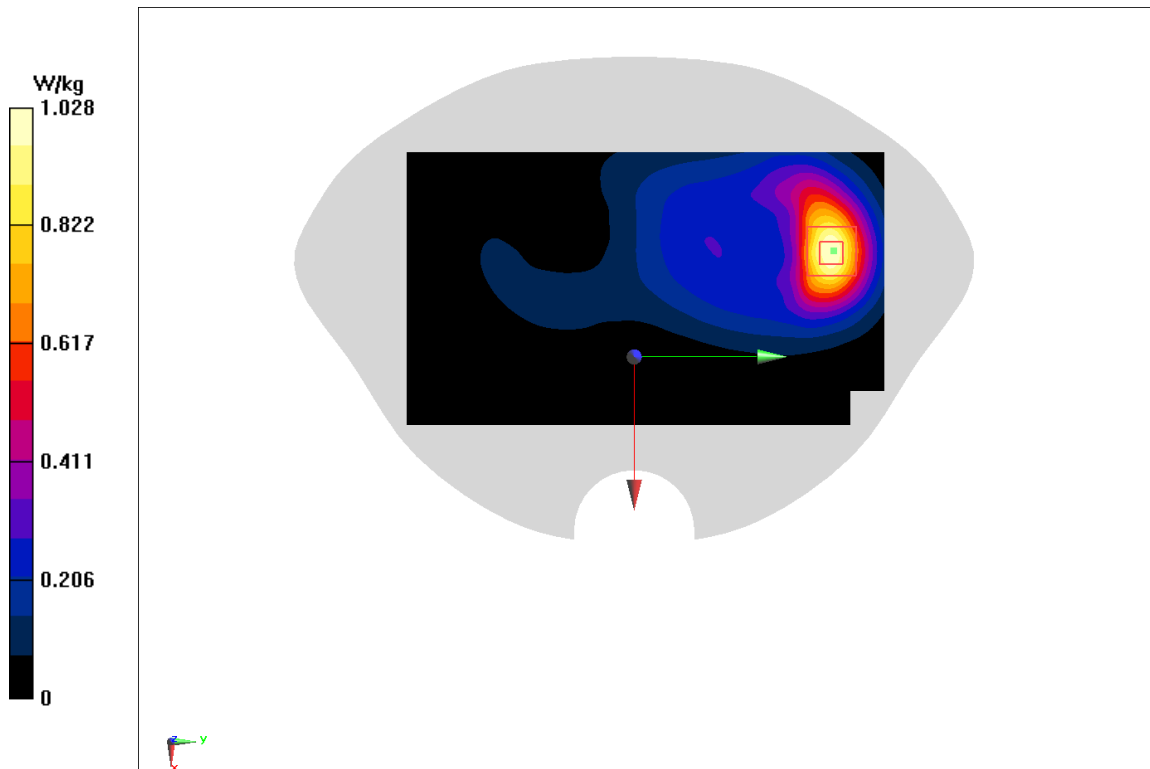

**Fig A.16**

**LTE850-FDD5\_CH20600 Right Cheek**

Date: 9/13/2020

Electronics: DAE4 Sn777

Medium: head 835 MHz

Medium parameters used:  $f = 844 \text{ MHz}$ ;  $\sigma = 0.907 \text{ mho/m}$ ;  $\epsilon_r = 40.91$ ;  $\rho = 1000 \text{ kg/m}^3$

Ambient Temperature:  $22.5^\circ\text{C}$ , Liquid Temperature:  $22.3^\circ\text{C}$

Communication System: LTE850-FDD5 844 MHz Duty Cycle: 1: 1

Probe: EX3DV4 – SN3617 ConvF(9.66,9.66,9.66)

**Area Scan (71x121x1):** Interpolated grid:  $dx=1.000 \text{ mm}$ ,  $dy=1.000 \text{ mm}$

Maximum value of SAR (interpolated) =  $1.3 \text{ W/kg}$

**Zoom Scan (7x7x7)/Cube 0:** Measurement grid:  $dx=5\text{mm}$ ,  $dy=5\text{mm}$ ,  $dz=5\text{mm}$

Reference Value =  $33.91 \text{ V/m}$ ; Power Drift =  $-0.03 \text{ dB}$

Peak SAR (extrapolated) =  $1.77 \text{ W/kg}$

**SAR(1 g) =  $0.998 \text{ W/kg}$ ; SAR(10 g) =  $0.653 \text{ W/kg}$**

Maximum value of SAR (measured) =  $1.45 \text{ W/kg}$

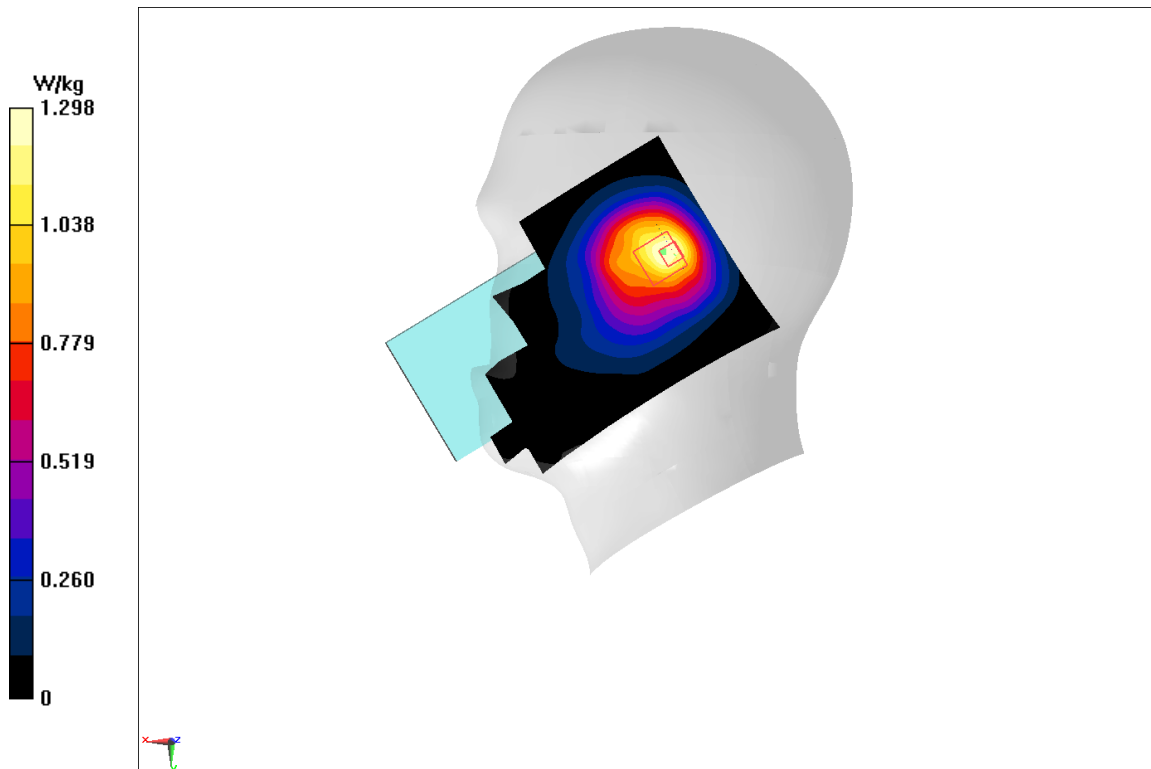

**Fig A.17**

**LTE850-FDD5\_CH20525 Rear**

Date: 9/13/2020

Electronics: DAE4 Sn777

Medium: head 835 MHz

Medium parameters used:  $f = 836.5$  MHz;  $\sigma = 0.899$  mho/m;  $\epsilon_r = 40.92$ ;  $\rho = 1000$  kg/m<sup>3</sup>

Ambient Temperature: 22.5°C, Liquid Temperature: 22.3°C

Communication System: LTE850-FDD5 836.5 MHz Duty Cycle: 1: 1

Probe: EX3DV4 – SN3617 ConvF(9.66,9.66,9.66)

**Area Scan (71x121x1):** Interpolated grid: dx=1.000 mm, dy=1.000 mm

Maximum value of SAR (interpolated) = 0.44 W/kg

**Zoom Scan (7x7x7)/Cube 0:** Measurement grid: dx=5mm, dy=5mm, dz=5mm

Reference Value = 21.16 V/m; Power Drift = -0.07 dB

Peak SAR (extrapolated) = 0.48 W/kg

**SAR(1 g) = 0.331 W/kg; SAR(10 g) = 0.219 W/kg**

Maximum value of SAR (measured) = 0.428 W/kg

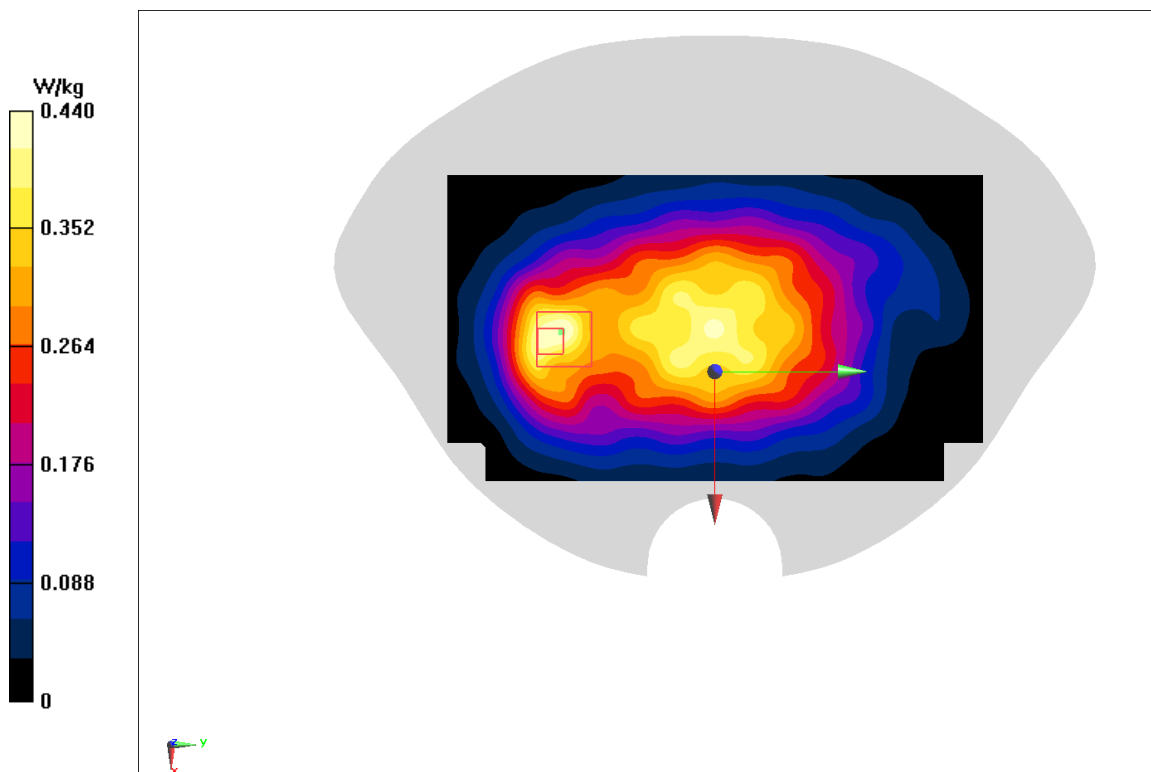

**Fig A.18**

**LTE700-FDD12\_CH23095 Left Cheek**

Date: 9/12/2020

Electronics: DAE4 Sn777

Medium: head 750 MHz

Medium parameters used:  $f = 707.5$  MHz;  $\sigma = 0.85$  mho/m;  $\epsilon_r = 41.33$ ;  $\rho = 1000$  kg/m<sup>3</sup>

Ambient Temperature: 22.5°C, Liquid Temperature: 22.3°C

Communication System: LTE700-FDD12 707.5 MHz Duty Cycle: 1: 1

Probe: EX3DV4 – SN3617 ConvF(10.07,10.07,10.07)

**Area Scan (71x121x1):** Interpolated grid: dx=1.000 mm, dy=1.000 mm

Maximum value of SAR (interpolated) = 0.611 W/kg

**Zoom Scan (7x7x7)/Cube 0:** Measurement grid: dx=5mm, dy=5mm, dz=5mm

Reference Value = 21.95 V/m; Power Drift = -0.12 dB

Peak SAR (extrapolated) = 0.787 W/kg

**SAR(1 g) = 0.461 W/kg; SAR(10 g) = 0.346 W/kg**

Maximum value of SAR (measured) = 0.628 W/kg

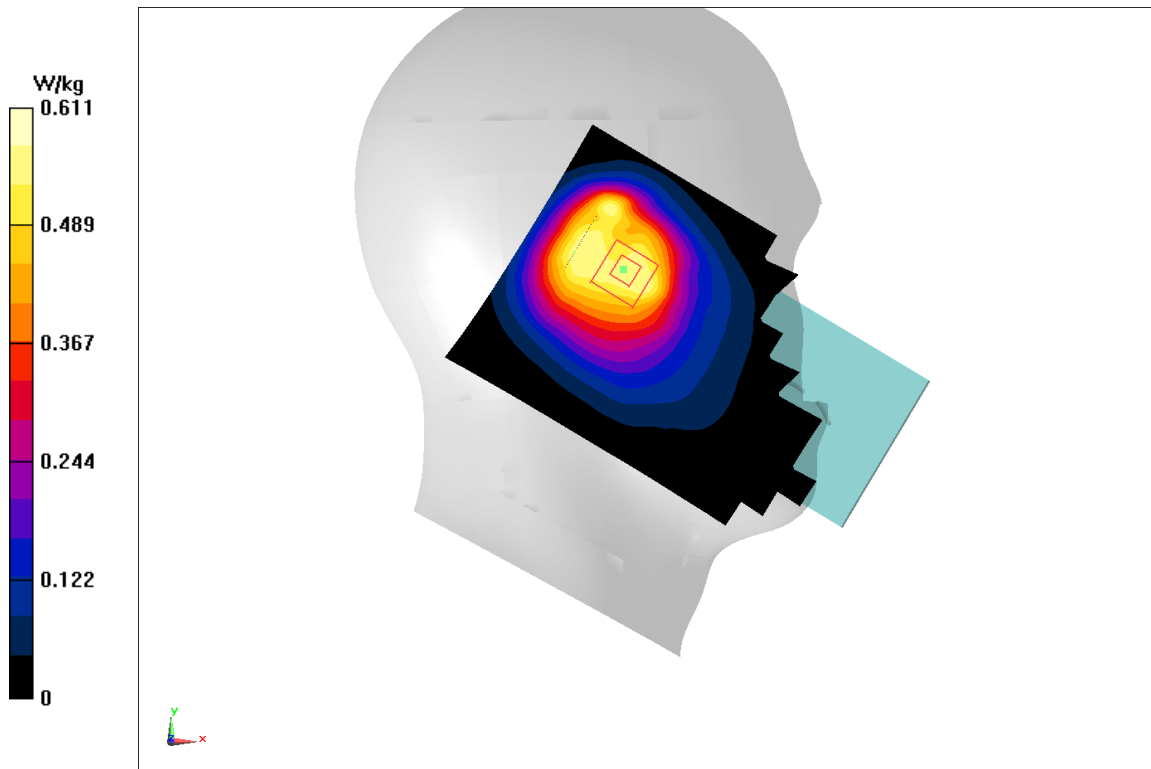

**Fig A.19**

**LTE700-FDD12\_CH23095 Right**

Date: 9/12/2020

Electronics: DAE4 Sn777

Medium: head 750 MHz

 Medium parameters used:  $f = 707.5$  MHz;  $\sigma = 0.85$  mho/m;  $\epsilon_r = 41.33$ ;  $\rho = 1000$  kg/m<sup>3</sup>

Ambient Temperature: 22.5°C, Liquid Temperature: 22.3°C

Communication System: LTE700-FDD12 707.5 MHz Duty Cycle: 1: 1

Probe: EX3DV4 – SN3617 ConvF(10.07,10.07,10.07)

**Area Scan (71x121x1):** Interpolated grid: dx=1.000 mm, dy=1.000 mm

Maximum value of SAR (interpolated) = 0.361 W/kg

**Zoom Scan (7x7x7)/Cube 0:** Measurement grid: dx=5mm, dy=5mm, dz=5mm

Reference Value = 20.53 V/m; Power Drift = 0 dB

Peak SAR (extrapolated) = 0.372 W/kg

**SAR(1 g) = 0.284 W/kg; SAR(10 g) = 0.207 W/kg**

Maximum value of SAR (measured) = 0.336 W/kg

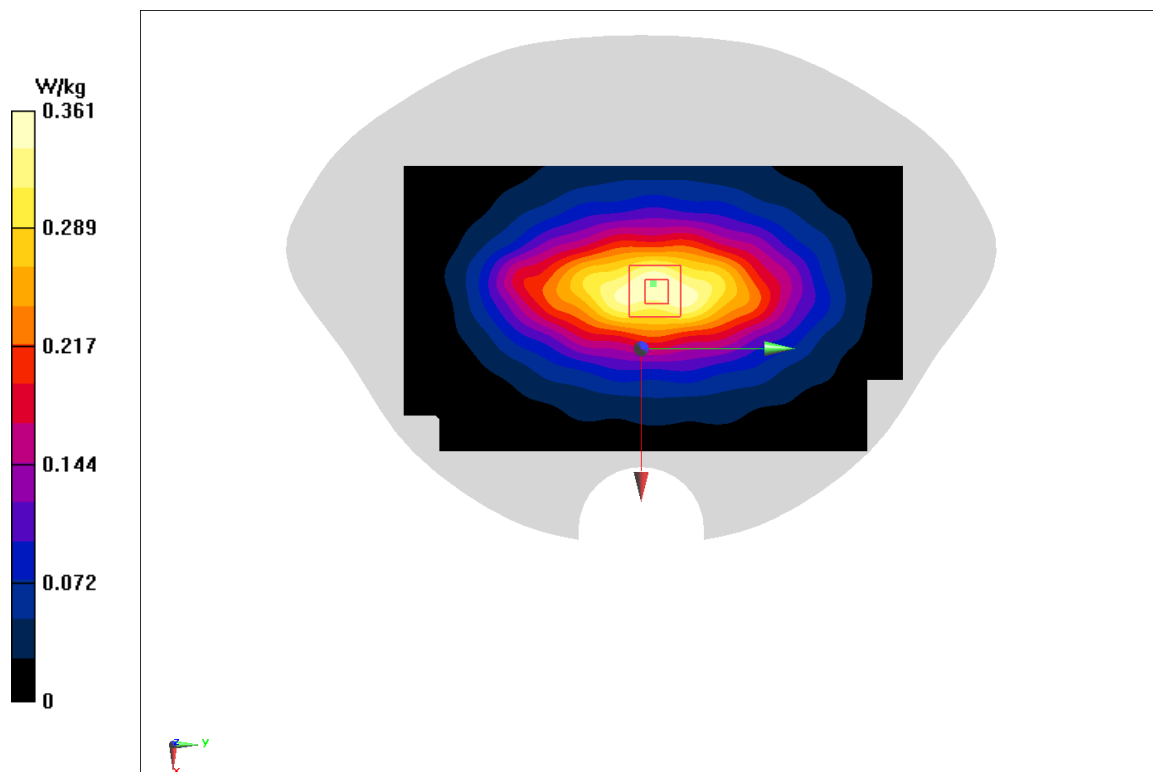
**Fig A.20**

**LTE750-FDD13\_CH23230 Left Cheek**

Date: 9/12/2020

Electronics: DAE4 Sn777

Medium: head 750 MHz

 Medium parameters used:  $f = 782 \text{ MHz}$ ;  $\sigma = 0.92 \text{ mho/m}$ ;  $\epsilon_r = 41.24$ ;  $\rho = 1000 \text{ kg/m}^3$ 

 Ambient Temperature:  $22.5^\circ\text{C}$ , Liquid Temperature:  $22.3^\circ\text{C}$ 

Communication System: LTE750-FDD13 782 MHz Duty Cycle: 1: 1

Probe: EX3DV4 – SN3617 ConvF(10.07,10.07,10.07)

**Area Scan (71x121x1):** Interpolated grid:  $dx=1.000 \text{ mm}$ ,  $dy=1.000 \text{ mm}$ 

 Maximum value of SAR (interpolated) =  $0.264 \text{ W/kg}$ 
**Zoom Scan (7x7x7)/Cube 0:** Measurement grid:  $dx=5\text{mm}$ ,  $dy=5\text{mm}$ ,  $dz=5\text{mm}$ 

 Reference Value =  $3.608 \text{ V/m}$ ; Power Drift =  $-0.06 \text{ dB}$ 

 Peak SAR (extrapolated) =  $0.275 \text{ W/kg}$ 
**SAR(1 g) =  $0.22 \text{ W/kg}$ ; SAR(10 g) =  $0.18 \text{ W/kg}$** 

 Maximum value of SAR (measured) =  $0.255 \text{ W/kg}$ 

Fig A.21

**LTE750-FDD13\_CH23230 Right**

Date: 9/12/2020

Electronics: DAE4 Sn777

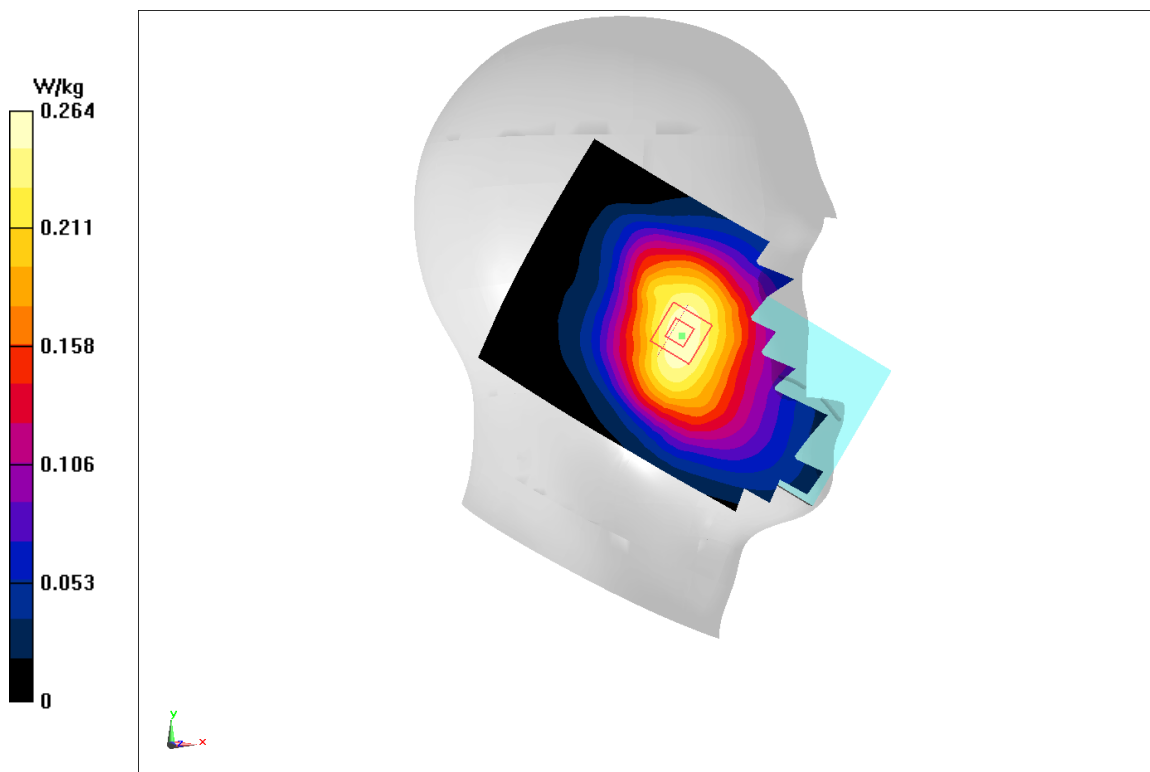
Medium: head 750 MHz

Medium parameters used:  $f = 782 \text{ MHz}$ ;  $\sigma = 0.92 \text{ mho/m}$ ;  $\epsilon_r = 41.24$ ;  $\rho = 1000 \text{ kg/m}^3$

Ambient Temperature:  $22.5^\circ\text{C}$ , Liquid Temperature:  $22.3^\circ\text{C}$

Communication System: LTE750-FDD13 782 MHz Duty Cycle: 1: 1

Probe: EX3DV4 – SN3617 ConvF(10.07,10.07,10.07)

**Area Scan (71x121x1):** Interpolated grid:  $dx=1.000 \text{ mm}$ ,  $dy=1.000 \text{ mm}$

Maximum value of SAR (interpolated) =  $0.74 \text{ W/kg}$

**Zoom Scan (7x7x7)/Cube 0:** Measurement grid:  $dx=5\text{mm}$ ,  $dy=5\text{mm}$ ,  $dz=5\text{mm}$

Reference Value =  $20.37 \text{ V/m}$ ; Power Drift =  $-0.07 \text{ dB}$

Peak SAR (extrapolated) =  $0.814 \text{ W/kg}$

**SAR(1 g) =  $0.452 \text{ W/kg}$ ; SAR(10 g) =  $0.233 \text{ W/kg}$**

Maximum value of SAR (measured) =  $0.689 \text{ W/kg}$

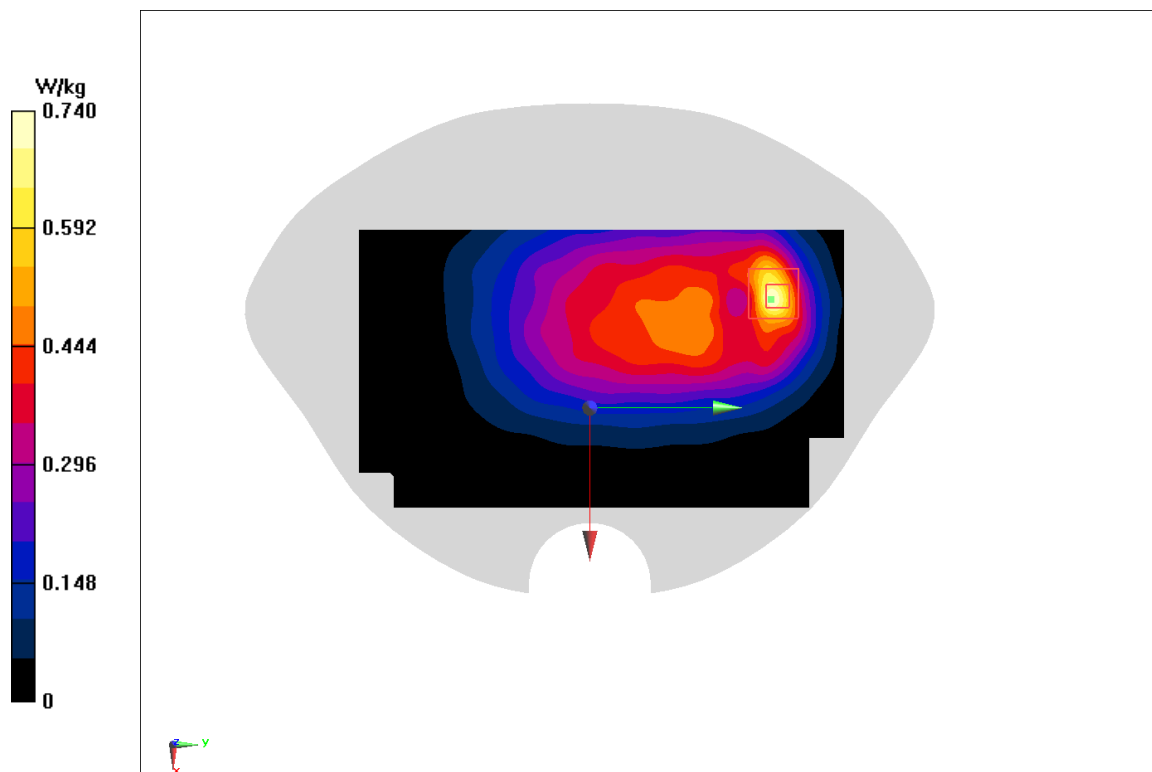

**Fig A.22**

**LTE1700-FDD66\_CH132072 Right Cheek**

Date: 9/14/2020

Electronics: DAE4 Sn777

Medium: head 1750 MHz

Medium parameters used:  $f = 782 \text{ MHz}$ ;  $\sigma = 0.438 \text{ mho/m}$ ;  $\epsilon_r = 40.85$ ;  $\rho = 1000 \text{ kg/m}^3$

Ambient Temperature:  $22.5^\circ\text{C}$ , Liquid Temperature:  $22.3^\circ\text{C}$

Communication System: LTE1700-FDD66 782 MHz Duty Cycle: 1: 1

Probe: EX3DV4 – SN3617 ConvF(8.41,8.41,8.41)

**Area Scan (71x121x1):** Interpolated grid:  $dx=1.000 \text{ mm}$ ,  $dy=1.000 \text{ mm}$

Maximum value of SAR (interpolated) =  $0.361 \text{ W/kg}$

**Zoom Scan (7x7x7)/Cube 0:** Measurement grid:  $dx=5\text{mm}$ ,  $dy=5\text{mm}$ ,  $dz=5\text{mm}$

Reference Value =  $6.164 \text{ V/m}$ ; Power Drift =  $0.06 \text{ dB}$

Peak SAR (extrapolated) =  $0.34 \text{ W/kg}$

**SAR(1 g) =  $0.227 \text{ W/kg}$ ; SAR(10 g) =  $0.145 \text{ W/kg}$**

Maximum value of SAR (measured) =  $0.299 \text{ W/kg}$

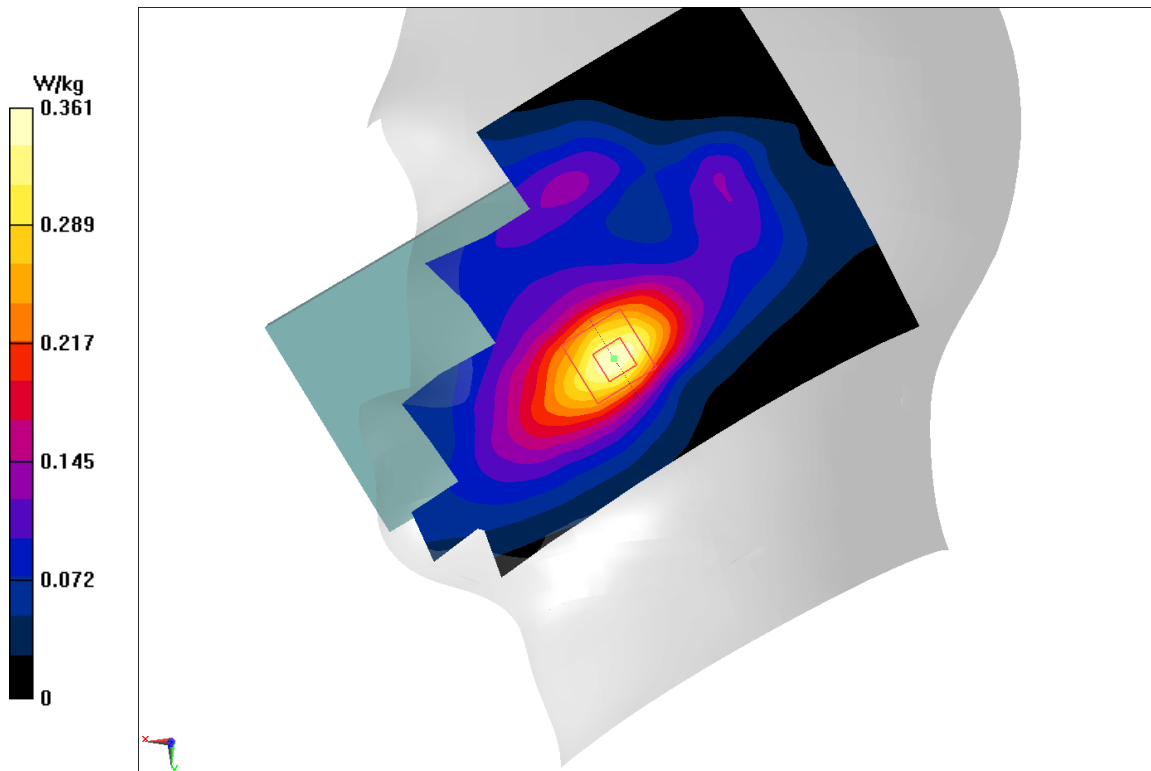

**Fig A.23**



**LTE1700-FDD66\_CH132322 Bottom**

Date: 9/14/2020

Electronics: DAE4 Sn777

Medium: head 1750 MHz

Medium parameters used:  $f = 782 \text{ MHz}$ ;  $\sigma = 0.438 \text{ mho/m}$ ;  $\epsilon_r = 40.85$ ;  $\rho = 1000 \text{ kg/m}^3$

Ambient Temperature:  $22.5^\circ\text{C}$ , Liquid Temperature:  $22.3^\circ\text{C}$

Communication System: LTE1700-FDD66 782 MHz Duty Cycle: 1: 1

Probe: EX3DV4 – SN3617 ConvF(8.41,8.41,8.41)

**Area Scan (71x121x1):** Interpolated grid:  $dx=1.000 \text{ mm}$ ,  $dy=1.000 \text{ mm}$

Maximum value of SAR (interpolated) =  $1.64 \text{ W/kg}$

**Zoom Scan (7x7x7)/Cube 0:** Measurement grid:  $dx=5\text{mm}$ ,  $dy=5\text{mm}$ ,  $dz=5\text{mm}$

Reference Value =  $18.83 \text{ V/m}$ ; Power Drift =  $-0.03 \text{ dB}$

Peak SAR (extrapolated) =  $2 \text{ W/kg}$

**SAR(1 g) =  $1.09 \text{ W/kg}$ ; SAR(10 g) =  $0.556 \text{ W/kg}$**

Maximum value of SAR (measured) =  $1.68 \text{ W/kg}$

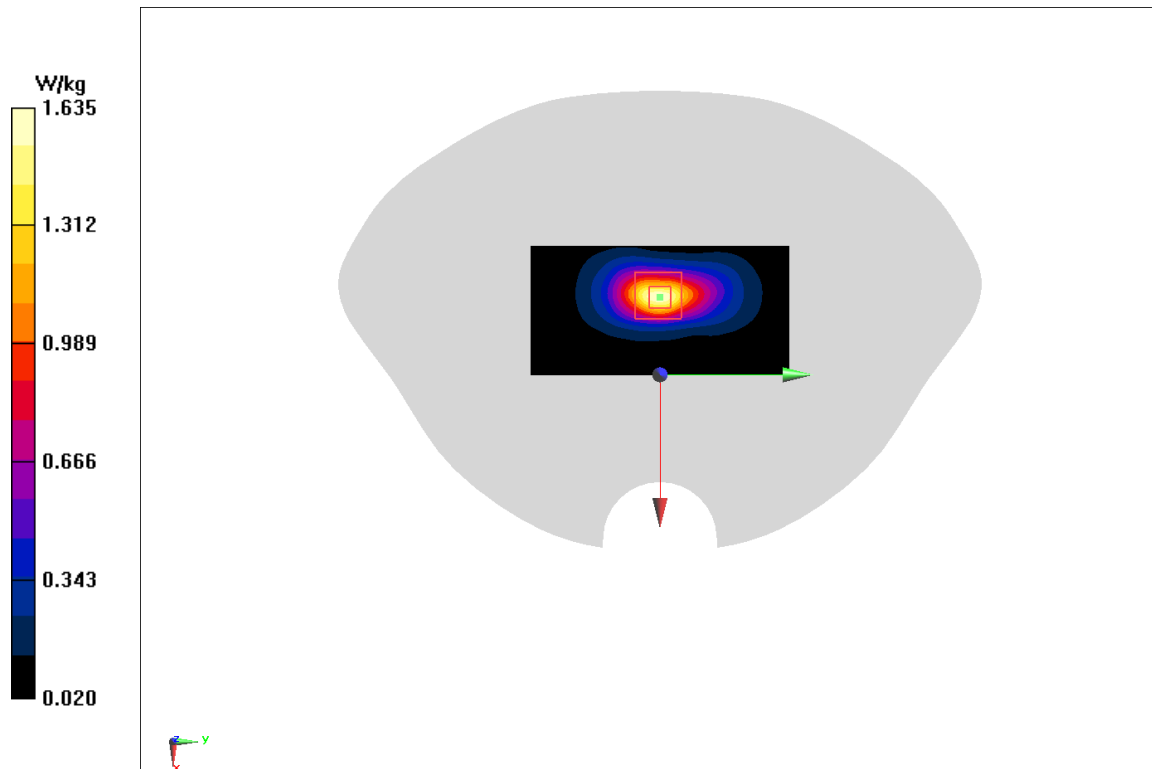

**Fig A.24**

**LTE1700-FDD66\_CH132322 Front**

Date: 9/14/2020

Electronics: DAE4 Sn777

Medium: head 1750 MHz

Medium parameters used:  $f = 782 \text{ MHz}$ ;  $\sigma = 0.438 \text{ mho/m}$ ;  $\epsilon_r = 40.85$ ;  $\rho = 1000 \text{ kg/m}^3$

Ambient Temperature:  $22.5^\circ\text{C}$ , Liquid Temperature:  $22.3^\circ\text{C}$

Communication System: LTE1700-FDD66 782 MHz Duty Cycle: 1: 1

Probe: EX3DV4 – SN3617 ConvF(8.41,8.41,8.41)

**Area Scan (71x121x1):** Interpolated grid:  $dx=1.000 \text{ mm}$ ,  $dy=1.000 \text{ mm}$

Maximum value of SAR (interpolated) =  $0.975 \text{ W/kg}$

**Zoom Scan (7x7x7)/Cube 0:** Measurement grid:  $dx=5\text{mm}$ ,  $dy=5\text{mm}$ ,  $dz=5\text{mm}$

Reference Value =  $11.33 \text{ V/m}$ ; Power Drift =  $0.04 \text{ dB}$

Peak SAR (extrapolated) =  $1.16 \text{ W/kg}$

**SAR(1 g) =  $0.754 \text{ W/kg}$ ; SAR(10 g) =  $0.452 \text{ W/kg}$**

Maximum value of SAR (measured) =  $1.02 \text{ W/kg}$

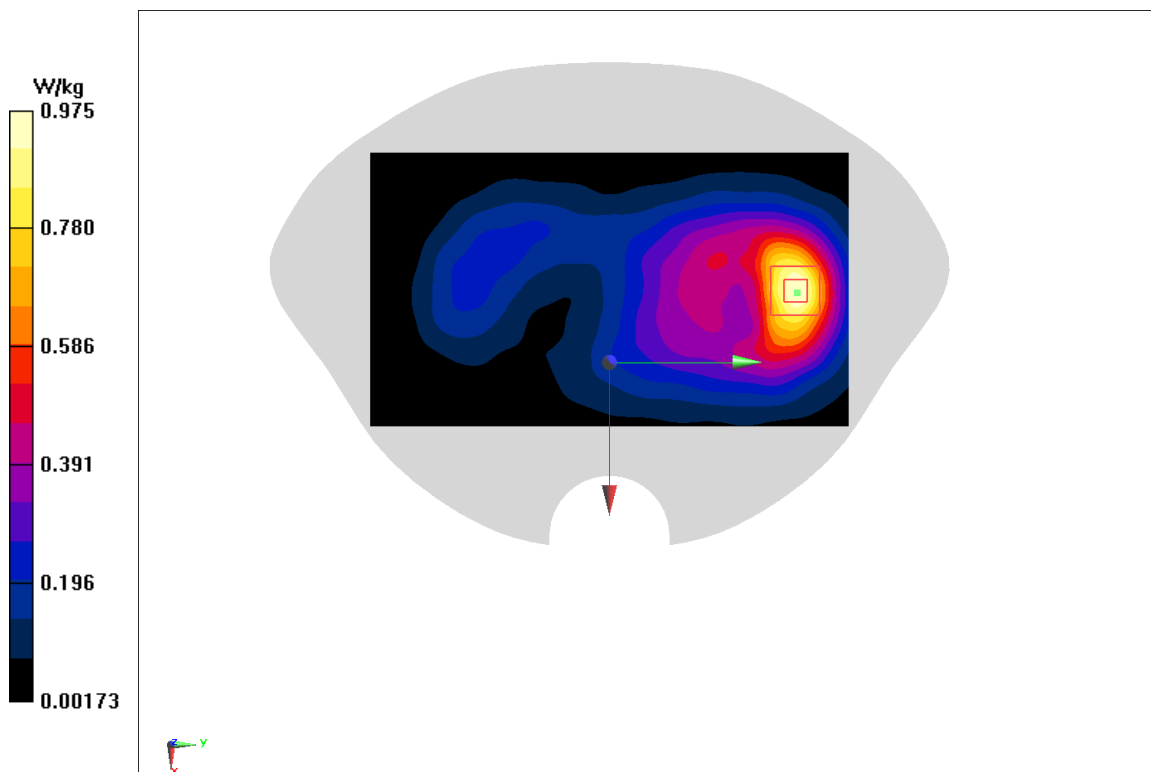

**Fig A.25**

**WLAN2450\_CH1 Right Cheek**

Date: 9/16/2020

Electronics: DAE4 Sn777

Medium: head 2450 MHz

Medium parameters used:  $f = 2412$ ;  $\sigma = 1.8$  mho/m;  $\epsilon_r = 39.24$ ;  $\rho = 1000$  kg/m<sup>3</sup>

Ambient Temperature: 22.5°C, Liquid Temperature: 22.3°C

Communication System: WLAN2450 2412 Duty Cycle: 1: 1

Probe: EX3DV4 – SN3617 ConvF(7.65,7.65,7.65)

**Area Scan (71x121x1):** Interpolated grid: dx=1.000 mm, dy=1.000 mm

Maximum value of SAR (interpolated) = 0.443 W/kg

**Zoom Scan (7x7x7)/Cube 0:** Measurement grid: dx=5mm, dy=5mm, dz=5mm

Reference Value = 8.583 V/m; Power Drift = 0.03 dB

Peak SAR (extrapolated) = 0.483 W/kg

**SAR(1 g) = 0.29 W/kg; SAR(10 g) = 0.154 W/kg**

Maximum value of SAR (measured) = 0.413 W/kg

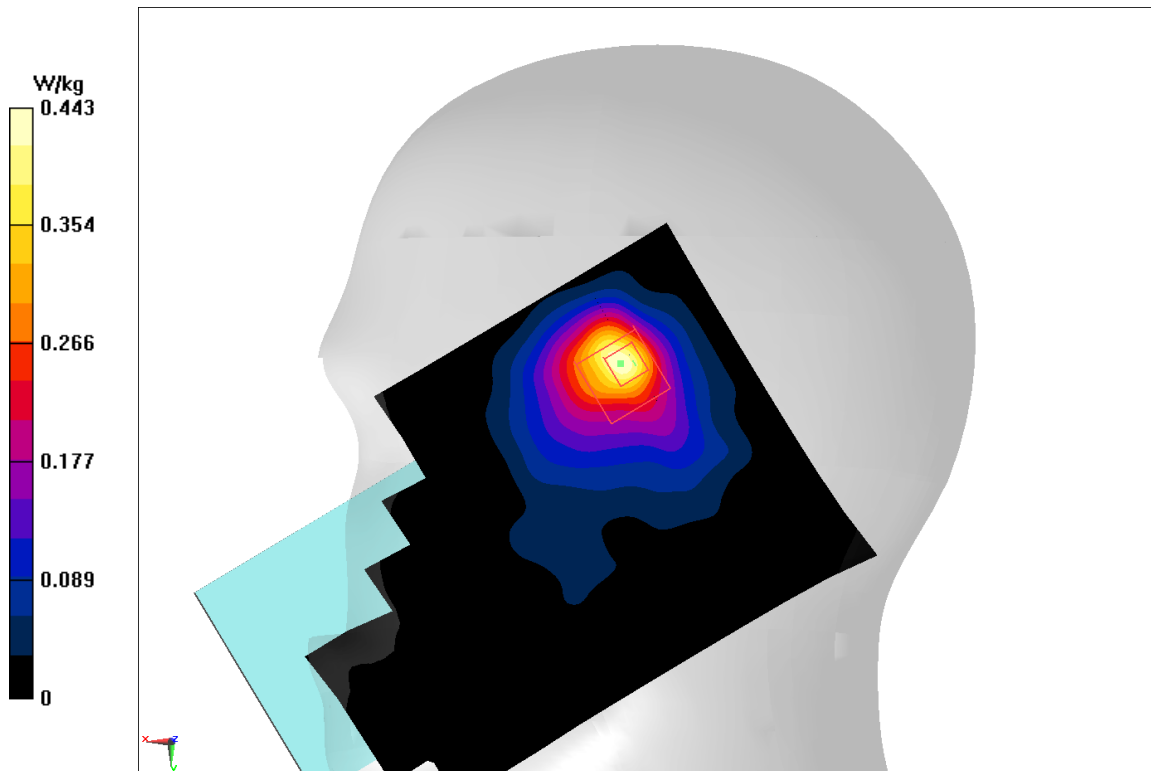

Fig A.26

**WLAN2450\_CH1 Rear**

Date: 9/16/2020

Electronics: DAE4 Sn777

Medium: head 2450 MHz

Medium parameters used:  $f = 2412$ ;  $\sigma = 1.8$  mho/m;  $\epsilon_r = 39.24$ ;  $\rho = 1000$  kg/m<sup>3</sup>

Ambient Temperature: 22.5°C, Liquid Temperature: 22.3°C

Communication System: WLAN2450 2412 Duty Cycle: 1: 1

Probe: EX3DV4 – SN3617 ConvF(7.65,7.65,7.65)

**Area Scan (71x121x1):** Interpolated grid: dx=1.000 mm, dy=1.000 mm

Maximum value of SAR (interpolated) = 0.249 W/kg

**Zoom Scan (7x7x7)/Cube 0:** Measurement grid: dx=5mm, dy=5mm, dz=5mm

Reference Value = 3.781 V/m; Power Drift = 0.05 dB

Peak SAR (extrapolated) = 0.325 W/kg

**SAR(1 g) = 0.16 W/kg; SAR(10 g) = 0.077 W/kg**

Maximum value of SAR (measured) = 0.245 W/kg

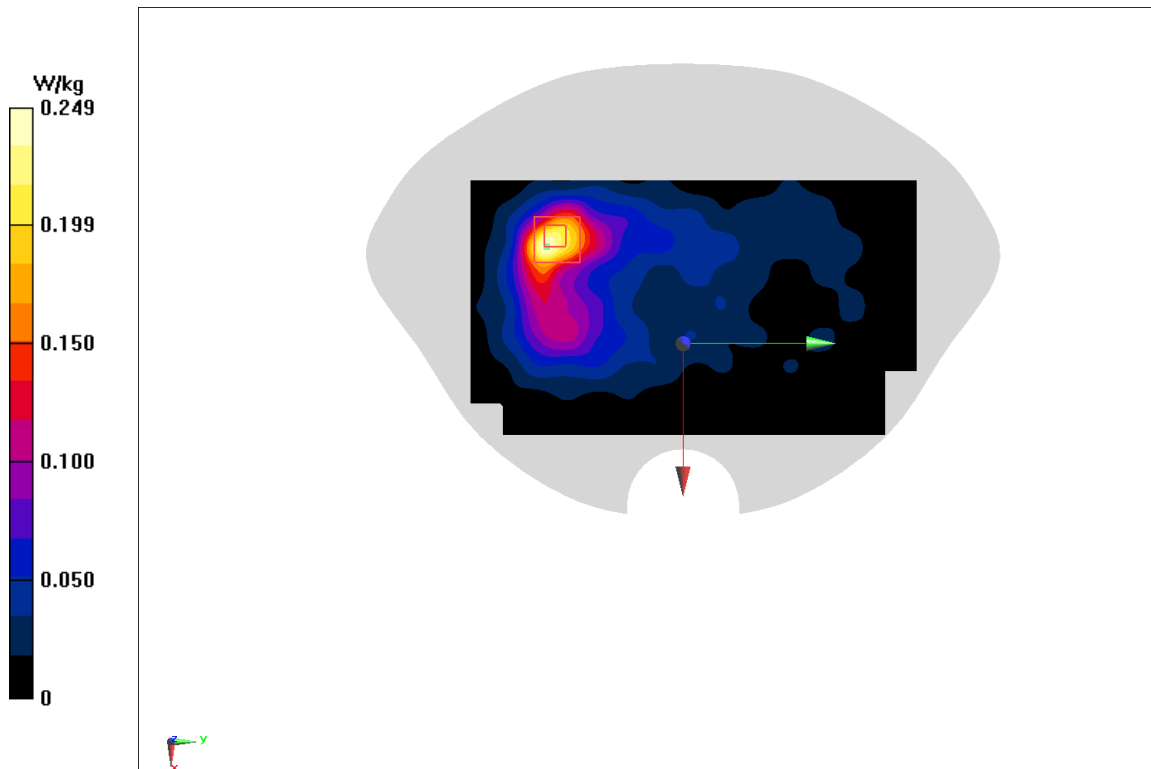

**Fig A.27**

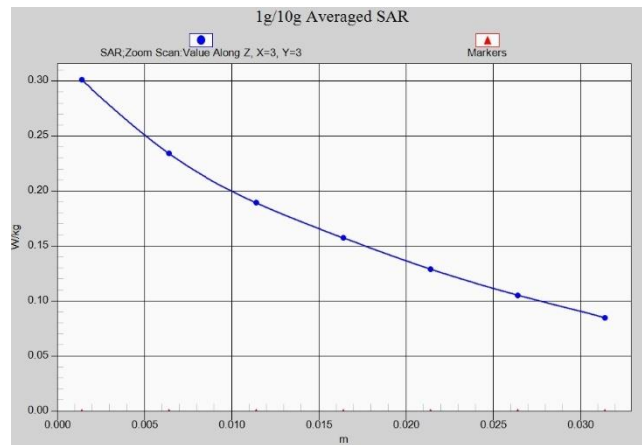

**Fig. 1-1 Z-Scan at power reference point (850 MHz)**

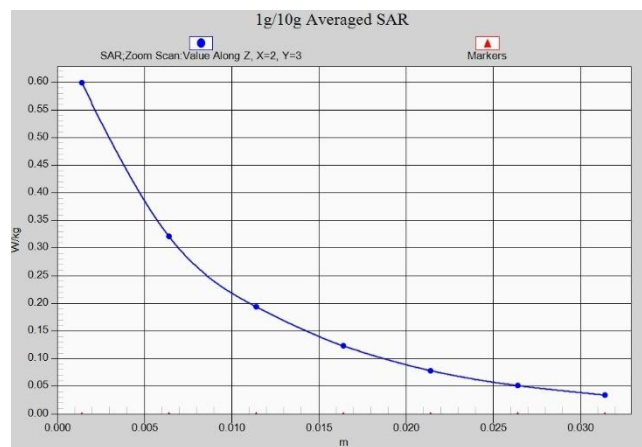

**Fig. 1-2 Z-Scan at power reference point (850 MHz)**

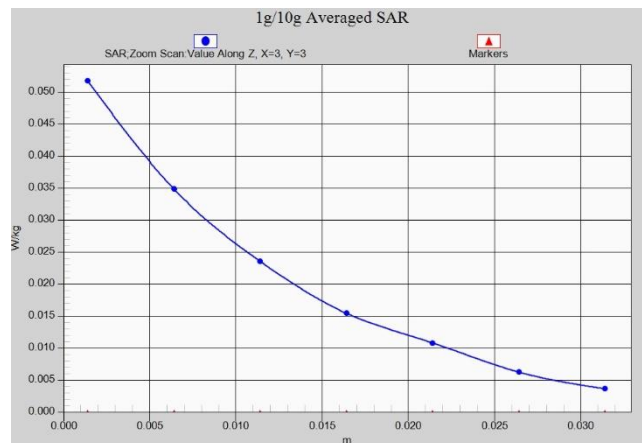

**Fig. 1-3 Z-Scan at power reference point (1900 MHz)**

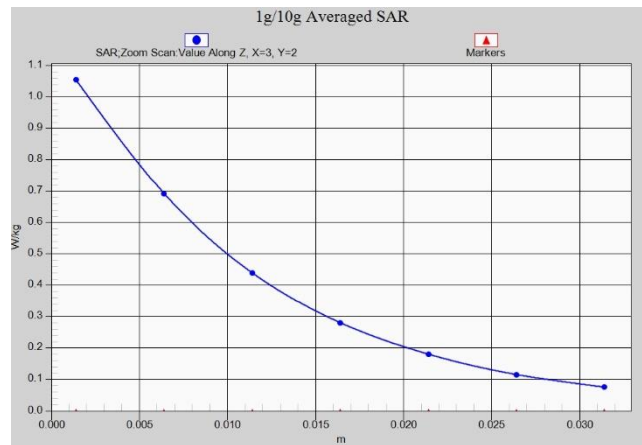

**Fig. 1-4 Z-Scan at power reference point (1900 MHz)**

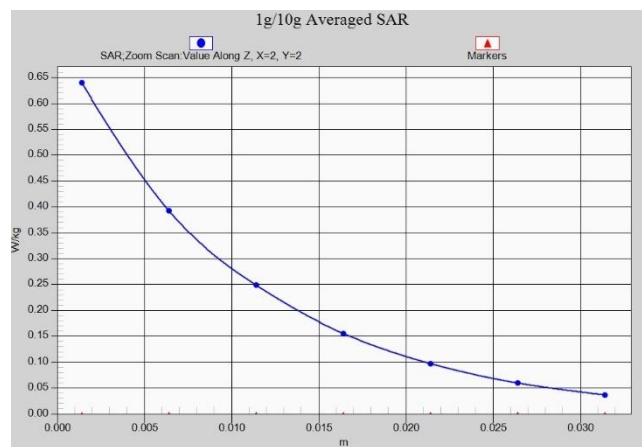

**Fig. 1-5 Z-Scan at power reference point (1900 MHz)**

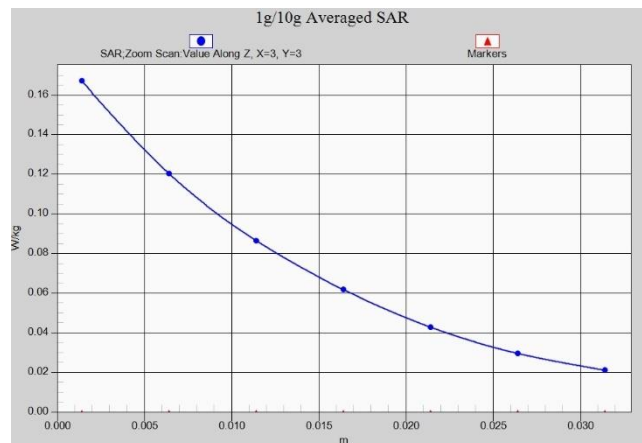

**Fig. 1-6 Z-Scan at power reference point (WCDMA1900)**

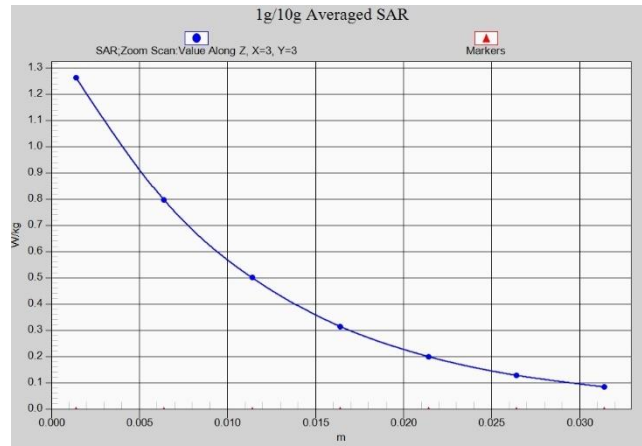

**Fig. 1-7 Z-Scan at power reference point (WCDMA1900)**

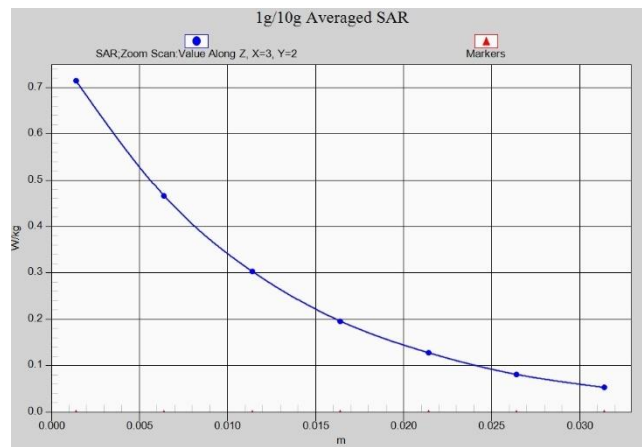

**Fig. 1-8 Z-Scan at power reference point (WCDMA1900)**

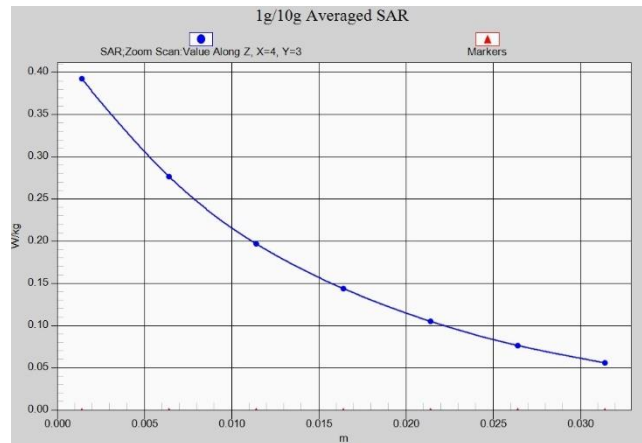

**Fig. 1-9 Z-Scan at power reference point (WCDMA1700)**

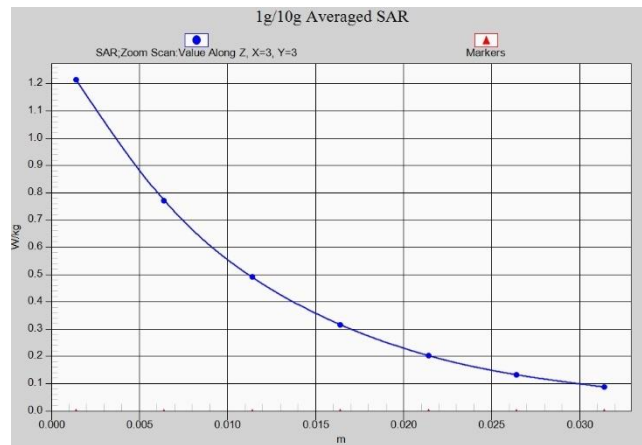

**Fig. 1-10 Z-Scan at power reference point (WCDMA1700)**

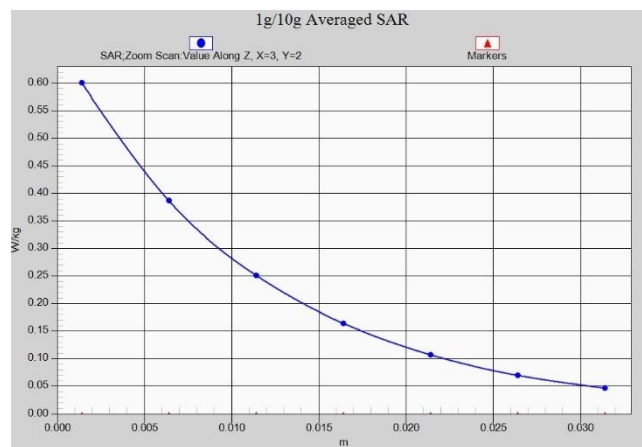

**Fig. 1-11 Z-Scan at power reference point (WCDMA1700)**

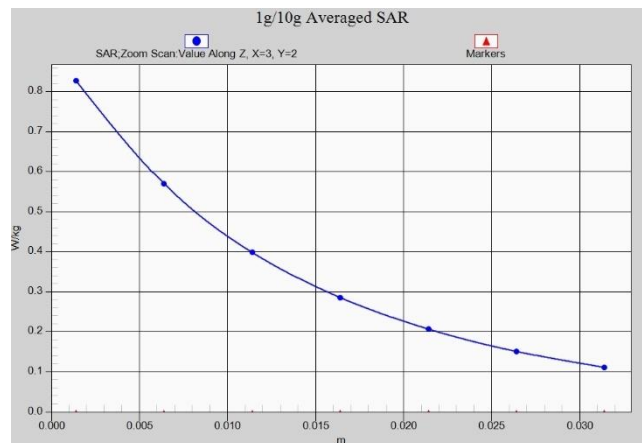
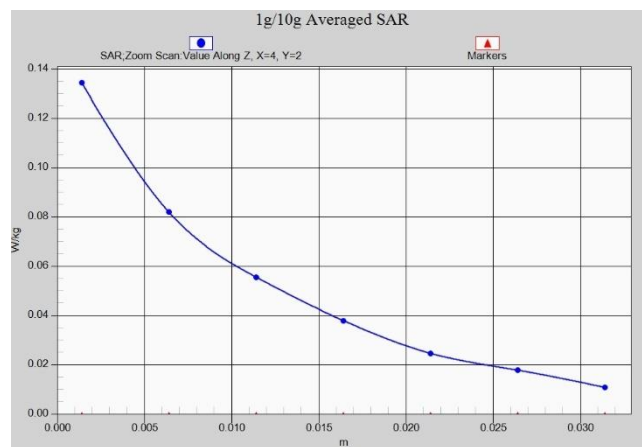

**Fig. 1-12 Z-Scan at power reference point (WCDMA850)**

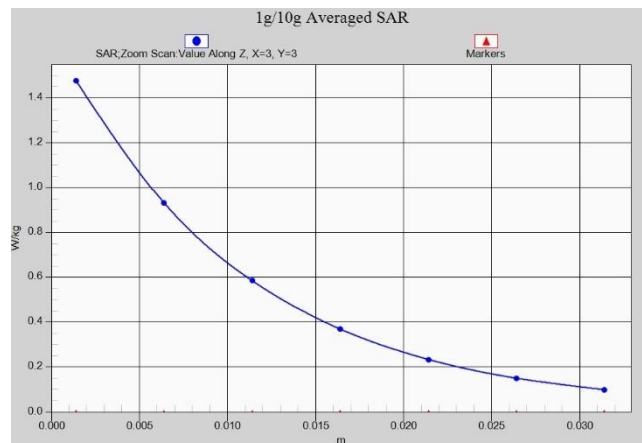



**Fig. 1-13 Z-Scan at power reference point (WCDMA850)**



**Fig. 1-14 Z-Scan at power reference point (LTE Band2)**



**Fig. 1-15 Z-Scan at power reference point (LTE Band2)**

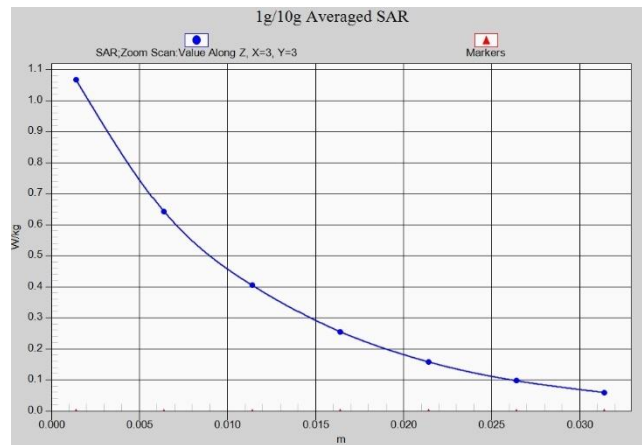

Fig. 1-16 Z-Scan at power reference point (LTE Band2)

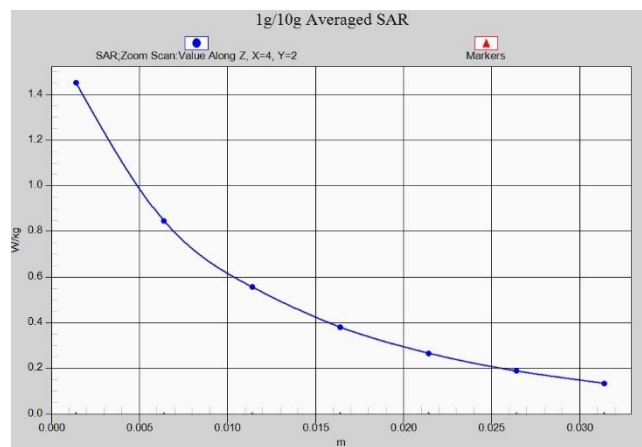

Fig. 1-18 Z-Scan at power reference point (LTE Band5)

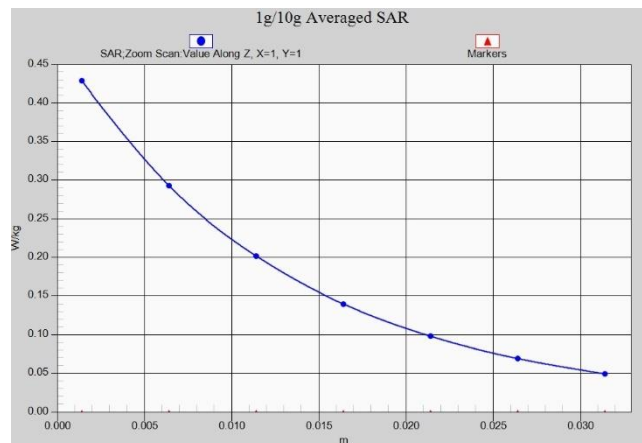

Fig. 1-18 Z-Scan at power reference point (LTE Band5)

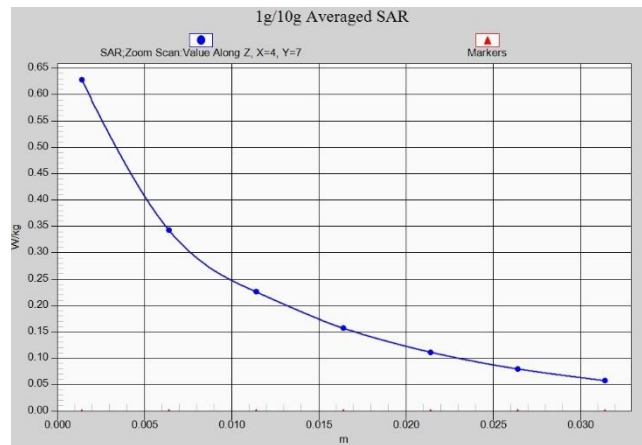

Fig. 1-19 Z-Scan at power reference point (LTE Band12)

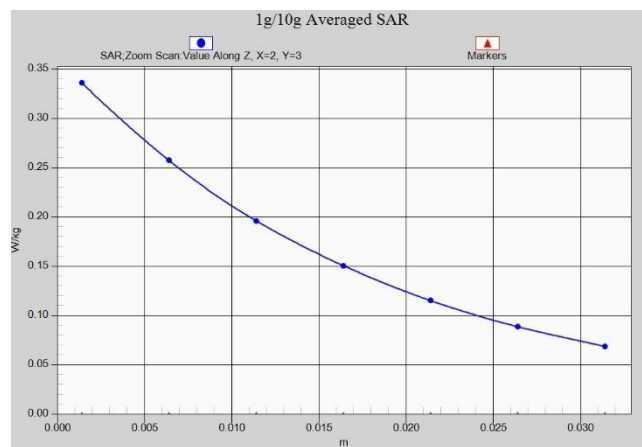

Fig. 1-20 Z-Scan at power reference point (LTE Band12)

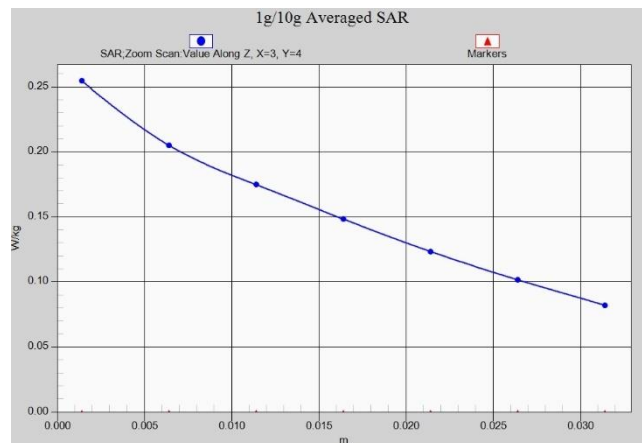

Fig. 1-21 Z-Scan at power reference point (LTE Band13)

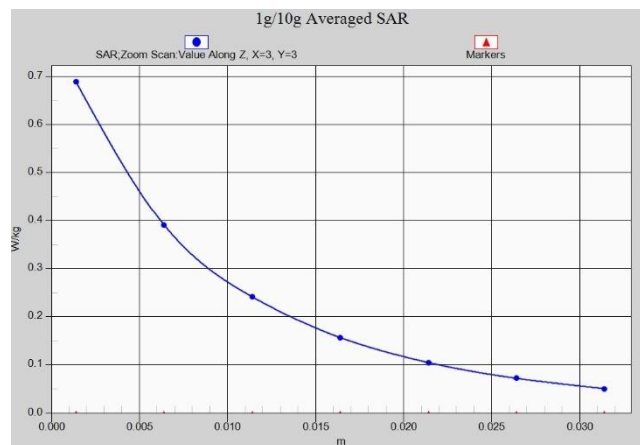

Fig. 1-22 Z-Scan at power reference point (LTE Band13)

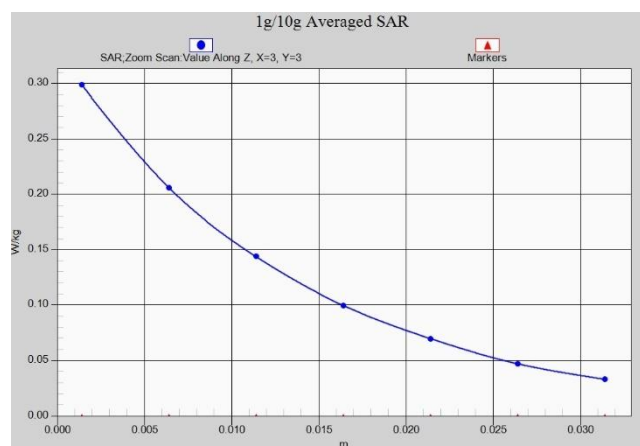

Fig. 1-23 Z-Scan at power reference point (LTE Band66)

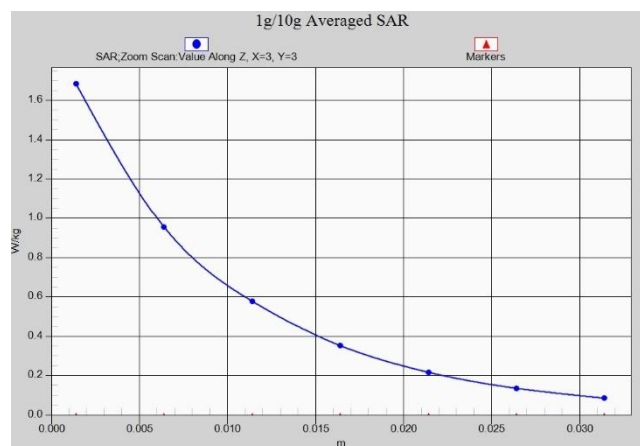
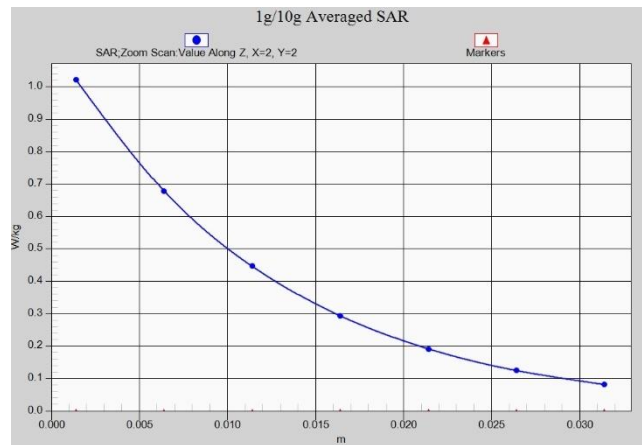
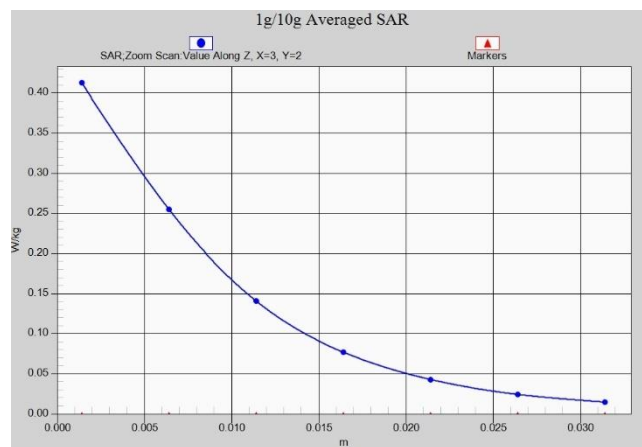

Fig. 1-24 Z-Scan at power reference point (LTE Band66)



**Fig. 1-25 Z-Scan at power reference point (LTE Band66)**



**Fig. 1-26 Z-Scan at power reference point (wifi2450)**

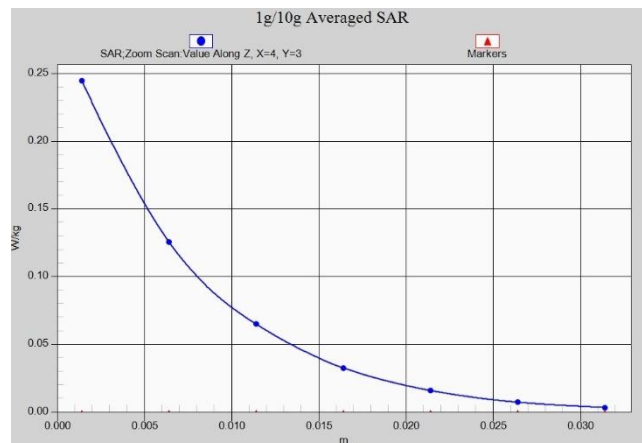

**Fig. 1-27 Z-Scan at power reference point (wifi2450)**

## ANNEX B System Verification Results

### 750 MHz

Date: 9/12/2020

Electronics: DAE4 Sn777

Medium: Head 750 MHz

Medium parameters used:  $f = 750 \text{ MHz}$ ;  $\sigma = 0.89 \text{ mho/m}$ ;  $\epsilon_r = 41.28$ ;  $\rho = 1000 \text{ kg/m}^3$

Ambient Temperature:  $22.5^\circ\text{C}$  Liquid Temperature:  $22.3^\circ\text{C}$

Communication System: CW Frequency: 750 MHz Duty Cycle: 1:1

Probe: EX3DV4 – SN3617 ConvF(10.07,10.07,10.07)

**System Validation /Area Scan (81x191x1):** Interpolated grid:  $dx=1.000 \text{ mm}$ ,  $dy=1.000 \text{ mm}$

Reference Value =  $59.36 \text{ V/m}$ ; Power Drift = 0.02

**Fast SAR: SAR(1 g) =  $2.08 \text{ W/kg}$ ; SAR(10 g) =  $1.37 \text{ W/kg}$**

Maximum value of SAR (interpolated) =  $2.78 \text{ W/kg}$

**System Validation /Zoom Scan (7x7x7)/Cube 0:** Measurement grid:  $dx=5\text{mm}$ ,  $dy=5\text{mm}$ ,  $dz=5\text{mm}$

Reference Value =  $59.36 \text{ V/m}$ ; Power Drift = 0.02 dB

Peak SAR (extrapolated) =  $3.2 \text{ W/kg}$

**SAR(1 g) =  $2.08 \text{ W/kg}$ ; SAR(10 g) =  $1.39 \text{ W/kg}$**

Maximum value of SAR (measured) =  $2.91 \text{ W/kg}$

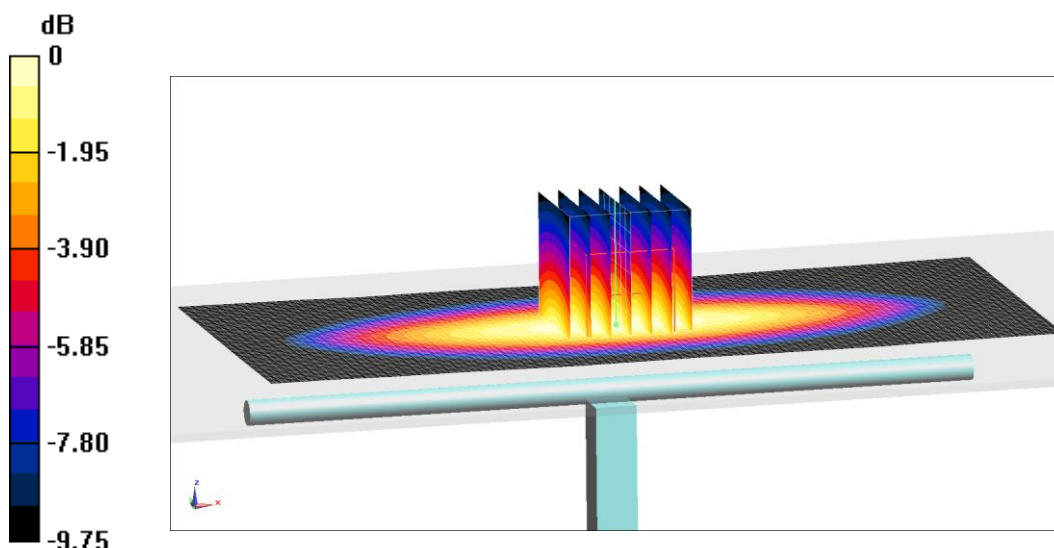

0 dB =  $2.91 \text{ W/kg}$  =  $4.64 \text{ dB W/kg}$

**Fig.B.1 validation 750 MHz 250mW**