

DASY5 Validation Report for Head TSL

Date: 16.07.2019

Test Laboratory: SPEAG, Zurich, Switzerland

DUT: Dipole 2450 MHz; Type: D2450V2; Serial: D2450V2 - SN:853

Communication System: UID 0 - CW; Frequency: 2450 MHz

Medium parameters used: $f = 2450$ MHz; $\sigma = 1.85$ S/m; $\epsilon_r = 37.6$; $\rho = 1000$ kg/m³

Phantom section: Flat Section

Measurement Standard: DASY5 (IEEE/IEC/ANSI C63.19-2011)

DASY52 Configuration:

- Probe: EX3DV4 - SN7349; ConvF(7.9, 7.9, 7.9) @ 2450 MHz; Calibrated: 29.05.2019
- Sensor-Surface: 1.4mm (Mechanical Surface Detection)
- Electronics: DAE4 Sn601; Calibrated: 30.04.2019
- Phantom: Flat Phantom 5.0 (front); Type: QD 000 P50 AA; Serial: 1001
- DASY52 52.10.2(1504); SEMCAD X 14.6.12(7470)

Dipole Calibration for Head Tissue/Pin=250 mW, d=10mm/Zoom Scan (7x7x7)/Cube 0:

Measurement grid: dx=5mm, dy=5mm, dz=5mm

Reference Value = 115.6 V/m; Power Drift = -0.01 dB

Peak SAR (extrapolated) = 25.7 W/kg

SAR(1 g) = 13.2 W/kg; SAR(10 g) = 6.13 W/kg

Maximum value of SAR (measured) = 21.5 W/kg

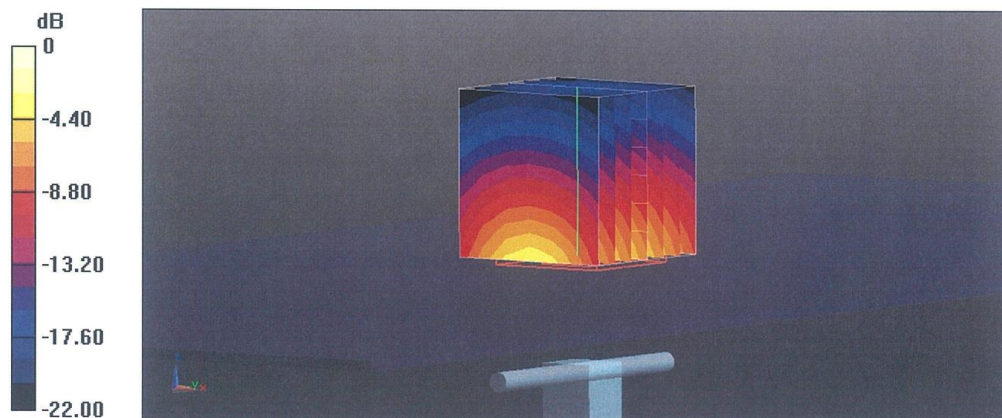

0 dB = 21.5 W/kg = 13.32 dBW/kg

Impedance Measurement Plot for Head TSL

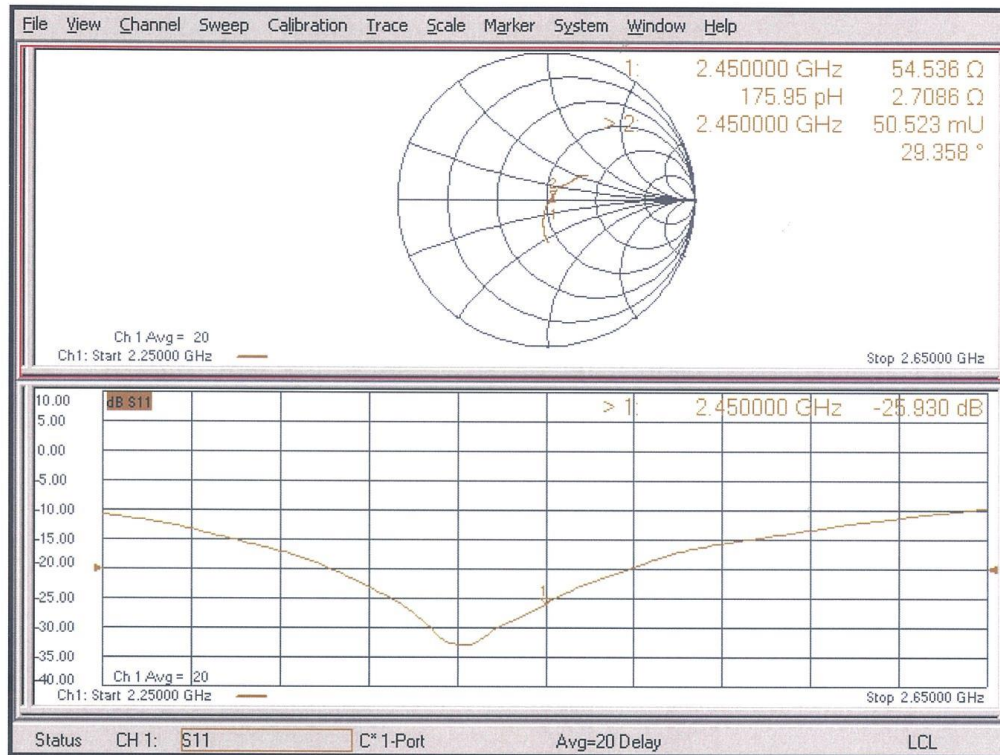

DASY5 Validation Report for Body TSL

Date: 17.07.2019

Test Laboratory: SPEAG, Zurich, Switzerland

DUT: Dipole 2450 MHz; Type: D2450V2; Serial: D2450V2 - SN:853

Communication System: UID 0 - CW; Frequency: 2450 MHz

Medium parameters used: $f = 2450$ MHz; $\sigma = 2.02$ S/m; $\epsilon_r = 50.8$; $\rho = 1000$ kg/m³

Phantom section: Flat Section

Measurement Standard: DASY5 (IEEE/IEC/ANSI C63.19-2011)

DASY52 Configuration:

- Probe: EX3DV4 - SN7349; ConvF(7.94, 7.94, 7.94) @ 2450 MHz; Calibrated: 29.05.2019
- Sensor-Surface: 1.4mm (Mechanical Surface Detection)
- Electronics: DAE4 Sn601; Calibrated: 30.04.2019
- Phantom: Flat Phantom 5.0 (back); Type: QD 000 P50 AA; Serial: 1002
- DASY52 52.10.2(1504); SEMCAD X 14.6.12(7470)

Dipole Calibration for Body Tissue/Pin=250 mW, d=10mm/Zoom Scan (7x7x7)/Cube 0:

Measurement grid: dx=5mm, dy=5mm, dz=5mm

Reference Value = 110.2 V/m; Power Drift = -0.08 dB

Peak SAR (extrapolated) = 26.3 W/kg

SAR(1 g) = 13.4 W/kg; SAR(10 g) = 6.23 W/kg

Maximum value of SAR (measured) = 21.8 W/kg

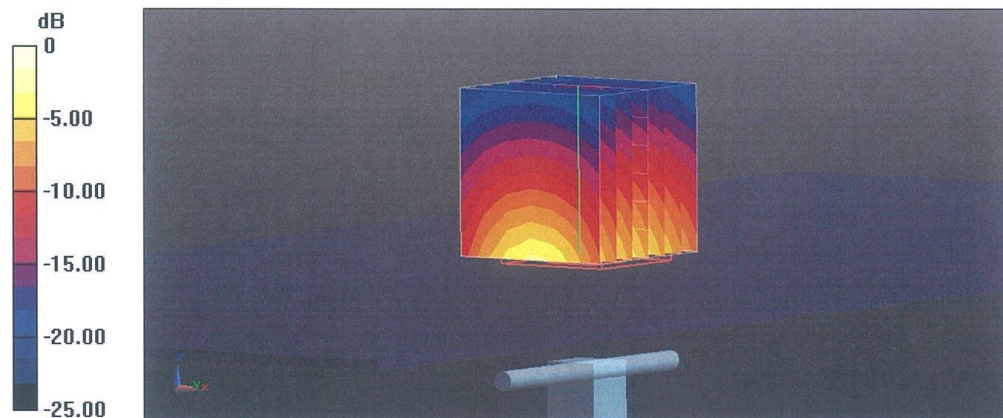

0 dB = 21.8 W/kg = 13.38 dBW/kg

Impedance Measurement Plot for Body TSL

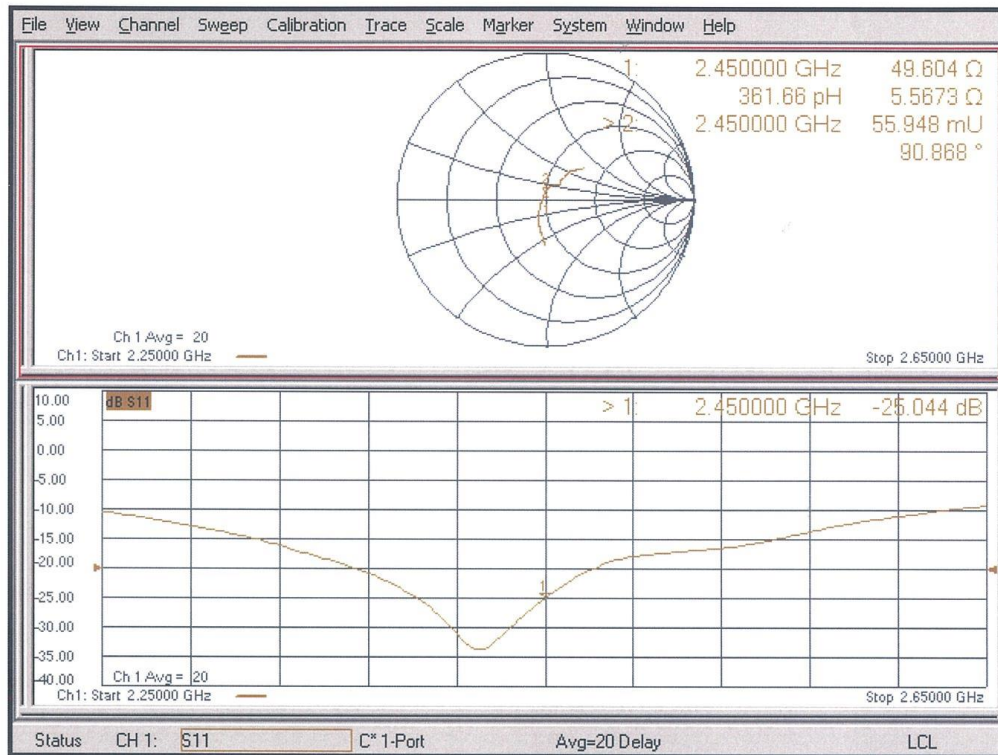



No.I19Z62100-SEM02

2600 MHz Dipole Calibration Certificate

**Calibration Laboratory of
Schmid & Partner
Engineering AG**
Zeughausstrasse 43, 8004 Zurich, Switzerland



S Schweizerischer Kalibrierdienst
S Service suisse d'étalonnage
C Servizio svizzero di taratura
S Swiss Calibration Service

Accredited by the Swiss Accreditation Service (SAS)
The Swiss Accreditation Service is one of the signatories to the EA
Multilateral Agreement for the recognition of calibration certificates

Accreditation No.: **SCS 0108**

Client **CTTL (Auden)**

Certificate No: **D2600V2-1012_Jul19**

CALIBRATION CERTIFICATE

Object: **D2600V2 - SN:1012**

Calibration procedure(s): **QA CAL-05.v11
Calibration Procedure for SAR Validation Sources between 0.7-3 GHz**

Calibration date: **July 17, 2019**

This calibration certificate documents the traceability to national standards, which realize the physical units of measurements (SI). The measurements and the uncertainties with confidence probability are given on the following pages and are part of the certificate.

All calibrations have been conducted in the closed laboratory facility: environment temperature (22 ± 3)°C and humidity < 70%.

Calibration Equipment used (M&TE critical for calibration)

Primary Standards	ID #	Cal Date (Certificate No.)	Scheduled Calibration
Power meter NRP	SN: 104778	03-Apr-19 (No. 217-02892/02893)	Apr-20
Power sensor NRP-Z91	SN: 103244	03-Apr-19 (No. 217-02892)	Apr-20
Power sensor NRP-Z91	SN: 103245	03-Apr-19 (No. 217-02893)	Apr-20
Reference 20 dB Attenuator	SN: 5058 (20k)	04-Apr-19 (No. 217-02894)	Apr-20
Type-N mismatch combination	SN: 5047.2 / 06327	04-Apr-19 (No. 217-02895)	Apr-20
Reference Probe EX3DV4	SN: 7349	29-May-19 (No. EX3-7349_May19)	May-20
DAE4	SN: 601	30-Apr-19 (No. DAE4-601_Apr19)	Apr-20
Secondary Standards	ID #	Check Date (in house)	Scheduled Check
Power meter E4419B	SN: GB39512475	30-Oct-14 (in house check Feb-19)	In house check: Oct-20
Power sensor HP 8481A	SN: US37292783	07-Oct-15 (in house check Oct-18)	In house check: Oct-20
Power sensor HP 8481A	SN: MY41092317	07-Oct-15 (in house check Oct-18)	In house check: Oct-20
RF generator R&S SMT-06	SN: 100972	15-Jun-15 (in house check Oct-18)	In house check: Oct-20
Network Analyzer Agilent E8358A	SN: US41080477	31-Mar-14 (in house check Oct-18)	In house check: Oct-19

Calibrated by: **Michael Weber** (Name), **Laboratory Technician** (Function), *[Signature]* (Signature)

Approved by: **Katja Pokovic** (Name), **Technical Manager** (Function), *[Signature]* (Signature)

Issued: July 17, 2019

This calibration certificate shall not be reproduced except in full without written approval of the laboratory.

**Calibration Laboratory of
Schmid & Partner
Engineering AG**
Zeughausstrasse 43, 8004 Zurich, Switzerland



S Schweizerischer Kalibrierdienst
S Service suisse d'étalonnage
C Servizio svizzero di taratura
S Swiss Calibration Service

Accredited by the Swiss Accreditation Service (SAS)

The Swiss Accreditation Service is one of the signatories to the EA
Multilateral Agreement for the recognition of calibration certificates

Accreditation No.: **SCS 0108**

Glossary:

TSL	tissue simulating liquid
ConvF	sensitivity in TSL / NORM x,y,z
N/A	not applicable or not measured

Calibration is Performed According to the Following Standards:

- IEEE Std 1528-2013, "IEEE Recommended Practice for Determining the Peak Spatial-Averaged Specific Absorption Rate (SAR) in the Human Head from Wireless Communications Devices: Measurement Techniques", June 2013
- IEC 62209-1, "Measurement procedure for the assessment of Specific Absorption Rate (SAR) from hand-held and body-mounted devices used next to the ear (frequency range of 300 MHz to 6 GHz)", July 2016
- IEC 62209-2, "Procedure to determine the Specific Absorption Rate (SAR) for wireless communication devices used in close proximity to the human body (frequency range of 30 MHz to 6 GHz)", March 2010
- KDB 865664, "SAR Measurement Requirements for 100 MHz to 6 GHz"

Additional Documentation:

- DASY4/5 System Handbook

Methods Applied and Interpretation of Parameters:

- Measurement Conditions:** Further details are available from the Validation Report at the end of the certificate. All figures stated in the certificate are valid at the frequency indicated.
- Antenna Parameters with TSL:** The dipole is mounted with the spacer to position its feed point exactly below the center marking of the flat phantom section, with the arms oriented parallel to the body axis.
- Feed Point Impedance and Return Loss:** These parameters are measured with the dipole positioned under the liquid filled phantom. The impedance stated is transformed from the measurement at the SMA connector to the feed point. The Return Loss ensures low reflected power. No uncertainty required.
- Electrical Delay:** One-way delay between the SMA connector and the antenna feed point. No uncertainty required.
- SAR measured:** SAR measured at the stated antenna input power.
- SAR normalized:** SAR as measured, normalized to an input power of 1 W at the antenna connector.
- SAR for nominal TSL parameters:** The measured TSL parameters are used to calculate the nominal SAR result.

The reported uncertainty of measurement is stated as the standard uncertainty of measurement multiplied by the coverage factor $k=2$, which for a normal distribution corresponds to a coverage probability of approximately 95%.

Measurement Conditions

DASY system configuration, as far as not given on page 1.

DASY Version	DASY5	V52.10.2
Extrapolation	Advanced Extrapolation	
Phantom	Modular Flat Phantom	
Distance Dipole Center - TSL	10 mm	with Spacer
Zoom Scan Resolution	dx, dy, dz = 5 mm	
Frequency	2600 MHz \pm 1 MHz	

Head TSL parameters

The following parameters and calculations were applied.

	Temperature	Permittivity	Conductivity
Nominal Head TSL parameters	22.0 °C	39.0	1.96 mho/m
Measured Head TSL parameters	(22.0 \pm 0.2) °C	37.1 \pm 6 %	2.02 mho/m \pm 6 %
Head TSL temperature change during test	< 0.5 °C	----	----

SAR result with Head TSL

SAR averaged over 1 cm³ (1 g) of Head TSL	Condition	
SAR measured	250 mW input power	14.3 W/kg
SAR for nominal Head TSL parameters	normalized to 1W	55.8 W/kg \pm 17.0 % (k=2)

SAR averaged over 10 cm³ (10 g) of Head TSL	condition	
SAR measured	250 mW input power	6.38 W/kg
SAR for nominal Head TSL parameters	normalized to 1W	25.1 W/kg \pm 16.5 % (k=2)

Body TSL parameters

The following parameters and calculations were applied.

	Temperature	Permittivity	Conductivity
Nominal Body TSL parameters	22.0 °C	52.5	2.16 mho/m
Measured Body TSL parameters	(22.0 \pm 0.2) °C	50.4 \pm 6 %	2.20 mho/m \pm 6 %
Body TSL temperature change during test	< 0.5 °C	----	----

SAR result with Body TSL

SAR averaged over 1 cm³ (1 g) of Body TSL	Condition	
SAR measured	250 mW input power	14.0 W/kg
SAR for nominal Body TSL parameters	normalized to 1W	55.0 W/kg \pm 17.0 % (k=2)

SAR averaged over 10 cm³ (10 g) of Body TSL	condition	
SAR measured	250 mW input power	6.26 W/kg
SAR for nominal Body TSL parameters	normalized to 1W	24.8 W/kg \pm 16.5 % (k=2)

Appendix (Additional assessments outside the scope of SCS 0108)**Antenna Parameters with Head TSL**

Impedance, transformed to feed point	47.5 Ω - 6.3 j Ω
Return Loss	- 23.2 dB

Antenna Parameters with Body TSL

Impedance, transformed to feed point	43.8 Ω - 4.7 j Ω
Return Loss	- 21.6 dB

General Antenna Parameters and Design

Electrical Delay (one direction)	1.153 ns
----------------------------------	----------

After long term use with 100W radiated power, only a slight warming of the dipole near the feedpoint can be measured.

The dipole is made of standard semirigid coaxial cable. The center conductor of the feeding line is directly connected to the second arm of the dipole. The antenna is therefore short-circuited for DC-signals. On some of the dipoles, small end caps are added to the dipole arms in order to improve matching when loaded according to the position as explained in the "Measurement Conditions" paragraph. The SAR data are not affected by this change. The overall dipole length is still according to the Standard.

No excessive force must be applied to the dipole arms, because they might bend or the soldered connections near the feedpoint may be damaged.

Additional EUT Data

Manufactured by	SPEAG
-----------------	-------

DASY5 Validation Report for Head TSL

Date: 16.07.2019

Test Laboratory: SPEAG, Zurich, Switzerland

DUT: Dipole 2600 MHz; Type: D2600V2; Serial: D2600V2 - SN:1012

Communication System: UID 0 - CW; Frequency: 2600 MHz

Medium parameters used: $f = 2600$ MHz; $\sigma = 2.02$ S/m; $\epsilon_r = 37.1$; $\rho = 1000$ kg/m³

Phantom section: Flat Section

Measurement Standard: DASY5 (IEEE/IEC/ANSI C63.19-2011)

DASY52 Configuration:

- Probe: EX3DV4 - SN7349; ConvF(7.69, 7.69, 7.69) @ 2600 MHz; Calibrated: 29.05.2019
- Sensor-Surface: 1.4mm (Mechanical Surface Detection)
- Electronics: DAE4 Sn601; Calibrated: 30.04.2019
- Phantom: Flat Phantom 5.0 (front); Type: QD 000 P50 AA; Serial: 1001
- DASY52 52.10.2(1504); SEMCAD X 14.6.12(7470)

Dipole Calibration for Head Tissue/Pin=250 mW, d=10mm/Zoom Scan (7x7x7)/Cube 0:

Measurement grid: dx=5mm, dy=5mm, dz=5mm

Reference Value = 118.6 V/m; Power Drift = 0.00 dB

Peak SAR (extrapolated) = 28.8 W/kg

SAR(1 g) = 14.3 W/kg; SAR(10 g) = 6.38 W/kg

Maximum value of SAR (measured) = 24.0 W/kg

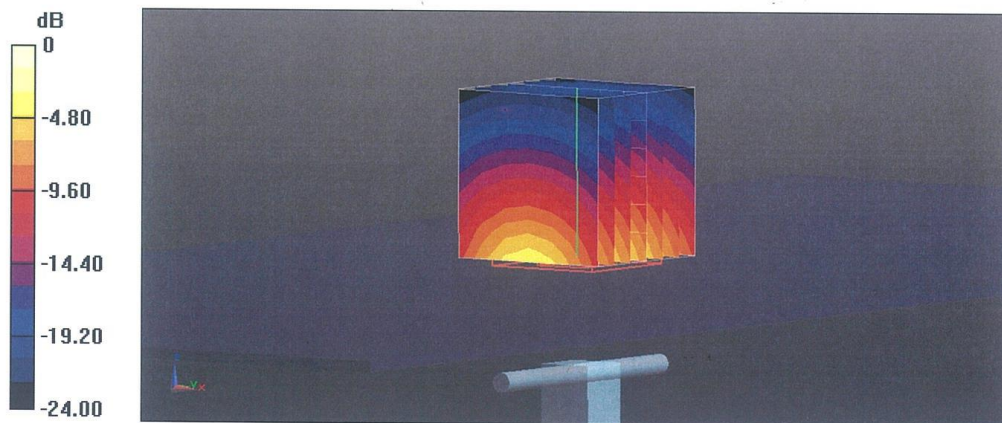

0 dB = 24.0 W/kg = 13.80 dBW/kg

Impedance Measurement Plot for Head TSL

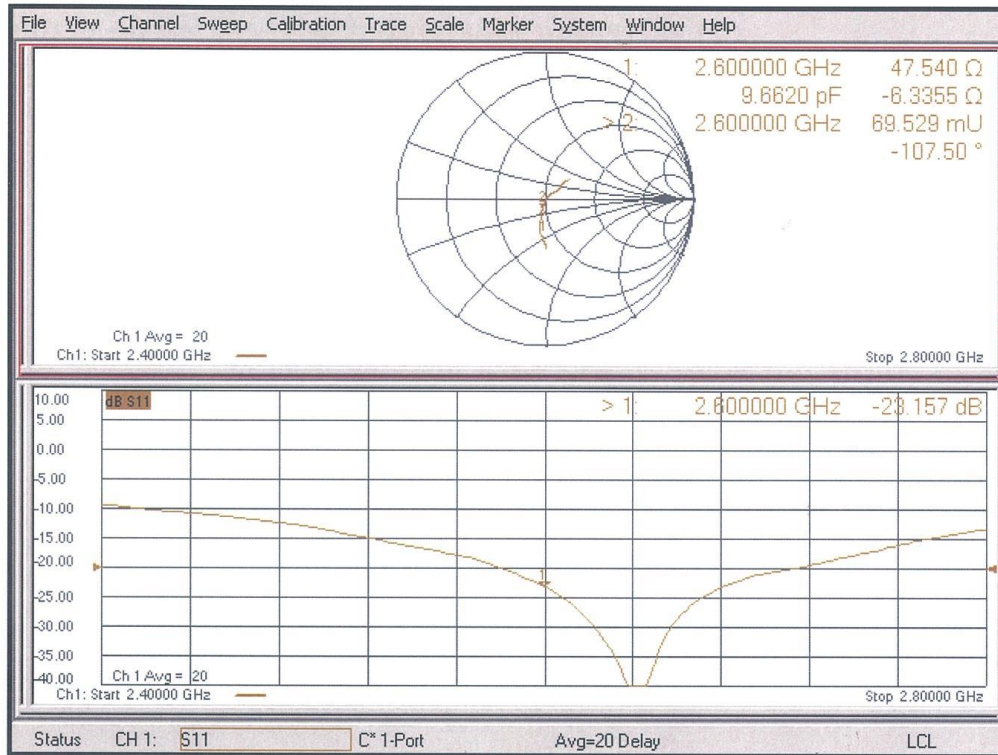

DASY5 Validation Report for Body TSL

Date: 17.07.2019

Test Laboratory: SPEAG, Zurich, Switzerland

DUT: Dipole 2600 MHz; Type: D2600V2; Serial: D2600V2 - SN:1012

Communication System: UID 0 - CW; Frequency: 2600 MHz

Medium parameters used: $f = 2600$ MHz; $\sigma = 2.2$ S/m; $\epsilon_r = 50.4$; $\rho = 1000$ kg/m³

Phantom section: Flat Section

Measurement Standard: DASY5 (IEEE/IEC/ANSI C63.19-2011)

DASY52 Configuration:

- Probe: EX3DV4 - SN7349; ConvF(7.8, 7.8, 7.8) @ 2600 MHz; Calibrated: 29.05.2019
- Sensor-Surface: 1.4mm (Mechanical Surface Detection)
- Electronics: DAE4 Sn601; Calibrated: 30.04.2019
- Phantom: Flat Phantom 5.0 (back); Type: QD 000 P50 AA; Serial: 1002
- DASY52 52.10.2(1504); SEMCAD X 14.6.12(7470)

Dipole Calibration for Body Tissue/Pin=250 mW, d=10mm/Zoom Scan (7x7x7)/Cube 0:

Measurement grid: dx=5mm, dy=5mm, dz=5mm

Reference Value = 110.1 V/m; Power Drift = -0.06 dB

Peak SAR (extrapolated) = 28.3 W/kg

SAR(1 g) = 14 W/kg; SAR(10 g) = 6.26 W/kg

Maximum value of SAR (measured) = 23.3 W/kg

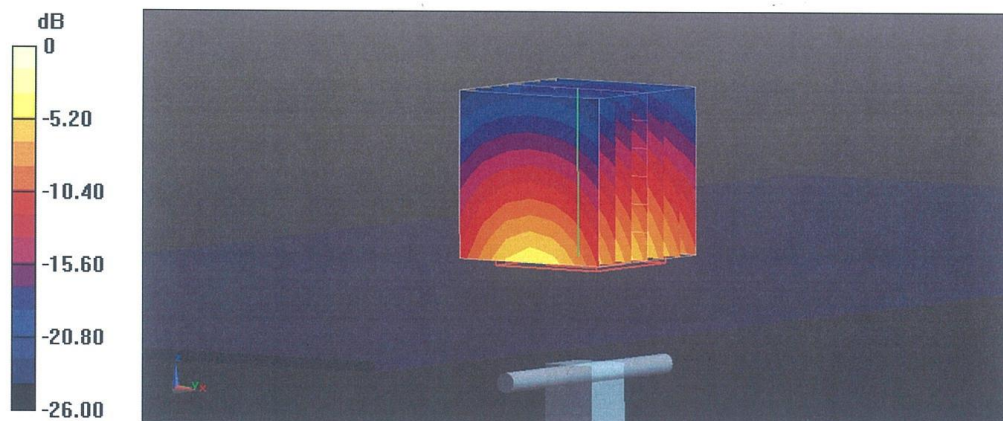

0 dB = 23.3 W/kg = 13.67 dBW/kg

Impedance Measurement Plot for Body TSL

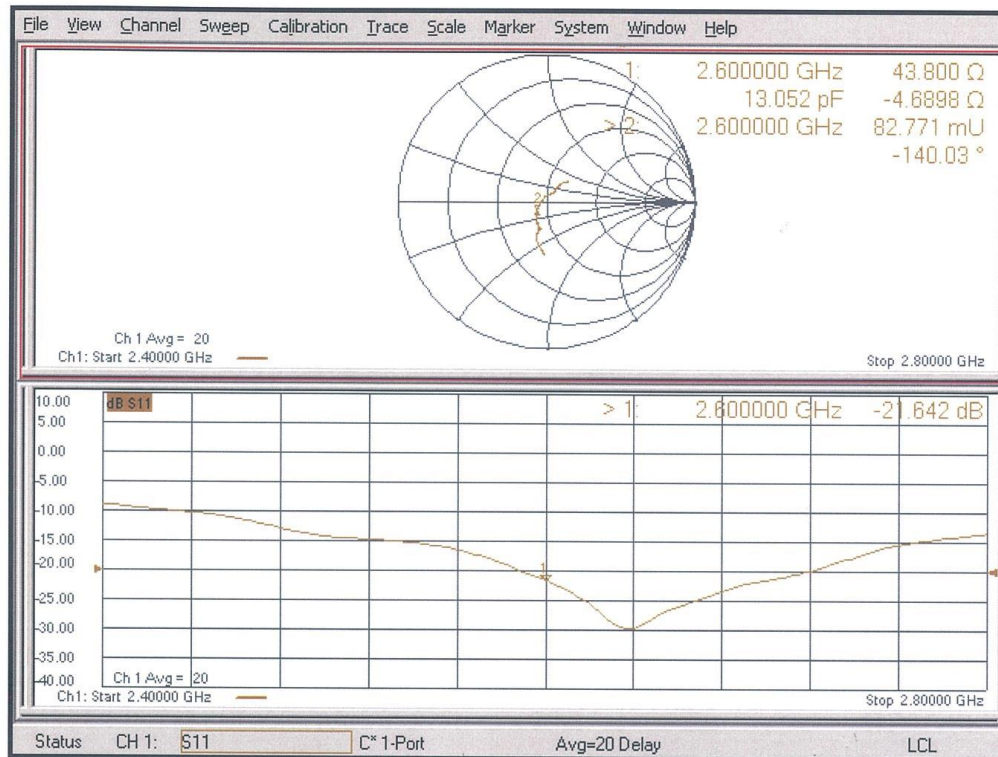

ANNEX I Variant Product Test

I.1 Dielectric Performance and System Validation

Table I.1-1: Dielectric Performance of Head Tissue Simulating Liquid

Measurement Date (yyyy-mm-dd)	Type	Frequency	Permittivity ϵ	Drift (%)	Conductivity σ (S/m)	Drift (%)
2019-11-19	Head	750 MHz	41.7	-0.57	0.898	0.90
2019-11-20	Head	835 MHz	41.6	0.24	0.901	0.11
2019-11-21	Head	1750 MHz	40.68	1.50	1.38	0.73
2019-11-22	Head	1900 MHz	39.55	-1.13	1.39	-0.71
2019-11-23	Head	2450 MHz	39.05	-0.38	1.784	-0.89
2019-11-23	Head	2600 MHz	39.57	1.44	1.966	0.31

Table I.1-2: System Validation of Head

Measurement Date (yyyy-mm-dd)	Frequency	Target value (W/kg)		Measured value(W/kg)		Deviation	
		10 g Average	1 g Average	10 g Average	1 g Average	10 g Average	1 g Average
2019-11-19	750 MHz	5.57	8.57	5.52	8.56	-0.90%	-0.12%
2019-11-20	835 MHz	6.29	9.70	6.28	9.8	-0.16%	1.03%
2019-11-21	1750 MHz	19.3	36.6	19.4	36.04	0.52%	-1.53%
2019-11-22	1900 MHz	20.8	39.7	20.6	40.28	-0.96%	1.46%
2019-11-23	2450 MHz	24.2	51.6	24.64	52.56	1.82%	1.86%
2019-11-23	2600 MHz	25.1	55.8	25.24	56.68	0.56%	1.58%

I.2 New frequency band

I.2.1 Conducted power of selected case

Band 28				
Bandwidth (MHz)	RB allocation	Frequency (MHz)	Actual output power (dBm)	
	RB offset		QPSK	16QAM
3MHz	1RB_High	746.5	22.78	21.42
		719.5	22.79	21.88
		704.5	22.72	21.81
	1RB_Middle	746.5	22.65	22.40
		719.5	22.72	21.95
		704.5	22.89	21.94
	1RB_Low	746.5	22.82	21.42
		719.5	22.73	21.82
		704.5	22.82	22.11
	8RB_High	746.5	21.68	20.56
		719.5	21.92	20.79

	8RB_Middle	704.5	21.74	20.99	
		746.5	21.87	20.81	
		719.5	22.01	20.85	
	8RB_Low	704.5	21.64	20.82	
		746.5	21.76	20.64	
		719.5	21.95	20.61	
	15RB	704.5	21.68	20.80	
		746.5	21.77	20.80	
		719.5	21.95	20.75	
5MHz	1RB_High	704.5	21.72	20.72	
		746.5	21.77	20.80	
		719.5	21.95	20.75	
	1RB_Middle	745.5	22.58	21.26	
		720.5	22.86	21.60	
		705.5	22.67	21.27	
	1RB_Low	745.5	23.00	21.54	
		720.5	23.04	21.64	
		705.5	22.88	21.05	
	12RB_High	745.5	22.66	21.21	
		720.5	22.82	21.40	
		705.5	22.73	21.05	
	12RB_Middle	745.5	21.81	20.84	
		720.5	21.86	20.71	
		705.5	21.65	20.62	
	12RB_Low	745.5	21.85	20.66	
		720.5	21.92	20.72	
		705.5	21.74	20.64	
	25RB	745.5	21.74	20.83	
		720.5	21.89	20.78	
		705.5	21.73	20.63	
	10MHz	1RB_High	745.5	21.82	20.86
			720.5	21.95	20.84
			705.5	21.68	20.60
		1RB_Middle	743	22.71	22.13
			723	22.96	21.78
			708	22.82	21.90
1RB_Low		743	22.80	21.44	
		723	23.05	22.10	
		708	22.76	21.90	
25RB_High	743	22.79	22.12		
	723	22.78	21.82		
	708	22.88	21.75		
	25RB_High	743	21.82	20.91	
		723	21.99	20.89	

	25RB_Middle	708	21.68	20.83	
		743	21.75	20.86	
		723	21.90	20.96	
	25RB_Low	708	21.66	20.69	
		743	21.80	20.73	
		723	21.97	20.94	
	50RB	708	21.54	20.53	
		743	21.80	20.80	
		723	21.95	20.87	
15MHz	1RB_High	708	21.54	20.61	
		743	21.80	20.80	
		723	21.95	20.87	
	1RB_Middle	740.5	22.90	21.82	
		725.5	22.83	22.33	
		710.5	22.65	22.46	
	1RB_Low	740.5	23.14	21.93	
		725.5	23.02	21.61	
		710.5	23.03	22.65	
	36RB_High	740.5	22.96	21.99	
		725.5	22.76	21.37	
		710.5	22.66	22.35	
	36RB_Middle	740.5	21.88	20.67	
		725.5	21.96	21.04	
		710.5	22.02	20.88	
	36RB_Low	740.5	21.81	20.77	
		725.5	21.99	21.07	
		710.5	21.90	20.72	
	75RB	740.5	21.77	20.74	
		725.5	21.85	20.96	
		710.5	21.74	20.68	
	20MHz	1RB_High	740.5	21.87	20.79
			725.5	21.90	20.87
			710.5	21.84	20.81
		1RB_Middle	738	22.56	21.96
			728	23.14	21.49
			713	22.62	21.37
1RB_Low		738	22.90	22.07	
		728	23.46	22.03	
		713	23.09	21.77	
50RB_High		738	22.49	21.40	
		728	23.05	21.74	
		713	22.62	21.12	
		738	22.03	20.80	
		728	22.01	21.07	

	50RB_Middle	713	21.97	20.85
		738	22.02	21.06
		728	21.98	21.09
		713	21.95	20.61
	50RB_Low	738	21.91	20.77
		728	21.94	20.68
		713	21.74	20.61
	100RB	738	21.90	20.89
		728	21.91	21.00
		713	21.88	20.85

I.2.2 SAR Test Result

Table I.2.2-1: SAR Values (LTE Band28 - Head)

Ambient Temperature: 22.9 °C Liquid Temperature: 22.5°C

Frequency		Mode	Side	Test Position	Figure No.	Conducted Power (dBm)	Max. tune-up Power (dBm)	Measured SAR(10g) (W/kg)	Reported SAR(10g) (W/kg)	Measured SAR(1g) (W/kg)	Reported SAR(1g) (W/kg)	Power Drift (dB)
Ch.	MHz											
27460	728	1RB_Mid	Left	Touch	Fig.1	23.46	24	0.097	0.11	0.123	0.14	0.01
27460	728	1RB_Mid	Left	Tilt	/	23.46	24	0.073	0.08	0.090	0.10	-0.09
27460	728	1RB_Mid	Right	Touch	/	23.46	24	0.070	0.08	0.087	0.10	-0.10
27460	728	1RB_Mid	Right	Tilt	/	23.46	24	0.054	0.06	0.068	0.08	-0.04
27560	738	50RB_High	Left	Touch	/	22.03	23	0.083	0.10	0.105	0.13	-0.04
27560	738	50RB_High	Left	Tilt	/	22.03	23	0.070	0.09	0.088	0.11	-0.05
27560	738	50RB_High	Right	Touch	/	22.03	23	0.060	0.08	0.077	0.10	0.03
27560	738	50RB_High	Right	Tilt	/	22.03	23	0.052	0.07	0.066	0.08	-0.10

Note1: The LTE mode is QPSK_20MHz.

Table I.2.2-2: SAR Values (LTE Band28 - Body)

Ambient Temperature: 22.9 °C Liquid Temperature: 22.5°C

Frequency		Mode	Test Position	Figure No.	Conducted Power (dBm)	Max. tune-up Power (dBm)	Measured SAR(10g) (W/kg)	Reported SAR(10g) (W/kg)	Measured SAR(1g) (W/kg)	Reported SAR(1g) (W/kg)	Power Drift (dB)
Ch.	MHz										
27460	728	1RB_Mid	Front	/	23.46	24	0.102	0.12	0.136	0.15	0.08
27460	728	1RB_Mid	Rear	Fig.2	23.46	24	0.153	0.17	0.202	0.23	0.07
27460	728	1RB_Mid	Left	/	23.46	24	0.086	0.10	0.130	0.15	-0.08

27460	728	1RB_Mid	Right	/	23.46	24	0.061	0.07	0.086	0.10	-0.06
27460	728	1RB_Mid	Bottom	/	23.46	24	0.032	0.04	0.054	0.06	0.05
27560	738	50RB_High	Front	/	22.03	23	0.090	0.11	0.120	0.15	0.12
27560	738	50RB_High	Rear	/	22.03	23	0.134	0.17	0.179	0.22	0.02
27560	738	50RB_High	Left	/	22.03	23	0.120	0.15	0.169	0.21	0.00
27560	738	50RB_High	Right	/	22.03	23	0.058	0.07	0.081	0.10	-0.02
27560	738	50RB_High	Bottom	/	22.03	23	0.031	0.04	0.054	0.07	-0.02

Note1: The distance between the EUT and the phantom bottom is 10mm

Note2: The LTE mode is QPSK_20MHz.

I.3 Spot Check

I.3.1 Conducted power of selected case

Table I.3-1: The conducted power results for 2G- Normal Power

GSM 850MHZ	Measured Power (dBm)		
	251	190	128
Speech	32.05	/	/
GPRS(2Tx)	29.17	/	/
GSM1900MHZ	Measured Power (dBm)		
	810	661	512
Speech	/	/	28.61
GPRS(2Tx)	/	/	26.86

Table I.3-2: The conducted Power for WCDMA- Normal Power

Item	band	FDDII result		
	ARFCN	9538/9938	9400/9800	9262/9662
WCDMA	\	(1907.6MHz)	(1880MHz)	(1852.4MHz)
		/	22.62	22.69
Item	band	FDDIV result		
	ARFCN	1513/1738	1412/1637	1312/1537
WCDMA	\	(1752.6MHz)	(1732.4MHz)	(1712.4MHz)
		22.84	/	/
Item	band	FDDV result		
	ARFCN	4233/4458	4183/4408	4132/4357
WCDMA	\	(846.6MHz)	(836.6MHz)	(826.4MHz)
		22.75	/	22.66

Table I.3-3: The conducted Power for WCDMA- Low Power

Item	band	FDDII result		
	ARFCN	9538/9938	9400/9800	9262/9662
WCDMA	\	(1907.6MHz)	(1880MHz)	(1852.4MHz)
		19.02	/	/
Item	band	FDDIV result		
	ARFCN	1513/1738	1412/1637	1312/1537

WCDMA	\	(1752.6MHz)	(1732.4MHz)	(1712.4MHz)
		18.93	/	/

Table I.3-4: The conducted Power for LTE-Normal Power

LTE Band2	1RB-Middle	1900(19100)	22.97
LTE Band5	1RB-Middle	829(20450)	22.97
LTE Band7	1RB-Middle	2535 (21100)	22.80
LTE Band7	1RB-Middle	2560 (21350)	23.19
LTE Band13	1RB-Middle	782 (23230)	23.07
LTE Band17	1RB-Middle	709 (23780)	22.79
LTE Band66	1RB-Middle	1770 (132572)	22.92

Table I.3-5: The conducted Power for LTE-Low Power

LTE Band2	50RB-Middle	1900(19100)	19.34
LTE Band7	50RB-Middle	2535 (21100)	18.68
LTE Band66	1RB-Middle	1745 (132322)	19.95

Table I.3-6: The conducted Power for WLAN

Mode / data rate	Channel	Measured Power (dBm)
802.11b – 1Mbps	6	16.12

F.3.2 Measurement results

Test Band	Channel	Frequency	Tune-Up	Measured Power	Test Position	Measured 10g SAR	Measured 1g SAR	Reported 10g SAR	Reported 1g SAR	Power Drift
GSM850	251	848.8	33.3	32.13	Left Cheek	0.304	0.401	0.41	0.53	0.02
GSM850	251	848.8	30.5	29.52	Rear	0.264	0.481	0.36	0.65	0.09
PCS1900	512	1850.2	30.3	28.75	Left Cheek	0.081	0.132	0.12	0.19	0.09
PCS1900	512	1850.2	28	27.02	Bottom	0.365	0.694	0.47	0.90	0.01
WCDMA1900-BII	9400	1880	24	22.42	Left Cheek	0.138	0.219	0.19	0.30	0.04
WCDMA1900-BII	9538	1907.6	20	19.32	Bottom	0.112	0.215	0.14	0.27	0.14
WCDMA1900-BII	9262	1852.4	24	22.65	Rear	0.292	0.512	0.39	0.69	-0.02
WCDMA1700-BIV	1513	1752.6	24	22.95	Left Cheek	0.114	0.177	0.15	0.23	-0.08
WCDMA1700-BIV	1513	1752.6	20	19.25	Rear	0.195	0.358	0.25	0.46	-0.04
WCDMA1700-BIV	1513	1752.6	24	22.95	Rear	0.236	0.414	0.31	0.54	-0.02
WCDMA850-BV	4132	826.4	24	22.6	Left Cheek	0.185	0.257	0.25	0.35	-0.05
WCDMA850-BV	4233	846.6	24	22.54	Rear	0.232	0.422	0.31	0.56	-0.02
LTE1900-FDD2	19100	1900 MHz	24	23.06	Right Cheek	0.111	0.178	0.14	0.23	0.02
LTE1900-FDD2	19100	1900 MHz	20	18.78	Bottom	0.192	0.382	0.22	0.44	0.12
LTE1900-FDD2	19100	1900 MHz	24	23.06	Rear	0.268	0.465	0.34	0.59	-0.01
LTE850-FDD5	20450	829 MHz	24	22.51	Left Cheek	0.226	0.305	0.29	0.39	0.03
LTE850-FDD5	20450	829 MHz	24	22.51	Rear	0.316	0.415	0.40	0.53	0.06
LTE2500-FDD7	21100	2535 MHz	24	22.81	Right Cheek	0.0319	0.0633	0.04	0.08	0.03
LTE2500-FDD7	21100	2535 MHz	19.5	18.84	Bottom	0.236	0.509	0.29	0.61	0.05
LTE2500-FDD7	21350	2560 MHz	24	22.89	Rear	0.419	0.817	0.50	0.98	0.05
LTE750-FDD13	23230	782 MHz	24	23.1	Left Cheek	0.151	0.195	0.19	0.24	0.04
LTE750-FDD13	23230	782 MHz	24	23.1	Rear	0.235	0.307	0.29	0.38	0.07
LTE700-FDD17	23780	709 MHz	24	22.67	Left Cheek	0.0666	0.0864	0.09	0.11	0.08
LTE700-FDD17	23780	709 MHz	24	22.67	Rear	0.0676	0.108	0.09	0.14	-0.16
LTE1700-FDD66	132572	709 MHz	24	22.85	Left Cheek	0.17	0.271	0.22	0.35	0.03
LTE1700-FDD66	132322	709 MHz	20	19.07	Rear	0.154	0.287	0.16	0.29	-0.03
LTE1700-FDD66	132572	709 MHz	24	22.85	Rear	0.245	0.421	0.31	0.54	-0.14
WLAN2450	6	2437	17.5	15.73	Right Tilt	0.162	0.412	0.22	0.57	0.09
WLAN2450	6	2437	17.5	15.73	Top	0.0894	0.198	0.12	0.27	0.03

F.3.3 Reported SAR Comparison

Table F.4-1: Comparison

Exposure Configuration	Technology Band	Reported SAR 10g(W/kg) Original	Reported SAR 10g(W/kg) Spot check	Equipment Class
Head (Separation Distance 0mm)	GSM 850	0.60	0.53	PCE
	PCS 1900	0.15	0.19	
	UMTS FDD 2	0.31	0.30	
	UMTS FDD 4	0.40	0.23	
	UMTS FDD 5	0.43	0.35	
	LTE Band 2	0.29	0.23	
	LTE Band 5	0.44	0.39	
	LTE Band 7	0.09	0.08	
	LTE Band 13	0.30	0.24	
	LTE Band 17	0.14	0.11	
	LTE Band 66	0.35	0.35	
	WLAN 2.4 GHz	0.41	0.57	DTS
Hotspot (Separation Distance 10mm)	GSM 850	0.59	0.65	PCE
	PCS 1900	0.78	0.90	
	UMTS FDD 2	0.65	0.27	
	UMTS FDD 4	0.32	0.46	
	UMTS FDD 5	0.63	0.56	
	LTE Band 2	0.65	0.44	
	LTE Band 5	0.56	0.53	
	LTE Band 7	0.90	0.61	
	LTE Band 13	0.56	0.38	
	LTE Band 17	0.22	0.14	
	LTE Band 66	0.37	0.29	
	WLAN 2.4 GHz	0.22	0.27	DTS
Body-worn (Separation Distance 15mm)	UMTS FDD 2	0.62	0.69	PCE
	UMTS FDD 4	0.59	0.54	
	LTE Band 2	0.59	0.59	
	LTE Band 7	1.32	0.98	
	LTE Band 66	0.52	0.54	

Note: The spot check results marked by blue are larger than the original result. So they replace the original result and others are shared.

I.4 List of Main Instruments

Table F.4.1: List of Main Instruments

No.	Name	Type	Serial Number	Calibration Date	Valid Period
01	Network analyzer	E5071C	MY46110673	January 24, 2019	One year
02	Power meter	NRP2	106277	September 4, 2019	One year
03	Power sensor	NRP8S	104291		
04	Signal Generator	E4438C	MY49070393	January 4, 2019	One Year
05	Amplifier	60S1G4	0331848	No Calibration Requested	
06	BTS	E5515C	MY50263375	January 17, 2019	One year
07	BTS	CMW500	159890	January 3, 2019	One year
08	E-field Probe	SPEAG EX3DV4	3617	January 31, 2019	One year
09	DAE	SPEAG DAE4	771	January 11,2019	One year
10	Dipole Validation Kit	SPEAG D750V3	1017	July 18, 2019	One year
11	Dipole Validation Kit	SPEAG D835V2	4d069	July 18, 2019	One year
12	Dipole Validation Kit	SPEAG D1750V2	1003	July 16, 2019	One year
13	Dipole Validation Kit	SPEAG D1900V2	5d101	July 17, 2019	One year
14	Dipole Validation Kit	SPEAG D2450V2	853	July 17, 2019	One year
15	Dipole Validation Kit	SPEAG D2600V2	1012	July 17, 2019	One year

I.5 GRAPH RESULTS

GSM850_CH251 Left Cheek

Date: 11/20/2019

Electronics: DAE4 Sn771

Medium: head 835 MHz

Medium parameters used: $f = 848.8$; $\sigma = 0.914$ mho/m; $\epsilon_r = 41.58$; $\rho = 1000$ kg/m³

Ambient Temperature: 22.5°C, Liquid Temperature: 22.3°C

Communication System: GSM850 848.8 Duty Cycle: 1:8.3

Probe: EX3DV4 – SN3617 ConvF(9.75,9.75,9.75)

Area Scan (71x121x1): Interpolated grid: dx=1.000 mm, dy=1.000 mm

Maximum value of SAR (interpolated) = 0.491 W/kg

Zoom Scan (7x7x7)/Cube 0: Measurement grid: dx=5mm, dy=5mm, dz=5mm

Reference Value = 4.165 V/m; Power Drift = 0.02 dB

Peak SAR (extrapolated) = 0.533 W/kg

SAR(1 g) = 0.401 W/kg; SAR(10 g) = 0.304 W/kg

Maximum value of SAR (measured) = 0.486 W/kg

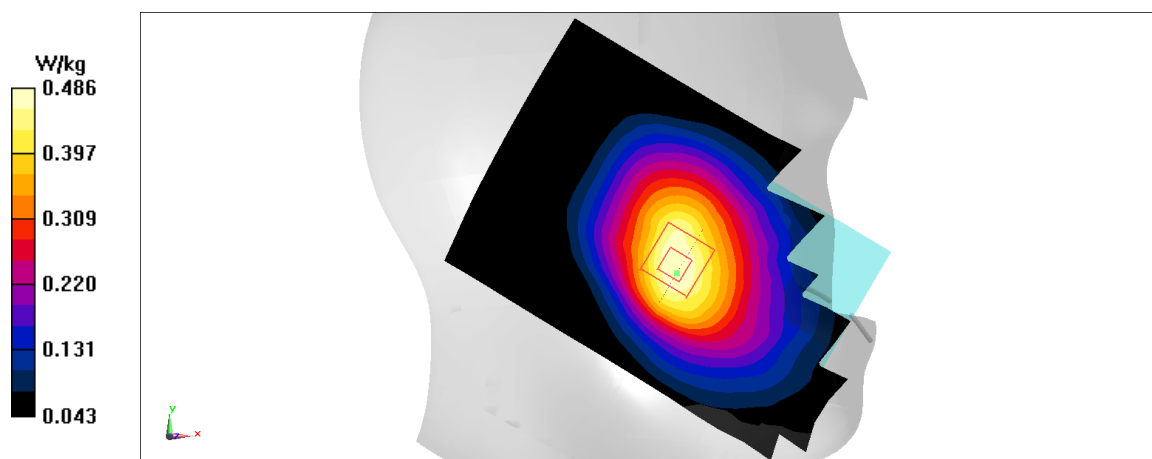

Fig A.1

GSM850_CH251 Rear

Date: 11/20/2019

Electronics: DAE4 Sn771

Medium: body 835 MHz

Medium parameters used: $f = 848.8$; $\sigma = 0.914$ mho/m; $\epsilon_r = 41.58$; $\rho = 1000$ kg/m³

Ambient Temperature: 22.5°C, Liquid Temperature: 22.3°C

Communication System: GSM850 848.8 Duty Cycle: 1:4

Probe: EX3DV4 – SN3617 ConvF(9.61,9.61,9.61)

Area Scan (71x121x1): Interpolated grid: dx=1.000 mm, dy=1.000 mm

Maximum value of SAR (interpolated) = 0.711 W/kg

Zoom Scan (7x7x7)/Cube 0: Measurement grid: dx=5mm, dy=5mm, dz=5mm

Reference Value = 21.94 V/m; Power Drift = 0.09 dB

Peak SAR (extrapolated) = 0.925 W/kg

SAR(1 g) = 0.481 W/kg; SAR(10 g) = 0.264 W/kg

Maximum value of SAR (measured) = 0.737 W/kg

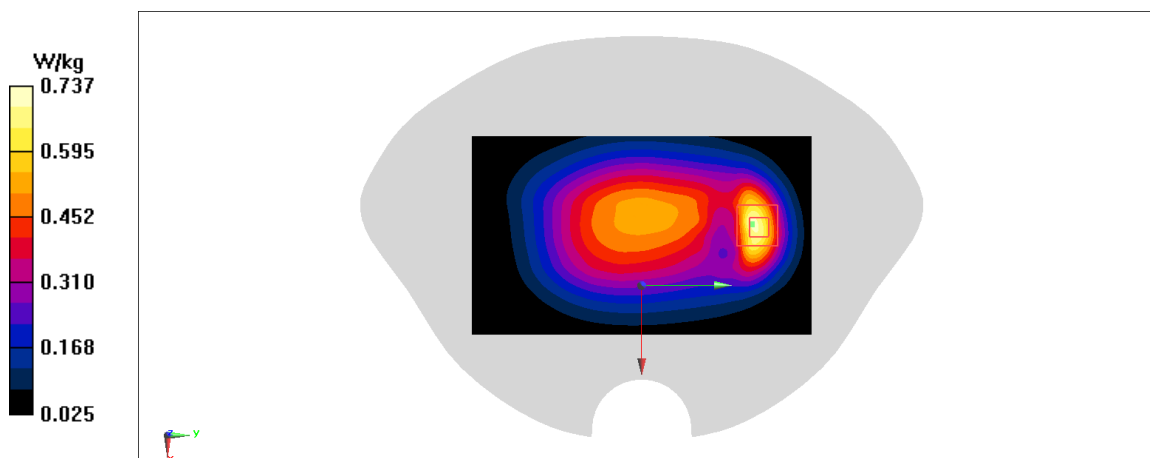
**Fig A.2**

PCS1900_CH512 Left Cheek

Date: 11/22/2019

Electronics: DAE4 Sn771

Medium: head 1900 MHz

Medium parameters used: $f = 1850.2$; $\sigma = 1.342$ mho/m; $\epsilon_r = 39.61$; $\rho = 1000$ kg/m³

Ambient Temperature: 22.5°C, Liquid Temperature: 22.3°C

Communication System: PCS1900 1850.2 Duty Cycle: 1:8.3

Probe: EX3DV4 – SN3617 ConvF(8.14,8.14,8.14)

Area Scan (71x121x1): Interpolated grid: dx=1.000 mm, dy=1.000 mm

Maximum value of SAR (interpolated) = 0.181 W/kg

Zoom Scan (7x7x7)/Cube 0: Measurement grid: dx=5mm, dy=5mm, dz=5mm

Reference Value = 2.46 V/m; Power Drift = 0.09 dB

Peak SAR (extrapolated) = 0.214 W/kg

SAR(1 g) = 0.132 W/kg; SAR(10 g) = 0.081 W/kg

Maximum value of SAR (measured) = 0.182 W/kg

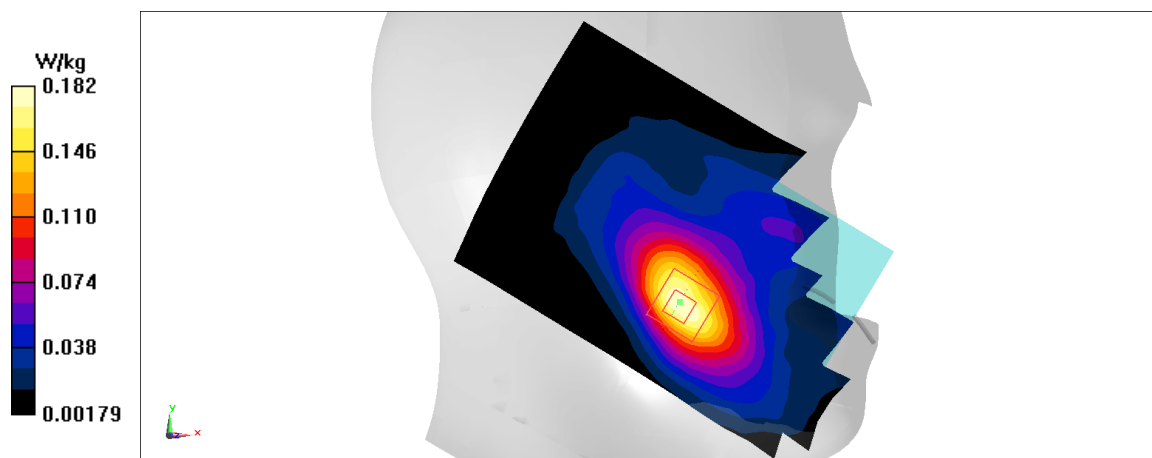
**Fig A.3**

PCS1900_CH512 Bottom

Date: 11/22/2019

Electronics: DAE4 Sn771

Medium: body 1900 MHz

Medium parameters used: $f = 1850.2$; $\sigma = 1.342$ mho/m; $\epsilon_r = 39.61$; $\rho = 1000$ kg/m³

Ambient Temperature: 22.5°C, Liquid Temperature: 22.3°C

Communication System: PCS1900 1850.2 Duty Cycle: 1:4

Probe: EX3DV4 – SN3617 ConvF(7.78,7.78,7.78)

Area Scan (71x121x1): Interpolated grid: dx=1.000 mm, dy=1.000 mm

Maximum value of SAR (interpolated) = 0.96 W/kg

Zoom Scan (7x7x7)/Cube 0: Measurement grid: dx=5mm, dy=5mm, dz=5mm

Reference Value = 19.63 V/m; Power Drift = 0.01 dB

Peak SAR (extrapolated) = 1.21 W/kg

SAR(1 g) = 0.694 W/kg; SAR(10 g) = 0.365 W/kg

Maximum value of SAR (measured) = 0.982 W/kg

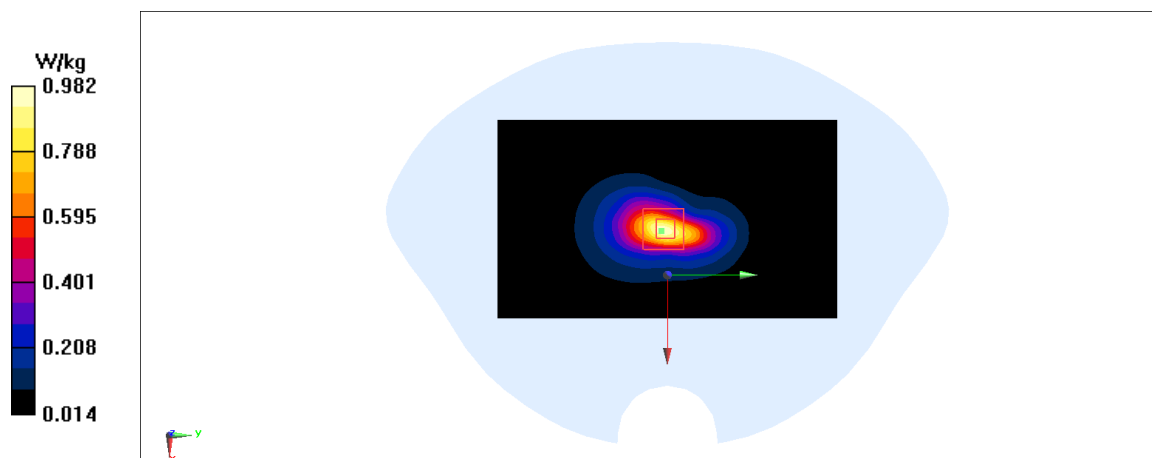
**Fig A.4**

WCDMA1900-BII_CH9400 Left Cheek

Date: 11/22/2019

Electronics: DAE4 Sn771

Medium: head 1900 MHz

Medium parameters used: $f = 1880$; $\sigma = 1.371$ mho/m; $\epsilon_r = 39.57$; $\rho = 1000$ kg/m³

Ambient Temperature: 22.5°C, Liquid Temperature: 22.3°C

Communication System: WCDMA1900-BII 1880 Duty Cycle: 1:1

Probe: EX3DV4 – SN3617 ConvF(8.14,8.14,8.14)

Area Scan (71x121x1): Interpolated grid: dx=1.000 mm, dy=1.000 mm

Maximum value of SAR (interpolated) = 0.306 W/kg

Zoom Scan (7x7x7)/Cube 0: Measurement grid: dx=5mm, dy=5mm, dz=5mm

Reference Value = 2.935 V/m; Power Drift = 0.04 dB

Peak SAR (extrapolated) = 0.352 W/kg

SAR(1 g) = 0.219 W/kg; SAR(10 g) = 0.138 W/kg

Maximum value of SAR (measured) = 0.299 W/kg

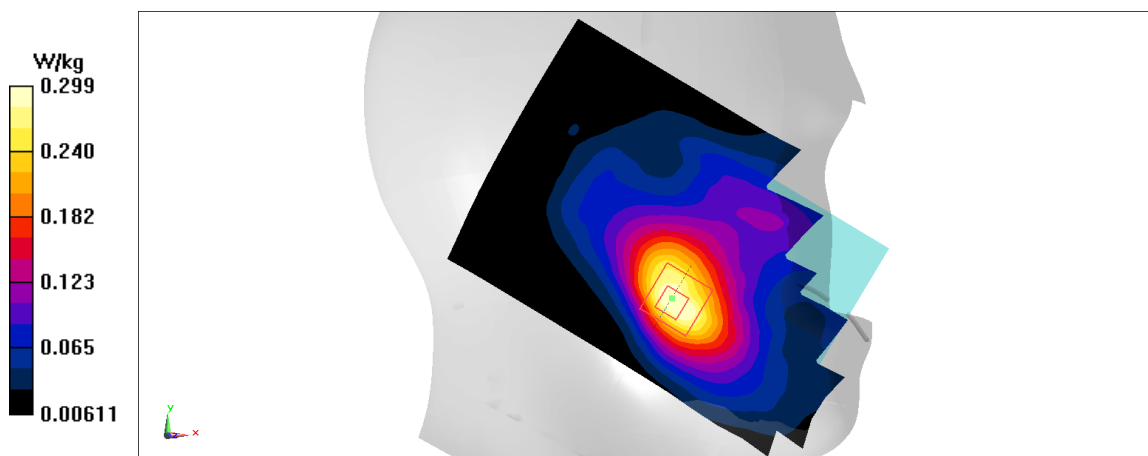
**Fig A.5**

WCDMA1900-BII_CH9538 Bottom

Date: 11/22/2019

Electronics: DAE4 Sn771

Medium: body 1900 MHz

Medium parameters used: $f = 1907.6$; $\sigma = 1.398$ mho/m; $\epsilon_r = 39.54$; $\rho = 1000$ kg/m³

Ambient Temperature: 22.5°C, Liquid Temperature: 22.3°C

Communication System: WCDMA1900-BII 1907.6 Duty Cycle: 1:1

Probe: EX3DV4 – SN3617 ConvF(7.78,7.78,7.78)

Area Scan (71x121x1): Interpolated grid: dx=1.000 mm, dy=1.000 mm

Maximum value of SAR (interpolated) = 0.296 W/kg

Zoom Scan (7x7x7)/Cube 0: Measurement grid: dx=5mm, dy=5mm, dz=5mm

Reference Value = 11.74 V/m; Power Drift = 0.14 dB

Peak SAR (extrapolated) = 0.374 W/kg

SAR(1 g) = 0.215 W/kg; SAR(10 g) = 0.112 W/kg

Maximum value of SAR (measured) = 0.304 W/kg

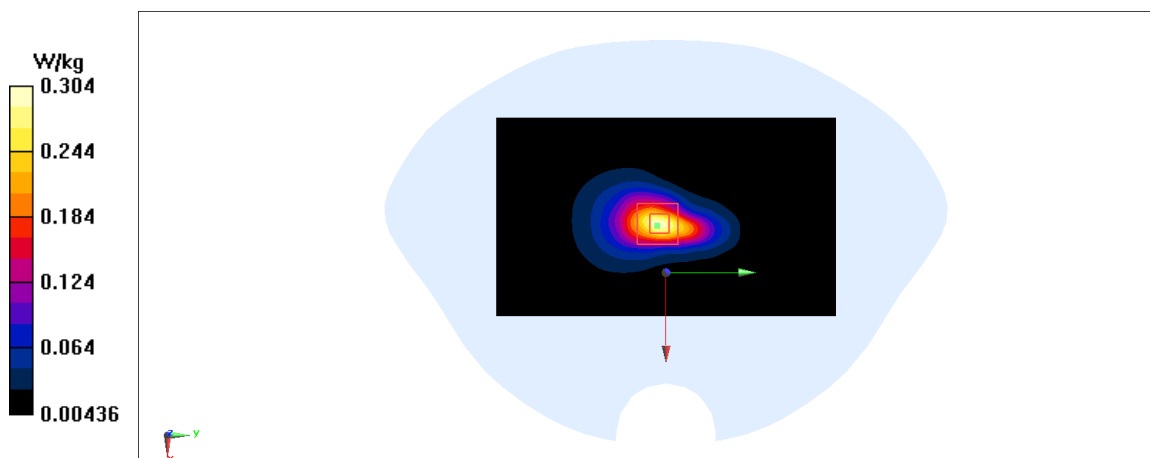

Fig A.6

WCDMA1900-BII_CH9262 Rear

Date: 11/22/2019

Electronics: DAE4 Sn771

Medium: body 1900 MHz

Medium parameters used: $f = 1852.4$; $\sigma = 1.344$ mho/m; $\epsilon_r = 39.61$; $\rho = 1000$ kg/m³

Ambient Temperature: 22.5°C, Liquid Temperature: 22.3°C

Communication System: WCDMA1900-BII 1852.4 Duty Cycle: 1:1

Probe: EX3DV4 – SN3617 ConvF(7.78,7.78,7.78)

Area Scan (71x121x1): Interpolated grid: dx=1.000 mm, dy=1.000 mm

Maximum value of SAR (interpolated) = 0.795 W/kg

Zoom Scan (7x7x7)/Cube 0: Measurement grid: dx=5mm, dy=5mm, dz=5mm

Reference Value = 8.864 V/m; Power Drift = -0.02 dB

Peak SAR (extrapolated) = 0.911 W/kg

SAR(1 g) = 0.512 W/kg; SAR(10 g) = 0.292 W/kg

Maximum value of SAR (measured) = 0.764 W/kg

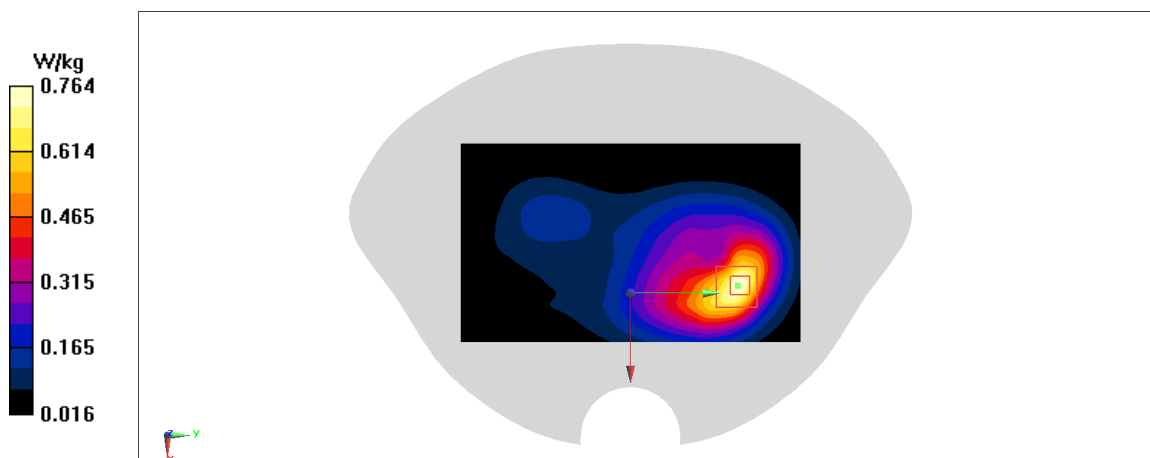
**Fig A.7**

WCDMA1700-BIV_CH1513 Left Cheek

Date: 11/21/2019

Electronics: DAE4 Sn771

Medium: head 1750 MHz

Medium parameters used: $f = 1752.6$; $\sigma = 1.383$ mho/m; $\epsilon_r = 40.68$; $\rho = 1000$ kg/m³

Ambient Temperature: 22.5°C, Liquid Temperature: 22.3°C

Communication System: WCDMA1700-BIV 1752.6 Duty Cycle: 1:1

Probe: EX3DV4 – SN3617 ConvF(8.38,8.38,8.38)

Area Scan (71x121x1): Interpolated grid: dx=1.000 mm, dy=1.000 mm

Maximum value of SAR (interpolated) = 0.235 W/kg

Zoom Scan (7x7x7)/Cube 0: Measurement grid: dx=5mm, dy=5mm, dz=5mm

Reference Value = 5.312 V/m; Power Drift = -0.08 dB

Peak SAR (extrapolated) = 0.27 W/kg

SAR(1 g) = 0.177 W/kg; SAR(10 g) = 0.114 W/kg

Maximum value of SAR (measured) = 0.238 W/kg

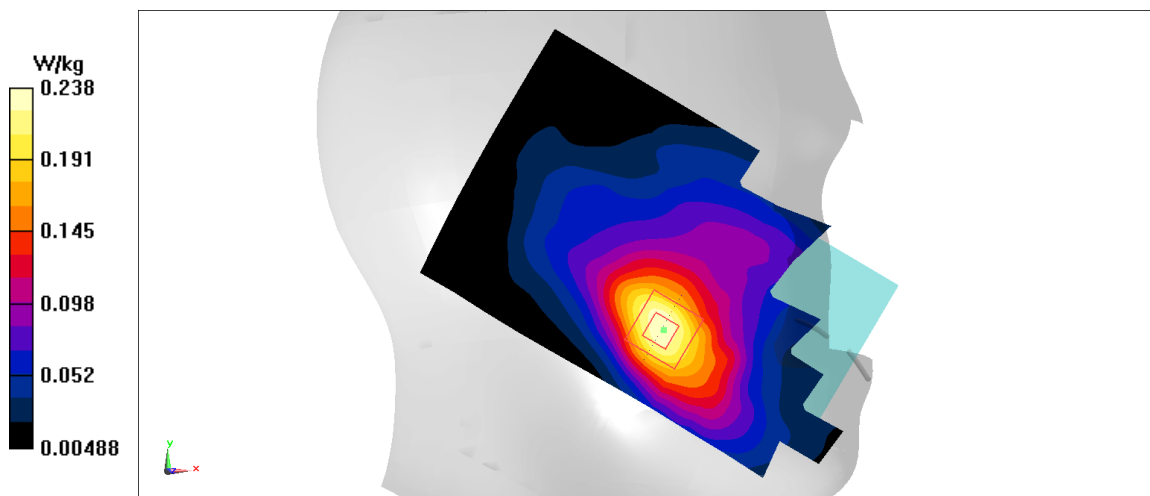

Fig A.8

WCDMA1700-BIV_CH1513 Rear

Date: 11/21/2019

Electronics: DAE4 Sn771

Medium: body 1750 MHz

Medium parameters used: $f = 1752.6$; $\sigma = 1.383$ mho/m; $\epsilon_r = 40.68$; $\rho = 1000$ kg/m³

Ambient Temperature: 22.5°C, Liquid Temperature: 22.3°C

Communication System: WCDMA1700-BIV 1752.6 Duty Cycle: 1:1

Probe: EX3DV4 – SN3617 ConvF(8.03,8.03,8.03)

Area Scan (71x121x1): Interpolated grid: dx=1.000 mm, dy=1.000 mm

Maximum value of SAR (interpolated) = 0.546 W/kg

Zoom Scan (7x7x7)/Cube 0: Measurement grid: dx=5mm, dy=5mm, dz=5mm

Reference Value = 5.569 V/m; Power Drift = -0.04 dB

Peak SAR (extrapolated) = 0.659 W/kg

SAR(1 g) = 0.358 W/kg; SAR(10 g) = 0.195 W/kg

Maximum value of SAR (measured) = 0.528 W/kg

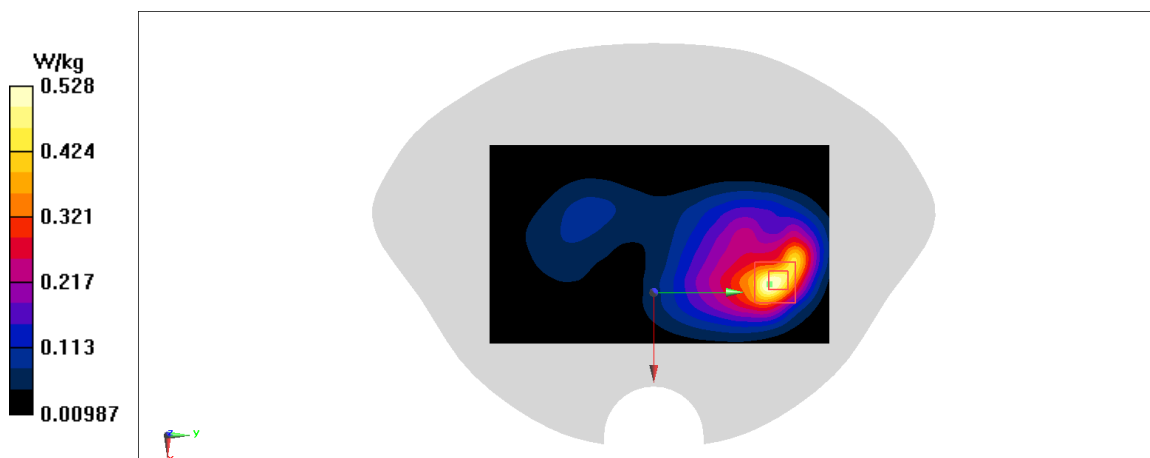
**Fig A.9**

WCDMA1700-BIV_CH1513 Rear

Date: 11/21/2019

Electronics: DAE4 Sn771

Medium: body 1750 MHz

Medium parameters used: $f = 1752.6$; $\sigma = 1.383$ mho/m; $\epsilon_r = 40.68$; $\rho = 1000$ kg/m³

Ambient Temperature: 22.5°C, Liquid Temperature: 22.3°C

Communication System: WCDMA1700-BIV 1752.6 Duty Cycle: 1:1

Probe: EX3DV4 – SN3617 ConvF(8.03,8.03,8.03)

Area Scan (71x121x1): Interpolated grid: dx=1.000 mm, dy=1.000 mm

Maximum value of SAR (interpolated) = 0.626 W/kg

Zoom Scan (7x7x7)/Cube 0: Measurement grid: dx=5mm, dy=5mm, dz=5mm

Reference Value = 8.86 V/m; Power Drift = -0.02 dB

Peak SAR (extrapolated) = 0.741 W/kg

SAR(1 g) = 0.414 W/kg; SAR(10 g) = 0.236 W/kg

Maximum value of SAR (measured) = 0.616 W/kg

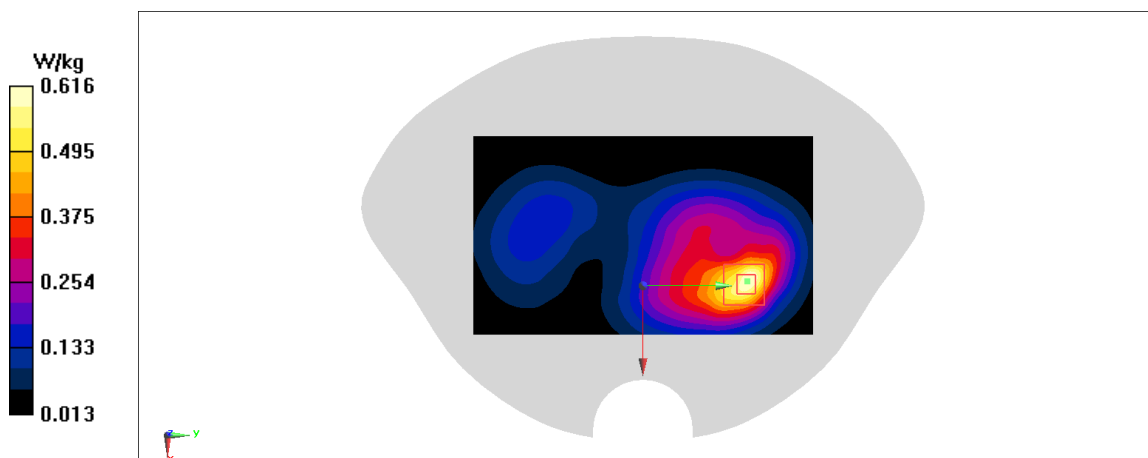
**Fig A.10**

WCDMA850-BV_CH4132 Left Cheek

Date: 11/20/2019

Electronics: DAE4 Sn771

Medium: head 835 MHz

Medium parameters used: $f = 826.4$; $\sigma = 0.892$ mho/m; $\epsilon_r = 41.61$; $\rho = 1000$ kg/m³

Ambient Temperature: 22.5°C, Liquid Temperature: 22.3°C

Communication System: WCDMA850-BV 826.4 Duty Cycle: 1:1

Probe: EX3DV4 – SN3617 ConvF(9.75,9.75,9.75)

Area Scan (71x121x1): Interpolated grid: dx=1.000 mm, dy=1.000 mm

Maximum value of SAR (interpolated) = 0.272 W/kg

Zoom Scan (7x7x7)/Cube 0: Measurement grid: dx=5mm, dy=5mm, dz=5mm

Reference Value = 6.375 V/m; Power Drift = -0.05 dB

Peak SAR (extrapolated) = 0.459 W/kg

SAR(1 g) = 0.257 W/kg; SAR(10 g) = 0.185 W/kg

Maximum value of SAR (measured) = 0.274 W/kg

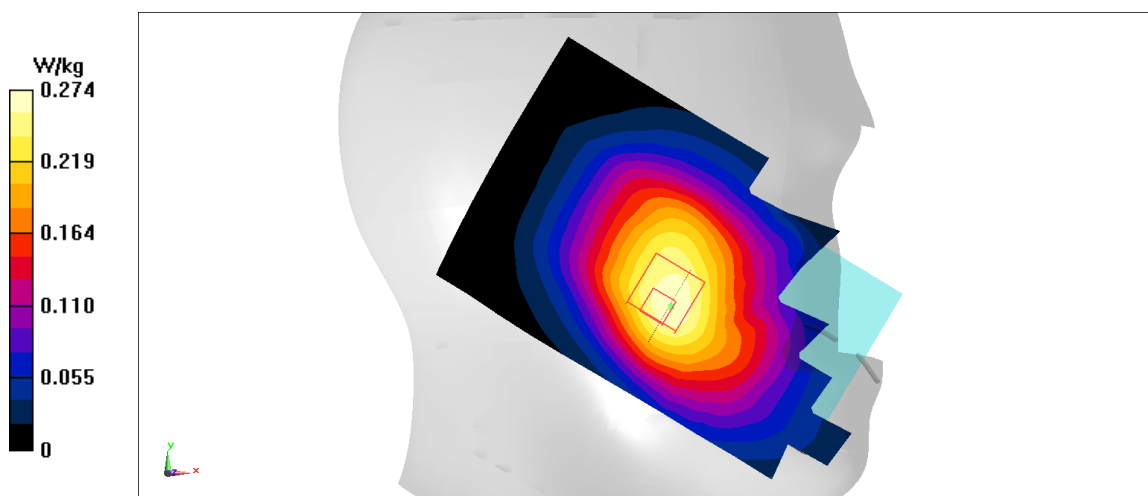
**Fig A.11**

WCDMA850-BV_CH4233 Rear

Date: 11/20/2019

Electronics: DAE4 Sn771

Medium: body 835 MHz

Medium parameters used: $f = 846.6$; $\sigma = 0.912$ mho/m; $\epsilon_r = 41.59$; $\rho = 1000$ kg/m³

Ambient Temperature: 22.5°C, Liquid Temperature: 22.3°C

Communication System: WCDMA850-BV 846.6 Duty Cycle: 1:1

Probe: EX3DV4 – SN3617 ConvF(9.61,9.61,9.61)

Area Scan (71x121x1): Interpolated grid: dx=1.000 mm, dy=1.000 mm

Maximum value of SAR (interpolated) = 0.617 W/kg

Zoom Scan (7x7x7)/Cube 0: Measurement grid: dx=5mm, dy=5mm, dz=5mm

Reference Value = 22.36 V/m; Power Drift = -0.02 dB

Peak SAR (extrapolated) = 0.821 W/kg

SAR(1 g) = 0.422 W/kg; SAR(10 g) = 0.232 W/kg

Maximum value of SAR (measured) = 0.65 W/kg

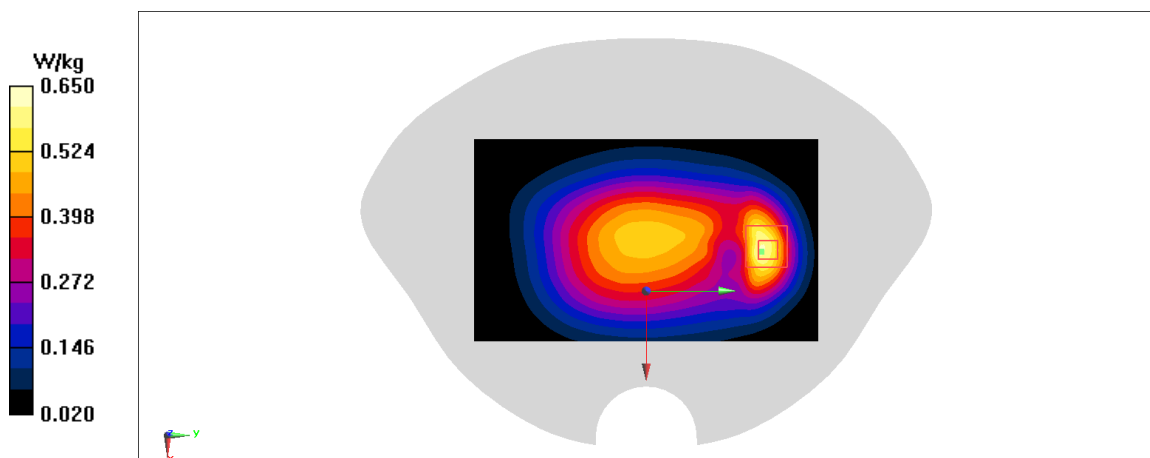

Fig A.12

LTE1900-FDD2_CH19100 Right Cheek

Date: 11/22/2019

Electronics: DAE4 Sn771

Medium: head 1900 MHz

Medium parameters used: $f = 1900$ MHz; $\sigma = 1.39$ mho/m; $\epsilon_r = 39.55$; $\rho = 1000$ kg/m³

Ambient Temperature: 22.5°C, Liquid Temperature: 22.3°C

Communication System: LTE1900-FDD2 1900 MHz Duty Cycle: 1:1

Probe: EX3DV4 – SN3617 ConvF(8.14,8.14,8.14)

Area Scan (71x121x1): Interpolated grid: dx=1.000 mm, dy=1.000 mm

Maximum value of SAR (interpolated) = 0.245 W/kg

Zoom Scan (7x7x7)/Cube 0: Measurement grid: dx=5mm, dy=5mm, dz=5mm

Reference Value = 2.361 V/m; Power Drift = 0.02 dB

Peak SAR (extrapolated) = 0.284 W/kg

SAR(1 g) = 0.178 W/kg; SAR(10 g) = 0.111 W/kg

Maximum value of SAR (measured) = 0.244 W/kg

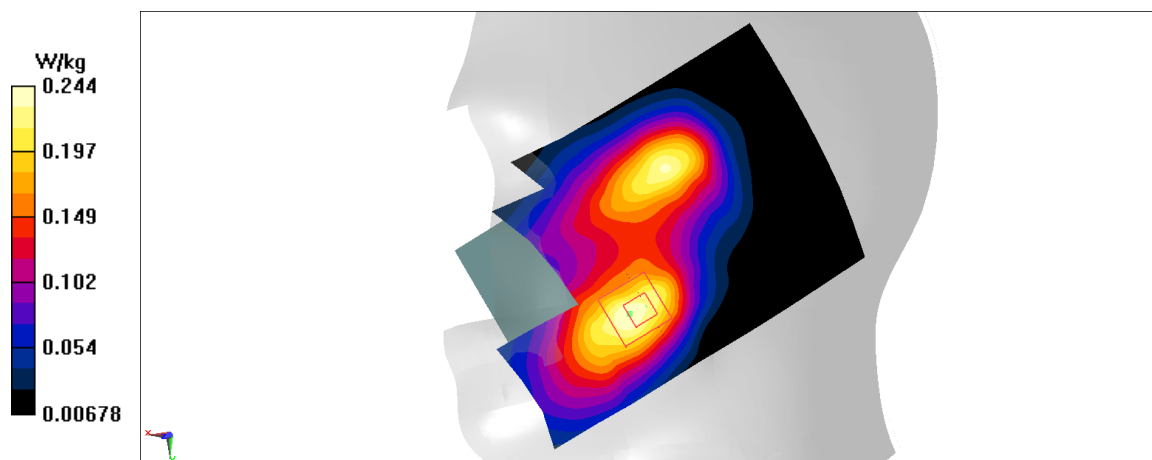

Fig A.13

LTE1900-FDD2_CH19100 Bottom

Date: 11/22/2019

Electronics: DAE4 Sn771

Medium: body 1900 MHz

Medium parameters used: $f = 1900$ MHz; $\sigma = 1.39$ mho/m; $\epsilon_r = 39.55$; $\rho = 1000$ kg/m³

Ambient Temperature: 22.5°C, Liquid Temperature: 22.3°C

Communication System: LTE1900-FDD2 1900 MHz Duty Cycle: 1:1

Probe: EX3DV4 – SN3617 ConvF(7.78,7.78,7.78)

Area Scan (71x121x1): Interpolated grid: dx=1.000 mm, dy=1.000 mm

Maximum value of SAR (interpolated) = 0.585 W/kg

Zoom Scan (7x7x7)/Cube 0: Measurement grid: dx=5mm, dy=5mm, dz=5mm

Reference Value = 15.98 V/m; Power Drift = 0.12 dB

Peak SAR (extrapolated) = 0.722 W/kg

SAR(1 g) = 0.382 W/kg; SAR(10 g) = 0.192 W/kg

Maximum value of SAR (measured) = 0.591 W/kg

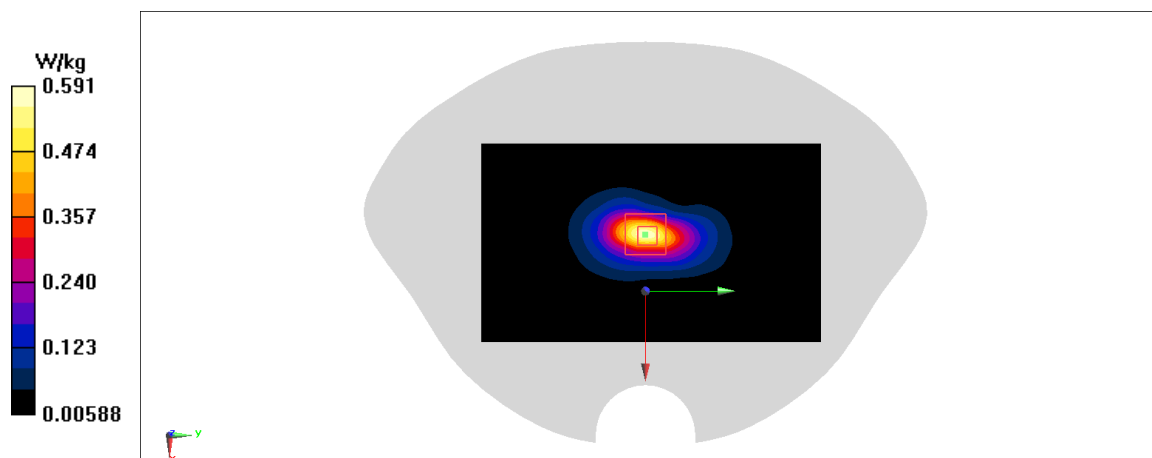
**Fig A.14**

LTE1900-FDD2_CH19100 Rear

Date: 11/22/2019

Electronics: DAE4 Sn771

Medium: body 1900 MHz

Medium parameters used: $f = 1900$ MHz; $\sigma = 1.39$ mho/m; $\epsilon_r = 39.55$; $\rho = 1000$ kg/m³

Ambient Temperature: 22.5°C, Liquid Temperature: 22.3°C

Communication System: LTE1900-FDD2 1900 MHz Duty Cycle: 1:1

Probe: EX3DV4 – SN3617 ConvF(7.78,7.78,7.78)

Area Scan (71x121x1): Interpolated grid: dx=1.000 mm, dy=1.000 mm

Maximum value of SAR (interpolated) = 0.649 W/kg

Zoom Scan (7x7x7)/Cube 0: Measurement grid: dx=5mm, dy=5mm, dz=5mm

Reference Value = 7.931 V/m; Power Drift = -0.01 dB

Peak SAR (extrapolated) = 0.813 W/kg

SAR(1 g) = 0.465 W/kg; SAR(10 g) = 0.268 W/kg

Maximum value of SAR (measured) = 0.676 W/kg

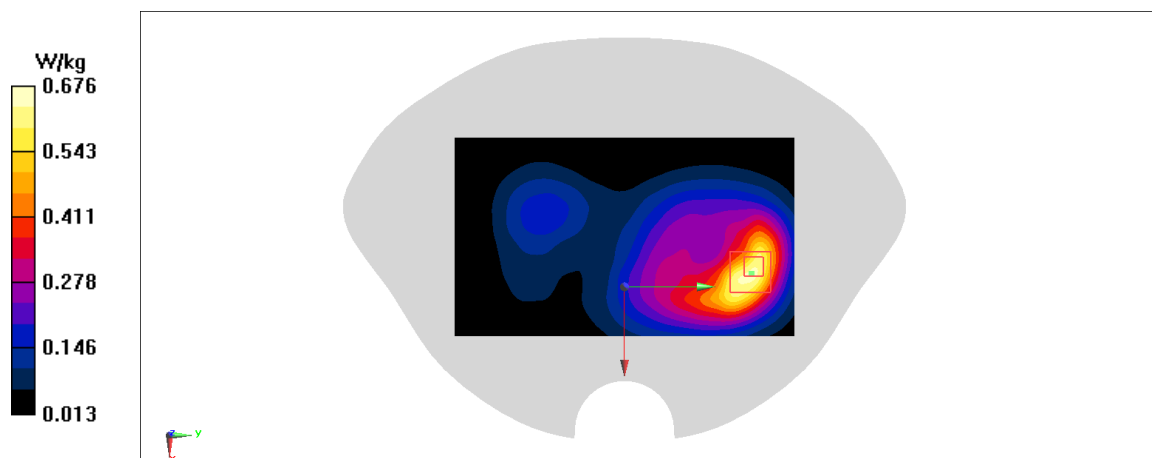

Fig A.15

LTE850-FDD5_CH20450 Left Cheek

Date: 11/20/2019

Electronics: DAE4 Sn771

Medium: head 835 MHz

Medium parameters used: $f = 829$ MHz; $\sigma = 0.895$ mho/m; $\epsilon_r = 41.61$; $\rho = 1000$ kg/m³

Ambient Temperature: 22.5°C, Liquid Temperature: 22.3°C

Communication System: LTE850-FDD5 829 MHz Duty Cycle: 1:1

Probe: EX3DV4 – SN3617 ConvF(9.75,9.75,9.75)

Area Scan (71x121x1): Interpolated grid: dx=1.000 mm, dy=1.000 mm

Maximum value of SAR (interpolated) = 0.358 W/kg

Zoom Scan (7x7x7)/Cube 0: Measurement grid: dx=5mm, dy=5mm, dz=5mm

Reference Value = 3.852 V/m; Power Drift = 0.03 dB

Peak SAR (extrapolated) = 0.404 W/kg

SAR(1 g) = 0.305 W/kg; SAR(10 g) = 0.226 W/kg

Maximum value of SAR (measured) = 0.366 W/kg

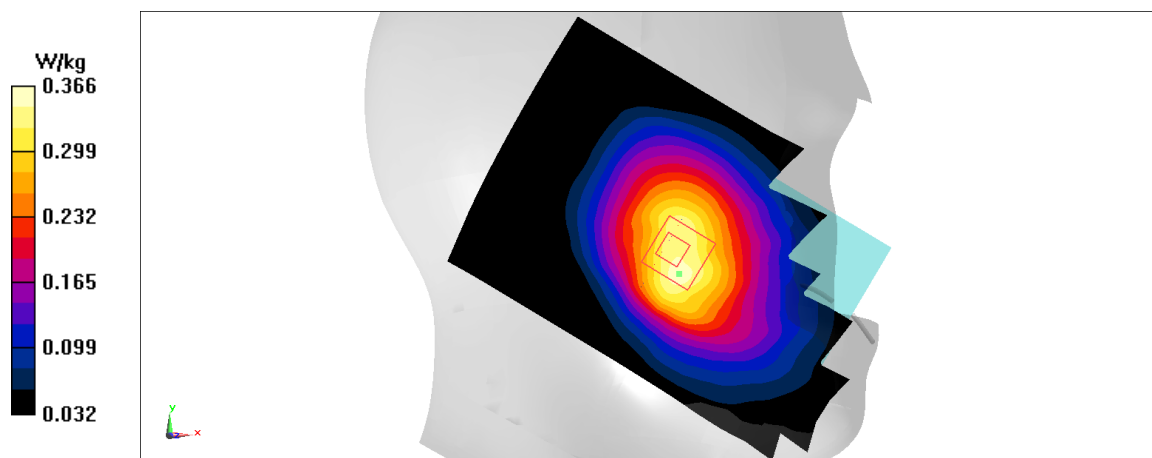

Fig A.16

LTE850-FDD5_CH20450 Rear

Date: 11/20/2019

Electronics: DAE4 Sn771

Medium: body 835 MHz

Medium parameters used: $f = 829$ MHz; $\sigma = 0.895$ mho/m; $\epsilon_r = 41.61$; $\rho = 1000$ kg/m³

Ambient Temperature: 22.5°C, Liquid Temperature: 22.3°C

Communication System: LTE850-FDD5 829 MHz Duty Cycle: 1:1

Probe: EX3DV4 – SN3617 ConvF(9.61,9.61,9.61)

Area Scan (71x121x1): Interpolated grid: dx=1.000 mm, dy=1.000 mm

Maximum value of SAR (interpolated) = 0.511 W/kg

Zoom Scan (7x7x7)/Cube 0: Measurement grid: dx=5mm, dy=5mm, dz=5mm

Reference Value = 22.27 V/m; Power Drift = 0.06 dB

Peak SAR (extrapolated) = 0.561 W/kg

SAR(1 g) = 0.415 W/kg; SAR(10 g) = 0.316 W/kg

Maximum value of SAR (measured) = 0.506 W/kg

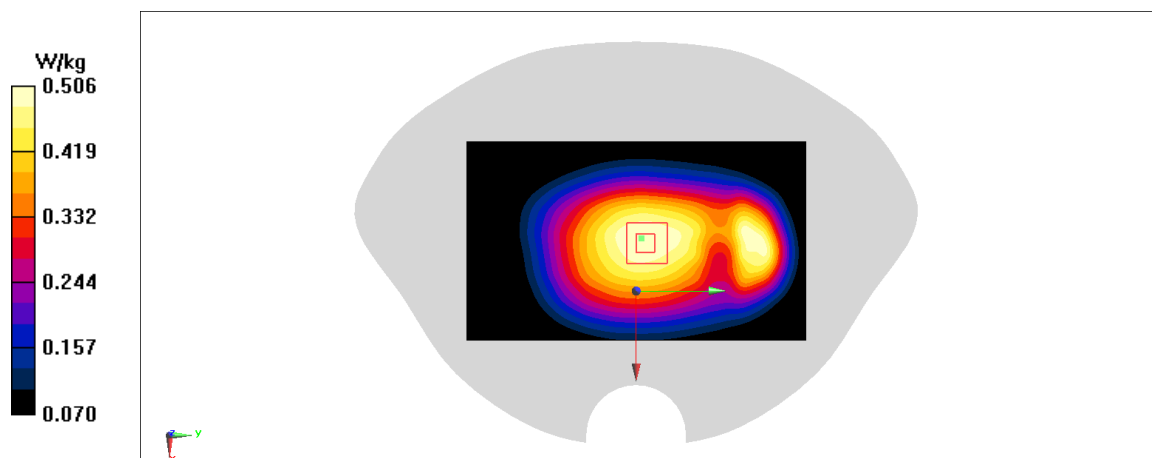

Fig A.17

LTE2500-FDD7_CH21100 Right Cheek

Date: 11/23/2019

Electronics: DAE4 Sn771

Medium: head 2600 MHz

Medium parameters used: $f = 2535$ MHz; $\sigma = 1.904$ mho/m; $\epsilon_r = 39.65$; $\rho = 1000$ kg/m³

Ambient Temperature: 22.5°C, Liquid Temperature: 22.3°C

Communication System: LTE2500-FDD7 2535 MHz Duty Cycle: 1:1

Probe: EX3DV4 – SN3617 ConvF(7.19,7.19,7.19)

Area Scan (71x121x1): Interpolated grid: dx=1.000 mm, dy=1.000 mm

Maximum value of SAR (interpolated) = 0.108 W/kg

Zoom Scan (7x7x7)/Cube 0: Measurement grid: dx=5mm, dy=5mm, dz=5mm

Reference Value = 1.419 V/m; Power Drift = 0.03 dB

Peak SAR (extrapolated) = 0.119 W/kg

SAR(1 g) = 0.0633 W/kg; SAR(10 g) = 0.0319 W/kg

Maximum value of SAR (measured) = 0.0967 W/kg

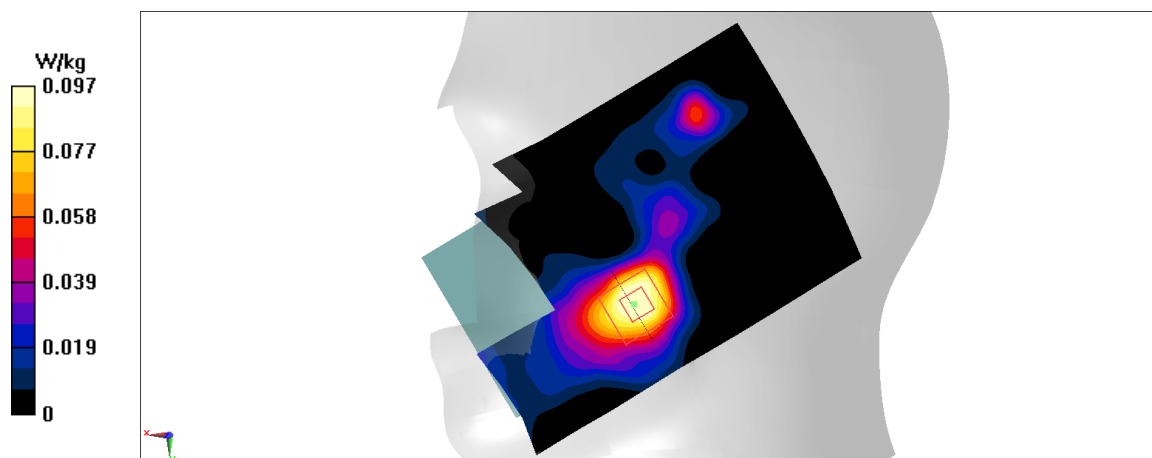

Fig A.18

LTE2500-FDD7_CH21100 Bottom

Date: 11/23/2019

Electronics: DAE4 Sn771

Medium: body 2600 MHz

Medium parameters used: $f = 2535$ MHz; $\sigma = 1.904$ mho/m; $\epsilon_r = 39.65$; $\rho = 1000$ kg/m³

Ambient Temperature: 22.5°C, Liquid Temperature: 22.3°C

Communication System: LTE2500-FDD7 2535 MHz Duty Cycle: 1:1

Probe: EX3DV4 – SN3617 ConvF(7.49,7.49,7.49)

Area Scan (71x121x1): Interpolated grid: dx=1.000 mm, dy=1.000 mm

Maximum value of SAR (interpolated) = 0.869 W/kg

Zoom Scan (7x7x7)/Cube 0: Measurement grid: dx=5mm, dy=5mm, dz=5mm

Reference Value = 14.4 V/m; Power Drift = 0.05 dB

Peak SAR (extrapolated) = 1.06 W/kg

SAR(1 g) = 0.509 W/kg; SAR(10 g) = 0.236 W/kg

Maximum value of SAR (measured) = 0.833 W/kg

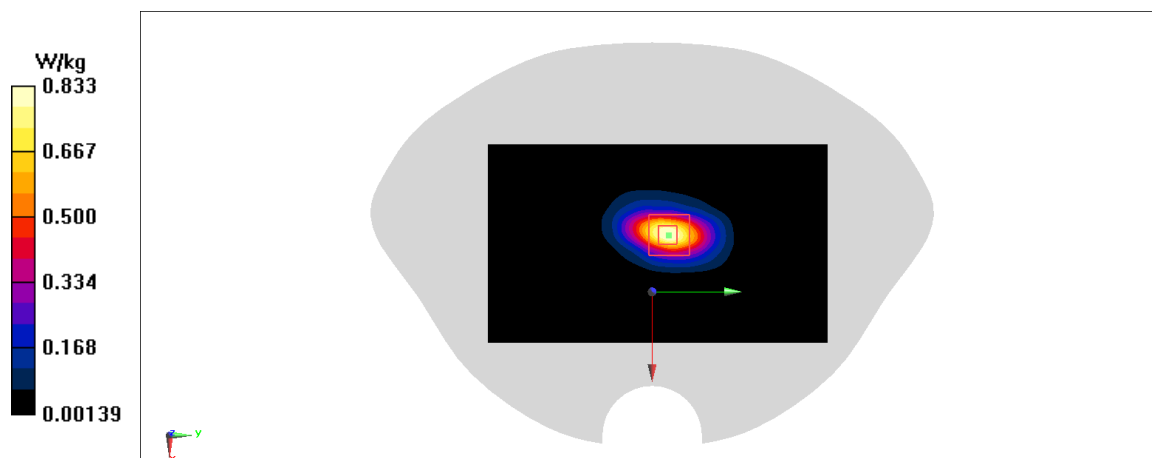
**Fig A.19**

LTE2500-FDD7_CH21350 Rear

Date: 11/23/2019

Electronics: DAE4 Sn771

Medium: body 2600 MHz

Medium parameters used: $f = 2560$ MHz; $\sigma = 1.928$ mho/m; $\epsilon_r = 39.62$; $\rho = 1000$ kg/m³

Ambient Temperature: 22.5°C, Liquid Temperature: 22.3°C

Communication System: LTE2500-FDD7 2560 MHz Duty Cycle: 1:1

Probe: EX3DV4 – SN3617 ConvF(7.49,7.49,7.49)

Area Scan (71x121x1): Interpolated grid: dx=1.000 mm, dy=1.000 mm

Maximum value of SAR (interpolated) = 1.31 W/kg

Zoom Scan (7x7x7)/Cube 0: Measurement grid: dx=5mm, dy=5mm, dz=5mm

Reference Value = 1.921 V/m; Power Drift = 0.05 dB

Peak SAR (extrapolated) = 1.56 W/kg

SAR(1 g) = 0.817 W/kg; SAR(10 g) = 0.419 W/kg

Maximum value of SAR (measured) = 1.28 W/kg

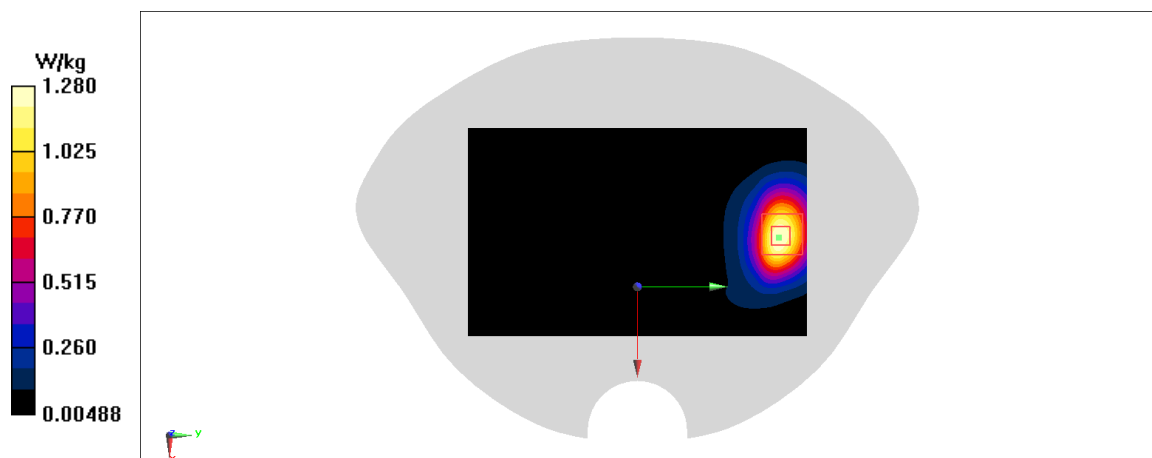
**Fig A.20**

LTE750-FDD13_CH23230 Left Cheek

Date: 11/19/2019

Electronics: DAE4 Sn771

Medium: head 750 MHz

Medium parameters used: $f = 782 \text{ MHz}$; $\sigma = 0.928 \text{ mho/m}$; $\epsilon_r = 41.66$; $\rho = 1000 \text{ kg/m}^3$

Ambient Temperature: 22.5°C, Liquid Temperature: 22.3°C

Communication System: LTE750-FDD13 782 MHz Duty Cycle: 1:1

Probe: EX3DV4 – SN3617 ConvF(10.03,10.03,10.03)

Area Scan (71x121x1): Interpolated grid: $dx=1.000 \text{ mm}$, $dy=1.000 \text{ mm}$

Maximum value of SAR (interpolated) = 0.235 W/kg

Zoom Scan (7x7x7)/Cube 0: Measurement grid: $dx=5\text{mm}$, $dy=5\text{mm}$, $dz=5\text{mm}$

Reference Value = 3.244 V/m; Power Drift = 0.04 dB

Peak SAR (extrapolated) = 0.252 W/kg

SAR(1 g) = 0.195 W/kg; SAR(10 g) = 0.151 W/kg

Maximum value of SAR (measured) = 0.231 W/kg

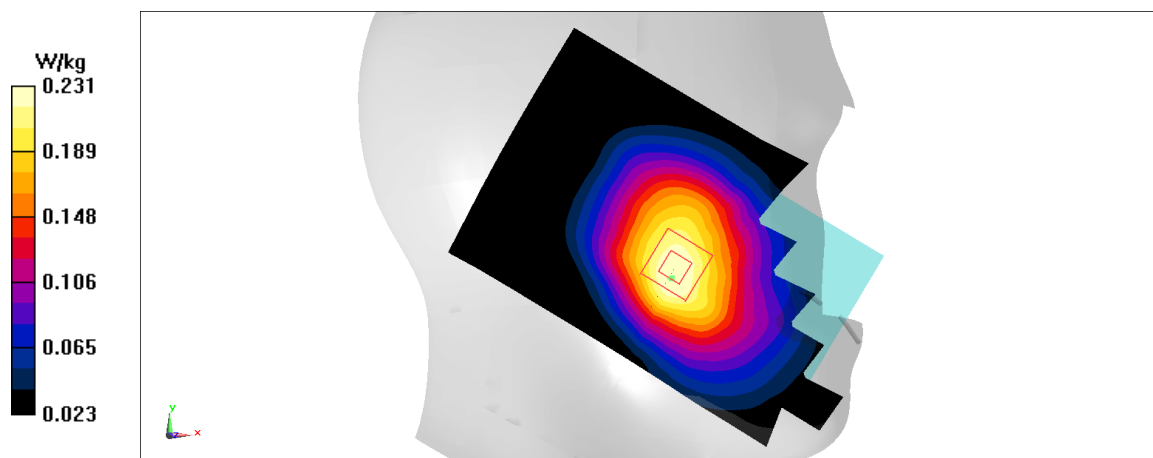

Fig A.21

LTE750-FDD13_CH23230 Rear

Date: 11/19/2019

Electronics: DAE4 Sn771

Medium: body 750 MHz

Medium parameters used: $f = 782 \text{ MHz}$; $\sigma = 0.928 \text{ mho/m}$; $\epsilon_r = 41.66$; $\rho = 1000 \text{ kg/m}^3$ Ambient Temperature: 22.5°C , Liquid Temperature: 22.3°C

Communication System: LTE750-FDD13 782 MHz Duty Cycle: 1:1

Probe: EX3DV4 – SN3617 ConvF(9.85,9.85,9.85)

Area Scan (71x121x1): Interpolated grid: $dx=1.000 \text{ mm}$, $dy=1.000 \text{ mm}$ Maximum value of SAR (interpolated) = 0.376 W/kg **Zoom Scan (7x7x7)/Cube 0:** Measurement grid: $dx=5\text{mm}$, $dy=5\text{mm}$, $dz=5\text{mm}$ Reference Value = 19.15 V/m ; Power Drift = 0.07 dB Peak SAR (extrapolated) = 0.419 W/kg **SAR(1 g) = 0.307 W/kg ; SAR(10 g) = 0.235 W/kg** Maximum value of SAR (measured) = 0.375 W/kg 

Fig A.22

LTE700-FDD17_CH23780 Left Cheek

Date: 11/19/2019

Electronics: DAE4 Sn771

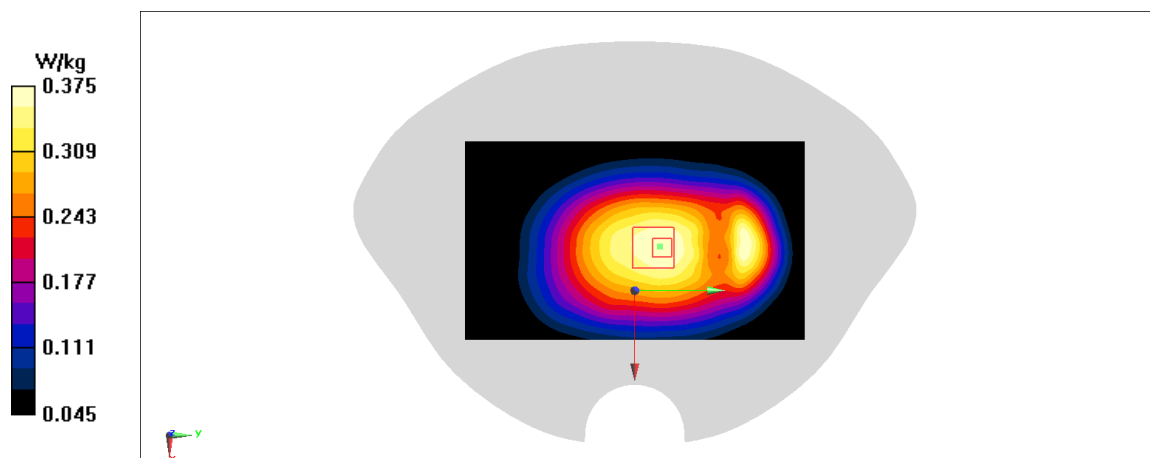
Medium: head 750 MHz

Medium parameters used: $f = 709$ MHz; $\sigma = 0.859$ mho/m; $\epsilon_r = 41.75$; $\rho = 1000$ kg/m³

Ambient Temperature: 22.5°C, Liquid Temperature: 22.3°C

Communication System: LTE700-FDD17 709 MHz Duty Cycle: 1:1

Probe: EX3DV4 – SN3617 ConvF(10.03,10.03,10.03)

Area Scan (71x121x1): Interpolated grid: dx=1.000 mm, dy=1.000 mm

Maximum value of SAR (interpolated) = 0.102 W/kg

Zoom Scan (7x7x7)/Cube 0: Measurement grid: dx=5mm, dy=5mm, dz=5mm

Reference Value = 2.277 V/m; Power Drift = 0.08 dB

Peak SAR (extrapolated) = 0.112 W/kg

SAR(1 g) = 0.0864 W/kg; SAR(10 g) = 0.0666 W/kg

Maximum value of SAR (measured) = 0.103 W/kg

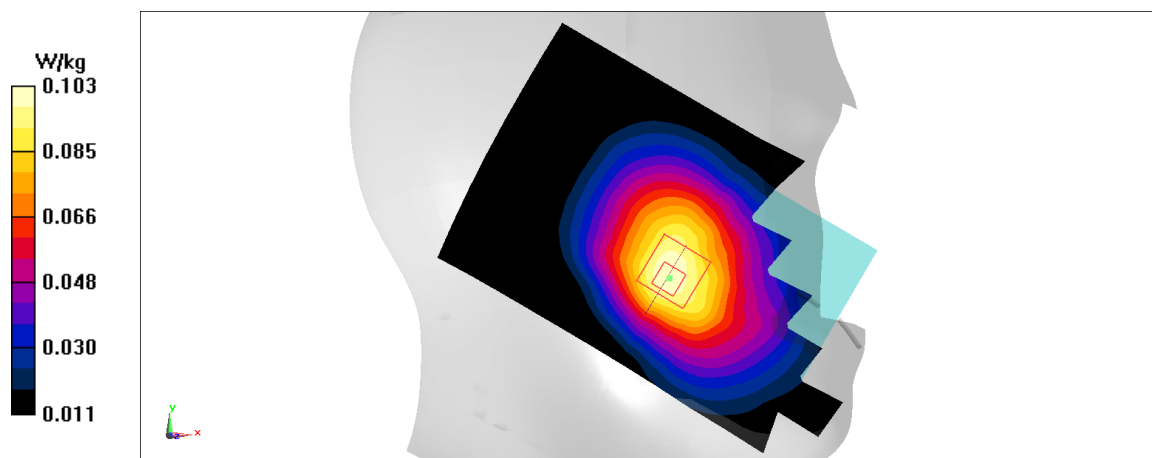

Fig A.23

LTE700-FDD17_CH23780 Rear

Date: 11/19/2019

Electronics: DAE4 Sn771

Medium: body 750 MHz

Medium parameters used: $f = 709$ MHz; $\sigma = 0.859$ mho/m; $\epsilon_r = 41.75$; $\rho = 1000$ kg/m³

Ambient Temperature: 22.5°C, Liquid Temperature: 22.3°C

Communication System: LTE700-FDD17 709 MHz Duty Cycle: 1:1

Probe: EX3DV4 – SN3617 ConvF(9.85,9.85,9.85)

Area Scan (71x121x1): Interpolated grid: dx=1.000 mm, dy=1.000 mm

Maximum value of SAR (interpolated) = 0.171 W/kg

Zoom Scan (7x7x7)/Cube 0: Measurement grid: dx=5mm, dy=5mm, dz=5mm

Reference Value = 11.11 V/m; Power Drift = -0.16 dB

Peak SAR (extrapolated) = 0.197 W/kg

SAR(1 g) = 0.108 W/kg; SAR(10 g) = 0.0676 W/kg

Maximum value of SAR (measured) = 0.155 W/kg

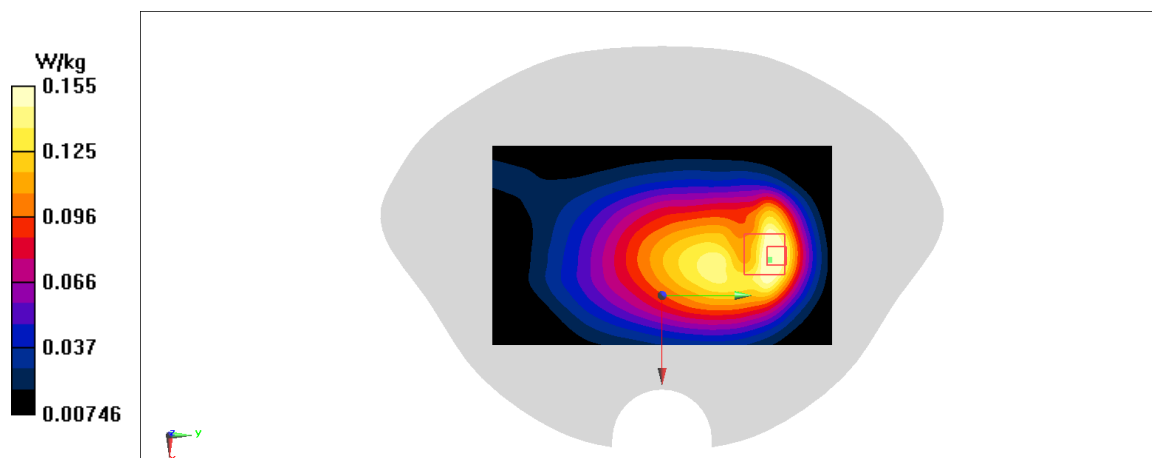

Fig A.24

LTE1700-FDD66_CH132572 Left Cheek

Date: 11/21/2019

Electronics: DAE4 Sn771

Medium: head 1750 MHz

Medium parameters used: $f = 709$ MHz; $\sigma = 0.391$ mho/m; $\epsilon_r = 41.93$; $\rho = 1000$ kg/m³

Ambient Temperature: 22.5°C, Liquid Temperature: 22.3°C

Communication System: LTE1700-FDD66 709 MHz Duty Cycle: 1:1

Probe: EX3DV4 – SN3617 ConvF(8.38,8.38,8.38)

Area Scan (71x121x1): Interpolated grid: dx=1.000 mm, dy=1.000 mm

Maximum value of SAR (interpolated) = 0.34 W/kg

Zoom Scan (7x7x7)/Cube 0: Measurement grid: dx=5mm, dy=5mm, dz=5mm

Reference Value = 4.736 V/m; Power Drift = 0.03 dB

Peak SAR (extrapolated) = 0.417 W/kg

SAR(1 g) = 0.271 W/kg; SAR(10 g) = 0.17 W/kg

Maximum value of SAR (measured) = 0.363 W/kg

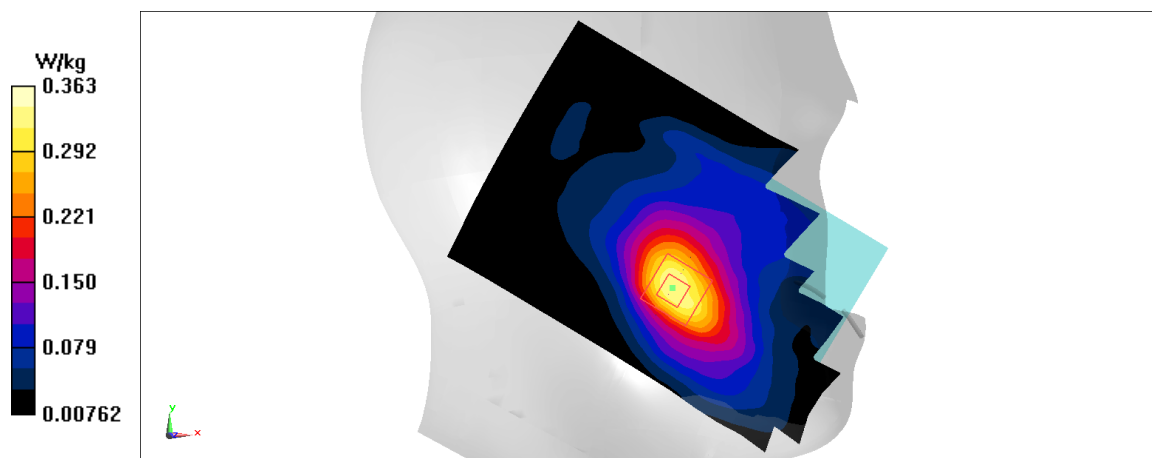

Fig A.25

LTE1700-FDD66_CH132322 Rear

Date: 11/21/2019

Electronics: DAE4 Sn771

Medium: body 1750 MHz

Medium parameters used: $f = 709$ MHz; $\sigma = 0.391$ mho/m; $\epsilon_r = 41.93$; $\rho = 1000$ kg/m³

Ambient Temperature: 22.5°C, Liquid Temperature: 22.3°C

Communication System: LTE1700-FDD66 709 MHz Duty Cycle: 1:1

Probe: EX3DV4 – SN3617 ConvF(8.03,8.03,8.03)

Area Scan (71x121x1): Interpolated grid: dx=1.000 mm, dy=1.000 mm

Maximum value of SAR (interpolated) = 0.398 W/kg

Zoom Scan (7x7x7)/Cube 0: Measurement grid: dx=5mm, dy=5mm, dz=5mm

Reference Value = 6.203 V/m; Power Drift = -0.03 dB

Peak SAR (extrapolated) = 0.535 W/kg

SAR(1 g) = 0.287 W/kg; SAR(10 g) = 0.154 W/kg

Maximum value of SAR (measured) = 0.433 W/kg

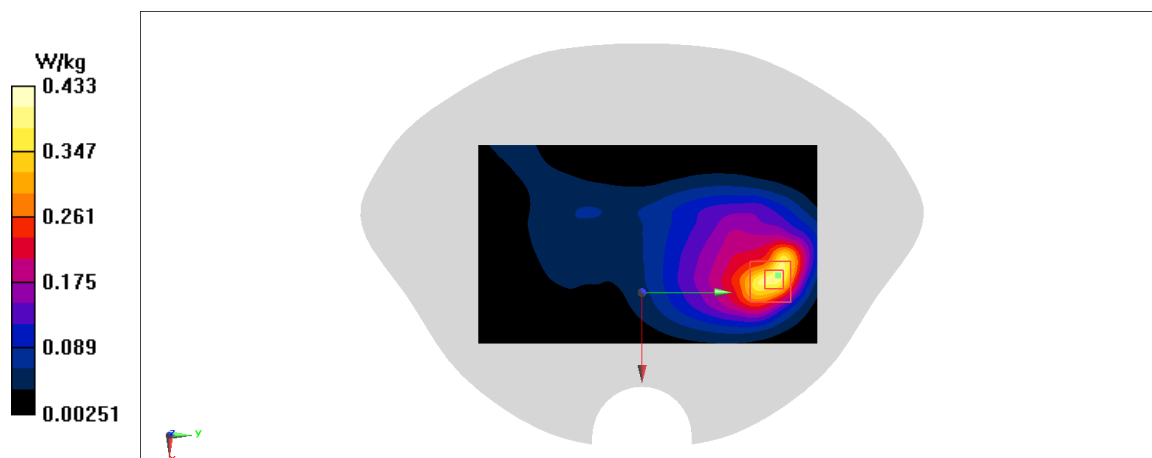

Fig A.26

LTE1700-FDD66_CH132572 Rear

Date: 11/21/2019

Electronics: DAE4 Sn771

Medium: body 1750 MHz

Medium parameters used: $f = 709$ MHz; $\sigma = 0.391$ mho/m; $\epsilon_r = 41.93$; $\rho = 1000$ kg/m³

Ambient Temperature: 22.5°C, Liquid Temperature: 22.3°C

Communication System: LTE1700-FDD66 709 MHz Duty Cycle: 1:1

Probe: EX3DV4 – SN3617 ConvF(8.03,8.03,8.03)

Area Scan (71x121x1): Interpolated grid: dx=1.000 mm, dy=1.000 mm

Maximum value of SAR (interpolated) = 0.616 W/kg

Zoom Scan (7x7x7)/Cube 0: Measurement grid: dx=5mm, dy=5mm, dz=5mm

Reference Value = 7.335 V/m; Power Drift = -0.14 dB

Peak SAR (extrapolated) = 0.735 W/kg

SAR(1 g) = 0.421 W/kg; SAR(10 g) = 0.245 W/kg

Maximum value of SAR (measured) = 0.611 W/kg

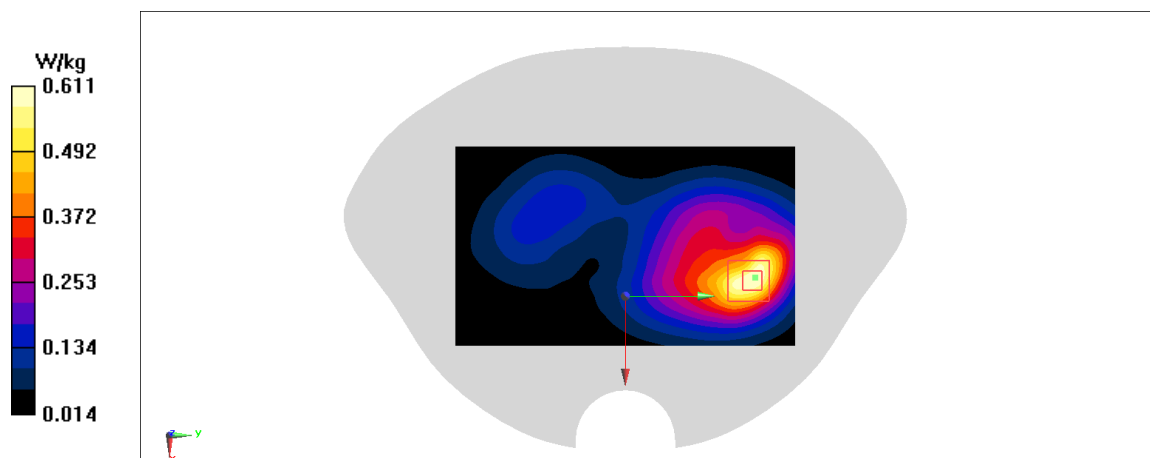

Fig A.27

WLAN2450_CH6 Right Tilt

Date: 11/23/2019

Electronics: DAE4 Sn771

Medium: head 2450 MHz

Medium parameters used: $f = 2437$; $\sigma = 1.772$ mho/m; $\epsilon_r = 39.07$; $\rho = 1000$ kg/m³

Ambient Temperature: 22.5°C, Liquid Temperature: 22.3°C

Communication System: WLAN2450 2437 Duty Cycle: 1:1

Probe: EX3DV4 – SN3617 ConvF(7.62,7.62,7.62)

Area Scan (71x121x1): Interpolated grid: dx=1.000 mm, dy=1.000 mm

Maximum value of SAR (interpolated) = 0.777 W/kg

Zoom Scan (7x7x7)/Cube 0: Measurement grid: dx=5mm, dy=5mm, dz=5mm

Reference Value = 8.346 V/m; Power Drift = 0.09 dB

Peak SAR (extrapolated) = 0.933 W/kg

SAR(1 g) = 0.412 W/kg; SAR(10 g) = 0.162 W/kg

Maximum value of SAR (measured) = 0.693 W/kg

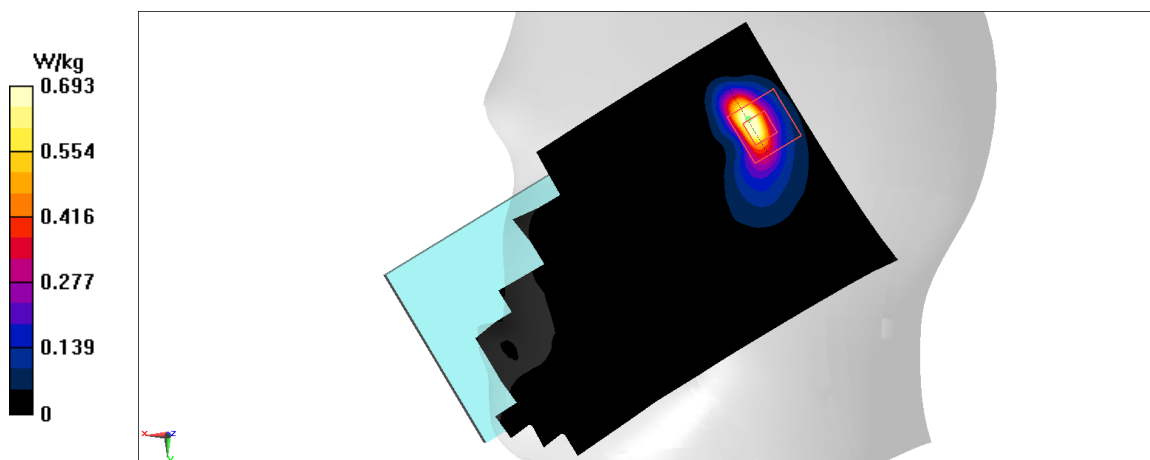

Fig A.28

WLAN2450_CH6 Top

Date: 11/23/2019

Electronics: DAE4 Sn771

Medium: body 2450 MHz

Medium parameters used: $f = 2437$; $\sigma = 1.772$ mho/m; $\epsilon_r = 39.07$; $\rho = 1000$ kg/m³

Ambient Temperature: 22.5°C, Liquid Temperature: 22.3°C

Communication System: WLAN2450 2437 Duty Cycle: 1:1

Probe: EX3DV4 – SN3617 ConvF(7.79,7.79,7.79)

Area Scan (71x121x1): Interpolated grid: dx=1.000 mm, dy=1.000 mm

Maximum value of SAR (interpolated) = 0.345 W/kg

Zoom Scan (7x7x7)/Cube 0: Measurement grid: dx=5mm, dy=5mm, dz=5mm

Reference Value = 7.669 V/m; Power Drift = 0.03 dB

Peak SAR (extrapolated) = 0.411 W/kg

SAR(1 g) = 0.198 W/kg; SAR(10 g) = 0.0894 W/kg

Maximum value of SAR (measured) = 0.331 W/kg

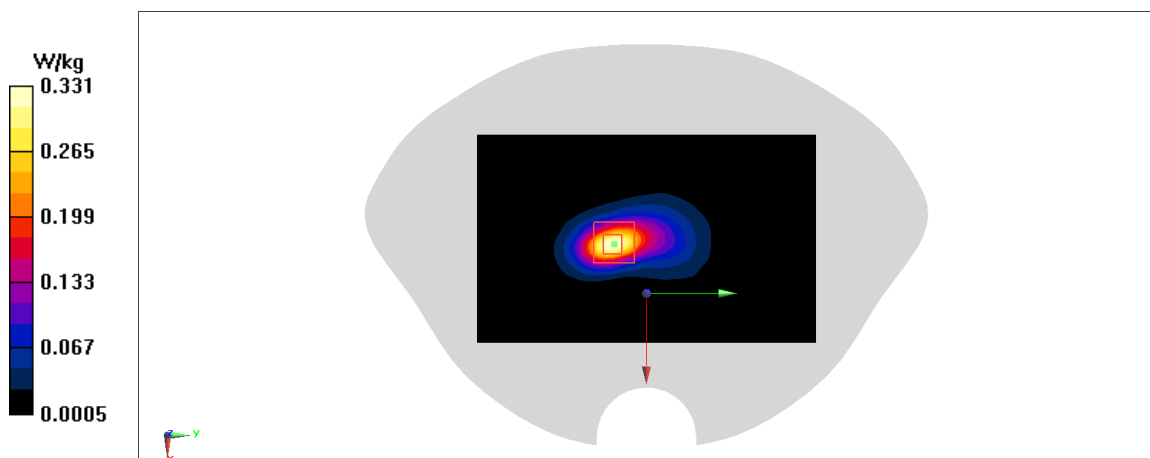

Fig A.29

LTE700-FDD28_CH27460 Left Cheek

Date: 11/19/2019

Electronics: DAE4 Sn771

Medium: head 750 MHz

Medium parameters used: $f = 728 \text{ MHz}$; $\sigma = 0.898 \text{ mho/m}$; $\epsilon_r = 41.7$; $\rho = 1000 \text{ kg/m}^3$

Ambient Temperature: 22.5°C , Liquid Temperature: 22.3°C

Communication System: LTE700-FDD28 728 MHz Duty Cycle: 1:1

Probe: EX3DV4 – SN3617 ConvF(10.03,10.03,10.03)

Area Scan (71x121x1): Interpolated grid: $dx=1.000 \text{ mm}$, $dy=1.000 \text{ mm}$

Maximum value of SAR (interpolated) = 0.143 W/kg

Zoom Scan (7x7x7)/Cube 0: Measurement grid: $dx=5\text{mm}$, $dy=5\text{mm}$, $dz=5\text{mm}$

Reference Value = 2.585 V/m ; Power Drift = 0.01 dB

Peak SAR (extrapolated) = 0.152 W/kg

SAR(1 g) = 0.123 W/kg ; SAR(10 g) = 0.097 W/kg

Maximum value of SAR (measured) = 0.141 W/kg

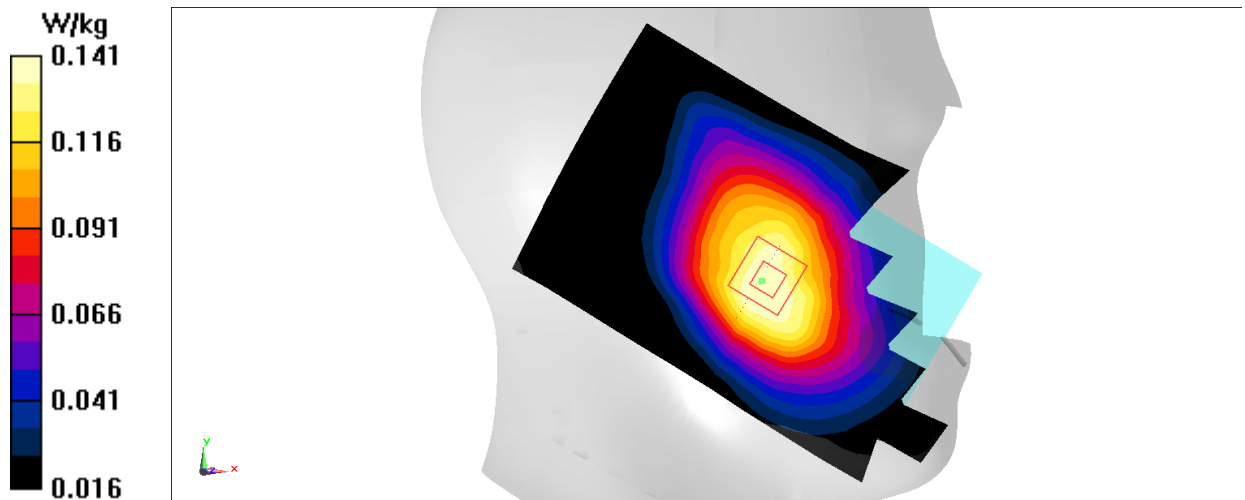

Fig A.30

LTE700-FDD28_CH27460 Rear

Date: 11/19/2019

Electronics: DAE4 Sn771

Medium: body 750 MHz

Medium parameters used: $f = 728$ MHz; $\sigma = 0.898$ mho/m; $\epsilon_r = 41.7$; $\rho = 1000$ kg/m³

Ambient Temperature: 22.5°C, Liquid Temperature: 22.3°C

Communication System: LTE700-FDD28 728 MHz Duty Cycle: 1:1

Probe: EX3DV4 – SN3617 ConvF(9.85,9.85,9.85)

Area Scan (71x121x1): Interpolated grid: dx=1.000 mm, dy=1.000 mm

Maximum value of SAR (interpolated) = 0.248 W/kg

Zoom Scan (7x7x7)/Cube 0: Measurement grid: dx=5mm, dy=5mm, dz=5mm

Reference Value = 15.40 V/m; Power Drift = 0.07 dB

Peak SAR (extrapolated) = 0.307 W/kg

SAR(1 g) = 0.202 W/kg; SAR(10 g) = 0.153 W/kg

Maximum value of SAR (measured) = 0.249 W/kg

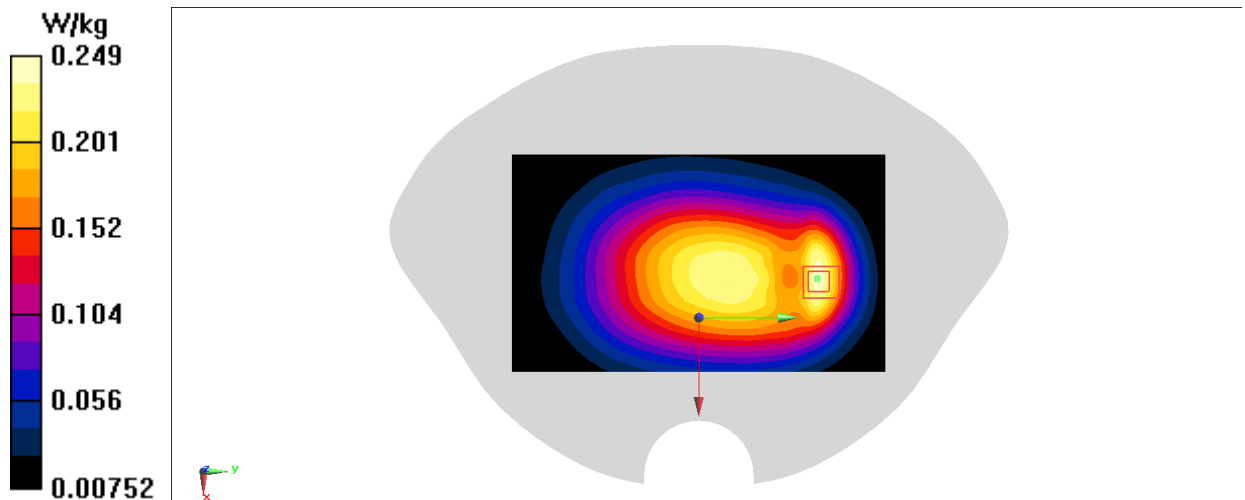

Fig A.31

I.6 ANNEX SYSTEM VALIDATION RESULTS

750 MHz

Date: 11/19/2019

Electronics: DAE4 Sn771

Medium: Head 750 MHz

Medium parameters used: $f = 750 \text{ MHz}$; $\sigma = 0.898 \text{ mho/m}$; $\epsilon_r = 41.7$; $\rho = 1000 \text{ kg/m}^3$

Ambient Temperature: 22.5°C Liquid Temperature: 22.3°C

Communication System: CW Frequency: 750 MHz Duty Cycle: 1:1

Probe: EX3DV4 – SN3617 ConvF(10.03,10.03,10.03)

System Validation /Area Scan (81x191x1): Interpolated grid: $dx=1.000 \text{ mm}$, $dy=1.000 \text{ mm}$

Reference Value = 60.78 V/m ; Power Drift = 0.03

Fast SAR: SAR(1 g) = 2.11 W/kg; SAR(10 g) = 1.42 W/kg

Maximum value of SAR (interpolated) = 2.78 W/kg

System Validation /Zoom Scan (7x7x7)/Cube 0: Measurement grid: $dx=5\text{mm}$, $dy=5\text{mm}$, $dz=5\text{mm}$

Reference Value = 60.78 V/m ; Power Drift = 0.03 dB

Peak SAR (extrapolated) = 3.16 W/kg

SAR(1 g) = 2.14 W/kg; SAR(10 g) = 1.38 W/kg

Maximum value of SAR (measured) = 2.83 W/kg

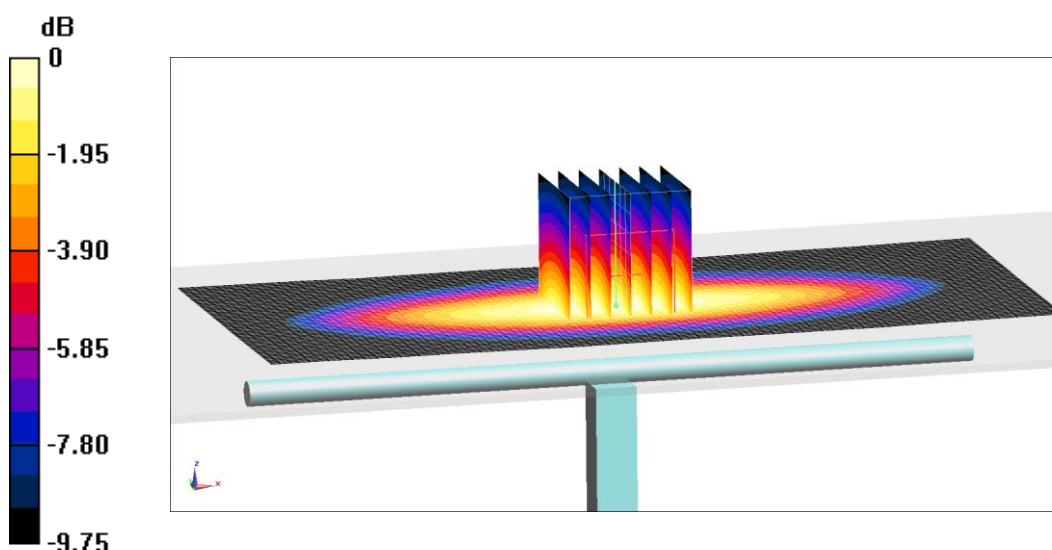

0 dB = $2.83 \text{ W/kg} = 4.52 \text{ dB W/kg}$

Fig.B.1 validation 750 MHz 250mW

835 MHz

Date: 11/20/2019

Electronics: DAE4 Sn771

Medium: Head 835 MHz

Medium parameters used: $f = 835 \text{ MHz}$; $\sigma = 0.901 \text{ mho/m}$; $\epsilon_r = 41.6$; $\rho = 1000 \text{ kg/m}^3$

Ambient Temperature: 22.5°C Liquid Temperature: 22.3°C

Communication System: CW Frequency: 835 MHz Duty Cycle: 1:1

Probe: EX3DV4 – SN3617 ConvF(9.75,9.75,9.75)

System Validation /Area Scan (81x191x1): Interpolated grid: $dx=1.000 \text{ mm}$, $dy=1.000 \text{ mm}$

Reference Value = 63.88 V/m; Power Drift = 0.04

Fast SAR: SAR(1 g) = 2.42 W/kg; SAR(10 g) = 1.56 W/kg

Maximum value of SAR (interpolated) = 3.16 W/kg

System Validation /Zoom Scan (7x7x7)/Cube 0: Measurement grid: $dx=5\text{mm}$, $dy=5\text{mm}$, $dz=5\text{mm}$

Reference Value = 63.88 V/m; Power Drift = 0.04 dB

Peak SAR (extrapolated) = 3.62 W/kg

SAR(1 g) = 2.45 W/kg; SAR(10 g) = 1.57 W/kg

Maximum value of SAR (measured) = 3.26 W/kg

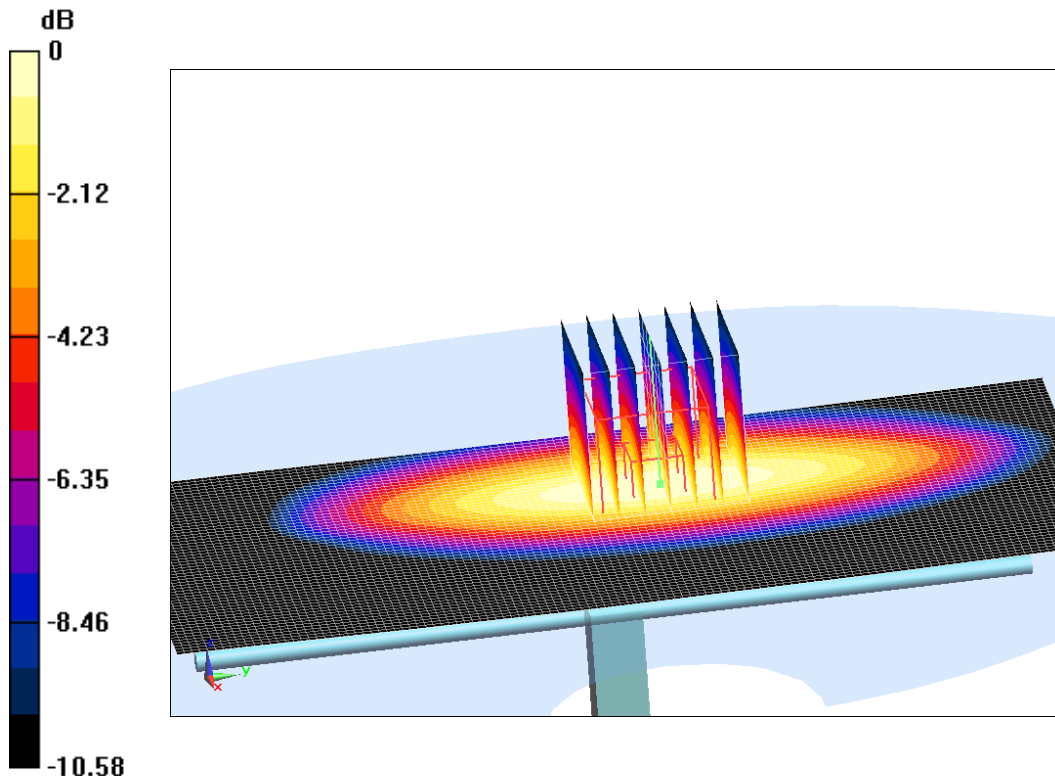

0 dB = 3.26 W/kg = 5.13 dB W/kg

Fig.B.2 validation 835 MHz 250mW

1750 MHz

Date: 11/21/2019

Electronics: DAE4 Sn771

Medium: Head 1750 MHz

Medium parameters used: $f = 1750$ MHz; $\sigma = 1.38$ mho/m; $\epsilon_r = 40.68$; $\rho = 1000$ kg/m³

Ambient Temperature: 22.5°C Liquid Temperature: 22.3°C

Communication System: CW Frequency: 1750 MHz Duty Cycle: 1:1

Probe: EX3DV4 – SN3617 ConvF(8.38,8.38,8.38)

System Validation /Area Scan (81x191x1): Interpolated grid: dx=1.000 mm, dy=1.000 mm

Reference Value = 104.5 V/m; Power Drift = 0.06

Fast SAR: SAR(1 g) = 9.03 W/kg; SAR(10 g) = 4.83 W/kg

Maximum value of SAR (interpolated) = 14.31 W/kg

System Validation /Zoom Scan (7x7x7)/Cube 0: Measurement grid: dx=5mm, dy=5mm, dz=5mm

Reference Value = 104.5 V/m; Power Drift = 0.06 dB

Peak SAR (extrapolated) = 16.53 W/kg

SAR(1 g) = 9.01 W/kg; SAR(10 g) = 4.85 W/kg

Maximum value of SAR (measured) = 13.9 W/kg

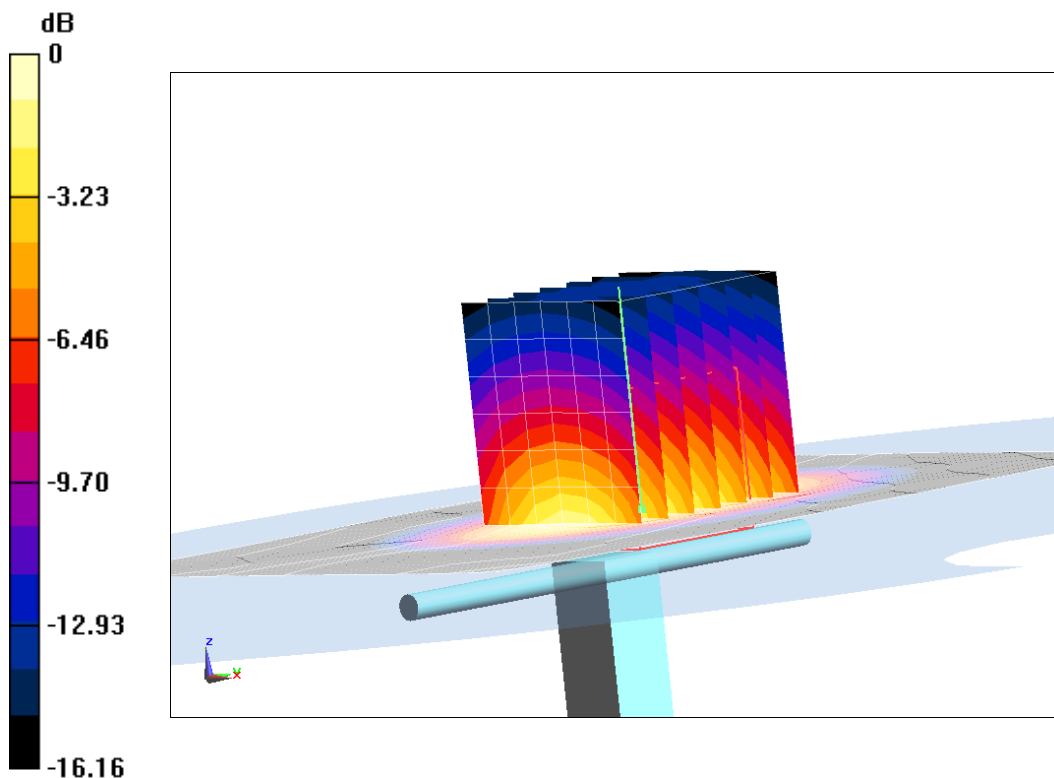

0 dB = 13.9 W/kg = 11.43 dB W/kg

Fig.B.3 validation 1750 MHz 250mW