

13 SAR Test Result

The calculated SAR is obtained by the following formula:

$$\text{Reported SAR} = \text{Measured SAR} \times 10^{(P_{\text{Target}} - P_{\text{Measured}})/10}$$

Where P_{Target} is the power of manufacturing upper limit;

P_{Measured} is the measured power in chapter 10.

Duty Cycle

Mode	Duty Cycle
GPGS 850/1900 (Normal Power)	1:4
GPGS 850/1900 (Sensor on)	1:2
WCDMA B2/B4/B5	1.1
LTE Band 2/5/7/12/66/71	1:1

13.1 SAR results

Table 13.1: SAR Values (GSM 850 -Body)

Frequency		Test Mode	Test Position	Figure No.	Conducted Power (dBm)	Max. tune-up Power (dBm)	Measured SAR(1g) (W/kg)	Reported SAR(1g) (W/kg)	Power Drift(dB)
MHz	Ch.								
Ambient Temperature: 22.5°C Liquid Temperature: 22.0°C									
Test Data (0mm)									
836.6	190	GPRS	Rear	/	22.96	24	0.539	0.68	0.14
836.6	190	GPRS	Right	/	22.96	24	0.193	0.25	0.05
836.6	190	GPRS	Top	/	22.96	24	0.531	0.67	0.10
848.8	251	GPRS	Rear	/	23.03	24	0.458	0.57	0.05
824.2	128	GPRS	Rear	Fig.1	22.68	24	0.668	0.91	0.13
Test Data (14mm)									
836.6	190	GPRS	Right	/	31.04	32	0.153	0.19	0.04
836.6	190	GPRS	Top	/	31.04	32	0.345	0.43	0.01
Test Data (15mm)									
836.6	190	GPRS	Rear	/	31.04	32	0.501	0.62	0.02
848.8	251	GPRS	Rear	/	31.01	32	0.474	0.60	-0.02
824.2	128	GPRS	Rear	/	30.91	32	0.484	0.62	0.02

Table 13.2: SAR Values (GSM 1900 - Body)

Frequency		Test Mode	Test Position	Figure No.	Conducted Power (dBm)	Max. tune-up Power (dBm)	Measured SAR(1g) (W/kg)	Reported SAR(1g) (W/kg)	Power Drift(dB)
MHz	Ch.								
Ambient Temperature: 22.8°C Liquid Temperature: 22.3°C									
Test Data (0mm)									
1880	661	GPRS	Rear	/	16.41	17.5	0.910	1.17	0.03
1880	661	GPRS	Right	/	16.41	17.5	0.080	0.10	0.02
1880	661	GPRS	Top	/	16.41	17.5	0.513	0.66	0.09
1909.8	810	GPRS	Rear	Fig.2	16.50	17.5	0.945	1.19	0.07
1850.2	512	GPRS	Rear	/	16.43	17.5	0.875	1.12	-0.01
Test Data (14mm)									
1880	661	GPRS	Right	/	28.24	29.5	0.111	0.15	-0.10
1880	661	GPRS	Top	/	28.24	29.5	0.516	0.69	0.08
1909.8	810	GPRS	Top	/	28.33	29.5	0.609	0.80	0.04
1850.2	512	GPRS	Top	/	28.31	29.5	0.438	0.58	0.11
Test Data (15mm)									
1880	661	GPRS	Rear	/	28.24	29.5	0.491	0.66	-0.03

Table 13.3: SAR Values (WCDMA 850 -Body)

Frequency		Test Mode	Test Position	Figure No.	Conducted Power (dBm)	Max. tune-up Power (dBm)	Measured SAR(1g) (W/kg)	Reported SAR(1g) (W/kg)	Power Drift(dB)
MHz	Ch.								
Ambient Temperature: 22.5°C Liquid Temperature: 22.0°C									
Test Data (0mm)									
836.4	4182	RMC	Rear	Fig.3	23.40	24	1.160	1.33	0.11
836.4	4182	RMC	Right	/	23.40	24	0.660	0.76	0.04
836.4	4182	RMC	Top	/	23.40	24	0.865	0.99	0.12
846.6	4233	RMC	Rear	/	23.38	24	1.130	1.30	0.01
826.4	4132	RMC	Rear	/	23.36	24	1.150	1.33	0.04
846.6	4233	RMC	Top	/	23.38	24	0.878	1.01	0.09
826.4	4132	RMC	Top	/	23.36	24	0.854	0.99	0.09

Table 13.4: SAR Values (WCDMA1900 - Body)

Frequency		Test Mode	Test Position	Figure No.	Conducted Power (dBm)	Max. tune-up Power (dBm)	Measured SAR(1g) (W/kg)	Reported SAR(1g) (W/kg)	Power Drift(dB)
MHz	Ch.								
Ambient Temperature: 22.8°C Liquid Temperature: 22.3°C									
Test Data (0mm)									
1880	9400	RMC	Rear	/	12.78	13	1.160	1.22	0.04
1880	9400	RMC	Right	/	12.78	13	0.092	0.10	0.03
1880	9400	RMC	Top	/	12.78	13	0.487	0.51	-0.02
1907.6	9538	RMC	Rear	Fig.4	12.69	13	1.230	1.32	0.04
1852.4	9262	RMC	Rear	/	12.87	13	1.100	1.13	0.05
Test Data (14mm)									
1880	9400	RMC	Right	/	23.45	24	0.281	0.32	-0.04
1880	9400	RMC	Top	/	23.45	24	0.869	0.99	-0.05
1907.6	9538	RMC	Top	/	23.41	24	1.060	1.21	0.02
1852.4	9262	RMC	Top	/	23.49	24	0.779	0.88	0.05
Test Data (15mm)									
1880	9400	RMC	Rear	/	23.45	24	0.733	0.83	0.11
1907.6	9538	RMC	Rear	/	23.41	24	0.867	0.99	0.03
1852.4	9262	RMC	Rear	/	23.49	24	0.776	0.87	0.03

Table 13.5: SAR Values (WCDMA 1700 - Body)

Frequency		Test Mode	Test Position	Figure No.	Conducted Power (dBm)	Max. tune-up Power (dBm)	Measured SAR(1g) (W/kg)	Reported SAR(1g) (W/kg)	Power Drift(dB)
MHz	Ch.								
Ambient Temperature: 22.4°C Liquid Temperature: 21.9°C									
Test Data (0mm)									
1732.6	1413	RMC	Rear	/	13.34	15	0.524	0.78	0.09
1732.6	1413	RMC	Right	/	13.34	15	0.073	0.11	0.08
1732.6	1413	RMC	Top	/	13.34	15	0.294	0.44	0.04
1752.6	1513	RMC	Rear	Fig.5	13.32	15	0.785	1.16	0.02
1712.4	1312	RMC	Rear	/	13.31	15	0.452	0.67	0.01
Test Data (14mm)									
1732.6	1413	RMC	Right	/	23.42	24	0.215	0.25	0.08
1732.6	1413	RMC	Top	/	23.42	24	0.388	0.44	0.06
1752.6	1513	RMC	Top	/	23.44	24	0.485	0.55	0.01
1712.4	1312	RMC	Top	/	23.32	24	0.300	0.35	0.03
Test Data (15mm)									
1732.6	1413	RMC	Rear	/	23.42	24	0.382	0.53	0.00

Table 13.6: SAR Values (LTE Band 2 - Body)

Frequency		Test Mode	Test Position	Figure No.	Conducted Power (dBm)	Max. tune-up Power (dBm)	Measured SAR(1g) (W/kg)	Reported SAR(1g) (W/kg)	Power Drift(dB)
MHz	Ch.								
Ambient Temperature: 22.8°C					Liquid Temperature: 22.3°C				
Test Data (0mm)									
1880	18900	1RB_Mid	Rear	/	12.38	13.5	0.899	1.16	0.04
1880	18900	50RB_Low	Rear	/	12.37	13.5	0.919	1.19	0.04
1880	18900	1RB_Mid	Right	/	12.38	13.5	0.073	0.09	-0.01
1880	18900	50RB_Low	Right	/	12.37	13.5	0.077	0.10	-0.09
1880	18900	1RB_Mid	Top	/	12.38	13.5	0.346	0.45	0.09
1880	18900	50RB_Low	Top	/	12.37	13.5	0.416	0.54	0.12
1900	19100	1RB_Mid	Rear	Fig.6	12.24	13.5	0.942	1.26	0.04
1860	18700	1RB_Mid	Rear	/	12.32	13.5	0.859	1.13	0.02
1900	19100	50RB_Mid	Rear	/	12.14	13.5	0.915	1.25	0.15
1860	18700	50RB_Low	Rear	/	12.28	13.5	0.836	1.11	0.01
1880	18900	100RB	Rear	/	12.32	13.5	0.903	1.18	-0.08
Test Data (14mm)									
1880	18900	1RB_Mid	Right	/	23.33	24	0.229	0.27	0.01
1880	18900	50RB_Low	Right	/	22.42	23	0.206	0.24	0.05
1880	18900	1RB_Mid	Top	/	23.33	24	0.828	0.97	-0.02
1880	18900	50RB_Low	Top	/	22.42	23	0.670	0.77	-0.07
1900	19100	1RB_Mid	Top	/	23.23	24	0.947	1.13	-0.10
1860	18700	1RB_Mid	Top	/	23.4	24	0.742	0.85	-0.03
1880	18900	100RB	Top	/	22.44	23	0.875	1.00	-0.11
Test Data (15mm)									
1880	18900	1RB_Mid	Rear	/	23.33	24	0.815	0.95	0.05
1880	18900	50RB_Low	Rear	/	22.42	23	0.688	0.79	-0.04
1900	19100	1RB_Mid	Rear	/	23.23	24	0.852	1.02	0.03
1860	18700	1RB_Mid	Rear	/	23.4	24	0.787	0.90	0.10
1880	18900	100RB	Rear	/	22.44	23	0.641	0.73	0.01

Table 13.7: SAR Values (LTE Band 5 - Body)

Frequency		Test Mode	Test Position	Figure No.	Conducted Power (dBm)	Max. tune-up Power (dBm)	Measured SAR(1g) (W/kg)	Reported SAR(1g) (W/kg)	Power Drift(dB)
MHz	Ch.								
Ambient Temperature: 22.5°C Liquid Temperature: 22.0°C									
Test Data (0mm)									
836.5	20525	1RB_Mid	Rear	/	17.38	19	0.424	0.62	0.06
836.5	20525	25RB_Mid	Rear	/	17.29	19	0.377	0.56	-0.02
836.5	20525	1RB_Mid	Right	/	17.38	19	0.183	0.27	0.03
836.5	20525	25RB_Mid	Right	/	17.29	19	0.177	0.26	0.03
836.5	20525	1RB_Mid	Top	/	17.38	19	0.337	0.49	-0.09
836.5	20525	25RB_Mid	Top	/	17.29	19	0.341	0.51	-0.05
844	20600	1RB_Mid	Rear	/	17.35	19	0.432	0.63	0.08
829	20450	1RB_Mid	Rear	Fig.7	17.32	19	0.452	0.67	0.06
Test Data (14mm)									
836.5	20525	1RB_Mid	Right	/	23.34	24	0.124	0.14	0.03
836.5	20525	25RB_High	Right	/	22.31	23	0.065	0.08	0.09
836.5	20525	1RB_Mid	Top	/	23.34	24	0.327	0.38	0.03
836.5	20525	25RB_High	Top	/	22.31	23	0.258	0.30	0.01
Test Data (15mm)									
836.5	20525	1RB_Mid	Rear	/	23.34	24	0.363	0.42	0.04
836.5	20525	25RB_High	Rear	/	22.31	23	0.287	0.34	0.05
844	20600	1RB_Mid	Rear	/	23.35	24	0.352	0.41	0.06
829	20450	1RB_Mid	Rear	/	23.45	24	0.365	0.41	0.06

Table 13.8: SAR Values (LTE Band 7 - Body)

Frequency		Test Mode	Test Position	Figure No.	Conducted Power (dBm)	Max. tune-up Power (dBm)	Measured SAR(1g) (W/kg)	Reported SAR(1g) (W/kg)	Power Drift(dB)
MHz	Ch.								
Ambient Temperature: 22.6°C Liquid Temperature: 22.1°C									
Test Data (0mm)									
2535	21100	1RB_Mid	Rear	/	12.33	13.5	0.885	1.16	-0.02
2535	21100	50RB_Mid	Rear	/	12.21	13.5	0.860	1.16	0.00
2535	21100	1RB_Mid	Right	/	12.33	13.5	0.427	0.56	0.01
2535	21100	50RB_Mid	Right	/	12.21	13.5	0.322	0.43	-0.04
2535	21100	1RB_Mid	Top	/	12.33	13.5	0.689	0.90	0.03
2535	21100	50RB_Mid	Top	/	12.21	13.5	0.678	0.91	0.02
2560	21350	1RB_Mid	Rear	Fig.8	12.23	13.5	0.938	1.26	0.07
2510	20850	1RB_Mid	Rear	/	12.44	13.5	0.830	1.06	-0.05
2560	21350	50RB_High	Rear	/	12.25	13.5	0.937	1.25	0.05
2510	20850	50RB_Low	Rear	/	12.28	13.5	0.818	1.08	-0.02
2535	21100	100RB	Rear	/	12.27	13.5	0.922	1.22	-0.01
Test Data (14mm)									
2535	21100	1RB_Mid	Right	/	23.51	24	0.071	0.08	-0.03
2535	21100	50RB_Mid	Right	/	22.33	23	0.055	0.06	0.03
2535	21100	1RB_Mid	Top	/	23.51	24	0.674	0.75	-0.02
2535	21100	50RB_Mid	Top	/	22.33	23	0.517	0.60	-0.06
2560	21350	1RB_Mid	Top	/	23.44	24	0.801	0.91	-0.04
2510	20850	1RB_Mid	Top	/	23.6	24	0.564	0.62	-0.08
Test Data (15mm)									
2535	21100	1RB_Mid	Rear	/	23.51	24	0.473	0.53	0.04
2535	21100	50RB_Mid	Rear	/	22.33	23	0.366	0.43	0.05

Table 13.9: SAR Values (LTE Band 12 - Body)

Frequency		Test Mode	Test Position	Figure No.	Ambient Temperature: 22.7°C		Liquid Temperature: 22.2°C		
MHz	Ch.				Conducted Power (dBm)	Max. tune-up Power (dBm)	Measured SAR(1g) (W/kg)	Reported SAR(1g) (W/kg)	Power Drift(dB)
Test Data (0mm)									
707.5	23095	1RB_Mid	Rear	/	18.63	19.5	0.705	0.86	0.11
707.5	23095	25RB_Mid	Rear	/	18.57	19.5	0.698	0.86	0.02
707.5	23095	1RB_Mid	Right	/	18.63	19.5	0.309	0.38	0.04
707.5	23095	25RB_Mid	Right	/	18.57	19.5	0.248	0.31	0.14
707.5	23095	1RB_Mid	Top	/	18.63	19.5	0.312	0.38	0.03
707.5	23095	25RB_Mid	Top	/	18.57	19.5	0.311	0.39	0.03
711	23130	1RB_Mid	Rear	/	18.61	19.5	0.691	0.85	0.09
704	23060	1RB_Mid	Rear	/	18.70	19.5	0.712	0.86	0.05
711	23130	25RB_Mid	Rear	/	18.56	19.5	0.690	0.86	0.03
704	23060	25RB_High	Rear	Fig.9	18.67	19.5	0.747	0.90	0.04
Test Data (14mm)									
707.5	23095	1RB_Mid	Right	/	23.62	24	0.044	0.05	-0.02
707.5	23095	25RB_High	Right	/	22.49	23	0.032	0.04	-0.13
707.5	23095	1RB_Mid	Top	/	23.62	24	0.133	0.15	0.04
707.5	23095	25RB_High	Top	/	22.49	23	0.099	0.11	0.04
Test Data (15mm)									
707.5	23095	1RB_Mid	Rear	/	23.62	24	0.194	0.21	0.06
707.5	23095	25RB_High	Rear	/	22.49	23	0.150	0.17	0.03
711	23130	1RB_Mid	Rear	/	23.62	24	0.184	0.20	0.02
704	23060	1RB_Mid	Rear	/	23.61	24	0.195	0.21	0.09

Note: SAR for LTE Band 17 is covered by LTE Band 12 due to similar frequency range, same maximum tune-up limit and same channel bandwidth.

Table 13.10: SAR Values (LTE Band 66 - Body)

Frequency		Test Mode	Test Position	Figure No.	Ambient Temperature: 22.4°C		Liquid Temperature: 21.9°C		
MHz	Ch.				Conducted Power (dBm)	Max. tune-up Power (dBm)	Measured SAR(1g) (W/kg)	Reported SAR(1g) (W/kg)	Power Drift(dB)
Test Data (0mm)									
1745	132322	1RB_Mid	Rear	/	12.99	14	0.759	0.96	-0.03
1745	132322	50RB_Low	Rear	/	12.95	14	0.769	0.98	0.05
1745	132322	1RB_Mid	Right	/	12.99	14	0.092	0.12	0.06
1745	132322	50RB_Mid	Right	/	12.95	14	0.088	0.11	0.09
1745	132322	1RB_Mid	Top	/	12.99	14	0.245	0.31	0.02
1745	132322	50RB_Mid	Top	/	12.95	14	0.241	0.31	-0.03
1770	132572	1RB_Mid	Rear	/	13.07	14	0.808	1.00	0.08
1720	132072	1RB_Mid	Rear	/	13.00	14	0.714	0.90	0.05
1770	132572	50RB_Low	Rear	Fig.10	13.04	14	0.822	1.03	0.03
1720	132072	50RB_High	Rear	/	13.10	14	0.723	0.89	0.07
1745	132322	100RB	Rear	/	12.91	14	0.690	0.89	-0.06
Test Data (14mm)									
1745	132322	1RB_Mid	Right	/	23.17	24	0.150	0.18	-0.02
1745	132322	50RB_Low	Right	/	22.08	23	0.115	0.14	0.06
1745	132322	1RB_Mid	Top	/	23.17	24	0.388	0.47	-0.02
1745	132322	50RB_Low	Top	/	22.08	23	0.311	0.38	-0.04
Test Data (15mm)									
1745	132322	1RB_Mid	Rear	/	23.17	24	0.455	0.55	0.13
1770	132572	50RB_Low	Rear	/	22.08	23	0.346	0.43	0.09
1720	132072	1RB_Mid	Rear	/	23.23	24	0.609	0.73	0.11
1745	132322	1RB_Mid	Rear	/	23.23	24	0.373	0.45	0.11

Note: SAR for LTE Band 4 is covered by LTE Band 66 due to similar frequency range, same maximum tune-up limit and same channel bandwidth.

Table 13.11: SAR Values (LTE Band 71 - Body)

Frequency		Test Mode	Test Position	Figure No.	Conducted Power (dBm)	Max. tune-up Power (dBm)	Measured SAR(1g) (W/kg)	Reported SAR(1g) (W/kg)	Power Drift(dB)
MHz	Ch.								
Ambient Temperature: 22.7°C Liquid Temperature: 22.2°C									
Test Data (0mm)									
683	133322	1RB_Mid	Rear	Fig.11	17.86	19	0.590	0.77	0.08
683	133322	50RB_High	Rear	/	18.02	19	0.574	0.72	0.05
683	133322	1RB_Mid	Right	/	17.86	19	0.046	0.06	0.14
683	133322	50RB_High	Right	/	18.02	19	0.050	0.06	0.06
683	133322	1RB_Mid	Top	/	17.86	19	0.329	0.43	0.17
683	133322	50RB_High	Top	/	18.02	19	0.312	0.39	0.04
688	133372	1RB_Mid	Rear	/	18.08	19	0.566	0.70	0.04
673	133222	1RB_Mid	Rear	/	17.99	19	0.574	0.72	0.05
Test Data (14mm)									
683	133322	1RB_Mid	Right	/	23.28	24	0.073	0.09	0.08
683	133322	50RB_High	Right	/	22.29	23	0.059	0.07	-0.06
683	133322	1RB_Mid	Top	/	23.28	24	0.101	0.12	0.03
683	133322	50RB_High	Top	/	22.29	23	0.081	0.10	0.08
Test Data (15mm)									
683	133322	1RB_Mid	Rear	/	23.28	24	0.167	0.20	0.11
683	133322	50RB_High	Rear	/	22.29	23	0.140	0.16	0.02
688	133372	1RB_Mid	Rear	/	23.34	24	0.172	0.20	0.06
673	133222	1RB_Mid	Rear	/	23.38	24	0.149	0.17	0.06

13.2 WLAN Evaluation for 2.4G

According to the KDB248227 D01, SAR is measured for 2.4GHz 802.11b DSSS using the initial test position procedure.

Table 13.12: SAR Values (WLAN 2.4G - Body)

Frequency		Test Mode	Test Position	Figure No.	Conducted Power (dBm)	Max. tune-up Power (dBm)	Measured SAR(1g) (W/kg)	Reported SAR(1g) (W/kg)	Power Drift(dB)
MHz	Ch.								
Ambient Temperature: 22.3°C Liquid Temperature: 21.8°C									
Test Data (0mm)									
2437	6	802.11 b	Rear	/	10.92	11	0.263	0.27	0.09
2437	6	802.11 b	Left	/	10.92	11	0.127	0.13	0.14
2437	6	802.11 b	Top	/	10.92	11	0.222	0.23	0.01
Test Data (9mm)									
2437	6	802.11 b	Left	/	20.83	21	0.179	0.19	-0.03
2437	6	802.11 b	Top	Fig.12	20.83	21	0.376	0.39	0.08
Test Data (12mm)									
2437	6	802.11 b	Rear	/	20.83	21	0.258	0.27	0.01

Note1: For all positions/configurations tested using the initial test position and subsequent test positions, when the reported SAR is > 0.8 W/kg, SAR is measured for these test positions/configurations on the subsequent next highest measured output power channel until the reported SAR is ≤ 1.2 W/kg or all required channels are tested.

According to the KDB248227 D01, The reported SAR must be scaled to 100% transmission duty factor to determine compliance at the maximum tune-up tolerance limit.

Table 13.13: SAR Values (WLAN - Body) – 802.11b (Scaled Reported SAR)

Frequency		Test Position	Actual duty factor	maximum duty factor	Reported SAR (1g)(W/kg)	Scaled reported SAR (1g)(W/kg)
MHz	Ch.					
Ambient Temperature: 22.3°C Liquid Temperature: 21.8°C						
2437	6	Rear-0mm	100%	100%	0.27	0.27
2437	6	Top-9mm	100%	100%	0.39	0.39

SAR is not required for OFDM because the 802.11b adjusted SAR ≤ 1.2 W/kg.

13.3 WLAN Evaluation for 5G

Table 13.14: SAR Values (WLAN 5G - Body) - Test Data (0mm)

Frequency		Test Mode	Test Position	Figure No.	Conducted Power (dBm)	Max. tune-up Power (dBm)	Measured SAR(1g) (W/kg)	Reported SAR(1g) (W/kg)	Power Drift(dB)
MHz	Ch.								
Ambient Temperature: 22.9°C Liquid Temperature: 22.4°C									
U-NII-2A									
5260	52	802.11 a	Rear	/	6.49	7	0.175	0.20	0.00
5260	52	802.11 a	Left	/	6.49	7	0.003	< 0.01	0.04
5260	52	802.11 a	Top	/	6.49	7	0.061	0.07	0.05
U-NII-3									
5765	153	802.11 a	Rear	/	6.47	7	0.232	0.26	-0.03
5765	153	802.11 a	Left	/	6.47	7	0.022	0.03	0.04
5765	153	802.11 a	Top	/	6.47	7	0.046	0.05	0.05

Table 13.15: SAR Values (WLAN 5G - Body) - Test Data (9mm)

Frequency		Test Mode	Test Position	Figure No.	Conducted Power (dBm)	Max. tune-up Power (dBm)	Measured SAR(1g) (W/kg)	Reported SAR(1g) (W/kg)	Power Drift(dB)
MHz	Ch.								
Ambient Temperature: 22.9°C Liquid Temperature: 22.4°C									
U-NII-2A									
5260	52	802.11 a	Left	/	18.98	19	0.108	0.11	0.03
5260	52	802.11 a	Top	/	18.98	19	0.310	0.31	0.05
U-NII-3									
5745	149	802.11 a	Left	/	19.1	19.5	0.194	0.21	0.06
5745	149	802.11 a	Top	/	19.1	19.5	0.288	0.32	0.02

Table 13.16: SAR Values (WLAN 5G - Body) - Test Data (12mm)

Frequency		Test Mode	Test Position	Figure No.	Conducted Power (dBm)	Max. tune-up Power (dBm)	Measured SAR(1g) (W/kg)	Reported SAR(1g) (W/kg)	Power Drift(dB)
MHz	Ch.								
Ambient Temperature: 22.9°C Liquid Temperature: 22.4°C									
U-NII-2A									
5260	52	802.11 a	Rear	/	18.98	19	0.259	0.26	0.00
U-NII-3									
5745	149	802.11 a	Rear	Fig.13	19.1	19.5	0.368	0.40	0.09

Note1: U-NII-1 and U-NII-2A bands have the same specified maximum output and tolerance; SAR is measured for U-NII-2A band first. Adjusted SAR of U-NII-2A band is ≤ 1.2 W/kg, SAR is not required for U-NII-1 band.

Note2: For all positions/configurations tested using the initial test position and subsequent test positions, when the reported SAR is > 0.8 W/kg, SAR is measured for these test positions/configurations on the subsequent next highest measured output power channel until the reported SAR is ≤ 1.2 W/kg or all required channels are tested.

According to the KDB248227 D01, The reported SAR must be scaled to 100% transmission duty factor to determine compliance at the maximum tune-up tolerance limit.

Table 13.17: SAR Values (WLAN - Body) – 802.11a (Scaled Reported SAR)

Frequency		Test Position	Actual duty factor	maximum duty factor	Reported SAR (1g)(W/kg)	Scaled reported SAR (1g)(W/kg)
MHz	Ch.					
Ambient Temperature: 22.6°C Liquid Temperature: 22.0°C						
5745	149	Rear-0mm	100%	100%	0.26	0.26
5745	149	Top-9mm	100%	100%	0.32	0.32
5745	149	Rear-12mm	100%	100%	0.40	0.40

14 SAR Measurement Variability

SAR measurement variability must be assessed for each frequency band, which is determined by the SAR probe calibration point and tissue-equivalent medium used for the device measurements. When both head and body tissue-equivalent media are required for SAR measurements in a frequency band, the variability measurement procedures should be applied to the tissue medium with the highest measured SAR, using the highest measured SAR configuration for that tissue-equivalent medium.

The following procedures are applied to determine if repeated measurements are required.

- 1) Repeated measurement is not required when the original highest measured SAR is < 0.80 W/kg; steps 2) through 4) do not apply.
- 2) When the original highest measured SAR is ≥ 0.80 W/kg, repeat that measurement once.
- 3) Perform a second repeated measurement only if the ratio of largest to smallest SAR for the original and first repeated measurements is > 1.20 or when the original or repeated measurement is ≥ 1.45 W/kg (~ 10% from the 1-g SAR limit).
- 4) Perform a third repeated measurement only if the original, first or second repeated measurement is ≥ 1.5 W/kg and the ratio of largest to smallest SAR for the original, first and second repeated measurements is > 1.20.

Table 14.1: SAR Measurement Variability for Body – GSM1900

Frequency		Test Position	Original	1 st Repeated	Ratio	2 nd Repeated
MHz	Ch.		SAR (W/kg)	SAR (W/kg)		SAR (W/kg)
1909.8	810	Rear	0.945	0.937	1.01	/

Table 14.2: SAR Measurement Variability for Body – WCDMA 850

Frequency		Test Position	Original	1 st Repeated	Ratio	2 nd Repeated
MHz	Ch.		SAR (W/kg)	SAR (W/kg)		SAR (W/kg)
836.4	4182	Rear	1.16	1.13	1.03	/

Table 14.3: SAR Measurement Variability for Body – WCDMA 1900

Frequency		Test Position	Original	1 st Repeated	Ratio	2 nd Repeated
MHz	Ch.		SAR (W/kg)	SAR (W/kg)		SAR (W/kg)
1907.6	9538	Rear	1.23	1.18	1.04	/

Table 14.4: SAR Measurement Variability for Body – LTE Band 2

Frequency		Test Position	Original	1 st Repeated	Ratio	2 nd Repeated
MHz	Ch.		SAR (W/kg)	SAR (W/kg)		SAR (W/kg)
1900	19100	Rear	0.942	0.935	1.01	/

Table 14.5: SAR Measurement Variability for Body –LTE Band 7

Frequency		Test Position	Original	1 st Repeated	Ratio	2 nd Repeated
MHz	Ch.		SAR (W/kg)	SAR (W/kg)		SAR (W/kg)
2560	21350	Rear	0.938	0.929	1.01	/

Table 14.6: SAR Measurement Variability for Body –LTE Band 66

Frequency		Test Position	Original	1 st Repeated	Ratio	2 nd Repeated
MHz	Ch.		SAR (W/kg)	SAR (W/kg)		SAR (W/kg)
1770	132572	Rear	0.822	0.809	1.02	/

15 Measurement Uncertainty

15.1 Measurement Uncertainty for Normal SAR Tests (300MHz~3GHz)

No.	Error Description	Type	Uncertainty value	Probably Distribution	Div.	(Ci) 1g	(Ci) 10g	Std. Unc. (1g)	Std. Unc. (10g)	Degree of freedom
Measurement system										
1	Probe calibration	B	12	N	2	1	1	6.0	6.0	∞
2	Isotropy	B	7.4	R	$\sqrt{3}$	1	1	4.3	4.3	∞
3	Boundary effect	B	1.1	R	$\sqrt{3}$	1	1	0.6	0.6	∞
4	Linearity	B	4.7	R	$\sqrt{3}$	1	1	2.7	2.7	∞
5	Detection limit	B	1.0	R	$\sqrt{3}$	1	1	0.6	0.6	∞
6	Readout electronics	B	1.0	N	1	1	1	1.0	1.0	∞
7	Response time	B	0.0	R	$\sqrt{3}$	1	1	0.0	0.0	∞
8	Integration time	B	1.7	R	$\sqrt{3}$	1	1	1.0	1.0	∞
9	RF ambient conditions-noise	B	3.0	R	$\sqrt{3}$	1	1	1.7	1.7	∞
10	RF ambient conditions-reflection	B	3.0	R	$\sqrt{3}$	1	1	1.7	1.7	∞
11	Probe positioned mech. restrictions	B	0.35	R	$\sqrt{3}$	1	1	0.2	0.2	∞
12	Probe positioning with respect to phantom shell	B	2.9	R	$\sqrt{3}$	1	1	1.7	1.7	∞
13	Post-processing	B	1.0	R	$\sqrt{3}$	1	1	0.6	0.6	∞
Test sample related										
14	Test sample positioning	A	3.3	N	1	1	1	3.3	3.3	5
15	Device holder uncertainty	A	3.4	N	1	1	1	3.4	3.4	5
16	Drift of output power	B	5.0	R	$\sqrt{3}$	1	1	2.9	2.9	∞
Phantom and set-up										
17	Phantom uncertainty	B	1.0	R	$\sqrt{3}$	1	1	0.6	0.6	∞
18	Liquid conductivity (target)	B	5.0	R	$\sqrt{3}$	0.64	0.43	1.8	1.2	∞
19	Liquid conductivity (meas.)	A	1.3	N	1	0.64	0.43	0.83	0.56	9
20	Liquid permittivity (target)	B	5.0	R	$\sqrt{3}$	0.6	0.49	1.7	1.4	∞
21	Liquid permittivity (meas.)	A	1.6	N	1	0.6	0.49	0.96	0.78	9
Combined standard uncertainty		$u_c = \sqrt{\sum_{i=1}^{21} c_i^2 u_i^2}$						10.4	10.3	95.5
Expanded uncertainty (Confidence interval of 95 %)		$u_e = 2u_c$						20.8	20.6	

15.2 Measurement Uncertainty for Fast SAR Tests (300MHz~3GHz)

No.	Error Description	Type	Uncertainty value	Probably Distribution	Div.	(Ci) 1g	(Ci) 10g	Std. Unc. (1g)	Std. Unc. (10g)	Degree of freedom
Measurement system										
1	Probe calibration	B	12	N	2	1	1	6.0	6.0	∞
2	Isotropy	B	7.4	R	$\sqrt{3}$	1	1	4.3	4.3	∞
3	Boundary effect	B	1.1	R	$\sqrt{3}$	1	1	0.6	0.6	∞
4	Linearity	B	4.7	R	$\sqrt{3}$	1	1	2.7	2.7	∞
5	Detection limit	B	1.0	R	$\sqrt{3}$	1	1	0.6	0.6	∞
6	Readout electronics	B	1.0	N	1	1	1	1.0	1.0	∞
7	Response time	B	0.0	R	$\sqrt{3}$	1	1	0.0	0.0	∞
8	Integration time	B	1.7	R	$\sqrt{3}$	1	1	1.0	1.0	∞
9	RF ambient conditions-noise	B	3.0	R	$\sqrt{3}$	1	1	1.7	1.7	∞
10	RF ambient conditions-reflection	B	3.0	R	$\sqrt{3}$	1	1	1.7	1.7	∞
11	Probe positioned mech. Restrictions	B	0.35	R	$\sqrt{3}$	1	1	0.2	0.2	∞
12	Probe positioning with respect to phantom shell	B	2.9	R	$\sqrt{3}$	1	1	1.7	1.7	∞
13	Post-processing	B	1.0	R	$\sqrt{3}$	1	1	0.6	0.6	∞
14	Fast SAR z-Approximation	B	7.0	R	$\sqrt{3}$	1	1	4.0	4.0	∞
Test sample related										
15	Test sample positioning	A	3.3	N	1	1	1	3.3	3.3	5
16	Device holder uncertainty	A	3.4	N	1	1	1	3.4	3.4	5
17	Drift of output power	B	5.0	R	$\sqrt{3}$	1	1	2.9	2.9	∞
Phantom and set-up										
18	Phantom uncertainty	B	1.0	R	$\sqrt{3}$	1	1	0.6	0.6	∞
19	Liquid conductivity (target)	B	5.0	R	$\sqrt{3}$	0.64	0.43	1.8	1.2	∞
20	Liquid conductivity (meas.)	A	1.3	N	1	0.64	0.43	0.83	0.56	43
21	Liquid permittivity (target)	B	5.0	R	$\sqrt{3}$	0.6	0.49	1.7	1.4	∞
22	Liquid permittivity (meas.)	A	1.6	N	1	0.6	0.49	0.96	0.78	521
Combined standard uncertainty		$u_c = \sqrt{\sum_{i=1}^{22} c_i^2 u_i^2}$						11.1	11.0	257
Expanded uncertainty (Confidence interval of 95 %)		$u_e = 2u_c$						22.2	22.0	

15.3 Measurement Uncertainty for Normal SAR Tests (3GHz~6GHz)

No.	Error Description	Type	Uncertainty value	Probably Distribution	Div.	(Ci) 1g	(Ci) 10g	Std. Unc. (1g)	Std. Unc. (10g)	Degree of freedom
Measurement system										
1	Probe calibration	B	13	N	2	1	1	6.5	6.5	∞
2	Isotropy	B	7.4	R	$\sqrt{3}$	1	1	4.3	4.3	∞
3	Boundary effect	B	2.3	R	$\sqrt{3}$	1	1	1.3	1.3	∞
4	Linearity	B	4.7	R	$\sqrt{3}$	1	1	2.7	2.7	∞
5	Detection limit	B	1.0	R	$\sqrt{3}$	1	1	0.6	0.6	∞
6	Readout electronics	B	1.0	N	1	1	1	1.0	1.0	∞
7	Response time	B	0.0	R	$\sqrt{3}$	1	1	0.0	0.0	∞
8	Integration time	B	1.7	R	$\sqrt{3}$	1	1	1.0	1.0	∞
9	RF ambient conditions-noise	B	3.0	R	$\sqrt{3}$	1	1	1.7	1.7	∞
10	RF ambient conditions-reflection	B	3.0	R	$\sqrt{3}$	1	1	1.7	1.7	∞
11	Probe positioned mech. restrictions	B	0.71	R	$\sqrt{3}$	1	1	0.4	0.4	∞
12	Probe positioning with respect to phantom shell	B	5.7	R	$\sqrt{3}$	1	1	3.3	3.3	∞
13	Post-processing	B	4.0	R	$\sqrt{3}$	1	1	2.3	2.3	∞
Test sample related										
14	Test sample positioning	A	3.3	N	1	1	1	3.3	3.3	5
15	Device holder uncertainty	A	3.4	N	1	1	1	3.4	3.4	5
16	Drift of output power	B	5.0	R	$\sqrt{3}$	1	1	2.9	2.9	∞
Phantom and set-up										
17	Phantom uncertainty	B	1.0	R	$\sqrt{3}$	1	1	0.6	0.6	∞
18	Liquid conductivity (target)	B	5.0	R	$\sqrt{3}$	0.64	0.43	1.8	1.2	∞
19	Liquid conductivity (meas.)	A	1.3	N	1	0.64	0.43	0.83	0.56	9
20	Liquid permittivity (target)	B	5.0	R	$\sqrt{3}$	0.6	0.49	1.7	1.4	∞
21	Liquid permittivity (meas.)	A	1.6	N	1	0.6	0.49	0.96	0.78	9
Combined standard uncertainty		$u_c = \sqrt{\sum_{i=1}^{21} c_i^2 u_i^2}$						11.3	11.2	95.5
Expanded uncertainty (Confidence interval of 95 %)		$u_e = 2u_c$						22.6	22.4	

15.4 Measurement Uncertainty for Fast SAR Tests (3GHz~6GHz)

No.	Error Description	Type	Uncertainty value	Probably Distribution	Div	(Ci) 1g	(Ci) 10g	Std. Unc. (1g)	Std. Unc. (10g)	Degree of freedom
Measurement system										
1	Probe calibration	B	13	N	2	1	1	6.5	6.5	∞
2	Isotropy	B	7.4	R	$\sqrt{3}$	1	1	4.3	4.3	∞
3	Boundary effect	B	2.3	R	$\sqrt{3}$	1	1	1.3	1.3	∞
4	Linearity	B	4.7	R	$\sqrt{3}$	1	1	2.7	2.7	∞
5	Detection limit	B	1.0	R	$\sqrt{3}$	1	1	0.6	0.6	∞
6	Readout electronics	B	1.0	N	1	1	1	1.0	1.0	∞
7	Response time	B	0.0	R	$\sqrt{3}$	1	1	0.0	0.0	∞
8	Integration time	B	1.7	R	$\sqrt{3}$	1	1	1.0	1.0	∞
9	RF ambient conditions-noise	B	3.0	R	$\sqrt{3}$	1	1	1.7	1.7	∞
10	RF ambient conditions-reflection	B	3.0	R	$\sqrt{3}$	1	1	1.7	1.7	∞
11	Probe positioned mech. Restrictions	B	0.71	R	$\sqrt{3}$	1	1	0.4	0.4	∞
12	Probe positioning with respect to phantom shell	B	5.7	R	$\sqrt{3}$	1	1	3.3	3.3	∞
13	Post-processing	B	4.0	R	$\sqrt{3}$	1	1	2.3	2.3	∞
14	Fast SAR z-Approximation	B	14.0	R	$\sqrt{3}$	1	1	8.1	8.1	∞
Test sample related										
15	Test sample positioning	A	3.3	N	1	1	1	3.3	3.3	5
16	Device holder uncertainty	A	3.4	N	1	1	1	3.4	3.4	5
17	Drift of output power	B	5.0	R	$\sqrt{3}$	1	1	2.9	2.9	∞
Phantom and set-up										
18	Phantom uncertainty	B	1.0	R	$\sqrt{3}$	1	1	0.6	0.6	∞
19	Liquid conductivity (target)	B	5.0	R	$\sqrt{3}$	0.64	0.43	1.8	1.2	∞
20	Liquid conductivity (meas.)	A	1.3	N	1	0.64	0.43	0.83	0.56	43
21	Liquid permittivity (target)	B	5.0	R	$\sqrt{3}$	0.6	0.49	1.7	1.4	∞
22	Liquid permittivity (meas.)	A	1.6	N	1	0.6	0.49	0.96	0.78	521
Combined standard uncertainty		$u_c = \sqrt{\sum_{i=1}^{22} c_i^2 u_i^2}$						13.9	13.9	257
Expanded uncertainty (Confidence interval of 95 %)		$u_e = 2u_c$						27.8	27.7	

16 Main Test Instruments

Table 16.1: List of Main Instruments

No.	Name	Type	Serial Number	Calibration Date	Valid Period
01	Network analyzer	Agilent E5071C	MY46103759	2018-11-16	One year
02	Dielectric probe	85070E	MY44300317	/	/
03	Power meter	E4418B	MY50000366	2018-12-14	One year
04	Power sensor	E9304A	MY50000188		
05	Power meter	NRP	101460	2019-02-04	One year
06	Power sensor	NRP-Z91	100553		
07	Signal Generator	E8257D	MY47461211	2018-06-04	One year
08	Amplifier	VTL5400	0404	/	/
09	E-field Probe	SPEAG EX3DV4	3633	2019-02-26	One year
10	DAE	SPEAG DAE4	786	2019-01-11	One year
11	Dipole Validation Kit	SPEAG D750V3	1163	2016-09-19	Three year
12	Dipole Validation Kit	SPEAG D835V2	4d057	2018-10-09	Three year
13	Dipole Validation Kit	SPEAG D1750V2	1152	2016-09-09	Three year
14	Dipole Validation Kit	SPEAG D1900V2	5d088	2018-10-24	Three year
15	Dipole Validation Kit	SPEAG D2450V2	873	2018-10-26	Three year
16	Dipole Validation Kit	SPEAG D2550V2	1058	2018-08-24	Three year
17	Dipole Validation Kit	SPEAG D5GHzV2	1238	2016-09-21	Three year
18	Radio Communication Analyzer	Anristu MT8820C	6201341853	2019-03-07	One year
19	BTS	E5515C	GB46110722	2019-01-18	One year

END OF REPORT BODY

ANNEX A Graph Results

GSM850 Body

Date: 2019-3-19

Electronics: DAE4 Sn786

Medium: Body 835 MHz

Medium parameters used (interpolated): $f = 824.2$ MHz; $\sigma = 0.978$ S/m; $\epsilon_r = 52.79$; $\rho = 1000$ kg/m³

Ambient Temperature: 22.0°C Liquid Temperature: 21.5°C

Communication System: UID 0, GPRS 4Txslot (0) Frequency: 824.4 MHz Duty Cycle: 1:2

Probe: EX3DV4 – SN3633 ConvF (9.56, 9.56, 9.56);

Rear Side Low/Area Scan (141x91x1): Interpolated grid: dx=1.500 mm, dy=1.500 mm

Maximum value of SAR (interpolated) = 1.28 W/kg

Rear Side Low/Zoom Scan (5x5x7)/Cube 0: Measurement grid: dx=8mm, dy=8mm, dz=5mm

Reference Value = 6.745 V/m; Power Drift = 0.13 dB

Peak SAR (extrapolated) = 1.30 W/kg

SAR(1 g) = 0.668 W/kg; SAR(10 g) = 0.392 W/kg

Maximum value of SAR (measured) = 0.813 W/kg

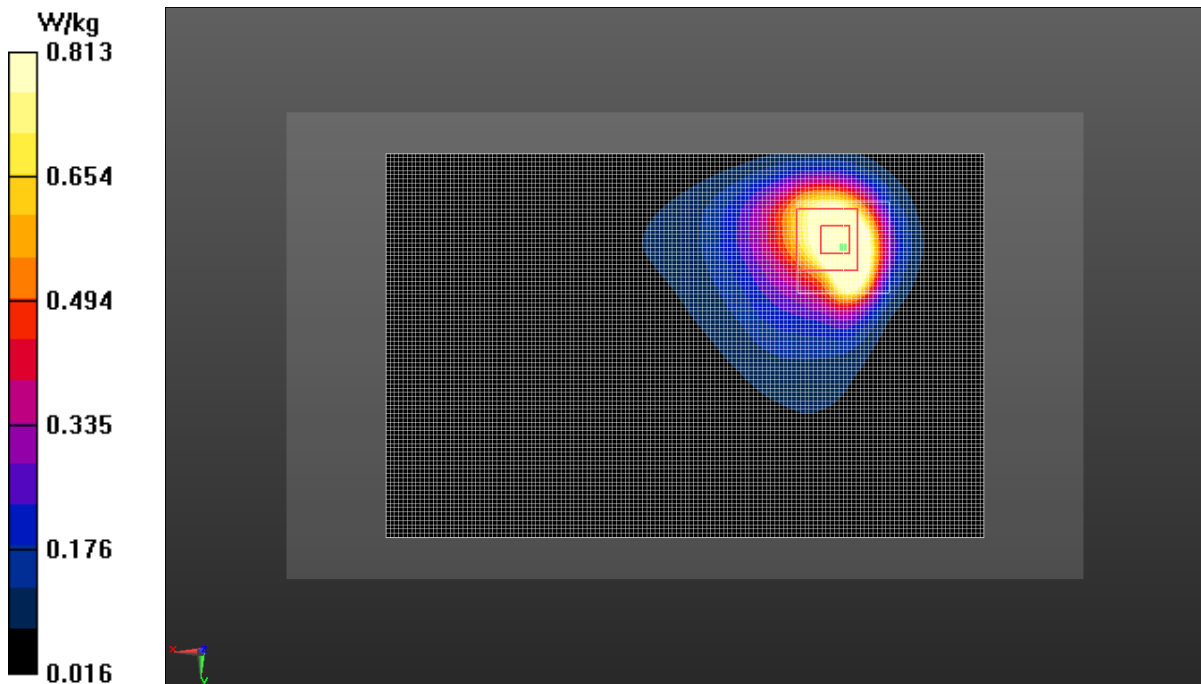

Fig.1 GSM 850 MHz

GSM1900 Body

Date: 2019-3-24

Electronics: DAE4 Sn786

Medium: Body 1900 MHz

Medium parameters used: $f = 1910 \text{ MHz}$; $\sigma = 1.583 \text{ S/m}$; $\epsilon_r = 52.941$; $\rho = 1000 \text{ kg/m}^3$

Ambient Temperature: 22.0°C Liquid Temperature: 21.5°C

Communication System: UID 0, GPRS 4Txslot (0) Frequency: 1909.8 MHz Duty Cycle: 1:2

Probe: EX3DV4 – SN3633 ConvF (7.67, 7.67, 7.67);

Rear Side High /Area Scan (71x61x1): Interpolated grid: $dx=1.500 \text{ mm}$, $dy=1.500 \text{ mm}$

Maximum value of SAR (interpolated) = 1.33 W/kg

Rear Side High/Zoom Scan (5x5x7)/Cube 0: Measurement grid: $dx=8\text{mm}$, $dy=8\text{mm}$, $dz=5\text{mm}$

Reference Value = 1.864 V/m ; Power Drift = 0.07 dB

Peak SAR (extrapolated) = 2.06 W/kg

SAR(1 g) = 0.945 W/kg ; SAR(10 g) = 0.359 W/kg

Maximum value of SAR (measured) = 1.17 W/kg

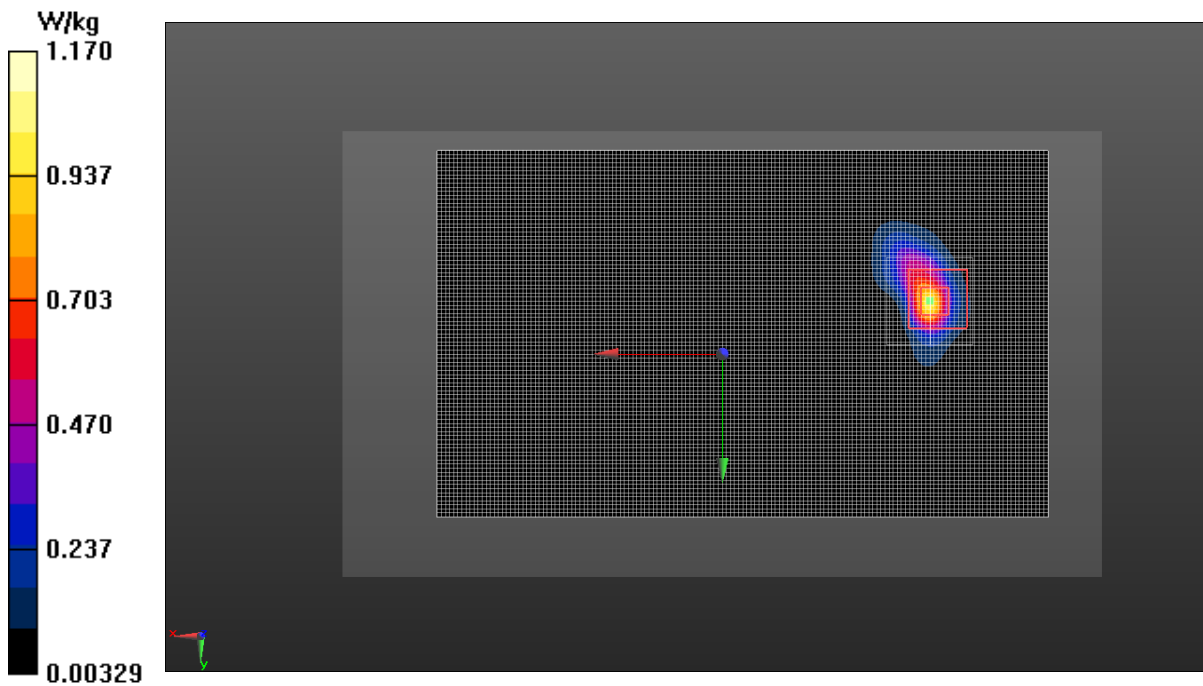

Fig.2 GSM 1900 MHz

WCDMA 850 Body

Date: 2019-3-19

Electronics: DAE4 Sn786

Medium: Body 835 MHz

Medium parameters used (interpolated): $f = 826.4$ MHz; $\sigma = 0.98$ S/m; $\epsilon_r = 52.769$; $\rho = 1000$ kg/m³

Ambient Temperature: 22.0°C Liquid Temperature: 21.5°C

Communication System: UID 0, WCDMA (0) Frequency: 826.4 MHz Duty Cycle: 1:1

Probe: EX3DV4 – SN3633 ConvF (9.56, 9.56, 9.56);

Rear Side Low /Area Scan (141x91x1): Interpolated grid: dx=1.500 mm, dy=1.500 mm

Maximum value of SAR (interpolated) = 1.70 W/kg

Rear Side Low/Zoom Scan (5x5x7)/Cube 0: Measurement grid: dx=8mm, dy=8mm, dz=5mm

Reference Value = 9.110 V/m; Power Drift = 0.11 dB

Peak SAR (extrapolated) = 2.26 W/kg

SAR(1 g) = 1.16 W/kg; SAR(10 g) = 0.692 W/kg

Maximum value of SAR (measured) = 1.44 W/kg

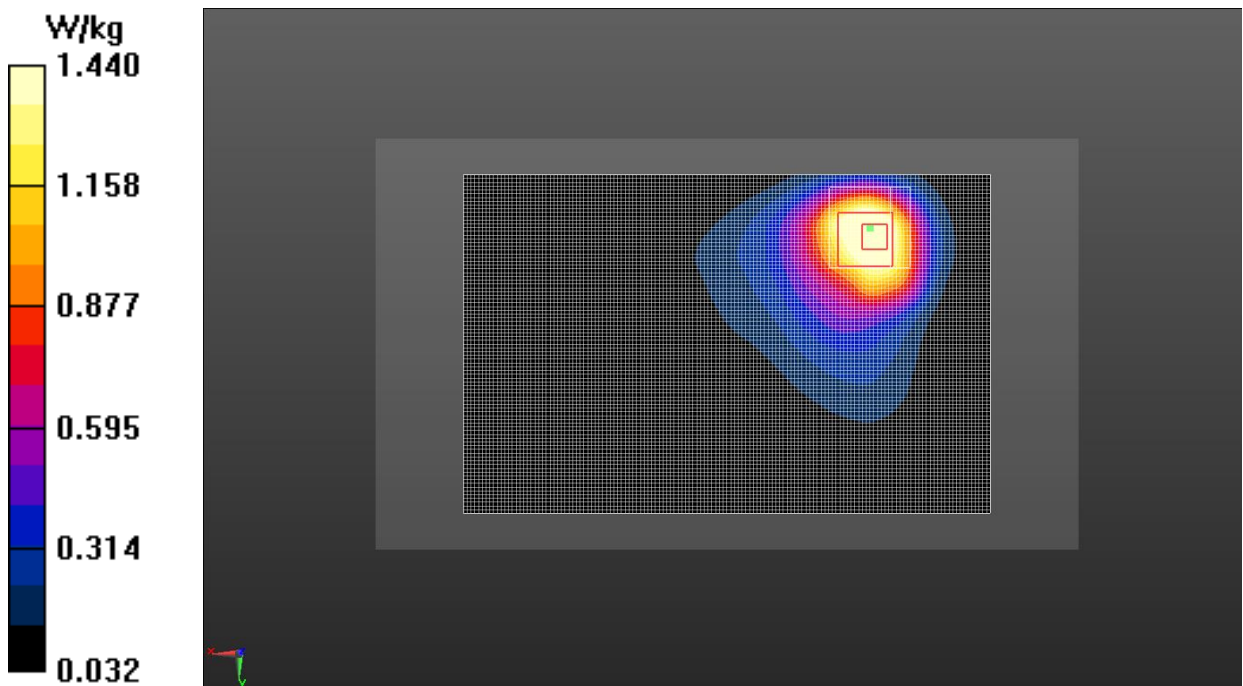

Fig.3 WCDMA 850

WCDMA 1900 Body

Date: 2019-3-24

Electronics: DAE4 Sn786

Medium: Body 1900 MHz

Medium parameters used: $f = 1908$ MHz; $\sigma = 1.582$ S/m; $\epsilon_r = 52.945$; $\rho = 1000$ kg/m³

Ambient Temperature: 22.0°C Liquid Temperature: 21.5°C

Communication System: UID 0, WCDMA (0) Frequency: 1907.6 MHz Duty Cycle: 1:1

Probe: EX3DV4 – SN3633 ConvF (7.67, 7.67, 7.67);

Rear Side High/Area Scan (141x91x1): Interpolated grid: dx=1.500 mm, dy=1.500 mm

Maximum value of SAR (interpolated) = 2.20 W/kg

Rear Side High/Zoom Scan (5x5x7)/Cube 0: Measurement grid: dx=8mm, dy=8mm, dz=5mm

Reference Value = 1.397 V/m; Power Drift = 0.04 dB

Peak SAR (extrapolated) = 2.90 W/kg

SAR(1 g) = 1.23 W/kg; SAR(10 g) = 0.460 W/kg

Maximum value of SAR (measured) = 2.27 W/kg

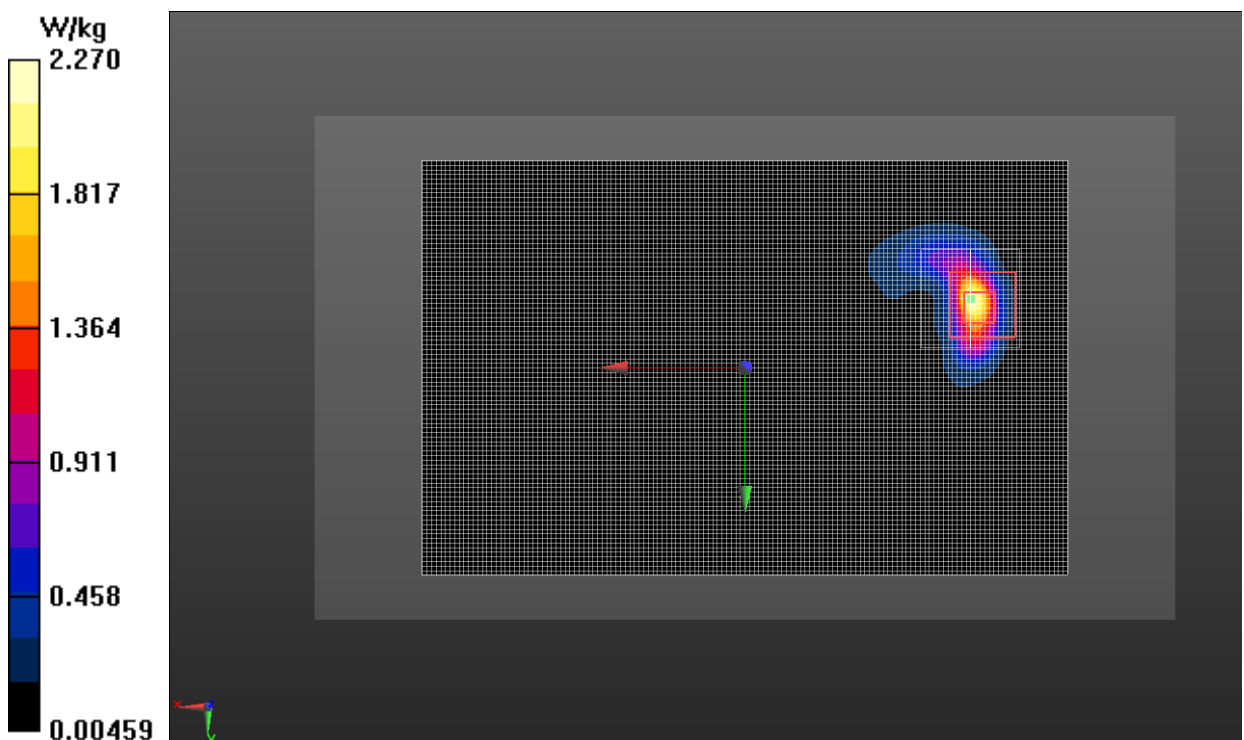

Fig.4 WCDMA 1900

WCDMA 1700 Body

Date: 2019-3-14

Electronics: DAE4 Sn786

Medium: Body 1750 MHz

Medium parameters used (interpolated): $f = 1752.6$ MHz; $\sigma = 1.46$ S/m; $\epsilon_r = 53.382$; $\rho = 1000$ kg/m³

Ambient Temperature: 22.0°C Liquid Temperature: 21.5°C

Communication System: UID 0, WCDMA (0) Frequency: 1752.6 MHz Duty Cycle: 1:1

Probe: EX3DV4 – SN3633 ConvF (7.93, 7.93, 7.93);

Rear Side High /Area Scan (141x91x1): Interpolated grid: dx=1.500 mm, dy=1.500 mm

Maximum value of SAR (interpolated) = 1.56 W/kg

Rear Side High/Zoom Scan (5x5x7)/Cube 0: Measurement grid: dx=8mm, dy=8mm, dz=5mm

Reference Value = 1.713 V/m; Power Drift = 0.02 dB

Peak SAR (extrapolated) = 1.81 W/kg

SAR(1 g) = 0.785 W/kg; SAR(10 g) = 0.308 W/kg

Maximum value of SAR (measured) = 1.07 W/kg

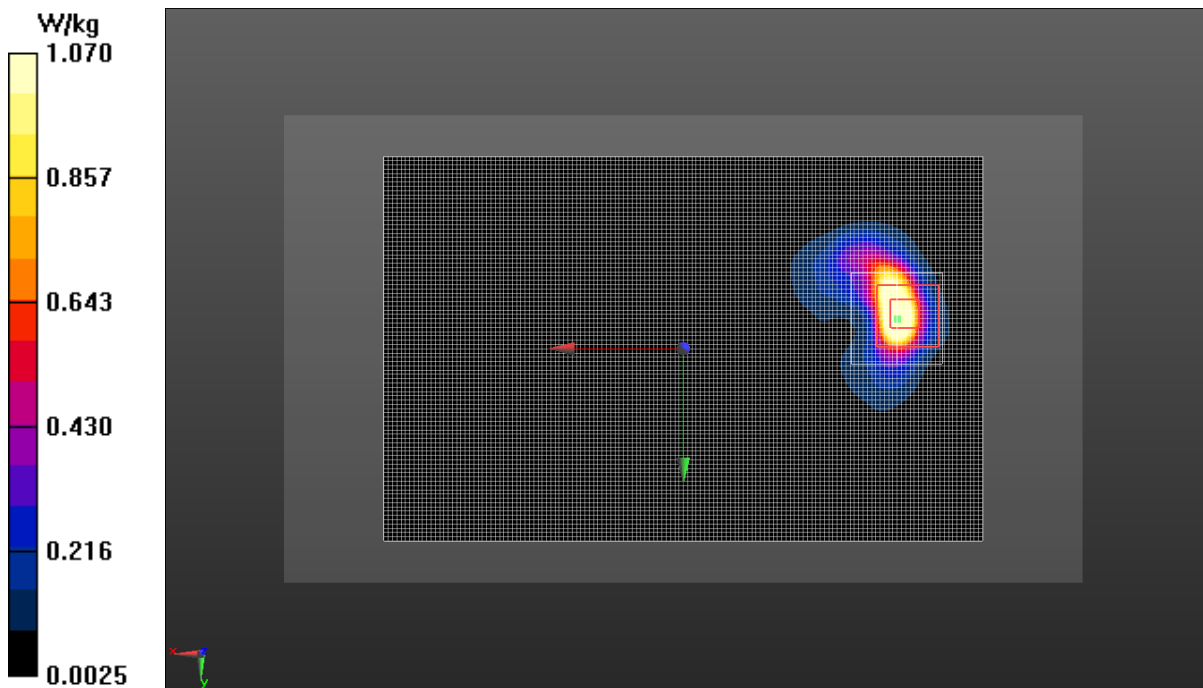

Fig.5 WCDMA 1700

LTE Band 2 Body

Date: 2019-3-24

Electronics: DAE4 Sn786

Medium: Body 1900 MHz

Medium parameters used: $f = 1900$ MHz; $\sigma = 1.574$ S/m; $\epsilon_r = 52.954$; $\rho = 1000$ kg/m³

Ambient Temperature: 22.0°C Liquid Temperature: 21.5°C

Communication System: UID 0, LTE_FDD (0) Frequency: 1900 MHz Duty Cycle: 1:1

Probe: EX3DV4 – SN3633 ConvF (7.67, 7.67, 7.67);

Rear Side High 1RB_Mid/Area Scan (51x51x1): Interpolated grid: dx=1.500 mm, dy=1.500 mm

Maximum value of SAR (interpolated) = 0.836 W/kg

Rear Side High 1RB_Mid/Zoom Scan (5x5x7)/Cube 0: Measurement grid: dx=8mm, dy=8mm, dz=5mm

Reference Value = 1.030 V/m; Power Drift = 0.04 dB

Peak SAR (extrapolated) = 2.28 W/kg

SAR(1 g) = 0.942 W/kg; SAR(10 g) = 0.365 W/kg

Maximum value of SAR (measured) = 1.19 W/kg

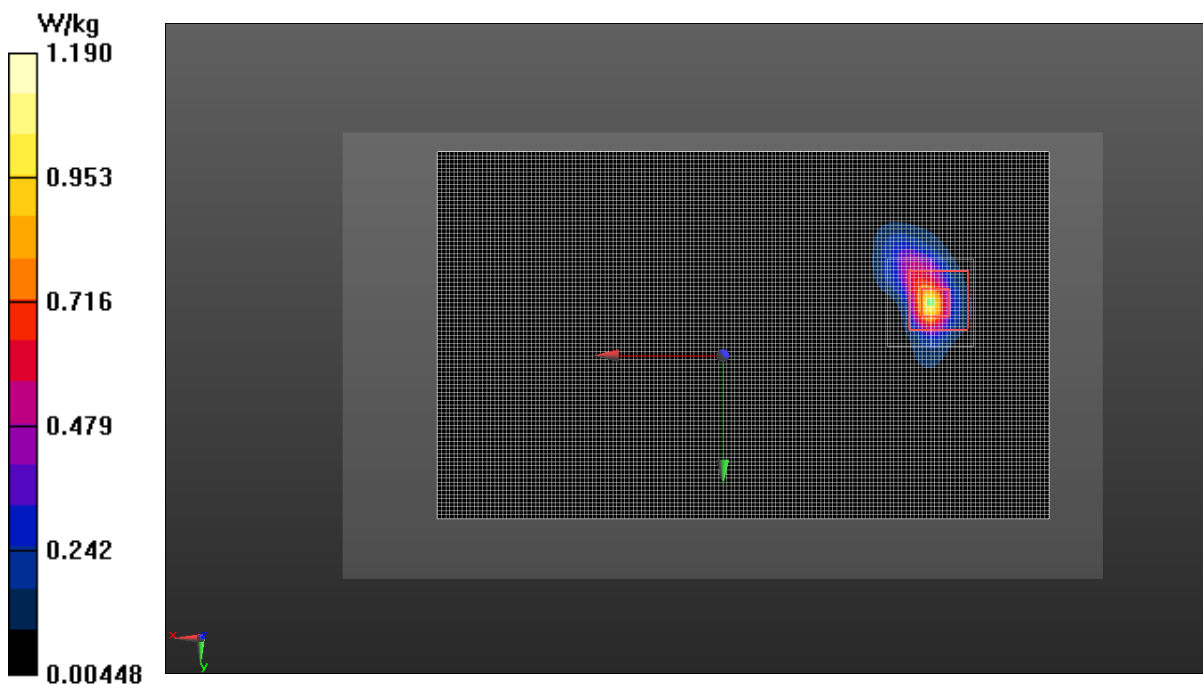

Fig.6 LTE Band 2

LTE Band 5 Body

Date: 2019-3-19

Electronics: DAE4 Sn786

Medium: Body 835 MHz

Medium parameters used (interpolated): $f = 829$ MHz; $\sigma = 983$ S/m; $\epsilon_r = 52.743$; $\rho = 1000$ kg/m³

Ambient Temperature: 22.0°C Liquid Temperature: 21.5°C

Communication System: UID 0, LTE_FDD (0) Frequency: 829 MHz Duty Cycle: 1:1

Probe: EX3DV4 – SN3633 ConvF (9.56, 9.56, 9.56);

Rear Side Low 1RB_Mid/Area Scan (51x51x1): Interpolated grid: dx=1.500 mm, dy=1.500 mm

Maximum value of SAR (interpolated) = 0.714 W/kg

Rear Side Low 1RB_Mid/Zoom Scan (5x5x7)/Cube 0: Measurement grid: dx=8mm, dy=8mm, dz=5mm

Reference Value = 4.476 V/m; Power Drift = 0.06 dB

Peak SAR (extrapolated) = 0.849 W/kg

SAR(1 g) = 0.452 W/kg; SAR(10 g) = 0.266 W/kg

Maximum value of SAR (measured) = 0.534 W/kg

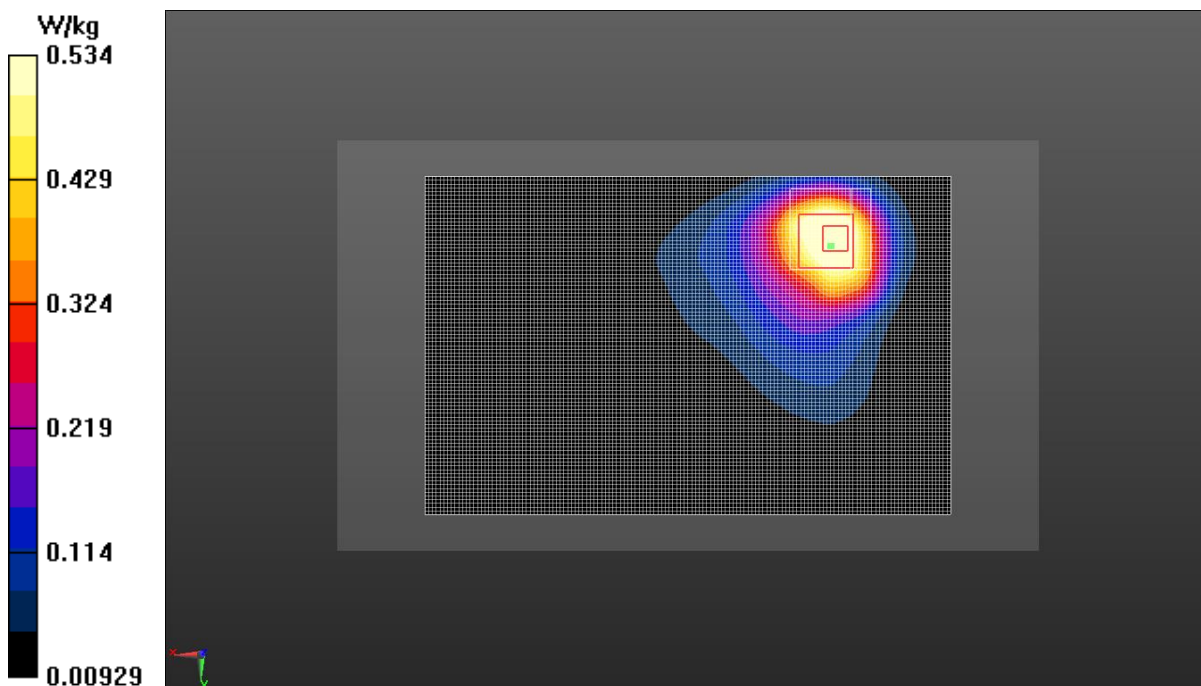

Fig.7 LTE Band 5

LTE Band 7 Body

Date: 2019-3-20

Electronics: DAE4 Sn786

Medium: Body 2550 MHz

Medium parameters used: $f = 2560$ MHz; $\sigma = 2.064$ S/m; $\epsilon_r = 50.183$; $\rho = 1000$ kg/m³

Ambient Temperature: 22.0°C Liquid Temperature: 21.5°C

Communication System: UID 0, LTE_FDD (0) Frequency: 2560 MHz Duty Cycle: 1:1

Probe: EX3DV4 – SN3633 ConvF (7.21, 7.21, 7.21);

Rear Side High 1RB_Mid /Area Scan (71x61x1): Interpolated grid: dx=1.500 mm, dy=1.500 mm

Maximum value of SAR (interpolated) = 1.20 W/kg

Rear Side High 1RB_Mid/Zoom Scan (5x5x7)/Cube 0: Measurement grid: dx=8mm, dy=8mm, dz=5mm

Reference Value = 0 V/m; Power Drift = 0.07 dB

Peak SAR (extrapolated) = 2.38 W/kg

SAR(1 g) = 0.938 W/kg; SAR(10 g) = 0.319 W/kg

Maximum value of SAR (measured) = 1.42 W/kg

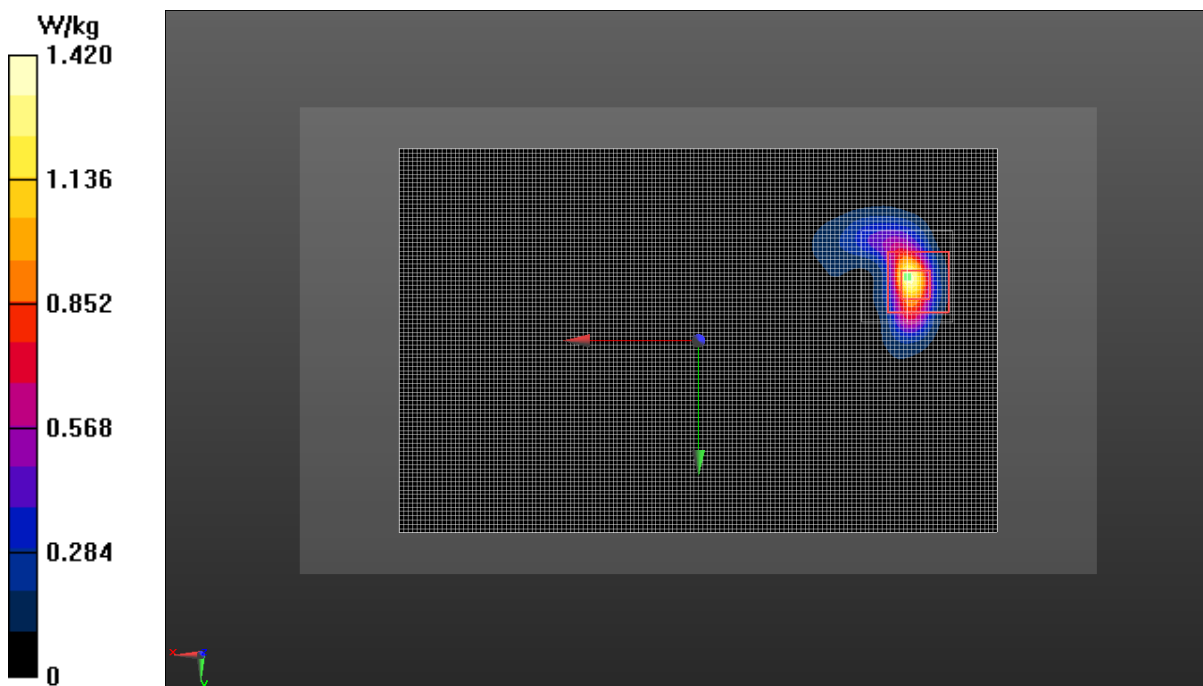

Fig.8 LTE Band 7

LTE Band 12 Body

Date: 2019-3-17

Electronics: DAE4 Sn786

Medium: Body 750 MHz

Medium parameters used: $f = 704 \text{ MHz}$; $\sigma = 0.973 \text{ S/m}$; $\epsilon_r = 55.151$; $\rho = 1000 \text{ kg/m}^3$

Ambient Temperature: 22.0°C Liquid Temperature: 21.5°C

Communication System: UID 0, LTE_FDD (0) Frequency: 704 MHz Duty Cycle: 1:1

Probe: EX3DV4 – SN3633 ConvF (9.56, 9.56, 9.56);

Rear Side Low 1RB_Mid/Area Scan (141x81x1): Interpolated grid: $dx=1.500 \text{ mm}$, $dy=1.500 \text{ mm}$

Maximum value of SAR (interpolated) = 0.874 W/kg

Rear Side Low 1RB_Mid/Zoom Scan (5x5x7)/Cube 0: Measurement grid: $dx=8\text{mm}$, $dy=8\text{mm}$, $dz=5\text{mm}$

Reference Value = 9.585 V/m ; Power Drift = 0.04 dB

Peak SAR (extrapolated) = 1.86 W/kg

SAR(1 g) = 0.747 W/kg ; SAR(10 g) = 0.406 W/kg

Maximum value of SAR (measured) = 1.23 W/kg

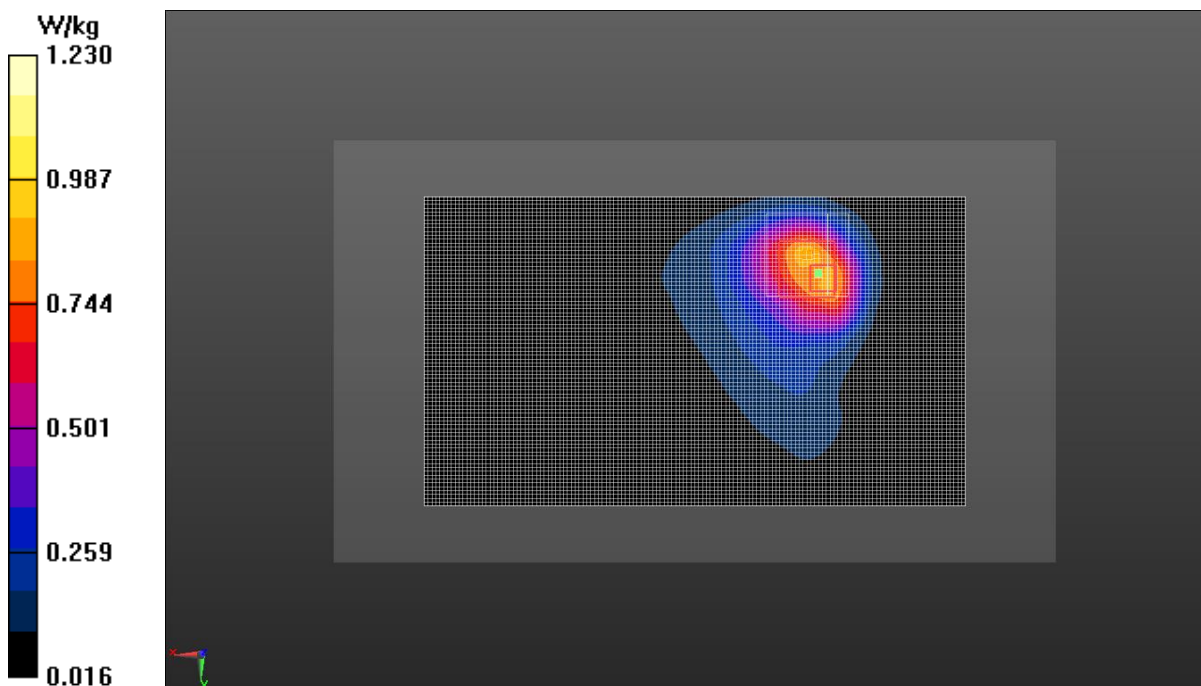

Fig.9 LTE Band 12

LTE Band 66 Body

Date: 2019-3-14

Electronics: DAE4 Sn786

Medium: Body 1750 MHz

Medium parameters used: $f = 1770$ MHz; $\sigma = 1.477$ S/m; $\epsilon_r = 53.334$; $\rho = 1000$ kg/m³

Ambient Temperature: 22.0°C Liquid Temperature: 21.5°C

Communication System: UID 0, LTE_FDD (0) Frequency: 1770 MHz Duty Cycle: 1:1

Probe: EX3DV4 – SN3633 ConvF (7.93, 7.93, 7.93);

Rear Side High 50RB_Low/Area Scan (51x51x1): Interpolated grid: dx=1.500 mm, dy=1.500 mm

Maximum value of SAR (interpolated) = 0.707 W/kg

Rear Side High 50RB_Low/Zoom Scan (5x5x7)/Cube 0: Measurement grid: dx=8mm, dy=8mm, dz=5mm

Reference Value = 2.156 V/m; Power Drift = 0.03 dB

Peak SAR (extrapolated) = 1.87 W/kg

SAR(1 g) = 0.822 W/kg; SAR(10 g) = 0.326 W/kg

Maximum value of SAR (measured) = 1.08 W/kg

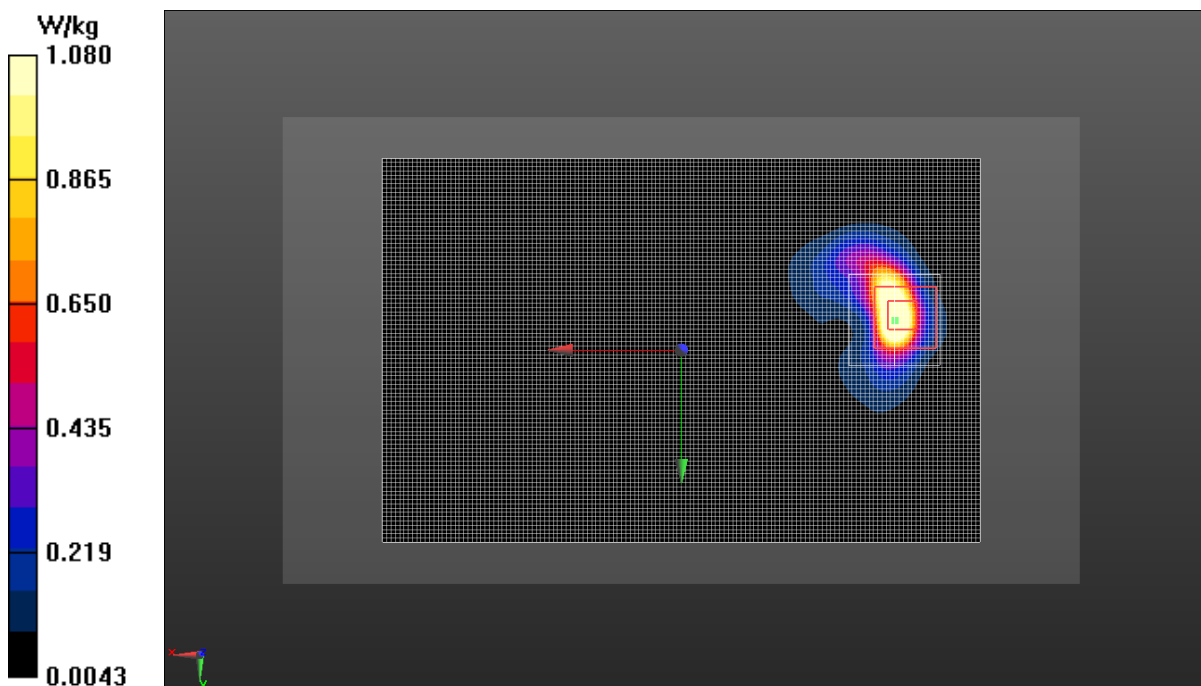

Fig.10 LTE Band 66

LTE Band 71 Body

Date: 2019-3-17

Electronics: DAE4 Sn786

Medium: Body 750 MHz

Medium parameters used: $f = 683 \text{ MHz}$; $\sigma = 0.960 \text{ S/m}$; $\epsilon_r = 55.266$; $\rho = 1000 \text{ kg/m}^3$

Ambient Temperature: 22.0°C Liquid Temperature: 21.5°C

Communication System: UID 0, LTE_FDD (0) Frequency: 683 MHz Duty Cycle: 1:1

Probe: EX3DV4 – SN3633 ConvF (9.56, 9.56, 9.56);

Rear Side Middle 1RB_Mid/Area Scan (61x61x1): Interpolated grid: $dx=1.500 \text{ mm}$, $dy=1.500 \text{ mm}$

Maximum value of SAR (interpolated) = 1.05 W/kg

Rear Side Middle 1RB_Mid/Zoom Scan (5x5x7)/Cube 0: Measurement grid: $dx=8\text{mm}$, $dy=8\text{mm}$, $dz=5\text{mm}$

Reference Value = 7.006 V/m; Power Drift = 0.08 dB

Peak SAR (extrapolated) = 1.58 W/kg

SAR(1 g) = 0.590 W/kg; SAR(10 g) = 0.306 W/kg

Maximum value of SAR (measured) = 0.693 W/kg

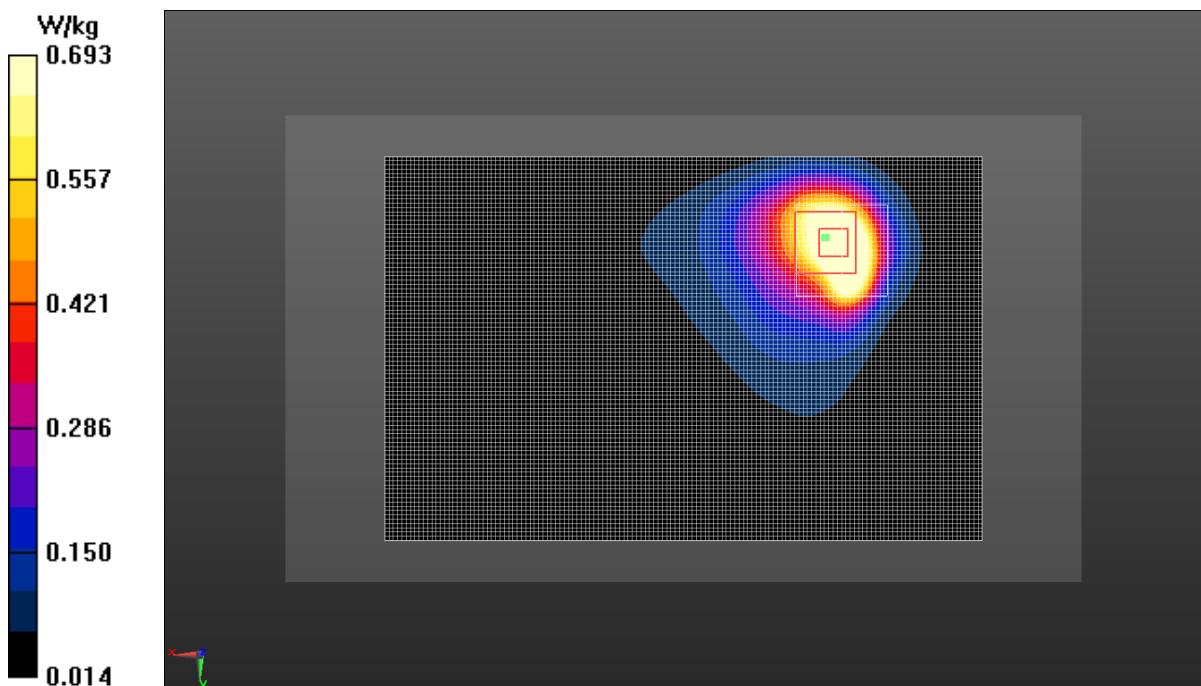

Fig.11 LTE Band 71

Wi-Fi 2.4G Body

Date: 2019-3-23

Electronics: DAE4 Sn786

Medium: Body 2450 MHz

Medium parameters used (interpolated): $f = 2437$ MHz; $\sigma = 1.911$ S/m; $\epsilon_r = 50.568$; $\rho = 1000$ kg/m³

Ambient Temperature: 22.0°C Liquid Temperature: 21.5°C

Communication System: UID 0, WiFi (0) Frequency: 2437 MHz Duty Cycle: 1:1

Probe: EX3DV4 – SN3633 ConvF (7.4, 7.4, 7.4);

Top Side Middle/Area Scan (41x101x1): Interpolated grid: dx=1.500 mm, dy=1.500 mm

Maximum value of SAR (interpolated) = 0.518 W/kg

Top Side Middle/Zoom Scan (7x7x7)/Cube 0: Measurement grid: dx=5mm, dy=5mm, dz=5mm

Reference Value = 10.85 V/m; Power Drift = 0.08 dB

Peak SAR (extrapolated) = 0.740 W/kg

SAR(1 g) = 0.376 W/kg; SAR(10 g) = 0.183 W/kg

Maximum value of SAR (measured) = 0.564 W/kg

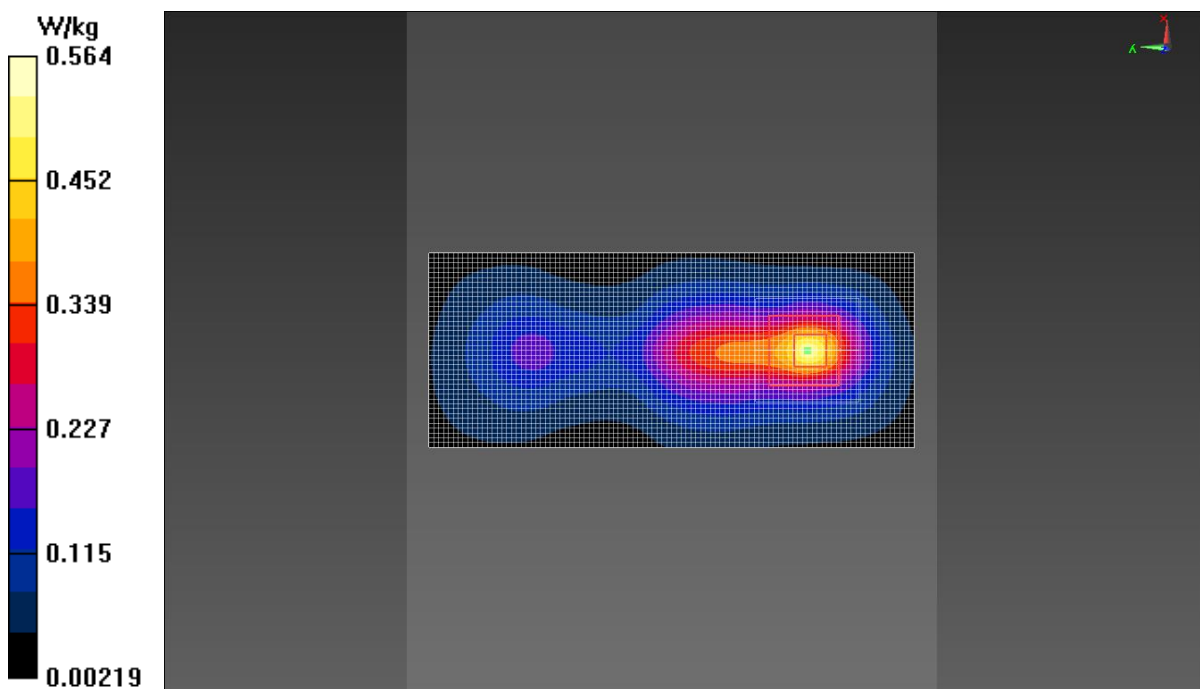

Fig.12 Wi-Fi 2.4G

Wi-Fi 5G Body

Date: 2019-3-26

Electronics: DAE4 Sn786

Medium: Body 5800 MHz

Medium parameters used: $f = 5745$ MHz; $\sigma = 6.059$ S/m; $\epsilon_r = 47.811$; $\rho = 1000$ kg/m³

Ambient Temperature: 22.0°C Liquid Temperature: 21.5°C

Communication System: UID 0, WiFi 5G (0) Frequency: 5745 MHz Duty Cycle: 1:1

Probe: EX3DV4 – SN3633 ConvF (4.29, 4.29, 4.29);

Rear Side CH149/Area Scan (151x101x1): Interpolated grid: dx=1.000 mm, dy=1.000 mm

Maximum value of SAR (interpolated) = 0.455 W/kg

Rear Side CH149/Zoom Scan (7x7x7)/Cube 0: Measurement grid: dx=5mm, dy=5mm, dz=5mm

Reference Value = 2.248 V/m; Power Drift = 0.09 dB

Peak SAR (extrapolated) = 0.984 W/kg

SAR(1 g) = 0.368 W/kg; SAR(10 g) = 0.138 W/kg

Maximum value of SAR (measured) = 0.729 W/kg

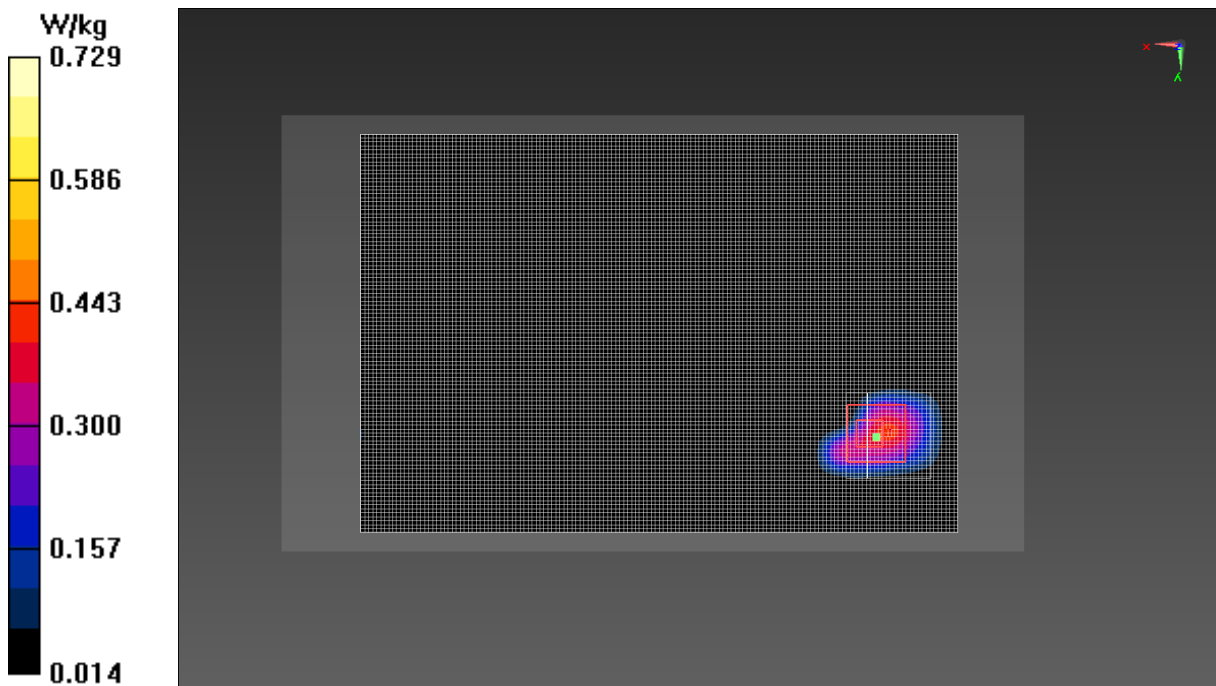

Fig.13 Wi-Fi 5G

ANNEX B SystemVerification Results

750MHz

Date: 2019-3-17

Electronics: DAE4 Sn786

Medium: Body 750 MHz

Medium parameters used: $f = 750 \text{ MHz}$; $\sigma = 1.001 \text{ S/m}$; $\epsilon_r = 54.892$; $\rho = 1000 \text{ kg/m}^3$

Ambient Temperature: 22.5°C Liquid Temperature: 22.0°C

Communication System: CW Frequency: 750 MHz Duty Cycle: 1:1

Probe: EX3DV4 – SN3633 ConvF (9.56, 9.56, 9.56);

System Validation /Area Scan (81x191x1): Interpolated grid: $dx=1.000 \text{ mm}$, $dy=1.000 \text{ mm}$

Reference Value = 58.842 V/m ; Power Drift = 0.02 dB

SAR(1 g) = 2.18 W/kg; SAR(10 g) = 1.42 W/kg

Maximum value of SAR (interpolated) = 2.48 W/kg

System Validation /Zoom Scan (7x7x7)/Cube 0: Measurement grid: $dx=5\text{mm}$, $dy=5\text{mm}$, $dz=5\text{mm}$

Reference Value = 58.842 V/m ; Power Drift = 0.02 dB

Peak SAR (extrapolated) = 2.75 W/kg

SAR(1 g) = 2.22 W/kg; SAR(10 g) = 1.44 W/kg

Maximum value of SAR (measured) = 2.51 W/kg

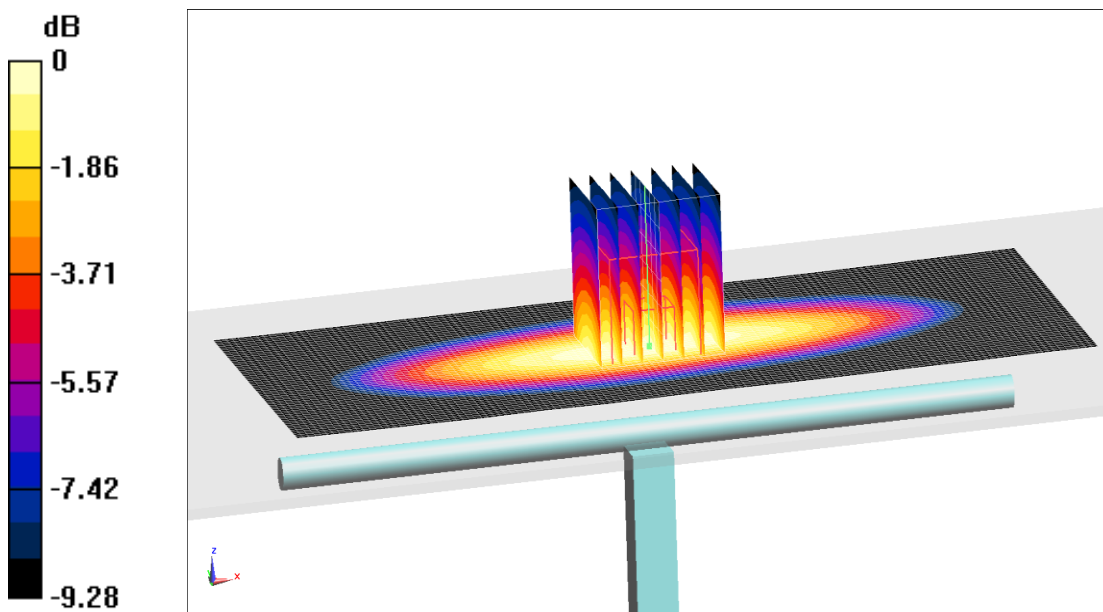

0 dB = 2.51 W/kg = 4.00 dB W/kg

Fig.B.1. Validation 750MHz 250mW

835MHz

Date: 2019-3-19

Electronics: DAE4 Sn786

Medium: Body 835 MHz

Medium parameters used: $f = 835 \text{ MHz}$; $\sigma = 0.989 \text{ S/m}$; $\epsilon_r = 52.694$; $\rho = 1000 \text{ kg/m}^3$

Ambient Temperature: 22.5°C Liquid Temperature: 22.0°C

Communication System: CW Frequency: 835 MHz Duty Cycle: 1:1

Probe: EX3DV4 – SN3633 ConvF (9.56, 9.56, 9.56);

System Validation /Area Scan (81x171x1): Interpolated grid: $dx=1.000 \text{ mm}$, $dy=1.000 \text{ mm}$

Reference Value = 61.309 V/m ; Power Drift = -0.05 dB

SAR(1 g) = 2.60 W/kg ; SAR(10 g) = 1.69 W/kg

Maximum value of SAR (interpolated) = 2.83 W/kg

System Validation /Zoom Scan (7x7x7)/Cube 0: Measurement grid: $dx=5\text{mm}$, $dy=5\text{mm}$, $dz=5\text{mm}$

Reference Value = 61.309 V/m ; Power Drift = -0.05 dB

Peak SAR (extrapolated) = 3.62 W/kg

SAR(1 g) = 2.56 W/kg ; SAR(10 g) = 1.67 W/kg

Maximum value of SAR (measured) = 2.76 W/kg

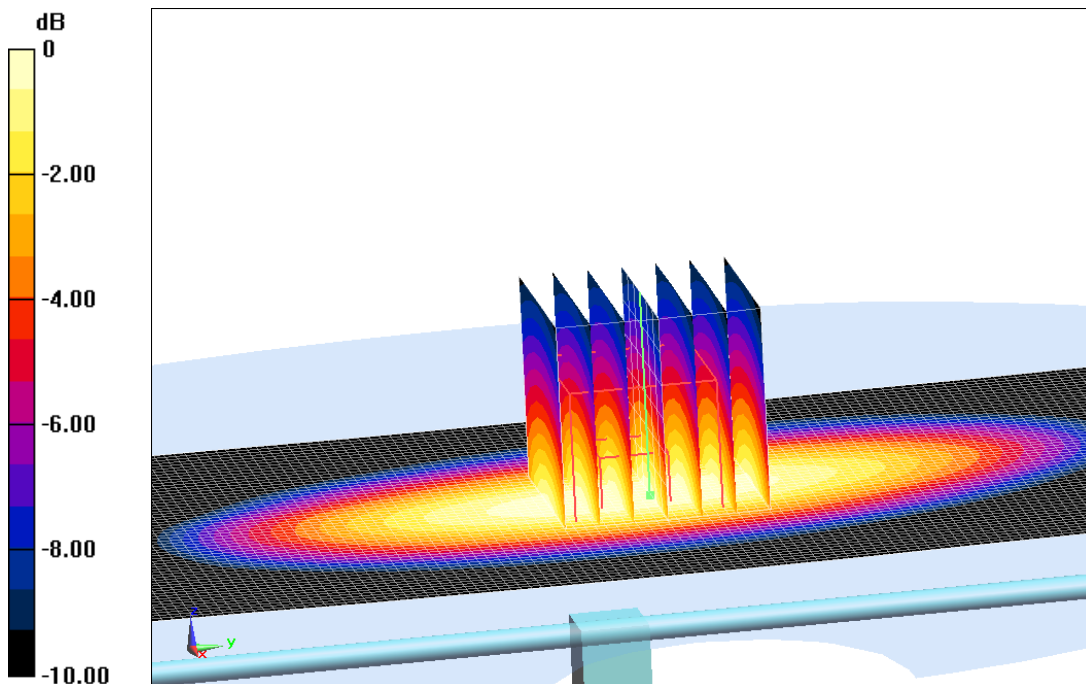

0 dB = 2.76 W/kg = 4.41 dB W/kg

Fig.B.2. Validation 835MHz 250mW

1750MHz

Date: 2019-3-14

Electronics: DAE4 Sn786

Medium: Body 1750 MHz

Medium parameters used: $f = 1750$ MHz; $\sigma = 1.458$ S/m; $\epsilon_r = 53.391$; $\rho = 1000$ kg/m³

Ambient Temperature: 22.0°C Liquid Temperature: 21.5°C

Communication System: CW Frequency: 1750 MHz Duty Cycle: 1:1

Probe: EX3DV4 – SN3633 ConvF (7.93, 7.93, 7.93);

System Validation/Area Scan (61x121x1): Interpolated grid: dx=1.000 mm, dy=1.000 mm

Reference Value = 76.112 V/m; Power Drift = -0.10 dB

SAR(1 g) = 8.91 W/kg; SAR(10 g) = 4.84 W/kg

Maximum value of SAR (interpolated) = 11.7 W/kg

System Validation/Zoom Scan (7x7x7)/Cube 0: Measurement grid: dx=5mm, dy=5mm, dz=5mm

Reference Value = 76.112 V/m; Power Drift = -0.10 dB

Peak SAR (extrapolated) = 18.1 W/kg

SAR(1 g) = 8.73 W/kg; SAR(10 g) = 4.78 W/kg

Maximum value of SAR (measured) = 11.2 W/kg

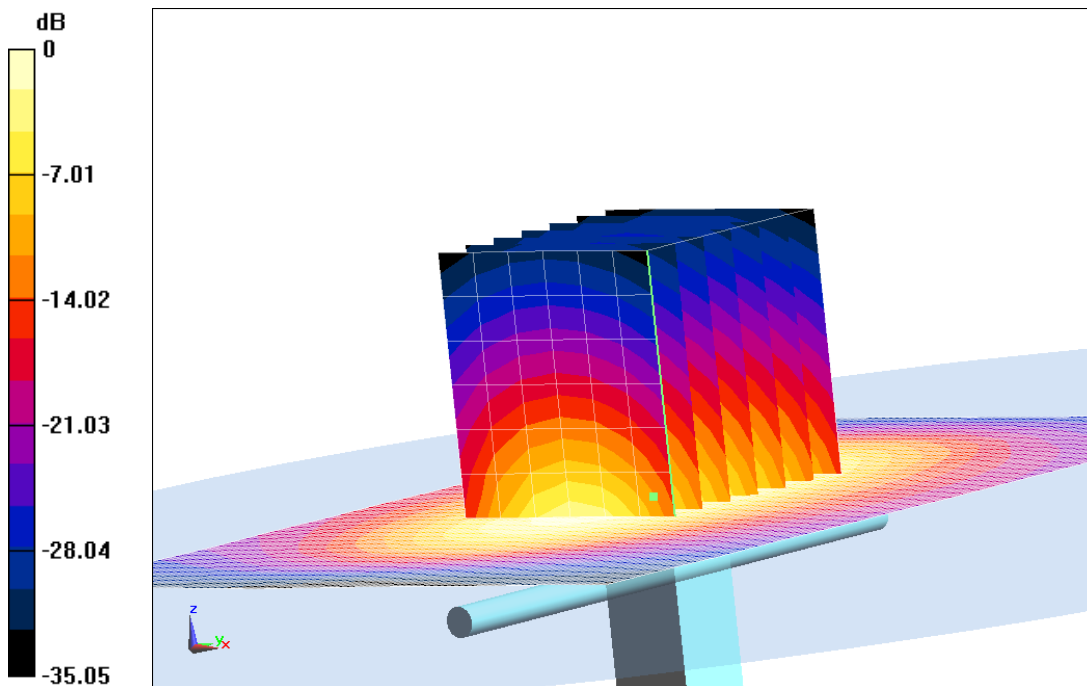

0 dB = 11.2 W/kg = 10.49 dB W/kg

Fig.B.3. Validation 1750MHz 250mW

1900MHz

Date: 2019-3-24

Electronics: DAE4 Sn786

Medium: Body 1900 MHz

Medium parameters used: $f = 1900 \text{ MHz}$; $\sigma = 1.574 \text{ S/m}$; $\epsilon_r = 52.954$; $\rho = 1000 \text{ kg/m}^3$

Ambient Temperature: 22.9°C Liquid Temperature: 22.5°C

Communication System: CW Frequency: 1900 MHz Duty Cycle: 1:1

Probe: EX3DV4 – SN3633 ConvF (7.67, 7.67, 7.67);

System validation /Area Scan (81x121x1): Interpolated grid: $dx=1.000 \text{ mm}$, $dy=1.000 \text{ mm}$

Reference Value = 89.214 V/m ; Power Drift = 0.08 dB

SAR(1 g) = 10.4 W/kg ; SAR(10 g) = 5.42 W/kg

Maximum value of SAR (interpolated) = 13.4 W/kg

System validation /Zoom Scan (7x7x7)/Cube 0: Measurement grid: $dx=5\text{mm}$, $dy=5\text{mm}$, $dz=5\text{mm}$

Reference Value = 89.214 V/m ; Power Drift = 0.08 dB

Peak SAR (extrapolated) = 23.9 W/kg

SAR(1 g) = 10.6 W/kg ; SAR(10 g) = 5.49 W/kg

Maximum value of SAR (measured) = 13.8 W/kg

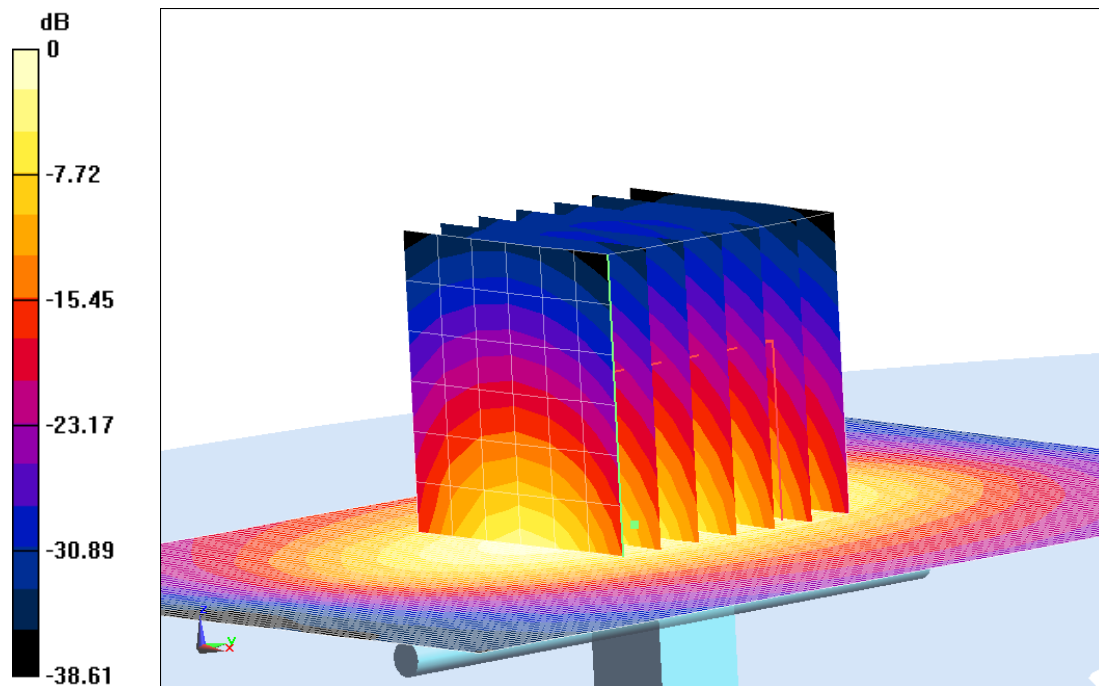

$0 \text{ dB} = 13.8 \text{ W/kg} = 11.40 \text{ dB W/kg}$

Fig.B.4. Validation 1900MHz 250mW

2450MHz

Date: 2019-3-23

Electronics: DAE4 Sn786

Medium: Body 2450 MHz

Medium parameters used: $f = 2450 \text{ MHz}$; $\sigma = 1.928 \text{ S/m}$; $\epsilon_r = 50.533$; $\rho = 1000 \text{ kg/m}^3$

Ambient Temperature: 22.0°C Liquid Temperature: 21.6°C

Communication System: CW Frequency: 2450 MHz Duty Cycle: 1:1

Probe: EX3DV4 – SN3633 ConvF (7.33, 7.33, 7.33);

System Validation/Area Scan (81x101x1): Interpolated grid: $dx=1.000 \text{ mm}$, $dy=1.000 \text{ mm}$

Reference Value = 89.742 V/m ; Power Drift = -0.04 dB

SAR(1 g) = 12.3 W/kg ; SAR(10 g) = 5.81 W/kg

Maximum value of SAR (interpolated) = 15.1 W/kg

System Validation/Zoom Scan (7x7x7)/Cube 0: Measurement grid: $dx=5\text{mm}$, $dy=5\text{mm}$, $dz=5\text{mm}$

Reference Value = 89.742 V/m ; Power Drift = -0.04 dB

Peak SAR (extrapolated) = 25.3 W/kg

SAR(1 g) = 12.1 W/kg ; SAR(10 g) = 5.73 W/kg

Maximum value of SAR (measured) = 14.7 W/kg

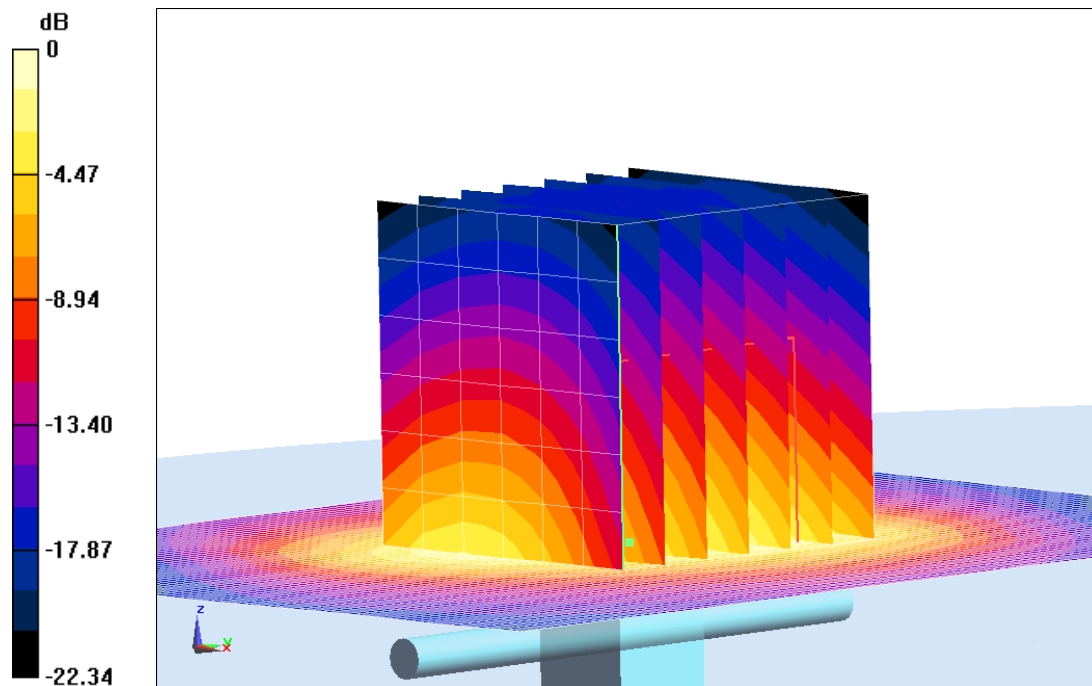

0 dB = 14.7 W/kg = 11.67 dB W/kg

Fig.B.5. Validation 2450MHz 250mW

2550MHz

Date: 2019-3-20

Electronics: DAE4 Sn786

Medium: Body 2550 MHz

Medium parameters used: $f = 2550 \text{ MHz}$; $\sigma = 2.052 \text{ S/m}$; $\epsilon_r = 52.208$; $\rho = 1000 \text{ kg/m}^3$

Ambient Temperature: 22.0°C Liquid Temperature: 21.6°C

Communication System: CW Frequency: 2550 MHz Duty Cycle: 1:1

Probe: EX3DV4 – SN3633 ConvF (7.21, 7.21, 7.21);

System Validation/Area Scan (81x101x1): Interpolated grid: $dx=1.000 \text{ mm}$, $dy=1.000 \text{ mm}$

Reference Value = 90.558 V/m ; Power Drift = -0.11 dB

SAR(1 g) = 13.3 W/kg ; SAR(10 g) = 6.17 W/kg

Maximum value of SAR (interpolated) = 15.5 W/kg

System Validation/Zoom Scan (7x7x7)/Cube 0: Measurement grid: $dx=5\text{mm}$, $dy=5\text{mm}$, $dz=5\text{mm}$

Reference Value = 90.558 V/m ; Power Drift = -0.11 dB

Peak SAR (extrapolated) = 27.5 W/kg

SAR(1 g) = 13.0 W/kg ; SAR(10 g) = 6.05 W/kg

Maximum value of SAR (measured) = 15.3 W/kg

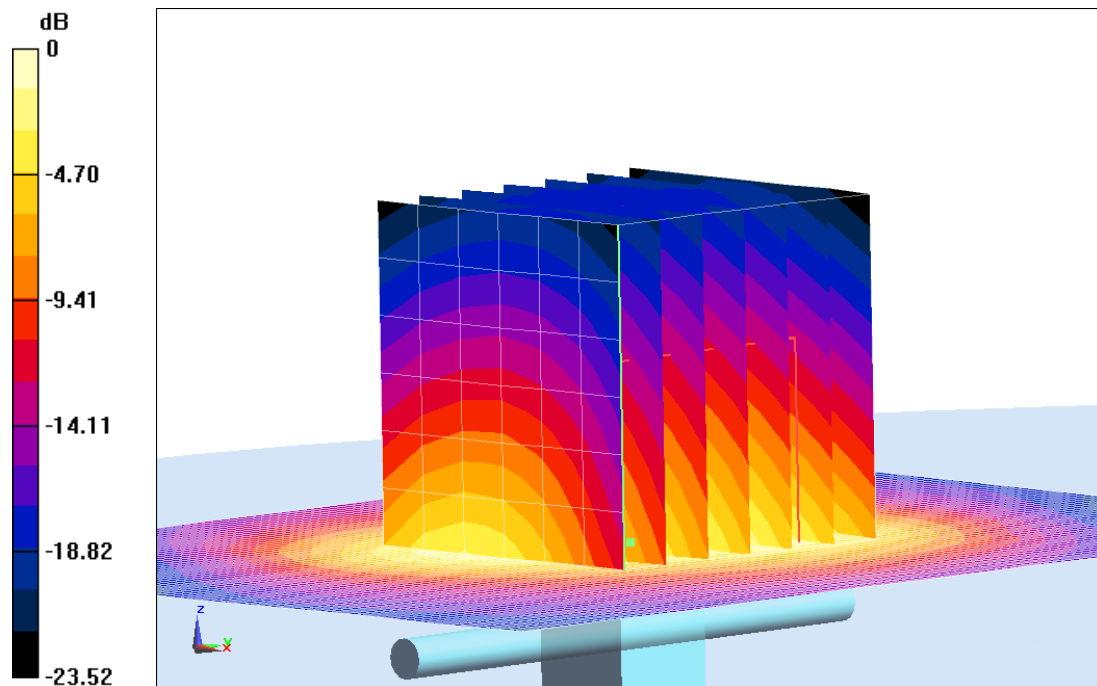

$0 \text{ dB} = 15.3 \text{ W/kg} = 11.85 \text{ dB W/kg}$

Fig.B.6. Validation 2550MHz 250mW

5300MHz

Date: 2019-3-26

Electronics: DAE4 Sn786

Medium: Body 5300 MHz

Medium parameters used: $f = 5300$ MHz; $\sigma = 5.474$ S/m; $\epsilon_r = 47.628$; $\rho = 1000$ kg/m³

Ambient Temperature: 23.0°C Liquid Temperature: 22.5°C

Communication System: CW Frequency: 5300 MHz Duty Cycle: 1:1

Probe: EX3DV4 - SN3633 ConvF (5.03, 5.03, 5.03);

System Validation /Area Scan (91x91x1): Interpolated grid: dx=1.000 mm, dy=1.000 mm

Reference Value = 57.216 V/m; Power Drift = 0.09 dB

SAR(1 g) = 7.66 W/kg; SAR(10 g) = 2.16 W/kg

Maximum value of SAR (interpolated) = 9.78 W/kg

System Validation/Zoom Scan (8x8x8)/Cube0: Measurement grid: dx=4mm, dy=4mm, dz=4mm

Reference Value = 57.216 V/m; Power Drift = 0.09 dB

Peak SAR (extrapolated) = 26.8 W/kg

SAR(1 g) = 7.83 W/kg; SAR(10 g) = 2.18 W/kg

Maximum value of SAR (measured) = 9.84 W/kg

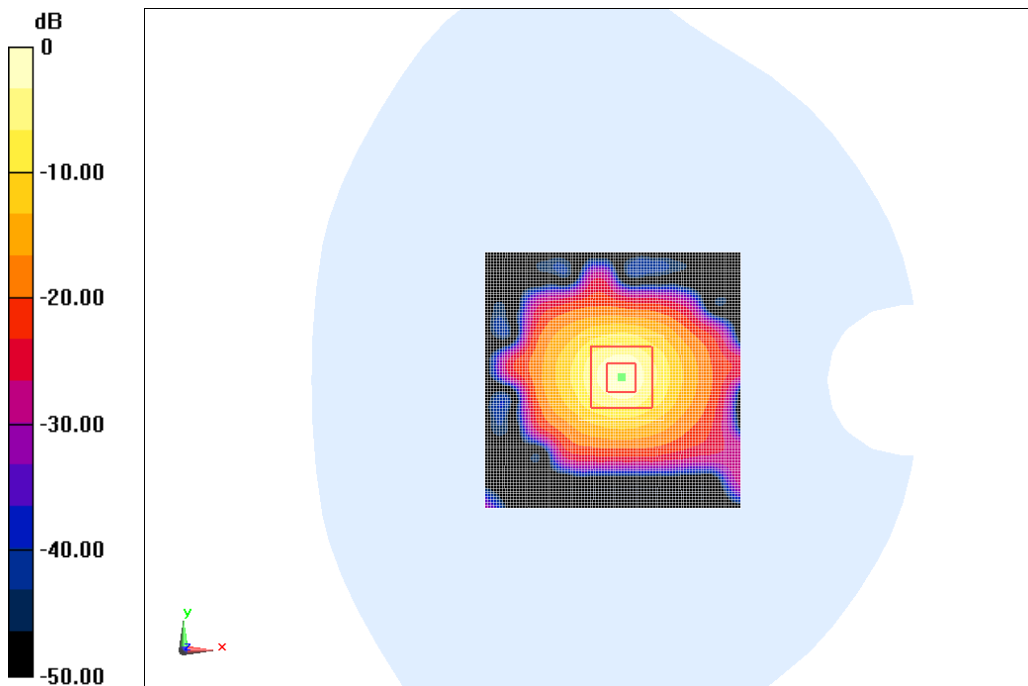

0 dB = 9.84 W/kg = 9.93 dB W/kg

Fig.B.7. validation 5300MHz 100mW

5800MHz

Date: 2019-3-26

Electronics: DAE4 Sn786

Medium: Body 5800 MHz

Medium parameters used: $f = 5800$ MHz; $\sigma = 6.202$ S/m; $\epsilon_r = 47.395$; $\rho = 1000$ kg/m³

Ambient Temperature: 23.0°C Liquid Temperature: 22.5°C

Communication System: CW Frequency: 5800 MHz Duty Cycle: 1:1

Probe: EX3DV4 - SN3633 ConvF (4.29, 4.29, 4.29);

System Validation/Area Scan (91x91x1): Interpolated grid: dx=1.000 mm, dy=1.000 mm

Reference Value = 58.238 V/m; Power Drift = 0.01 dB

SAR(1 g) = 7.75 W/kg; SAR(10 g) = 2.13 W/kg

Maximum value of SAR (interpolated) = 9.92 W/kg

System Validation/Zoom Scan (8x8x8)/Cube0: Measurement grid: dx=4mm, dy=4mm, dz=4mm

Reference Value = 58.238 V/m; Power Drift = 0.01 dB

Peak SAR (extrapolated) = 28.8 W/kg

SAR(1 g) = 7.87 W/kg; SAR(10 g) = 2.15 W/kg

Maximum value of SAR (measured) = 10.1 W/kg

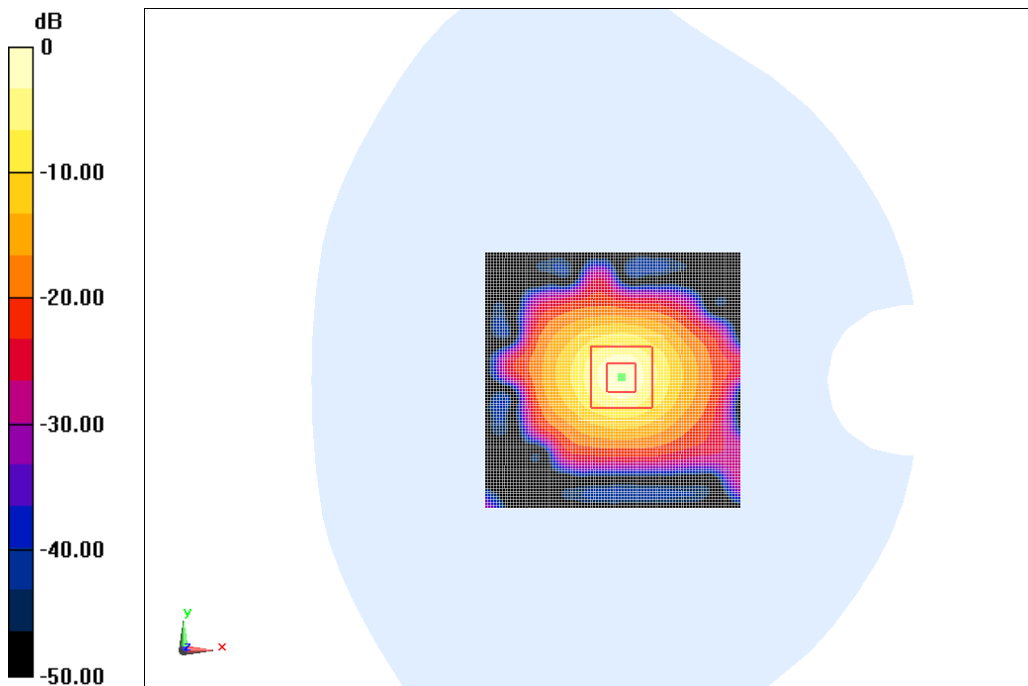

0 dB = 10.1 W/kg = 10.04 dB W/kg

Fig.B.8. Validation 5800MHz 100mW

ANNEX C SAR Measurement Setup

C.1 Measurement Set-up

DASY5 system for performing compliance tests is illustrated above graphically. This system consists of the following items:

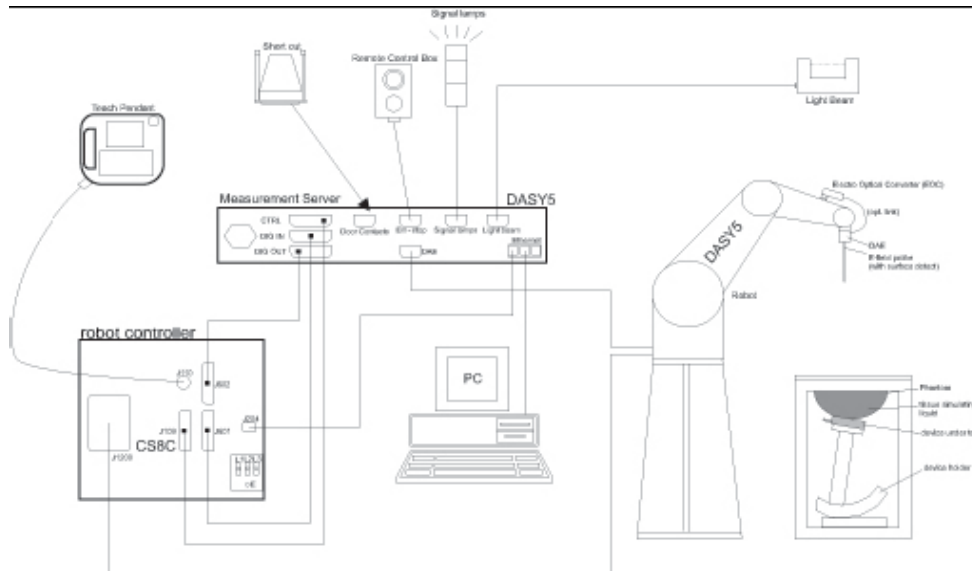

Picture C.1 SAR Lab Test Measurement Set-up

- A standard high precision 6-axis robot (Stäubli TX=RX family) with controller, teach pendant and software. An arm extension for accommodating the data acquisition electronics (DAE).
- An isotropic field probe optimized and calibrated for the targeted measurement.
- A data acquisition electronics (DAE) which performs the signal amplification, signal multiplexing, AD-conversion, offset measurements, mechanical surface detection, collision detection, etc. The unit is battery powered with standard or rechargeable batteries. The signal is optically transmitted to the EOC.
- The Electro-optical converter (EOC) performs the conversion from optical to electrical signals for the digital communication to the DAE. To use optical surface detection, a special version of the EOC is required. The EOC signal is transmitted to the measurement server.
- The function of the measurement server is to perform the time critical tasks such as signal filtering, control of the robot operation and fast movement interrupts.
- The Light Beam used is for probe alignment. This improves the (absolute) accuracy of the probe positioning.
- A computer running WinXP and the DASY5 software.
- Remote control and teach pendant as well as additional circuitry for robot safety such as
- warning lamps, etc.
- The phantom, the device holder and other accessories according to the targeted measurement.

C.2 DASY5 E-field Probe System

The SAR measurements were conducted with the dosimetric probe designed in the classical triangular configuration and optimized for dosimetric evaluation. The probe is constructed using the thick film technique; with printed resistive lines on ceramic substrates. The probe is equipped with an optical multifiber line ending at the front of the probe tip. It is connected to the EOC box on the robot arm and provides an automatic detection of the phantom surface. Half of the fibers are connected to a pulsed infrared transmitter, the other half to a synchronized receiver. As the probe approaches the surface, the reflection from the surface produces a coupling from the transmitting to the receiving fibers. This reflection increases first during the approach, reaches maximum and then decreases. If the probe is flatly touching the surface, the coupling is zero. The distance of the coupling maximum to the surface is independent of the surface reflectivity and largely independent of the surface to probe angle. The DASY5 software reads the reflection during a software approach and looks for the maximum using 2nd order curve fitting. The approach is stopped at reaching the maximum.

Probe Specifications:

Model:	ES3DV3, EX3DV4
Frequency	10MHz — 6.0GHz(EX3DV4)
Range:	10MHz — 4GHz(ES3DV3)
Calibration:	In head and body simulating tissue at Frequencies from 835 up to 5800MHz
Linearity:	± 0.2 dB(30 MHz to 6 GHz) for EX3DV4 ± 0.2 dB(30 MHz to 4 GHz) for ES3DV3
Dynamic Range:	10 mW/kg — 100W/kg
Probe Length:	330 mm
Probe Tip	
Length:	20 mm
Body Diameter:	12 mm
Tip Diameter:	2.5 mm (3.9 mm for ES3DV3)
Tip-Center:	1 mm (2.0mm for ES3DV3)
Application:	SAR Dosimetry Testing Compliance tests of mobile phones Dosimetry in strong gradient fields



Picture C.2 Near-field Probe



Picture C.3 E-field Probe

C.3 E-field Probe Calibration

Each E-Probe/Probe Amplifier combination has unique calibration parameters. A TEM cell calibration procedure is conducted to determine the proper amplifier settings to enter in the probe parameters. The amplifier settings are determined for a given frequency by subjecting the probe to a known E-field density (1 mW/cm^2) using an RF Signal generator, TEM cell, and RF Power Meter.

The free space E-field from amplified probe outputs is determined in a test chamber. This calibration can be performed in a TEM cell if the frequency is below 1 GHz and in a waveguide or

other methodologies above 1 GHz for free space. For the free space calibration, the probe is placed in the volumetric center of the cavity and at the proper orientation with the field. The probe is then rotated 360 degrees until the three channels show the maximum reading. The power density readings equates to 1 mW/ cm² :

E-field temperature correlation calibration is performed in a flat phantom filled with the appropriate simulated brain tissue. The E-field in the medium correlates with the temperature rise in the dielectric medium. For temperature correlation calibration a RF transparent thermistor-based temperature probe is used in conjunction with the E-field probe.

$$SAR = C \frac{\Delta T}{\Delta t}$$

Where:

Δt = Exposure time (30 seconds),

C = Heat capacity of tissue (brain or muscle),

ΔT = Temperature increase due to RF exposure.

$$SAR = \frac{|E|^2 \cdot \sigma}{\rho}$$

Where:

σ = Simulated tissue conductivity,

ρ = Tissue density (kg/m³).

C.4 Other Test Equipment

C.4.1 Data Acquisition Electronics (DAE)

The data acquisition electronics consist of a highly sensitive electrometer-grade preamplifier with auto-zeroing, a channel and gain-switching multiplexer, a fast 16 bit AD-converter and a command decoder with a control logic unit. Transmission to the measurement server is accomplished through an optical downlink for data and status information, as well as an optical uplink for commands and the clock.

The mechanical probe mounting device includes two different sensor systems for frontal and sideways probe contacts. They are used for mechanical surface detection and probe collision detection.

The input impedance of the DAE is 200 MOhm; the inputs are symmetrical and floating. Common mode rejection is above 80 dB.



PictureC.4: DAE

C.4.2 Robot

The SPEAG DASY system uses the high precision robots (DASY5: RX160L) type from Stäubli SA (France). For the 6-axis controller system, the robot controller version from Stäubli is used. The Stäubli robot series have many features that are important for our application:

- High precision (repeatability 0.02mm)
- High reliability (industrial design)
- Low maintenance costs (virtually maintenance free due to direct drive gears; no belt drives)
- Jerk-free straight movements (brushless synchron motors; no stepper motors)
- Low ELF interference (motor control fields shielded via the closed metallic construction shields)



Picture C.5 DASY 5

C.4.3 Measurement Server

The Measurement server is based on a PC/104 CPU board with CPU (DASY5: 400 MHz, Intel Celeron), chipdisk (DASY5:128MB), RAM (DASY5:128MB). The necessary circuits for communication with the DAE electronic box, as well as the 16 bit AD converter system for optical detection and digital I/O interface are contained on the DASY I/O board, which is directly connected to the PC/104 bus of the CPU board.

The measurement server performs all real-time data evaluation of field measurements and surface detection, controls robot movements and handles safety operation. The PC operating system cannot interfere with these time critical processes. All connections are supervised by a watchdog, and disconnection of any of the cables to the measurement server will automatically disarm the robot and disable all program-controlled robot movements. Furthermore, the measurement server is equipped with an expansion port which is reserved for future applications. Please note that this expansion port does not have a standardized pinout, and therefore only devices provided by SPEAG can be connected. Devices from any other supplier could seriously damage the measurement server.



Picture C.6 Server for DASY 5

C.4.4 Device Holder for Phantom

The SAR in the phantom is approximately inversely proportional to the square of the distance between the source and the liquid surface. For a source at 5mm distance, a positioning uncertainty of $\pm 0.5\text{mm}$ would produce a SAR uncertainty of $\pm 20\%$. Accurate device positioning is therefore crucial for accurate and repeatable measurements. The positions in which the devices must be measured are defined by the standards.

The DASY device holder is designed to cope with the different positions given in the standard. It has two scales for device rotation (with respect to the body axis) and device inclination (with respect to the line between the ear reference points). The rotation centers for both scales is the ear reference point (ERP). Thus the device needs no repositioning when changing the angles.

The DASY device holder is constructed of low-loss POM material having the following dielectric

parameters: relative permittivity $\epsilon = 3$ and loss tangent $\delta = 0.02$. The amount of dielectric material has been reduced in the closest vicinity of the device, since measurements have suggested that the influence of the clamp on the test results could thus be lowered.

<Laptop Extension Kit>

The extension is lightweight and made of POM, acrylic glass and foam. It fits easily on the upper part of the Mounting Device in place of the phone positioner. The extension is fully compatible with the Twin-SAM and ELI phantoms.



Picture C.7-1: Device Holder



Picture C.7-2: Laptop Extension Kit

C.4.5 Phantom

The SAM Twin Phantom V4.0 is constructed of a fiberglass shell integrated in a table. The shape of the shell is based on data from an anatomical study designed to represent the 90th percentile of the population. The phantom enables the dissymmetric evaluation of SAR for both left and right handed handset usage, as well as body-worn usage using the flat phantom region. Reference markings on the Phantom allow the complete setup of all predefined phantom positions and measurement grids by manually teaching three points in the robot. The shell phantom has a 2mm shell thickness (except the ear region where shell thickness increases to 6 mm).

Shell Thickness: 2 ± 0.2 mm
Filling Volume: Approx. 25 liters
Dimensions: 810 x 1000 x 500 mm (H x L x W)
Available: Special



Picture C.8: SAM Twin Phantom

ANNEX D Position of the wireless device in relation to the phantom

D.1 Body-worn device

A typical example of a body-worn device is a mobile phone, wireless enabled PDA or other battery operated wireless device with the ability to transmit while mounted on a person's body using a carry accessory approved by the wireless device manufacturer.

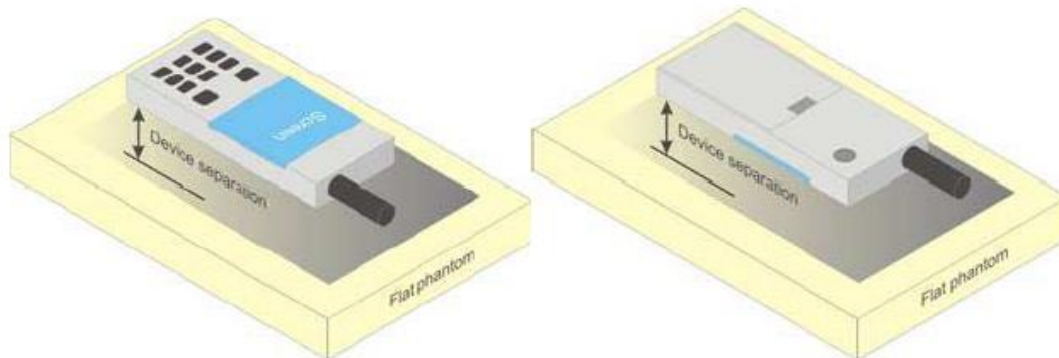

Picture D.1 Test positions for body-worn devices

D.2 Desktop device

A typical example of a desktop device is a wireless enabled desktop computer placed on a table or desk when used.

The DUT shall be positioned at the distance and in the orientation to the phantom that corresponds to the intended use as specified by the manufacturer in the user instructions. For devices that employ an external antenna with variable positions, tests shall be performed for all antenna positions specified. Picture 8.5 show positions for desktop device SAR tests. If the intended use is not specified, the device shall be tested directly against the flat phantom.

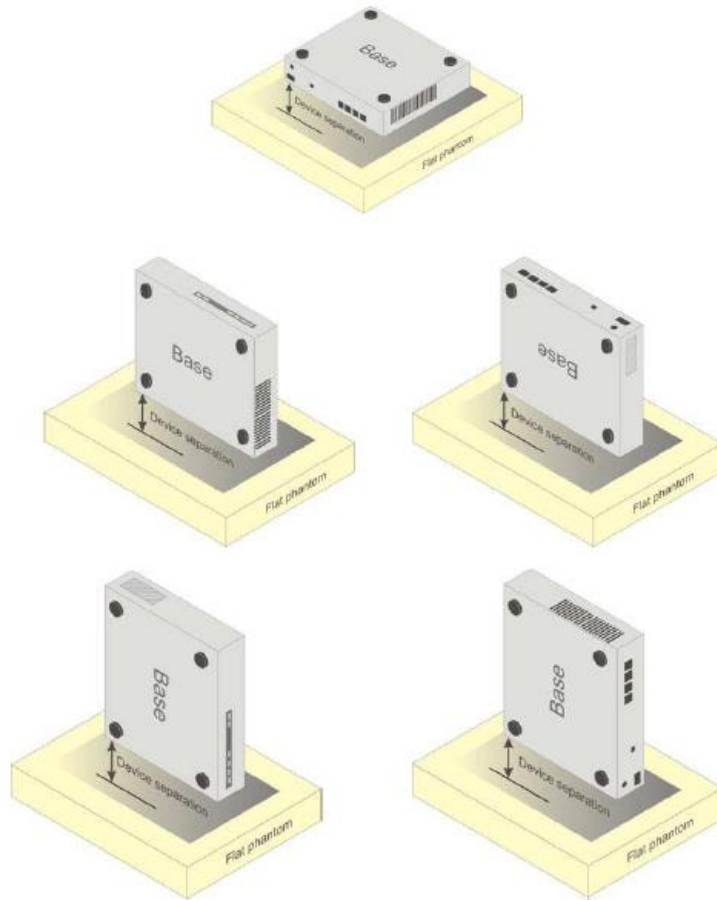

Picture D.2 Test positions for desktop devices

D.3 DUT Setup Photos



Picture D.3

ANNEX E Equivalent Media Recipes

The liquid used for the frequency range of 700-6000 MHz consisted of water, sugar, salt, preventol, glycol monobutyl and Cellulose. The liquid has been previously proven to be suited for worst-case. The Table E.1 shows the detail solution. It's satisfying the latest tissue dielectric parameters requirements proposed by the IEEE 1528 and IEC 62209.

Table E.1: Composition of the Tissue Equivalent Matter

Frequency (MHz)	835 Head	835 Body	1900 Head	1900 Body	2450 Head	2450 Body	5800 Head	5800 Body
Ingredients (% by weight)								
Water	41.45	52.5	55.242	69.91	58.79	72.60	65.53	65.53
Sugar	56.0	45.0	\	\	\	\	\	\
Salt	1.45	1.4	0.306	0.13	0.06	0.18	\	\
Preventol	0.1	0.1	\	\	\	\	\	\
Cellulose	1.0	1.0	\	\	\	\	\	\
Glycol Monobutyl	\	\	44.452	29.96	41.15	27.22	\	\
Diethylenglycol monohexylether	\	\	\	\	\	\	17.24	17.24
Triton X-100	\	\	\	\	\	\	17.24	17.24
Dielectric Parameters Target Value	$\epsilon=41.5$ $\sigma=0.90$	$\epsilon=55.2$ $\sigma=0.97$	$\epsilon=40.0$ $\sigma=1.40$	$\epsilon=53.3$ $\sigma=1.52$	$\epsilon=39.2$ $\sigma=1.80$	$\epsilon=52.7$ $\sigma=1.95$	$\epsilon=35.3$ $\sigma=5.27$	$\epsilon=48.2$ $\sigma=6.00$

Note: There is a little adjustment respectively for 750, 1800, 2600, 5200, 5300, and 5600, based on the recipe of closest frequency in table E.1

ANNEX F System Validation

The SAR system must be validated against its performance specifications before it is deployed. When SAR probes, system components or software are changed, upgraded or recalibrated, these must be validated with the SAR system(s) that operates with such components.

Table F.1: System Validation

Probe SN.	Liquid name	Validation date	Frequency point	Status (OK or Not)
3633	Head 750MHz	2019-03-02	750 MHz	OK
3633	Head 835MHz	2019-03-02	835 MHz	OK
3633	Head 1750MHz	2019-03-02	1800 MHz	OK
3633	Head 1900MHz	2019-03-02	1900 MHz	OK
3633	Head 2450MHz	2019-03-02	2450 MHz	OK
3633	Head 2550MHz	2019-03-02	2550 MHz	OK
3633	Head 5200MHz	2019-03-02	5200 MHz	OK
3633	Head 5300MHz	2019-03-02	5300 MHz	OK
3633	Head 5600MHz	2019-03-02	5600 MHz	OK
3633	Head 5800MHz	2019-03-02	5800 MHz	OK
3633	Body 750MHz	2019-03-03	750 MHz	OK
3633	Body 835MHz	2019-03-03	835 MHz	OK
3633	Body 1750MHz	2019-03-03	1800 MHz	OK
3633	Body 1900MHz	2019-03-03	1900 MHz	OK
3633	Body 2450MHz	2019-03-03	2450 MHz	OK
3633	Body 2550MHz	2019-03-03	5200 MHz	OK
3633	Body 5200MHz	2019-03-03	5200 MHz	OK
3633	Body 5300MHz	2019-03-03	5300 MHz	OK
3633	Body 5600MHz	2019-03-03	5600 MHz	OK
3633	Body 5800MHz	2019-03-03	5800 MHz	OK

ANNEX G DAE Calibration Certificate

DAE4 SN: 786 Calibration Certificate

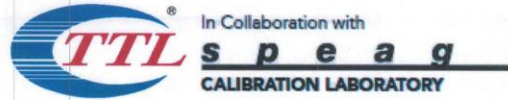

Add: No.51 Xueyuan Road, Haidian District, Beijing, 100191, China
Tel: +86-10-62304633-2512 Fax: +86-10-62304633-2504
E-mail: cttl@chinattl.com [Http://www.chinattl.cn](http://www.chinattl.cn)



中国认可
国际互认
校准
CALIBRATION
CNAS L0570

Client : **CTTL(South Branch)**

Certificate No: **Z19-60016**

CALIBRATION CERTIFICATE

Object: **DAE4 - SN: 786**

Calibration Procedure(s): **FF-Z11-002-01
Calibration Procedure for the Data Acquisition Electronics (DAEx)**

Calibration date: **January 11, 2019**

This calibration Certificate documents the traceability to national standards, which realize the physical units of measurements(SI). The measurements and the uncertainties with confidence probability are given on the following pages and are part of the certificate.

All calibrations have been conducted in the closed laboratory facility: environment temperature(22±3)°C and humidity<70%.

Calibration Equipment used (M&TE critical for calibration)

Primary Standards	ID #	Cal Date(Calibrated by, Certificate No.)	Scheduled Calibration
Process Calibrator 753	1971018	20-Jun-18 (CTTL, No.J18X05034)	June-19

	Name	Function	Signature
Calibrated by:	Yu Zongying	SAR Test Engineer	
Reviewed by:	Lin Hao	SAR Test Engineer	
Approved by:	Qi Dianyuan	SAR Project Leader	

Issued: January 14, 2019

This calibration certificate shall not be reproduced except in full without written approval of the laboratory.



Add: No.51 Xueyuan Road, Haidian District, Beijing, 100191, China
Tel: +86-10-62304633-2512 Fax: +86-10-62304633-2504
E-mail: cttl@chinattl.com Http://www.chinattl.cn

Glossary:

DAE data acquisition electronics
Connector angle information used in DASY system to align probe sensor X to the robot coordinate system.

Methods Applied and Interpretation of Parameters:

- *DC Voltage Measurement:* Calibration Factor assessed for use in DASY system by comparison with a calibrated instrument traceable to national standards. The figure given corresponds to the full scale range of the voltmeter in the respective range.
- *Connector angle:* The angle of the connector is assessed measuring the angle mechanically by a tool inserted. Uncertainty is not required.
- The report provide only calibration results for DAE, it does not contain other performance test results.



Add: No.51 Xueyuan Road, Haidian District, Beijing, 100191, China
Tel: +86-10-62304633-2512 Fax: +86-10-62304633-2504
E-mail: cttl@chinattl.com Http://www.chinattl.cn

DC Voltage Measurement

A/D - Converter Resolution nominal

High Range: 1LSB = 6.1 μ V, full range = -100...+300 mV

Low Range: 1LSB = 61nV, full range = -1.....+3mV

DASY measurement parameters: Auto Zero Time: 3 sec; Measuring time: 3 sec

Calibration Factors	X	Y	Z
High Range	404.064 \pm 0.15% (k=2)	404.247 \pm 0.15% (k=2)	404.629 \pm 0.15% (k=2)
Low Range	3.97273 \pm 0.7% (k=2)	3.97435 \pm 0.7% (k=2)	3.95858 \pm 0.7% (k=2)

Connector Angle

Connector Angle to be used in DASY system	229.5 $^{\circ}$ \pm 1 $^{\circ}$
---	-------------------------------------

ANNEX H Probe Calibration Certificate

Probe EX3DV4-SN: 3633 Calibration Certificate



Add: No.51 Xueyuan Road, Haidian District, Beijing, 100191, China
Tel: +86-10-62304633-2512 Fax: +86-10-62304633-2504
E-mail: ctl@chinattl.com [Http://www.chinattl.cn](http://www.chinattl.cn)



中国认可
国际互认
校准
CALIBRATION
CNAS L0570

Client **CTTL(South Branch)**

Certificate No: **Z19-60033**

CALIBRATION CERTIFICATE

Object EX3DV4 - SN:3633

Calibration Procedure(s) FF-Z11-004-01
Calibration Procedures for Dosimetric E-field Probes

Calibration date: February 26, 2019

This calibration Certificate documents the traceability to national standards, which realize the physical units of measurements(SI). The measurements and the uncertainties with confidence probability are given on the following pages and are part of the certificate.

All calibrations have been conducted in the closed laboratory facility: environment temperature(22±3)°C and humidity<70%.

Calibration Equipment used (M&TE critical for calibration)

Primary Standards	ID #	Cal Date(Calibrated by, Certificate No.)	Scheduled Calibration
Power Meter NRP2	101919	20-Jun-18 (CTTL, No.J18X05032)	Jun-19
Power sensor NRP-Z91	101547	20-Jun-18 (CTTL, No.J18X05032)	Jun-19
Power sensor NRP-Z91	101548	20-Jun-18 (CTTL, No.J18X05032)	Jun-19
Reference10dBAttenuator	18N50W-10dB	09-Feb-18(CTTL, No.J18X01133)	Feb-20
Reference20dBAttenuator	18N50W-20dB	09-Feb-18(CTTL, No.J18X01132)	Feb-20
Reference Probe EX3DV4	SN 7514	27-Aug-18(SPEAG,No.EX3-7514_Aug18/2)	Aug-19
DAE4	SN 1555	20-Aug-18(SPEAG, No.DAE4-1555_Aug18)	Aug -19
Secondary Standards	ID #	Cal Date(Calibrated by, Certificate No.)	Scheduled Calibration
SignalGeneratorMG3700A	6201052605	21-Jun-18 (CTTL, No.J18X05033)	Jun-19
Network Analyzer E5071C	MY46110673	24-Jan-18 (CTTL, No.J18X00561)	Jan -19

	Name	Function	Signature
Calibrated by:	Yu Zongying	SAR Test Engineer	
Reviewed by:	Lin Hao	SAR Test Engineer	
Approved by:	Qi Dianyuan	SAR Project Leader	

Issued: February 28, 2019

This calibration certificate shall not be reproduced except in full without written approval of the laboratory.

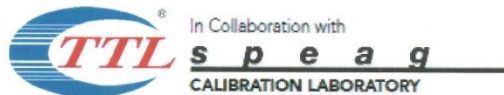

Add: No.51 Xueyuan Road, Haidian District, Beijing, 100191, China
Tel: +86-10-62304633-2512 Fax: +86-10-62304633-2504
E-mail: cttl@chinattl.com [Http://www.chinattl.cn](http://www.chinattl.cn)

Glossary:

TSL	tissue simulating liquid
NORM _{x,y,z}	sensitivity in free space
ConvF	sensitivity in TSL / NORM _{x,y,z}
DCP	diode compression point
CF	crest factor (1/duty_cycle) of the RF signal
A,B,C,D	modulation dependent linearization parameters
Polarization Φ	Φ rotation around probe axis
Polarization θ	θ rotation around an axis that is in the plane normal to probe axis (at measurement center), i $\theta=0$ is normal to probe axis

Connector Angle information used in DASY system to align probe sensor X to the robot coordinate system

Calibration is Performed According to the Following Standards:

- IEEE Std 1528-2013, "IEEE Recommended Practice for Determining the Peak Spatial-Averaged Specific Absorption Rate (SAR) in the Human Head from Wireless Communications Devices: Measurement Techniques", June 2013
- IEC 62209-1, "Measurement procedure for the assessment of Specific Absorption Rate (SAR) from hand-held and body-mounted devices used next to the ear (frequency range of 300 MHz to 6 GHz)", July 2016
- IEC 62209-2, "Procedure to determine the Specific Absorption Rate (SAR) for wireless communication devices used in close proximity to the human body (frequency range of 30 MHz to 6 GHz)", March 2010
- KDB 865664, "SAR Measurement Requirements for 100 MHz to 6 GHz"

Methods Applied and Interpretation of Parameters:

- NORM_{x,y,z}:** Assessed for E-field polarization $\theta=0$ ($f \leq 900\text{MHz}$ in TEM-cell; $f > 1800\text{MHz}$: waveguide). NORM_{x,y,z} are only intermediate values, i.e., the uncertainties of NORM_{x,y,z} does not effect the E^2 -field uncertainty inside TSL (see below ConvF).
- NORM(f)_{x,y,z} = NORM_{x,y,z} * frequency_response** (see Frequency Response Chart). This linearization is implemented in DASY4 software versions later than 4.2. The uncertainty of the frequency response is included in the stated uncertainty of ConvF.
- DCP_{x,y,z}:** DCP are numerical linearization parameters assessed based on the data of power sweep (no uncertainty required). DCP does not depend on frequency nor media.
- PAR:** PAR is the Peak to Average Ratio that is not calibrated but determined based on the signal characteristics.
- A_{x,y,z}; B_{x,y,z}; C_{x,y,z}; VR_{x,y,z}; A,B,C** are numerical linearization parameters assessed based on the data of power sweep for specific modulation signal. The parameters do not depend on frequency nor media. VR is the maximum calibration range expressed in RMS voltage across the diode.
- ConvF and Boundary Effect Parameters:** Assessed in flat phantom using E-field (or Temperature Transfer Standard for $f \leq 800\text{MHz}$) and inside waveguide using analytical field distributions based on power measurements for $f > 800\text{MHz}$. The same setups are used for assessment of the parameters applied for boundary compensation (alpha, depth) of which typical uncertainty valued are given. These parameters are used in DASY4 software to improve probe accuracy close to the boundary. The sensitivity in TSL corresponds to NORM_{x,y,z} * ConvF whereby the uncertainty corresponds to that given for ConvF. A frequency dependent ConvF is used in DASY version 4.4 and higher which allows extending the validity from $\pm 50\text{MHz}$ to $\pm 100\text{MHz}$.
- Spherical isotropy (3D deviation from isotropy):** in a field of low gradients realized using a flat phantom exposed by a patch antenna.
- Sensor Offset:** The sensor offset corresponds to the offset of virtual measurement center from the probe tip (on probe axis). No tolerance required.
- Connector Angle:** The angle is assessed using the information gained by determining the NORM_x (no uncertainty required).



Add: No.51 Xueyuan Road, Haidian District, Beijing, 100191, China
Tel: +86-10-62304633-2512 Fax: +86-10-62304633-2504
E-mail: ctl@chinattl.com [Http://www.chinattl.cn](http://www.chinattl.cn)

Probe EX3DV4

SN: 3633

Calibrated: February 26, 2019

Calibrated for DASY/EASY Systems

(Note: non-compatible with DASY2 system!)



Add: No.51 Xueyuan Road, Haidian District, Beijing, 100191, China
Tel: +86-10-62304633-2512 Fax: +86-10-62304633-2504
E-mail: ctl@chinattl.com [Http://www.chinattl.cn](http://www.chinattl.cn)

DASY/EASY – Parameters of Probe: EX3DV4 – SN: 3633

Basic Calibration Parameters

	Sensor X	Sensor Y	Sensor Z	Unc (k=2)
Norm($\mu\text{V}/(\text{V}/\text{m})^2$) ^A	0.39	0.37	0.39	$\pm 10.0\%$
DCP(mV) ^B	97.3	98.8	98.6	

Modulation Calibration Parameters

UID	Communication System Name		A dB	B dB· μV	C	D dB	VR mV	Unc ^E (k=2)
0	CW	X	0.0	0.0	1.0	0.00	144.3	$\pm 2.0\%$
		Y	0.0	0.0	1.0		145.2	
		Z	0.0	0.0	1.0		147.9	

The reported uncertainty of measurement is stated as the standard uncertainty of Measurement multiplied by the coverage factor k=2, which for a normal distribution Corresponds to a coverage probability of approximately 95%.

^A The uncertainties of Norm X, Y, Z do not affect the E²-field uncertainty inside TSL (see Page 5 and Page 6).

^B Numerical linearization parameter: uncertainty not required.

^E Uncertainty is determined using the max. deviation from linear response applying rectangular distribution and is expressed for the square of the field value.