



FCC PART 15C TEST REPORT No.I19Z62252-IOT07

for

Client name: TCL Communication Ltd.

Product name: LTE Mobile WiFi Router

Model name: MW43TM

With

FCC ID: 2ACCJB117

Hardware Version: 03

Software Version: MW43_ZZ_02.00_01

Issued Date: 2020-02-19

Note:

The test results in this test report relate only to the devices specified in this report. This report shall not be reproduced except in full without the written approval of CTTL.

The report must not be used by the client to claim product certification, approval, or endorsement by NVLAP, NIST, or any agency of the U.S. Government.

Test Laboratory:

CTTL-Telecommunication Technology Labs, CAICT

No. 52, Huayuan North Road, Haidian District, Beijing, P. R. China 100191.

Tel:+86(0)10-62304633-2512, Fax:+86(0)10-62304633-2504

Email: ctl_terminals@caict.ac.cn, website: www.caict.ac.cn



REPORT HISTORY

Report Number	Revision	Description	Issue Date
I19Z62252-IOT07	Rev.0	1st edition	2020-02-19

CONTENTS

CONTENTS	3
1. TEST LATORATORY	5
1.1. INTRODUCTION & ACCREDITATION	5
1.2. TESTING LOCATION	5
1.3. TESTING ENVIRONMENT.....	5
1.1. PROJECT DATE	5
1.2. SIGNATURE	5
2. CLIENT INFORMATION	6
2.1. APPLICANT INFORMATION	6
2.2. MANUFACTURER INFORMATION	6
3. EQUIPMENT UNDER TEST (EUT) AND ANCILLARY EQUIPMENT(AE)	7
3.1. ABOUT EUT	7
3.2. INTERNAL IDENTIFICATION OF EUT USED DURING THE TEST	7
3.3. INTERNAL IDENTIFICATION OF AE USED DURING THE TEST	7
3.4. GENERAL DESCRIPTION.....	7
3.5. EUT SET-UPS	7
4. REFERENCE DOCUMENTS	8
4.1. DOCUMENTS SUPPLIED BY APPLICANT.....	8
4.2. REFERENCE DOCUMENTS FOR TESTING	8
5. LABORATORY ENVIRONMENT	8
6. SUMMARY OF TEST RESULTS	9
6.1. SUMMARY OF TEST RESULTS	9
6.2. STATEMENTS.....	9
6.3. TEST CONDITIONS	9
7. TEST EQUIPMENTS UTILIZED	10
8. MEASUREMENT UNCERTAINTY	11
8.1. TRANSMITTER OUTPUT POWER	11
8.2. PEAK POWER SPECTRAL DENSITY	11
8.3. OCCUPIED 6DB BANDWIDTH	11
8.4. BAND EDGES COMPLIANCE	11
8.5. SPURIOUS EMISSIONS	11
8.6. AC POWER-LINE CONDUCTED EMISSION	11
ANNEX A: MEASUREMENT RESULTS	12
A.1. MEASUREMENT METHOD	12
A.2. MAXIMUM AVERAGE OUTPUT POWER-CONDUCTED	13

A.3. PEAK POWER SPECTRAL DENSITY	16
A.4. OCCUPIED 6DB BANDWIDTH	17
A.5. TRANSMITTER SPURIOUS EMISSION.....	25
A.5.1 TRANSMITTER SPURIOUS EMISSION - CONDUCTED	25
A.5.2 TRANSMITTER SPURIOUS EMISSION - RADIATED	56
A.6. BAND EDGES COMPLIANCE	64
A.6.1 BAND EDGES - CONDUCTED.....	64
A.6.2 BAND EDGES - RADIATED	71
FIG. 83 BAND EDGES (802.11A, 5745MHZ)	72
FIG. 84 BAND EDGES (802.11A, 5825MHZ)	72
FIG. 85 BAND EDGES (802.11N-HT20, 5745MHZ).....	73
FIG. 86 BAND EDGES (802.11N-HT20, 5825MHZ).....	73
FIG. 87 BAND EDGES (802.11AC-HT20, 5745MHZ).....	74
FIG. 88 BAND EDGES (802.11AC-HT20, 5825MHZ).....	74
FIG. 89 BAND EDGES (802.11N-HT40, 5755MHZ).....	75
FIG. 90 BAND EDGES (802.11N-HT40, 5795MHZ).....	75
FIG. 91 BAND EDGES (802.11AC-HT40, 5755MHZ).....	76
FIG. 92 BAND EDGES (802.11AC-HT40, 5795MHZ).....	76
FIG. 93 BAND EDGES (802.11AC-HT80, 5775MHZ).....	77
FIG. 94 BAND EDGES (802.11AC-HT80, 5775MHZ).....	77
A.7. AC POWERLINE CONDUCTED EMISSION	78
FIG. 95	78
FIG. 96	78
FIG. 95 AC POWERLINE CONDUCTED EMISSION-802.11A	79
FIG. 96 AC POWERLINE CONDUCTED EMISSION-IDLE.....	80
ANNEX B: ACCREDITATION CERTIFICATE.....	81

1. TEST LABORATORY

1.1. Introduction & Accreditation

Telecommunication Technology Labs, CAICT is an ISO/IEC 17025:2005 accredited test laboratory under NATIONAL VOLUNTARY LABORATORY ACCREDITATION PROGRAM (NVLAP) with lab code 600118-0, and is also an FCC accredited test laboratory (CN5017), and ISED accredited test laboratory (CN0066). The detail accreditation scope can be found on NVLAP website.

1.2. Testing Location

Conducted testing Location: CTTL(huayuan North Road)

Address: No. 52, Huayuan North Road, Haidian District, Beijing,
P. R. China100191

Radiated testing Location: CTTL(huayuan North Road)

Address: No. 52, Huayuan North Road, Haidian District, Beijing,
P. R. China100191

Radiated testing Location: CTTL(BDA)

Address: No.18A, Kangding Street, Beijing Economic-Technology
Development Area, Beijing, P. R. China 100176

1.3. Testing Environment

Normal Temperature: 15-35°C

Relative Humidity: 20-75%

1.1. Project date

Testing Start Date: 2019-12-23

Testing End Date: 2020-02-01

1.2. Signature



Xie Fangfang

(Prepared this test report)

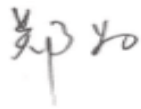

Zheng Wei

(Reviewed this test report)

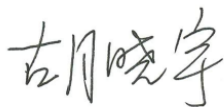

Hu Xiaoyu

(Approved this test report)



2. CLIENT INFORMATION

2.1. Applicant Information

Company Name: TCL Communication Ltd.
Address: 5/F, Building 22E, 22 Science Park East Avenue, Hong Kong Science
Park, Shatin, NT, Hong Kong
City: Hong Kong
Postal Code: /
Country: China
Telephone: 0086-755-36611722
Fax: 0086-755-36612000-81722

2.2. Manufacturer Information

Company Name: TCL Communication Ltd.
Address: 5/F, Building 22E, 22 Science Park East Avenue, Hong Kong Science
Park, Shatin, NT, Hong Kong
City: Hong Kong
Postal Code: /
Country: China
Telephone: 0086-755-36611722
Fax: 0086-755-36612000-81722

3. EQUIPMENT UNDER TEST (EUT) AND ANCILLARY

EQUIPMENT(AE)

3.1. About EUT

Description	LTE Mobile WiFi Router
Model name	MW43TM
FCC ID	2ACCJB117
WLAN Frequency Range	ISM Band: 5725MHz~5850MHz
Type of modulation	OFDM
Voltage	3.8V

3.2. Internal Identification of EUT used during the test

EUT ID*	SN or IMEI	HW Version	SW Version
EUT1	015659000001186	03	MW43_ZZ_02.00_01
EUT2	015659000001939	03	MW43_ZZ_02.00_01

*EUT ID: is used to identify the test sample in the lab internally.

3.3. Internal Identification of AE used during the test

AE ID*	Description	SN
AE1	Battery	/
AE3	Charger	CH001/004
AE5	USB Cable	DC012/022

AE1

Model	TLi043F1/CAB4300004C1
Manufacturer	BYD
Capacitance	4400mAh
Nominal voltage	3.7 V

AE3

Model	UC13US
Manufacturer	Puan
Length of cable	/

AE5

Model	CDA0000123C2
Manufacturer	SHENGHUA
Length of cable	/

*AE ID: is used to identify the test sample in the lab internally.

3.4. General Description

Equipment Under Test (EUT) is a model of LTE Mobile WiFi Router with integrated antenna. It consists of normal options: Battery and Charger.

Manual and specifications of the EUT were provided to fulfil the test.

Samples undergoing test were selected by the Client.

3.5. EUT set-ups

EUT set-up No.	Combination of EUT and AE	Remarks
Set.12	EUT1+ AE1+ AE3+ AE5	WIFI

4. REFERENCE DOCUMENTS

4.1. Documents supplied by applicant

EUT feature information is supplied by the applicant or manufacturer, which is the basis of testing.

4.2. Reference Documents for testing

The following documents listed in this section are referred for testing.

FCC Part15	FCC CFR 47, Part 15, Subpart C and E: 15.205 Restricted bands of operation; 15.209 Radiated emission limits, general requirements; 15.407 General technical requirements	2018
ANSI C63.10	Methods of Measurement of Radio-Noise Emissions from Low-Voltage Electrical and Electronic Equipment in the Range of 9 kHz to 40 GHz	2013
UNII: KDB 789033 D02	General U-NII Test Procedures New Rules v02r01	2017-12
KDB 558074 D01	Federal Communications Commission Office of Engineering and Technology Laboratory Division GUIDANCE FOR COMPLIANCE MEASUREMENTS ON DIGITAL TRANSMISSION SYSTEM, FREQUENCY HOPPING SPREAD SPECTRUM SYSTEM, AND HYBRID SYSTEM DEVICES OPERATING UNDER SECTION 15.247 OF THE FCC RULES	2019

5. LABORATORY ENVIRONMENT

Conducted RF performance testing is performed in shielding room.

EMC performance testing is performed in Semi-anechoic chamber.

6. SUMMARY OF TEST RESULTS

6.1. Summary of Test Results

SUMMARY OF MEASUREMENT RESULTS	Sub-clause of Part15C	Sub-clause of IC	Verdict
Maximum Peak Output Power	15.407 (a)	/	P
Peak Power Spectral Density	15.407 (a)	/	P
Occupied 6dB Bandwidth	15.407 (e)	/	P
Band Edges Compliance - Conducted& Radiated	15.407 (b)	/	P
Transmitter Spurious Emission - Conducted	15.407	/	P
Transmitter Spurious Emission - Radiated	15.407, 15.205, 15.209	/	P
AC Powerline Conducted Emission	15.107, 15.207	/	P

Please refer to **ANNEX A** for detail.

Terms used in Verdict column

P	Pass, The EUT complies with the essential requirements in the standard.
NM	Not measured, The test was not measured by CTTL
NA	Not Applicable, The test was not applicable
F	Fail, The EUT does not comply with the essential requirements in the standard

6.2. Statements

CTTL has evaluated the test cases requested by the client/matrix manufacturer as listed in section 6.1 of this report for the EUT specified in section 3 according to the standards or reference documents listed in section 4.1.

This report only deals with the WLAN function among the features described in section 3.

6.3. Test Conditions

For this report, all the test cases are tested under normal temperature and normal voltage, and also under norm humidity, the specific condition is shown as follows:

Temperature	26°C
Voltage	3.8V
Humidity	44%

7. TEST EQUIPMENTS UTILIZED

Conducted test system

No.	Equipment	Model	Serial Number	Manufacturer	Calibration Period	Calibration Due date
1	Vector Signal Analyzer	FSQ40	200089	Rohde & Schwarz	1 year	2020-05-15
2	LISN	ENV216	101200	Rohde & Schwarz	1 year	2020-03-14
3	Test Receiver	ESCI	100344	Rohde & Schwarz	1 year	2020-02-14
4	Shielding Room	S81	/	ETS-Lindgren	/	/

Radiated emission test system

No.	Equipment	Model	Serial Number	Manufacturer	Calibration Period	Calibration Due date
1	Test Receiver	ESU26	100376	Rohde & Schwarz	1 year	2020-10-30
2	BiLog Antenna	VULB9163	9163-514	Schwarzbeck	1 year	2020-02-03
3	Universal Radio Communication Tester	CMW500	159408	R&S	1 year	2020-02-03
4	EMI Antenna	3117	00139065	ETS-Lindgren	1 year	2020-11-10
5	EMI Antenna	3116	2663	ETS-Lindgren	1 year	2020-05-31
6	Test Receiver	FSV40	101047	R&S	1 year	2020-05-16

8. Measurement Uncertainty

8.1. Transmitter Output Power

Measurement Uncertainty: 0.387dB,k=1.96

8.2. Peak Power Spectral Density

Measurement Uncertainty: 0.705dB,k=1.96

8.3. Occupied 6dB Bandwidth

Measurement Uncertainty: 60.80Hz,k=1.96

8.4. Band Edges Compliance

Measurement Uncertainty : 0.62dB,k=1.96

8.5. Spurious Emissions

Conducted (k=1.96)

Frequency Range	Uncertainty(dB)
$30\text{MHz} \leq f \leq 2\text{GHz}$	1.22
$2\text{GHz} \leq f \leq 3.6\text{GHz}$	1.22
$3.6\text{GHz} \leq f \leq 8\text{GHz}$	1.22
$8\text{GHz} \leq f \leq 12.75\text{GHz}$	1.51
$12.75\text{GHz} \leq f \leq 26\text{GHz}$	1.51
$26\text{GHz} \leq f \leq 40\text{GHz}$	1.59

Radiated (k=2)

Frequency Range	Uncertainty(dB)
9kHz-30MHz	/
$30\text{MHz} \leq f \leq 1\text{GHz}$	5.40
$1\text{GHz} \leq f \leq 18\text{GHz}$	4.32
$18\text{GHz} \leq f \leq 40\text{GHz}$	5.26

8.6. AC Power-line Conducted Emission

Measurement Uncertainty : 3.08dB,k=2

ANNEX A: MEASUREMENT RESULTS

A.1. Measurement Method

A.1.1. Conducted Measurements

- 1). Connect the EUT to the test system correctly.
- 2). Set the EUT to the required work mode.
- 3). Set the EUT to the required channel.
- 4). Set the spectrum analyzer to start measurement.
- 5). Record the values. Vector Signal Analyzer

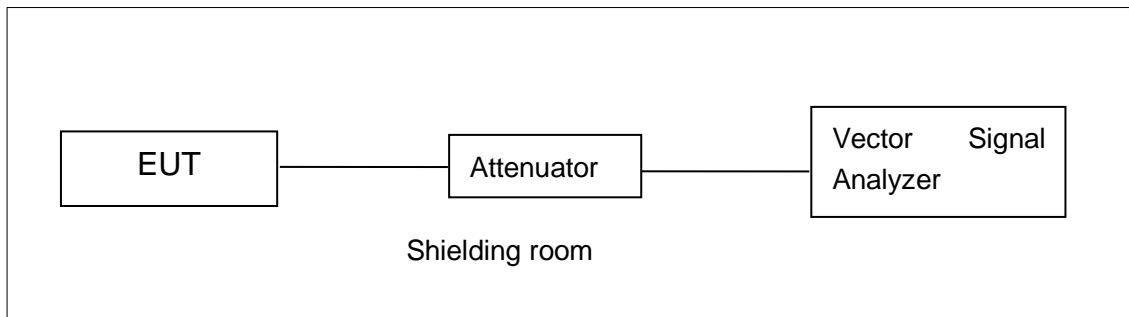

A.1.2. Radiated Emission Measurements

In the case of radiated emission, the used settings are as follows,

Sweep frequency from 30 MHz to 1GHz, RBW = 100 kHz, VBW = 300 kHz;

Sweep frequency from 1 GHz to 26GHz, RBW = 1MHz, VBW = 10Hz;

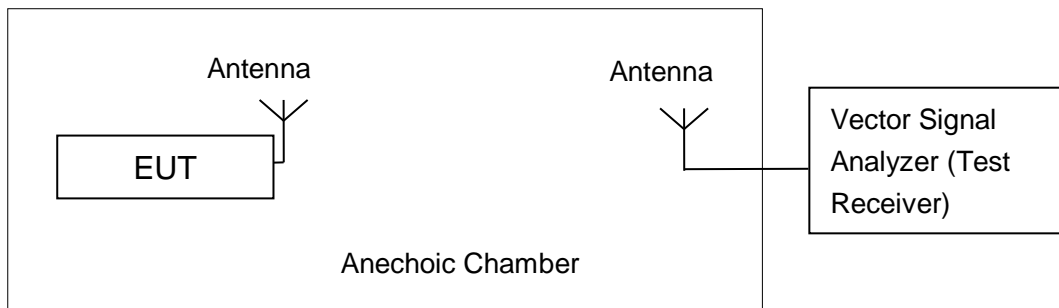

The measurement is made according to ANSI C63.10.

The radiated emission test is performed in semi-anechoic chamber. The distance from the EUT to the reference point of measurement antenna is 3m. The test is carried out on both vertical and horizontal polarization and only maximization result of both polarizations is kept. During the test, the turntable is rotated 360° and the measurement antenna is moved from 1m to 4m to get the maximization result.

A.2. Maximum Average Output Power-Conducted

Method of Measurement: See ANSI C63.10-clause 12.3.2.2 Method SA-1

Measurement Limit and Method:

Standard	Limit (dBm)
FCC CRF Part 15.407(a)	< 30

Measurement Results:

Measurement Results:

11a	6	9	12	18	24	36	48	54		
	99.11%	99.12%	98.13%	98.02%	97.05%	94.12%	93.33%	91.32%		
11n-20	MCS0	MCS1	MCS2	MCS3	MCS4	MCS5	MCS6	MCS7		
	98.81%	99.23%	98.21%	96.36%	95.23%	96.41%	97.47%	96.48%		
11n-40	MCS0	MCS1	MCS2	MCS3	MCS4	MCS5	MCS6	MCS7		
	97.80%	97.56%	97.32%	95.38%	97.23%	96.00%	95.00%	93.73%		
11ac-20	MCS0	MCS1	MCS2	MCS3	MCS4	MCS5	MCS6	MCS7	MCS8	
	98.93%	99.25%	98.18%	98.00%	97.21%	95.20%	94.00%	94.00%	93.86%	
11ac-40	MCS0	MCS1	MCS2	MCS3	MCS4	MCS5	MCS6	MCS7	MCS8	MCS9
	98.16%	98.05%	97.00%	97.00%	96.08%	96.00%	95.21%	95.00%	94.00%	93.50%
11ac-80	MCS0	MCS1	MCS2	MCS3	MCS4	MCS5	MCS6	MCS7	MCS8	MCS9
	95.25%	95.00%	95.22%	94.37%	95.00%	93.36%	94.33%	95.00%	93.22%	92.98%

802.11a mode

Mode	Data Rate (Mbps)	Test Result (dBm)		
		5745MHz (Ch149)	5785MHz (Ch157)	5825MHz (Ch165)
802.11a	6	16.06	/	/
	9	16.05	/	/
	12	16.11	/	/
	18	16.13	/	/
	24	16.30	16.14	16.25
	36	13.86	/	/
	48	12.92	/	/
	54	12.96	/	/

The data rate 24Mbps is selected as worse condition, and the following cases are performed with this condition.

802.11n-HT20 mode

Mode	Data Rate (Index)	Test Result (dBm)		
		5745MHz (Ch149)	5785MHz (Ch157)	5825MHz (Ch165)
802.11n (20MHz)	MCS0	16.30	15.85	14.46
	MCS1	15.91	/	/
	MCS2	15.90	/	/
	MCS3	13.66	/	/
	MCS4	13.27	/	/
	MCS5	11.92	/	/
	MCS6	11.83	/	/
	MCS7	11.66	/	/

The data rate MCS0 is selected as worse condition, and the following cases are performed with this condition.

802.11ac-HT20 mode

Mode	Data Rate (Index)	Test Result (dBm)		
		5745MHz (Ch149)	5785MHz (Ch157)	5825MHz (Ch165)
802.11ac (20MHz)	MCS0	15.11	15.46	15.61
	MCS1	14.93	/	/
	MCS2	15.02	/	/
	MCS3	13.82	/	/
	MCS4	13.80	/	/
	MCS5	13.79	/	/
	MCS6	14.16	/	/
	MCS7	14.21	/	/
	MCS8	11.26	/	/

The data rate MCS0 is selected as worse condition, and the following cases are performed with this condition.

802.11n-HT40 mode

Mode	Data Rate (Index)	Test Result (dBm)	
		5755MHz (Ch151)	5795MHz (Ch159)
802.11n (40MHz)	MCS0	15.00	14.74
	MCS1	14.82	/
	MCS2	14.82	/
	MCS3	12.88	/
	MCS4	12.62	/
	MCS5	11.93	/
	MCS6	12.05	/
	MCS7	12.06	/

The data rate MCS0 is selected as worse condition, and the following cases are performed with this condition.

802.11ac-HT40 mode

Mode	Data Rate (Index)	Test Result (dBm)	
		5755MHz (Ch151)	5795MHz (Ch159)
802.11ac (40MHz)	MCS0	15.00	14.76
	MCS1	14.93	/
	MCS2	14.90	/
	MCS3	12.88	/
	MCS4	12.66	/
	MCS5	11.88	/
	MCS6	11.92	/
	MCS7	12.01	/
	MCS8	10.13	/
	MCS9	9.98	/

The data rate MCS0 is selected as worse condition, and the following cases are performed with this condition.

802.11ac-HT80 mode

Mode	Data Rate (Index)	Test Result (dBm)
		5775MHz (Ch155)
802.11ac (80MHz)	MCS0	13.45
	MCS1	13.40
	MCS2	13.37
	MCS3	12.66
	MCS4	12.61
	MCS5	11.02
	MCS6	11.15
	MCS7	10.48
	MCS8	9.40
	MCS9	9.39

The data rate MCS0 is selected as worse condition, and the following cases are performed with this condition.

Conclusion: PASS

A.3. Peak Power Spectral Density

Measurement Limit:

Standard	Limit
FCC 47 CFR Part 15.407(a)	< 30 dBm/500 kHz

The measurement is made according to ANSI C63.10 and KDB789033 D02

Measurement Uncertainty:

Measurement Uncertainty	0.75dB
-------------------------	--------

Measurement Results:

Mode	Channel	Power Spectral Density (dBm/500kHz)	Conclusion
802.11a	149	5.18	P
	157	5.05	P
	165	5.05	P
802.11n HT20	149	5.38	P
	157	5.09	P
	165	4.84	P
802.11ac HT20	149	4.40	P
	157	3.97	P
	165	4.39	P
802.11n HT40	151	0.59	P
	159	0.28	P
802.11ac HT40	151	0.19	P
	159	0.10	P
802.11ac HT80	155	-3.52	P

Conclusion: PASS

A.4. Occupied 6dB Bandwidth

Measurement Limit:

Standard	Limit (kHz)
FCC 47 CFR Part 15.407 (e)	≥ 500

The measurement is made according to KDB789033 D02 .

Measurement Uncertainty:

Measurement Uncertainty	60.80Hz
-------------------------	---------

Measurement Result:

Mode	Channel	Occupied 6dB Bandwidth (MHz)		conclusion
		Fig.	Value	
802.11a	149	Fig.1	15.55	P
	157	Fig.2	16.45	P
	165	Fig.3	16.45	P
802.11n HT20	149	Fig.4	14.70	P
	157	Fig.5	15.65	P
	165	Fig.6	14.95	P
802.11ac HT20	149	Fig.7	15.05	P
	157	Fig.8	15.10	P
	165	Fig.9	15.60	P
802.11n HT40	151	Fig.10	34.56	P
	159	Fig.11	33.20	P
802.11ac HT40	151	Fig.12	33.76	P
	159	Fig.13	35.12	P
802.11ac HT80	155	Fig.14	75.20	P

Conclusion: PASS

Test graphs as below:

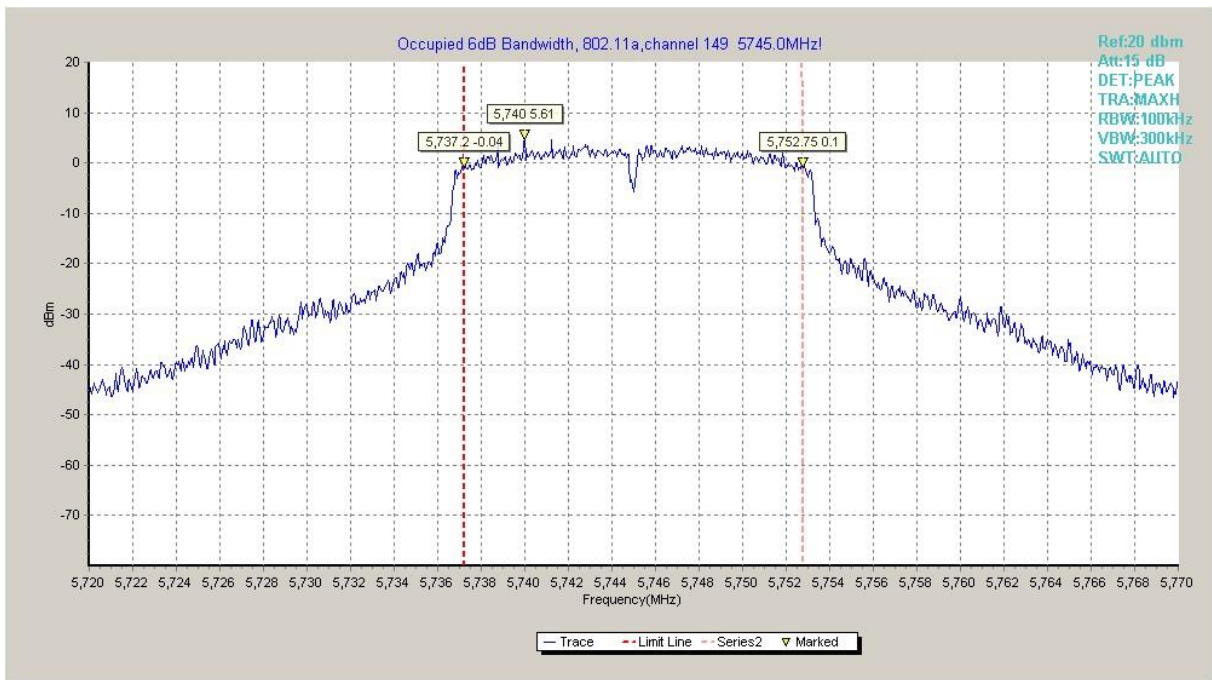

Fig. 1 Occupied 6dB Bandwidth (802.11a, Ch 149)

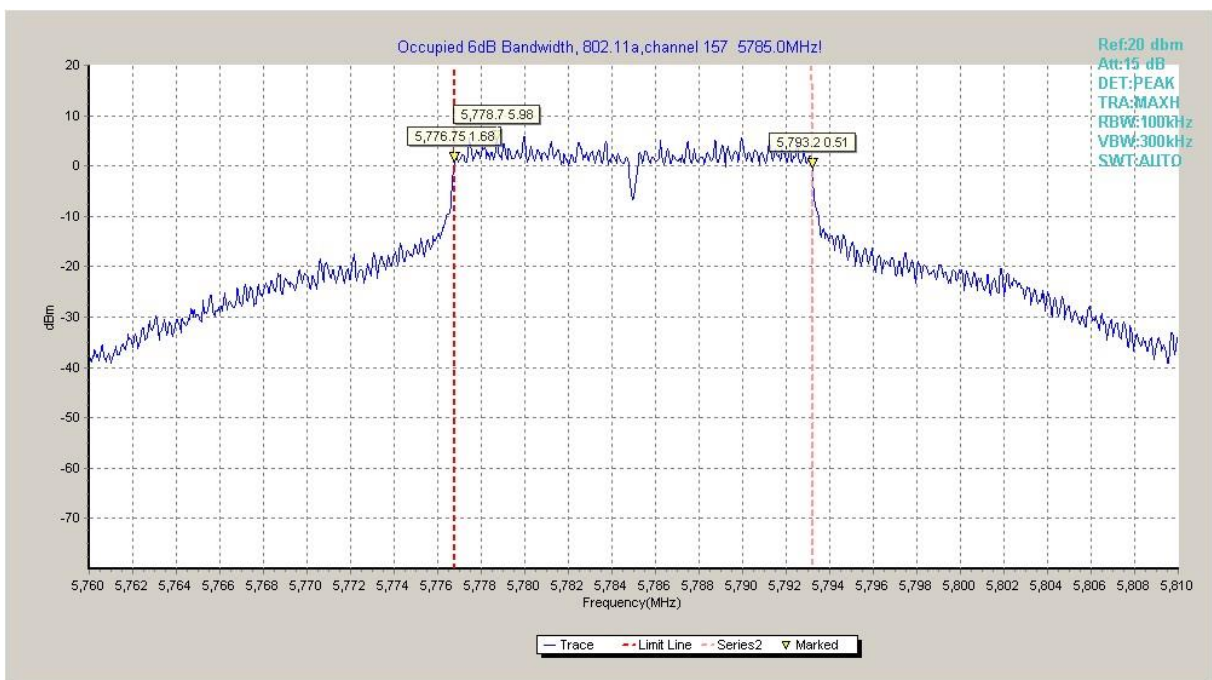

Fig. 2 Occupied 6dB Bandwidth (802.11a, Ch 157)

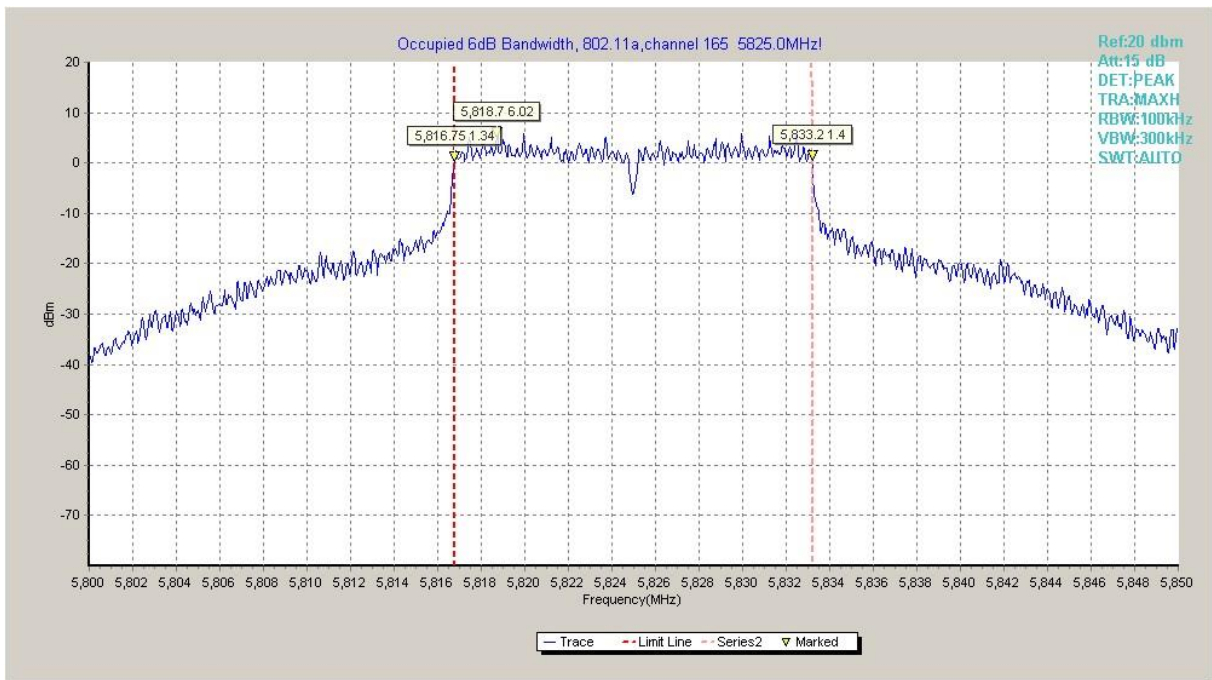

Fig. 3 Occupied 6dB Bandwidth (802.11a, Ch 165)

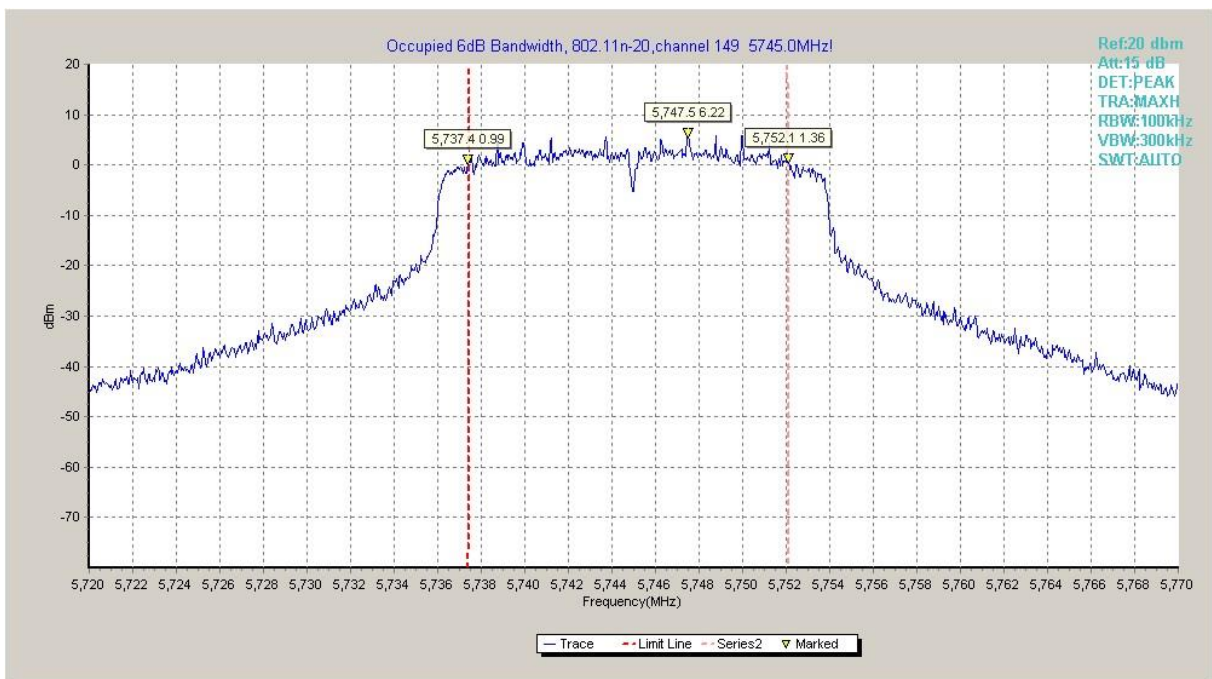

Fig. 4 Occupied 6dB Bandwidth (802.11n-HT20, Ch 149)

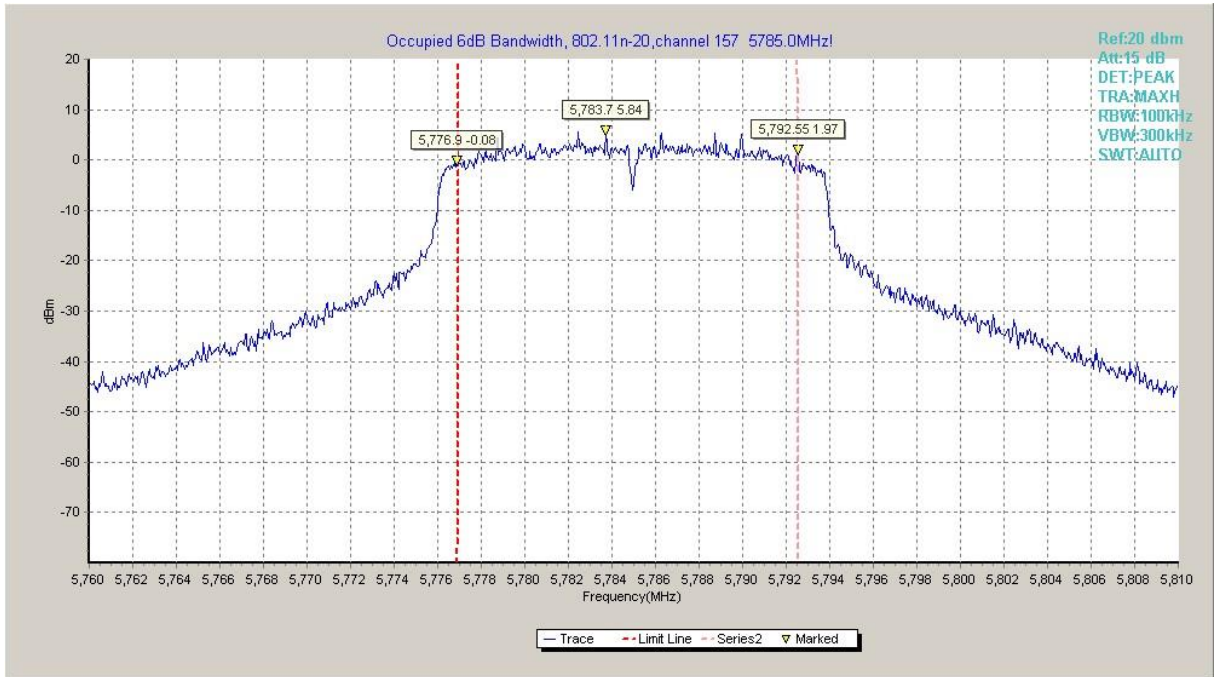

Fig. 5 Occupied 6dB Bandwidth (802.11n-HT20, Ch 157)

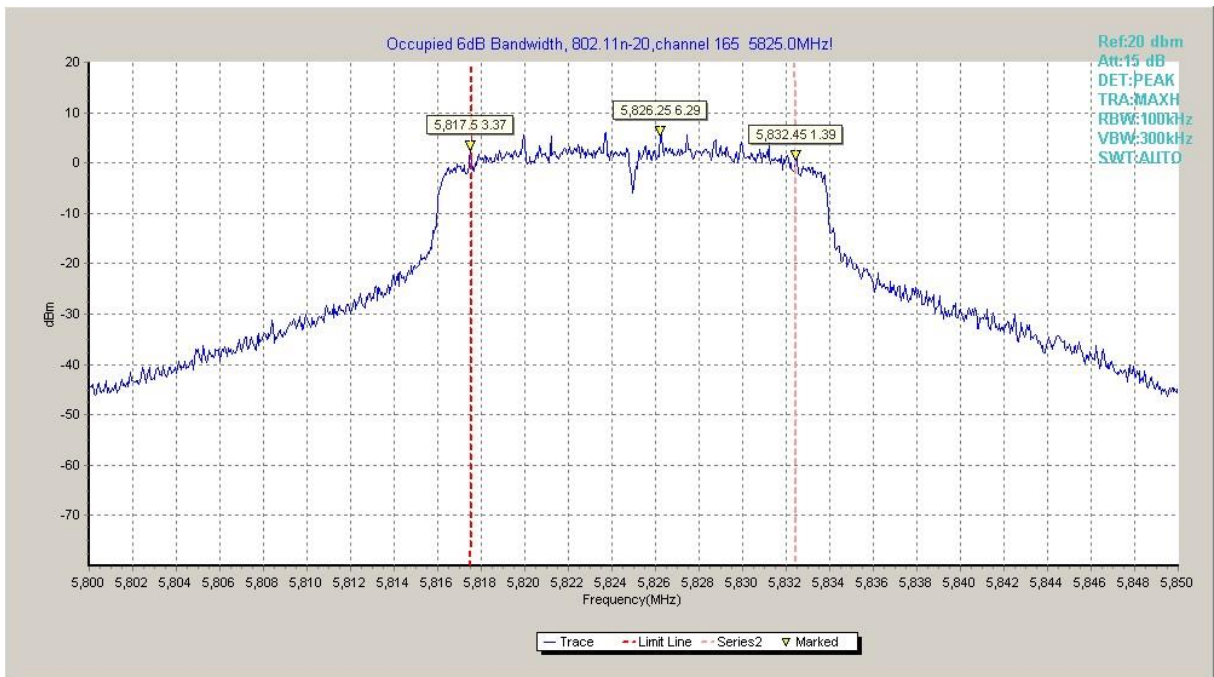

Fig. 6 Occupied 6dB Bandwidth (802.11n-HT20, Ch 165)

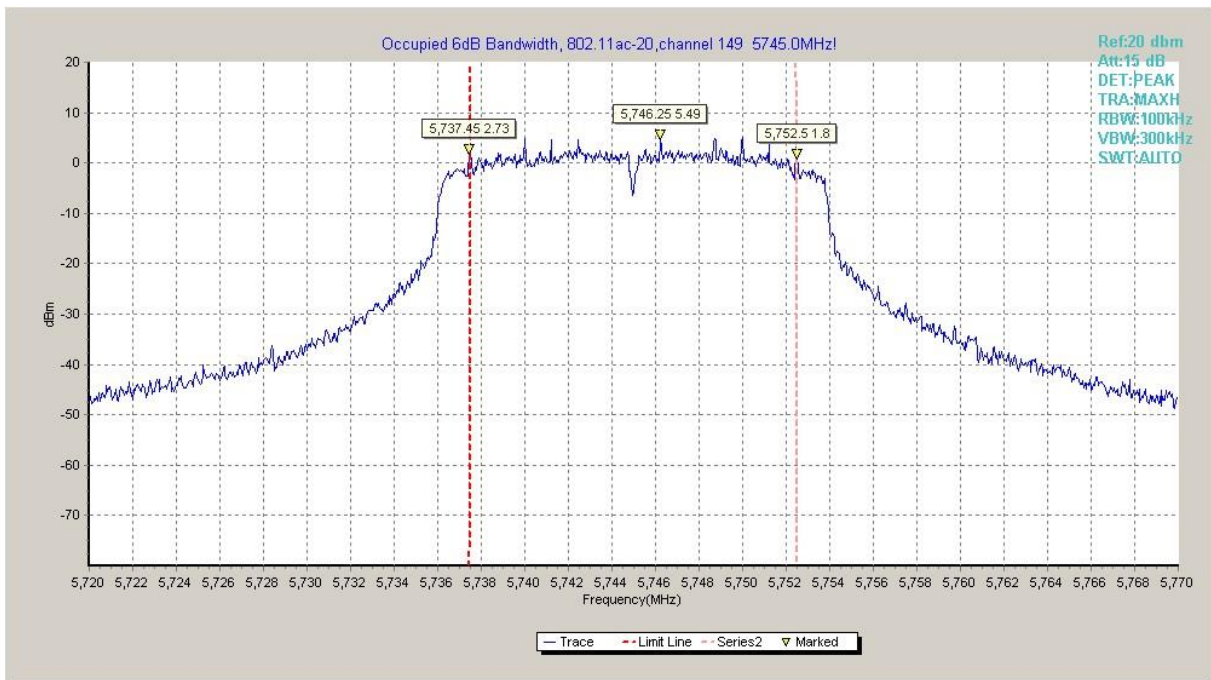

Fig. 7 Occupied 6dB Bandwidth (802.11ac-HT20, Ch 149)

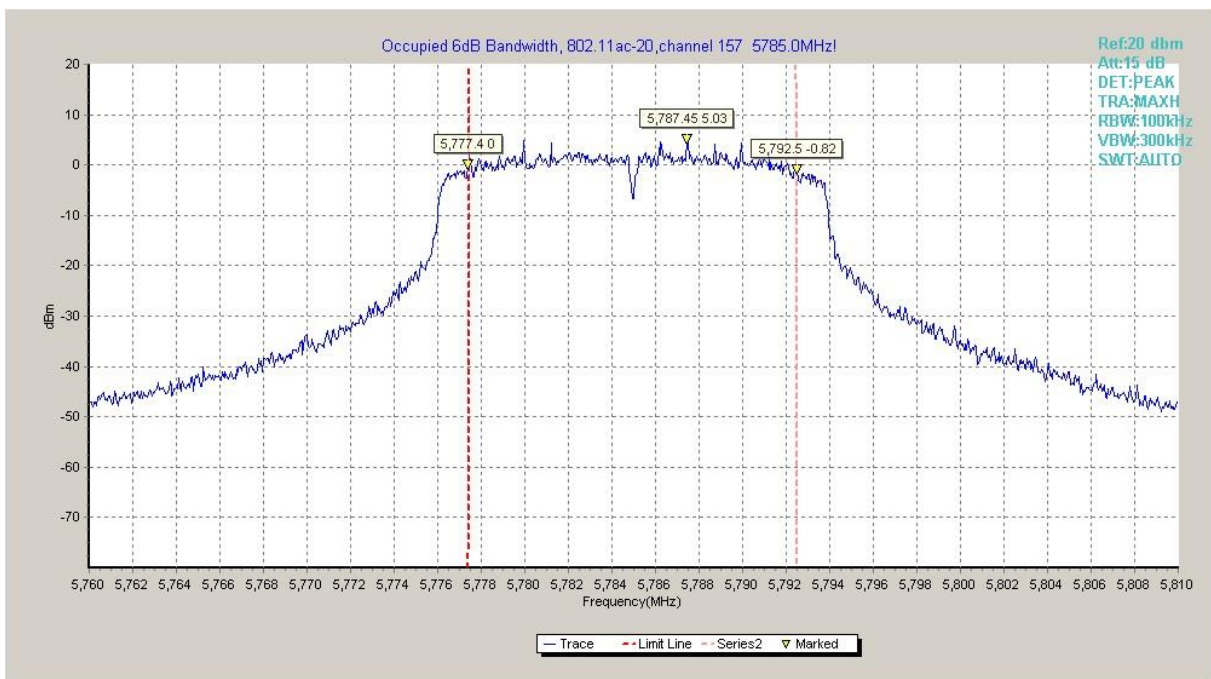

Fig. 8 Occupied 6dB Bandwidth (802.11ac-HT20, Ch 157)

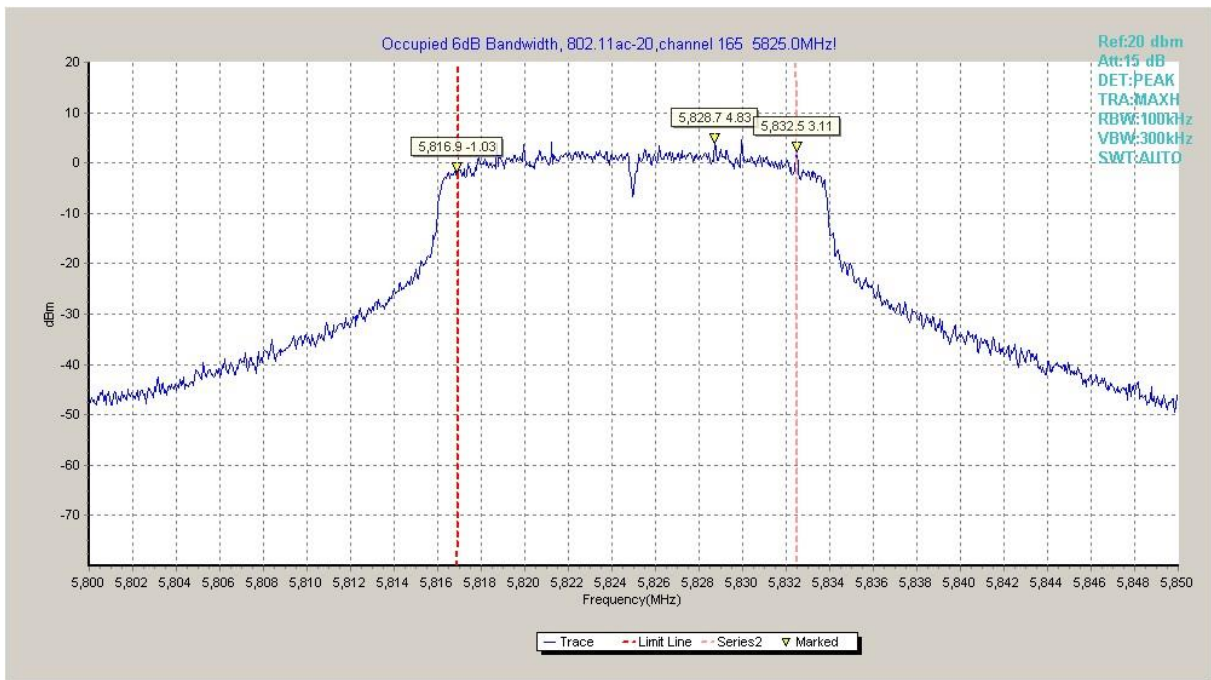

Fig. 9 Occupied 6dB Bandwidth (802.11ac-HT20, Ch 165)

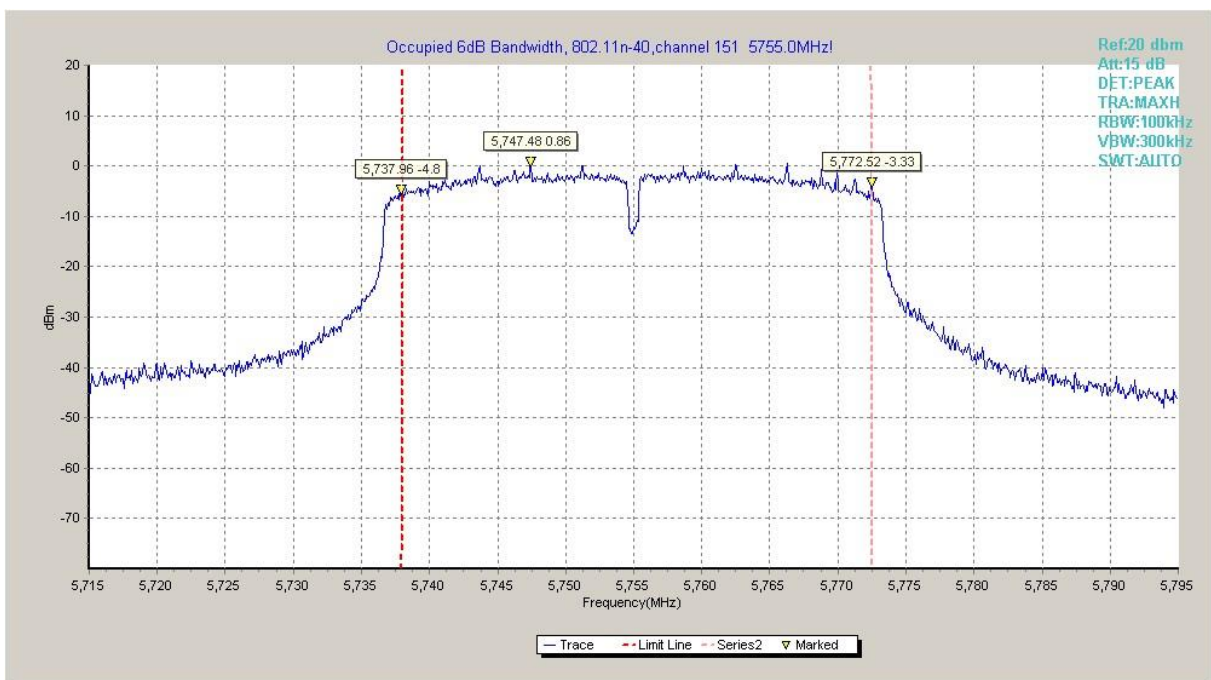

Fig. 10 Occupied 6dB Bandwidth (802.11n-HT40, Ch 151)

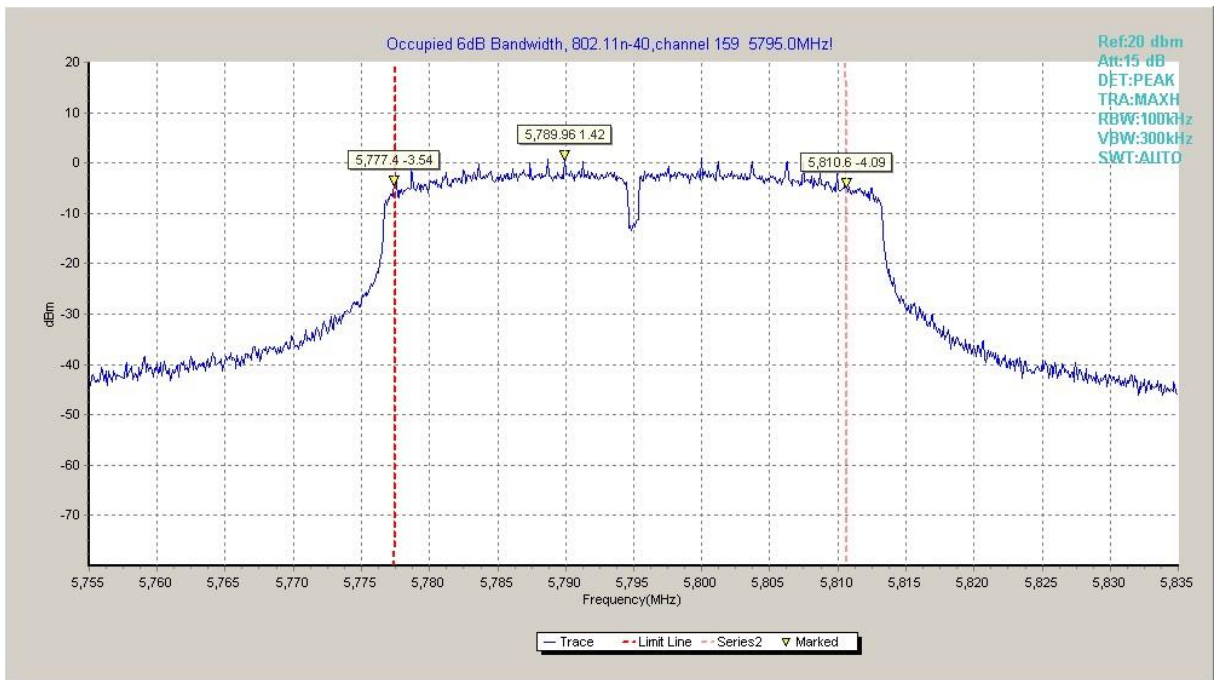

Fig. 11 Occupied 6dB Bandwidth (802.11n-HT40, Ch 159)

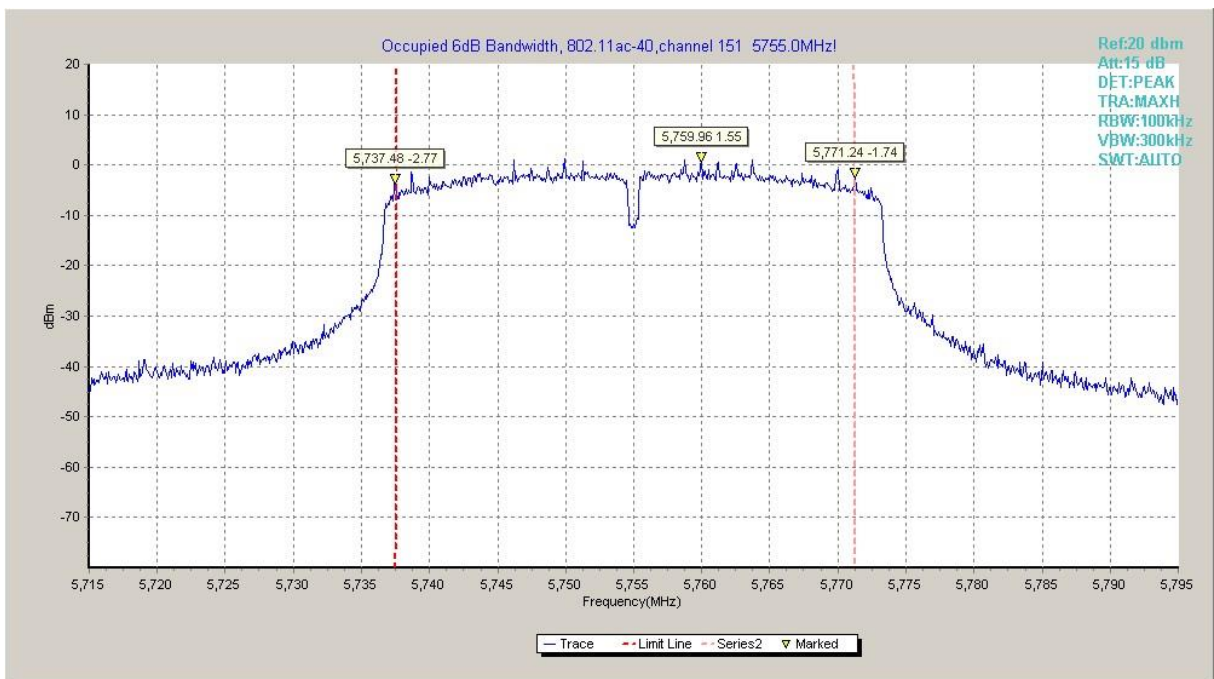

Fig. 12 Occupied 6dB Bandwidth (802.11ac-HT40, Ch 151)

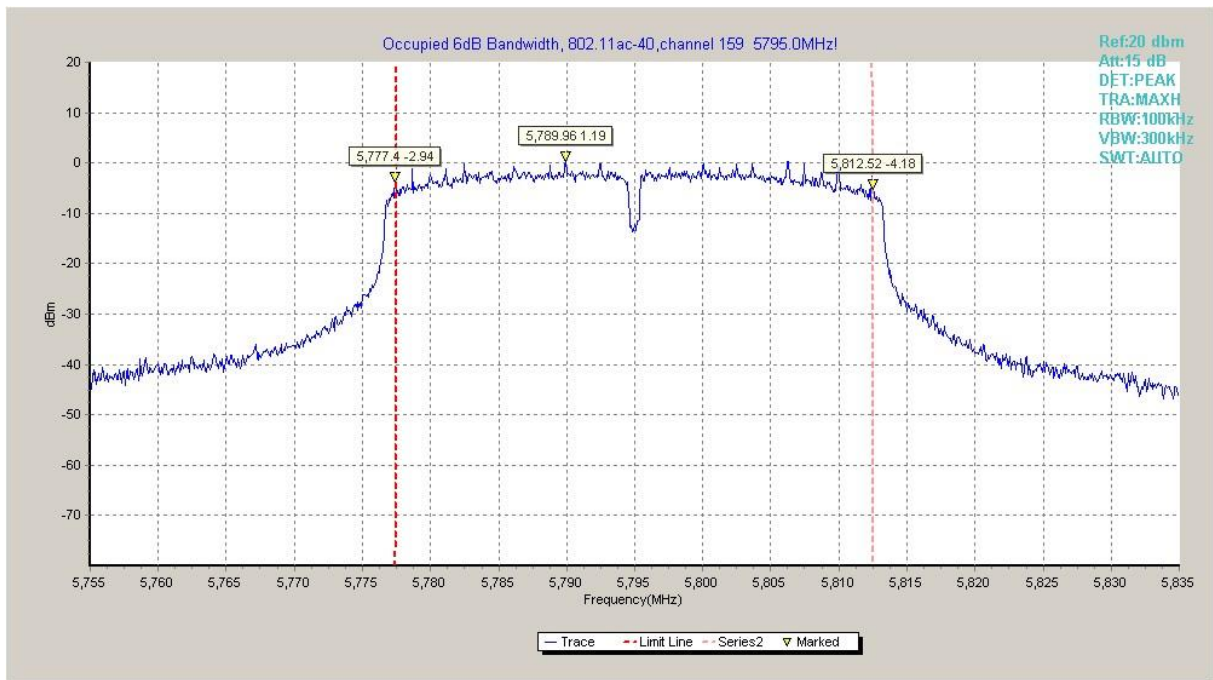

Fig. 13 Occupied 6dB Bandwidth (802.11ac-HT40, Ch 159)

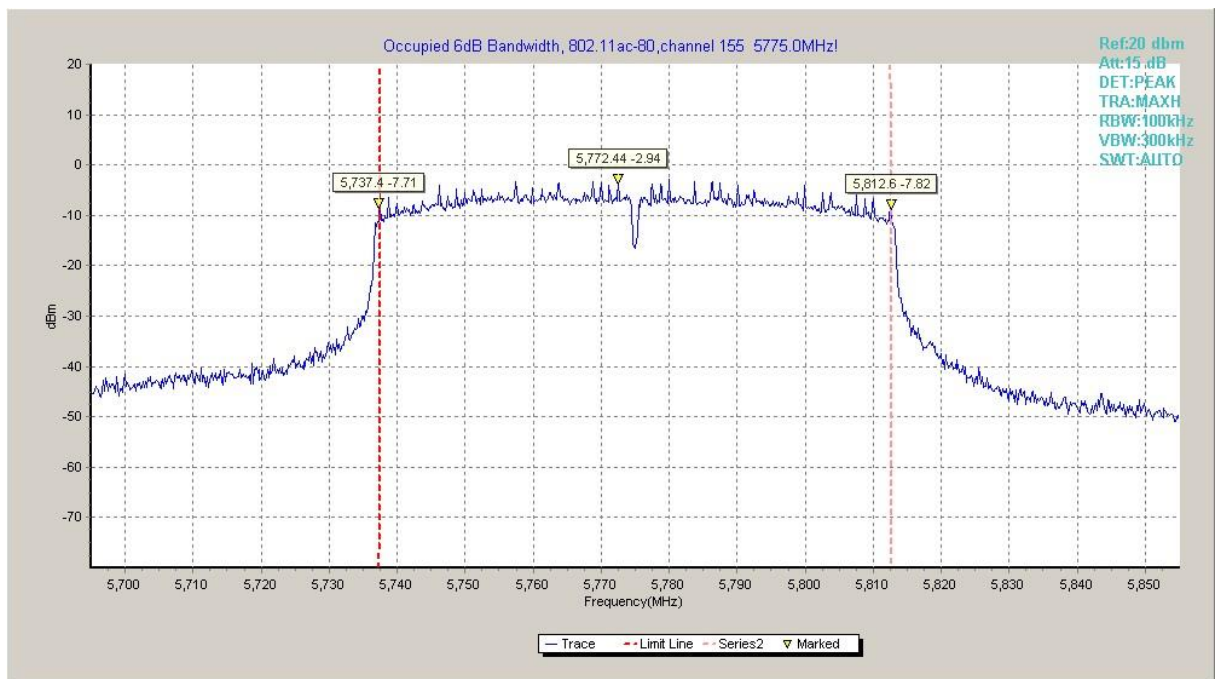

Fig. 14 Occupied 6dB Bandwidth (802.11ac-HT80, Ch 155)

A.5. Transmitter Spurious Emission

Measurement Limit:

Standard	Frequency (MHz)	Limit (dBm/MHz)
FCC 47 CFR Part 15.407	5725MHz~5850MHz	< -27

The measurement is made according to ANSI C63.10 .

In addition, radiated emissions which fall in the restricted bands, as defined in § 15.205(a), must also comply with the radiated emission limits specified in § 15.209(a) (see § 15.205(c)).

Frequency of emission (MHz)	Field strength(uV/m)	Field strength(dBuV/m)
30-88	100	40
88-216	150	43.5
216-960	200	46
Above 960	500	54

Measurement Uncertainty:

Frequency Range	Uncertainty(dB)
30MHz ≤ f ≤ 2GHz	0.63
2GHz ≤ f ≤ 3.6GHz	0.82
3.6GHz ≤ f ≤ 8GHz	1.55
8GHz ≤ f ≤ 20GHz	1.86
20GHz ≤ f ≤ 22GHz	1.90
22GHz ≤ f ≤ 26GHz	2.20

A.5.1 Transmitter Spurious Emission - Conducted

Measurement Results:

802.11a mode

MODE	Channel	Frequency Range	Test Results	Conclusion
802.11a	149	30 MHz ~ 1 GHz	Fig.15	P
		1 GHz ~ 12 GHz	Fig.16	P
		12 GHz ~ 25 GHz	Fig.17	P
		25 GHz ~ 40 GHz	Fig.18	P
	157	30 MHz ~ 1 GHz	Fig.19	P
		1 GHz ~ 12 GHz	Fig.20	P
		12 GHz ~ 25 GHz	Fig.21	P
		25 GHz ~ 40 GHz	Fig.22	P
	165	30 MHz ~ 1 GHz	Fig.23	P
		1 GHz ~ 12 GHz	Fig.24	P
		12 GHz ~ 25 GHz	Fig.25	P
		25 GHz ~ 40 GHz	Fig.26	P

802.11n-HT20 mode

MODE	Channel	Frequency Range	Test Results	Conclusion
802.11n HT20	149	30 MHz ~ 1 GHz	Fig.27	P
		1 GHz ~ 12 GHz	Fig.28	P
		12 GHz ~ 25 GHz	Fig.29	P
		25 GHz ~ 40 GHz	Fig.30	P
	157	30 MHz ~ 1 GHz	Fig.31	P
		1 GHz ~ 12 GHz	Fig.32	P
		12 GHz ~ 25 GHz	Fig.33	P
		25 GHz ~ 40 GHz	Fig.34	P
	165	30 MHz ~ 1 GHz	Fig.35	P
		1 GHz ~ 12 GHz	Fig.36	P
		12 GHz ~ 25 GHz	Fig.37	P
		25 GHz ~ 40 GHz	Fig.38	P

802.11ac-HT20 mode

MODE	Channel	Frequency Range	Test Results	Conclusion
802.11ac HT20	149	30 MHz ~ 1 GHz	Fig.39	P
		1 GHz ~ 12 GHz	Fig.40	P
		12 GHz ~ 25 GHz	Fig.41	P
		25 GHz ~ 40 GHz	Fig.42	P
	157	30 MHz ~ 1 GHz	Fig.43	P
		1 GHz ~ 12 GHz	Fig.44	P
		12 GHz ~ 25 GHz	Fig.45	P
		25 GHz ~ 40 GHz	Fig.46	P
	165	30 MHz ~ 1 GHz	Fig.47	P
		1 GHz ~ 12 GHz	Fig.48	P
		12 GHz ~ 25 GHz	Fig.49	P
		25 GHz ~ 40 GHz	Fig.50	P

802.11n-HT40 mode

MODE	Channel	Frequency Range	Test Results	Conclusion
802.11n HT40	151	30 MHz ~ 1 GHz	Fig.51	P
		1 GHz ~ 12 GHz	Fig.52	P
		12 GHz ~ 25 GHz	Fig.53	P
		25 GHz ~ 40 GHz	Fig.54	P
	159	30 MHz ~ 1 GHz	Fig.55	P
		1 GHz ~ 12 GHz	Fig.56	P
		12 GHz ~ 25 GHz	Fig.57	P
		25 GHz ~ 40 GHz	Fig.58	P

802.11ac-HT40 mode

MODE	Channel	Frequency Range	Test Results	Conclusion
802.11ac HT40	151	30 MHz ~ 1 GHz	Fig.59	P
		1 GHz ~ 12 GHz	Fig.60	P
		12 GHz ~ 25 GHz	Fig.61	P
		25 GHz ~ 40 GHz	Fig.62	P
	159	30 MHz ~ 1 GHz	Fig.63	P
		1 GHz ~ 12 GHz	Fig.64	P
		12 GHz ~ 25 GHz	Fig.65	P
		25 GHz ~ 40 GHz	Fig.66	P

802.11ac-HT80 mode

MODE	Channel	Frequency Range	Test Results	Conclusion
802.11ac HT80	155	30 MHz ~ 1 GHz	Fig.67	P
		1 GHz ~ 12 GHz	Fig.68	P
		12 GHz ~ 25 GHz	Fig.69	P
		25 GHz ~ 40 GHz	Fig.70	P

Conclusion: PASS

Test graphs as below:

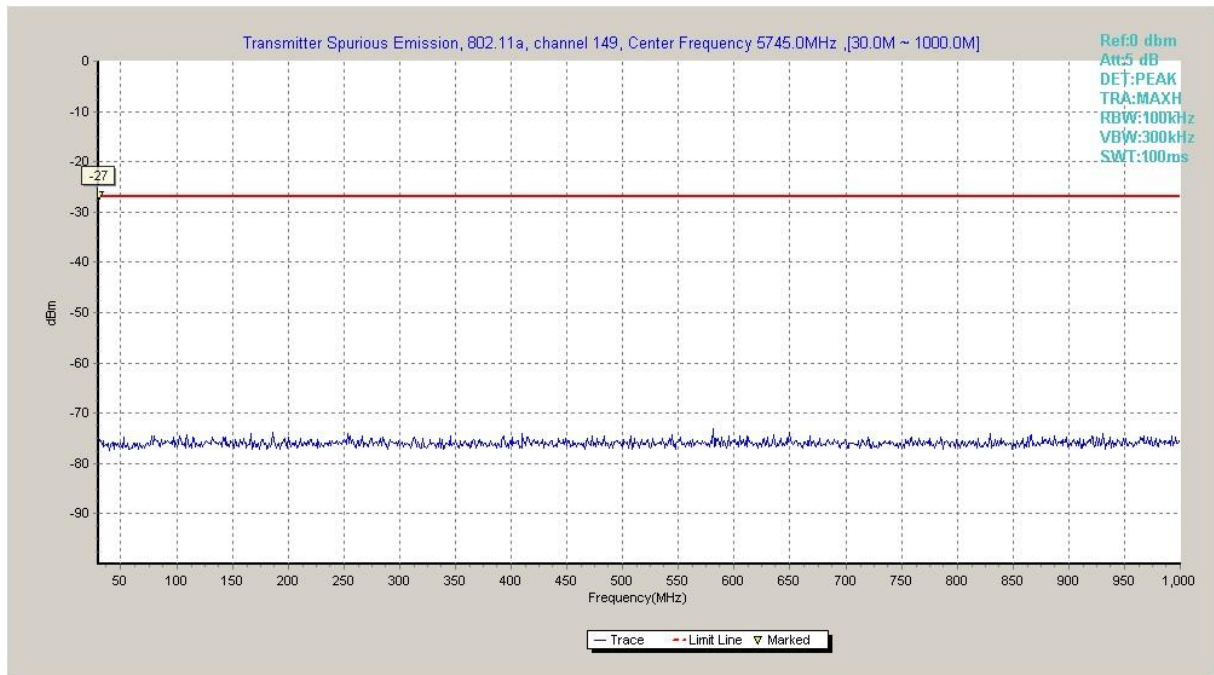

Fig. 15 Conducted Spurious Emission (802.11a, Ch149, 30 MHz-1 GHz)

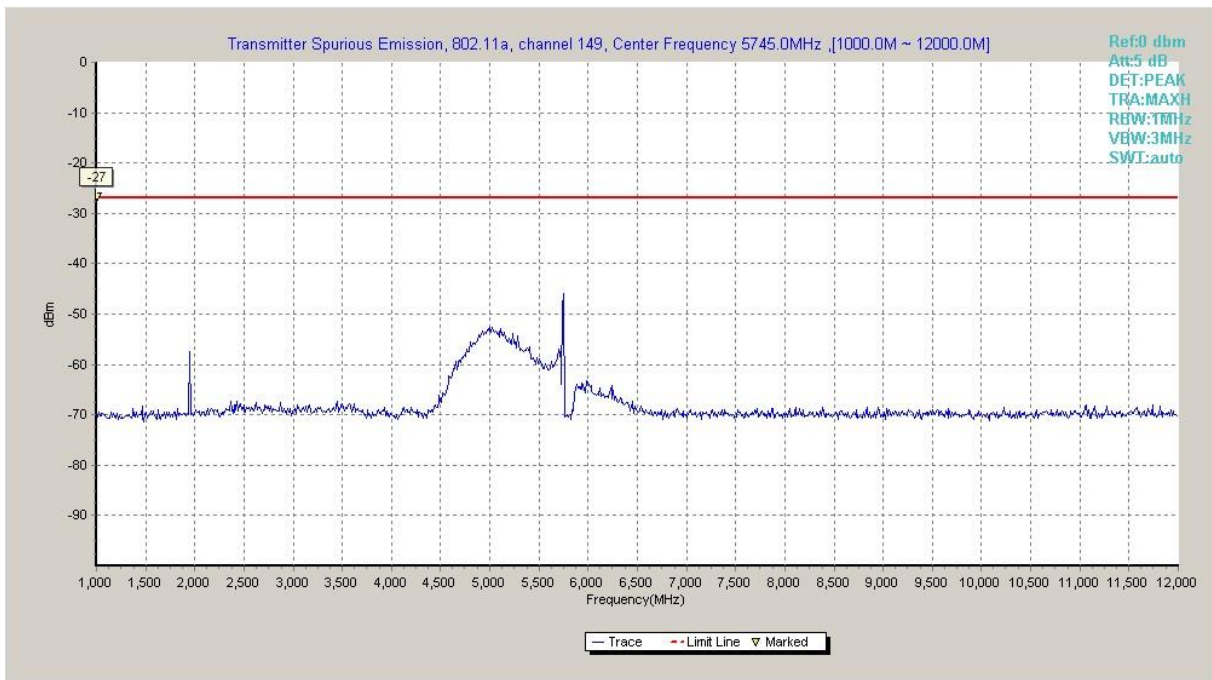

Fig. 16 Conducted Spurious Emission (802.11a, Ch149, 1 GHz -12 GHz)

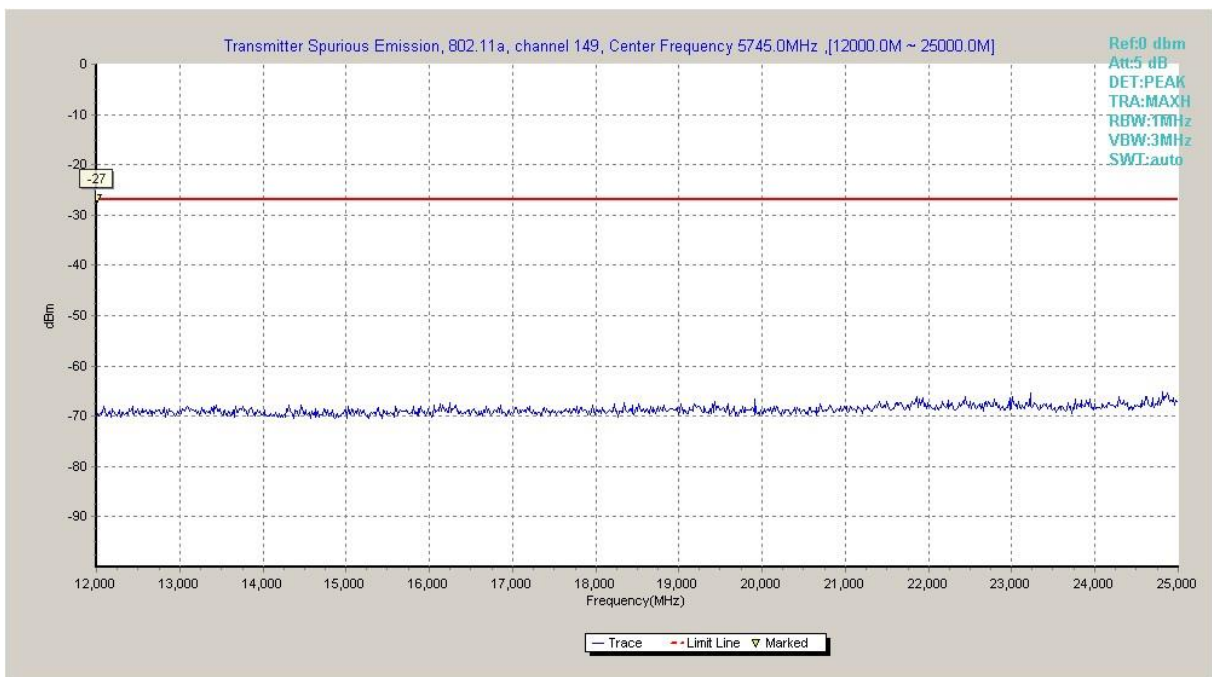

Fig. 17 Conducted Spurious Emission (802.11a, Ch149, 12 GHz-25 GHz)

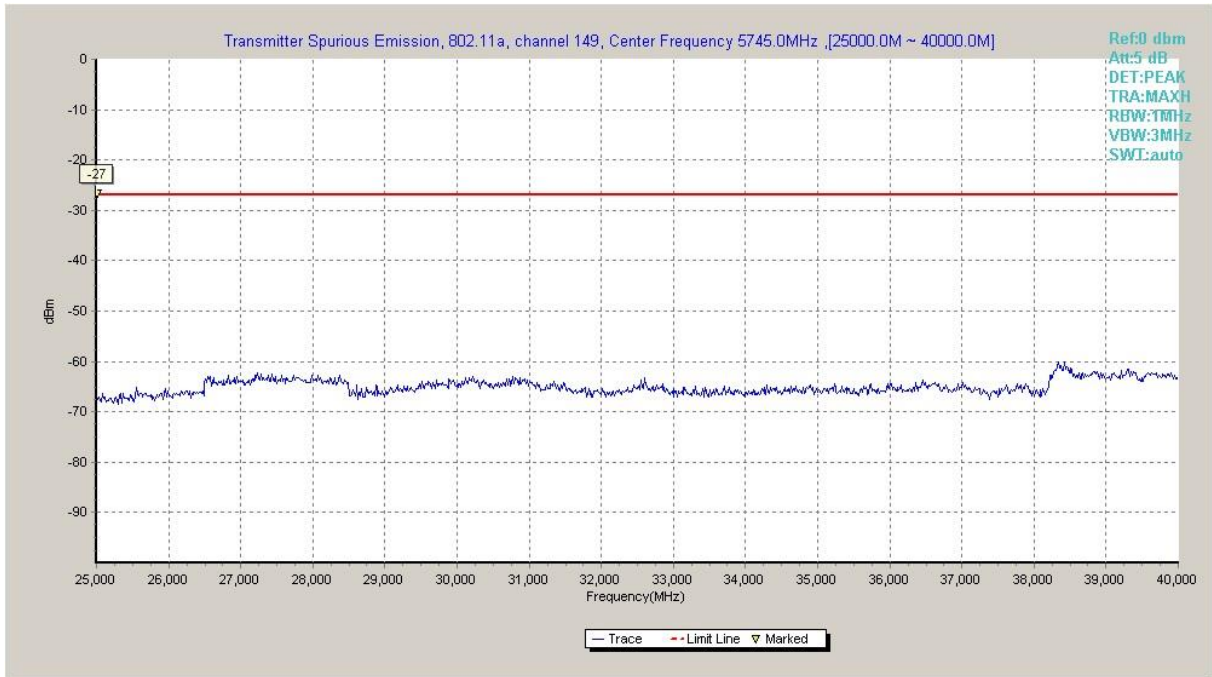

Fig. 18 Conducted Spurious Emission (802.11a, Ch149, 25 GHz-40 GHz)

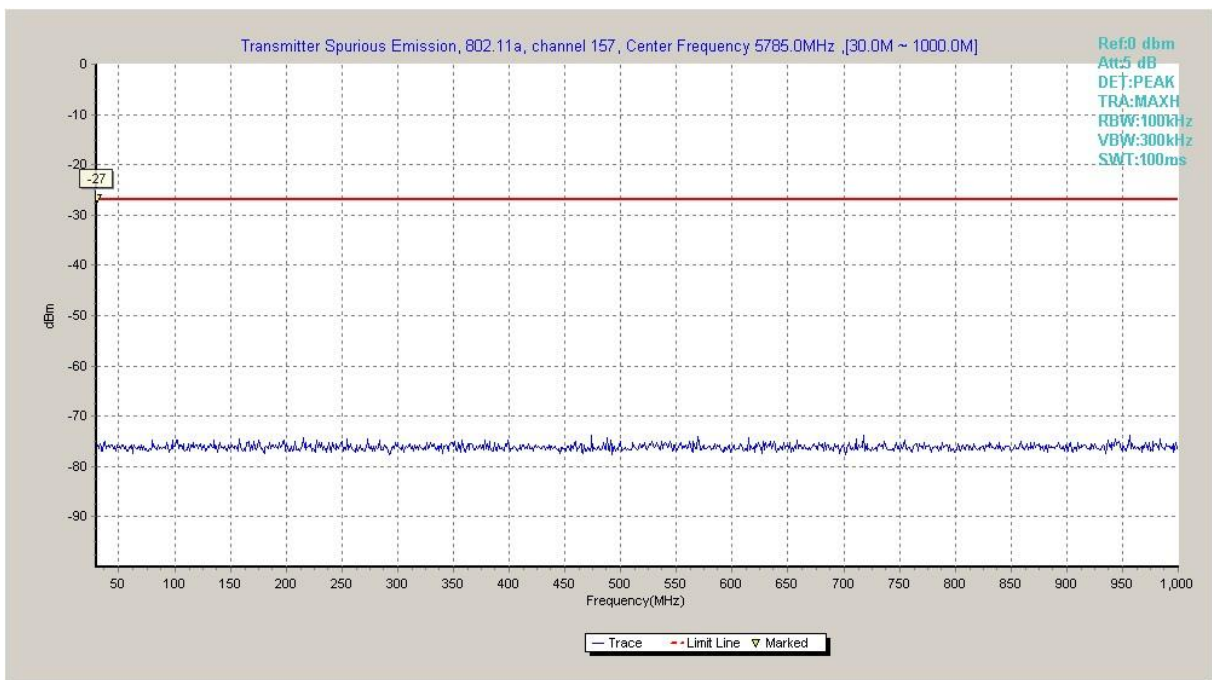

Fig. 19 Conducted Spurious Emission (802.11a, Ch157, 30 MHz-1 GHz)

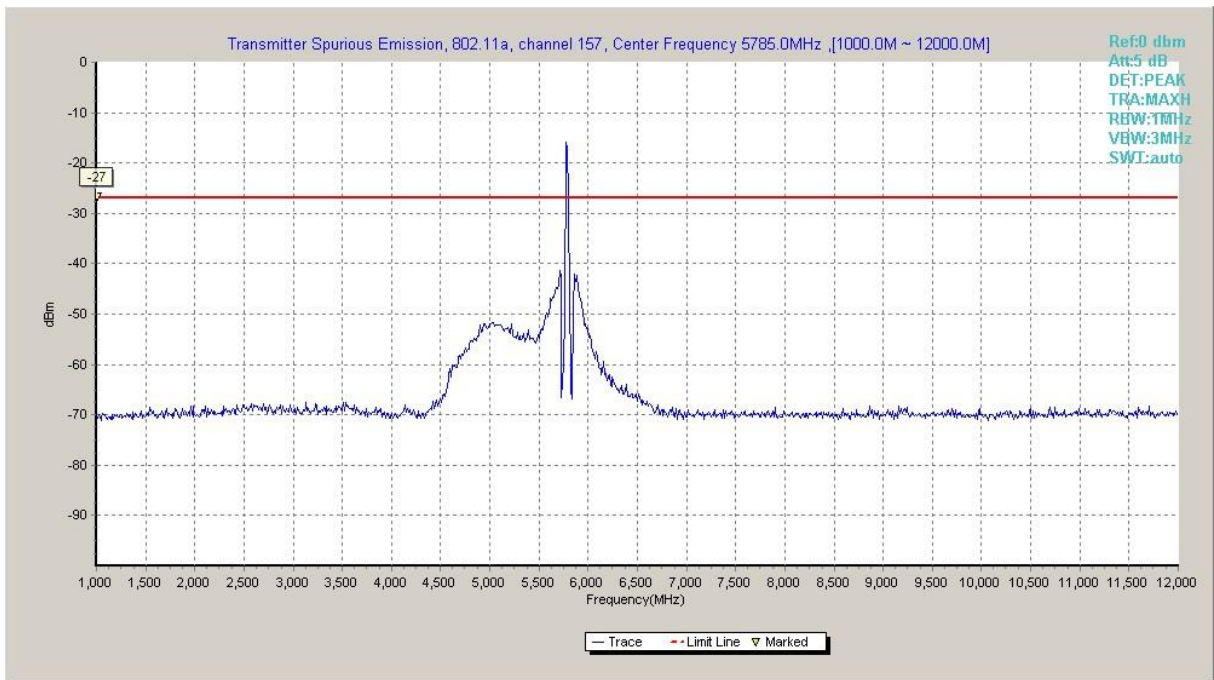

Fig. 20 Conducted Spurious Emission (802.11a, Ch157, 1 GHz -12 GHz)

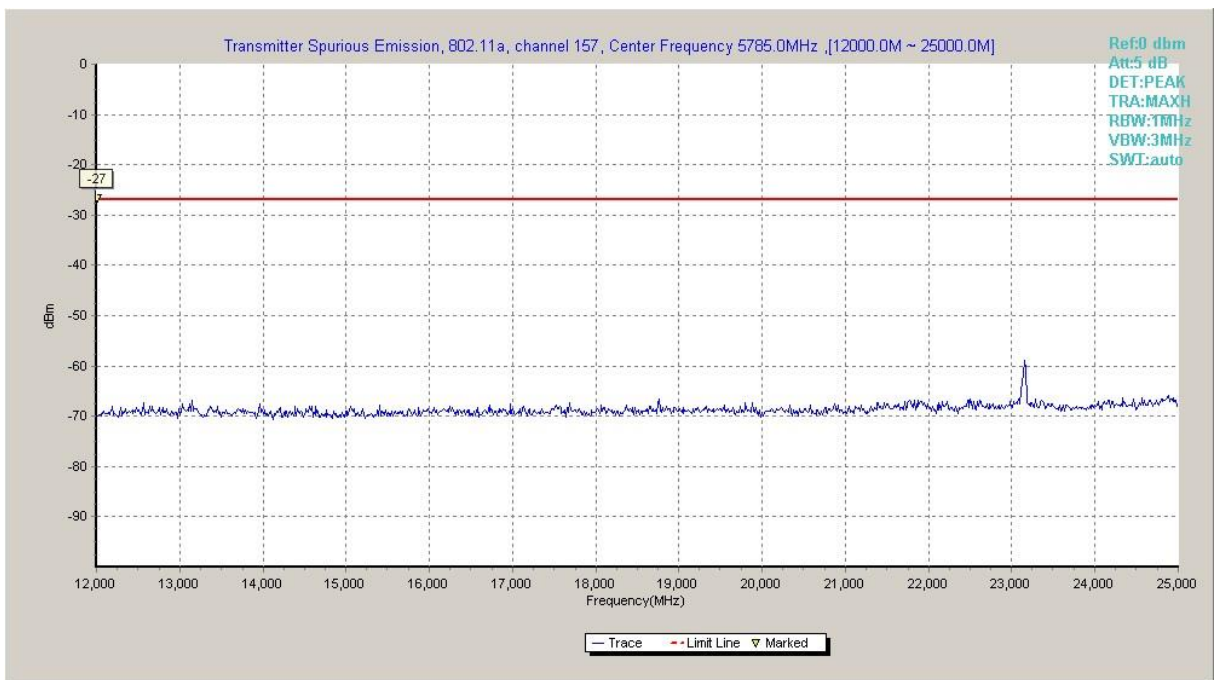

Fig. 21 Conducted Spurious Emission (802.11a, Ch157, 12 GHz-25 GHz)

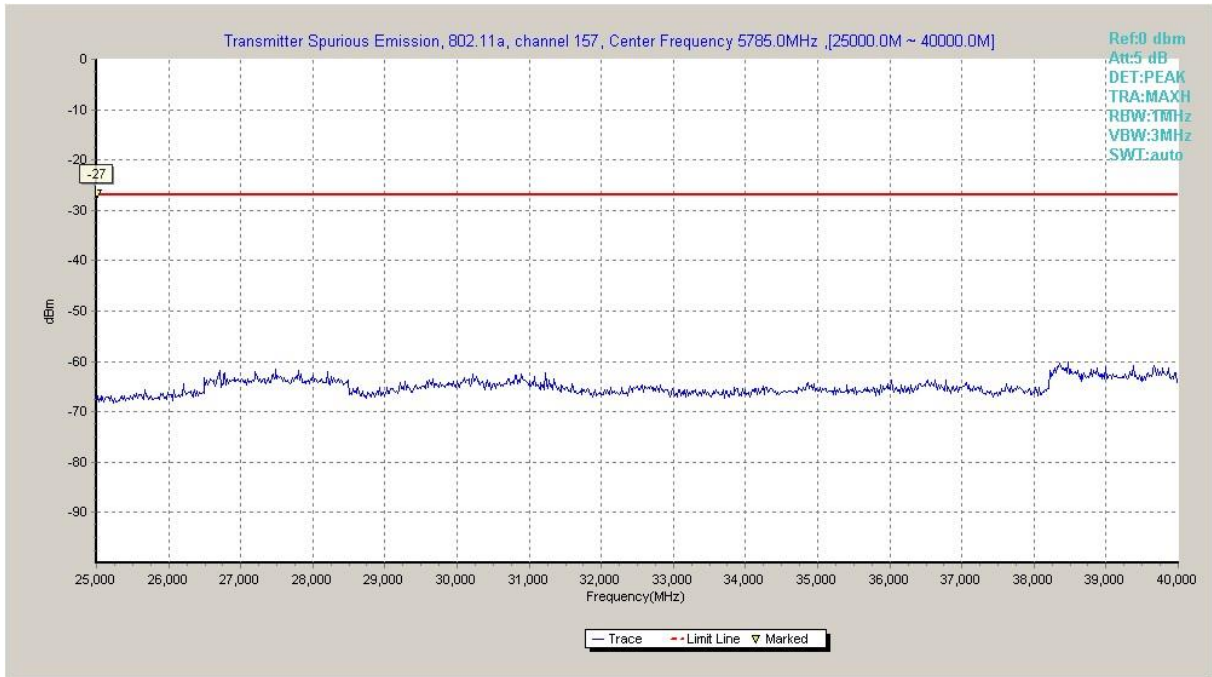

Fig. 22 Conducted Spurious Emission (802.11a, Ch157, 25 GHz-40 GHz)

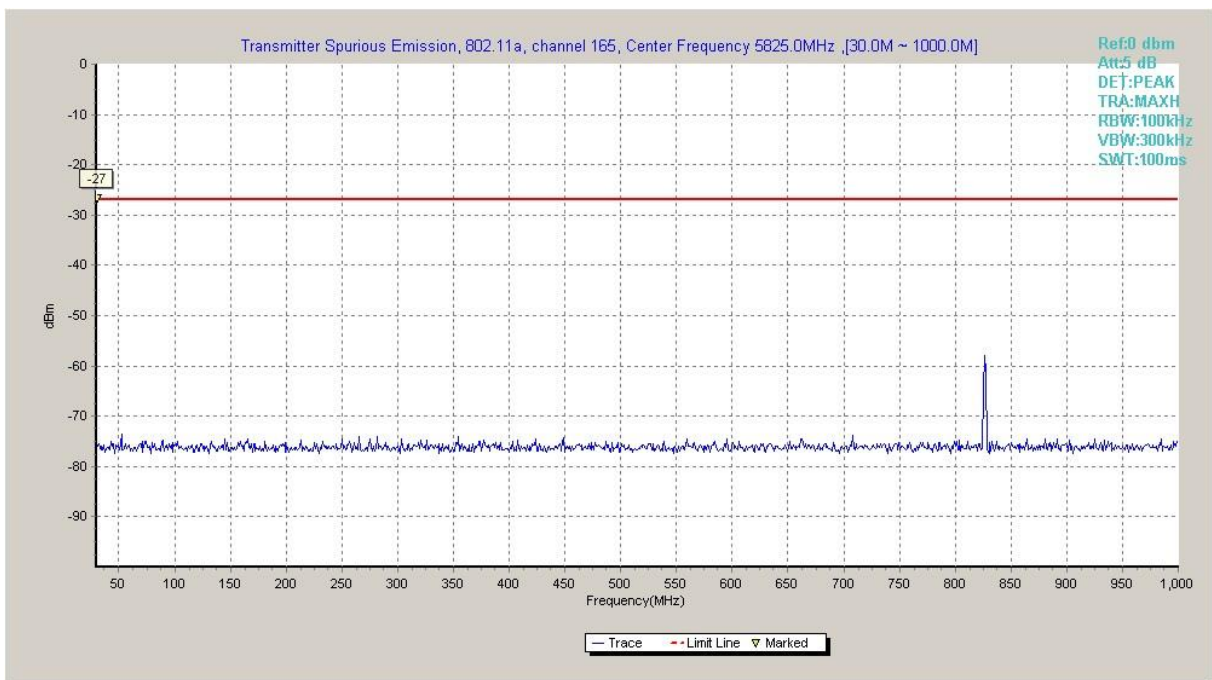

Fig. 23 Conducted Spurious Emission (802.11a, Ch165, 30 MHz-1 GHz)

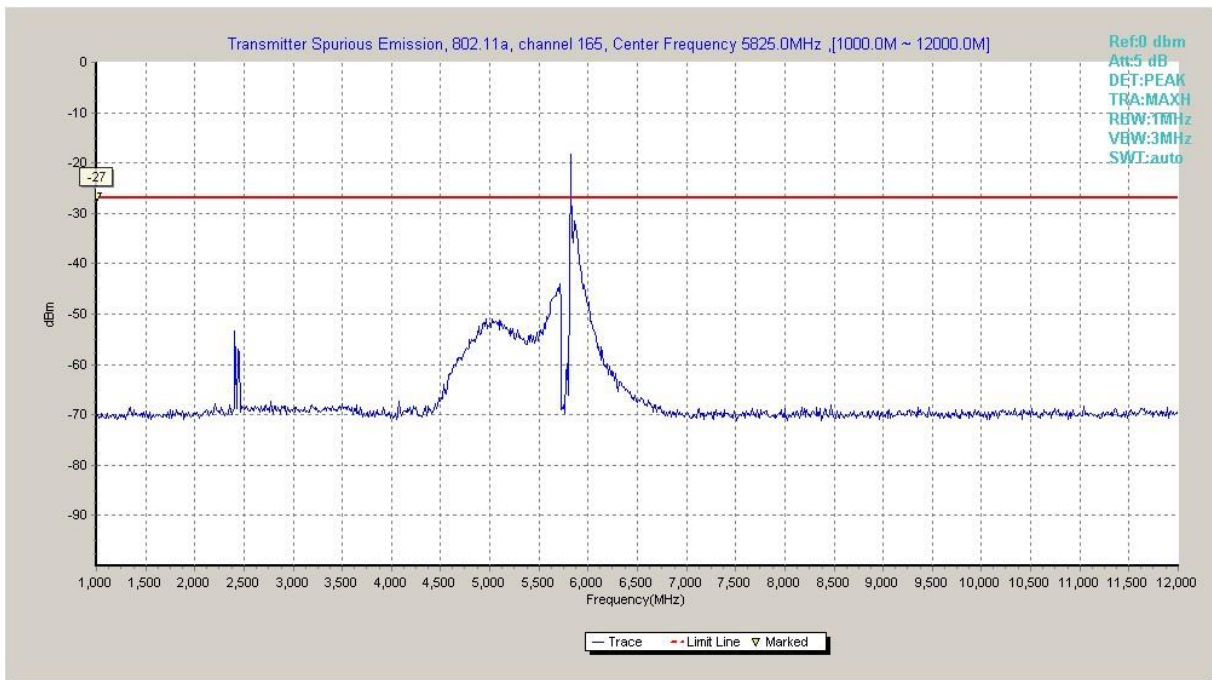

Fig. 24 Conducted Spurious Emission (802.11a, Ch165, 1 GHz -12 GHz)

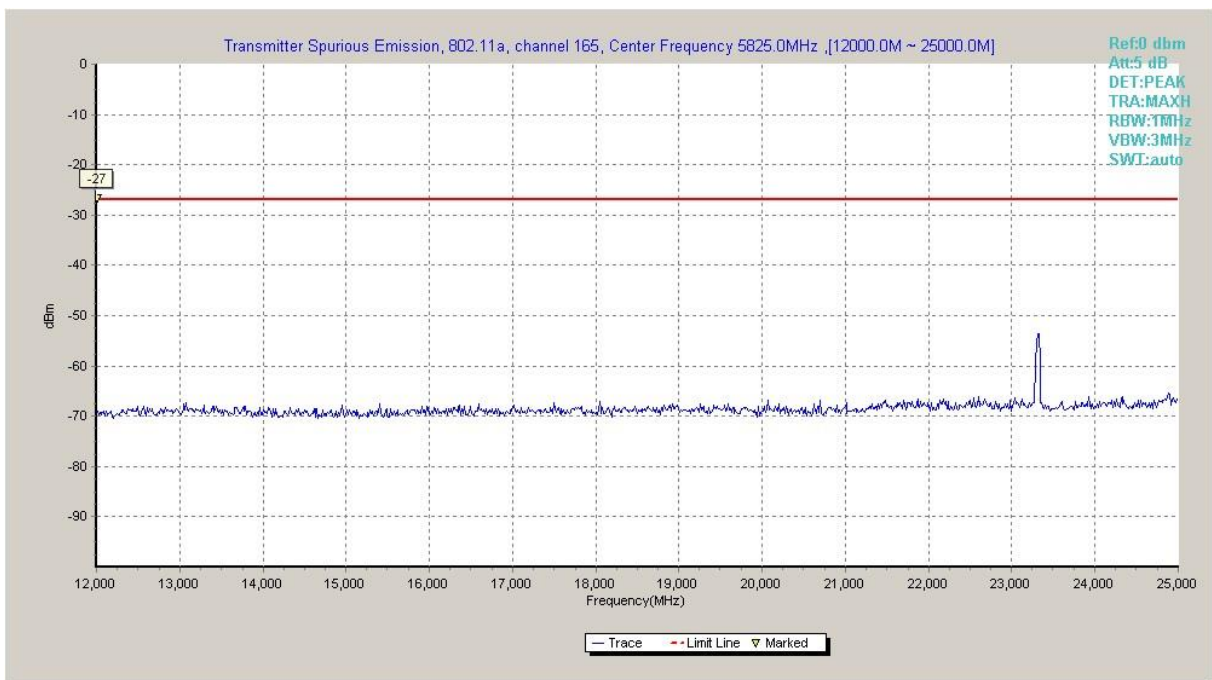

Fig. 25 Conducted Spurious Emission (802.11a, Ch165, 12 GHz-25 GHz)

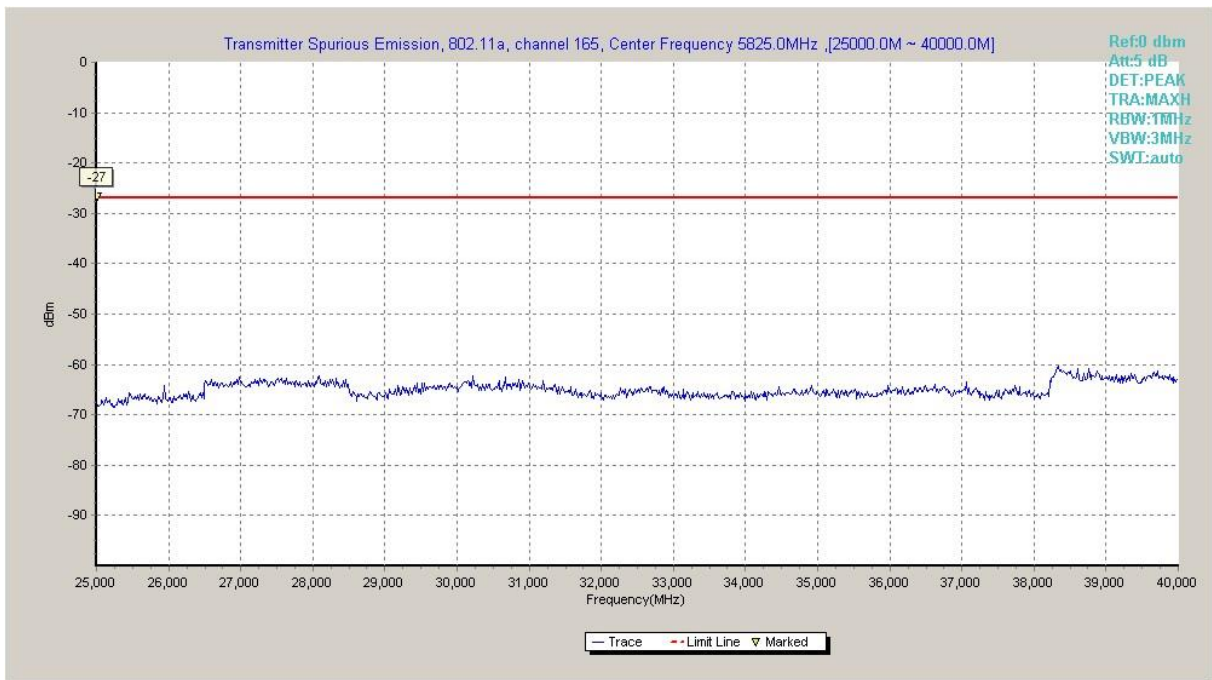

Fig. 26 Conducted Spurious Emission (802.11a, Ch165, 25 GHz-40 GHz)

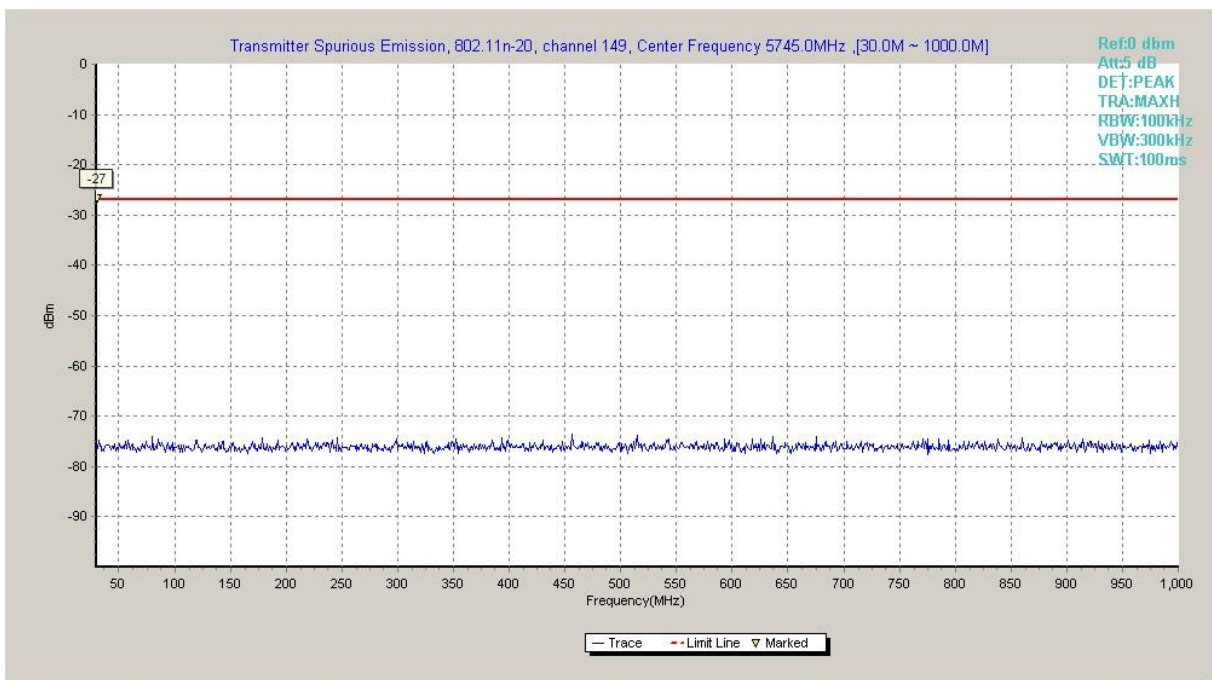

Fig. 27 Conducted Spurious Emission (802.11n-HT20, Ch149, 30 MHz-1 GHz)

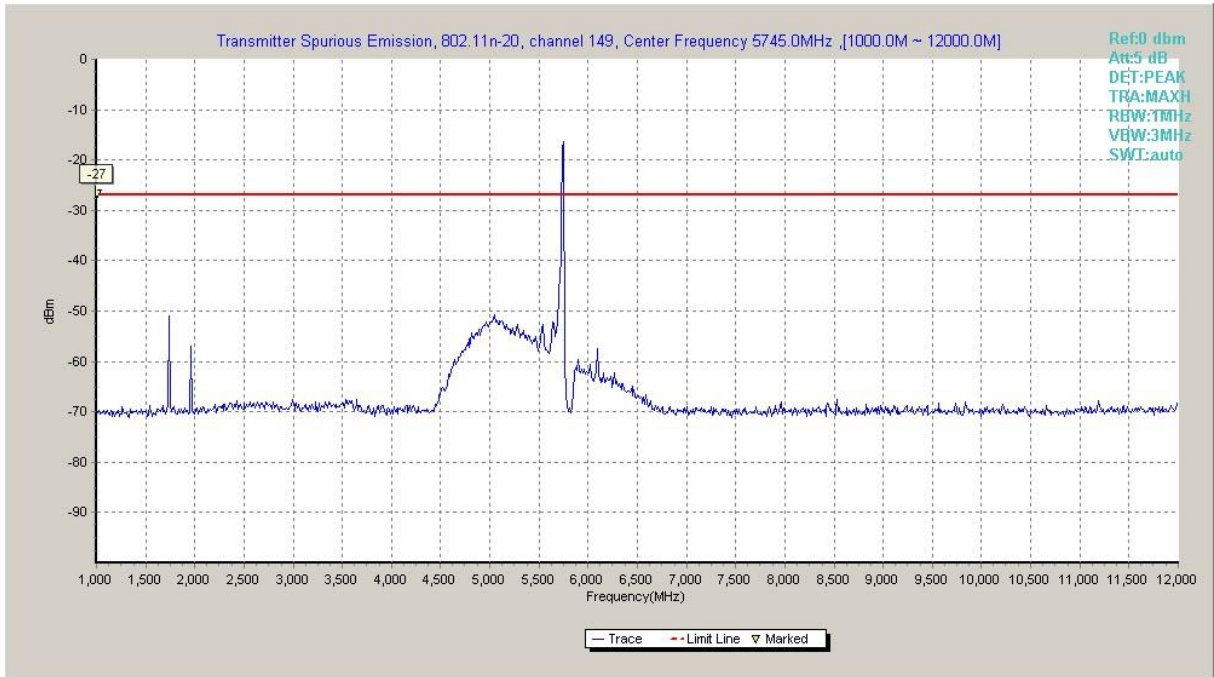

Fig. 28 Conducted Spurious Emission (802.11n-HT20, Ch149, 1 GHz -12 GHz)

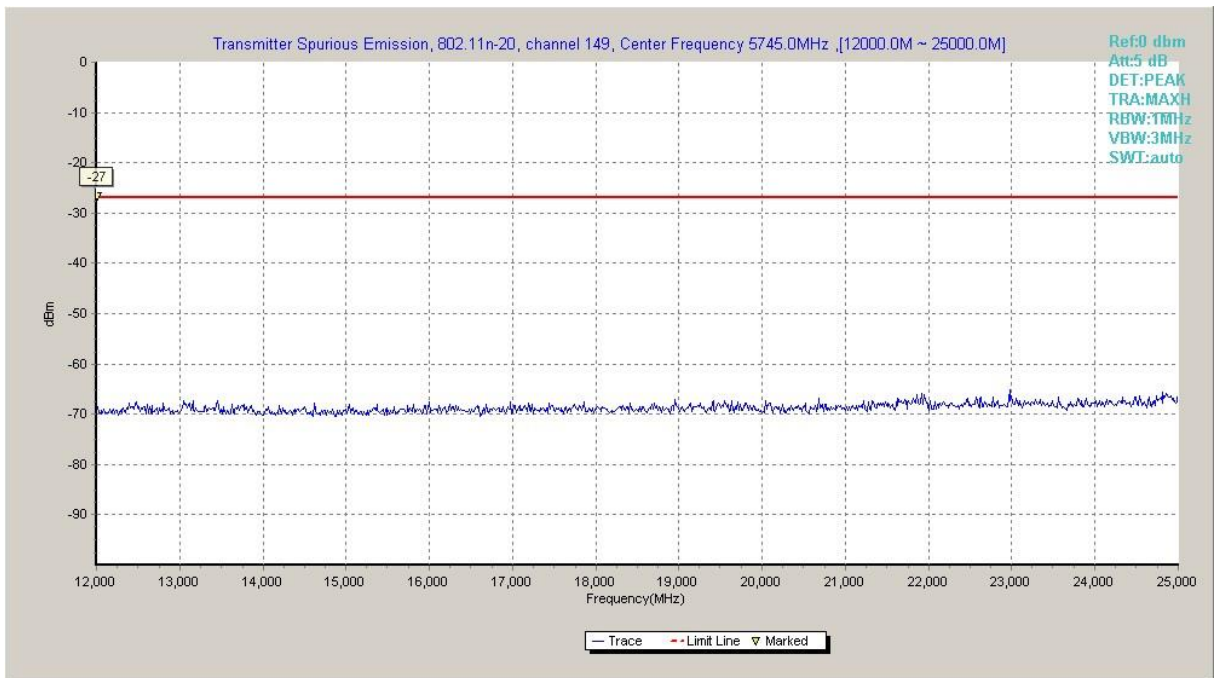

Fig. 29 Conducted Spurious Emission (802.11n-HT20, Ch149, 12 GHz-25 GHz)

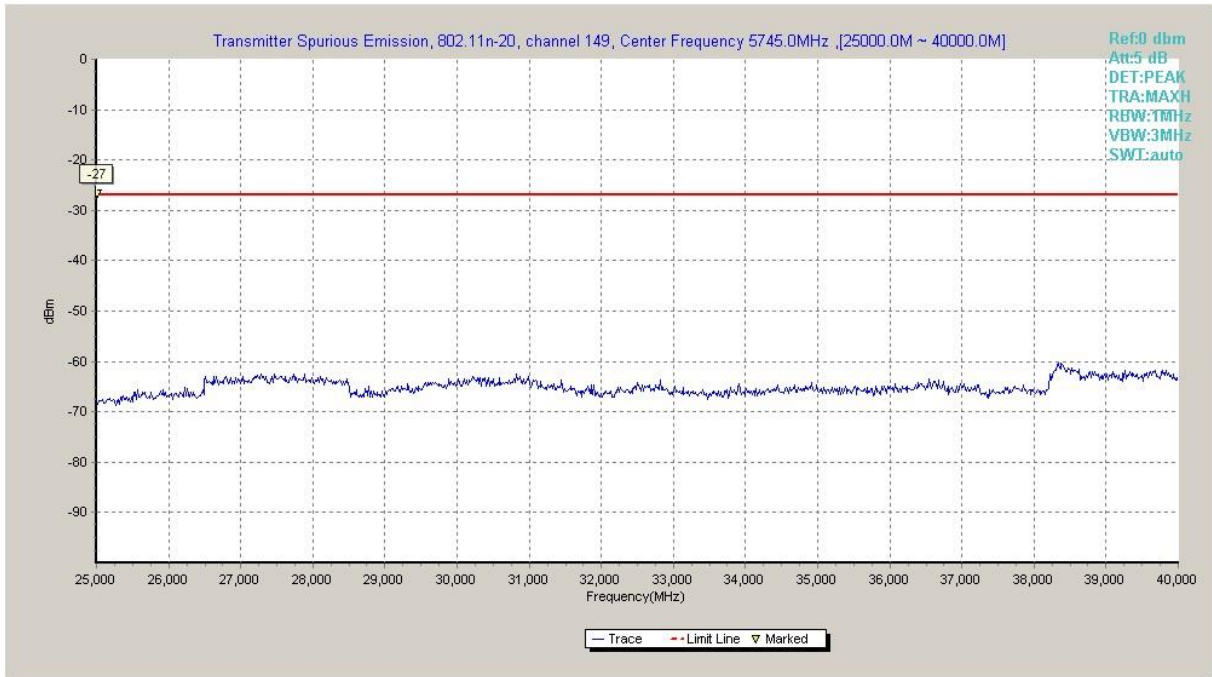

Fig. 30 Conducted Spurious Emission (802.11n-HT20, Ch149, 25 GHz-40 GHz)

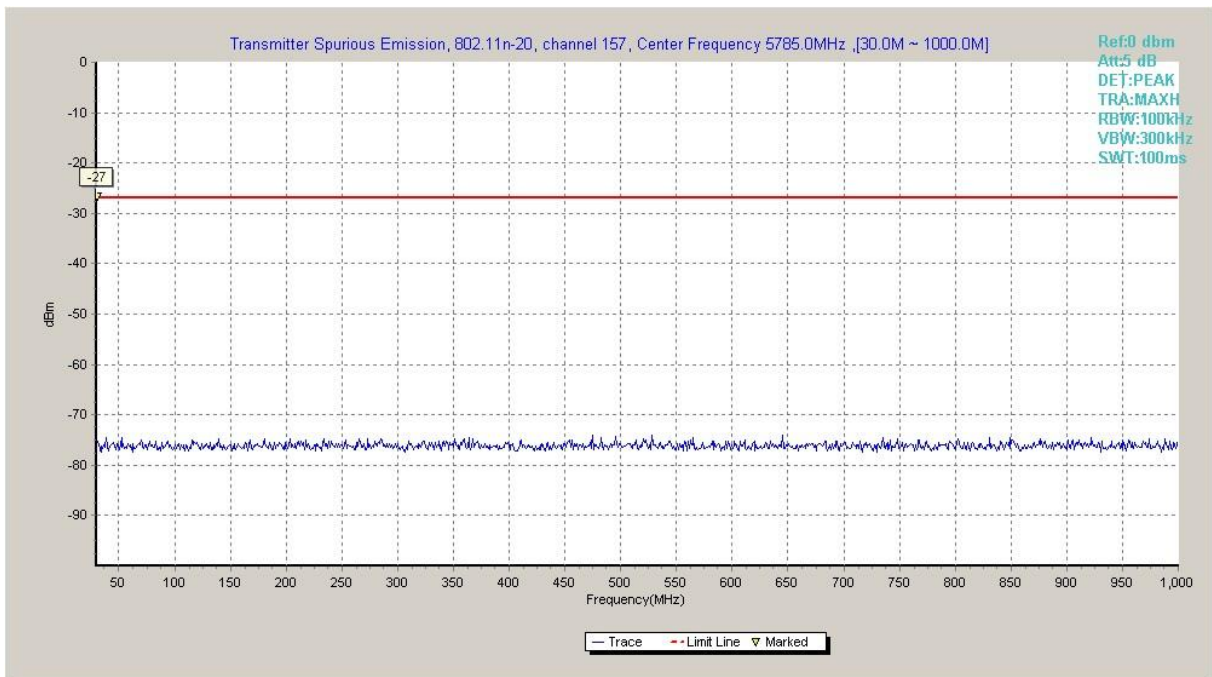

Fig. 31 Conducted Spurious Emission (802.11n-HT20, Ch157, 30 MHz-1 GHz)

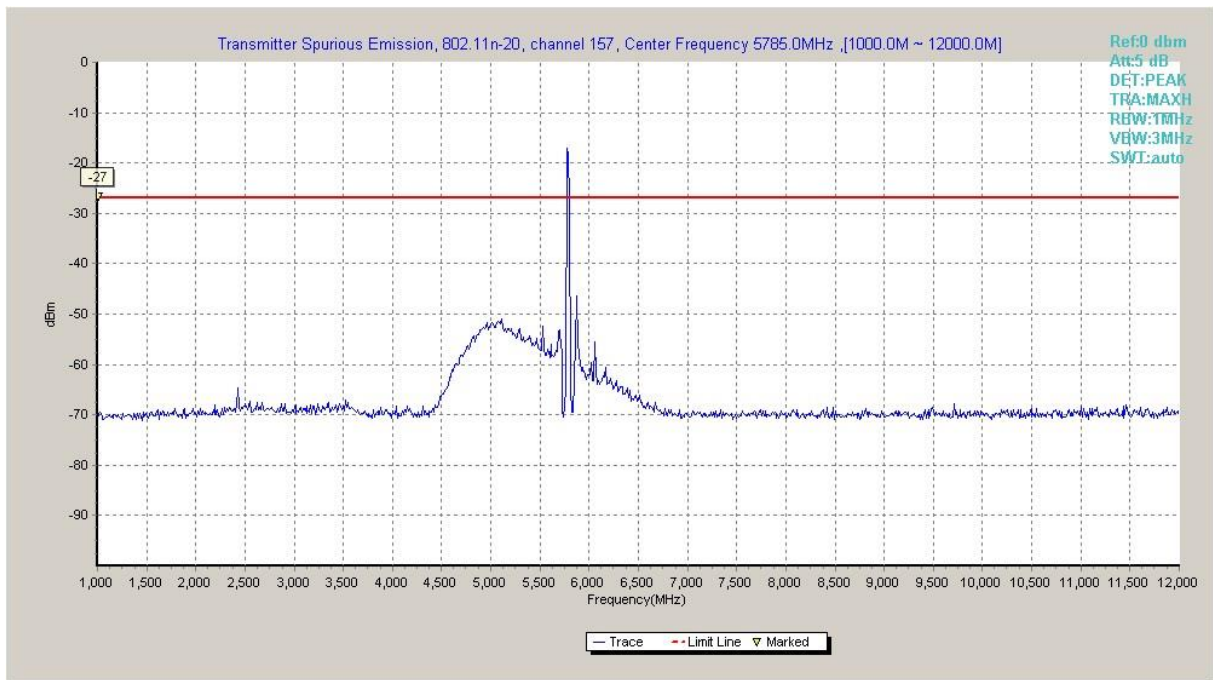

Fig. 32 Conducted Spurious Emission (802.11n-HT20, Ch157, 1 GHz -12 GHz)

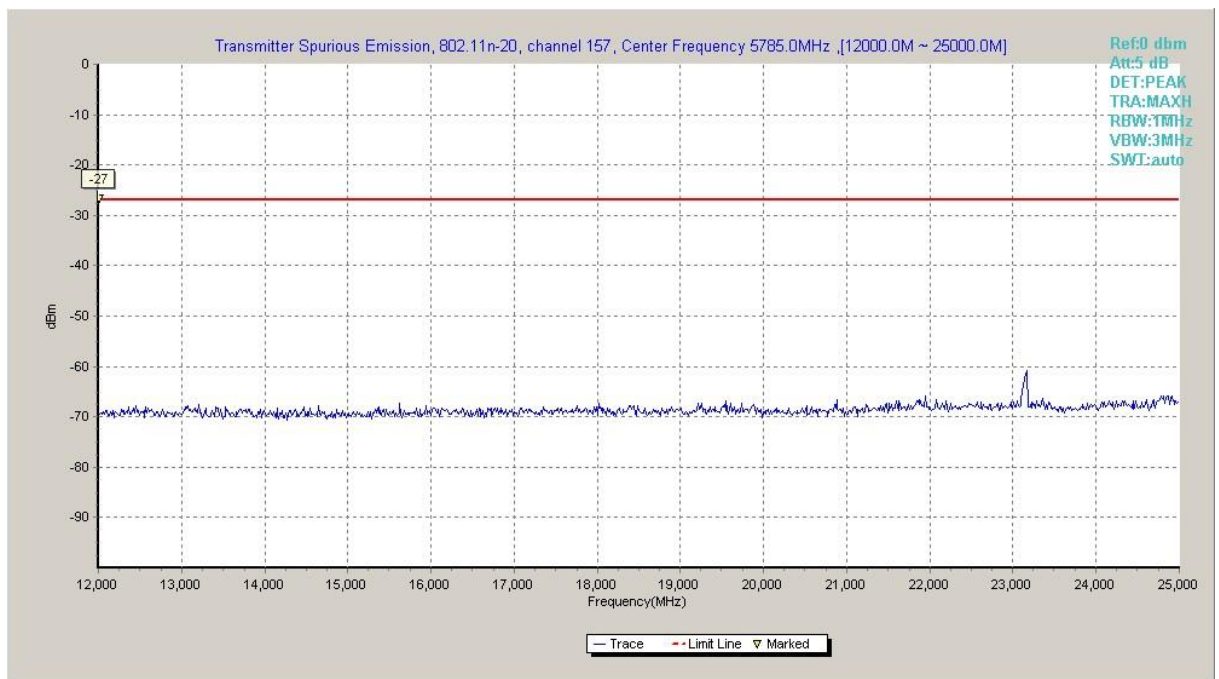

Fig. 33 Conducted Spurious Emission (802.11n-HT20, Ch157, 12 GHz-25 GHz)

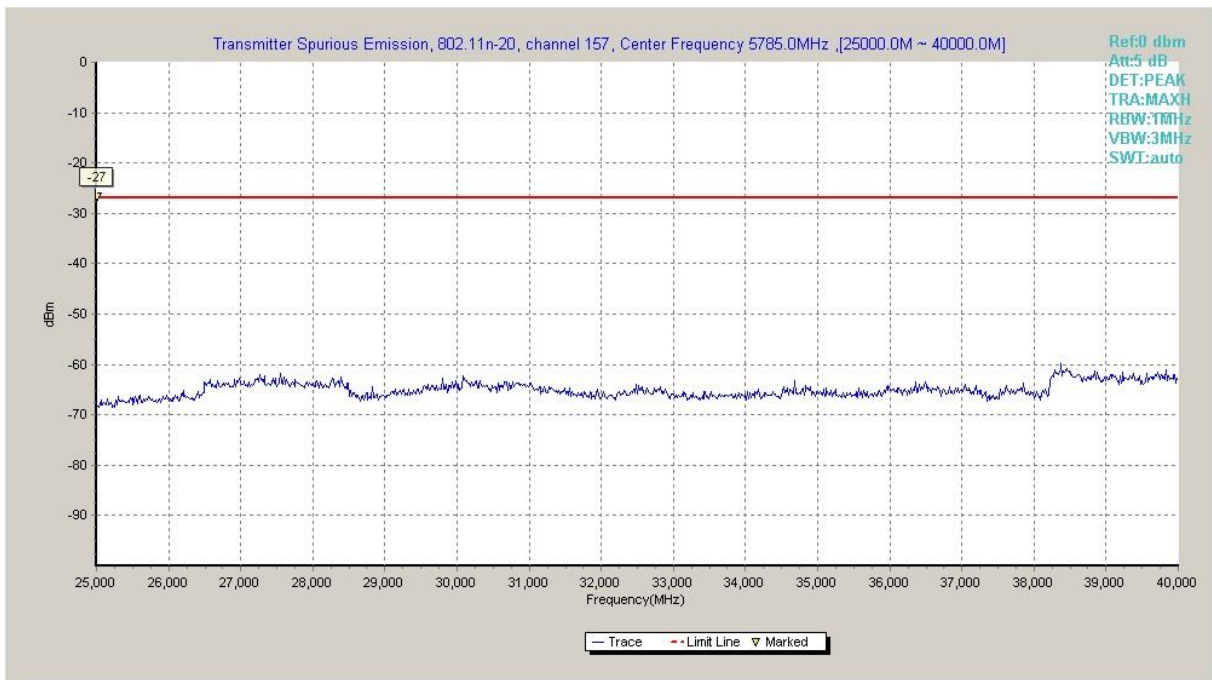

Fig. 34 Conducted Spurious Emission (802.11n-HT20, Ch157, 25 GHz-40 GHz)

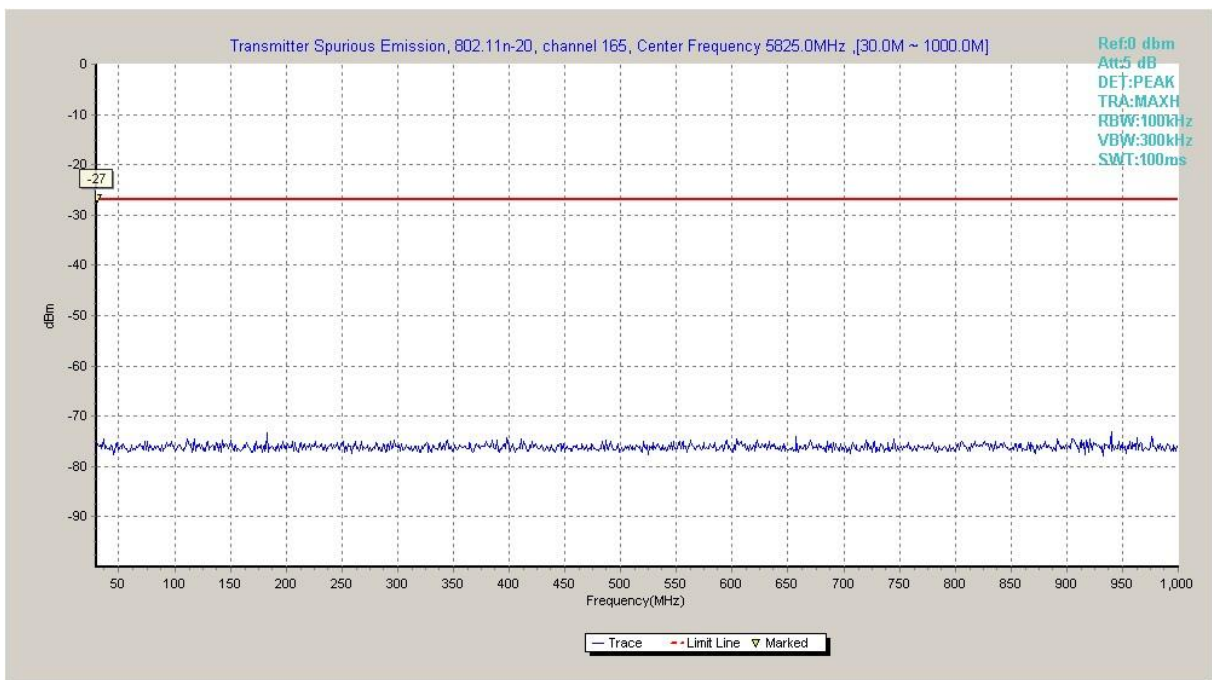

Fig. 35 Conducted Spurious Emission (802.11n-HT20, Ch165, 30 MHz-1 GHz)

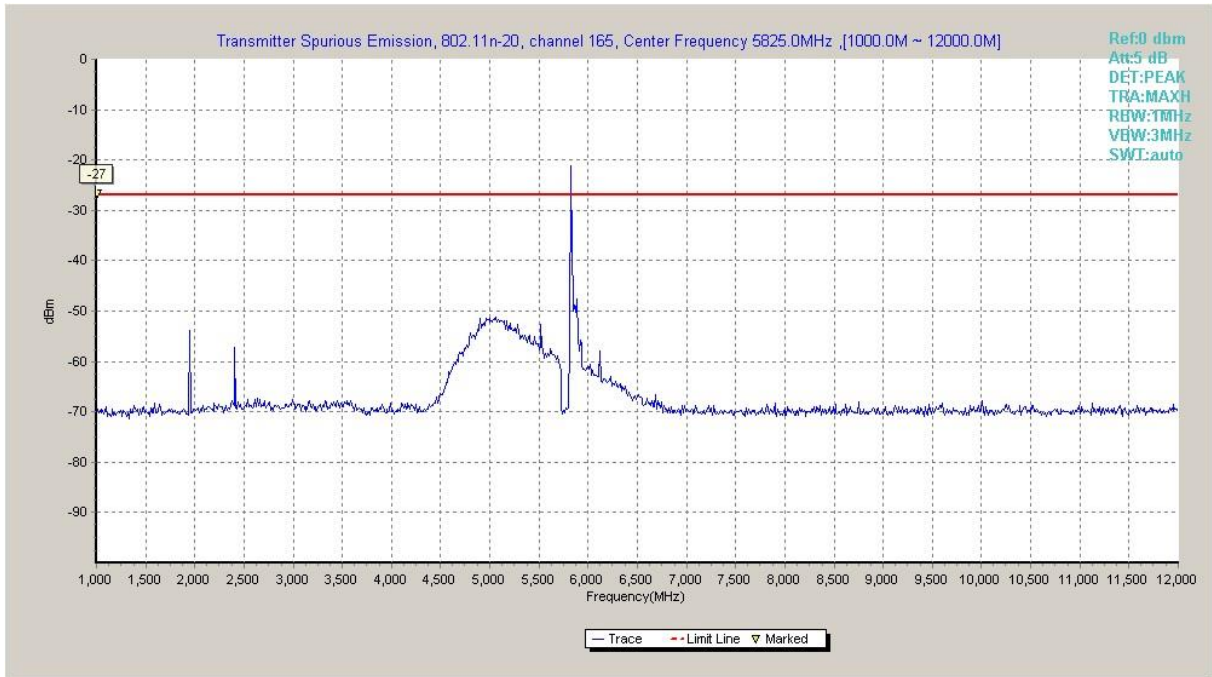

Fig. 36 Conducted Spurious Emission (802.11n-HT20, Ch165, 1 GHz -12 GHz)

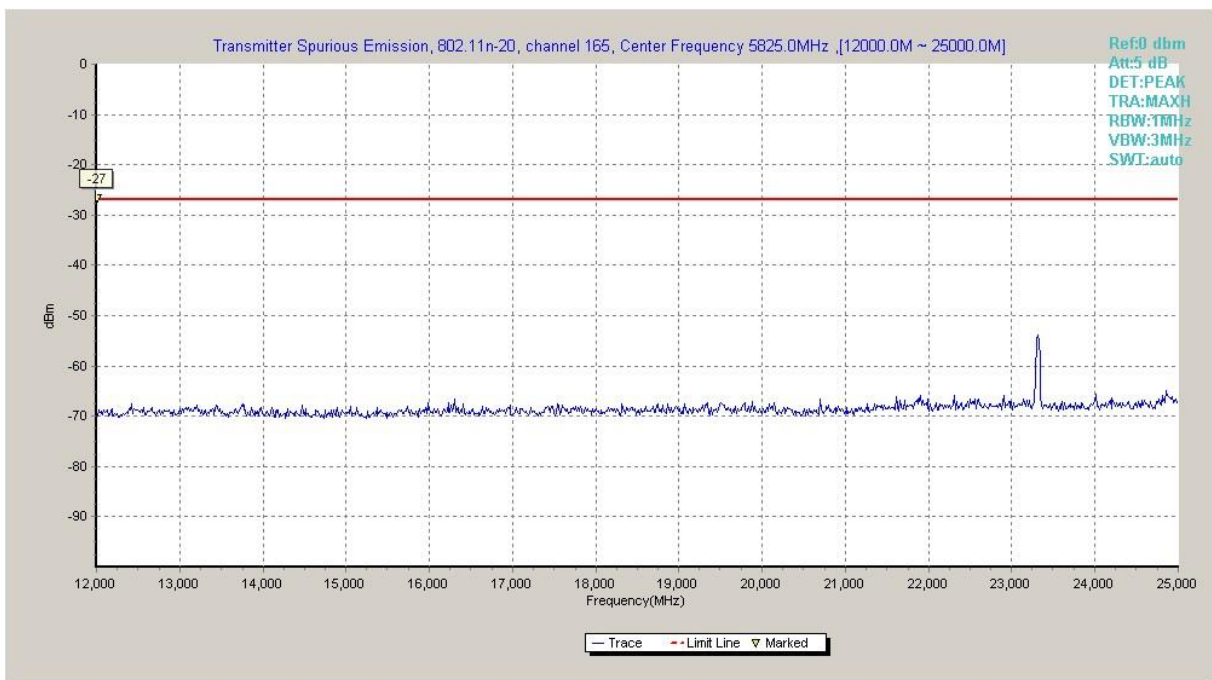

Fig. 37 Conducted Spurious Emission (802.11n-HT20, Ch165, 12 GHz-25 GHz)

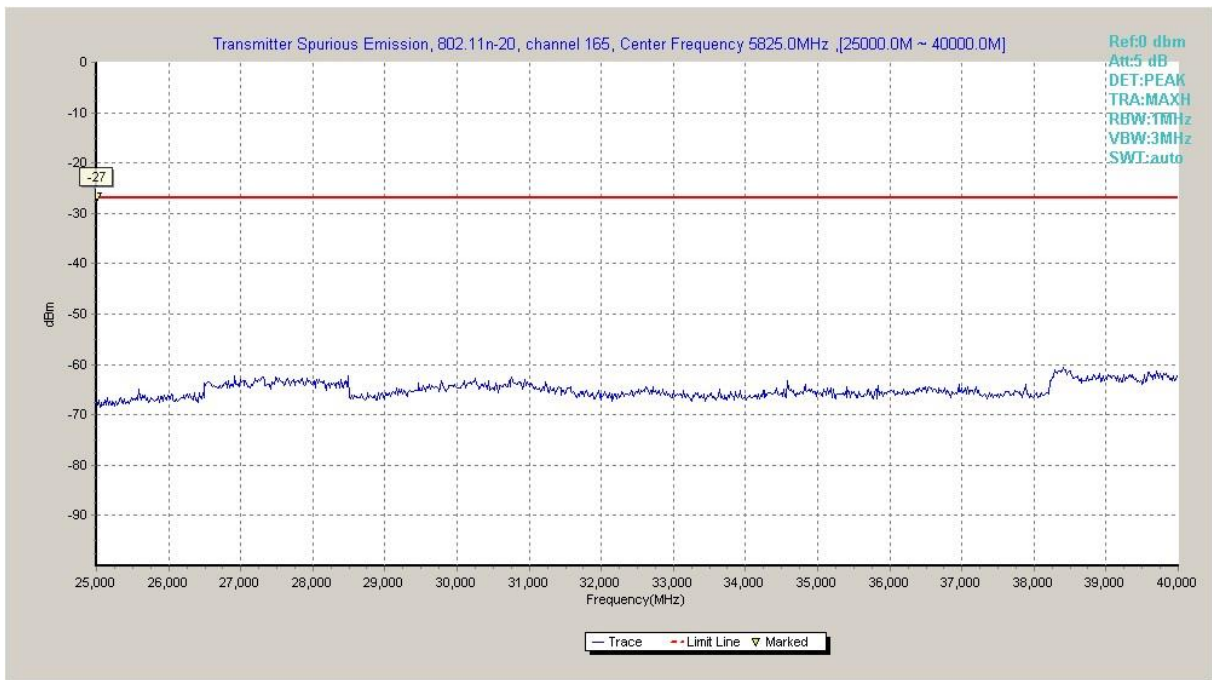

Fig. 38 Conducted Spurious Emission (802.11n-HT20, Ch165, 25 GHz-40 GHz)

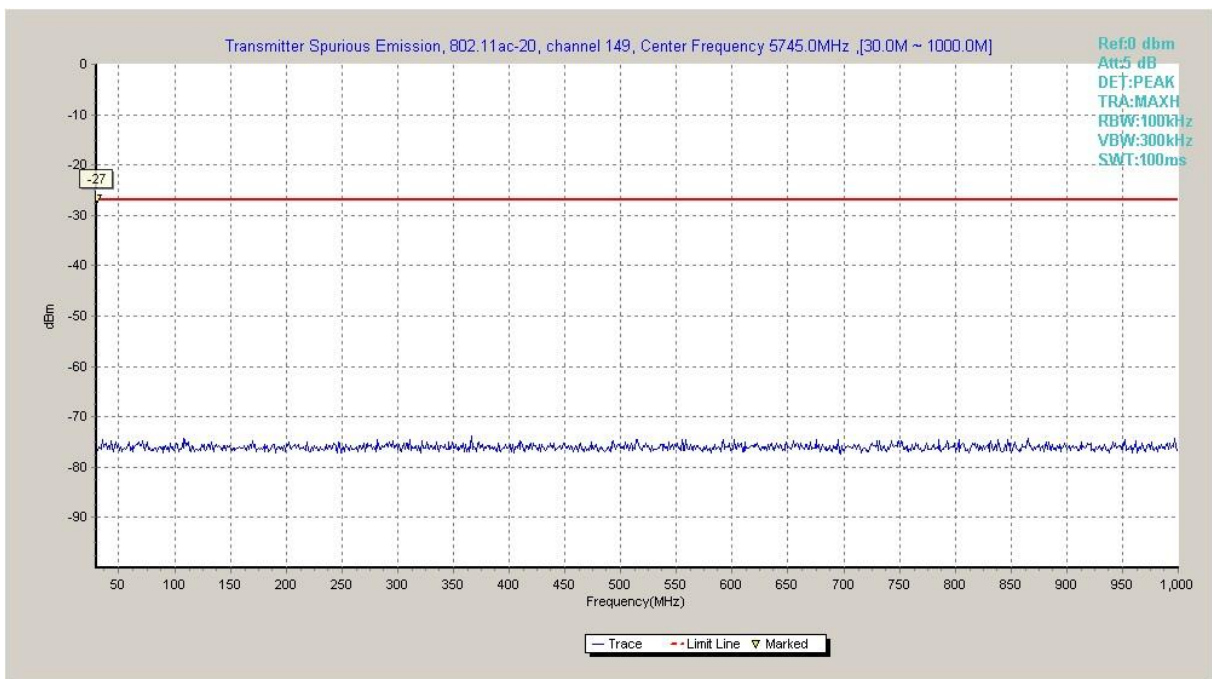

Fig. 39 Conducted Spurious Emission (802.11ac-HT20, Ch149, 30 MHz-1 GHz)

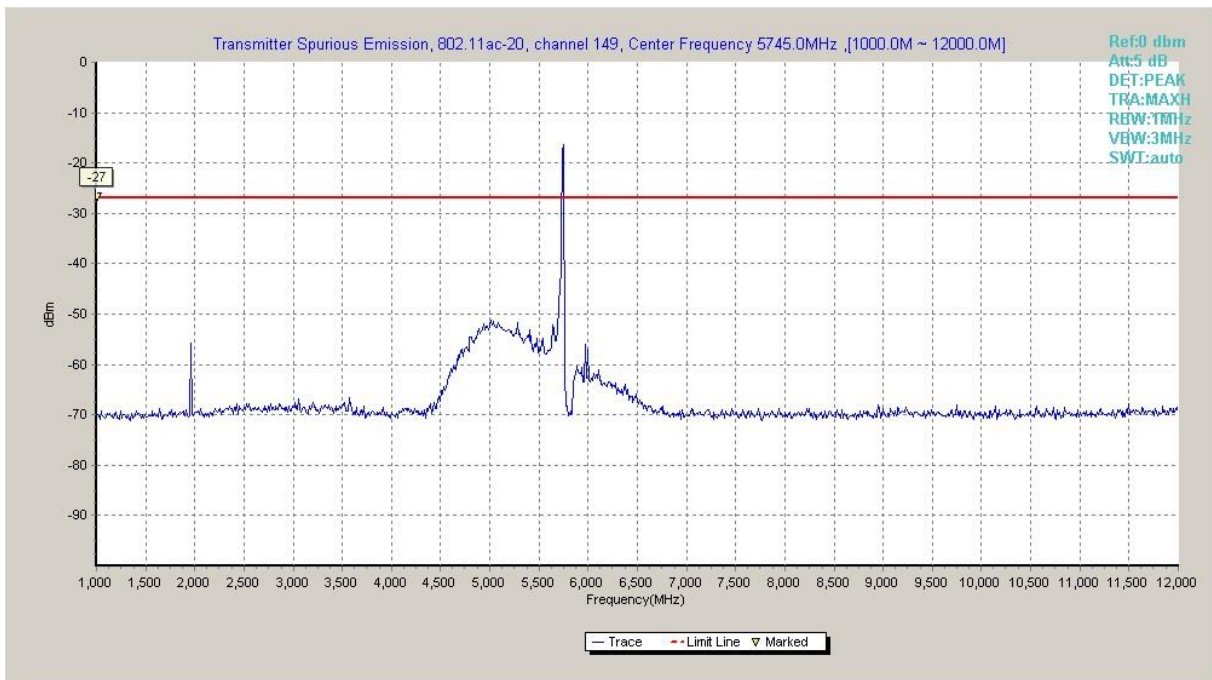

Fig. 40 Conducted Spurious Emission (802.11ac-HT20, Ch149, 1 GHz -12 GHz)

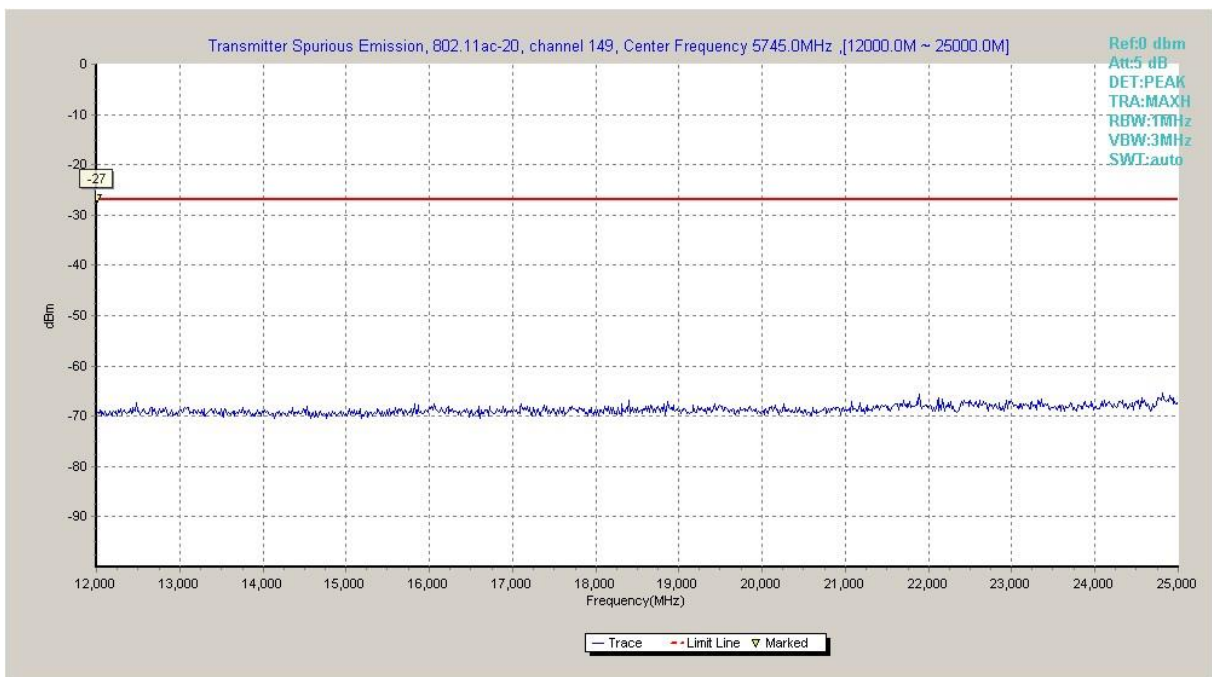

Fig. 41 Conducted Spurious Emission (802.11ac-HT20, Ch149, 12 GHz-25 GHz)

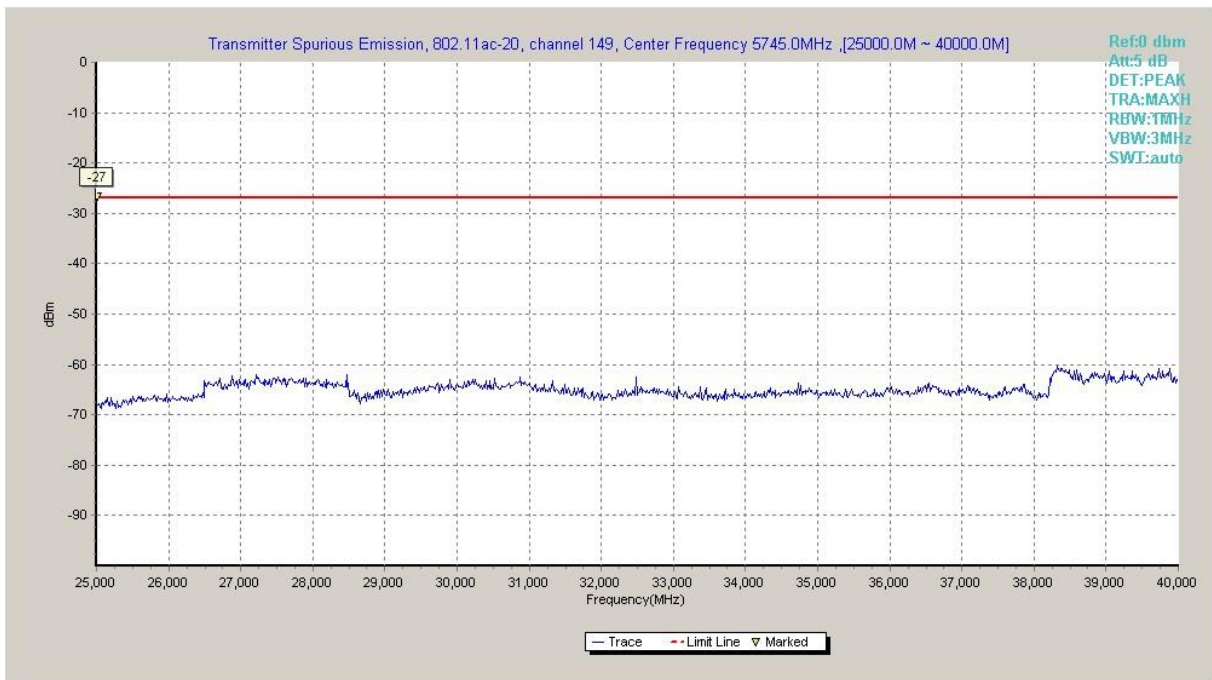

Fig. 42 Conducted Spurious Emission (802.11ac-HT20, Ch149, 25 GHz-40 GHz)

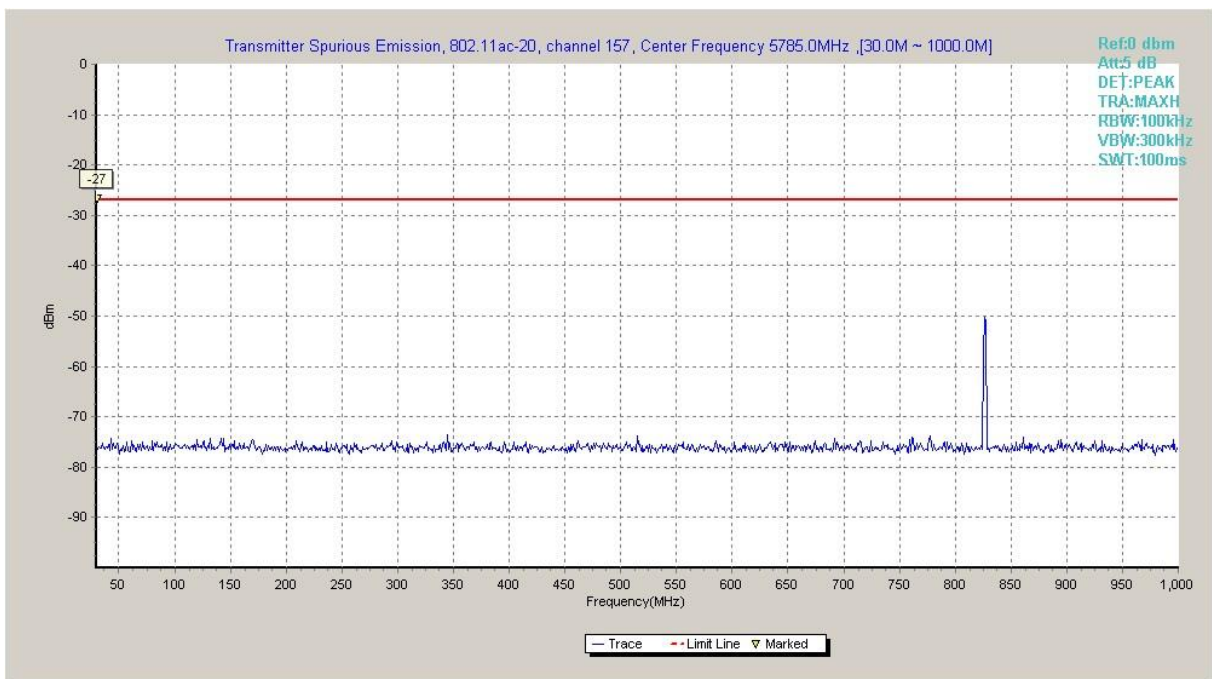

Fig. 43 Conducted Spurious Emission (802.11ac-HT20, Ch157, 30 MHz-1 GHz)