

**Notes:**

Barcode of type 128 A & C containing "l4ffdddnnnyaaaac", where l is written with 128A the rest with 128C.

Unit Label: Label blank art. no. 59553

Quiet zone	min. 2.54 mm on each side.
Bar height	4 mm.
Barcode length	Barcode width is up to 25.1 mm.
Id. string height	1.5 mm.
Info. line height	1.5 mm.
Info. 2 line height	1.5 mm.
CE mark height	5 mm.
WEEE symbol height	7 mm.
FCC mark height	3 mm.
SGS mark height	5 mm.
Tick mark height	3 mm.
UKCA mark height	5 mm.
Barcode placement	The print should be centered lengthwise on the label and placed 0.5 mm from top edge

**Variable fields:**

Identifier string:

l	Revision level. One upper case letter (A-Z).
'4'	Format identifier. Always 4 for PL.
ff	Manufacturing unit. Two digits (00-64)
ddd	Production date. Three digits (000-953). Year followed by week (713= 1997 week 13, 650= 2006 week 50).
nnny	Serial number. Five digits (00000-65535). Reset every new week.
aaaa	PL type. Four digits (0000-9999).
c	Checksum. One digit (0-9). The modulo-10 value of the sum of ASCII value for all 16 preceding characters.

The ff, ddd and nnnny fields together forms the physical addresses. Within one week, each manufacturing unit must use a continuous serial number, irregardless of if a switch to a new PL is done. Otherwise the physical address will not be unique!

**Under no circumstances can the serial number be set to zero, except when changing the week number!**

Information line:

ppppp-pp	Product number. Printed by five plus two (optional) decimal digits in the range 00000-00 - 99999-99. Not derived from the bar code.
yyww	Manufacturing date. Is derived from ddd in the barcode and printed as four digits in the range yyww, indicating year and week.
<A>	Option field. Any printable characters.

Information line 2:

Made in	Manufacturing country. Printed as Made in followed by country. Not derived from barcode.
---------	---

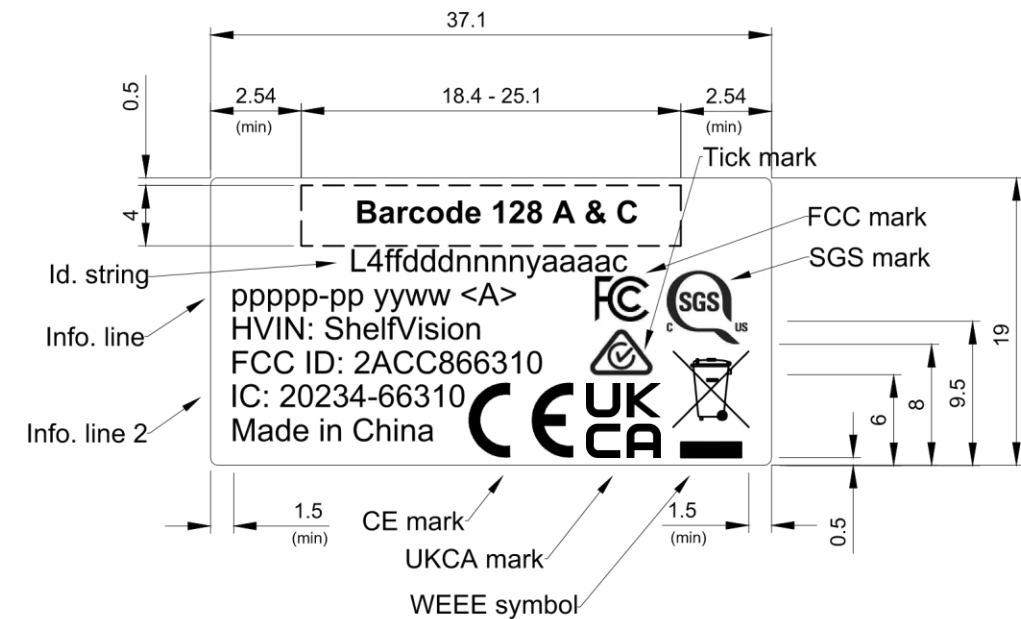

Produkt/Product							
Material/värmebeh./Heat Treatment		Ytbeläggning/Surface coating					
		Allmänna best./General requirements					
<b>PRICER</b>	Ytjämn./Surf.roughn	Grad.pol./Deburr.pol.	Konstr./Design.	Kontr./Chd.	Gransk./Std.	Godk./Appd.	Blad nr./Sheet
			EMC				1/1
	Filnamn/File name	Skala/Scale	Upprätt.datum/Original date	Rev.datum/Rev.date	Rev.		
	102-51400e.dwg	2:1	201207	210510	E		
Benämning/Name			Dok.typ/Doc.type	Artikelnr./Article no.			
Labelling instruction ShelfVision			102	51400			

This document is our property and shall not without our permission in writing be altered, copied, used for manufacturing or communicated to any other person or company.

Denna handling är vår egendom och får ej utan vårt skriftliga medgivande ändras, kopieras, användas för tillverkning eller delges annan person eller firma.



Comments -		Scale 1:1	Units mm	Format A4
Prepared Fredrik Tjerneld/210506		Product label position Pricer ShelfVision		
Reviewed -				Language EN/SV
Approved -				Page 1 of 1
		Document id.	Revision A	