

TEST REPORT
No.: 19-1-0103601T07a-C1

According to:
Title 47 CFR, Chapter I
FCC Regulations, Subchapter A
§15.247 (DTS)

ISED-Regulations
RSS-Gen, Issue 5
RSS 247 Issue 2
(DTS)

for

Continental Advanced Antenna GmbH

TRANSCVRP02
BT-Transceiver

FCC ID: 2ACC7TRANSCVRP02
ISED ID: 11980A-TRANSCVRP02

Laboratory Accreditation and Listings



Accredited EMC-Test Laboratory

accredited according to DIN EN ISO/IEC 17025

CETECOM GmbH

Laboratory Radio Communications & Electromagnetic Compatibility
Im Teelbruch 116 • 45219 Essen • Germany
Registered in Essen, Germany, Reg. No.: HRB Essen 8984
Tel.: + 49 (0) 20 54 / 95 19-954 • Fax: + 49 (0) 20 54 / 95 19-964
E-mail: info@cetecom.com • Internet: www.cetecom.com

Table of contents

| | |
|---|-----------|
| 1. SUMMARY OF TEST RESULTS..... | 3 |
| 1.1. Tests measurement overview according of US CFR Title 47, Subpart 15C and Canada RSS-Standards: ... | 3 |
| 1.2. Attestation:..... | 4 |
| 2. ADMINISTRATIVE DATA | 6 |
| 2.1. Identification of the testing laboratory..... | 6 |
| 2.2. Test location | 6 |
| 2.3. Organizational items..... | 6 |
| 2.4. Applicant’s details | 6 |
| 2.5. Manufacturer’s details | 6 |
| 3. EQUIPMENT UNDER TEST (EUT)..... | 7 |
| 3.1. TECHNICAL DATA OF MAIN EUT DECLARED BY..... | 7 |
| 3.2. EUT: Type, S/N etc. and short descriptions used in this test report | 7 |
| 3.3. Auxiliary Equipment (AE): Type, S/N etc. and short descriptions..... | 8 |
| 3.4. EUT set-ups | 8 |
| 3.5. EUT operating modes | 8 |
| 3.6. Test Settings | 9 |
| 3.7. Test Software | 9 |
| 3.8. Configuration of cables used for testing | 9 |
| 3.9. Worst Case Selection | 9 |
| 4. DESCRIPTION OF TEST SYSTEM SET-UP’S | 10 |
| 4.1. Test system set-up for conducted measurements on antenna port | 10 |
| 4.2. Test system set-up for radiated magnetic field measurements below 30 MHz..... | 11 |
| 4.3. Test system set-up for radiated electric field measurement 30 MHz to 1 GHz | 12 |
| 4.4. Test system set-up for radiated electric field measurement above 1 GHz | 13 |
| 5. MEASUREMENTS | 14 |
| 5.1. Duty-Cycle..... | 14 |
| 5.2. RF-Parameter - 6 dB Bandwidth and 99% occupied bandwidth | 15 |
| 5.3. Maximum peak conducted output power..... | 17 |
| 5.4. RF-Parameter - Power Spectral Density | 20 |
| 5.5. 20 dBc power specification..... | 21 |
| 5.6. General Limit - Radiated field strength emissions below 30 MHz..... | 23 |
| 5.7. General Limit - Radiated field strength emissions, 30 MHz - 1 GHz..... | 26 |
| 5.8. General Limit – Radiated field strength emissions, above 1 GHz..... | 29 |
| 5.9. Radiated Band-Edge compliance, field strength measurements accord. §15.205..... | 31 |
| 5.10. Measurement uncertainties | 32 |
| 6. ABBREVIATIONS USED IN THIS REPORT | 33 |
| 7. ACCREDITATION DETAILS OF CETECOM’S LABORATORIES AND TEST SITES | 33 |
| 8. INSTRUMENTS AND ANCILLARY | 34 |
| 8.1. Used equipment “CTC” | 34 |
| 9. VERSIONS OF TEST REPORTS (CHANGE HISTORY) | 38 |

| Table of Annex | | | |
|---|-----------------------------|-------------------------------|-------------|
| Annex No. | Contents | Reference Description | Total Pages |
| Annex 1 | Test results | CETECOM_TR19-1-0103601T07a_A1 | 45 |
| Annex 2 | External photographs of EUT | CETECOM_TR19-1-0103601T07a_A2 | 8 |
| Annex 3 | Test set-up photographs | CETECOM_TR19-1-0103601T07a_A3 | 7 |
| The listed attachments are an integral part of this report. | | | |
| *) For Internal photographs of EUT, see applicant’s documentation | | | |

1. Summary of test results

The test results apply exclusively to the test samples as presented in this Report. The CETECOM GmbH does not assume responsibility for any conclusions and generalizations taken in conjunction with other specimens or samples of the type of the item presented to tests.

Also we refer on special conditions which the applicant should fulfill according §2.927 to §2.948, special focus regarding modification of the equipment and availability of sample equipment for market surveillance tests.

The presented Equipment Under Test (in this report, hereinafter referred as EUT) integrates a Bluetooth® LE transmitter.

Following test cases have been performed to show compliance with valid standards as mentioned in table below:

1.1. Tests measurement overview according of US CFR Title 47, Subpart 15C and Canada RSS-Standards:

| Test cases | Port | References & Limits | | | EUT set-up | EUT operating mode | Result |
|---|--|-----------------------------------|--|--|------------|--------------------|----------------------|
| | | FCC Standard | RSS Section | Test Limit | | | |
| TX-Mode | | | | | | | |
| Timing of transmitter (pulsed operation) | Antenna Terminal or enclosure | §15.35 | RSS-Gen, Issue 5 | -- | -- | -- | -- |
| 6 dB bandwidth | Antenna terminal (conducted) | §15.247(a)(2) | RSS-247, Chapter 5.2(a) RSS-Gen Issue 5: Chapter 4.6.2 | ≥ 500 kHz for DTS systems | 1 | 1 | passed |
| 99% occupied bandwidth | Antenna terminal (conducted) | 2.1049(h) | RSS-Gen Issue 5: Chapter 6.6 | 99% Power bandwidth | 1 | 1 | for Information only |
| Transmitter Peak output power | Antenna terminal (conducted) | §15.247(b)(3) | RSS-247, Chapter 5.4(d) | 1 Watt Peak | 1 | 1 | passed |
| Transmitter Peak output power radiated | Enclosure + Inter-connecting cables (radiated) | §15.247(b)(4) | RSS-247, Chapter 5.4(d) | < 4 Watt (EIRP) for antenna with directional gain less 6dBi | -- | -- | Not tested |
| Out-Of-Band RF- emissions Band-Edge emissions | Antenna terminal (conducted) | §15.247 (d) | RSS-247, Chapter 5.5 | 20 dBc | 1 | 1 | passed |
| Power spectral density | Antenna terminal (conducted) | §15.247(e) | RSS-247, Chapter 5.2(b) | 8dBm in any 3 kHz band | 1 | 1 | passed |
| General field strength emissions + restricted bands | Enclosure + Inter-connecting cables (radiated) | §15.247 (d) §15.205 §15.209 | RSS-247 Issue 2, Chapter 3.3 RSS-Gen: Issue 5: §8.9 Table 5+6+7 | Emissions in restricted bands must meet the general field-strength radiated limits | 2 | 2 | passed |

| | | | | | | | |
|---------------------------------------|--|---------------------------------|--|---|----|----|------------------------------|
| AC-Power Lines Conducted Emissions | AC-Power lines | §15.207 | RSS-Gen, Issue 5: Chapter 8.8, Table 3 | FCC §15.107 class B limits §15.207 limits ISED: Table 3, Chapter 8.8 | -- | -- | N/A *1) |
| RX Mode | | | | | | | |
| RECEIVER Radiated emissions | Enclosure + Inter-connecting cables (radiated) | RSS-Gen, Issue 5: Chapter 7.1.2 | ISED-limits: Table 2 | -- | -- | -- | See separate test report *2) |

*1) The tested device is a Car equipment powered by 12V battery.

*2) See test report **CETECOM_TR19-1-0103601T08a**

| RF-Exposure Evaluation (separation distance user to RF-radiating element greater 20cm) | | | | | | | |
|---|--|----------------------------------|--------------------|---|------------|--------------------|--------------------------------------|
| Test cases | Port | References & Limits | | | EUT set-up | EUT operating mode | Result |
| | | FCC Standard | RSS Section | Test Limit | | | |
| Radio frequency radiation exposure requirements | Cabinet + Inter-connecting cables (radiated) | §1.1310(b) §2.1091 §2.1093 | RSS-102 Issue 5 | SAR-Limits FCC: 1.1310(b) ISED: Table 3 | -- | -- | Not applicable *3) |
| | | | | RF-Field Strength Limits: FCC: “general population/ uncontrolled” environment Table 1 ISED: Table 4 | -- | -- | See separate test report/ evaluation |

*3) see separate document **FCC_MPE_short_report_19-1-0103601T09a** and **ISED_RF_exposure_Exemption_Letter_19-1-0103601T09b**

1.2. Attestation:

I declare that all measurements were performed by me or under my supervision and that all measurements have been performed and are correct to my best knowledge and belief to Industry Canada standards. All requirements as shown in above table are met in accordance with enumerated standards.

The current version of the Test Report CETECOM_TR19-1-0130601T07a-C1 replaces the Test Report CETECOM_TR19-1-0130601T07a dated 2019-11-07. The replaced test report is herewith invalid.

.....
Dipl.-Ing. Ch. Lorenz
Responsible for test section

.....
M.Sc. P. Marzotko
Responsible for test report

2. Administrative Data

2.1. Identification of the testing laboratory

| | |
|-------------------------------------|--|
| Company name: | CETECOM GmbH |
| Address: | Im Teelbruch 116 45219 Essen - Kettwig Germany |
| Responsible for testing laboratory: | Volker Wittmann |
| Deputy: | Dipl.-Ing. Niels Jeß |

2.2. Test location

2.2.1. Test laboratory "CTC"

| | |
|---------------|---|
| Company name: | see chapter 2.1. Identification of the testing laboratory |
|---------------|---|

2.3. Organizational items

| | |
|------------------------------|-------------------------|
| Responsible for test report: | B.Sc. M. Ahmed |
| Project leader: | M.Sc. P. Marzotko |
| Receipt of EUT: | 2019-08-13 |
| Date(s) of test: | 2019-08-20 – 2019-09-30 |
| Date of report: | 2019-11-27 |
| Version of template: | 13.02 |

2.4. Applicant's details

| | |
|-------------------|--|
| Applicant's name: | Continental Advanced Antenna GmbH |
| Address: | Römerring 1 31137 Hildesheim Germany |
| Contact person: | Mr. Timo Wetteborn |

2.5. Manufacturer's details

| | |
|----------------------|--------------------------------|
| Manufacturer's name: | please see Applicant's details |
| Address: | please see Applicant's details |

3. Equipment under test (EUT)

3.1. TECHNICAL DATA OF MAIN EUT DECLARED BY

| | | | |
|--|---|--|--------------------------------------|
| Model Nr. | TRANSCVRP02 | | |
| Type | BT-Transceiver | | |
| FCC ID | 2ACC7TRANSCVRP02 | | |
| ISED Certification Number | 11980A-TRANSCVRP02 | | |
| Frequency range (US/Canada -bands) | <input checked="" type="checkbox"/> 2402 MHz (Channel 1 = 01) to 2480 MHz (Channel 39) for 1MHz BW | | |
| Type of modulation | GFSK | | |
| Number of channels (USA/Canada -bands) | 40 (3 advertising channels (1/20/39), 37 channels are in hopping mode (0 to 39 with nominal channel frequency = 2402MHz + 2*k) with k: 0 to 39 | | |
| Antenna Type | <input type="checkbox"/> Integrated <input type="checkbox"/> External, no RF- connector <input checked="" type="checkbox"/> External, separate RF-connector | | |
| Antenna Gain | Max. 4 dBi gain according applicants information in 2.4 GHz band | | |
| Directional Gain | 7.01 dBi | | |
| MAX Field strength (radiated): | 93.473 dB μ V/m@3m distance | | |
| Occupied Bandwidth | 1.025 MHz | | |
| 6dB Emission Bandwidth | 701.298 kHz | | |
| Power supply | <input checked="" type="checkbox"/> 13.5 V DC | | |
| Special EMI components | -- | | |
| EUT sample type | <input type="checkbox"/> Production | <input checked="" type="checkbox"/> Pre-Production | <input type="checkbox"/> Engineering |
| FCC label attached | <input type="checkbox"/> yes | <input checked="" type="checkbox"/> no | |
| Ised Certification number Attached | <input type="checkbox"/> yes | <input checked="" type="checkbox"/> no | |

Remark: please refer to document System description "TRANSCVRP01_final_V6".

3.2. EUT: Type, S/N etc. and short descriptions used in this test report

| Short description*) | EUT | Type | S/N serial number | HW hardware status | SW software status |
|---------------------|-------------|----------------|-------------------|--------------------|-----------------------|
| EUT A S07 | TRANSCVRP02 | BT-Transceiver | 000034 | 01S | BT-Stack: 01.03.05 |
| EUT B S06 | TRANSCVRP02 | BT-Transceiver | 000045 | 01S | BT-Stack: 01.03.05 |

*) EUT short description is used to simplify the identification of the EUT in this test report.

3.3. Auxiliary Equipment (AE): Type, S/N etc. and short descriptions

| AE short description *) | Auxiliary Equipment | Type | S/N serial number | HW hardware status | SW software status |
|-------------------------|---|------------------------|--------------------|--------------------|--------------------|
| AE 1 | Measurement plate with 2 Bluetooth Slot patch Antenna | 9Y0 051 506 A | 002430 | 13611914 | -- |
| | | 9Y0 051 506 A | 002416 | | |
| AE 2 | Power Supply Cable | -- | -- | -- | - |
| AE 3 | CAN transceiver | Peak CAN-USB Interface | IPEH-002022-214006 | -- | -- |
| AE 4 | Dell Laptop CTC462012 | Latitude E6420 | JS5WDS1 | Intel Core i5 | Windows 7 |

*) AE short description is used to simplify the identification of the auxiliary equipment in this test report.

3.4. EUT set-ups

| EUT set-up no. *) | Combination of EUT and AE | Remarks |
|-------------------|--|---------------------------------|
| set. 1 | EUTA + AE2 + AE3 + AE4 | Used for conducted measurements |
| set. 2 | EUTB + AE1 + AE2 + AE3** + AE4** + Cable | Used for radiated measurements |

*) EUT set-up no. is used to simplify the identification of the EUT set-up in this test report.

***) AE 3 and AE 6 were placed outside the chamber during tests

3.5. EUT operating modes

| EUT operating mode no. *) | Description of operating modes | Additional information |
|---------------------------|--------------------------------|--|
| op. 1 | Continuous TX-Mode | The EUT was put to continuous transmissions mode with help of a special software named ' UDS_communication '. |

*) EUT operating mode no. is used to simplify the test report.

3.6. Test Settings

| Modulation | Packettype | Frame length | TX-Power |
|------------|------------|--------------|----------|
| GFSK | PRBS9 | 32 | 31 |

3.7. Test Software

| SW name | Version | Date | Storage |
|-------------------|---------|------|--------------|
| UDS_communication | r60 | - | Saved on AE6 |

Remarks: Settings were set according to customer specification document "TRANSCVRP01_final_V6".

3.8. Configuration of cables used for testing

| No. of cables | Item | Type | S/N serial number | HW hardware status | Cable length |
|---------------|------------------------|---------------------|-------------------|--------------------|--------------|
| 2 | Quaestum Antenna Cable | Fakra Antenna cable | RTK031 | - | 2.5m |
| 1 | Power Supply Cable | - | - | - | 2m |

3.9. Worst Case Selection

Maximum conducted output power and **Power Spectral Density** were tested on both connectors at the EUT

- ➔ PORT1(see pictures in annex 3) is worst case connector.
- ➔ All other conducted Tests were performed on PORT1

4. Description of test system set-up's

4.1. Test system set-up for conducted measurements on antenna port

Conducted RF-Setup 1 (BT1 Set-up)

General description:

The EUT's RF-signal is coupled out by a suitable antenna coupling connector (1). The signal is first attenuated (2) then connected to the power meter (3) for conducted power measurements. The specific attenuation loss is determined prior to the measurement within a set-up attenuation measurement. These are then taken into account by correcting the measurement readings.

Schematic:

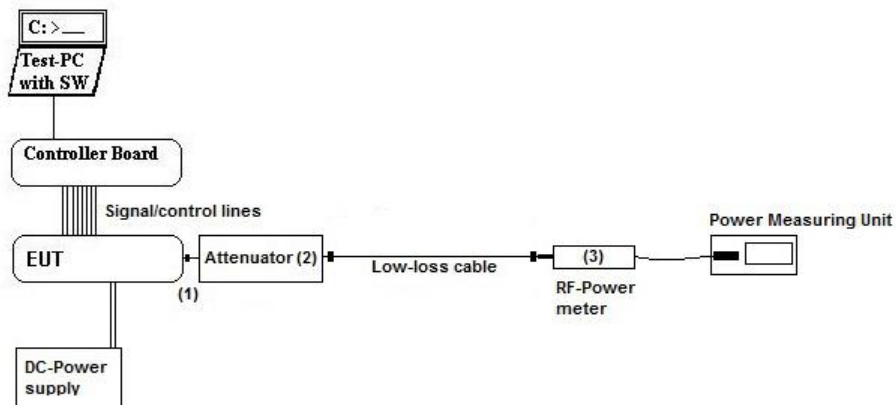

Testing method:

ANSI C63.10:2013, KDB 558074 D01 DTS Meas. Guidance v05r02

Used Equipment

| Passive Elements | Test Equipment | Remark: |
|--|---|---|
| <input checked="" type="checkbox"/> 20 dB Attenuator | <input checked="" type="checkbox"/> Power Meter TS8997 Test System | See List of equipment under each test case and chapter 8 for calibration info |
| <input checked="" type="checkbox"/> Low loss RF-cables | <input checked="" type="checkbox"/> DC-Power Supply | |

Measurement uncertainty

See chapter 8

4.2. Test system set-up for radiated magnetic field measurements below 30 MHz

Specification: ANSI C63.4-2014 §5.3, §8.2.1, §8.3.1.1+§8.3.2.1 , ANSI C63.10-2013 chapter 6.4 (§6.4.4.2)

General Description: Evaluating the radiated field emissions are done first by an exploratory emission measurement and a final measurement for most critical frequencies determined.

The loop antenna was placed at 1 m height above ground plane and 3 m measurement distance from set-up for investigations. Because of reduced measurement distance, correction data were applied, as stated in chapter “General Limit - Radiated field strength emissions below 30 MHz“. The tests are performed in the semi anechoic room recognized by the regulatory commission.

Schematic:

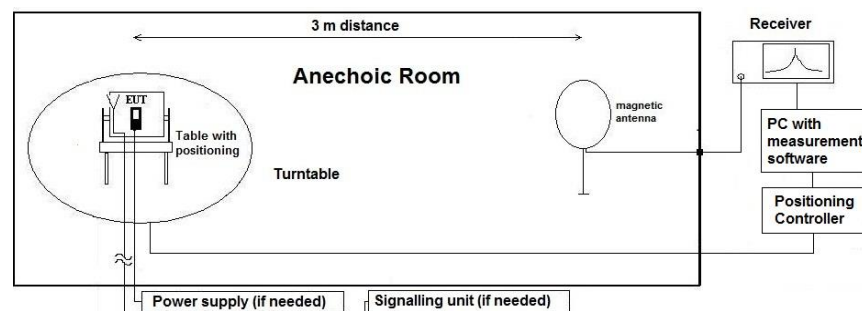

Testing method:

Exploratory, preliminary measurement

The EUT and its associated accessories are placed on a non-conductive position manipulator (tipping device) of 0.8 m height which is placed on the turntable. By rotating the turntable (step 90°, range 0° to 360°) and the EUT itself either on 3-orthogonal axis (portable equipment) or 2-orthogonal axis (defined operational position of EUT), the emission spectrum was recorded. The loop antenna was moved at least to 2-perpendicular axes (antenna vector in direction of EUT and parallel to EUT) in order to maximize the emissions. The results are documented in a diagram. Critical frequencies (low margin to limit) are saved within a data reduction table for further investigations. If various operating modes are supported, further investigations are made to find the worst-case. Also the interconnection cables and equipment position were varied in order to maximize the emissions.

Final measurement on critical frequencies

Based on the exploratory measurements, the most critical frequencies are re-measured by maintaining the EUT's worst-case operation mode, cable position, etc.

First a frequency zoom around the critical frequency is done to locate the frequency more precisely. After this step, for all identified critical frequencies, the maximum peak was determined.

Following parameters were varied: the turntable angle continuously in the range 0 to 360 degree, the EUT itself either over 3-orthogonal axis (not defined usage position) or 2-orthogonal axis (defined usage position).

On the determined worst-case position, a final measurement with necessary bandwidth and detector according standard has been carried out.

Formula:

$$E_C = E_R + AF + C_L + D_F - G_A$$

$$M = L_T - E_C$$

AF = Antenna factor

C_L = Cable loss

D_F = Distance correction factor

E_C = Electrical field – corrected value

E_R = Receiver reading

G_A = Gain of pre-amplifier (if used)

L_T = Limit

M = Margin

All units are dB-units, positive margin means value is below limit.

Distance correction:

Reference for applied correction (extrapolating) factors due to reduced measurement distance:

ANSI C63.10:2013, §6.4.4.2 - Equations (2) + (3) + (4)

4.3. Test system set-up for radiated electric field measurement 30 MHz to 1 GHz

Specification: ANSI C63.4-2014 chapter 8.2.3, ANSI C63.10-2013 chapter 6.5

General Description: Evaluating the field emissions have to be done first by an exploratory emissions measurement and a final measurement for most critical frequencies. The tests are performed in a NSA-compliant semi anechoic room (SAR) recognized by the regulatory commissions.

Schematic:

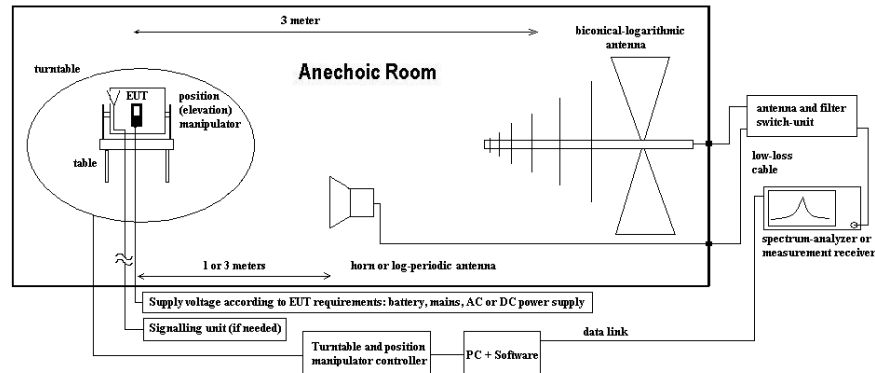

Testing method:

Exploratory, preliminary measurements

The EUT and its associated accessories are placed on a non-conductive position manipulator (tipping device) of 0.8 m height which is placed on the turntable. By rotating the turntable (range 0° to 360°, step 90°) and the EUT itself either on 3-orthogonal axis (portable equipment) or 2-orthogonal axis (defined operational position of EUT) the emission spectrum and its characteristics was recorded with an EMI-receiver, broadband antenna and software.

Measurement antenna: horizontal and vertical, heights: 1,0 m and 1,82 m as worst-case determined by an exploratory emission measurements. The results are documented in a diagram. Critical frequencies (low margin to limit) are saved within a table for further investigations. If various operating modes are supported, further investigations are made to find the worst-case of them. Also the interconnection cables and equipment position were varied in order to maximize the emissions.

Final measurement on critical frequencies

Based on the exploratory measurements, the most critical frequencies are re-measured by maintaining the EUT's worst-case operation mode, cable position, etc. either on 10m OATS or 3m semi-anechoic room.

First a frequency zoom around the critical frequency is done to locate the frequency more precisely. After this step, for all identified critical frequencies, the maximum peak was determined.

Following parameters were varied: the turntable angle continuously in the range 0 to 360 degree, the EUT itself either over 3-orthogonal axis (not defined usage position) or 2-orthogonal axis (defined usage position). The measurement antenna height between 1 m and 4 m.

On the determined worst-case position, a final measurement with necessary bandwidth and detector according standard has been carried out.

Formula:

$$E_C = E_R + AF + C_L + D_F - G_A \quad (1)$$

$$M = L_T - E_C \quad (2)$$

- AF = Antenna factor
- C_L = Cable loss
- D_F = Distance correction factor (if used)
- E_C = Electrical field – corrected value
- E_R = Receiver reading
- G_A = Gain of pre-amplifier (if used)
- L_T = Limit
- M = Margin

All units are dB-units, positive margin means value is below limit.

4.4. Test system set-up for radiated electric field measurement above 1 GHz

Specification: ANSI C63.4-2014 chapter 8.3, ANSI C63.10-2013 chapter 6.6.3.3 & 6.6.4

General Description: Evaluating the emissions have to be done first by an exploratory emissions measurement and a final measurement for most critical frequencies. The tests are performed in a CISPR 16-1-4:2010 compliant fully anechoic room (FAR) recognized by the regulatory commission. The measurement distance was set to 3 meter for frequencies up to 18 GHz and 2 meter above 18 GHz. A logarithmic periodic antenna is used for the frequency range 30 MHz to 1 GHz. Horn antennas are used for frequency range 1 GHz to 40 GHz. The EUT is aligned within 3 dB beam width of the measurement antenna with three orthogonal axis measurements on the EUT.

Schematic:

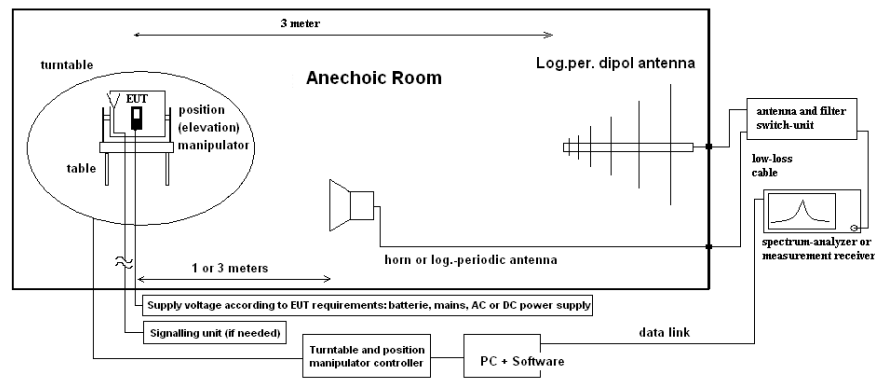

Testing method:

Exploratory, preliminary measurements

The EUT and its associated accessories are placed on a non-conductive position manipulator (tipping device) of 1.55 m height which is placed on the turntable. By rotating the turntable (range 0° to 360°, step 15°) and the EUT itself either on 3-orthogonal axis (portable equipment) or 2-orthogonal axis (defined operational position of EUT) the emission spectrum and its characteristics was recorded with an EMI-receiver, broadband antenna and software. The measurements are performed in horizontal and vertical polarization of the measurement antennas. The results are documented in a diagram. Critical frequencies (low margin to limit) are saved within a table for further investigations. If various operating modes are supported, further investigations are made to find the worst-case of them. Also the interconnection cables and equipment position were varied in order to maximize the emissions.

Final measurement on critical frequencies

Based on the exploratory measurements, the most critical frequencies are re-measured by maintaining the EUT's worst-case operation mode, cable position, etc.

First a frequency zoom around the critical frequency is done to locate the frequency more precisely. After this step, for all identified critical frequencies, the maximum peak was determined. Following parameters were varied: the turntable angle continuously in the range 0 to 360 degree, the EUT itself over 3-orthogonal axis and the height for EUT with large dimensions.

On the determined worst-case position, a final measurement with necessary bandwidth and detector according standard has been carried out. On the determined worst-case position, a final measurement with necessary bandwidth and detector according standard has been carried out.

Formula:

$$E_C = E_R + AF + C_L + D_F - G_A \quad (1)$$

$$M = L_T - E_C \quad (2)$$

E_C = Electrical field – corrected value

E_R = Receiver reading

M = Margin

L_T = Limit

AF = Antenna factor

C_L = Cable loss

D_F = Distance correction factor (if used)

G_A = Gain of pre-amplifier (if used)

All units are dB-units, positive margin means value is below limit.

5. Measurements

5.1. Duty-Cycle

5.1.1. Test location and equipment (for reference numbers please see chapter 'List of test equipment')

| Ambient Climatic conditions | | Temperature: (22±2)°C | | | Rel. humidity: (45±15)% | |
|-----------------------------|---|--|---|--|--|---|
| test site | <input type="checkbox"/> 441 EMI SAR | <input type="checkbox"/> 348 EMI cond. | <input type="checkbox"/> 443 EMI FAR | <input checked="" type="checkbox"/> 347 Radio.lab. | <input type="checkbox"/> 337 OATS | <input type="checkbox"/> |
| equipment | <input type="checkbox"/> 331 HC 4055 | <input type="checkbox"/> | <input type="checkbox"/> | <input type="checkbox"/> | <input type="checkbox"/> | <input type="checkbox"/> |
| spectr. analys. | <input checked="" type="checkbox"/> 683 FSU26 | <input type="checkbox"/> 120 FSEM | <input type="checkbox"/> 264 FSEK | <input type="checkbox"/> | <input type="checkbox"/> | <input type="checkbox"/> |
| power meter | <input type="checkbox"/> 262 NRV-S | <input type="checkbox"/> 266 NRV-Z31 | <input type="checkbox"/> 265 NRV-Z33 | <input type="checkbox"/> 261 NRV-Z55 | <input type="checkbox"/> 356 NRV-Z1 | <input type="checkbox"/> |
| multimeter | <input type="checkbox"/> 341 Fluke 112 | <input type="checkbox"/> | <input type="checkbox"/> | <input type="checkbox"/> | <input type="checkbox"/> | <input type="checkbox"/> |
| DC power | <input type="checkbox"/> 086 LNG50-10 | <input type="checkbox"/> 087 EA3013 | <input type="checkbox"/> 354 NGPE 40 | <input type="checkbox"/> 349 car battery | <input type="checkbox"/> 350 Car battery | <input checked="" type="checkbox"/> 463 HP3245A |
| SupplyVoltage | <input checked="" type="checkbox"/> 12V DC | | | | | |
| line voltage | <input type="checkbox"/> 230 V 50 Hz via public mains | | <input type="checkbox"/> 060 120 V 60 Hz via PAS 5000 | | | |
| Multimeter | <input checked="" type="checkbox"/> 341 Fluke | | | | | |
| otherwise | <input checked="" type="checkbox"/> 530 Attenuator 10dB | <input checked="" type="checkbox"/> K4 Cable | | | | |

Method of measurement: conducted
 radiated

A special firmware program is used for test purposes. In opposite to normal operating mode a higher duty-cycle is set in order to facilitate the measurements. This is maximized at the extent possible.

The necessary duty-cycle correction factor is determined on nominal conditions on one channel in each operable frequency-band. It is assumed that no noticeable changes occur when tested on other channels or climatic conditions.

Results:

| Set-up No.: 1 Op. Mode: 1 | Marker 1 [BTS ON'] | Marker 2 [BTS ON'] | TX on | TX off | Converted to DC | 10log(1/DC) |
|------------------------------|-----------------------|-----------------------|-----------|-----------|--------------------|----------------|
| | us | us | us | us | | |
| BT-LE GFSK | | | | | | |
| 1MBit | 352.003205 | 624.759615 | 352.00321 | 272.75641 | 0.56342 | 2.49166 |

Remark: used for field strength measurements correction, where average results apply.

Calculated with following formulas:

| | | |
|--|------------------------|---|
| Duty cycle calculations: $x = \frac{TX_{ON}}{TX_{ON} + TX_{OFF}}$ | Duty cycle factor: DC= | Regarding power: $10 * \log\left(\frac{1}{x}\right)$ dB Regarding field strength: $20 * \log\left(\frac{1}{x}\right)$ dB |
|--|------------------------|---|

- The results were corrected in order to evaluate for worst-case result each time when average values are necessary for example radiated emissions based on average emissions.
- No correction necessary: Duty-Cycle > 98%

5.2. RF-Parameter - 6 dB Bandwidth and 99% occupied bandwidth

5.2.1. Test location and equipment (for reference numbers please see chapter 'List of test equipment')

| | | | |
|-----------------|--|---|--|
| test location | <input checked="" type="checkbox"/> CETECOM Essen (Chapter. 2.2.1) | <input type="checkbox"/> 443 System CTC-FAR-EMI- | <input type="checkbox"/> Please see Chapter. 2.2.3 |
| test site | <input type="checkbox"/> 441 EMI SAR | <input type="checkbox"/> 487 SAR NSA | <input checked="" type="checkbox"/> 347 Radio.lab. |
| receiver | <input type="checkbox"/> 377 ESCS30 | <input type="checkbox"/> 001 ESS | <input type="checkbox"/> 489 ESU 40 |
| spectr. analys. | <input type="checkbox"/> 584 FSU | <input type="checkbox"/> 120 FSEM | <input type="checkbox"/> 264 FSEK |
| antenna | <input type="checkbox"/> 574 BTA-L | <input type="checkbox"/> 133 EMCO3115 | <input type="checkbox"/> 302 BBHA9170 |
| signaling | <input type="checkbox"/> 392 MT8820A | <input type="checkbox"/> 436 CMU | <input type="checkbox"/> 547 CMU |
| otherwise | <input type="checkbox"/> 266 NRV-Z31 | <input type="checkbox"/> 600 NRVD | <input type="checkbox"/> 110 USB LWL |
| multimeter | <input checked="" type="checkbox"/> 341 Fluke 112 | | |
| DC power | <input type="checkbox"/> 456 EA 3013A | <input checked="" type="checkbox"/> 463 HP3245A | <input type="checkbox"/> 459 EA 2032-50 |
| otherwise | <input type="checkbox"/> 331 HC 4055 | <input type="checkbox"/> 248 6 dB Attenuator | <input type="checkbox"/> 529 Power divider |
| | <input type="checkbox"/> 513 20dB Attenuator | | <input type="checkbox"/> - cable OTA20 |
| line voltage | <input type="checkbox"/> 230 V 50 Hz via public mains | <input type="checkbox"/> 060 110 V 60 Hz via PAS 5000 | <input checked="" type="checkbox"/> 13.5 V DC |

5.2.2. References of occupied and emission bandwidth

§15.247(a)(2), RSS-247: Issue 2, Chapter 5.2(a); RSS-Gen Issue 5: Chapter 6.7

(2) DSSS Systems using digital modulation techniques may operate in the 902-928 MHz, 2400-2483.5 MHz, and 5725-5850 MHz bands. The minimum 6 dB bandwidth shall be at least 500 kHz.

5.2.3. Test condition and measurement test set-up

| | | | |
|---------------------------------------|--|--|--|
| Signal link to test system (if used): | <input type="checkbox"/> air link | <input type="checkbox"/> cable connection | <input checked="" type="checkbox"/> none |
| EUT-grounding | <input checked="" type="checkbox"/> none | <input type="checkbox"/> with power supply | <input type="checkbox"/> additional connection |
| Equipment set up | <input checked="" type="checkbox"/> table top | | <input type="checkbox"/> floor standing |
| Climatic conditions | Temperature: (22±3°C) | | Rel. humidity: (40±20)% |
| General measurement procedures | Please see chapter "Test system set-up for conducted RF-measurement at antenna Port" (W2 Set-up) | | |

5.2.4. EUT Settings:

The EUT was instructed to transmit with maximum power (if adjustable) according applicants declared and applicable settings.

Different modulation characteristics have been checked, e.g. data rates which EUT can operate if applicable.

5.2.5. Measurement method:

Three carrier frequencies (low/middle/high) were used for showing the compliance with this requirement. A delta Marker method was set to measure the bandwidth compared to the highest In-Band power. The operating modes have been varied (e.g. data rate, modulation scheme, etc.). If applicable the hopping-mode is switched off.

Also the **99% emission bandwidth** was measured. Two markers are placed on frequency points such that left to lower f-marker and right to higher f-marker only 1% of the TX-power is contained. Between the markers, 99% of the power is laying. The RBW value is readjusted and the measurement repeated until the RBW/EBW ratio is around 1%.

5.2.6. Spectrum-Analyzer settings:

| | |
|----------------------------|--|
| Span | Set as to fully display the emissions + 30% |
| Scale y display | approximate 30dB below the maximum PEAK level |
| Resolution Bandwidth (RBW) | <input type="checkbox"/> ANSI 63.2013 Set to initial value approx 1% to 5% of the emission bandwidth, re-adjust and proof that RBW/EBW is between 1% and 5% <input checked="" type="checkbox"/> KDB558074v05r02 |
| Video Bandwidth (VBW) | Minimum 3 times the resolution bandwidth |
| Sweep time | Auto -coupled |
| Detector | Peak detector |
| Sweep mode | Repetitive Mode, MAX-HOLD, trace stabilization |

5.2.7. Results:

For graphical results pls. see annex 1 to this test report.

6dB BANDWIDTH:

| Set-up no.: 1 Op. Mode: 1/2/3 | 6dB BANDWIDTH [kHz] | | |
|---|--------------------------------|-----------------------------------|---------------------------------|
| T _{NOM} = 21°C V _{NOM} | Low channel = 37 (2402 MHz) | Middle channel = 20 (2442 MHz) | High channel = 39 (2480 MHz) |
| Measured Level | 0.701298 | 0.688311 | 0.688311 |

Remark: For graphical results pls. see annex 1 to this test report.

99% OCCUPIED BANDWIDTH:

| Set-up no.: 1 Op. Mode: 1/2/3 | 99% Bandwidth [MHz] | | |
|---|--------------------------------|-----------------------------------|---------------------------------|
| T _{NOM} = 21°C V _{NOM} | Low channel = 37 (2402 MHz) | Middle channel = 20 (2442 MHz) | High channel = 39 (2480 MHz) |
| Measured Level | 1.025 | 1.025 | 1.025 |

Remark: For graphical results pls. see annex 1 to this test report.

VERDICT: DTS system requirements for 6dB-bandwidth according §15.247 (BW > 500kHz) passed

5.3. Maximum peak conducted output power

5.3.1. Test location and equipment (for reference numbers please see chapter 'List of test equipment')

| | | | | | | |
|-----------------|--|--|---|---|--|--|
| test location | <input checked="" type="checkbox"/> CETECOM Essen (Chapter. 2.2.1) | <input type="checkbox"/> 443 System CTC-FAR-EMI- | <input type="checkbox"/> Please see Chapter. 2.2.3 | | | |
| test site | <input type="checkbox"/> 441 EMI SAR | <input type="checkbox"/> 487 SAR NSA | <input checked="" type="checkbox"/> 347 Radio.lab. | | <input type="checkbox"/> | <input type="checkbox"/> |
| receiver | <input type="checkbox"/> 377 ESCS30 | <input type="checkbox"/> 001 ESS | <input type="checkbox"/> 489 ESU 40 | <input type="checkbox"/> | <input type="checkbox"/> | <input type="checkbox"/> |
| spectr. analys. | <input type="checkbox"/> 584 FSU | <input type="checkbox"/> 120 FSEM | <input type="checkbox"/> 264 FSEK | <input type="checkbox"/> 489 ESU 40 | <input type="checkbox"/> 683 FSU26 | <input type="checkbox"/> |
| antenna | <input type="checkbox"/> 574 BTA-L | <input type="checkbox"/> 133 EMCO3115 | <input type="checkbox"/> 302 BBHA9170 | <input type="checkbox"/> 289 CBL 6141 | <input type="checkbox"/> 030 HFH-Z2 | <input type="checkbox"/> 477 GPS |
| signaling | <input type="checkbox"/> 392 MT8820A | <input type="checkbox"/> 436 CMU | <input type="checkbox"/> 547 CMU | | | |
| otherwise | <input type="checkbox"/> 266 NRV-Z31 | <input type="checkbox"/> 600 NRVD | <input type="checkbox"/> 110 USB LWL | <input type="checkbox"/> 482 Filter Matrix | <input type="checkbox"/> 378 RadiSense | <input checked="" type="checkbox"/> 693 TS8997 |
| multimeter | <input checked="" type="checkbox"/> 341 Fluke 112 | | | | | |
| DC power | <input type="checkbox"/> 456 EA 3013A | <input checked="" type="checkbox"/> 463 HP3245A | <input type="checkbox"/> 459 EA 2032-50 | <input type="checkbox"/> 268 EA- 3050 | <input type="checkbox"/> 494 AG6632A | <input type="checkbox"/> 498 NGPE 40 |
| otherwise | <input type="checkbox"/> 331 HC 4055 | <input type="checkbox"/> 248 6 dB Attenuator | <input type="checkbox"/> 529 Power divider | <input type="checkbox"/> - cable OTA20 | | |
| | <input type="checkbox"/> 513 20dB Attenuator | | <input type="checkbox"/> K 4 Cable kit | | | |
| line voltage | <input type="checkbox"/> 230 V 50 Hz via public mains | | <input type="checkbox"/> 060 110 V 60 Hz via PAS 5000 | <input checked="" type="checkbox"/> 13.5 V DC | | |

5.3.2. Reference

| | |
|---------------|---|
| FCC | <input checked="" type="checkbox"/> §15.247(b) (3) + KDB 558074 D01 DTS Meas Guidance v05r02 |
| ISED | <input checked="" type="checkbox"/> RSS-247, Issue 2 Chapter 5.4(d) |
| ANSI | <input checked="" type="checkbox"/> ANSI 63.10:2013 |
| KDB Guidance | <input checked="" type="checkbox"/> 662911 D01 V02r01 (MIMO, Smart-antenna) |
| Specification | <i>For systems using digital modulation in the 902-928 MHz, 2400-2483.5 MHz, and 5725-5850 MHz bands: 1 Watt. As an alternative to a peak power measurement, compliance with the one Watt limit can be based on a measurement of the maximum conducted output power. Maximum Conducted Output Power is defined as the total transmit power delivered to all antennas and antenna elements averaged across all symbols in the signaling alphabet when the transmitter is operating at its maximum power control level. Power must be summed across all antennas and antenna elements. The average must not include any time intervals during which the transmitter is off or is transmitting at a reduced power level. If multiple modes of operation are possible (e.g., alternative modulation methods), the maximum conducted output power is the highest total transmit power occurring in any mode.</i> |

5.3.3. EUT settings:

The EUT was instructed to send with maximum power (if adjustable) according applicants instructions. Different modulation characteristics have been checked, e.g. data rates which EUT can operate.

5.3.4. Test condition and measurement test set-up

| | | | |
|---------------------------------------|--|--|---|
| Signal link to test system (if used): | <input type="checkbox"/> air link | <input type="checkbox"/> cable connection | <input checked="" type="checkbox"/> none |
| EUT-grounding | <input checked="" type="checkbox"/> none | <input type="checkbox"/> with power supply | <input type="checkbox"/> additional connection. |
| Equipment set up | <input checked="" type="checkbox"/> table top 1.5m height | | |
| Climatic conditions | Temperature: (22±3°C) | | Rel. humidity: (40±20)% |
| General measurement procedures | Please see chapter "Test system set-up for conducted RF-measurement at antenna Port" (W1 Set-up) | | |

5.3.5. Measurement method and analyzer settings:

The measurement was performed in non-hopping transmission mode with the carrier set to lowest/middle and highest channel. The power was also checked for different data rates, modulation scheme or packet types if applicable.

MEASUREMENT METHOD/ SPECTRUM-ANALYZER SETTINGS:

| | | |
|----------------------------------|--|---|
| Measurement Method ¹⁾ | §15.247(b) (3) Maximum Peak | 1.) <input checked="" type="checkbox"/> 9.1.1 Maximum peak conducted output power (RBW > 6dB-bandwidth of the signal) 2.) <input type="checkbox"/> 9.1.3. PKPM1 Peak reading power meter (broadband PK meter) |
| | §15.247(b) (3) Maximum Average | 3.) <input type="checkbox"/> AVGSA-1 / AVGSA-1 alternative (duty-cycle > 98%) 4.) <input type="checkbox"/> AVGSA-2 / AVGSA-2 alternative (duty-cycle < 98%, constant) 5.) <input type="checkbox"/> AVGSA-3 / AVGSA-3 alternative (duty-cycle < 98%, not constant) |
| Center Frequency | Nominal channel frequency | |
| Span | 30% higher then the EBW measured before | |
| Resolution Bandwidth (RBW) | 2MHz | |
| Video Bandwidth (VBW) | 10MHz | |
| Sweep time | coupled | |
| Detector | Peak, Max hold mode for method PK1/PK2 or RMS and trace average for method AVG1/AVG2 | |
| Sweep Mode | Repetitive mode, allow trace to stabilize | |
| Analyzer-Mode | <input checked="" type="checkbox"/> normal <input type="checkbox"/> activated channel integration method with limits set to the EBW of the signal | |

Remark 1: guidance 558074 D01 measurement DTS guidance v03r05

5.3.6. RESULTS

APPLICANT'S DECLARED ANTENNA CHARACTERISTICS:

- Applicant's Maximum declared antenna gain [isotropic]: **4 dBi**

For Directional Antenna Gain

| | |
|-----------------------------------|--|
| Directional Antenna Gain (dBi) | $G_T = G_{ANT} + 10 * \text{Log}(N_{ANT})$ |
|-----------------------------------|--|

Directional Antenna Gain = **7.01 dBi**

§15.247-Operation within the bands 902-928 MHz, 2400-2483.5 MHz, and 5725-5850 MHz.

Systems operating in the 2400-2483.5 MHz band that are used exclusively for fixed, point-to-point operations may employ transmitting antennas with directional gain greater than 6 dBi provided the maximum conducted output power of the intentional radiator is reduced by 1 dB for every 3 dB that the directional gain of the antenna exceeds 6 dBi.

- Conducted power reduction not necessary.
- Conducted power reduction necessary.

| Max. Peak power (conducted) [dBm] | | | |
|--------------------------------------|-------------------------------|-----------------------------------|---------------------------------|
| Set-up no: 1 Op-Mode: 1 | Low channel =01 (2402 MHz) | Middle channel = 20 (2442 MHz) | High channel = 39 (2480 MHz) |
| Measured Level on Port 1 | -4.8 | -4.2 | -4.8 |
| Measured Level on Port 2 | -5.2 | -4.8 | -5.1 |
| Combined level for Both Ports | -2.01 | -1.49 | -1.94 |
| Limit | 1 Watt (30dBm) Peak | | |

Remark: for plots see annex 1

5.3.6.1. VERDICT: Maximum value of -1.49 dBm Peak (0.71 mW) -> Passed

5.4. RF-Parameter - Power Spectral Density

5.4.1. Test location and equipment (for reference numbers please see chapter 'List of test equipment')

| | | | |
|-----------------|--|---|--|
| test location | <input checked="" type="checkbox"/> CETECOM Essen (Chapter. 2.2.1) | <input type="checkbox"/> 443 System CTC-FAR-EMI- | <input type="checkbox"/> Please see Chapter. 2.2.3 |
| test site | <input type="checkbox"/> 441 EMI SAR | <input type="checkbox"/> 487 SAR NSA | <input checked="" type="checkbox"/> 347 Radio.lab. |
| receiver | <input type="checkbox"/> 377 ESCS30 | <input type="checkbox"/> 001 ESS | <input type="checkbox"/> 489 ESU 40 |
| spectr. analys. | <input type="checkbox"/> 584 FSU | <input type="checkbox"/> 120 FSEM | <input type="checkbox"/> 264 FSEK |
| antenna | <input type="checkbox"/> 574 BTA-L | <input type="checkbox"/> 133 EMCO3115 | <input type="checkbox"/> 302 BBHA9170 |
| signaling | <input type="checkbox"/> 392 MT8820A | <input type="checkbox"/> 436 CMU | <input type="checkbox"/> 547 CMU |
| otherwise | <input type="checkbox"/> 266 NRV-Z31 | <input type="checkbox"/> 600 NRVD | <input type="checkbox"/> 110 USB LWL |
| multimeter | <input checked="" type="checkbox"/> 341 Fluke 112 | | |
| DC power | <input type="checkbox"/> 456 EA 3013A | <input checked="" type="checkbox"/> 463 HP3245A | <input type="checkbox"/> 459 EA 2032-50 |
| line voltage | <input type="checkbox"/> 230 V 50 Hz via public mains | <input type="checkbox"/> 060 110 V 60 Hz via PAS 5000 | <input checked="" type="checkbox"/> 13.5 V DC |

5.4.2. REFERENCES: §15.247(e), RSS-247, Issue 2: Chapter 5.2(b)

(e) For digitally modulated systems, the power spectral density conducted from the intentional radiator to the antenna shall not be greater than 8 dBm in any 3 kHz band during any time interval of continuous transmission. This power spectral density shall be determined in accordance with the provisions of paragraph (b) of this section. The same method of determining the conducted output power shall be used to determine the power spectral density.

5.4.3. TEST CONDITION AND MEASUREMENT TEST SET-UP

| | | | |
|---------------------------------------|--|--|--|
| Signal link to test system (if used): | <input type="checkbox"/> air link | <input type="checkbox"/> cable connection | <input checked="" type="checkbox"/> none |
| EUT-grounding | <input checked="" type="checkbox"/> none | <input type="checkbox"/> with power supply | <input type="checkbox"/> additional connection |
| Equipment set up | <input checked="" type="checkbox"/> table top | | <input type="checkbox"/> floor standing |
| Climatic conditions | Temperature: (22±3°C) | | Rel. humidity: (40±20)% |
| General measurement procedures | Please see chapter "Test system set-up for conducted RF-measurement at antenna Port" (W2 Set-up) | | |

5.4.4. EUT SETTINGS:

The EUT was instructed to send with maximum power (if adjustable) according applicants instructions. Different modulation characteristics have been checked, e.g. data rates which EUT can operate.

5.4.5. MEASUREMENT METHOD/ SPECTRUM-ANALYZER SETTINGS

| | | |
|--------------------------------|---|--|
| Measurement Method | <input type="checkbox"/> ANSI 63.10: 2013 | <input checked="" type="checkbox"/> PKPSD-Method |
| | | <input type="checkbox"/> AVGPSD Method |
| KDB Guidance | <input checked="" type="checkbox"/> guidance 558074 D01 measurement DTS guidance v05r02 | |
| | <input checked="" type="checkbox"/> 662911 D01 V02r01 (MIMO, Smart-antenna) | |
| Center Frequency | Nominal channel frequency | |
| Span | 5..30% higher than the EBW measured before | |
| Resolution Bandwidth (RBW) | <= 10 kHz - pls. see diagram | |
| Video Bandwidth (VBW) | >= 30 kHz - (at least 3 times RBW) pls. see diagram | |
| Sweep time | coupled | |
| Detector | Peak, Max hold mode for method PKPSD or RMS method AVGPSD | |
| Sweep Mode | Repetitive mode, allow trace to stabilize (PKPSD) or single (AVGPSD) | |
| Addition of correction factors | external measuring set-up path-loss | |

5.4.6. RESULTS

| Set-up No.: 1 Op. Mode: 1 V _{NOM} , T _{NOM} | POWER SPECTRAL DENSITY [dBm/3 kHz] | | |
|---|---------------------------------------|-----------------------------------|---------------------------------|
| | Low channel = 01 (2402 MHz) | Middle channel = 20 (2442 MHz) | High channel = 39 (2480 MHz) |
| Measured Level on Port 1 | -13.541 | -13.048 | -13.383 |
| Measured Level on Port 2 | -14.382 | -14.106 | -14.214 |
| Combined Level for both Ports | -10.93 | -10.53 | -10.77 |
| Limit | < 8dBm/3 kHz | | |

Remark: see diagrams for details on frequency in separate annex A1

5.4.7. VERDICT: PASSED

5.5. 20 dBc power specification

5.5.1. Test location and equipment (for reference numbers please see chapter 'List of test equipment')

| | | | |
|-----------------|--|---|--|
| test location | <input checked="" type="checkbox"/> CETECOM Essen (Chapter. 2.2.1) | <input type="checkbox"/> 443 System CTC-FAR-EMI- | <input type="checkbox"/> Please see Chapter. 2.2.3 |
| test site | <input type="checkbox"/> 441 EMI SAR | <input type="checkbox"/> 487 SAR NSA | <input checked="" type="checkbox"/> 347 Radio.lab. |
| receiver | <input type="checkbox"/> 377 ESCS30 | <input type="checkbox"/> 001 ESS | <input type="checkbox"/> 489 ESU 40 |
| spectr. analys. | <input type="checkbox"/> 584 FSU | <input type="checkbox"/> 120 FSEM | <input type="checkbox"/> 264 FSEK |
| antenna | <input type="checkbox"/> 574 BTA-L | <input type="checkbox"/> 133 EMCO3115 | <input type="checkbox"/> 302 BBHA9170 |
| signaling | <input type="checkbox"/> 392 MT8820A | <input type="checkbox"/> 436 CMU | <input type="checkbox"/> 547 CMU |
| otherwise | <input type="checkbox"/> 266 NRV-Z31 | <input type="checkbox"/> 600 NRVD | <input type="checkbox"/> 110 USB LWL |
| multimeter | <input checked="" type="checkbox"/> 341 Fluke 112 | | |
| DC power | <input type="checkbox"/> 456 EA 3013A | <input checked="" type="checkbox"/> 463 HP3245A | <input type="checkbox"/> 459 EA 2032-50 |
| otherwise | <input type="checkbox"/> 331 HC 4055 | <input type="checkbox"/> 248 6 dB Attenuator | <input type="checkbox"/> 529 Power divider |
| | <input type="checkbox"/> 513 20dB Attenuator | <input type="checkbox"/> K 4 Cable kit | <input type="checkbox"/> - cable OTA20 |
| line voltage | <input type="checkbox"/> 230 V 50 Hz via public mains | <input type="checkbox"/> 060 110 V 60 Hz via PAS 5000 | <input checked="" type="checkbox"/> 12 V DC |

5.5.2. Reference: §15.247, §15.205 / RSS-247: Issue 2, Chapter 5.5

(d) In any 100 kHz bandwidth outside the frequency band in which the spread spectrum or digitally modulated intentional radiator is operating, the radio frequency power that is produced by the intentional radiator shall be at least 20 dB below that in the 100 kHz bandwidth within the band that contains the highest level of the desired power, based on either an RF conducted or a radiated measurement, provided the transmitter demonstrates compliance with the peak conducted power limits.

5.5.3. Test condition and measurement test set-up

| | | | |
|--------------------------------------|---|---|---|
| Signal ink to test system (if used): | <input type="checkbox"/> air link | <input type="checkbox"/> cable connection | <input checked="" type="checkbox"/> none |
| EUT-grounding | <input checked="" type="checkbox"/> none | <input type="checkbox"/> with power supply | <input type="checkbox"/> additional connection. |
| Equipment set up | <input checked="" type="checkbox"/> table top 1.5m height | <input type="checkbox"/> floor standing | |
| Climatic conditions | Temperature: (22±3°C) | Rel. humidity: (40±20)% | |
| Spectrum-Analyzer settings | Scan frequency range: Scan-Mode Detector RBW/VBW Mode: Scan step Sweep-Time | <input type="checkbox"/> 1 – 18 GHz <input type="checkbox"/> 18 – 25 GHz <input type="checkbox"/> 18 – 40 GHz <input checked="" type="checkbox"/> other: see diagrams <input type="checkbox"/> 6 dB EMI-Receiver Mode <input checked="" type="checkbox"/> 3 dB Spectrum analyser Mode Peak and Average 100kHz/300kHz Repetitive-Scan, max-hold 40kHz Coupled – calibrated display if CW signal otherwise adapted to EUT's individual duty-cycle | |
| General measurement procedures | Please see chapter "Test system set-up for radiated electric field measurements above 1 GHz" for general measurements procedures in anechoic chamber. | | |

5.5.4. EUT settings

For FHHS-systems hopping mode was switched-off so fixed three different channels could be measured. The EUT was instructed to send with maximum power (if adjustable) and nominal modulation scheme according to applicants instructions.

5.5.5. Measurement method

According guidance 558074 D01 measurement DTS guidance V05r02: the frequency spectrum was investigated for conducted spurious emissions values lower than 20dB related to the reference RF-carrier peak power value. Three carrier frequencies (low/middle/high channel) were used for showing the compliance with this requirement. First a In-Band Reference level measurement of the carrier was performed. The video bandwidth (VBW) was chosen 3 times the resolution bandwidth (RBW). The frequency scan was up to 10 times the highest channel frequency within the operational mode. The spectrum-analyzer was set to MAX-PEAK Detector, MAX-Hold Mode, trace stabilization.

5.5.6. Table of Measurement results:

| Set-up No.: 1 Op. Mode: 1 | RF-Conducted test: 20 dBc spurious emissions | | | | | |
|------------------------------|---|-------------|--|-------------|--|-------------|
| Frequency Range | Low channel = 01 (2402 MHz) | | Middle channel = 20 (2442 MHz) | | High channel = 39 (2480 MHz) | |
| | Level Reference (In-Band) = -4.37 dBm Limit = -24.4 dB μ V /m | | Level Reference (In-Band) = -3.92 dBm Limit = -23.92 dBm | | Level Reference (In-Band) = -4.76 dBm Limit = -24.76 dBm | |
| | Frequency [MHz] | Value [dBc] | Frequency [MHz] | Value [dBc] | Frequency [MHz] | Value [dBc] |
| 150kHz to 30MHz | Peaks from set-up (AE-equipment) | > -38 | Peaks from set-up (AE-equipment) | > -38 | Peaks from set-up (AE-equipment) | > -38 |
| 30 MHz to 2.8 GHz | -- | > -38 | -- | > -38 | -- | > -38 |
| 2.8 to 26 GHz | -- | > -36 | -- | > -36 | -- | > -36 |

Remark: see diagrams in separate document A1

The limit on the diagrams is 20dB under the reference level measured In-Band for each channel

5.5.7. Test result: passed

5.6. General Limit - Radiated field strength emissions below 30 MHz

5.6.1. Test location and equipment

| | | | |
|-----------------|--|--|---|
| test location | <input checked="" type="checkbox"/> CETECOM Essen (Chapter. 2.2.1) | <input type="checkbox"/> Please see Chapter. 2.2.2 | <input type="checkbox"/> Please see Chapter. 2.2.3 |
| test site | <input checked="" type="checkbox"/> 441 EMI SAR | <input checked="" type="checkbox"/> 487 SAR NSA | |
| receiver | <input type="checkbox"/> 377 ESCS30 | <input checked="" type="checkbox"/> 001 ESS | <input type="checkbox"/> 489 ESU 40 <input type="checkbox"/> 620 ESU 26 |
| spectr. analys. | <input type="checkbox"/> 584 FSU | <input type="checkbox"/> 120 FSEM | <input type="checkbox"/> 264 FSEK |
| antenna | <input checked="" type="checkbox"/> 574 BTA-L | <input type="checkbox"/> 133 EMCO3115 | <input type="checkbox"/> 302 BBHA9170 <input type="checkbox"/> 289 CBL 6141 <input type="checkbox"/> 030 HFH-Z2 <input type="checkbox"/> 477 GPS |
| signalling | <input type="checkbox"/> 392 MT8820A | <input type="checkbox"/> 371 CBT32 | <input type="checkbox"/> 547 CMU <input type="checkbox"/> 594 CMW |
| otherwise | <input type="checkbox"/> 400 FTC40x15E | <input type="checkbox"/> 401 FTC40x15E | <input type="checkbox"/> 110 USB LWL <input checked="" type="checkbox"/> 482 Filter Matrix |
| DC power | <input type="checkbox"/> 456 EA 3013A | <input checked="" type="checkbox"/> 612 E3632A | <input type="checkbox"/> 459 EA 2032-50 <input type="checkbox"/> 268 EA- 3050 <input checked="" type="checkbox"/> 494 AG6632A <input type="checkbox"/> 498 NGPE |
| multimeter | <input checked="" type="checkbox"/> Fluke 112 | | |
| line voltage | <input type="checkbox"/> 230 V 50 Hz via public mains | <input checked="" type="checkbox"/> 13.5 V DC | |

5.6.2. Requirements

| FCC | Part 15, Subpart C, §15.205 & §15.209 | | | |
|-----------------|--|-----------------------|---|--|
| ISED | RSS-Gen, Issue 5 | | | |
| ANSI | C63.10-2013 | | | |
| Frequency [MHz] | Field strength limit | | Distance [m] | Remarks |
| | [μ V/m] | [dB μ V/m] | | |
| 0.009 – 0.490 | 2400/f (kHz) | 67.6 – 20Log(f) (kHz) | 300 | Correction factor used due to measurement distance of 3 m |
| 0.490 – 1.705 | 24000/f (kHz) | 87.6 – 20Log(f) (kHz) | 30 | Correction factor used due to measurement distance of 3 m |
| 1.705 – 30 | 30 | 29.5 | 30 | Correction factor used due to measurement distance of 3 m |
| ISED | <input checked="" type="checkbox"/> RSS-Gen: Issue 5: §8.9 Table | | <input type="checkbox"/> ICES-001, Issue 2 / CISPR11 ((Table 3b – induction cooking appliances) | |
| 9-490 kHz | 63.7/F (F in kHz) (H-Field) (μ A/m) | | 0.009-0.070 MHz | 69 (dBuA/m) |
| 490-1705 kHz | 63.7/F (F in kHz) (μ A/m) | | 0.070-0.1485 MHz | 69 (dBuA/m) decreasing linearly with logarithm of frequency to 39 (dBuA/m) |
| 1705-30 MHz | 0.08 (μ A/m) | | 0.1485-4.0 MHz | 39 dBuA/m decreasing linearly with logarithm of frequency to 3 (dBuA/m) |
| | | | 4.0-30 MHz | 3 (dBuA/m) |

5.6.3. Test condition and test set-up

| | | | |
|---------------------------------------|---|---|--|
| Signal link to test system (if used): | <input type="checkbox"/> air link | <input type="checkbox"/> cable connection | <input checked="" type="checkbox"/> none |
| EUT-grounding | <input checked="" type="checkbox"/> none | <input type="checkbox"/> with power supply | <input type="checkbox"/> additional connection |
| Equipment set up | <input checked="" type="checkbox"/> table top | | <input type="checkbox"/> floor standing |
| Climatic conditions | Temperature: (22 \pm 3°C) | | Rel. humidity: (40 \pm 20)% |
| EMI-Receiver or Analyzer Settings | Scan data | <input checked="" type="checkbox"/> 9 – 150 kHz RBW/VBW = 200 Hz Scan step = 80 Hz <input checked="" type="checkbox"/> 150 kHz – 30 MHz RBW/VBW = 9 kHz Scan step = 4 kHz <input type="checkbox"/> other: | |
| | Scan-Mode Detector Mode: Sweep-Time | <input checked="" type="checkbox"/> 6 dB EMI-Receiver Mode <input type="checkbox"/> 3dB Spectrum analyser Mode Peak (pre-measurement) and Quasi-PK/Average (final if applicable) Repetitive-Scan, max-hold Coupled – calibrated display if continuous signal otherwise adapted to EUT's individual transmission duty-cycle | |
| General measurement procedures | Please see chapter "Test system set-up radiated magnetic field measurements below 30 MHz" | | |

5.6.4. Measurement Results

The results are presented below in summary form only. For more information please consult the diagrams included in annex 1.

Table of measurement results:

| Diagram No. | Carrier Channel | | Frequency range | Set-up no. | OP-mode no. | Remark | Used detector | | | Result |
|-------------|-----------------|-----|-----------------|------------|-------------|--------------|-------------------------------------|--------------------------|--------------------------|--------|
| | Range | No. | | | | | PK | AV | QP | |
| 2.01a | Low | 01 | 9 kHz-30 MHz | 1 | 1 | EUT standing | <input checked="" type="checkbox"/> | <input type="checkbox"/> | <input type="checkbox"/> | passed |
| 2.01b | Low | | 9 kHz-30 MHz | | | EUT laying | <input checked="" type="checkbox"/> | <input type="checkbox"/> | <input type="checkbox"/> | passed |
| 2.02a | Middle | 20 | 9 kHz-30 MHz | 1 | 1 | EUT standing | <input checked="" type="checkbox"/> | <input type="checkbox"/> | <input type="checkbox"/> | passed |
| 2.02b | Middle | | 9 kHz-30 MHz | | | EUT laying | <input checked="" type="checkbox"/> | <input type="checkbox"/> | <input type="checkbox"/> | passed |
| 2.03a | High | 39 | 9 kHz-30 MHz | 1 | 1 | EUT standing | <input checked="" type="checkbox"/> | <input type="checkbox"/> | <input type="checkbox"/> | passed |
| 2.03b | High | | 9 kHz-30 MHz | | | EUT laying | <input checked="" type="checkbox"/> | <input type="checkbox"/> | <input type="checkbox"/> | passed |

5.6.5. Correction factors due to reduced meas. distance (f< 30 MHz)

The used correction factors when the measurement distance is reduced compared to regulatory measurement distance, are calculated according Extrapolation formulas valid for EUT's with maximum dimension of $0.625 \times \lambda$. Formula 2+3+4 as presented in ANSI C63.10, Chapter 6.4.4 are used for the calculations of proper extrapolation factors.

| Frequency -Range | f [kHz/MHz] | Lambda [m] | Far-Field Point [m] | Distance Limit accord. 15.209 [m] | 1st Condition (d _{meas} < D _{near-field}) | 2'te Condition (Limit distance bigger d _{near-field}) | Distance Correction accord. Formula |
|------------------|-------------|------------|---------------------|-----------------------------------|--|---|-------------------------------------|
| kHz | 9,00E+03 | 33333,33 | 5305,17 | 300 | fulfilled | not fulfilled | -80,00 |
| | 1,00E+04 | 30000,00 | 4774,65 | | not fulfilled | -80,00 | |
| | 2,00E+04 | 15000,00 | 2387,33 | | not fulfilled | -80,00 | |
| | 3,00E+04 | 10000,00 | 1591,55 | | not fulfilled | -80,00 | |
| | 4,00E+04 | 7500,00 | 1193,66 | | not fulfilled | -80,00 | |
| | 5,00E+04 | 6000,00 | 954,93 | | not fulfilled | -80,00 | |
| | 6,00E+04 | 5000,00 | 795,78 | | not fulfilled | -80,00 | |
| | 7,00E+04 | 4285,71 | 682,09 | | not fulfilled | -80,00 | |
| | 8,00E+04 | 3750,00 | 595,83 | | not fulfilled | -80,00 | |
| | 9,00E+04 | 3333,33 | 530,52 | | not fulfilled | -80,00 | |
| | 1,00E+05 | 3000,00 | 477,47 | | not fulfilled | -80,00 | |
| | 1,25E+05 | 2400,00 | 381,97 | | not fulfilled | -80,00 | |
| | 2,00E+05 | 1500,00 | 238,73 | | fulfilled | -78,02 | |
| | 3,00E+05 | 1000,00 | 159,16 | | fulfilled | -74,49 | |
| | 4,00E+05 | 750,00 | 119,37 | | fulfilled | -72,00 | |
| | 4,90E+05 | 612,24 | 97,44 | | fulfilled | -70,23 | |
| | 5,00E+05 | 600,00 | 95,49 | | not fulfilled | -40,00 | |
| | 6,00E+05 | 500,00 | 79,58 | | not fulfilled | -40,00 | |
| 7,00E+05 | 428,57 | 68,21 | not fulfilled | -40,00 | | | |
| 8,00E+05 | 375,00 | 59,68 | not fulfilled | -40,00 | | | |
| 9,00E+05 | 333,33 | 53,05 | not fulfilled | -40,00 | | | |
| MHz | 1,00 | 300,00 | 47,75 | 30 | fulfilled | not fulfilled | -40,00 |
| | 1,59 | 188,50 | 30,00 | | fulfilled | not fulfilled | -40,00 |
| | 2,00 | 150,00 | 23,87 | | fulfilled | fulfilled | -38,02 |
| | 3,00 | 100,00 | 15,92 | | fulfilled | fulfilled | -34,49 |
| | 4,00 | 75,00 | 11,94 | | fulfilled | fulfilled | -32,00 |
| | 5,00 | 60,00 | 9,55 | | fulfilled | fulfilled | -30,06 |
| | 6,00 | 50,00 | 7,96 | | fulfilled | fulfilled | -28,47 |
| | 7,00 | 42,86 | 6,82 | | fulfilled | fulfilled | -27,13 |
| | 8,00 | 37,50 | 5,97 | | fulfilled | fulfilled | -25,97 |
| | 9,00 | 33,33 | 5,31 | | fulfilled | fulfilled | -24,95 |
| | 10,00 | 30,00 | 4,77 | | fulfilled | fulfilled | -24,04 |
| | 10,60 | 28,30 | 4,50 | | fulfilled | fulfilled | -23,53 |
| | 11,00 | 27,27 | 4,34 | | fulfilled | fulfilled | -23,21 |
| | 12,00 | 25,00 | 3,98 | | fulfilled | fulfilled | -22,45 |
| | 13,56 | 22,12 | 3,52 | | fulfilled | fulfilled | -21,39 |
| | 15,00 | 20,00 | 3,18 | | fulfilled | fulfilled | -20,51 |
| | 15,92 | 18,85 | 3,00 | | fulfilled | fulfilled | -20,00 |
| | 17,00 | 17,65 | 2,81 | | not fulfilled | fulfilled | -20,00 |
| | 18,00 | 16,67 | 2,65 | | not fulfilled | fulfilled | -20,00 |
| | 20,00 | 15,00 | 2,39 | | not fulfilled | fulfilled | -20,00 |
| | 21,00 | 14,29 | 2,27 | | not fulfilled | fulfilled | -20,00 |
| | 23,00 | 13,04 | 2,08 | | not fulfilled | fulfilled | -20,00 |
| | 25,00 | 12,00 | 1,91 | | not fulfilled | fulfilled | -20,00 |
| | 27,00 | 11,11 | 1,77 | | not fulfilled | fulfilled | -20,00 |
| 29,00 | 10,34 | 1,65 | not fulfilled | fulfilled | -20,00 | | |
| 30,00 | 10,00 | 1,59 | not fulfilled | fulfilled | -20,00 | | |

5.7. General Limit - Radiated field strength emissions, 30 MHz - 1 GHz

5.7.1. Test location and equipment

| | | | | | |
|-----------------|--|--|---|---|---|
| test location | <input checked="" type="checkbox"/> CETECOM Essen (Chapter. 2.2.1) | <input type="checkbox"/> Please see Chapter. 2.2.2 | | <input type="checkbox"/> Please see Chapter. 2.2.3 | |
| test site | <input checked="" type="checkbox"/> 441 EMI SAR | <input checked="" type="checkbox"/> 487 SAR NSA | | | |
| receiver | <input type="checkbox"/> 377 ESCS30 | <input checked="" type="checkbox"/> 001 ESS | <input type="checkbox"/> 489 ESU 40 | <input type="checkbox"/> 620 ESU 26 | |
| spectr. analys. | <input type="checkbox"/> 584 FSU | <input type="checkbox"/> 120 FSEM | <input type="checkbox"/> 264 FSEK | | |
| antenna | <input checked="" type="checkbox"/> 574 BTA-L | <input type="checkbox"/> 133 EMCO3115 | <input type="checkbox"/> 302 BBHA9170 | <input type="checkbox"/> 289 CBL 6141 | <input type="checkbox"/> 030 HFH-Z2 <input type="checkbox"/> 477 GPS |
| signalling | <input type="checkbox"/> 392 MT8820A | <input type="checkbox"/> 371 CBT32 | <input type="checkbox"/> 547 CMU | <input type="checkbox"/> 594 CMW | |
| otherwise | <input type="checkbox"/> 400 FTC40x15E | <input type="checkbox"/> 401 FTC40x15E | <input type="checkbox"/> 110 USB LWL | <input checked="" type="checkbox"/> 482 Filter Matrix | |
| DC power | <input type="checkbox"/> 456 EA 3013A | <input checked="" type="checkbox"/> 612 E3632A | <input type="checkbox"/> 459 EA 2032-50 | <input type="checkbox"/> 268 EA- 3050 | <input checked="" type="checkbox"/> 494 AG6632A <input type="checkbox"/> 498 NGPE |
| line voltage | <input type="checkbox"/> 230 V 50 Hz via public mains | | <input checked="" type="checkbox"/> 13.5 V DC | | |

5.7.2. Requirements/Limits

| | | | |
|------------------|-----------------|---|---------------------------|
| FCC | | <input type="checkbox"/> Part 15 Subpart B, §15.109, class B <input checked="" type="checkbox"/> Part 15 Subpart C, §15.209 @ frequencies defined in §15.205 | |
| ISED (IC) | | <input checked="" type="checkbox"/> RSS-Gen., Issue 5, Chapter 8.9, Table 5+6+7 (licence-exempt radio apparatus) | |
| ANSI | | <input type="checkbox"/> C63.4-2014 <input checked="" type="checkbox"/> C63.10-2013 | |
| Limit | Frequency [MHz] | Radiated emissions limits, 3 meters | |
| | | QUASI Peak [μ V/m] | QUASI-Peak [dB μ V/m] |
| | 30 - 88 | 100 | 40.0 |
| | 88 - 216 | 150 | 43.5 |
| | 216 - 960 | 200 | 46.0 |
| above 960 | 500 | 54.0 | |

5.7.3. Restricted bands of operation (FCC §15.205/ RSS-Gen, Issue 5, Chapter 8.10, Table 7)

| MHz | MHz | GHz |
|-----------------------------|-------------------------|-------------|
| 0.090-0.110 | 156.7-156.9 | 9.0-9.2 |
| 0.495-0.505 | 162.0125-167.17 | 9.3-9.5 |
| 2.1735-2.1905 | 167.72-173.2 | 10.6-12.7 |
| 3.020-3.026 (Canada only) | 240-285 | 13.25-13.4 |
| 4.125-4.128 | 322-335.4 | 14.47-14.5 |
| 4.17725 - 4.17775 | 399.9-410 | 15.35-16.2 |
| 4.20725-4.20775 | 608-614 | 17.7-21.4 |
| 5.677 - 5.683 (Canada only) | 960-1240 | 22.01-23.12 |
| 6.215-6.218 | 1300-1427 | 23.6-24.0 |
| 6.26775-6.26825 | 960-1427 (only Canada) | 31.2-31.8 |
| 6.31175-6.31225 | 1435-1626.5 | 36.43-36.5 |
| 8.291-8.294 | 1645.5-1646.5 | Above 38.6 |
| 8.362-8.366 | 1660-1710 | -- |
| 8.37625-8.38675 | 1718.8-1722.2 | -- |
| 8.41425-8.41475 | 2200-2300 | -- |
| 12.29-12.293 | 2310-2390 | -- |
| 12.51975-12.52025 | 2483.5-2500 | -- |
| 12.57675-12.57725 | 2690-2900 | -- |
| 13.36-13.41 | 2655-2900 (only Canada) | -- |
| 16.42-16.423 | 3260-3267 | -- |
| 16.69475-16.69525 | 3332-3339 | -- |
| 16.80425-16.80475 | 3345.8-3358 | -- |
| 25.5-25.67 | 3500-4400 (only Canada) | -- |
| 37.5-38.25 | 3600-4400 | -- |
| 73-74.6 | 4500-5150 | -- |
| 74.8-75.2 | 5350-5460 | -- |
| 108-121.94 | 7250-7750 | -- |
| 123-138 | 8025-8500 | -- |
| 108-138 (only Canada) | -- | -- |
| 149.9-150.05 | -- | -- |
| 156.52475-156.52525 | -- | -- |

Remark: only spurious emissions are allowed within these frequency bands not exceeding the limits per §15.209/RSS-Gen.

5.7.4. Test condition and measurement test set-up

| | | | |
|---------------------------------------|---|--|--|
| Signal link to test system (if used): | <input type="checkbox"/> air link | <input type="checkbox"/> cable connection | <input checked="" type="checkbox"/> none |
| EUT-grounding | <input checked="" type="checkbox"/> none | <input type="checkbox"/> with power supply | <input type="checkbox"/> additional connection |
| Equipment set up | <input checked="" type="checkbox"/> table top 0.8m height | | <input type="checkbox"/> floor standing |
| Climatic conditions | Temperature: (22±3°C) | | Rel. humidity: (40±20)% |
| EMI-Receiver (Analyzer) Settings | Scan frequency range: <input checked="" type="checkbox"/> 30 – 1000 MHz <input type="checkbox"/> other: Scan-Mode: <input checked="" type="checkbox"/> 6 dB EMI-Receiver Mode <input type="checkbox"/> 3 dB spectrum analyser mode Detector: Peak / Quasi-peak RBW/VBW: 100 kHz/300 kHz Mode: Repetitive-Scan, max-hold Scan step: 80 kHz Sweep-Time: Coupled – calibrated display if continuous tx-signal otherwise adapted to EUT's individual duty-cycle | | |
| General measurement procedures | Please see chapter "Test system set-up for electric field measurement in the range 30 MHz to 1 GHz" | | |

5.7.5. MEASUREMENT RESULTS

The results are presented below in summary form only. For more information please consult the diagrams included in annex 1.

Table of measurement results:

| Diagram no. | Carrier Channel | | Frequency range | Set-up no. | OP-mode no. | Remark | Used detector | | | Result |
|-------------|-----------------|-----|-----------------|------------|-------------|-------------------------------|-------------------------------------|--------------------------|-------------------------------------|---------|
| | Range | No. | | | | | PK | AV | QP | |
| 3.00 | - | - | - | - | - | For noise level applicability | <input checked="" type="checkbox"/> | <input type="checkbox"/> | <input checked="" type="checkbox"/> | Initial |
| 3.01a | Low | 01 | 30 MHz – 1 GHz | 1 | 1 | EUT standing position | <input checked="" type="checkbox"/> | <input type="checkbox"/> | <input checked="" type="checkbox"/> | passed |
| 3.01b | Low | | | | | EUT laying position | <input checked="" type="checkbox"/> | <input type="checkbox"/> | <input checked="" type="checkbox"/> | passed |
| 3.02a | Middle | 20 | 30 MHz – 1 GHz | 1 | 1 | EUT standing position | <input checked="" type="checkbox"/> | <input type="checkbox"/> | <input checked="" type="checkbox"/> | passed |
| 3.02b | Middle | | | | | EUT laying position | <input checked="" type="checkbox"/> | <input type="checkbox"/> | <input checked="" type="checkbox"/> | passed |
| 3.03a | High | 39 | 30 MHz – 1 GHz | 1 | 1 | EUT standing position | <input checked="" type="checkbox"/> | <input type="checkbox"/> | <input checked="" type="checkbox"/> | passed |
| 3.03b | High | | | | | EUT laying position | <input checked="" type="checkbox"/> | <input type="checkbox"/> | <input checked="" type="checkbox"/> | passed |

Remark:

5.7.6. VERDICT: PASS

5.8. General Limit – Radiated field strength emissions, above 1 GHz

5.8.1. Test location and equipment FAR

| | | | | | | |
|-----------------|---|--|---|--|--|--------------------------|
| test site | <input type="checkbox"/> 441 EMI SAR | <input type="checkbox"/> 348 EMI cond. | <input checked="" type="checkbox"/> 443 EMI FAR | <input type="checkbox"/> 347 Radio.lab. | <input type="checkbox"/> 337 OATS | |
| spectr. analys. | <input type="checkbox"/> 584 FSU | <input type="checkbox"/> 120 FSEM | <input type="checkbox"/> 264 FSEK | <input checked="" type="checkbox"/> 489 ESU 40 | <input checked="" type="checkbox"/> 714 FSW | |
| antenna meas | <input type="checkbox"/> 574 BTA-L | <input type="checkbox"/> 289 CBL 6141 | <input type="checkbox"/> 608 HL 562 | <input checked="" type="checkbox"/> 549 HL025 | <input checked="" type="checkbox"/> 302 BBHA9170 | |
| antenna subst | <input type="checkbox"/> 071 HUF-Z2 | <input type="checkbox"/> 020 EMCO3115 | <input type="checkbox"/> 063 LP 3146 | | <input type="checkbox"/> 303 BBHA9170 | |
| signalling | <input type="checkbox"/> 392 MT8820A | <input type="checkbox"/> 371 CBT32 | <input type="checkbox"/> 547 CMU200 | <input type="checkbox"/> 594 CMW | | |
| DC power | <input type="checkbox"/> 086 LNG50-10 | <input type="checkbox"/> 087 EA3013 | <input checked="" type="checkbox"/> 354 NGPE 40 | <input type="checkbox"/> 349 car battery | <input type="checkbox"/> 350 Car battery | <input type="checkbox"/> |
| line voltage | <input type="checkbox"/> 230 V 50 Hz via public mains | | <input type="checkbox"/> 060 120 V 60 Hz via PAS 5000 | | | |
| SupplyVoltage | <input checked="" type="checkbox"/> 13.5 V DC | | | | | |

5.8.2. Requirements/Limits

| FCC | <input type="checkbox"/> Part 15 Subpart B, §15.109 class B <input checked="" type="checkbox"/> Part 15 Subpart C, §15.209 for frequencies defined in §15.205 <input type="checkbox"/> Part 15 Subpart C, §15.407(b)(1)(2)(3)(4) | | | |
|--|--|-------------|-------------|---------------|
| ISED | <input checked="" type="checkbox"/> RSS-Gen., Issue 5, Chapter 8.9, Table 5+6+7 (transmitter licence exempt) | | | |
| ANSI | <input type="checkbox"/> C63.4-2014 <input checked="" type="checkbox"/> C63.10-2013 | | | |
| Frequency [MHz] | Limits | | | |
| | AV [µV/m] | AV [dBµV/m] | Peak [µV/m] | Peak [dBµV/m] |
| above 1 GHz for frequencies as defined in §15.205 or RSS-Gen | 500 | 54.0 | 5000 | 74.0 |

5.8.3. Test condition and measurement test set-up

| | | | |
|---------------------------------------|--|--|--|
| Signal link to test system (if used): | <input type="checkbox"/> air link | <input type="checkbox"/> cable connection | <input checked="" type="checkbox"/> none |
| EUT-grounding | <input checked="" type="checkbox"/> none | <input type="checkbox"/> with power supply | <input type="checkbox"/> additional connection |
| Equipment set up | <input checked="" type="checkbox"/> table top 1.5m height | | <input type="checkbox"/> floor standing |
| Climatic conditions | Temperature: (22±3°C) | | Rel. humidity: (40±20)% |
| Spectrum-Analyzer settings | Scan frequency range: <input checked="" type="checkbox"/> 1 – 18 GHz <input checked="" type="checkbox"/> 18 – 26 GHz <input type="checkbox"/> 18 – 40 GHz <input type="checkbox"/> other: Scan-Mode: <input checked="" type="checkbox"/> 6 dB EMI-Receiver Mode <input type="checkbox"/> 3 dB Spectrum analyser Mode Detector: Peak and Average RBW/VBW: 1 MHz / 3 MHz Mode: Repetitive-Scan, max-hold Scan step: 400 kHz Sweep-Time: Coupled – calibrated display if CW signal otherwise adapted to EUT’s individual duty-cycle | | |
| General measurement procedures | Please see chapter “Test system set-up for radiated electric field measurements above 1 GHz” | | |

5.8.4. Measurement Results

The results are presented below in summary form only. For more information please consult the diagrams included in annex 1.

| Diagram no. | Carrier Channel | | Frequency range | Set-up no. | OP-mode no. | Remark | Used detector | | | Result |
|-------------|-----------------|-----|-----------------|------------|-------------|--------|-------------------------------------|-------------------------------------|--------------------------|--------|
| | Range | No. | | | | | PK | AV | QP | |
| 4.01 | Low | 01 | 1-18GHz | 1 | 1 | -- | <input checked="" type="checkbox"/> | <input checked="" type="checkbox"/> | <input type="checkbox"/> | passed |
| 4.04 | Low | | 18-26GHz | | | | <input checked="" type="checkbox"/> | <input checked="" type="checkbox"/> | <input type="checkbox"/> | passed |
| 4.02 | Middle | 20 | 1-18GHz | 1 | 1 | -- | <input checked="" type="checkbox"/> | <input checked="" type="checkbox"/> | <input type="checkbox"/> | passed |
| 4.05 | Middle | | 18-26GHz | | | | <input checked="" type="checkbox"/> | <input checked="" type="checkbox"/> | <input type="checkbox"/> | passed |
| 4.03 | High | 39 | 1-18GHz | 1 | 1 | -- | <input checked="" type="checkbox"/> | <input checked="" type="checkbox"/> | <input type="checkbox"/> | passed |
| 4.06 | High | | 18-26GHz | | | | <input checked="" type="checkbox"/> | <input checked="" type="checkbox"/> | <input type="checkbox"/> | passed |

Remark: see diagrams in annex 1 for more details

5.8.5. VERDICT: PASS

5.9. Radiated Band-Edge compliance, field strength measurements accord. §15.205

5.9.1. Test location and equipment FAR

| | | | | | | |
|-----------------|---|--|--|--|--|----------------------------------|
| test site | <input type="checkbox"/> 441 EMI SAR | <input type="checkbox"/> 348 EMI cond. | <input checked="" type="checkbox"/> 443 EMI FAR | <input type="checkbox"/> 347 Radio.lab. | <input type="checkbox"/> 337 OATS | <input type="checkbox"/> |
| spectr. analys. | <input type="checkbox"/> 584 FSU | <input type="checkbox"/> 120 FSEM | <input type="checkbox"/> 264 FSEK | <input checked="" type="checkbox"/> 489 ESU 40 | <input type="checkbox"/> | <input type="checkbox"/> |
| antenna meas | <input type="checkbox"/> 574 BTA-L | <input type="checkbox"/> 289 CBL 6141 | <input type="checkbox"/> 608 HL 562 | <input checked="" type="checkbox"/> 549 HL025 | <input type="checkbox"/> 302 BBHA9170 | <input type="checkbox"/> 477 GPS |
| antenna meas | <input type="checkbox"/> 123 HUF-Z2 | <input type="checkbox"/> 132 HUF-Z3 | <input type="checkbox"/> 030 HFH-Z2 | <input type="checkbox"/> | <input type="checkbox"/> | <input type="checkbox"/> |
| antenna subst | <input type="checkbox"/> 071 HUF-Z2 | <input type="checkbox"/> 020 EMCO3115 | <input type="checkbox"/> 063 LP 3146 | <input type="checkbox"/> 303 BBHA9170 | <input type="checkbox"/> | <input type="checkbox"/> |
| multimeter | <input type="checkbox"/> 341 Fluke 112 | <input type="checkbox"/> | <input type="checkbox"/> | <input type="checkbox"/> | <input type="checkbox"/> | <input type="checkbox"/> |
| signaling | <input type="checkbox"/> 371 CBT32 | <input type="checkbox"/> 298 CMU 200 | <input type="checkbox"/> | <input type="checkbox"/> | <input type="checkbox"/> | <input type="checkbox"/> |
| DCpower | <input type="checkbox"/> 086 LNG50-10 | <input type="checkbox"/> 087 EA3013 | <input checked="" type="checkbox"/> 354 NGPE 40 | <input type="checkbox"/> 349 car battery | <input type="checkbox"/> 350 Car battery | <input type="checkbox"/> |
| SupplyVoltage | <input checked="" type="checkbox"/> 13.5 V DC | | | | | |
| line voltage | <input type="checkbox"/> 230 V 50 Hz via public mains | | <input type="checkbox"/> 060 120 V 60 Hz via PAS 5000. | | | |

5.9.2. Requirements/Limits

| | | | | |
|-----------------|--|----------------|----------------|------------------|
| FCC | <input type="checkbox"/> Part 15 Subpart B, §15.109 class B <input checked="" type="checkbox"/> Part 15 Subpart C, §15.209 @ frequencies defined in §15.205 | | | |
| ISED | <input checked="" type="checkbox"/> RSS-Gen: Issue 2: §8.9 Table 5 + §8.10 Table 7 | | | |
| ANSI | <input type="checkbox"/> C63.4-2009 <input checked="" type="checkbox"/> C63.10-2013 | | | |
| Frequency [MHz] | Right Band-Edge Limits beginning on 2483.5MHz@3 meters | | | |
| | AV [µV/m] | AV [dBµV/m] | Peak [µV/m] | Peak [dBµV/m] |
| above 1 GHz | 500 | 54.0 | 5000 | 74.0 |

5.9.3. MEASUREMENT METHOD FOR BAND-EDGE:

For uncritical results where a measurement bandwidth of 1MHz can clearly show the compliance without influencing the results, a field strength measurement was performed only.

For critical results a Marker-Delta marker method was used for showing compliance to restricted bands according §15.205. The method is according ANSI 63.10:2013 “Marker-Delta method”, §6.9.3. The method consists of three independent steps:

- Step:** Prior to the measurement the fundamental radiated In-Band field strength was performed. The determined value is used as reference value.
- Step:** Second step consist of finding the relative attenuation between the fundamental emission and the maximum local out-of-band emission (within 2 MHz range around the band edge either on the band-edge directly or some modulation product if the level is greater than that on the band-edge) when measured with lower resolution bandwidth.
- Step:** The delta value recorded in step 2 will be subtracted from value recorded in step 1, thus giving the required field strength at the band-edge. This value must fulfil the requirements for radiated spurious emissions in restricted bands in §15.205 with the general limits of §15.209.

5.9.4. RESULTS – LEFT BAND-EDGE

| Diagramm no. | Channel no. | Restricted band ? | Fundamental Value [dBuV/m] | | Peak-Value at Band-Edge [dBuV/m] | Difference [dB] | Limit [dBc] | Margin [dB] | Verdict | Remark: |
|--------------|-------------|-------------------|----------------------------|---------------|----------------------------------|-----------------|-------------|-------------|---------|---------------|
| | | | Peak-Value | Average-Value | | | | | | |
| 9.02 | 1 | no | 91.55 | 82.80 | 50.75 | 40.80 | 20 | 20.80 | PASS | BT-LE - PRBS9 |

5.9.5. RESULTS – RIGHT BAND-EDGE

| Diagramm no. | Channel no. | Restricted band ? | Fundamental Value [dBuV/m] | | Value at Band-Edge [dBuV/m] | | Limits [dBuV/m] | | Duty-Cycle Correction for AV-detector [dB] | Margin [dB] | | Verdict | Remark: |
|--------------|-------------|-------------------|----------------------------|---------------|-----------------------------|---------------|-----------------|---------------|--|-------------|---------|---------|---------------|
| | | | Peak-Value | Average-Value | Peak-Value | Average-Value | Peak-Value | Average-Value | | Peak | Average | | |
| 9.01 | 11 | yes | 93.12 | 89.96 | 57.92 | 46.61 | 74 | 54 | 2.49166 | 16.08 | 4.90 | PASS | BT-LE - PRBS9 |

5.9.6. VERDICT: PASS

5.10. Measurement uncertainties

The reported uncertainties are calculated based on the standard uncertainty multiplied with the appropriate coverage factor **k**, such that a confidence level of approximately 95% is achieved.

For uncertainty determination, each component used in the concrete measurement set-up was taken in account and it's contribution to the overall uncertainty according it's statistical distribution calculated.

Following table shows expectable uncertainties for each measurement type performed.

| RF-Measurement | Reference | Frequency range | Calculated uncertainty based on a confidence level of 95% | | | | | | Remarks |
|--|--------------|--------------------|---|--------|------|------|------|----|---|
| Conducted emissions (U _{CISPR}) | CISPR 16-2-1 | 9 kHz - 150 kHz | 4.0 dB | | | | | | - |
| | | 150 kHz - 30 MHz | 3.6 dB | | | | | | |
| Radiated emissions Enclosure | CISPR 16-2-3 | 30 MHz - 1 GHz | 4.2 dB | | | | | | E-Field |
| | | 1 GHz - 18 GHz | 5.1 dB | | | | | | |
| Disturbance power | CISPR 16-2-2 | 30 MHz - 300 MHz | - | | | | | | - |
| Power Output radiated | - | 30 MHz - 4 GHz | 3.17 dB | | | | | | Substitution method |
| Power Output conducted | - | Set-up No. | Cel-C1 | Cel-C2 | BT1 | W1 | W2 | -- | - |
| | | 9 kHz - 12.75 GHz | N/A | 0.60 | 0.7 | 0.25 | N/A | -- | |
| | | 12.75 - 26.5GHz | N/A | 0.82 | -- | N/A | N/A | -- | |
| Conducted emissions on RF-port | - | 9 kHz - 2.8 GHz | 0.70 | N/A | 0.70 | N/A | 0.69 | -- | N/A - not applicable |
| | | 2.8 GHz - 12.75GHz | 1.48 | N/A | 1.51 | N/A | 1.43 | -- | |
| | | 12.75 GHz - 18GHz | 1.81 | N/A | 1.83 | N/A | 1.77 | -- | |
| | | 18 GHz - 26.5GHz | 1.83 | N/A | 1.85 | N/A | 1.79 | -- | |
| Power density | - | 1 – 2.8GHz | 1.40 dB | | | | | | -- |
| Occupied bandwidth | - | 9 kHz - 4 GHz | 0.1272 ppm (Delta Marker) | | | | | | Frequency error |
| | | | 1.0 dB | | | | | | Power |
| Emission bandwidth | - | 9 kHz - 4 GHz | 0.1272 ppm (Delta Marker) | | | | | | Frequency error |
| | | | See above: 0.70 dB | | | | | | Power |
| Frequency stability | - | 9 kHz - 20 GHz | 0.0636 ppm | | | | | | - |
| Radiated emissions Enclosure | - | 150 kHz - 30 MHz | 5.0 dB | | | | | | Magnetic field E-field Substitution |
| | | 30 MHz - 1 GHz | 4.2 dB | | | | | | |
| | | 1 GHz - 20 GHz | 3.17 dB | | | | | | |

Table: measurement uncertainties, valid for conducted/radiated measurements

6. Abbreviations used in this report

| The abbreviations | |
|-------------------|---|
| ANSI | American National Standards Institute |
| AV , AVG, CAV | Average detector |
| EIRP | Equivalent isotropic radiated power, determined within a separate measurement |
| EGPRS | Enhanced General Packet Radio Service |
| EUT | Equipment Under Test |
| FCC | Federal Communications Commission, USA |
| IC | Industry Canada |
| n.a. | not applicable |
| Op-Mode | Operating mode of the equipment |
| PK | Peak |
| RBW | resolution bandwidth |
| RF | Radio frequency |
| RSS | Radio Standards Specification, Documents from Industry Canada |
| Rx | Receiver |
| TCH | Traffic channel |
| Tx | Transmitter |
| QP | Quasi peak detector |
| VBW | Video bandwidth |
| ERP | Effective radiated power |

7. Accreditation details of CETECOM's laboratories and test sites

| Ref.-No. | Accreditation Certificate | Valid for laboratory area or test site | Accreditation Body |
|---------------------------------|---|---|---|
| - | D-PL-12047-01-01 | All laboratories and test sites of CETECOM GmbH, Essen | DAkkS, Deutsche Akkreditierungsstelle GmbH |
| 337 487 558 348 348 | (MRA US-EU 0003) | Radiated Measurements 30 MHz to 1 GHz, 3 m / 10 m (OATS) Radiated Measurements 30 MHz to 1 GHz, 3 m (SAR) Radiated Measurements above 1 GHz, 3 m (FAR) Mains Ports Conducted Interference Measurements Telecommunication Ports Conducted Interference Measur. | FCC, Federal Communications Commission Laboratory Division, USA |
| 337 487 550 558 | -- 3462D-2 3462D-2 3462D-3 | Radiated Measurements 30 MHz to 1 GHz, 3 m / 10 m (OATS) Radiated Measurements 30 MHz to 1 GHz, 3 m (SAR) Radiated Measurements 1 GHz to 6 GHz, 3 m (SAR) Radiated Measurements above 1 GHz, 3 m (FAR) | ISED, Industry Canada Certification and Engineering Bureau |
| 487 550 348 348 | R- 4452 G- 20013 C- 20009 T- 20006 | Radiated Measurements 30 MHz to 1 GHz, 3 m (SAR) Radiated Measurements 1 GHz to 6 GHz, 3 m (SAR) Mains Ports Conducted Interference Measurements Telecommunication Ports Conducted Interference Measur. | VCCI, Voluntary Control Council for Interference by Information Technology Equipment, Japan |

OATS = Open Area Test Site, SAR = Semi Anechoic Room, FAR = Fully Anechoic Room

8. Instruments and Ancillary

8.1. Used equipment “CTC”

The “Ref.-No” in the left column of the following tables allows the clear identification of the laboratory equipment.

8.1.1. Test software and firmware of equipment

| Ref.-No. | Equipment | Type | Serial-No. | Version of Firmware or Software during the test |
|----------|---|------------------------|----------------|--|
| 012 | Signal Generator (EMS-cond.) | SMY 01 | 839069/027 | Firm.= V 2.02 |
| 013 | Power Meter (EMS cond.) | NRVD | 839111/003 | Firm.= V 1.51 |
| 017 | Digital Radiocommunication Tester | CMD 60 M | 844365/014 | Firmware = V 3.52 .22.01.99, DECT = D2.87 13.01.99 |
| 119 | RT Harmonics Analyzer dig. Flickermeter | B10 | G60547 | Firm.= V 3.1DHG |
| 261 | Thermal Power Sensor | NRV-Z55 | 825083/0008 | EPROM-Datum 02.12.04, SE EE 1 B |
| 262 | Power Meter | NRV-S | 825770/0010 | Firm.= 2.6 |
| 295 | Racal Digital Radio Test Set | 6103 | 1572 | UNIT Firmware= 4.04, SW-Main=4.04, SW-BBP=1.04, SW-DSP=1.02, Hardboot=1.02, Softboot=2.02 |
| 298 | Univ. Radio Communication Tester | CMU 200 | 832221/091 | R&S Test Firmware =3.53 /3.54 (current Testsoftw. f. all band used |
| 323 | Digital Radiocommunication Tester | CMD 55 | 825878/0034 | Firm.= 3.52 .22.01.99 |
| 335 | CTC-EMS-Conducted | System EMS Conducted | - | EMC 32 V 8.52 |
| 340 | Digital Radiocommunication Tester | CMD 55 | 849709/037 | Firm.= 3.52 .22.01.99 |
| 366 | Ultra Compact Simulator | UCS 500 M4 | V0531100594 | Firm. UCS 500=001925/3.06a02, rc=ISMIEC 4.10 |
| 371 | Bluetooth Tester | CBT32 | 100153 | CBT V5_30+ SW-Option K55, K57 |
| 377 | EMI Test Receiver | ESCS 30 | 100160 | Firm.= 2.30, OTP= 02.01, GRA= 02.36 |
| 378 | Broadband RF Field Monitor | RadiSense III | 03D00013SNO-08 | Firm.= V.03D13 |
| 389 | Digital Multimeter | Keithley 2000 | 0583926 | Firm. = A13 (Mainboard) A02 (Display) |
| 392 | Radio Communication Tester | MT8820A | 6K00000788 | Firm.= 4.50 #005, IPL=4.01#001, OS=4.02#001, GSM=4.41#013, W-CDMA= 4.54#004, scenario= |
| 436 | Univ. Radio Communication Tester | CMU 200 | 103083 | R&S Test Firmware Base=5.14, Mess-Software= GSM:5.14 WCDMA:5.14 (current Testsoftw. F. all band |
| 441 | CTC-SAR-EMI Cable Loss | System EMI field (SAR) | - | EMC 32 Version 8.52 |
| 442 | CTC-SAR-EMS | System EMS field (SAR) | - | EMC 32 Version 8.40 |
| 443 | CTC-FAR-EMI-RSE | System CTC-FAR-EMI-RSE | - | Spuri 7.2.5 or EMC 32 Ver. 9.15.00 |
| 444 | CTC-FAR-EMS field | System-EMS-Field (FAR) | - | EMC 32 Version 9.15.00 |
| 460 | Univ. Radio Communication Tester | CMU 200 | 108901 | R&S Test Firmware Base=5.14, GSM=5.14 WCDMA=5.14 (current Testsoftw.,f. all band to be used, |
| 489 | EMI Test Receiver | ESU40 | 1000-30 | Firmware=4.43 SP3, Bios=V5.1-16-3, Spec. =01.00 |
| 491 | ESD Simulator dito | ESD dito | dito307022 | V 2.30 |
| 524 | Voltage Drop Simulator | VDS 200 | 0196-16 | Software Nr: 000037 Version V4.20a01 |
| 526 | Burst Generator | EFT 200 A | 0496-06 | Software Nr. 000034 Version V2.32 |
| 527 | Micro Pulse Generator | MPG 200 B | 0496-05 | Software-Nr. 000030 Version V2.43 |
| 528 | Load Dump Simulator | LD 200B | 0496-06 | Software-Nr. 000031 Version V2.35a01 |
| 546 | Univ. Radio Communication Tester | CMU 200 | 106436 | R&S Test Firmware Base=5.14, GSM=5.14 WCDMA=5.14 (current Testsoftw.,f. all band to be used |
| 547 | Univ. Radio Communication Tester | CMU 200 | 835390/014 | R&S Test Firmware Base=V5.1403 (current Testsoftw., f. all band used, GSM = 5.14 WCDMA: = 5.14 |
| 584 | Spectrum Analyzer | FSU 8 | 100248 | 2.82_SP3 |
| 597 | Univ. Radio Communication Tester | CMU 200 | 100347 | R&S Test Firmware Base=5.01, GSM=5.02 WCDMA= not installed, Mainboard= μP1=V.850 |
| 607 | Signal Generator | SMR 20 | 832033/011 | V1.25 |
| 620 | EMI Test Receiver | ESU 26 | 100362 | 4.43_SP3 |
| 642 | Wideband Radio Communication Tester | CMW 500 | 126089 | Setup V03.26, Test programm component V03.02.20 |
| 670 | Univ. Radio Communication Tester | CMU 200 | 106833 | μP1 =V8.50, Firmware = V.20 |
| 689 | Vector Signal Generator | SMU200 | 100970 | 02.20.360.142 |
| 692 | Bluetooth Tester | CBT 32 | 100236 | CBT V 5.40, FW: V.2.41 (FPGA Digital, V. 3.09 FPGA RF) |
| 693 | Test System | TS8997 | -- | SW: EMC32/WMS32 version 10.50.00 HW: _OSP120 Base unit (S/N=106833) ; FSU26 (Ref. Nr. 683) ; SMU 200 (Ref. Nr. 689) ; SMF 100A (Ref. Nr. 687) |
| 699 | Audio Analyzer | UPL16 | 833494/005 | 3.06 |

8.1.2. Single instruments and test systems

| Ref.-No. | Equipment | Type | Serial-No. | Manufacturer | Interval of calibration | Remark | Cal due |
|----------|---|------------------------------|------------------------|---------------------------------|-------------------------|--------|------------|
| 005 | AC - LISN (50 Ohm/50µH, test site 1) | ESH2-Z5 | 861741/005 | Rohde & Schwarz | 12 M | - | 23.05.2020 |
| 007 | Single-Line V-Network (50 Ohm/5µH) | ESH3-Z6 | 892563/002 | Rohde & Schwarz | 12 M | - | 23.05.2020 |
| 009 | Power Meter (EMS-radiated) | NRV | 863056/017 | Rohde & Schwarz | 24 M | - | 23.05.2021 |
| 016 | Line Impedance Simulating Network | Op. 24-D | B6366 | Spitzenberger+Spies | 36 M | - | 22.05.2022 |
| 020 | Horn Antenna 18 GHz (Subst 1) | 3115 | 9107-3699 | EMCO | 36/12 M | - | 31.07.2021 |
| 021 | Loop Antenna (H-Field) | 6502 | 9206-2770 | EMCO | 36 M | - | 30.05.2021 |
| 033 | RF-current probe (100kHz-30MHz) | ESH2-Z1 | 879581/18 | Rohde & Schwarz | 24 M | - | 23.05.2021 |
| 057 | relay-switch-unit (EMS system) | RSU | 494440/002 | Rohde & Schwarz | pre-m | 1a | |
| 060 | power amplifier (DC-2kHz) | PAS 5000 | B6363 | Spitzenberger+Spies | - | 3 | |
| 066 | notch filter (WCDMA; FDD1) | WRCT 1900/2200-5/40-10EEK | 5 | Wainwright GmbH | 12 M | 1g | 16.11.2019 |
| 086 | DC - power supply, 0 -10 A | LNG 50-10 | - | Heinzinger Electronic | pre-m | 2 | |
| 087 | DC - power supply, 0 -5 A | EA-3013 S | - | Elektro Automatik | pre-m | 2 | |
| 091 | USB-LWL-Converter | OLS-1 | 007/2006 | Ing. Büro Scheiba | - | 4 | |
| 099 | passive voltage probe | ESH2-Z3 | 299.7810.52 | Rohde & Schwarz | 36 M | - | 30.05.2021 |
| 100 | passive voltage probe | Probe TK 9416 | without | Schwarzbeck | 36 M | - | 30.05.2021 |
| 110 | USB-LWL-Converter | OLS-1 | - | Ing. Büro Scheiba | - | 4 | |
| 119 | RT Harmonics Analyzer dig. Flickermeter | B10 | G60547 | BOCONSULT | 36 M | - | 22.05.2022 |
| 133 | horn antenna 18 GHz (Meas 1) | 3115 | 9012-3629 | EMCO | 36 M | 1c | 10.03.2020 |
| 134 | horn antenna 18 GHz (Subst 2) | 3115 | 9005-3414 | EMCO | 36 M | - | 10.03.2020 |
| 248 | attenuator | SMA 6dB 2W | - | Radiall | pre-m | 2 | |
| 249 | attenuator | SMA 10dB 10W | - | Radiall | pre-m | 2 | |
| 252 | attenuator | N 6dB 12W | - | Radiall | pre-m | 2 | |
| 256 | attenuator | SMA 3dB 2W | - | Radiall | pre-m | 2 | |
| 257 | hybrid | 4031C | 04491 | Narda | pre-m | 2 | |
| 260 | hybrid coupler | 4032C | 11342 | Narda | pre-m | 2 | |
| 261 | Thermal Power Sensor | NRV-Z55 | 825083/0008 | Rohde & Schwarz | 24 M | - | 30.05.2020 |
| 262 | Power Meter | NRV-S | 825770/0010 | Rohde & Schwarz | 24 M | - | 30.05.2020 |
| 265 | peak power sensor | NRV-Z33, Model 04 | 840414/009 | Rohde & Schwarz | 24 M | - | 30.05.2020 |
| 266 | Peak Power Sensor | NRV-Z31, Model 04 | 843383/016 | Rohde & Schwarz | 24 M | - | 30.05.2020 |
| 267 | notch filter GSM 850 | WRCA 800/960-6EEK | 9 | Wainwright GmbH | pre-m | 2 | |
| 270 | termination | 1418 N | BB6935 | Weinschel | pre-m | 2 | |
| 271 | termination | 1418 N | BE6384 | Weinschel | pre-m | 2 | |
| 272 | attenuator (20 dB) 50 W | Model 47 | BF6239 | Weinschel | pre-m | 2 | |
| 273 | attenuator (10 dB) 100 W | Model 48 | BF9229 | Weinschel | pre-m | 2 | |
| 274 | attenuator (10 dB) 50 W | Model 47 (10 dB) 50 W | BG0321 | Weinschel | pre-m | 2 | |
| 275 | DC-Block | Model 7003 (N) | C5129 | Weinschel | pre-m | 2 | |
| 276 | DC-Block | Model 7006 (SMA) | C7061 | Weinschel | pre-m | 2 | |
| 279 | power divider | 1515 (SMA) | LH855 | Weinschel | pre-m | 2 | |
| 287 | pre-amplifier 25MHz - 4GHz | AMF-2D-100M4G-35-10P | 379418 | Miteq | 12 M | 1c | 16.11.2019 |
| 291 | high pass filter GSM 850/900 | WHJ 2200-4EE | 14 | Wainwright GmbH | 12 M | 1c | 16.11.2019 |
| 298 | Univ. Radio Communication Tester | CMU 200 | 832221/091 | Rohde & Schwarz | pre-m | 3 | |
| 300 | AC LISN (50 Ohm/50µH, 1-phase) | ESH3-Z5 | 892 239/020 | Rohde & Schwarz | 12 M | - | 22.05.2020 |
| 301 | attenuator (20 dB) 50W, 18GHz | 47-20-33 | AW0272 | Lucas Weinschel | pre-m | 2 | |
| 302 | horn antenna 40 GHz (Meas 1) | BBHA9170 | 155 | Schwarzbeck | 36 M | - | 14.03.2020 |
| 303 | horn antenna 40 GHz (Subst 1) | BBHA9170 | 156 | Schwarzbeck | 36 M | - | 20.03.2020 |
| 331 | Climatic Test Chamber -40/+180 Grad | HC 4055 | 43146 | Heraeus Vötsch | 24 M | - | 10.01.2021 |
| 341 | Digital Multimeter | Fluke 112 | 81650455 | Fluke | 24 M | - | 30.05.2020 |
| 342 | Digital Multimeter | Voltcraft M-4660A | IB 255466 | Voltcraft | 24 M | - | 23.05.2021 |
| 347 | laboratory site | radio lab. | - | - | - | 5 | |
| 348 | laboratory site | EMI conducted | - | - | - | 5 | |
| 354 | DC - Power Supply 40A | NGPE 40/40 | 448 | Rohde & Schwarz | pre-m | 2 | |
| 357 | power sensor | NRV-Z1 | 861761/002 | Rohde & Schwarz | 24 M | - | 21.05.2021 |
| 373 | Single-Line V-Network (50 Ohm/5µH) | ESH3-Z6 | 100535 | Rohde & Schwarz | 12 M | - | 22.05.2020 |
| 377 | EMI Test Receiver | ESCS 30 | 100160 | Rohde & Schwarz | 12 M | - | 22.05.2020 |
| 389 | Digital Multimeter | Keithley 2000 | 0583926 | Keithley | pre-m | - | |
| 392 | Radio Communication Tester | MT8820A | 6K0000788 | Anritsu | 12 M | - | 01.07.2020 |
| 396 | Thermo/Hygrometer | Thermo/Hygrometer | - | Conrad | 24 M | - | 09.01.2021 |
| 405 | Thermo/Hygrometer | OPUS 10 THI | 126.0604.0003.3.3.3.22 | LUFFT Mess u. Regeltechnik GmbH | 24 M | - | 30.03.2019 |
| 431 | Model 7405 | Near-Field Probe Set | 9305-2457 | EMCO | - | 4 | |
| 436 | Univ. Radio Communication Tester | CMU 200 | 103083 | Rohde & Schwarz | 12 M | - | 25.05.2020 |
| 439 | UltraLog-Antenna | HL 562 | 100248 | Rohde & Schwarz | 36 M | - | 10.03.2020 |
| 441 | CTC-SAR-EMI Cable Loss | System EMI field (SAR) Cable | - | CETECOM | 12 M | 5 | 05.06.2017 |
| 443 | CTC-FAR-EMI-RSE | System CTC-FAR-EMI-RSE | - | ETS-Lindgren / CETECOM | 12 M | 5 | 16.11.2019 |
| 448 | notch filter WCDMA_FDD II | WRCT 1850.0/2170.0- | 5 | Wainwright | 12 M | 1c | 16.11.2019 |

| Ref.-No. | Equipment | Type | Serial-No. | Manufacturer | Interval of calibration | Remark | Cal due |
|----------|---|-------------------------------|--------------|------------------------|-------------------------|--------|------------|
| | | 5/40-10SSK | | Instruments GmbH | | | |
| 449 | notch filter WCDMA FDD V | WRCT 824.0/894.0-5/40-8SSK | 1 | Wainwright | 12 M | 1c | 16.11.2019 |
| 454 | Oscilloscope | HM 205-3 | 9210 P 29661 | Hameg | - | 4 | |
| 456 | DC-Power supply 0-5 A | EA 3013 S | 207810 | Elektro Automatik | pre-m | 2 | |
| 459 | DC -Power supply 0-5 A , 0-32 V | EA-PS 2032-50 | 910722 | Elektro Automatik | pre-m | 2 | |
| 460 | Univ. Radio Communication Tester | CMU 200 | 108901 | Rohde & Schwarz | 12 M | - | 30.05.2020 |
| 463 | Universal source | HP3245A | 2831A03472 | Agilent | - | 4 | |
| 466 | Digital Multimeter | Fluke 112 | 89210157 | Fluke USA | 24 M | - | 30.05.2020 |
| 467 | Digital Multimeter | Fluke 112 | 89680306 | Fluke USA | 36 M | - | 30.05.2021 |
| 468 | Digital Multimeter | Fluke 112 | 90090455 | Fluke USA | 36 M | - | 30.04.2021 |
| 477 | ReRadiating GPS-System | AS-47 | - | Automotive Cons. Fink | - | 3 | |
| 480 | power meter (Fula) | NRVS | 838392/031 | Rohde & Schwarz | 24 M | - | 30.05.2021 |
| 482 | filter matrix | Filter matrix SAR 1 | - | CETECOM (Brl) | - | 1d | |
| 484 | pre-amplifier 2,5 - 18 GHz | AMF-5D-02501800-25-10P | 1244554 | Miteq | 12 M | - | 16.11.2019 |
| 487 | System CTC NSA-Verification SAR-EMI | System EMI field (SAR) NSA | - | ETS Lindgren / CETECOM | 24 M | - | 16.04.2021 |
| 489 | EMI Test Receiver | ESU40 | 1000-30 | Rohde & Schwarz | 12 M | - | 30.06.2020 |
| 502 | band reject filter | WRCG 1709/1786-1699/1796- | SN 9 | Wainwright | pre-m | 2 | |
| 503 | band reject filter | WRCG 824/849-814/859-60/10SS | SN 5 | Wainwright | pre-m | 2 | |
| 512 | notch filter GSM 850 | WRCA 800/960-02/40-6EEK | SN 24 | Wainwright | 12 M | 1c | 16.11.2019 |
| 517 | relais switch matrix | HF Relais Box Keithley System | SE 04 | Keithley | pre-m | 2 | |
| 523 | Digital Multimeter | L4411A | MY46000154 | Agilent | 24 M | - | 23.05.2021 |
| 529 | 6 dB Broadband resistive power divider | Model 1515 | LH 855 | Weinschel | pre-m | 2 | |
| 530 | 10 dB Broadband resistive power divider | R 416110000 | LOT 9828 | - | pre-m | 2 | |
| 549 | Log.Per-Antenna | HL025 | 1000060 | Rohde & Schwarz | 36/12 M | - | 31.07.2021 |
| 550 | System CTC S-VSWR Verification SAR-EMI | System EMI Field SAR S-VSWR | - | ETS Lindgren/CETECOM | 24 M | - | 30.10.2021 |
| 552 | high pass filter 2,8-18GHz | WHKX 2.8/18G-10SS | 4 | Wainwright | 12 M | 1c | 16.11.2019 |
| 557 | System CTC-OTA-2 | R&S TS8991 | - | Rohde & Schwarz | 12 M | 5 | 24.01.2020 |
| 574 | Biconilog Hybrid Antenna | BTA-L | 980026L | Frankonia | 36/12 M | - | 03.05.2022 |
| 584 | Spectrum Analyzer | FSU 8 | 100248 | Rohde & Schwarz | pre-m | - | |
| 594 | Wideband Radio Communication Tester | CMW 500 | 101757 | Rohde & Schwarz | 12 M | - | 26.06.2020 |
| 597 | Univ. Radio Communication Tester | CMU 200 | 100347 | Rohde & Schwarz | pre-m | - | |
| 600 | power meter | NRVD (Reserve) | 834501/018 | Rohde & Schwarz | 24 M | - | 30.05.2021 |
| 602 | peak power sensor | NRV-Z32 (Reserve) | 835080 | Rohde & Schwarz | 24 M | - | |
| 611 | DC power supply | E3632A | KR 75305854 | Agilent | pre-m | 2 | |
| 612 | DC power supply | E3632A | MY 40001321 | Agilent | pre-m | 2 | |
| 613 | Attenuator | R416120000 20dB 10W | Lot. 9828 | Radiall | pre-m | 2 | |
| 616 | Digitalmultimeter | Fluke 177 | 88900339 | Fluke | 24 M | - | 30.05.2020 |
| 617 | Power Splitter/Combiner | ZFSC-2-2-S+ | S F987001108 | Mini Circuits | - | 2 | |
| 618 | Power Splitter/Combiner | 50PD-634 | 600994 | JFW Industries USA | - | 2 | |
| 619 | Power Splitter/Combiner | 50PD-634 | 600995 | JFW Industries, USA | - | 3 | |
| 620 | EMI Test Receiver | ESU 26 | 100362 | Rohde-Schwarz | 12 M | - | 30.05.2020 |
| 621 | Step Attenuator 0-139 dB | RSP | 100017 | Rohde & Schwarz | pre-m | 2 | |
| 625 | Generic Test Load USB | Generic Test Load USB | - | CETECOM | - | 2 | |
| 634 | Spectrum Analyzer | FSM (HF-Unit) | 826188/010 | Rohde & Schwarz | pre-m | 2 | |
| 637 | High Speed HDMI with Ethernet 1m | HDMI cable with Ethernet 1m | - | Kogilink | - | 2 | |
| 638 | HDMI Kabel with Ethernet 1,5 m flach | HDMI cable with Ethernet 1,5m | - | Reichelt | - | 2 | |
| 640 | HDMI cable 2m rund | HDMI cable 2m rund | - | Reichelt | - | 2 | |
| 641 | HDMI cable with Ethernet | Certified HDMI cable with | - | PureLink | - | 2 | |
| 644 | Amplifierer | ZX60-2534M+ | SN865701299 | Mini-Circuits | - | - | |
| 670 | Univ. Radio Communication Tester | CMU 200 | 106833 | Rohde & Schwarz | 24 M | - | 30.05.2020 |
| 671 | DC-power supply 0-5 A | EA-3013S | - | Elektro Automatik | pre-m | 2 | |
| 678 | Power Meter | NRP | 101638 | Rohde&Schwarz | pre-m | - | |
| 683 | Spectrum Analyzer | FSU 26 | 200571 | Rohde & Schwarz | 12 M | - | 30.05.2020 |
| 687 | Signal Generator | SMF 100A | 102073 | Rohde&Schwarz | 12 M | - | 30.05.2020 |
| 688 | Pre Amp | JS-18004000-40-8P | 1750117 | Miteq | pre-m | - | |
| 690 | Spectrum Analyzer | FSU | 100302/026 | Rohde&Schwarz | 24 M | - | 30.05.2021 |
| 691 | OSP120 Base Unit | OSP120 | 106833 | Rohde & Schwarz | 12 M | - | 30.05.2020 |
| 692 | Bluetooth Tester | CBT 32 | 100236 | Rohde & Schwarz | 36 M | - | 29.05.2020 |
| 693 | TS8997 | CTC-Radio Lab 1_TS8997 | - | Rohde&Schwarz | 12 M | 5 | 07.01.2020 |

| Ref.-No. | Equipment | Type | Serial-No. | Manufacturer | Interval of calibration | Remark | Cal due |
|----------|-----------------------------------|--------------------------------|------------------------|--------------------------------|-------------------------|--------|------------|
| 697 | Power Splitter | ZN4PD-642W-S+ | 165001445 | Mini-Circuits | - | 2 | |
| 701 | CMW500 wide. Radio Comm. | CMW500 | 158150 | Rohde & Schwarz | 24 M | - | 30.07.2020 |
| 703 | INNCO Antennen Mast | MA 4010-KT080-XPET-ZSS3 | MA4170-KT100-XPET-ZSS3 | INNCO | pre-m | - | |
| 704 | INNCON Controller | CO 3000-4port | CO3000/933/384105 16/L | INNCO Systems GmBh | pre-m | - | |
| 711 | Harmonic Mixer 90 GHz - 140GHz | RPG FS-Z140 | 101004 | RPG | 36 M | - | 22.02.2020 |
| 712 | Harmonic Mixer 75 GHz - 110GHz | FS-Z110 | 101468 | Rohde & Schwarz | 36 M | - | 22.02.2020 |
| 713 | Harmonic Mixer, 50 GHz - 75GHz | FS-Z75 | 101022 | Rohde & Schwarz | 24 M | - | 05.07.2021 |
| 714 | Signal Analyzer 67GHz | FSW67 | 104023 | Rohde & Schwarz | 24 M | - | 04.07.2021 |
| 715 | Harmonic Mixer, 140 GHz - 220GHz | FS-Z220 | 101009 | RPG Radiometer Physics | 36 M | - | 03.08.2020 |
| 716 | Harmonic Mixer 220 GHz to 325 GHZ | FS-Z325 | 101005 | RPG Radiometer Physics | 36 M | - | 13.02.2020 |
| 764 | Spectrum Analyzer | FSU 26 | 200152 | Rohde & Schwarz | 12 M | - | 30.07.2020 |
| 748 | Pickett-Potter Horn Antenna | FH-PP 4060 | 010001 | Radiometer Physics | 36 M | - | |
| 750 | Pickett-Potter Horn Antenna | FH-PP 220 | 010011 | Radiometer Physics | 36 M | - | |
| 751 | Digital Optical System | optoCAN-FD Transceiver | 17-010416 | mk-messtechnik GmbH | - | - | |
| 752 | Digital Optical System | optoCAN-FD Transceiver | 17-010083 | mk-messtechnik GmbH | - | - | |
| 753 | Digital Optical System | optoCAN-FD Transceiver | 17-010084 | mk-messtechnik GmbH | - | - | |
| 754 | Digital Optical System | optoCAN-FD Transceiver | 17-010415 | mk-messtechnik GmbH | - | - | |
| 755 | Digital Optical System | optoLAN-100-MAX Transceiver | 17-010795 | mk-messtechnik GmbH | - | - | |
| 757 | WIDEBAND RADIO COMMUNICATION | CMW500 | 163673 | Rohde&Schwarz | 12 M | - | 30.05.2020 |
| 758 | Signal Generator | SMU 200A | 100754 | Rohde & Schwarz | 24 M | - | 11.10.2020 |
| 781 | Power Supply | PS 2042-10 B | 2815450369 | Elektro-Automatik GmbH & Co.KG | - | - | |
| 782 | Power Supply | PS 2042-10 B | 2815450348 | lektro-Automatik GmbH & Co.KG | - | - | |
| 783 | Spectrum Analyzer | FSU 26 | 100414 | Rohde & Schwarz | 12 M | - | 30.05.2020 |
| 784 | Power Supply | NGSM 32/10 | 00196 | Rohde & Schwarz | 12 M | - | |
| 785 | RSP | RF Step Attenuator 0...139.9dB | 860712/012 | Rohde & Schwarz | 12 M | - | |
| 786 | SAR Probe | ES3DV3 | 3340 | Speag | 36 M | - | 14.02.2021 |
| 787 | OSP | OSP B157WX | 101264 | Rohde & Schwarz | 24 M | - | 30.05.2020 |
| 788 | Precision Omnidirectional Dipole | POD 618 | 6182558/Q | Seibersdorf Laboratories | 36 M | - | 30.06.2021 |
| 789 | Precision Omnidirectional Dipole | POD 16 | 162496/Q | Seibersdorf Laboratories | 36 M | - | 30.06.2021 |
| 790 | Horn Antenna | ASY-SGH-124-SMA | 29F14182337 | Antenna System Solutions | 36 M | - | 08.10.2021 |
| 791 | Pickett-Potter Horn Antenna | FH-PP-325 | 10024 | Radiometer Physics | 36 M | - | |
| 792 | Pickett-Potter Horn Antenna | FH-PP 075 | 10006 | Radiometer Physics | 36 M | - | |
| 793 | Pickett-Potter Horn Antenna | FH-PP 140 | 10008 | Radiometer Physics | 36 M | - | |
| 794 | Pickett-Potter Horn Antenna | FH-PP 110 | 10014 | Radiometer Physics | 36 M | - | |
| 795 | SGH Antenna | SGH-26-WR10 | 1144 | Anteral S.L. | 36 M | - | |
| 798 | WR-22 Rectangular Gain Horn | SAR-2309-22-S2 | 13254-01 | SAGE Millimeter, Inc. | 36 M | - | |
| 799 | Transceiver | optoLAN-Gb | 18-014746 | mk messtechnik | pre-m | - | |
| 801 | Spectrum Analyzer | FSP 13 | 100960 | Rohde & Schwarz | 24 M | - | 14.01.2021 |
| 802 | Exposure Level Tester | ELT-400 | O-0026 | NARDA Safety Solutions | 24 M | - | 30.01.2021 |
| 803 | Probe | ELT probe 3cm² | O-0026 | Narda Safety Test Solution | 24 M | - | 30.01.2021 |
| 805 | Thermo-Hygrometer | Web-Thermo-Hygrometer | 02749814 | W&T | 24 M | - | |
| 806 | AC2600 Smart Wifi Router | Netgear Nighthawk x4S | 5K5188590067B | Netgear | - | - | |
| 807 | Direct Coupler | Direct Coupler C-05020-10 | 511 | ET Industries | - | - | |
| 808 | Diode Power Sensor | NRV-Z1 | 829894/001 | Rohde & Schwarz | 24 M | - | 24.05.2021 |
| 809 | Standard gain Horn Antenna | WR-159 Horn Antenna | - | Pasternack Enterprises Inc. | - | - | |

| Note / remarks | | Calibrated during system calibration: |
|----------------|-----|---|
| | 1a | System CTC-SAR-EMS (Ref.-No. 442) |
| | 1b | System-CTC-EMS-Conducted (Ref.-No. 335) |
| | 1c | System CTC-FAR-EMI-RSE (Ref.-No. 443) |
| | 1d | System CTC-SAR-EMI (Ref.-No. 441) |
| | 1e | System CTC-OATS (EMI radiated) (Ref.-No. 337) |
| | 1 f | System CTC-CTIA-OTA (Ref.-No. 420) |
| | 1 g | System CTC-FAR-EMS (Ref.-No. 444) |
| | 2 | Calibration or equipment check immediately before measurement |
| | 3 | Regulatory maintained equipment for functional check or support purpose |
| | 4 | Ancillary equipment without calibration e.g. mechanical equipment or monitoring equipment |
| | 5 | Test System |

| | | |
|-------------------------|---------|---|
| Interval of calibration | 12 M | 12 month |
| | 24 M | 24 month |
| | 36 M | 36 month |
| | 24/12 M | Calibration every 24 months, between this every 12 months internal validation |
| | 36/12 M | Calibration every 36 months, between this every 12 months internal validation |
| | Pre-m | Check before starting the measurement |
| | - | Without calibration |

9. Versions of test reports (change history)

| Version | Applied changes | Date of release |
|---------|----------------------------------|-----------------|
| -- | Initial release | 2019-11-07 |
| C1 | Update on results in chapter 5.3 | 2019-11-27 |

END OF TEST REPORT