



TEST REPORT

No. 3-20835062

Applicant *Equipment under test*

Kathrein Automotive GmbH & Co. KG *LTE Kompensator US;*
6803145-01 218898-10 50110260
FCC-ID: 2ACC7LTECOMPB0

Test Standard(s)

FCC part 20, section 20.21 Signal Boosters



Accredited Testing Laboratory

The testing laboratory (area of testing) is accredited according to DIN EN ISO/IEC 17025 (2005) by the Deutsche Akkreditierungsstelle GmbH (DAkkS).

The accreditation is valid for the scope of testing procedures as stated in the accreditation certificate with the registration number: D-PL-12076-01-01

CETECOM GmbH

Im Teelbruch 116 / 45219 Essen / Germany
Registered in Essen, Germany / Reg.-No.: HRB Essen 8984

Phone: +49 681 598 0 / Fax: +49 681 598 9075

Internet: www.cetecom.com / E-mail: info@cetecom.com

Table of content

Table of content.....	2
Disclaimer and Notes.....	3
1. Summary of Test Results.....	4
2. Administrative Data.....	5
2.1. Identification of the Testing Laboratory and Test Location.....	5
2.2. Organizational Items.....	6
2.3. Applicant's Details.....	6
2.4. Test Environment.....	6
3. Test Standard(s).....	6
4. Equipment under Test.....	7
4.1. General information.....	7
4.2. Auxiliary Equipment.....	7
4.3. EUT Set Up.....	7
5. Measurements / Detailed Test Results.....	8
5.1. Authorized Frequency Bands.....	8
5.2. Maximum RF Power and Determination of AGC Start Level.....	16
5.3. Gain.....	27
5.4. Intermodulation.....	27
5.5. Out of Band Emission.....	39
5.6. Conducted Spurious Emissions.....	72
5.7. Noise.....	90
5.8. Uplink Inactivity.....	111
5.9. Variable Gain and Uplink Gain Timing.....	115
5.10. Occupied Bandwidth.....	125
5.11. Oscillation Detection and Mitigation Test.....	157
6. Test System.....	182
6.1. System Set Up and Test Procedure.....	182
6.2. Measurement Equipment.....	183
6.3. Measurement Uncertainty.....	183
Annex A: Photographs of Test set up(s).....	185
Annex B: External Photographs of the EUT.....	187

Disclaimer and Notes

The test results of this test report relate exclusively to the test item specified in this test report. CETECOM does not assume responsibility for any conclusions and generalizations drawn from the test results with regard to other specimens or samples of the type of the equipment represented by the test item.

The test report may only be reproduced or published in full. Reproduction or publication of extracts from the report requires the prior written approval of CETECOM.

The testing service provided by CETECOM has been rendered under the current "General Terms and Conditions for CETECOM".

CETECOM will not be liable for any loss or damage resulting from false, inaccurate, inappropriate or incomplete product information provided by the customer.

Under no circumstances does the CETECOM test report include any endorsement or warranty regarding the functionality, quality or performance of any other product or service provided.

Under no circumstances does the CETECOM test report include or imply any product or service warranties from CETECOM, including, without limitation, any implied warranties of merchantability, fitness for purpose, or non-infringement, all of which are expressly disclaimed by CETECOM.

All rights and remedies regarding vendor's products and services for which CETECOM has prepared this test report shall be provided by the party offering such products or services and not by CETECOM.

In no case this test report can be considered as a Letter of Approval.

1. Summary of Test Results

- No deviations from the technical specifications were ascertained
- There were deviations from the technical specifications ascertained
- This test report is only a partial test report. The content and verdict of the performed test cases are listed below

Chapter	KDB Test Case	Reference to FCC part 20 for a consumer wideband booster, cradle type	Limit	Verdict
5.1	7.1 Authorized frequency band verification test	§ 20.21(e)(3) Frequency Bands	Pass	
5.2	7.2 Maximum power measurement test procedure	§ 20.21(e)(8)(i)(D) Power Limits § 20.21(e)(8)(i)(B) Bidirectional Capability § 20.21(e)(8)(ii)(B) Gain Control	17 < p < 30 dBm	Pass
5.3	7.3 Gain		< 23 dB	Pass
5.4	7.4 Intermodulation product test procedure	§ 20.21(e)(8)(i)(F) Intermodulation	-19 dBm	Pass
5.5	7.5 Out-of-band emissions test procedure	§ 20.21(e)(8)(i)(E) Out of Band Emission	-19 dBm	Pass
5.6	7.6 Conducted spurious emissions test procedure	§ 2.1051 Spurious emissions at antenna terminals	-19 dBm	Pass
5.7	7.7 Noise limits test	§ 20.21(e)(8)(i)(A) Noise Limits § 20.21(e)(8)(i)(H) Tr. Power Off	< -70 dBm	Pass
5.8	7.8 Uplink Inactivity	§ 20.21(e)(8)(i)(A) Noise Limits § 20.21(e)(8)(i)(H) Tr. Power Off	< 15 s	Pass
5.9	7.9 Variable booster gain test procedure	§ 20.21(e)(8)(i)(C)(1) Gain Limits § 20.21(e)(8)(ii)(B) Gain Control	6 ...23 dB / 1 s	Pass
5.10	7.10 Occupied bandwidth test procedure	§ 2.1049 Occupied bandwidth	Pass	
5.11	7.11 Oscillation detection test procedure	§ 20.21(e)(8)(ii)(A) Anti-Oscillation	0.3 / 1 / 60 s	Pass
	7.12 Radiated spurious emissions test procedure	§ 2.1053 Field strength of spurious radiation	Separate test report	
	7.13 Spectrum block filtering test procedure	§ 20.21(e)(3) Frequency Bands	Not supported	

Uplink Power and Gain Summary

Frequency Band	Supported signal types	Max Uplink Power	Max Uplink Gain
Band 2: 1900 MHz (PCS)	GSM / CDMA / WCDMA / LTE	19.9	19.7
Band 4: 1.7 GHz	WCDMA / LTE	18.6	19.1
Band 5: 850 MHz (cell band)	GSM / CDMA / WCDMA / LTE	19.9	19.9
Band 12: 700 MHz	LTE	19.2	18.9
Band 13: 800 MHz	LTE	18.0	18.4

i.A. *Thomas Hauck*

.....
 Thomas Hauck
 Responsible for test report

i.V. *Peter Nevermann*

.....
 Dr. Peter Nevermann
 Responsible for laboratory

2. Administrative Data

2.1. Identification of the Testing Laboratory and Test Location

Company name:	CETECOM GmbH
Address:	Im Teelbruch 116 45219 Essen Germany
Responsible for testing laboratory:	Dr. Peter Nevermann
Deputy:	Thomas Hauck

2.2. Organizational Items

Order No.:	20835062 / 15083280
Responsible for test report and project leader:	Dr. Peter Nevermann
Receipt of EUT	04.01.2016
Date(s) of test:	06.01.2016 – 03.03.2016
Date of report:	17.03.2016
Attending persons during test:	Thomas Hauck and Piotr Sardyko
Version of template	V5-SB

2.3. Applicant's Details

Applicant's name:	Kathrein Automotive GmbH & Co. KG
Address:	Anton-Kathrein-Str. 1-3 83004 Rosenheim Germany
Contact person: Email:	Herr T. Toni Ilsanker toni.ilsanker@kathreinautomotive.com

2.4. Test Environment

Temperature:	T _{nom} : + 22 °C / air condition
Relative humidity:	55 % ± 25% rH
Barometric pressure:	not relevant for this kind of testing
Power supply:	V _{nom} : + 12.0 V, DC

3. Test Standard(s)

Test Standard	Version	Test Standard Description
FCC part 20.21	01.10.2014	Signal Boosters
KDB 935210 D03	V04, February 2016	Wideband Consumer Signal Booster Compliance Measurement Guidance

4. Equipment under Test

4.1. General information

Device classification:	Consumer wideband booster, cradle type
Type identification:	LTE Kompensator US
Type of radio transmission:	Bi-directional amplifier
Power supply:	12 V, DC
Temperature range:	
Supported Frequency Bands [MHz] and Modes:	Band 2: 1850 – 1910 / 1930 – 1990 MHz, GSM / CDMA / WCDMA / LTE Band 4: 1710 – 1755 / 2110 - 2155 MHz, WCDMA / LTE Band 5: 824 – 849 / 869 – 894 MHz, GSM / CDMA / WCDMA / LTE Band 12/17: 699 – 716 / 729 – 746 MHz, LTE Band 13: 777 – 787 / 746 – 756 MHz, LTE
Additional system description:	This booster requires a RF signal on its server port for enabling uplink operation. Additional there is on the donor side an antenna key sensor. Therefore during conducted testing a special antenna key simulator must be used (50 Ω device, transparent to RF).

EUT short description*)	EUT	Type	S/N serial number	HW hardware status	SW software status
EUT A	Booster	LTE Kompensator US 6803145-01	358	13611416B01V04	9408675_S01_RC09
EUT B	Booster	LTE Kompensator US 6803145-01	342	13611416B01V04	9408675_S01_RC09

4.2. Auxiliary Equipment

AE short description	Auxiliary Equipment	Type	S/N serial number	HW hardware status	SW software status
AE 1	Antenna key simulator	NAN	NAN	NAN	NAN
AE 2	Antenna				
AE 3	Cradle				

4.3. EUT Set Up

EUT set-up no.*)	Combination of EUT and AE	Remarks
Set 1	EUT A + AE 1	for conducted tests
Set 2	EUT B + AE 2 + AE 3	for radiated tests

*) EUT set-up no. is used to simplify the identification of the EUT set-up in CETECOM test reports.

5. Measurements / Detailed Test Results

The set up and test procedure has been according to FCC KDB 935210 D03: "Wideband Consumer Signal Booster Compliance Measurement Guidance". This booster requires an antenna key and a RF signal on its server port for enabling uplink operation. Therefor the needed RF cabling for testing and other details are provide in the appropriate chapters. All conducted test have been carried out with EUT set number 1 with an antenna key simulator. An automated and calibrated test system has been used as described in chapter 6.

5.1. Authorized Frequency Bands

The activated cable routing for this test in uplink is shown in Fig. 1 and for the downlink in Fig. 2, respectively. Below are summarized in the first table the measured results for the frequency f_0 with maximum gain in each band within the supported frequency band limits (but with 2.5 MHz distance to the band edges) and in the second table the input power level at AGC start as well the AGC start value -3 dB and the related maximum output power in CW mode. The third table shows the input power level at AGC start which has been determined for EUT B for the radiated measurements.

Below are summarized the measured results for uplink and downlink for EUT A for conducted tests

Band	Direction	Frequency range	Frequency f_0
2	up	1850 MHz – 1910 MHz	1879.3 MHz
4	up	1710 MHz – 1755 MHz	1746.2 MHz
5	up	824 MHz – 849 MHz	837.9 MHz
12	up	699 MHz – 716 MHz	701.5 MHz
13	up	777 MHz – 787 MHz	782.9 MHz
2	down	1930 MHz -1990 MHz	1949.0 MHz
4	down	2110 MHz – 2155 MHz	2124.9 MHz
5	down	868 MHz – 894 MHz	882.8 MHz
12	down	729 MHz -746 MHz	734.3 MHz
13	down	746 MHz -768 MHz	752.3 MHz

Below are summarized the measured results for uplink and downlink for EUT A and B for conducted tests in CW mode.

Band	Direction	p_{in} at AGC start CW EUT A	p_{in} at AGC start CW - 3 dB EUT A	p_{in} at AGC start CW EUT B
2	up	-1.54 dBm	-4.54 dBm	-1.68 dBm
4	up	-0.70 dBm	-3.70 dBm	-0.47 dBm
5	up	-1.51 dBm	-4.51 dBm	-1.93 dBm
12	up	0.99 dBm	-2.01 dBm	0.86 dBm
13	up	-0.81 dBm	-3.81 dBm	-0.25 dBm
2	down	-51.95 dBm	-54.95 dBm	-51.41 dBm
4	down	-52.07 dBm	-55.07 dBm	-51.67 dBm
5	down	-52.07 dBm	-55.07 dBm	-51.92 dBm
12	down	-51.63 dBm	-54.63 dBm	-51.83 dBm
13	down	-52.42 dBm	-55.42 dBm	-52.27 dBm

Note: The AGC start results for EUT B has been used as a preparation for the radiated tests

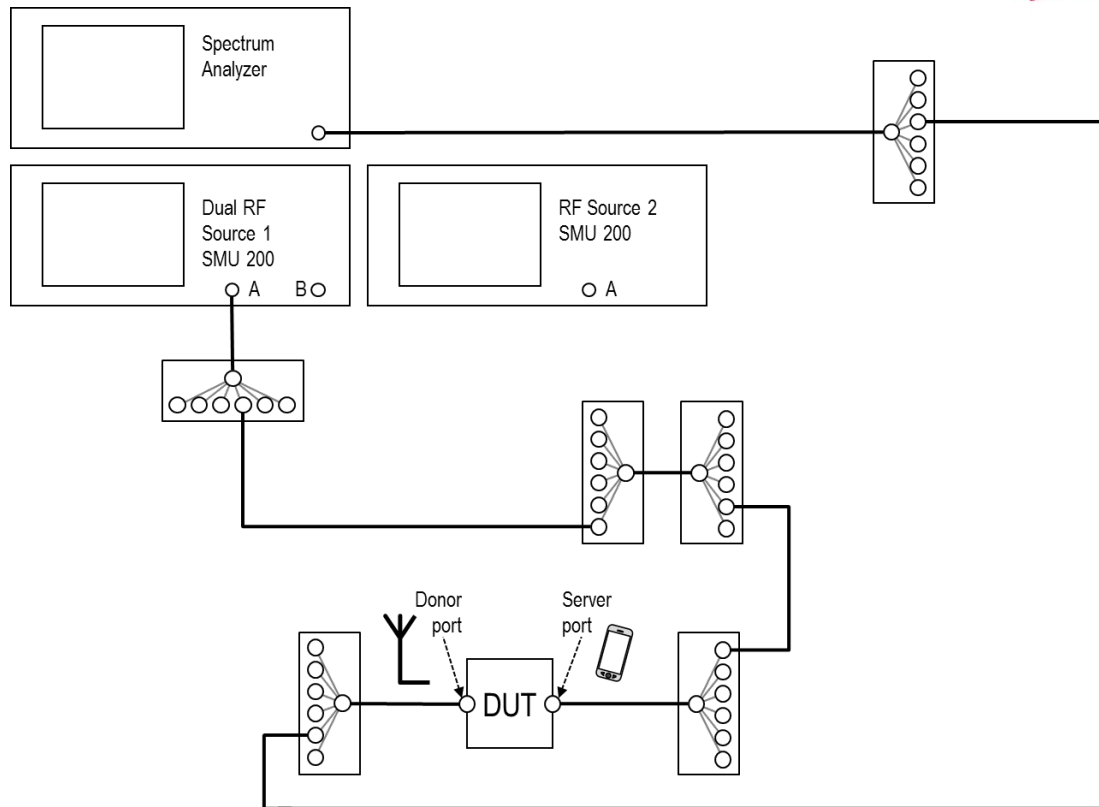

Fig. 1: Set up for frequency response test in uplink.

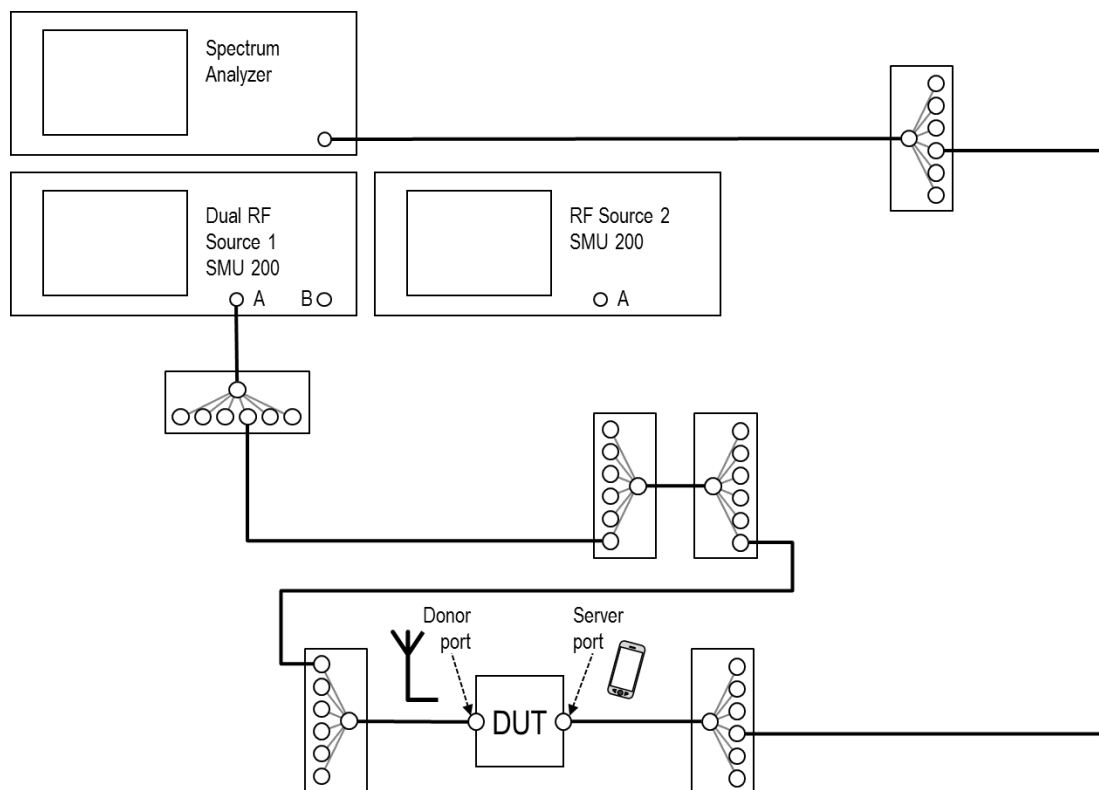

Fig. 2: Set up for frequency response test in downlink.

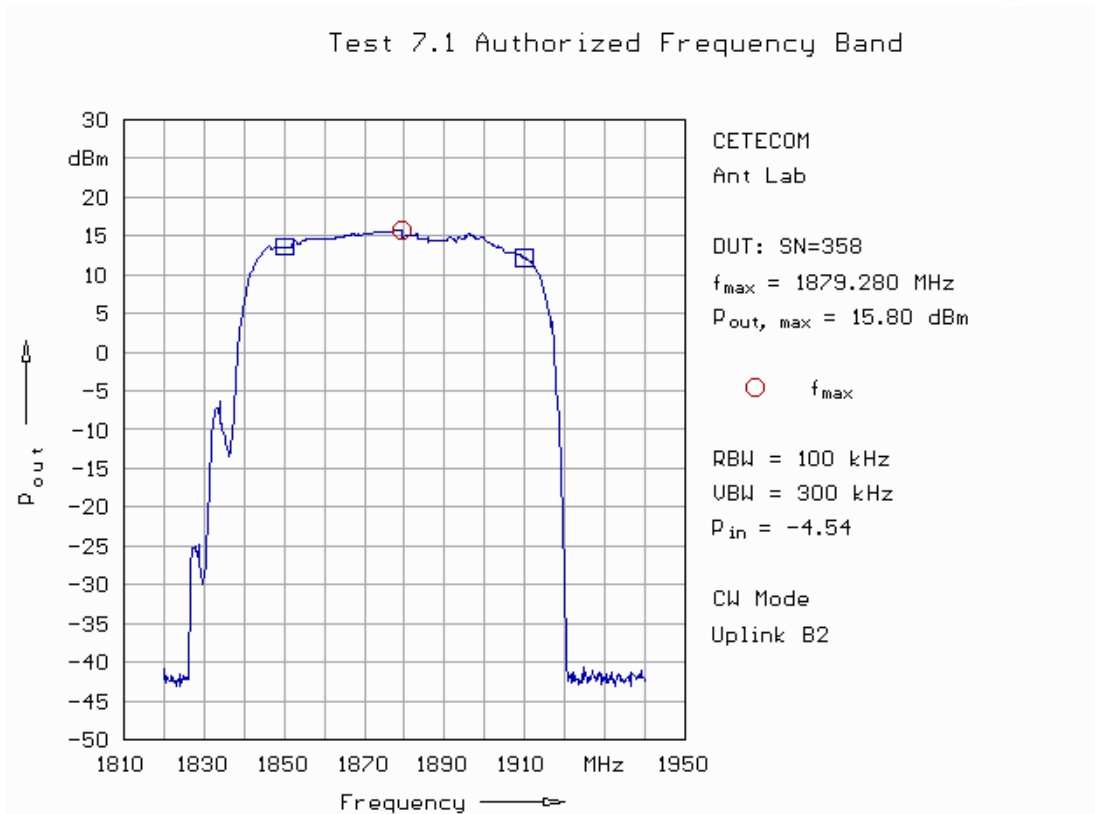

Fig. 3: Frequency response in uplink in band 2.

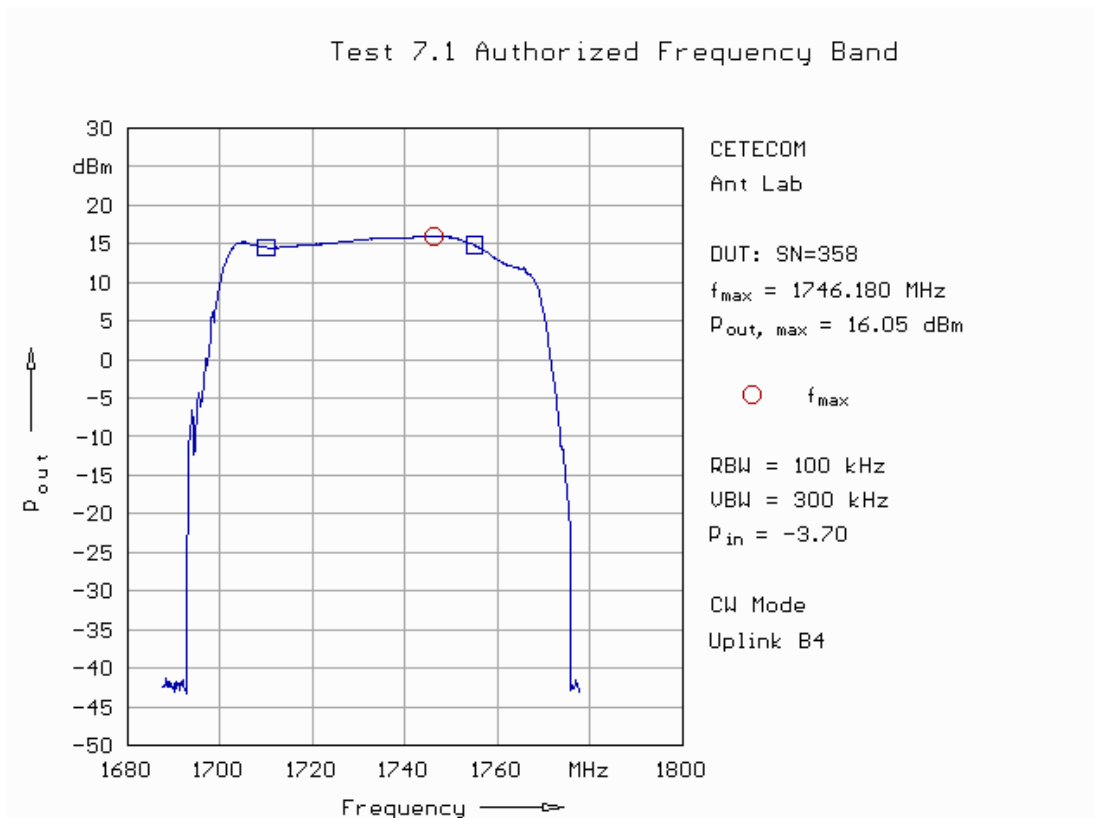

Fig. 4: Frequency response in uplink in band 4.

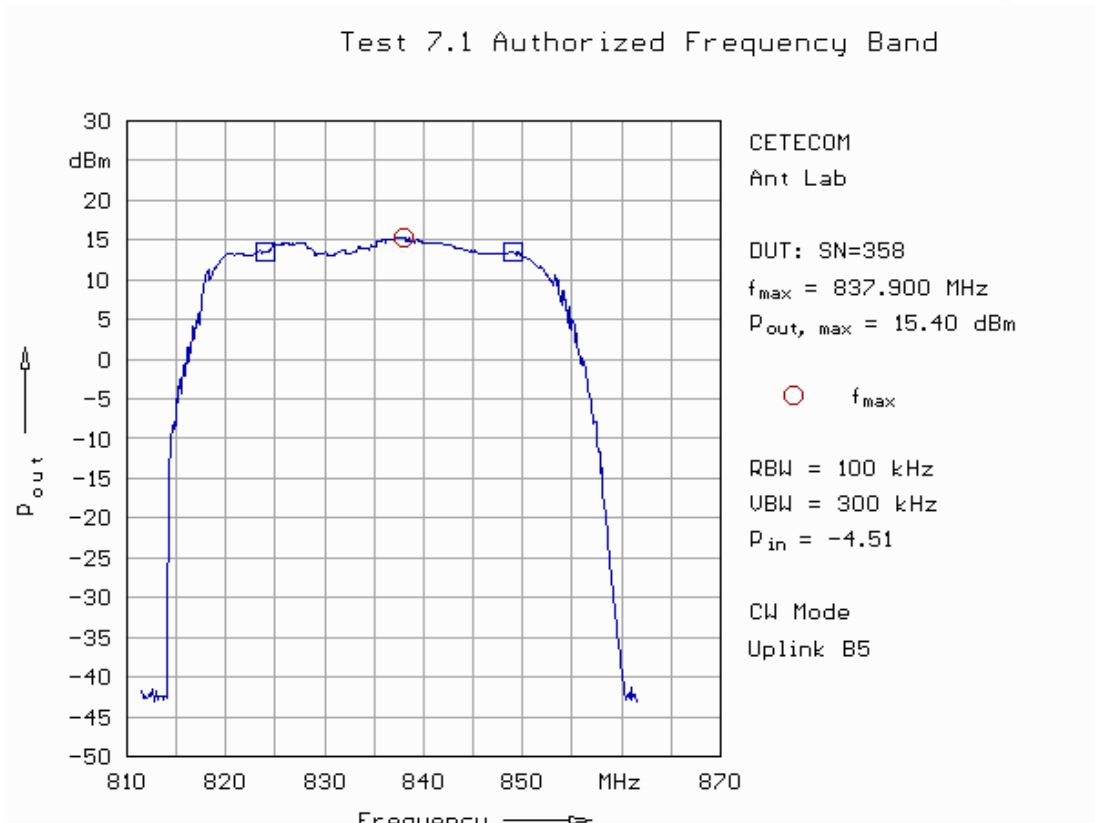

Fig. 5: Frequency response in uplink in band 5.

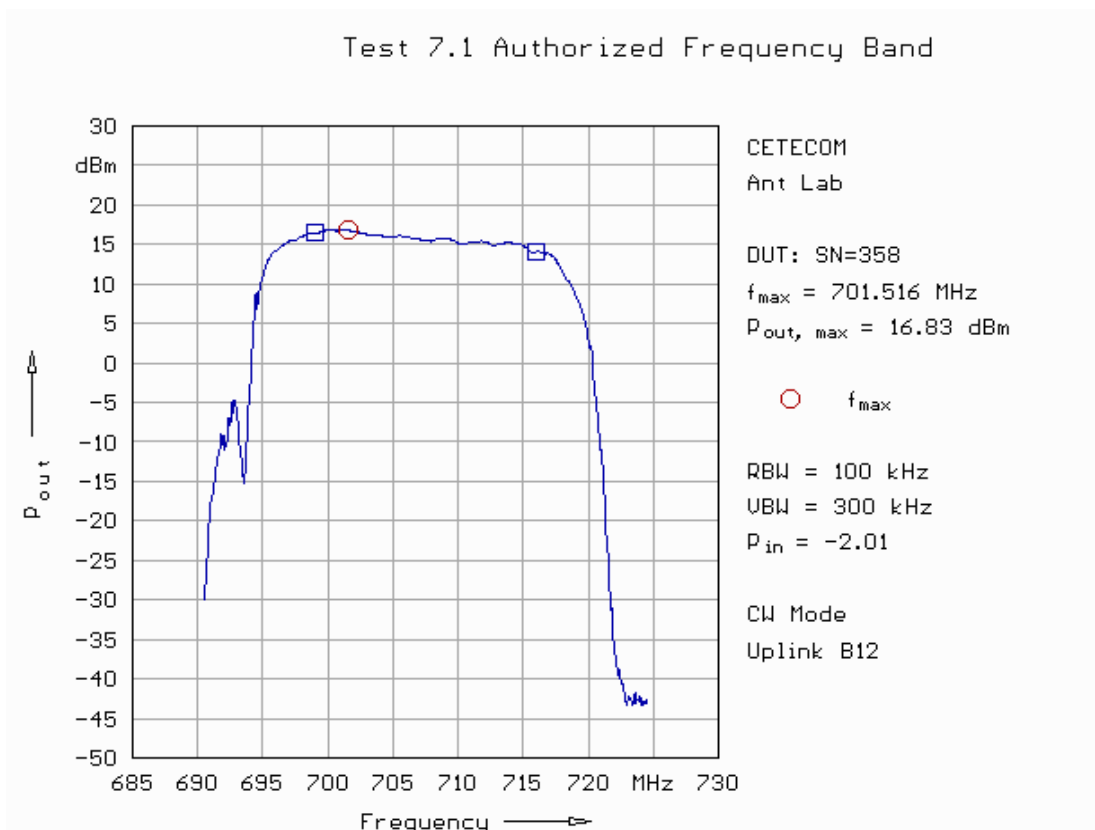

Fig. 6: Frequency response in uplink in band 12.

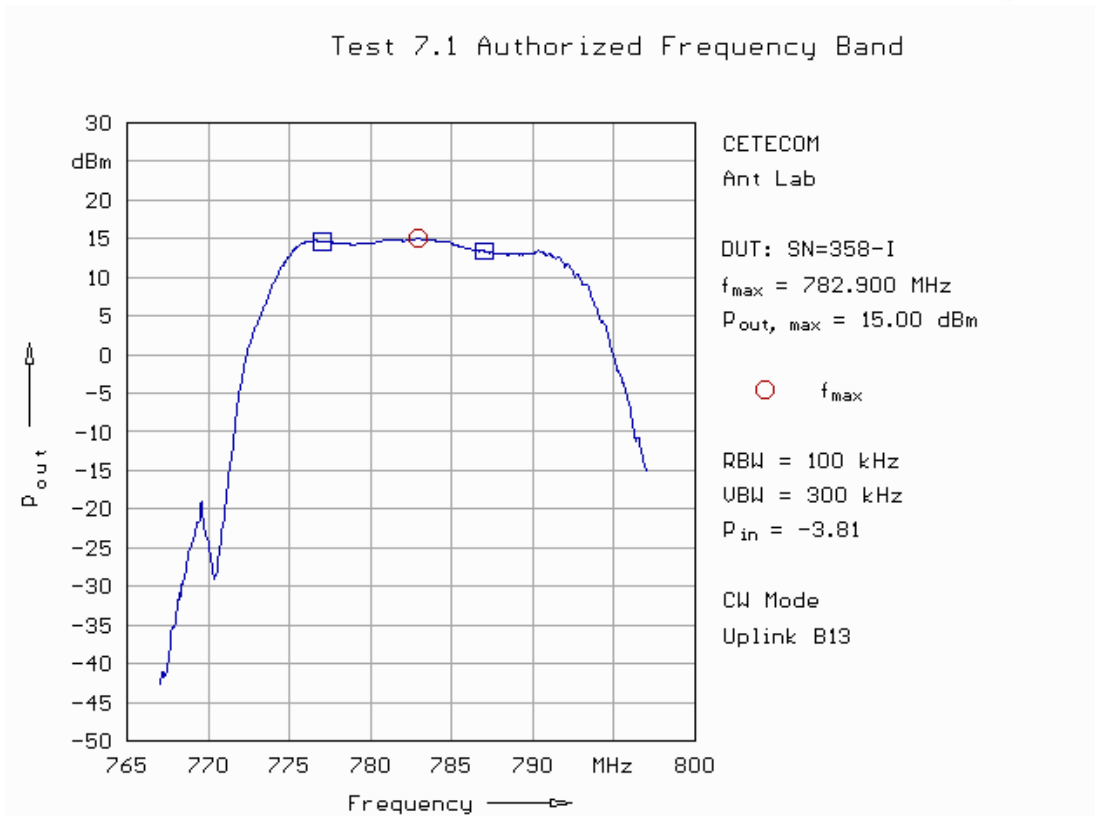

Fig. 7: Frequency response in uplink in band 13.

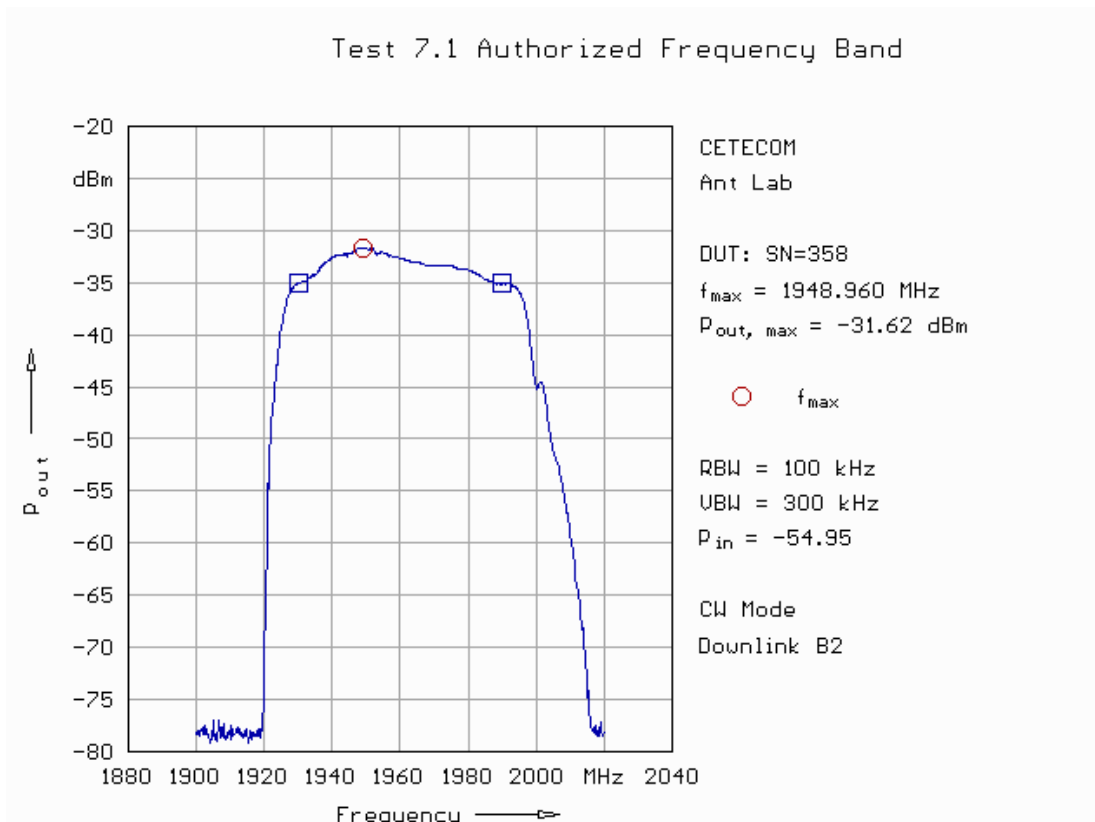

Fig. 8: Frequency response in downlink in band 2.

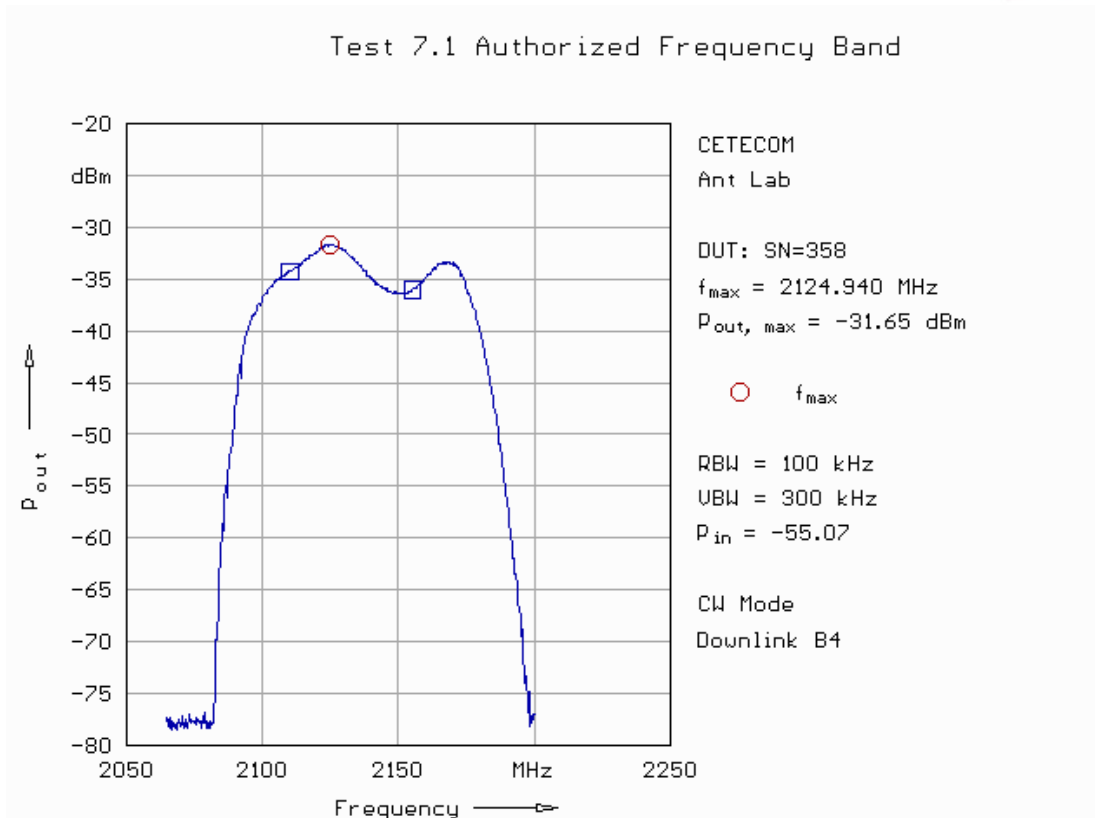

Fig. 9: Frequency response in downlink in band 4.

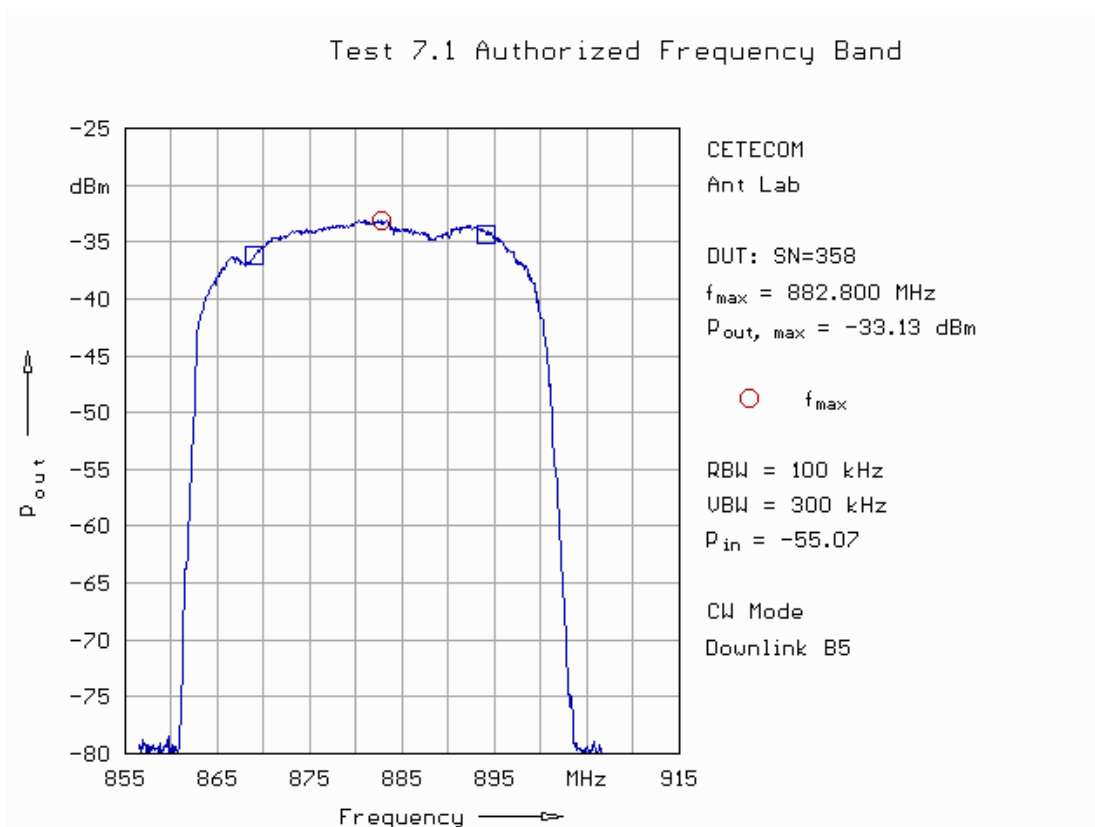

Fig. 10: Frequency response in downlink in band 5.

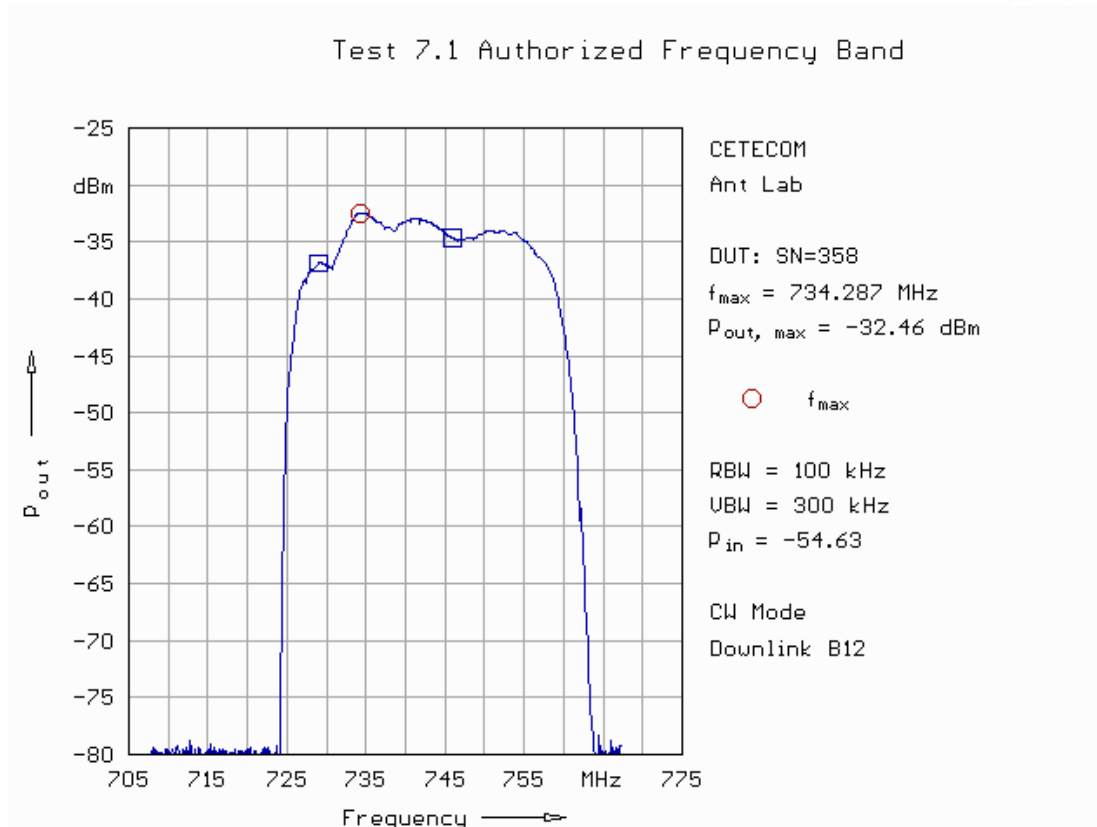

Fig. 11: Frequency response in downlink in band 12.

Note: In downlink band 12 and 13 are directly adjacent.

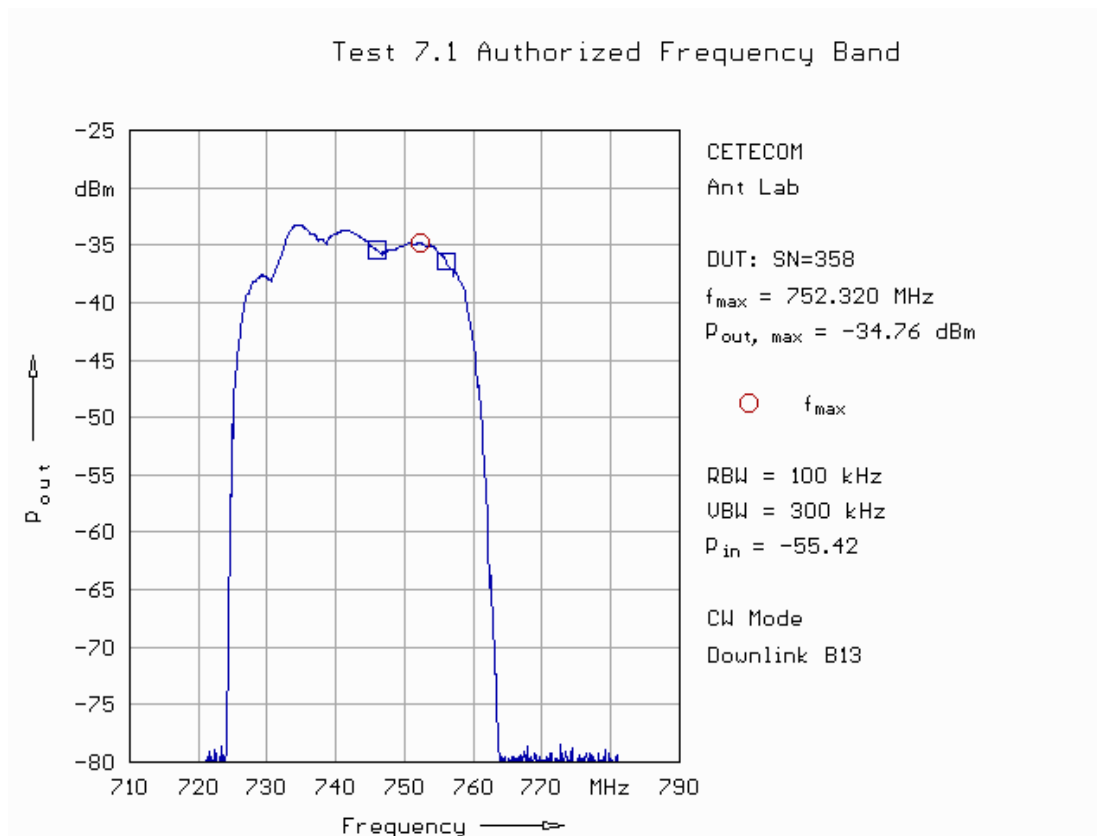

Fig. 12: Frequency response in downlink in band 13.

5.2. Maximum RF Power and Determination of AGC Start Level

The activated cable routing for this test in downlink has been the same as used in chapter 5.1. The activated cable routing for this test in uplink is shown in Fig. 13. Below are summarized the measured results for the P_{in} and P_{out} found just before the AGC starts, plus the absolute overall maximum output power found in uplink for 21.1 dB plus the maximum power found in downlink for -28.4 dBm.

All measured conducted RF power levels found are between +17 dBm and +30 dBm in uplink and well below +17 dBm in downlink.

Band	Direction	p_{in} at AGC start GSM	p_{out} at AGC start GSM	p_{out} Max. GSM	p_{in} at AGC start 4 MHz Signal	p_{out} at AGC start 4 MHz Signal	p_{out} Max 4 MHz Signal
2	up	-0.3 dBm	19.5 dBm	19.9 dBm	-1.6 dBm	17.7 dBm	18.2 dBm
4	up	0.2 dBm	19.9 dBm	20.4 dBm	-1.1 dBm	18.1 dBm	18.6 dBm
5	up	-0.5 dBm	19.5 dBm	19.9 dBm	-1.9 dBm	17.5 dBm	18.0 dBm
12	up	1.1 dBm	20.7 dBm	21.1 dBm	-0.3 dBm	18.7 dBm	19.2 dBm
13	up	-0.05 dBm	19.4 dBm	19.8 dBm	-1.0 dBm	17.5 dBm	18.0 dBm
2	down	-51.8 dBm	-31.7 dBm	-28.4 dBm	-51.1 dBm	-30.9 dBm	-28.5 dBm
4	down	-52.3 dBm	-32.0 dBm	-28.6 dBm	-51.2 dBm	-31.2 dBm	-29.0 dBm
5	down	-52.0 dBm	-33.1 dBm	-29.8 dBm	-51.4 dBm	-33.0 dBm	-30.2 dBm
12	down	-51.0 dBm	-32.0 dBm	-29.1 dBm	-50.8 dBm	-31.9 dBm	-29.8 dBm
13	down	-50.8 dBm	-33.4 dBm	-30.4 dBm	-50.9 dBm	-33.2 dBm	-30.9 dBm

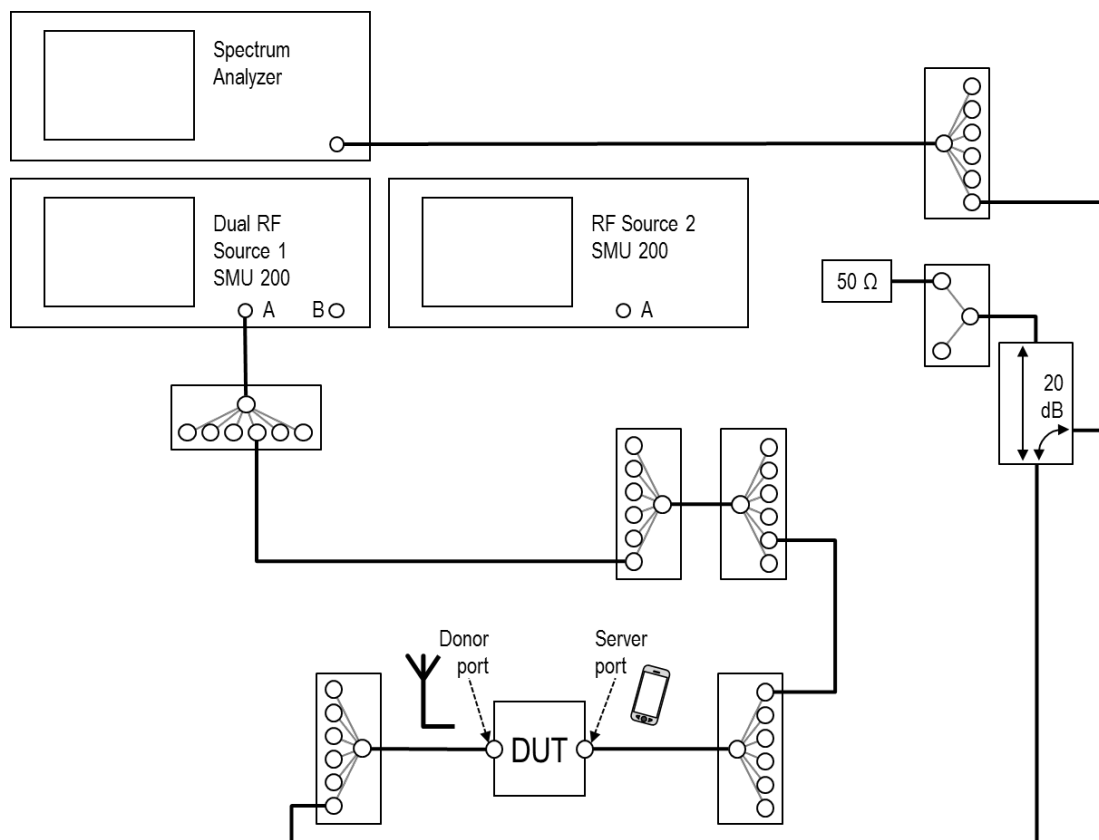

Fig. 13: Set up for maximum RF power test in uplink.

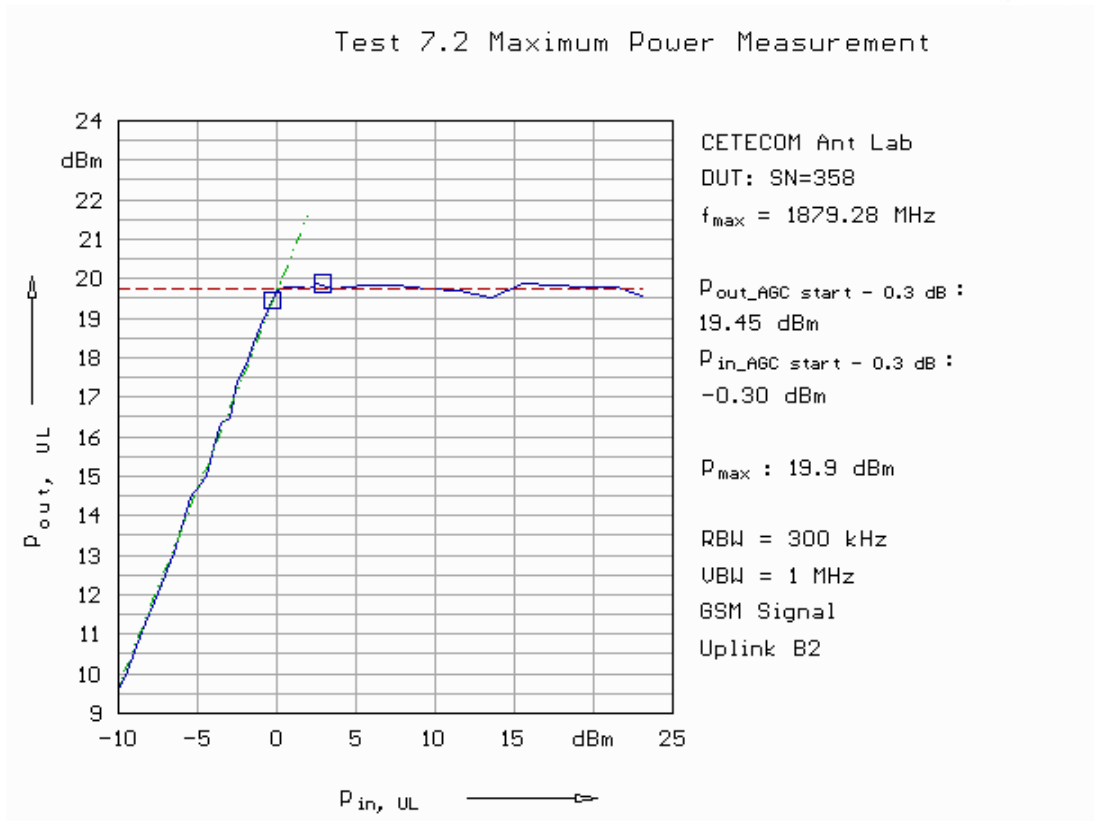

Fig. 14: Power measurement in uplink in band 2 applying a GSM signal.

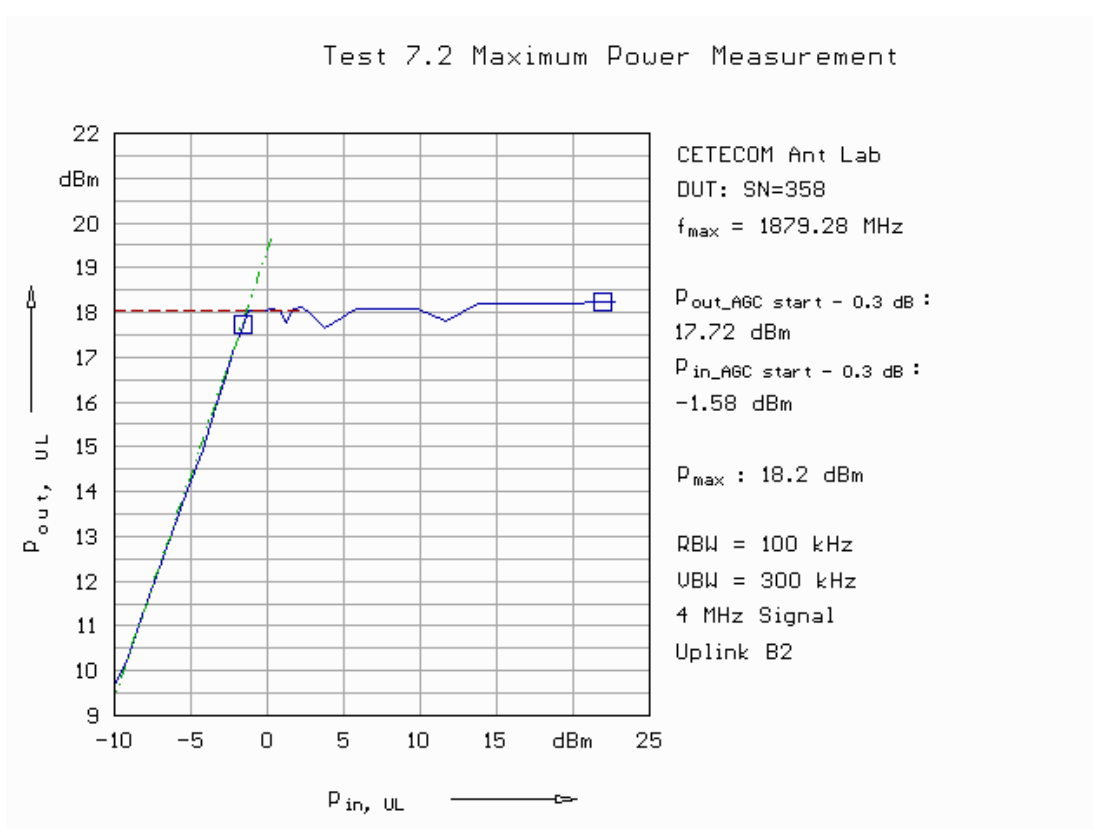

Fig. 15: Power measurement in uplink in band 2 applying a 4 MHz signal.

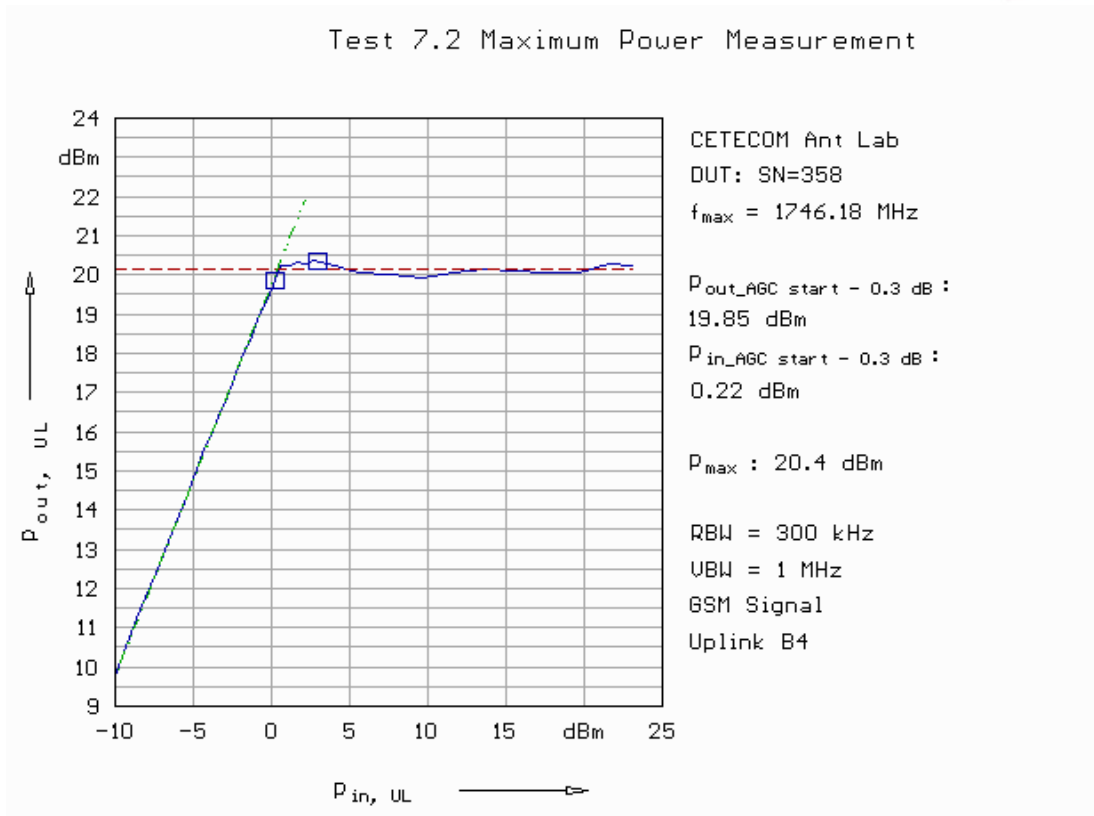

Fig. 16: Power measurement in uplink in band 4 applying a GSM signal.

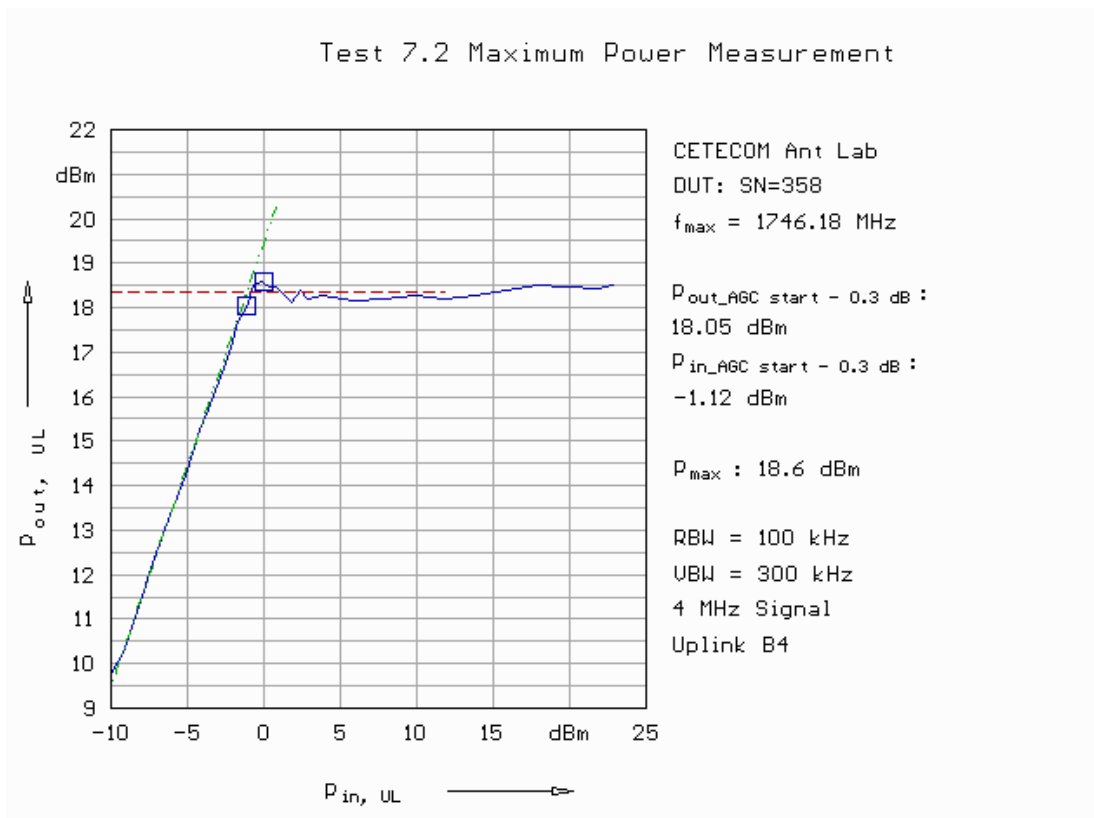

Fig. 17: Power measurement in uplink in band 4 applying a 4 MHz signal.

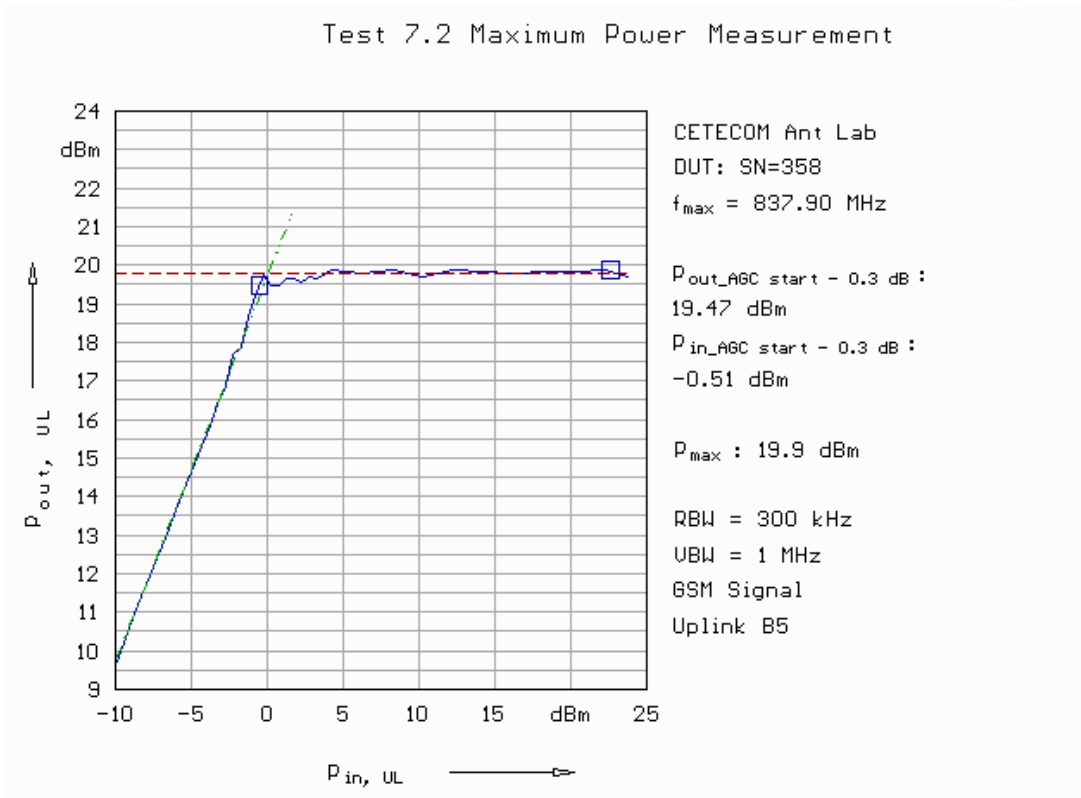

Fig. 18: Power measurement in uplink in band 5 applying a GSM signal.

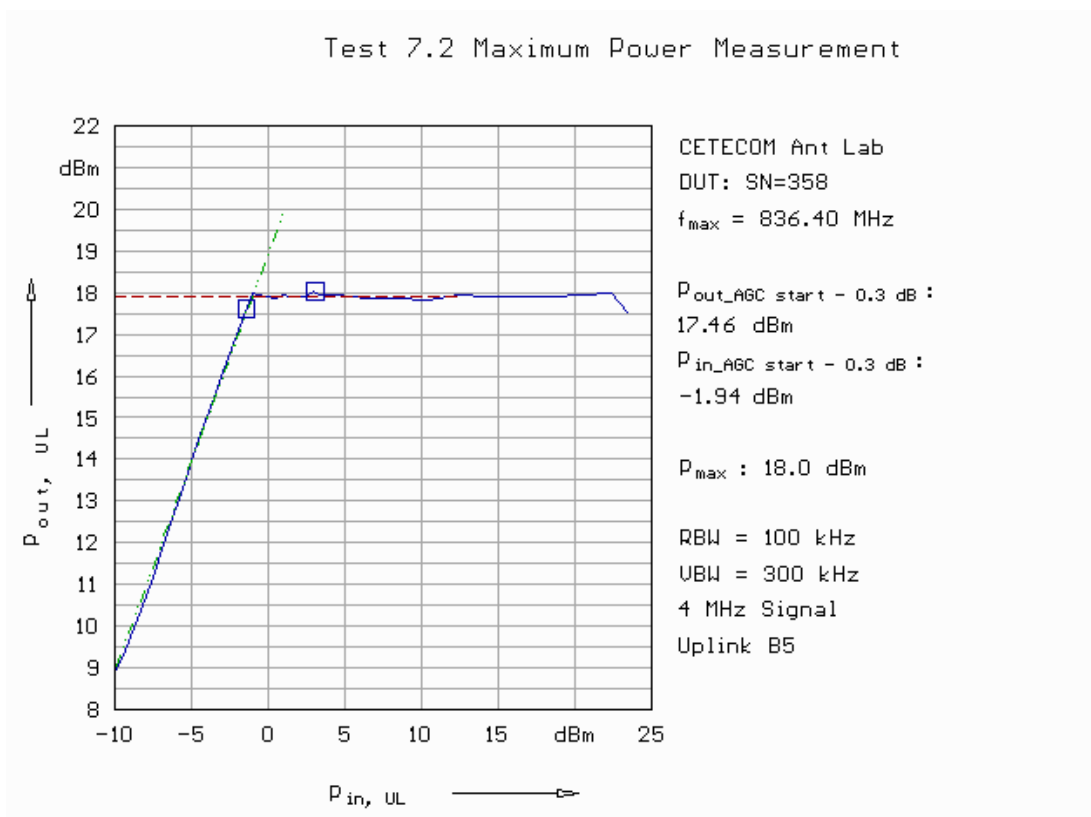

Fig. 19: Power measurement in uplink in band 5 applying a 4 MHz signal.

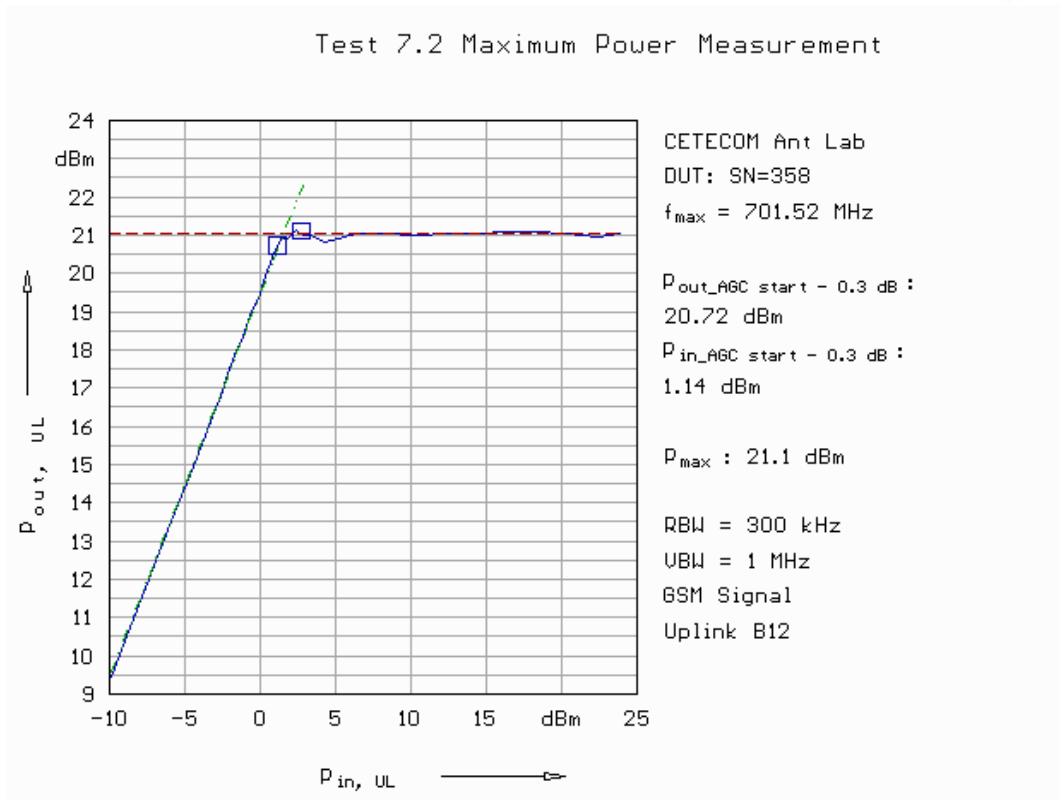

Fig. 20: Power measurement in uplink in band 12 applying a GSM signal.

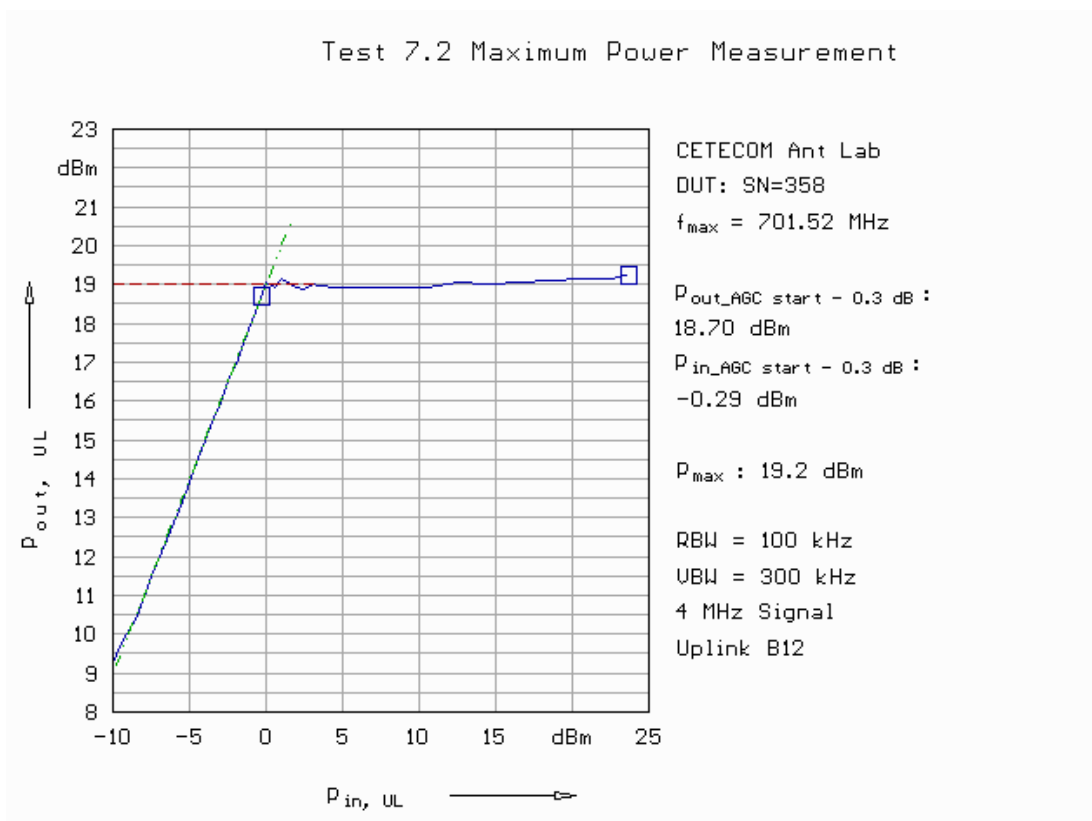

Fig. 21: Power measurement in uplink in band 12 applying a 4 MHz signal.

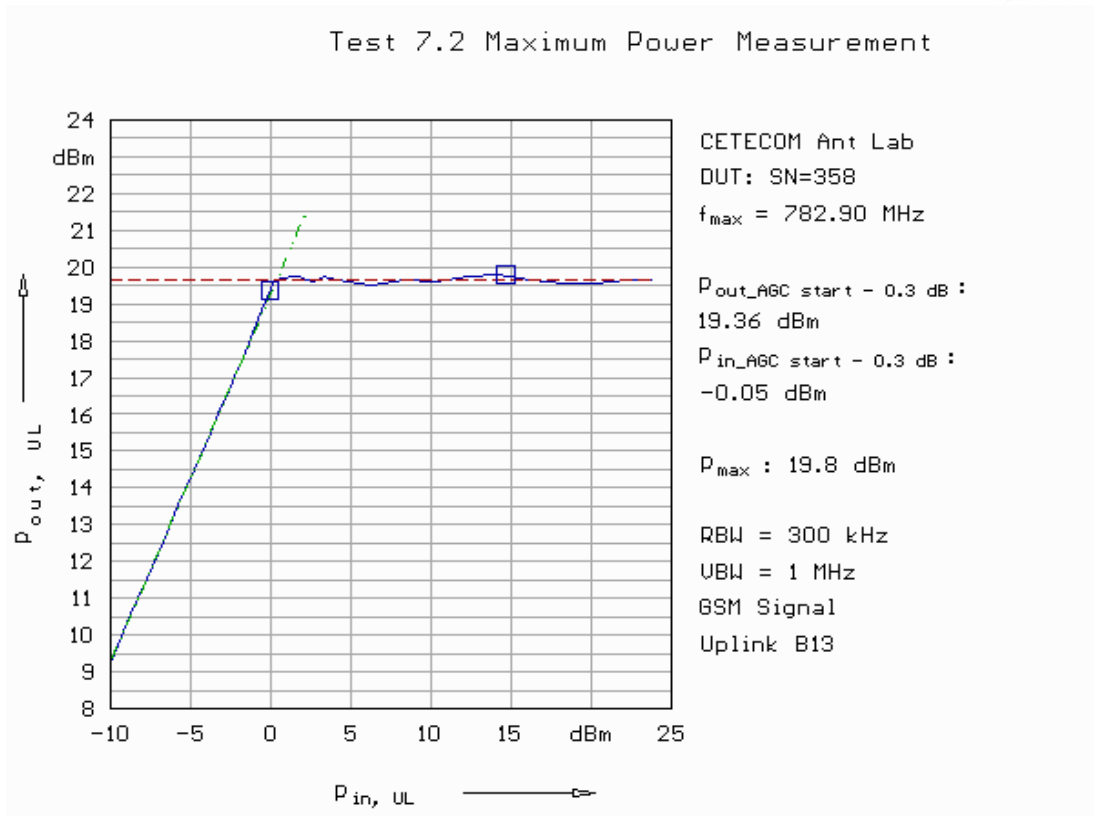

Fig. 22: Power measurement in uplink in band 13 applying a GSM signal.

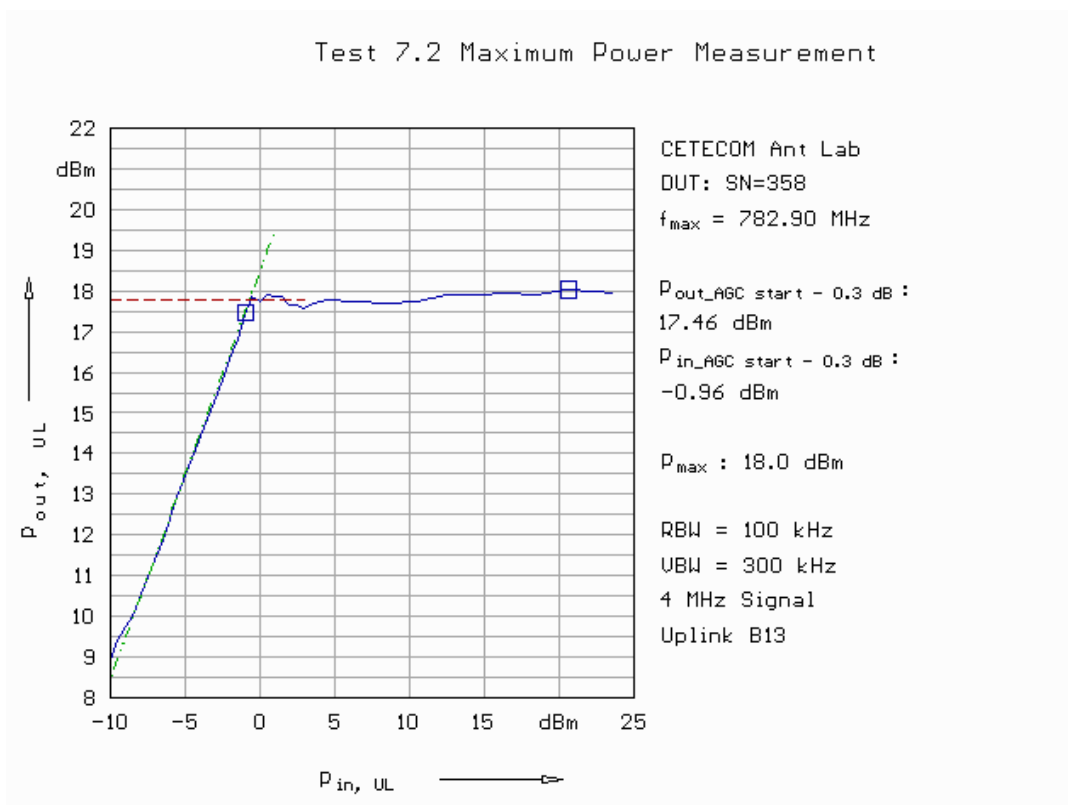

Fig. 23: Power measurement in uplink in band 13 applying a 4 MHz signal.

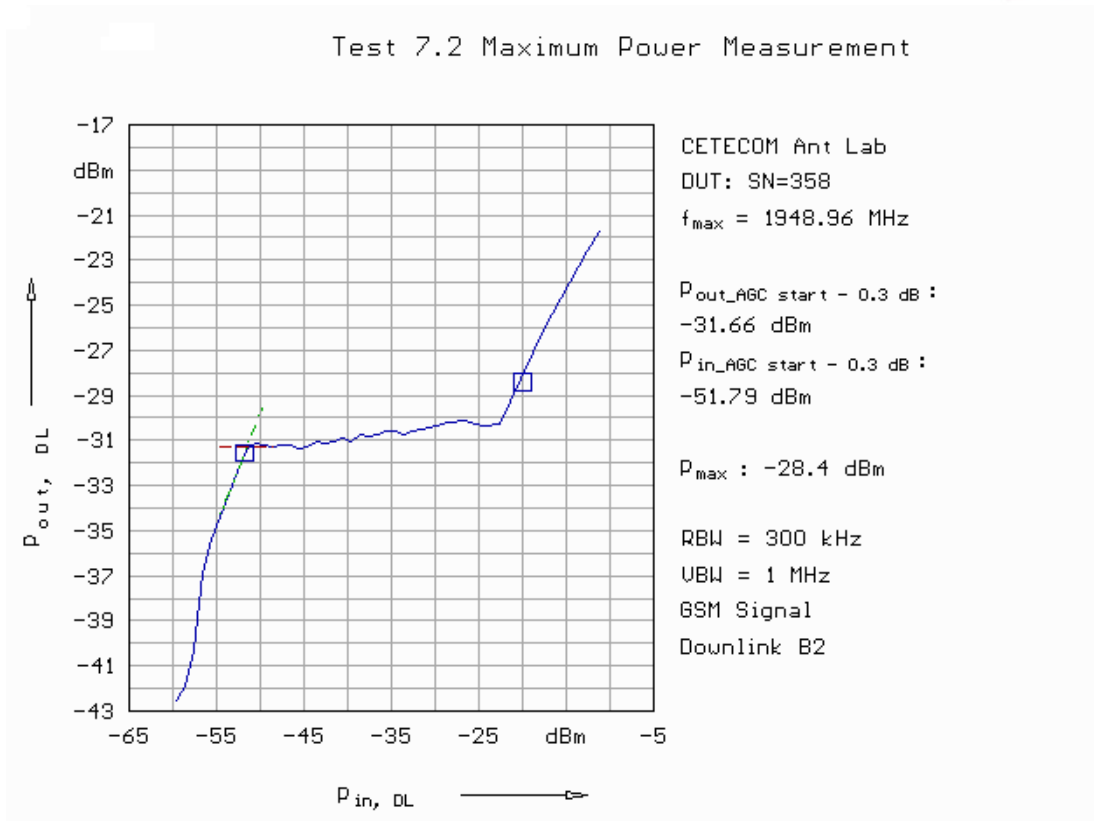

Fig. 24: Power measurement in downlink in band 2 applying a GSM signal.

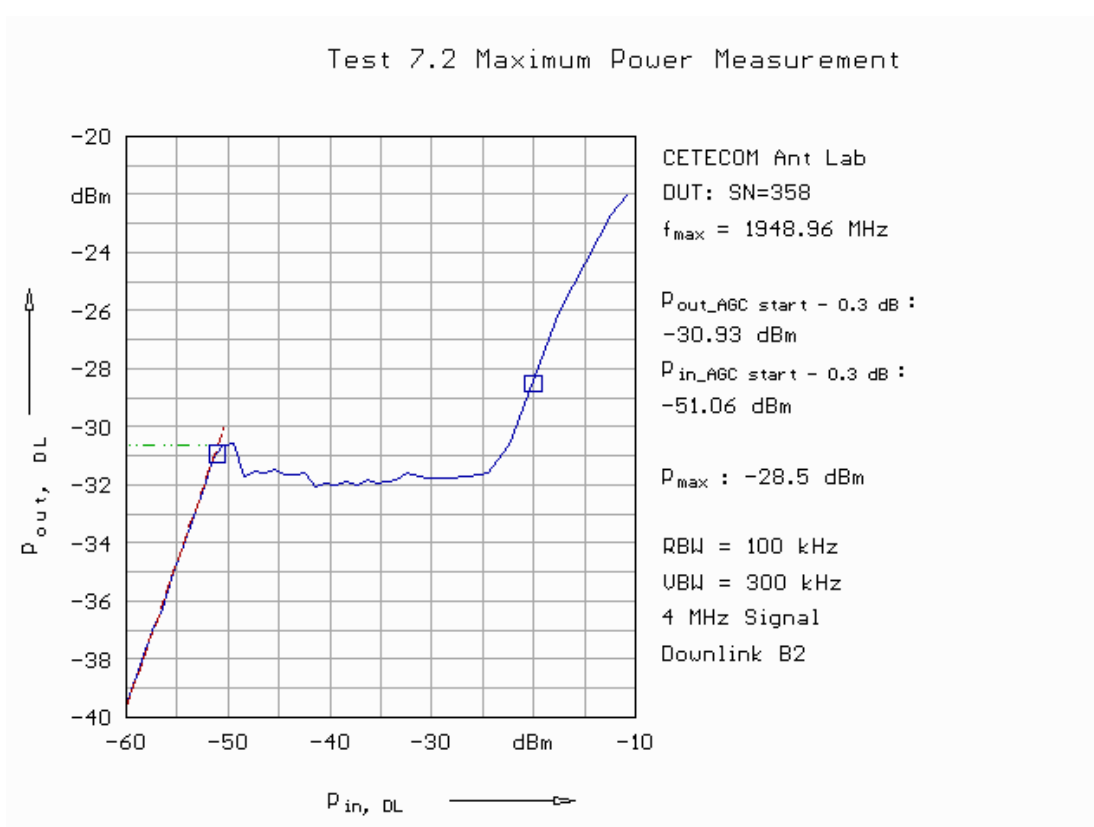

Fig. 25: Power measurement in downlink in band 2 applying a 4 MHz signal.

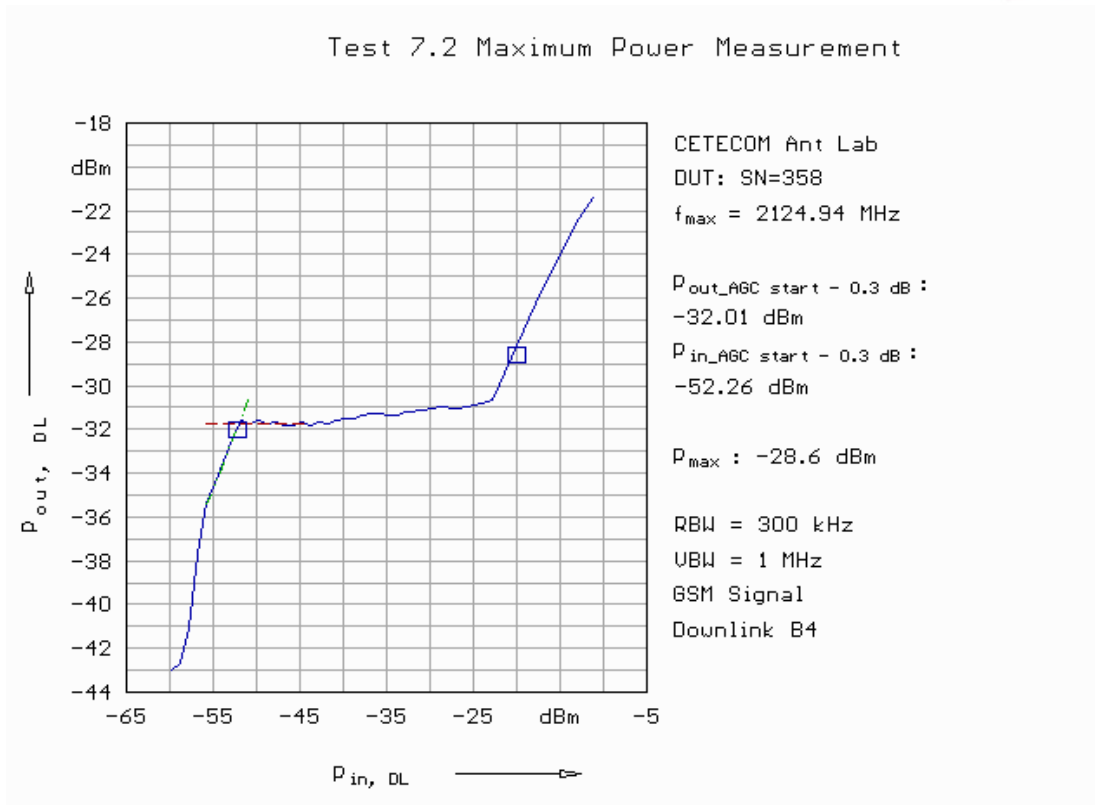

Fig. 26: Power measurement in downlink in band 4 applying a GSM signal.

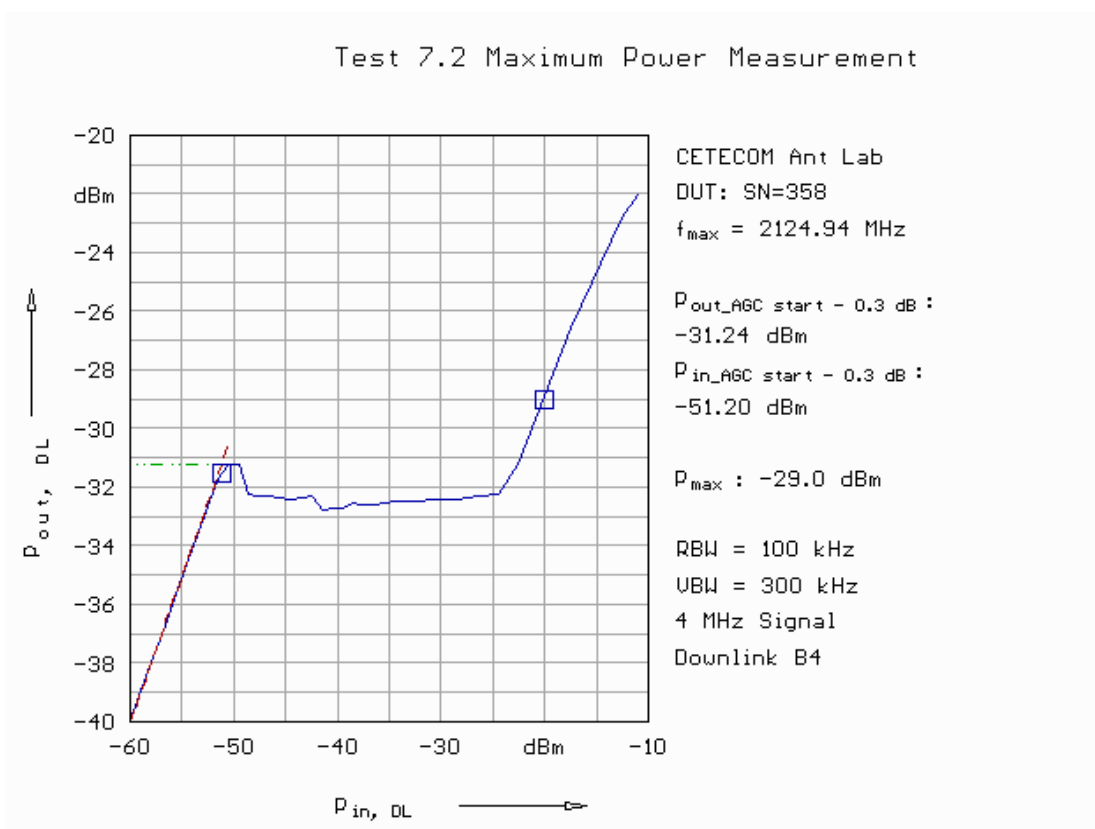

Fig. 27: Power measurement in downlink in band 4 applying a 4 MHz signal.

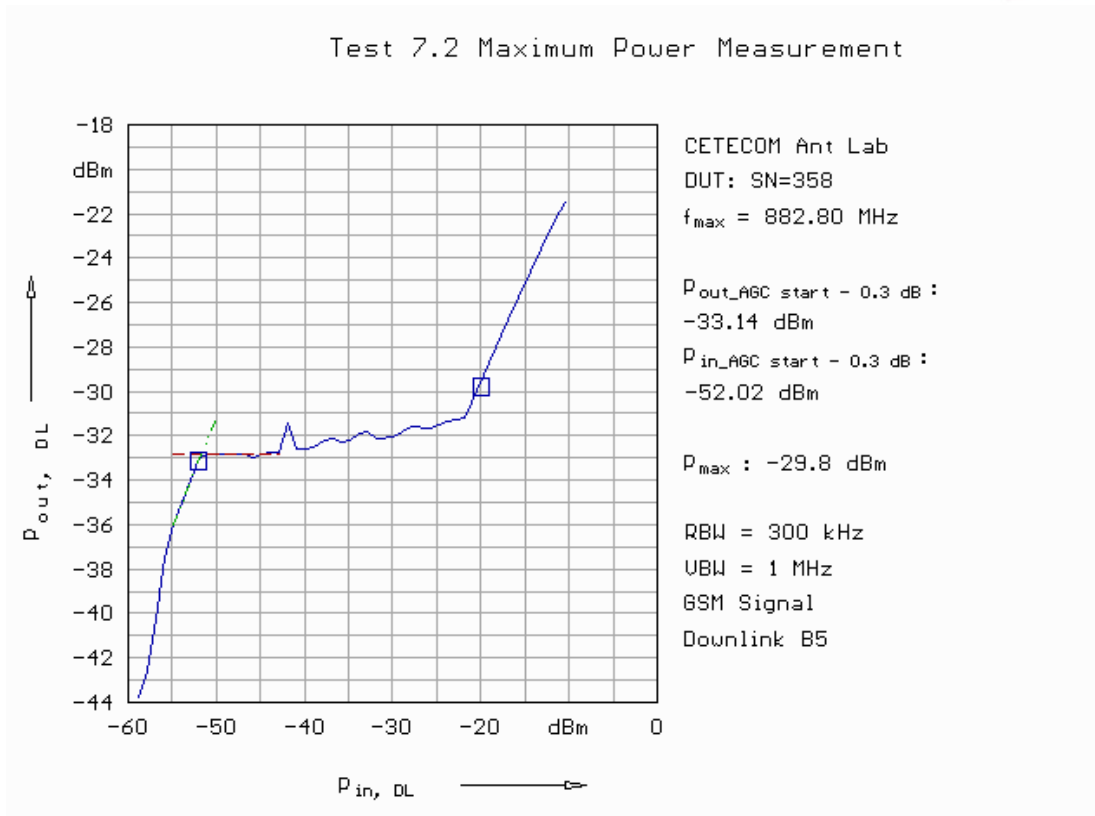

Fig. 28: Power measurement in downlink in band 5 applying a GSM signal.

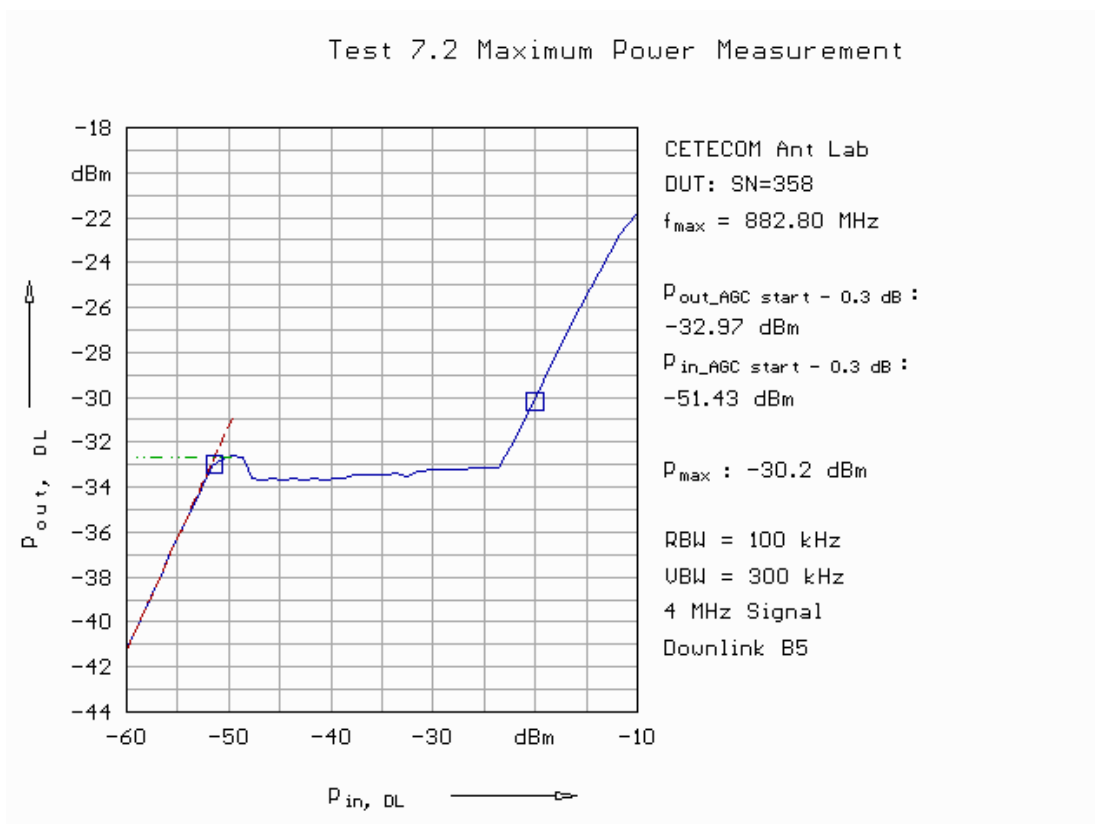

Fig. 29: Power measurement in downlink in band 5 applying a 4 MHz signal.

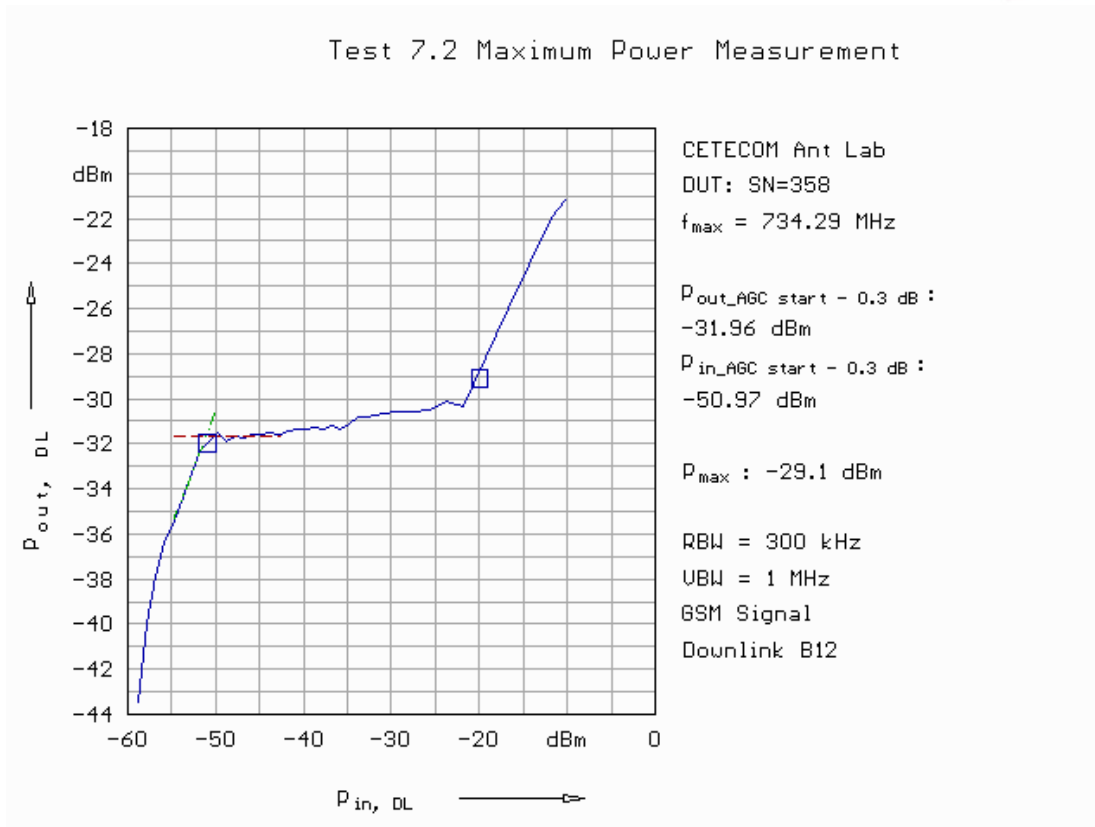

Fig. 30: Power measurement in downlink in band 12 applying a GSM signal.

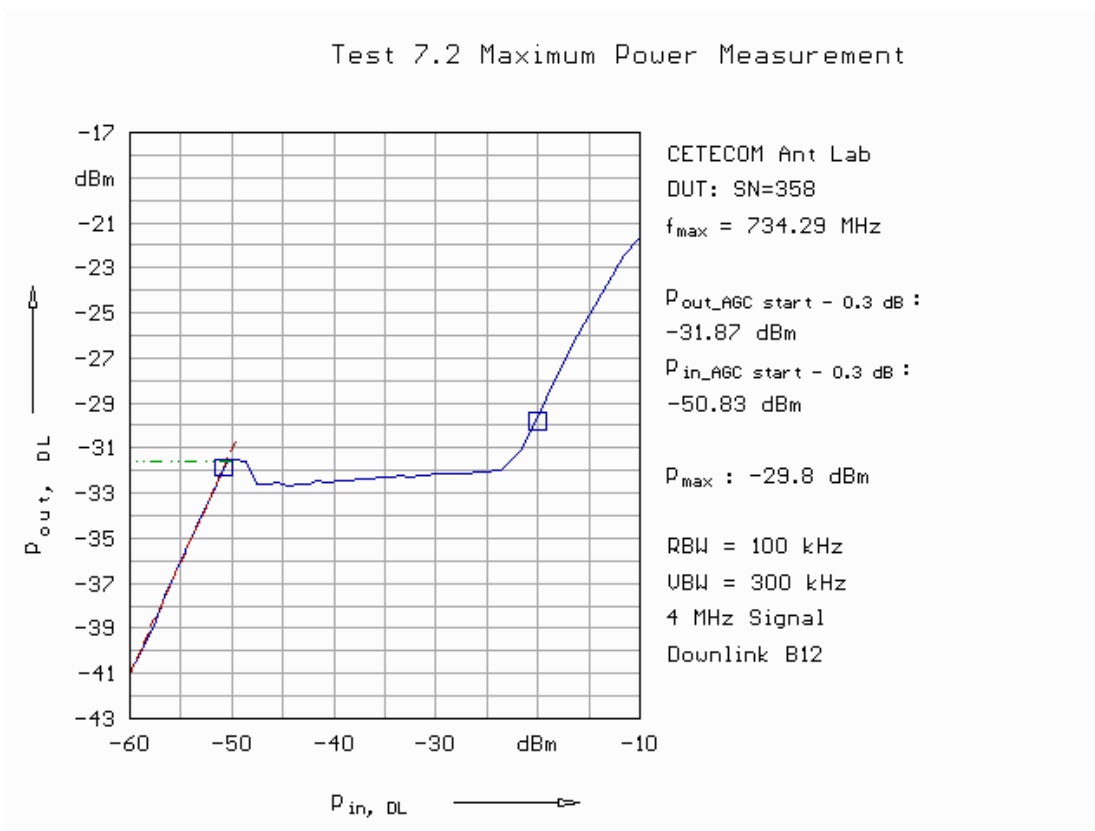

Fig. 31: Power measurement in downlink in band 12 applying a 4 MHz signal.

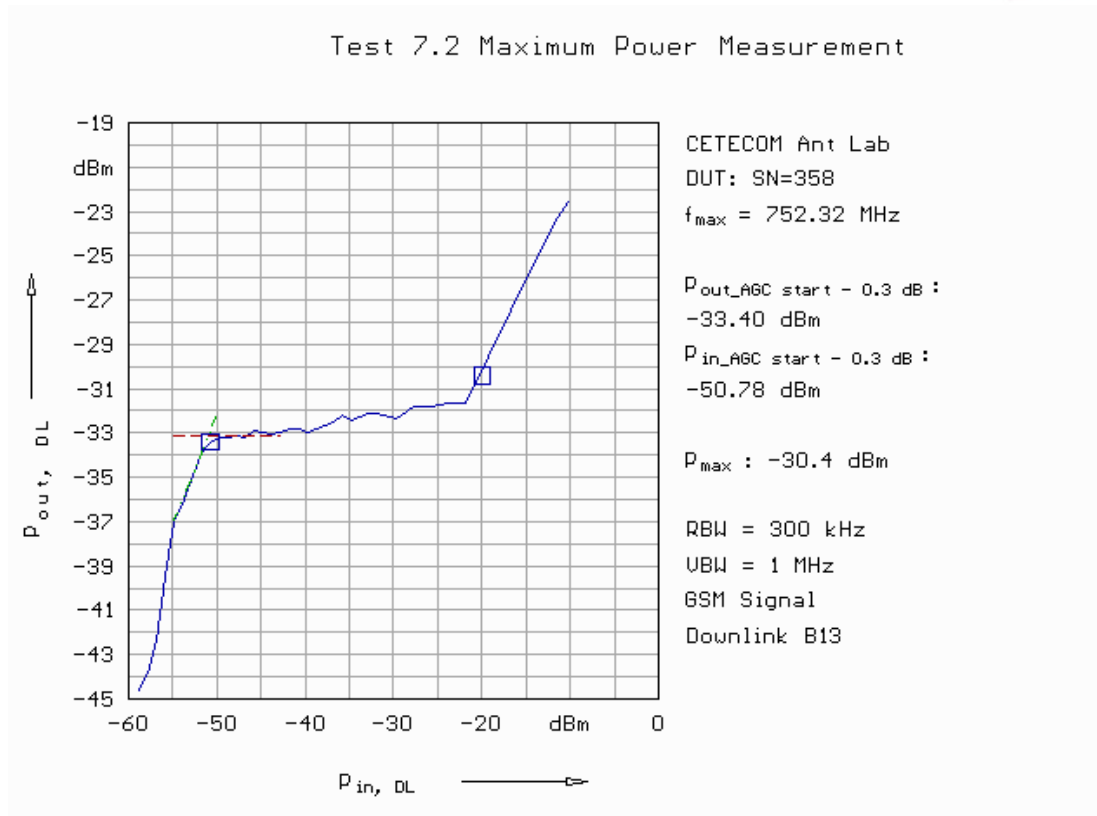

Fig. 32: Power measurement in downlink in band 13 applying a GSM signal.

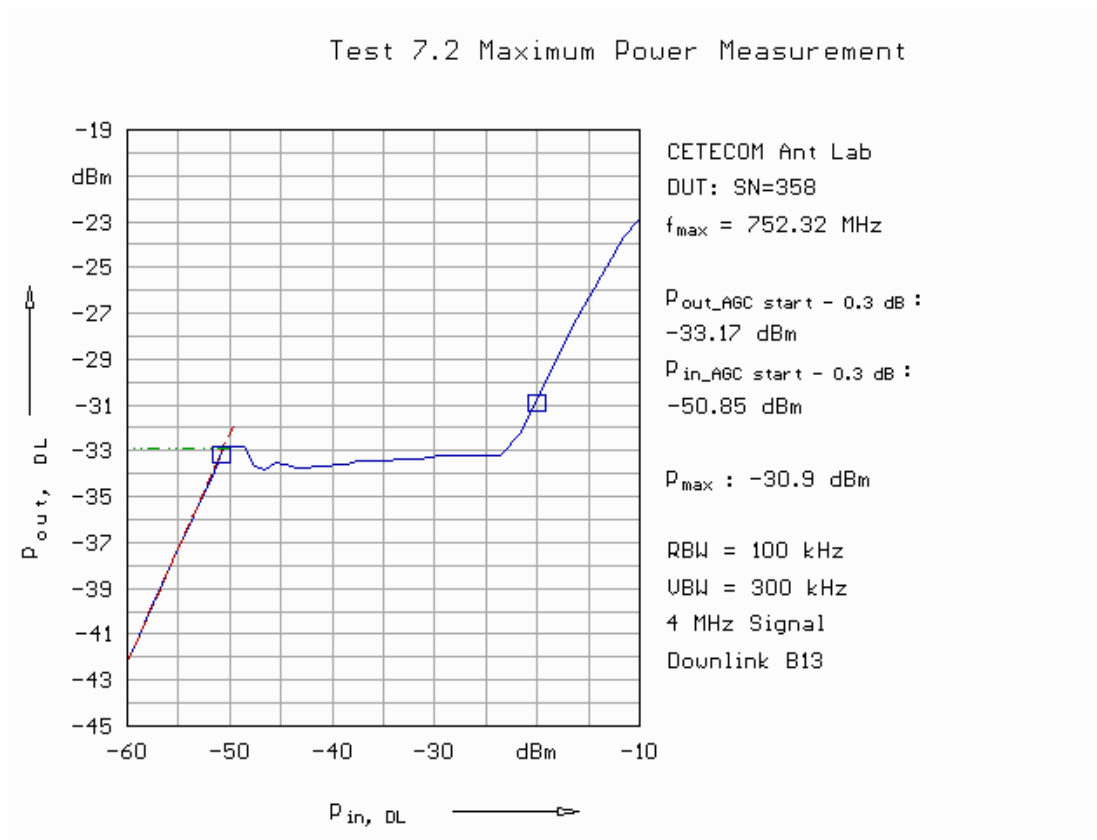

Fig. 33: Power measurement in downlink in band 13 applying a 4 MHz signal.

5.3. Gain

Measured data as shown in chapter 5.2 has been used to calculate up- and downlink gain values. The results are summarized below.

Band	Gain uplink GSM mode	Gain uplink 4 MHz Signal mode	Gain downlink GSM mode	Gain downlink 4 MHz Signal mode
2	19.8 dB	19.3 dB	20.1 dB	20.2 dB
4	19.7 dB	19.2 dB	20.3 dB	20.0 dB
5	20.0 dB	19.4 dB	18.9 dB	18.4 dB
12	19.6 dB	19.0 dB	19.0 dB	18.9 dB
13	19.4 dB	18.5 dB	17.4 dB	17.7 dB

All gain data do meet the limit of 23 dB (for cradle type of booster) and the maximum difference between up- and downlink is actually 1.1 dB and hence well below the 9 dB limit.

5.4. Intermodulation

The activated cable routing for this test in uplink is shown in Fig. 34 and for the downlink in Fig. 35, respectively. As illustrated on the next pages the EUT meets the limit of -19 dBm in all required conditions for intermodulation. (Just before the EUT begins AGC and 10 dB above the AGC threshold).

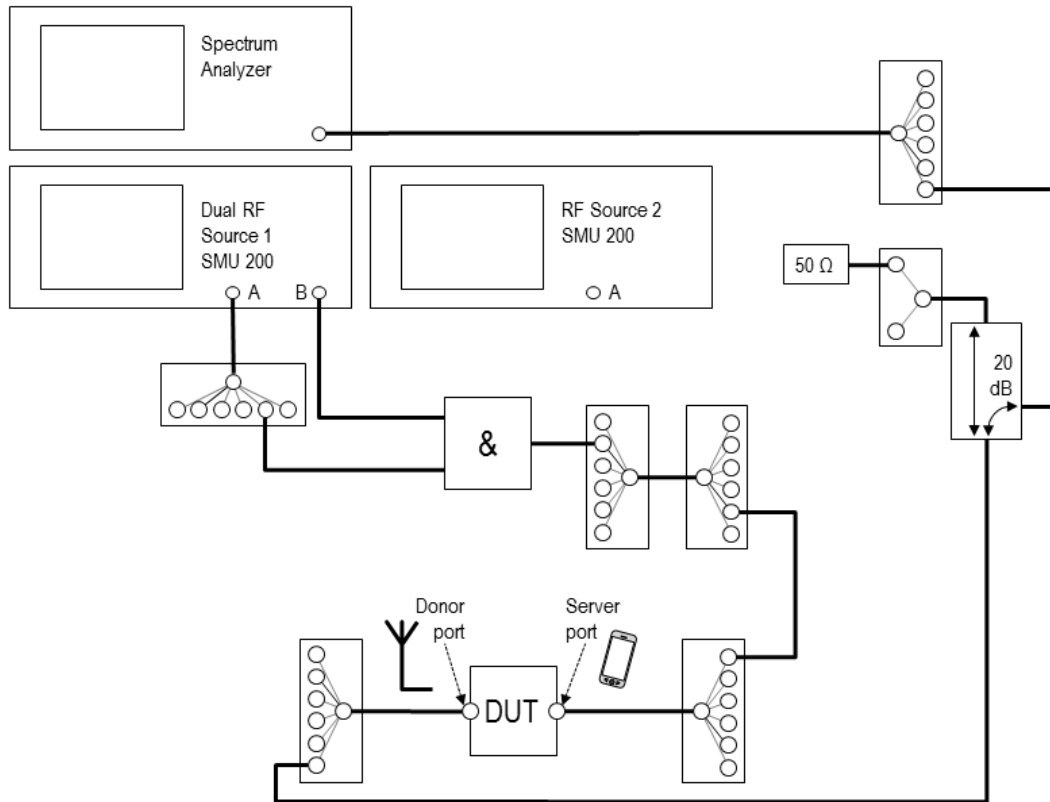

Fig. 34: Set up for intermodulation test in uplink.

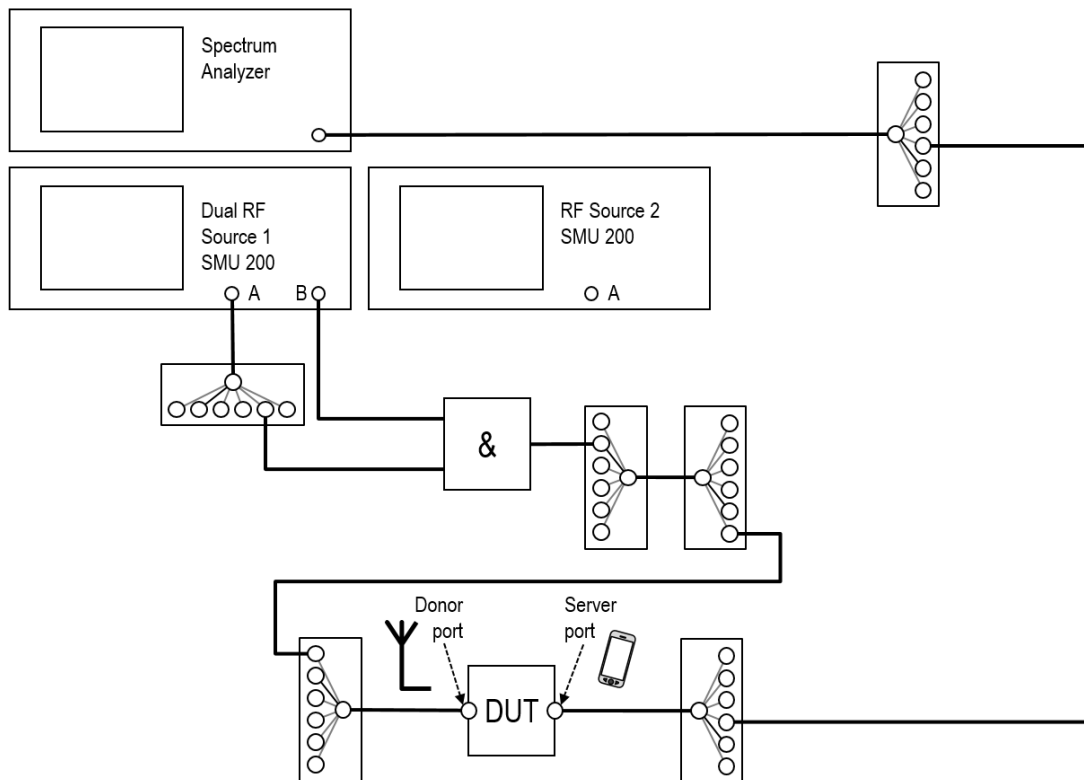

Fig. 35: Set up for intermodulation test in downlink.

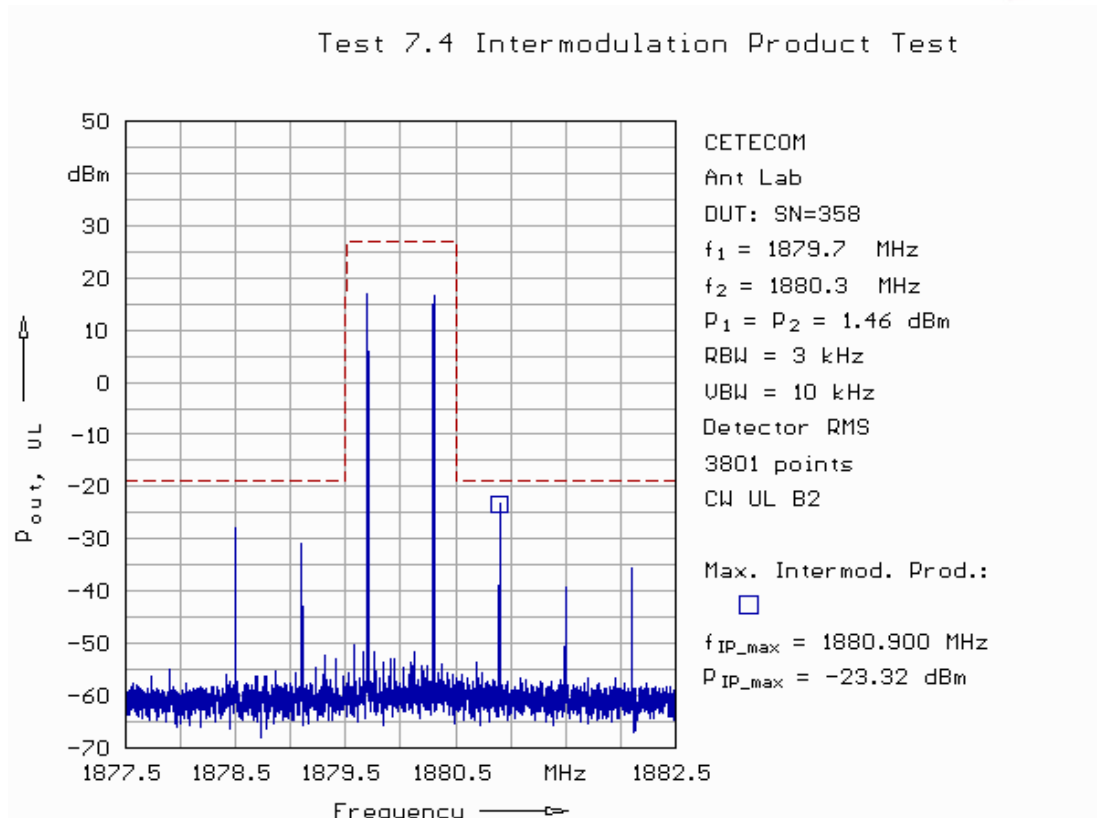

Fig. 36: Intermodulation test in uplink in band 2 at AGC.

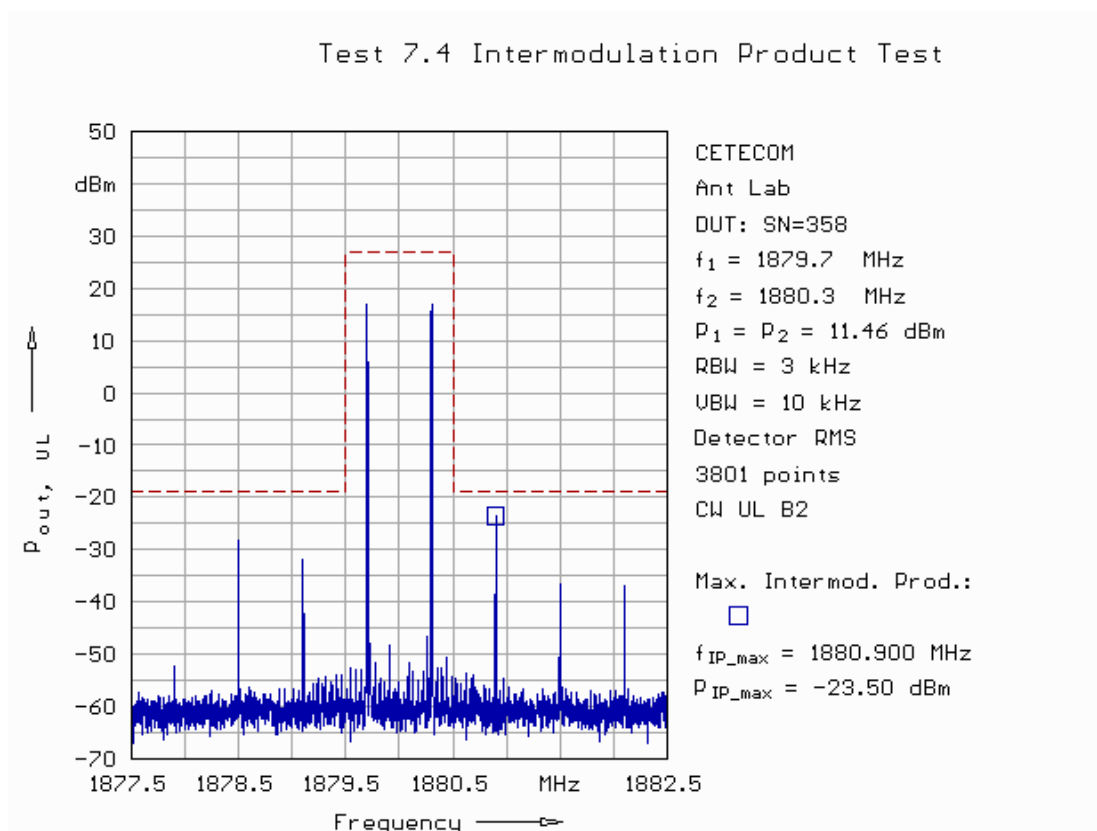

Fig. 37: Intermodulation test in uplink in band 2 at AGC plus 10 dB.

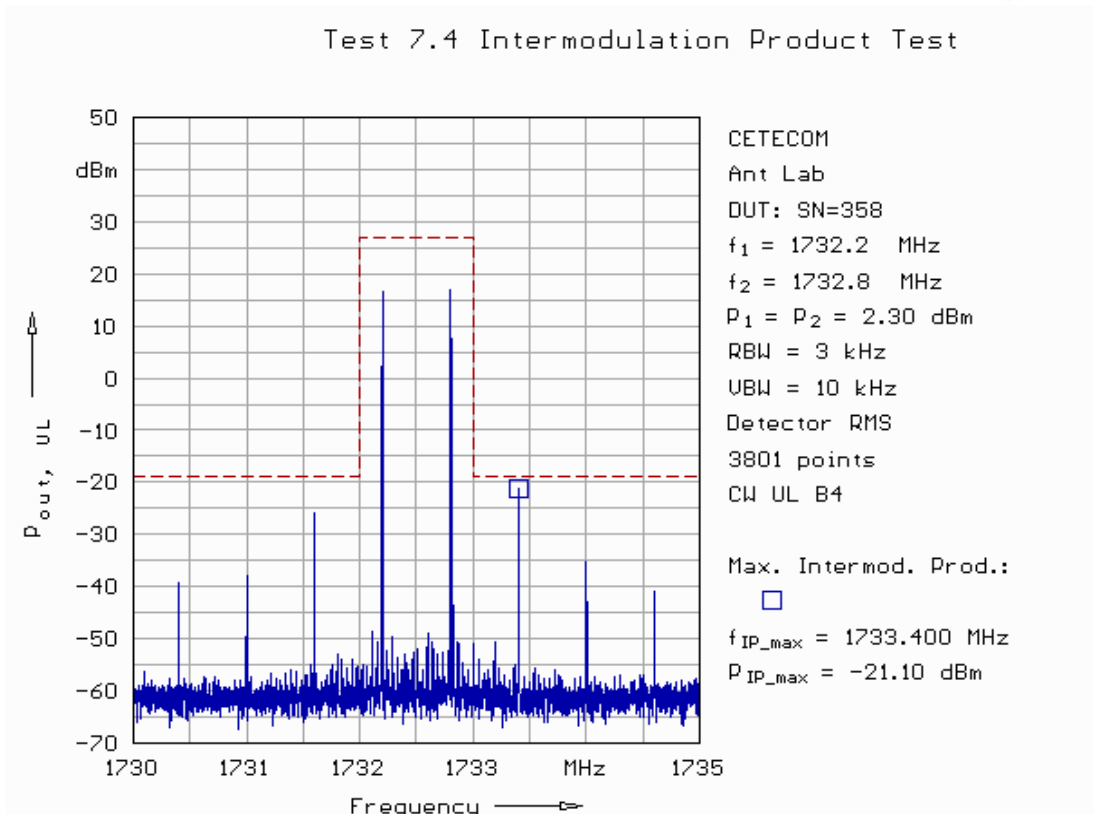

Fig. 38: Intermodulation test in uplink in band 4 at AGC.

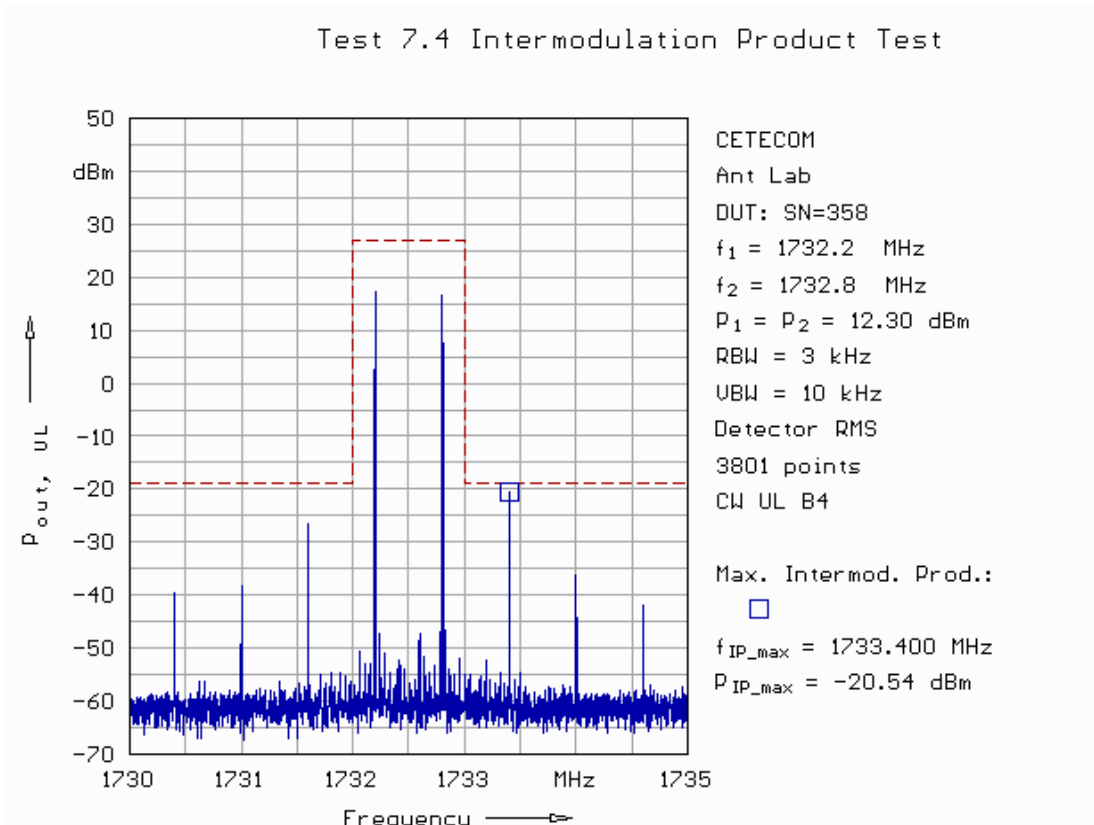

Fig. 39: Intermodulation test in uplink in band 4 at AGC plus 10 dB.

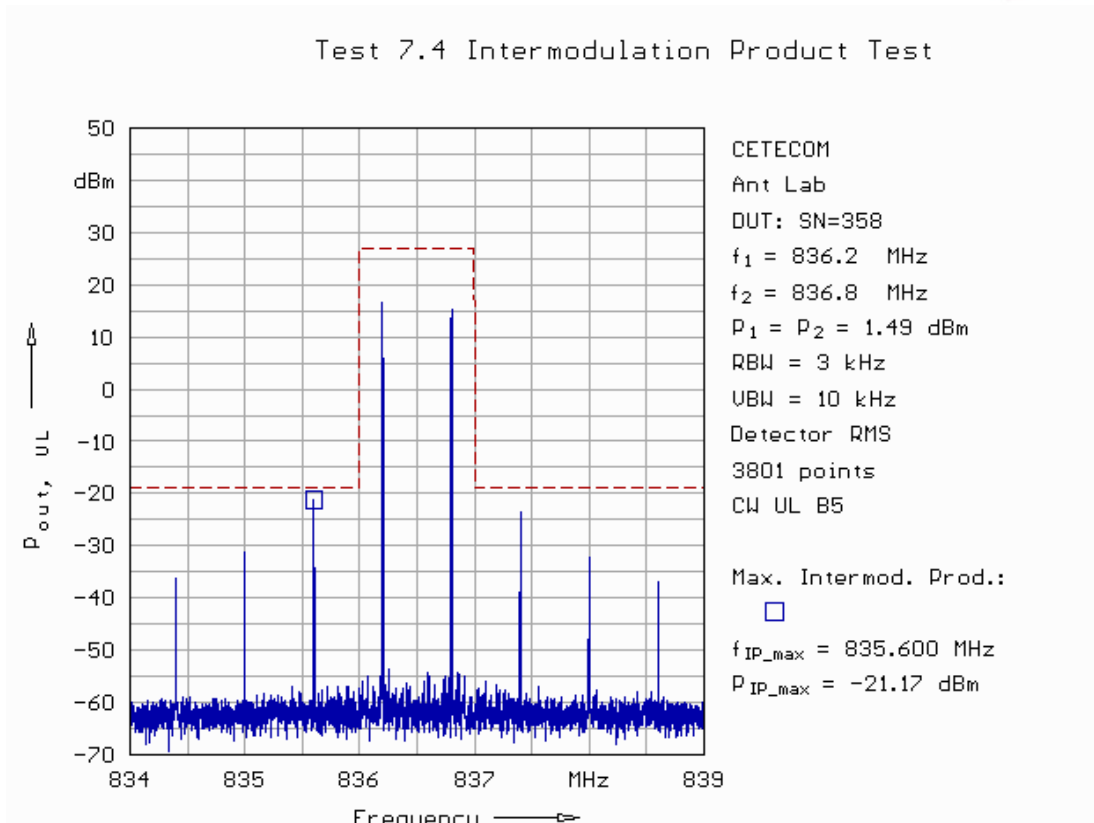

Fig. 40: Intermodulation test in uplink in band 5 at AGC.

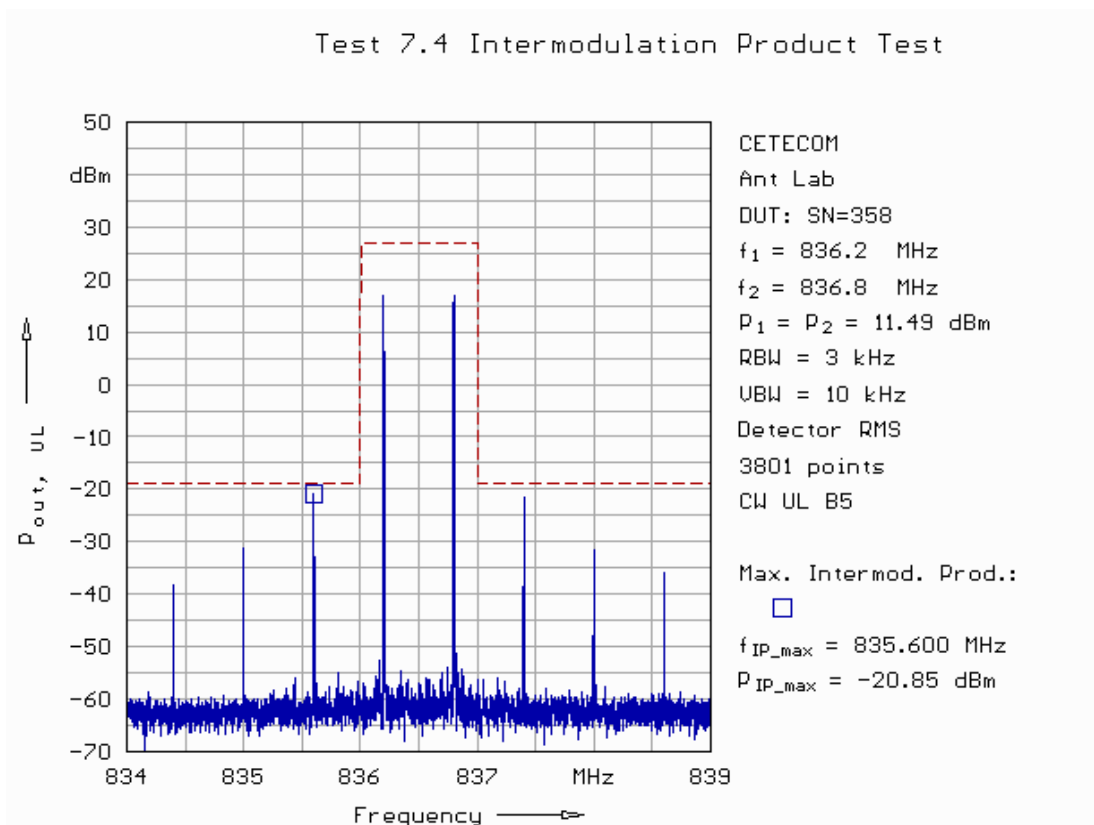

Fig. 41: Intermodulation test in uplink in band 5 at AGC plus 10 dB.

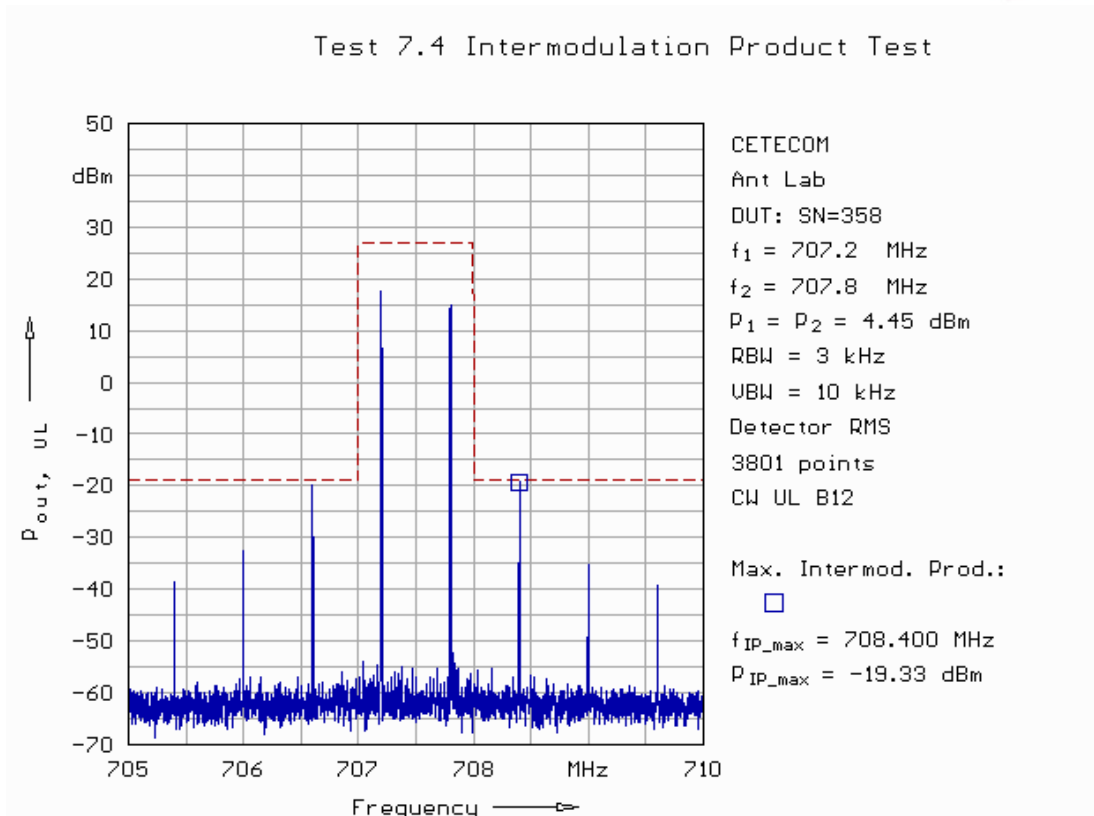

Fig. 42: Intermodulation test in uplink in band 12 at AGC.

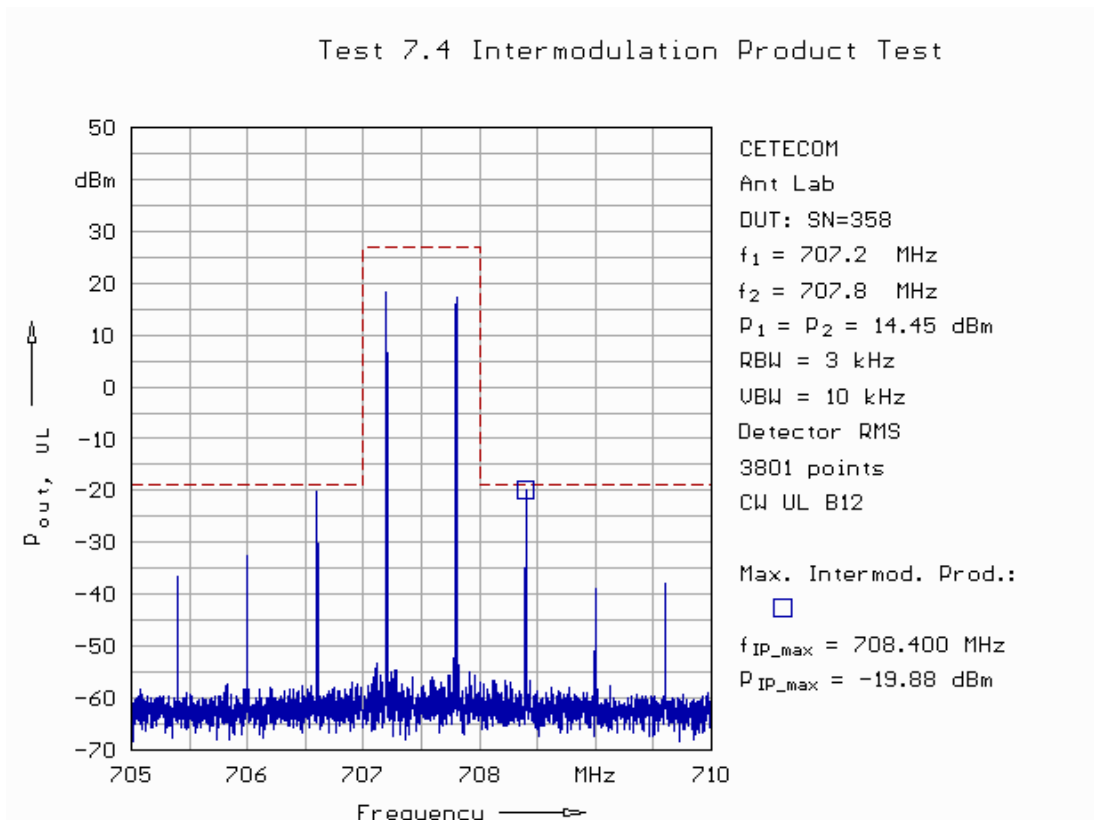

Fig. 43: Intermodulation test in uplink in band 12 at AGC plus 10 dB.

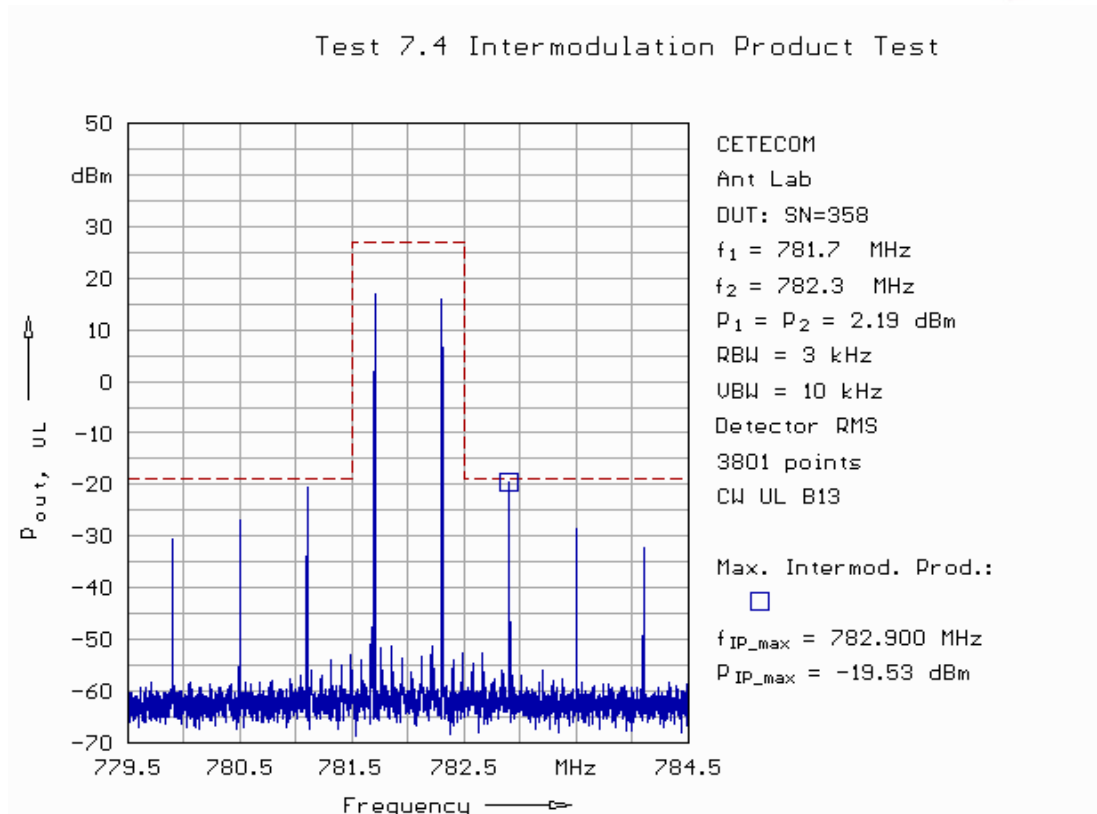

Fig. 44: Intermodulation test in uplink in band 13 at AGC.

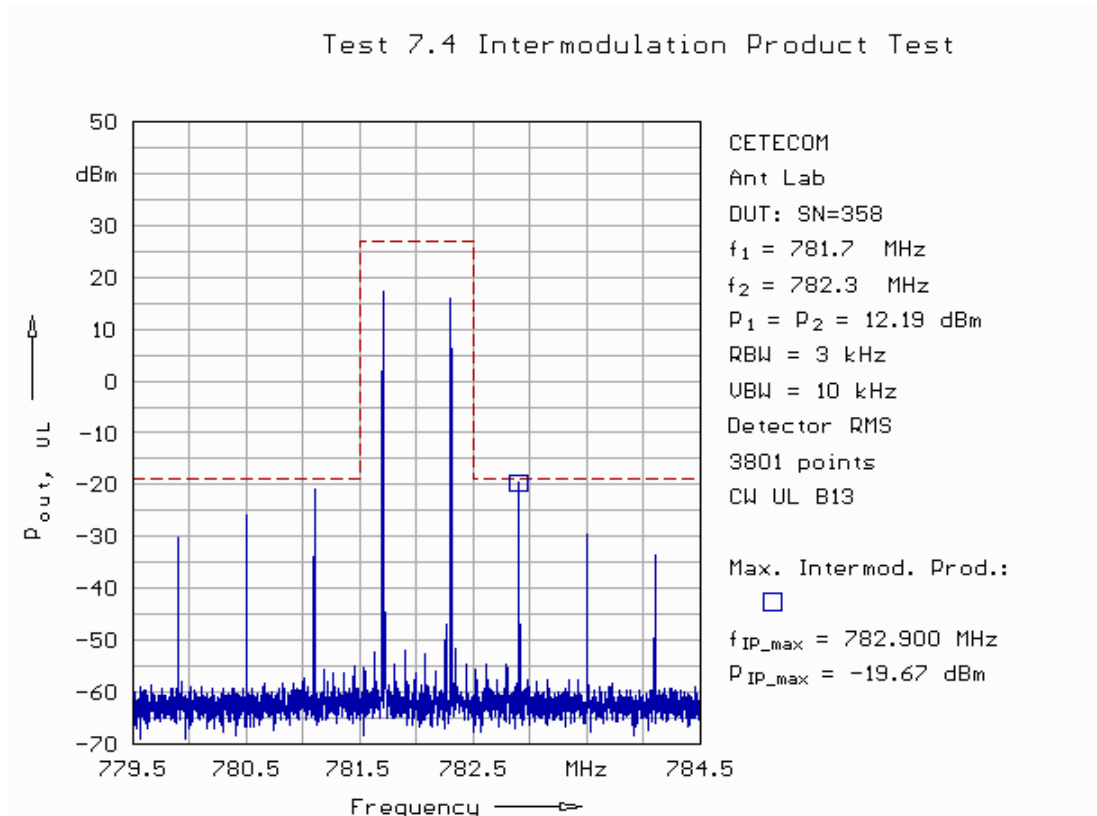

Fig. 45: Intermodulation test in uplink in band 13 at AGC plus 10 dB.

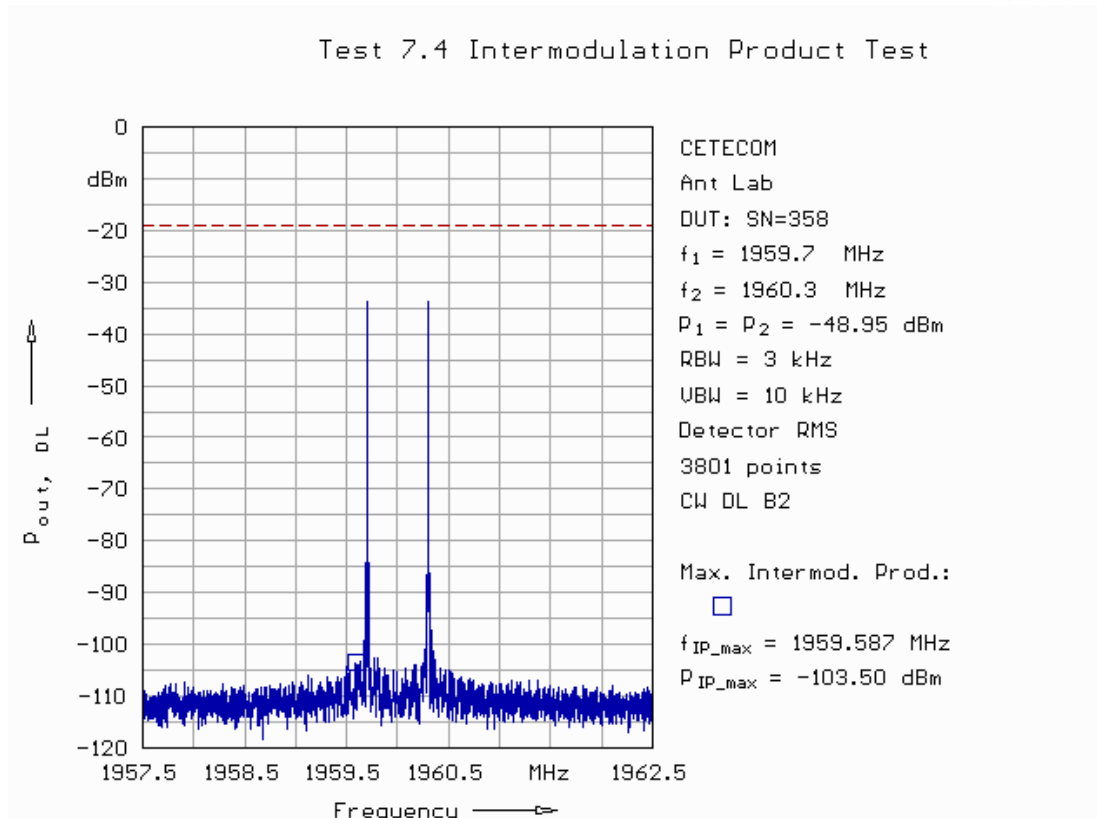

Fig. 46: Intermodulation test in downlink in band 2 at AGC.

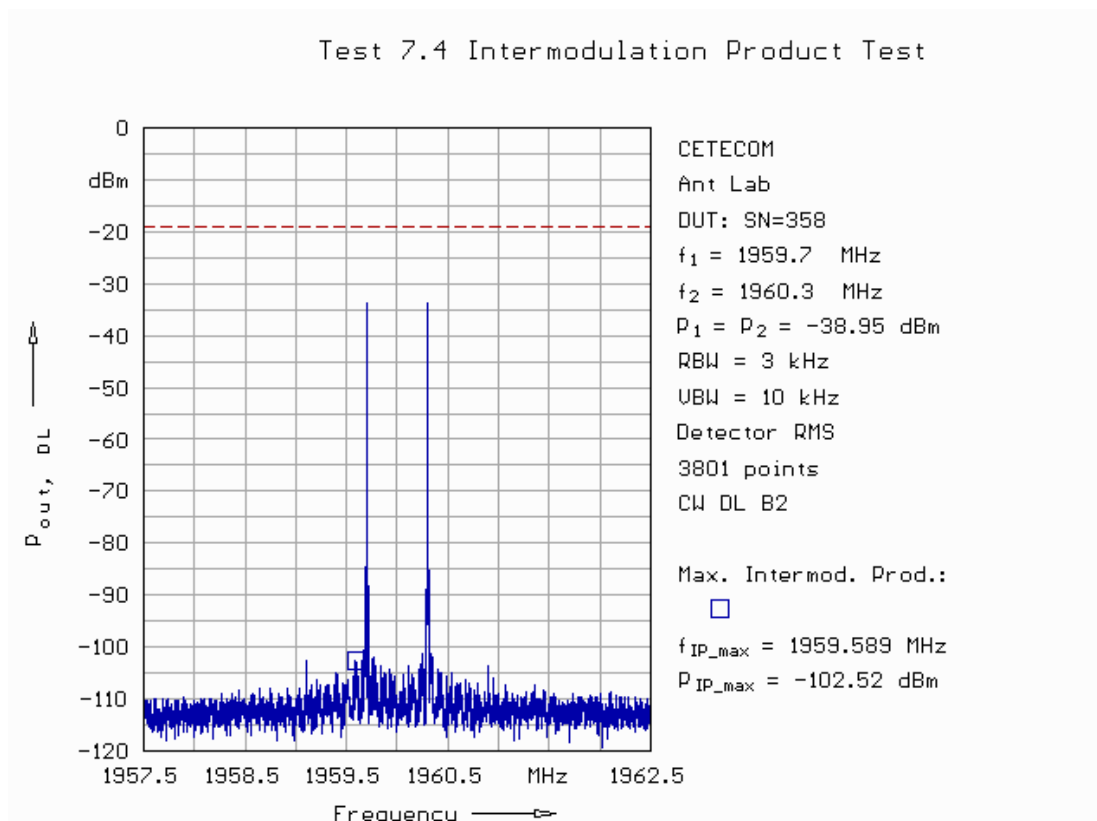

Fig. 47: Intermodulation test in downlink in band 2 at AGC plus 10 dB.

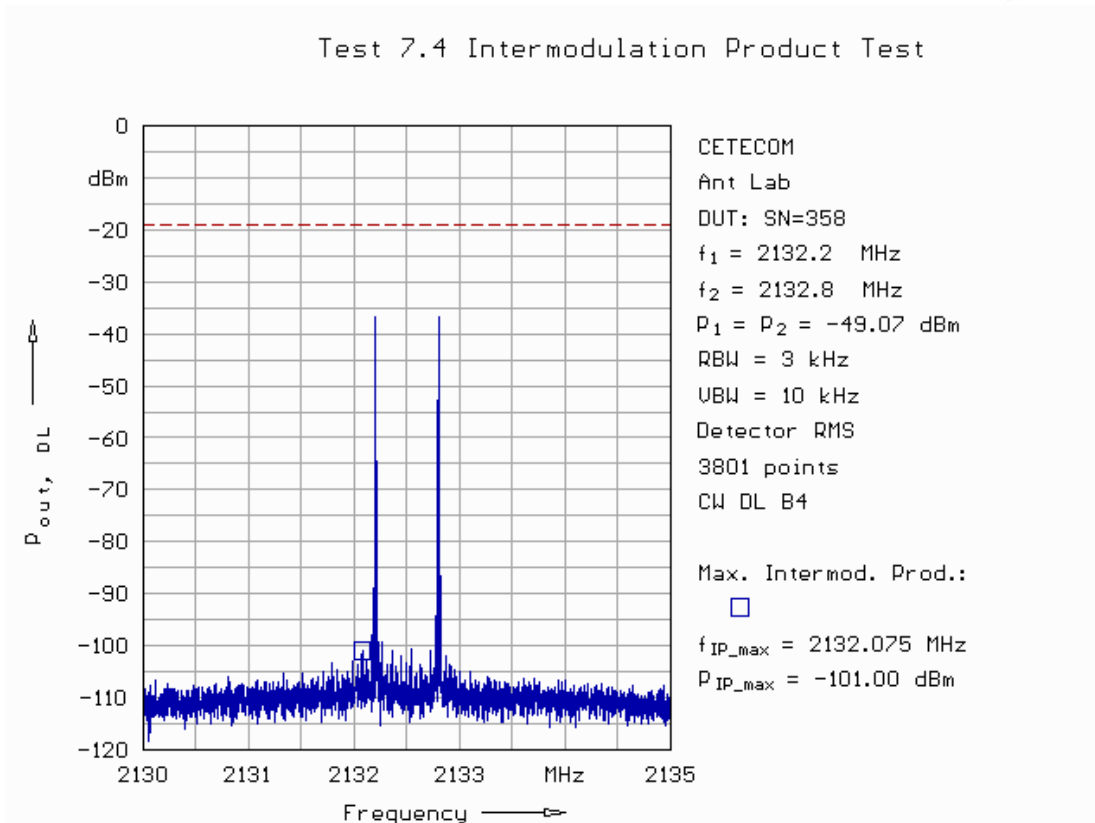

Fig. 48: Intermodulation test in downlink in band 4 at AGC.

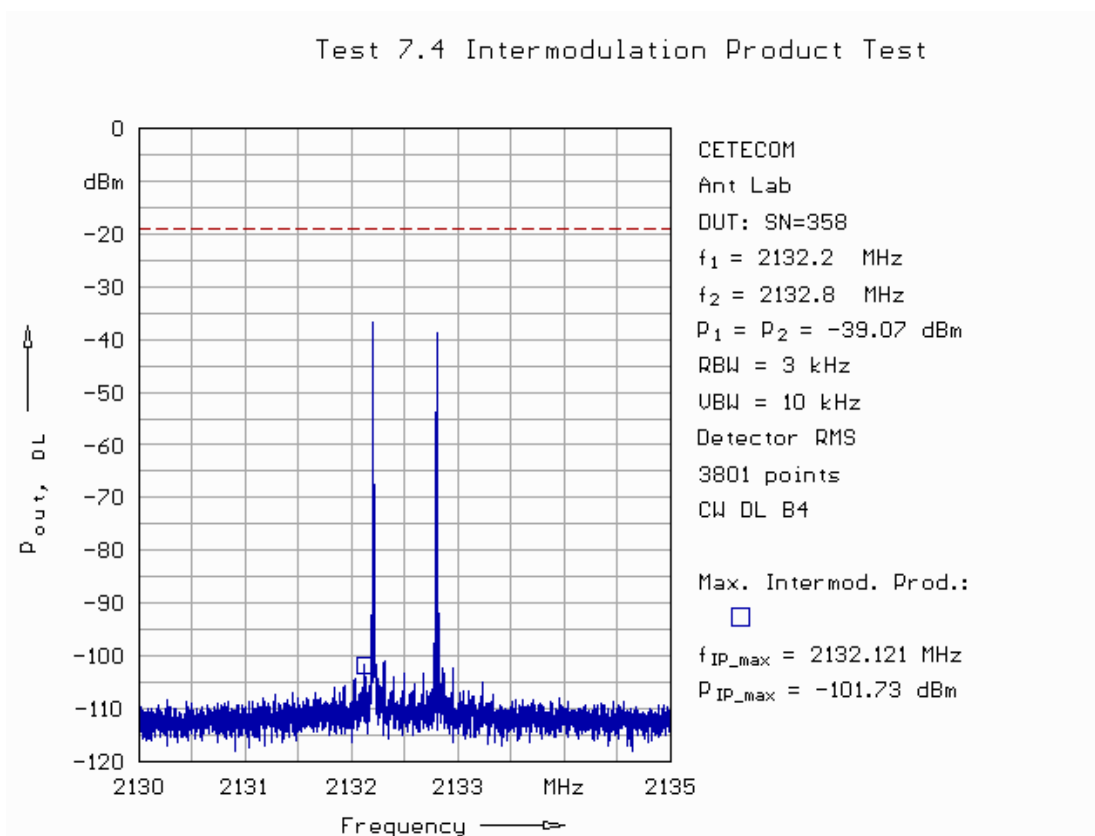

Fig. 49: Intermodulation test in downlink in band 4 at AGC plus 10 dB.

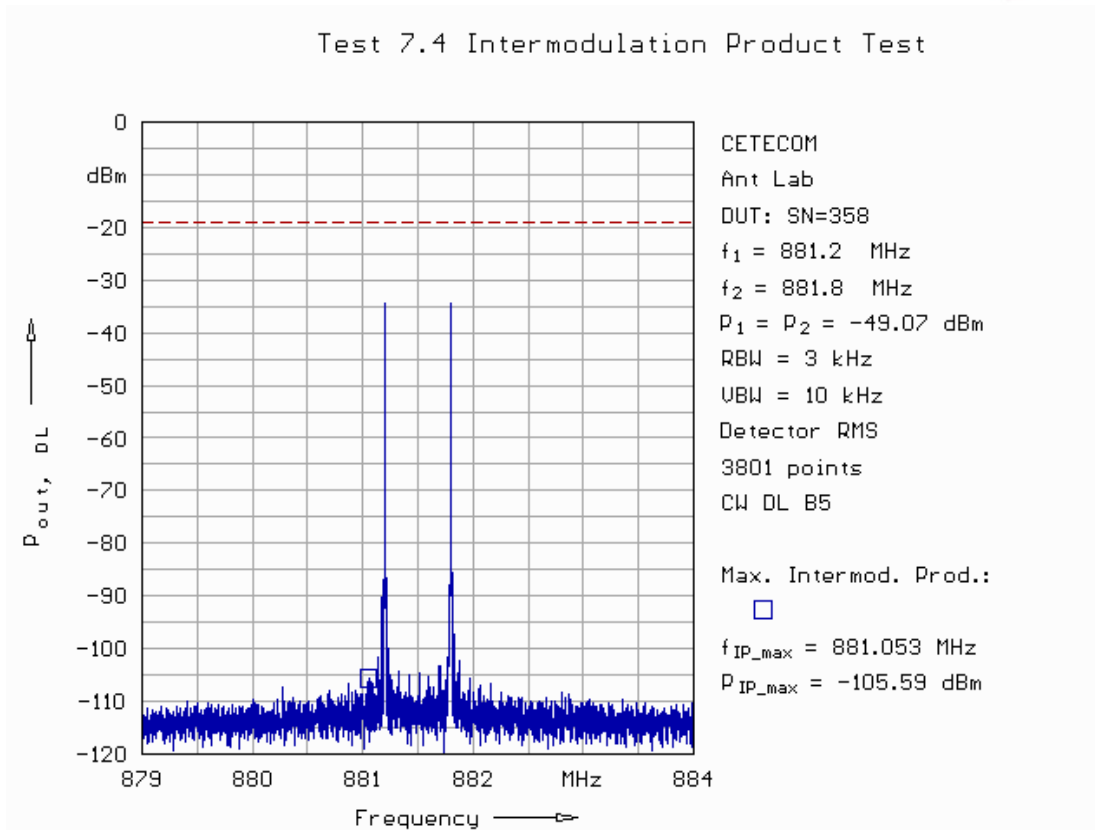

Fig. 50: Intermodulation test in downlink in band 5 at AGC.

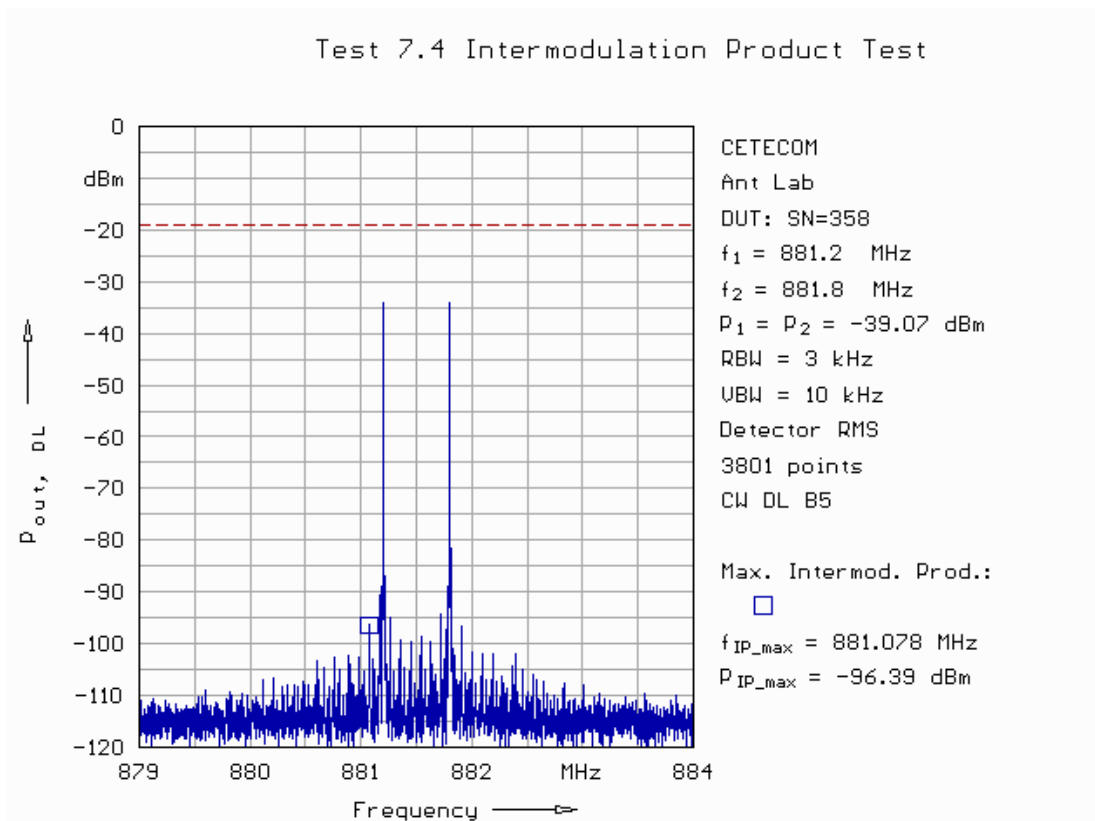

Fig. 51: Intermodulation test in downlink in band 5 at AGC plus 10 dB.

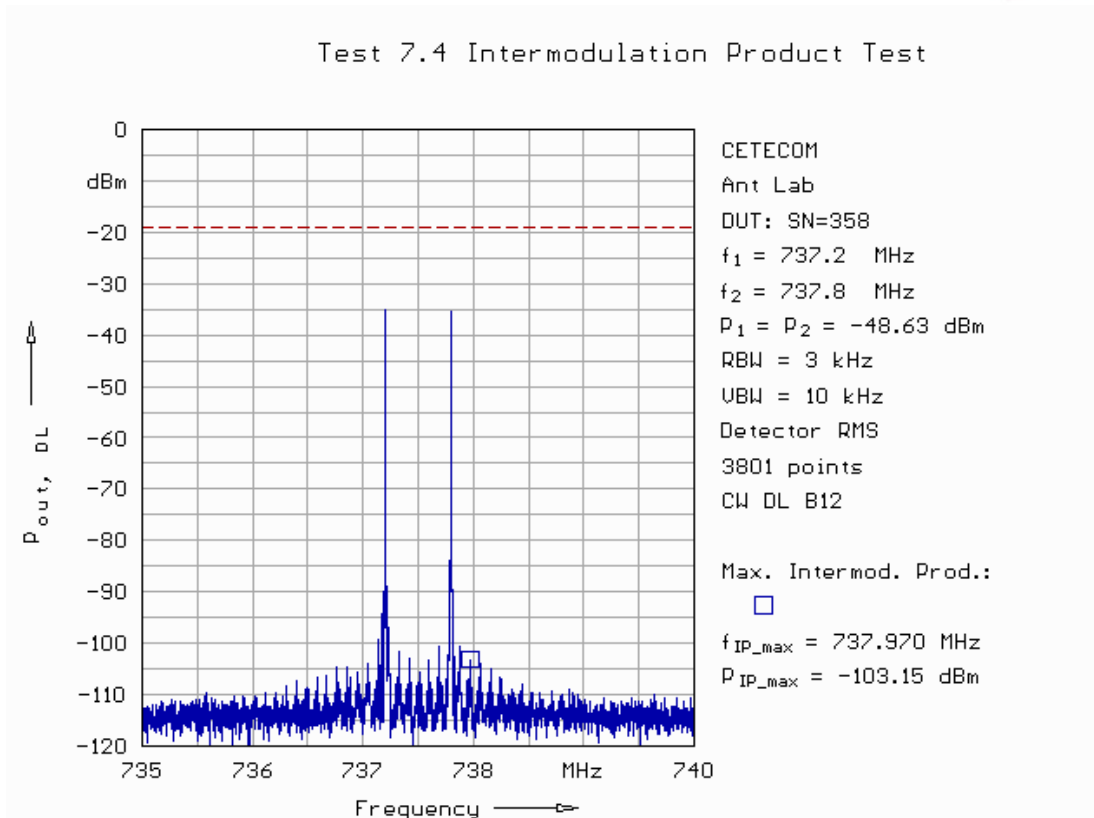

Fig. 52: Intermodulation test in downlink in band 12 at AGC.

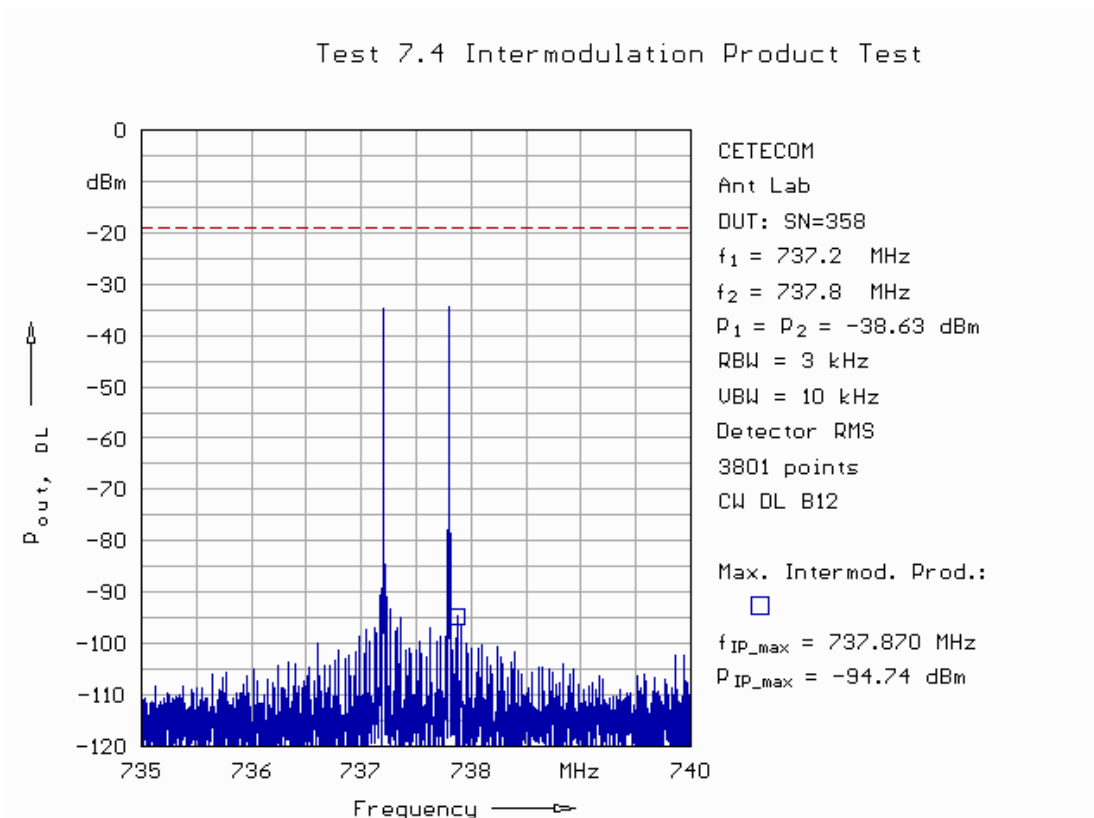

Fig. 53: Intermodulation test in downlink in band 12 at AGC plus 10 dB.

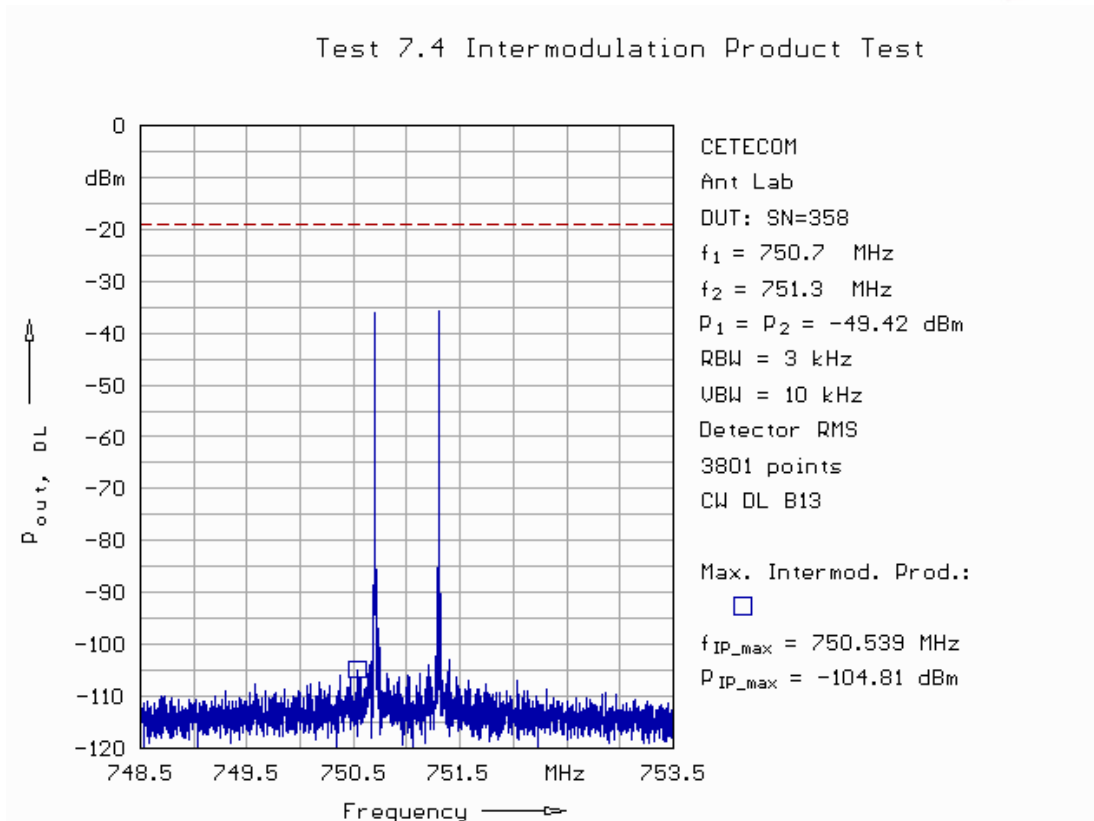

Fig. 54: Intermodulation test in downlink in band 13 at AGC.

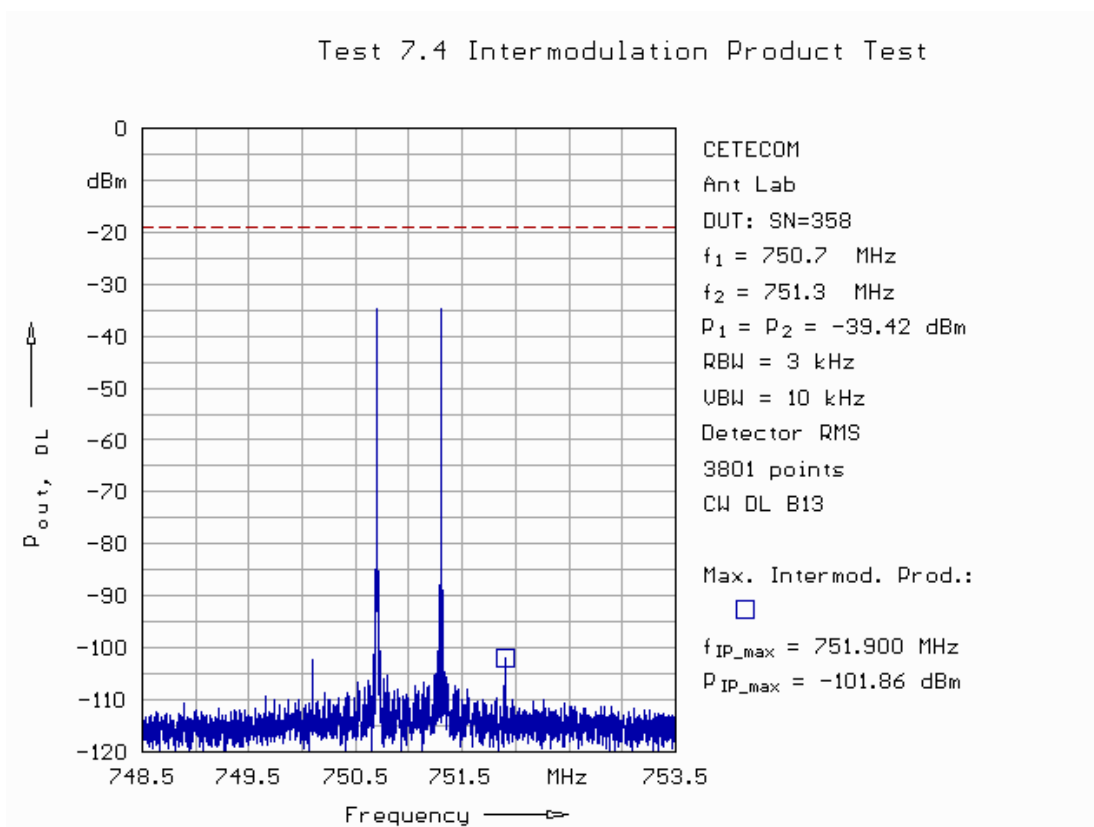

Fig. 55: Intermodulation test in downlink in band 13 at AGC plus 10 dB.

5.5. Out of Band Emission

The activated cable routing for this test is shown in Fig. 56 for GSM and CDMA in uplink and in Fig. 58 for LTE in uplink, in Fig. 57 and Fig. 59 for GSM and CDMA in downlink and for LTE in downlink, respectively.

As illustrated on the next pages the EUT meets the limit of -19 dBm in all required conditions for Out of Band Emissions.

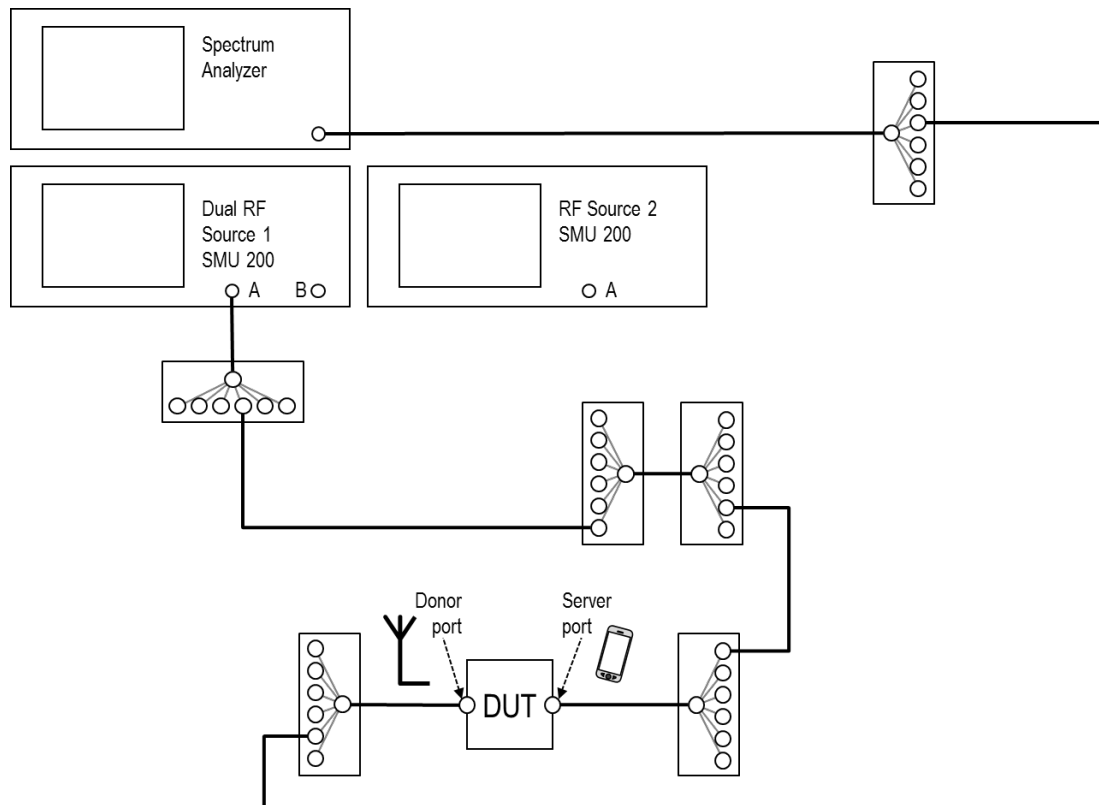

Fig. 56: Set up for out of band emission tests for GSM and CDMA in uplink.

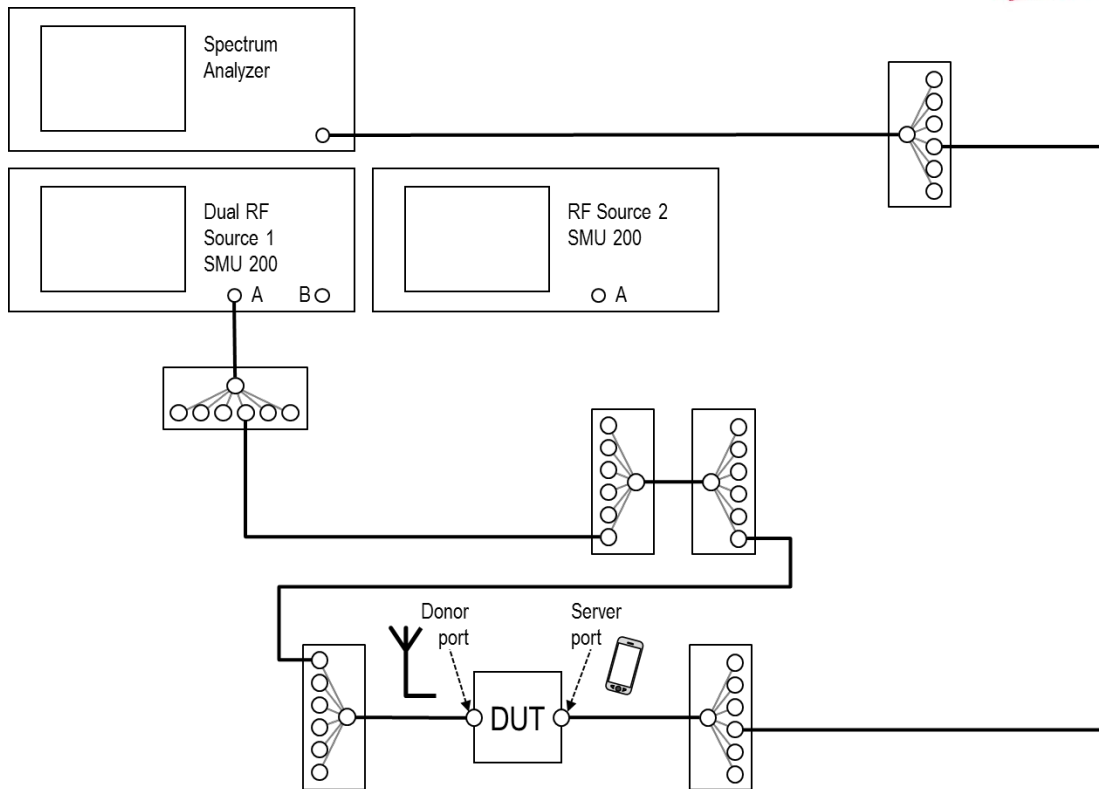

Fig. 57: Set up for out of band emission tests for GSM and CDMA in downlink.

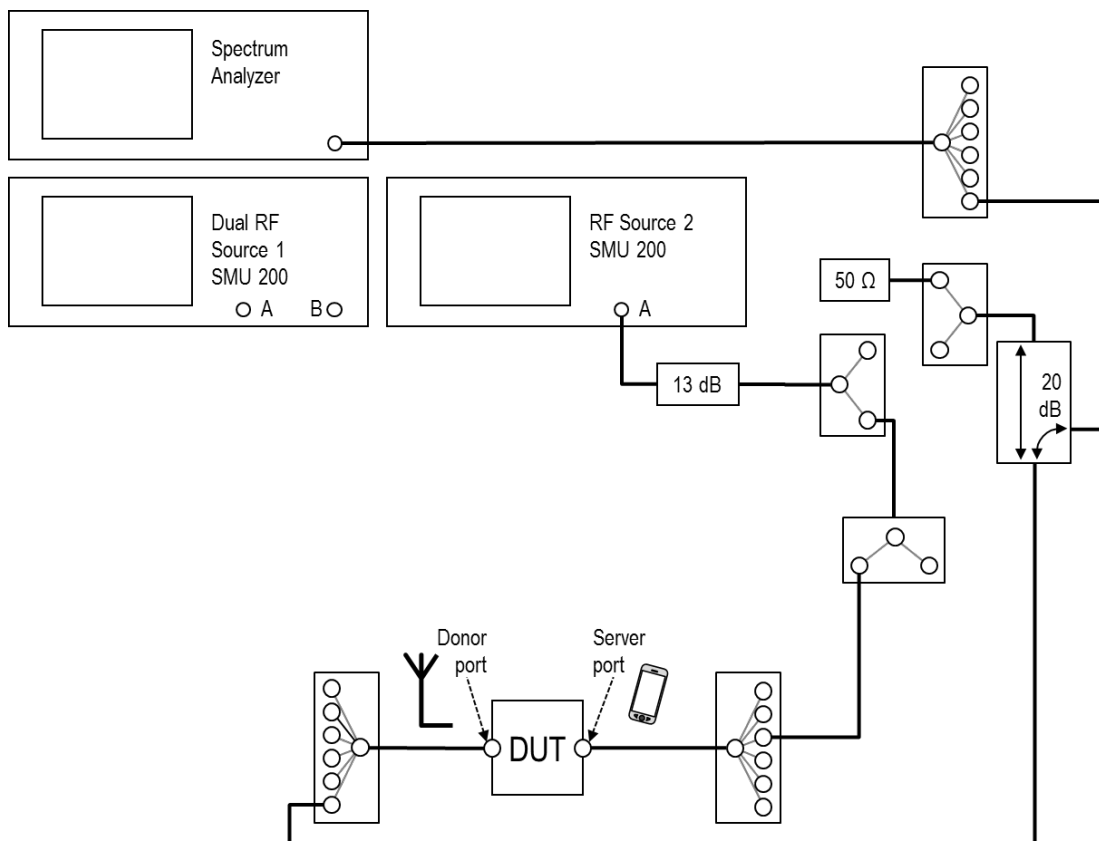

Fig. 58: Set up for out of band emission tests for LTE in uplink.

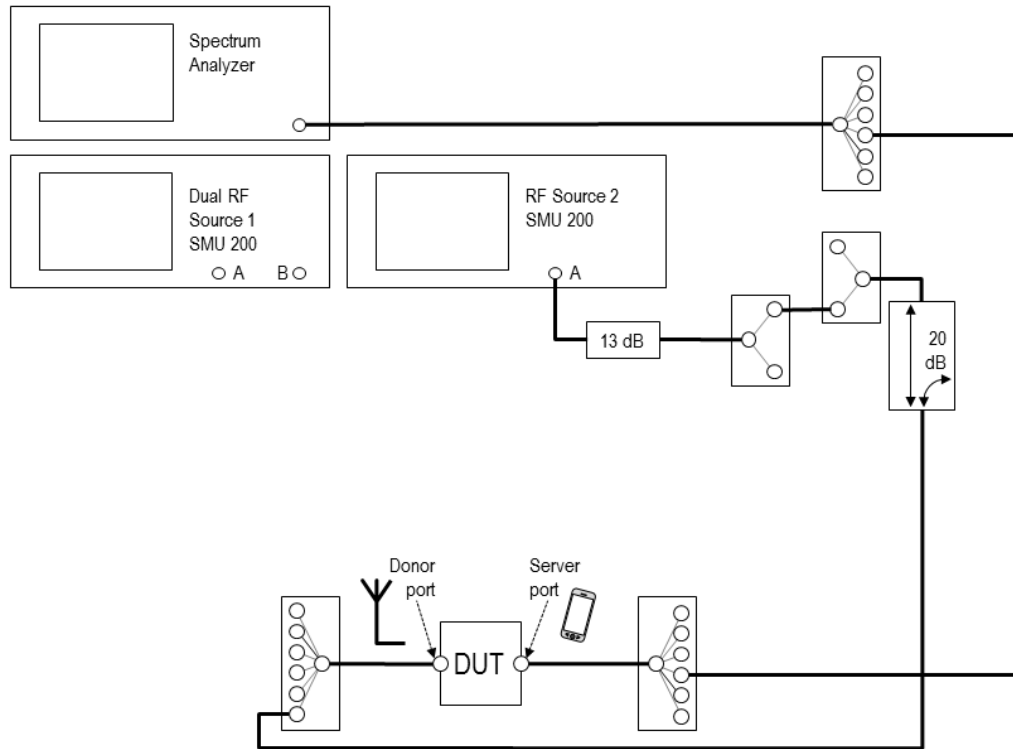

Fig. 59: Set up for out of band emission tests for LTE in downlink.

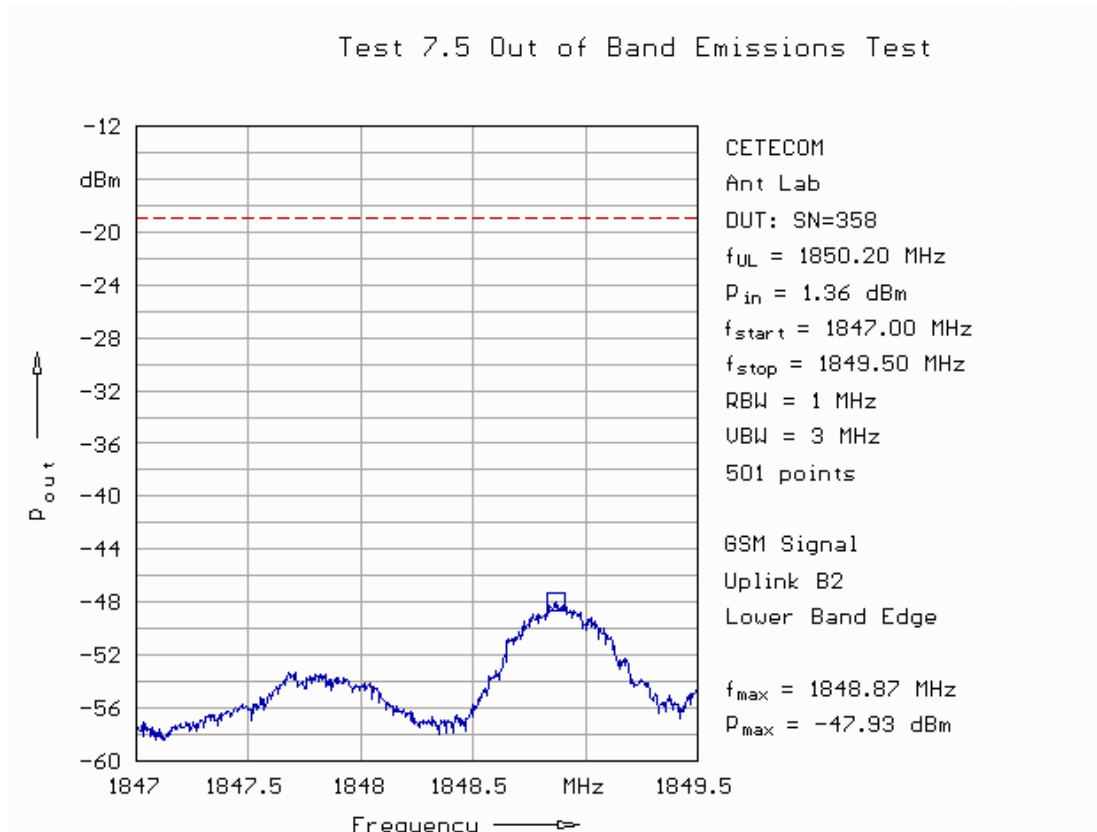

Fig. 60: Out-of-band emissions in uplink in band 2 applying a GSM signal for the lower band edge.

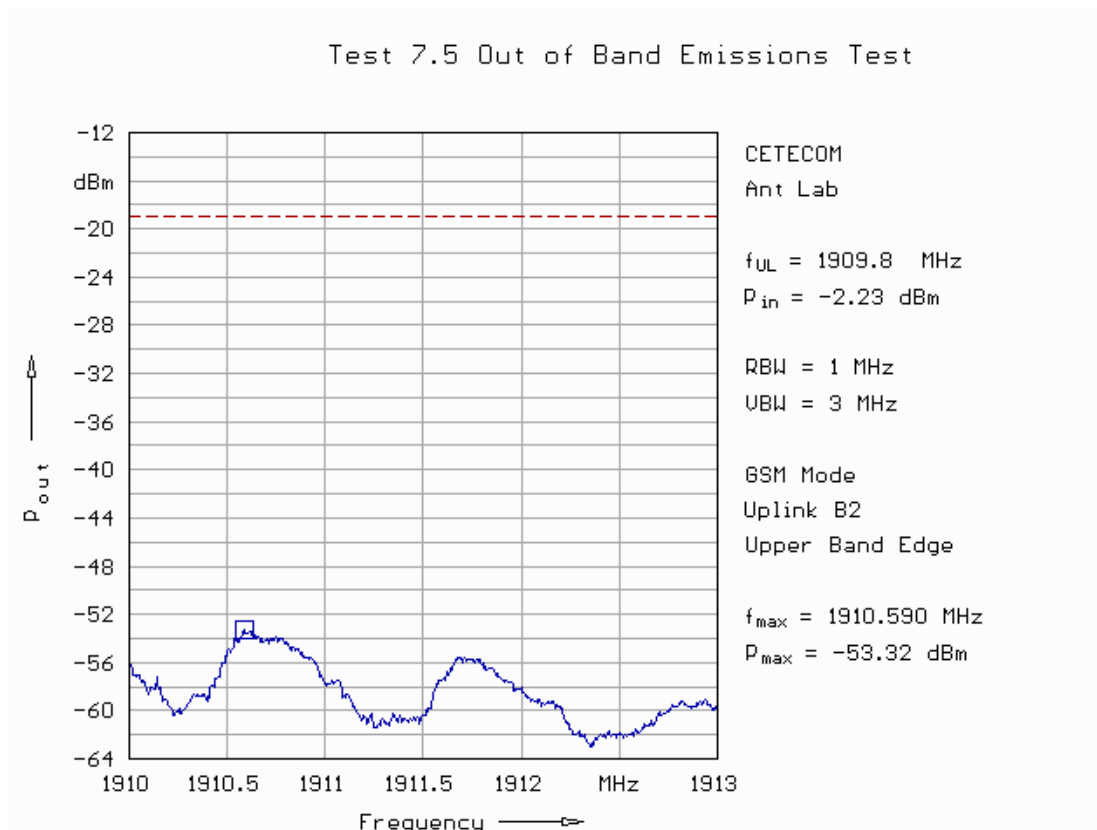

Fig. 61: Out-of-band emissions in uplink in band 2 applying a GSM signal for the upper band edge.

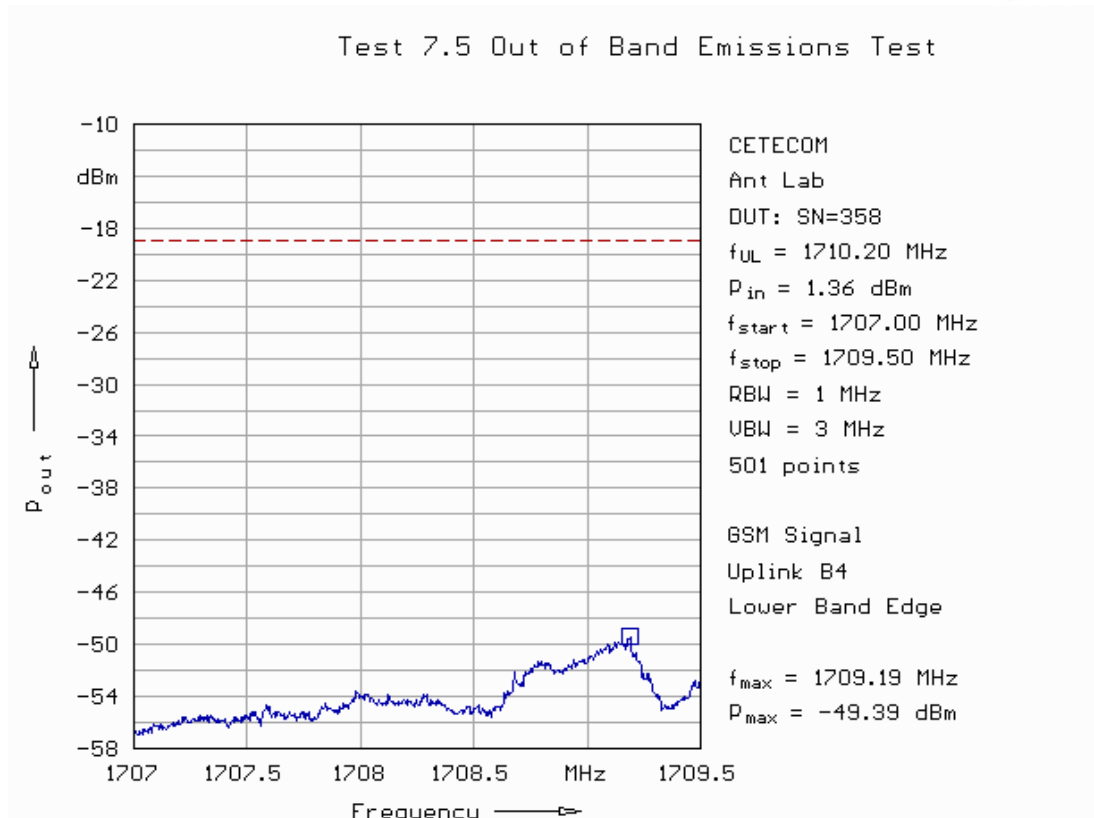

Fig. 62: Out-of-band emissions in uplink in band 4 applying a GSM signal for the lower band edge.

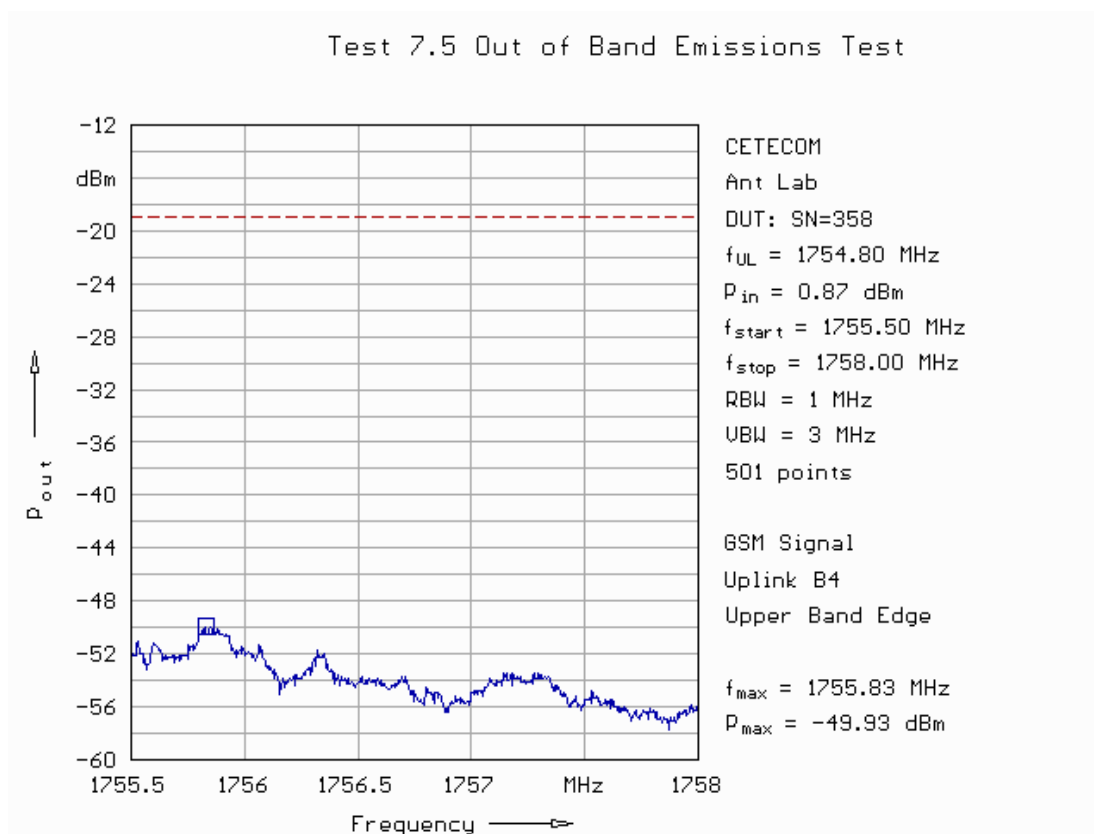

Fig. 63: Out-of-band emissions in uplink in band 4 applying a GSM signal for the upper band edge.

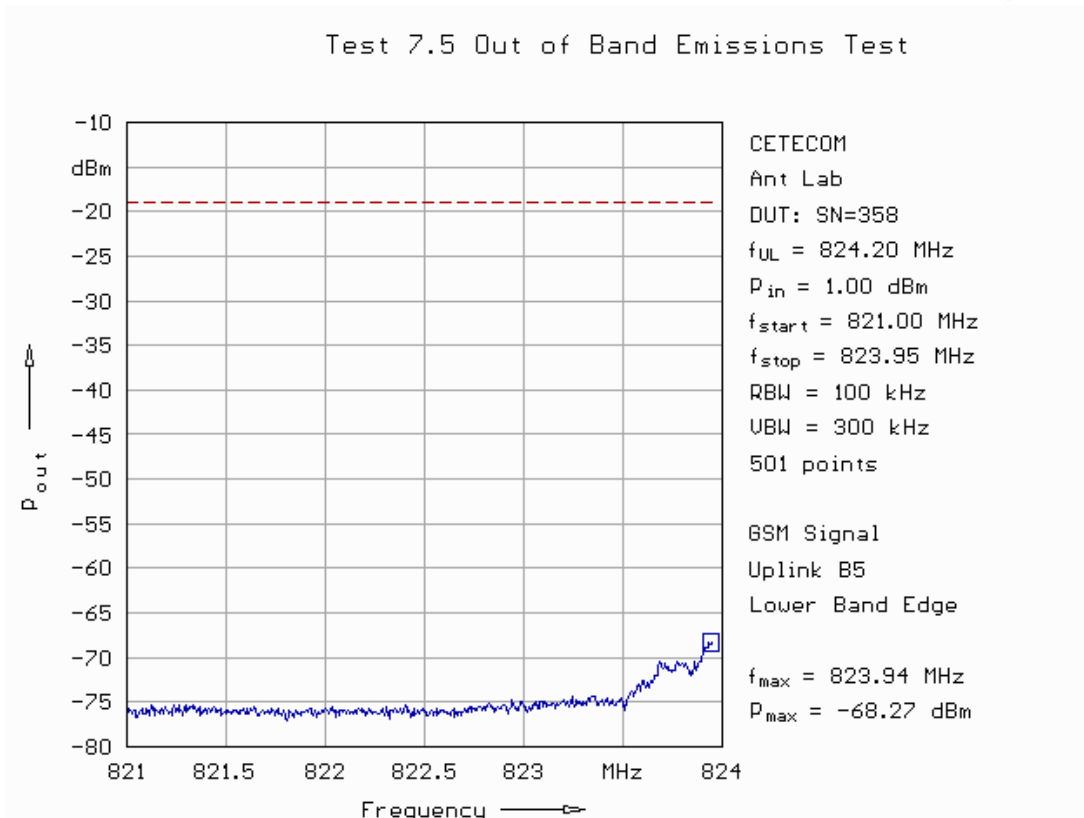

Fig. 64: Out-of-band emissions in uplink in band 5 applying a GSM signal for the lower band edge.

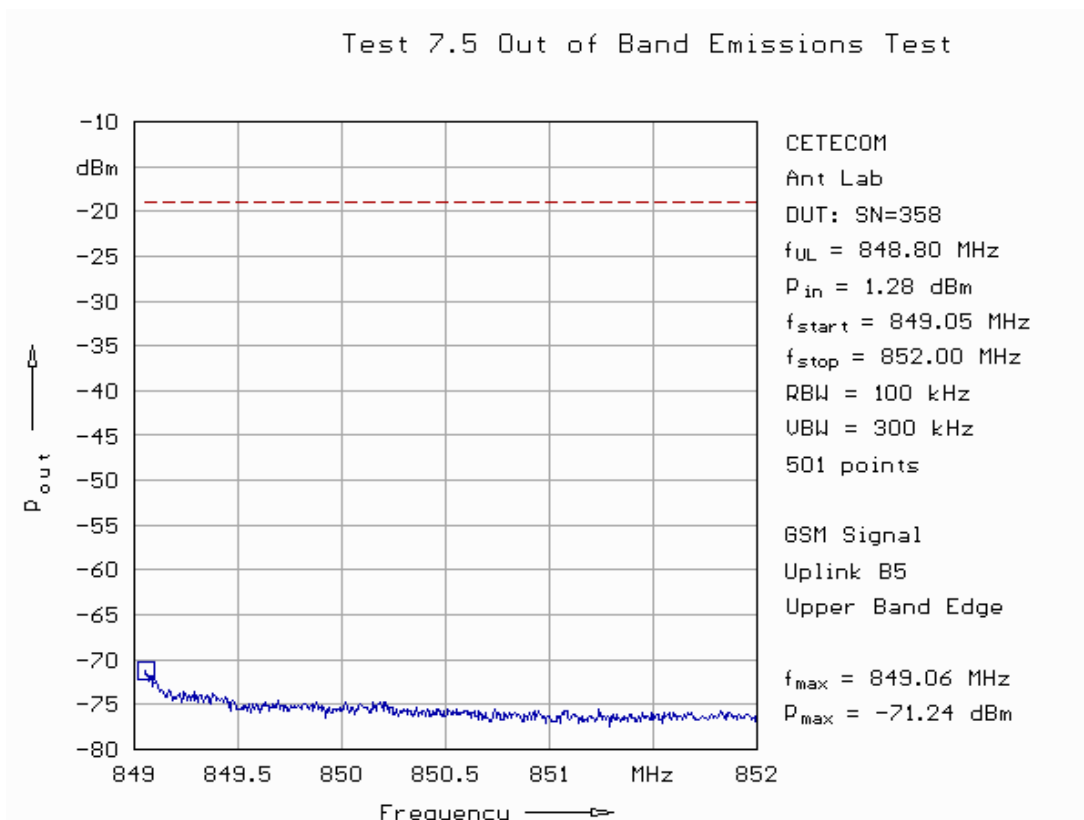

Fig. 65: Out-of-band emissions in uplink in band 5 applying a GSM signal for the upper band edge.

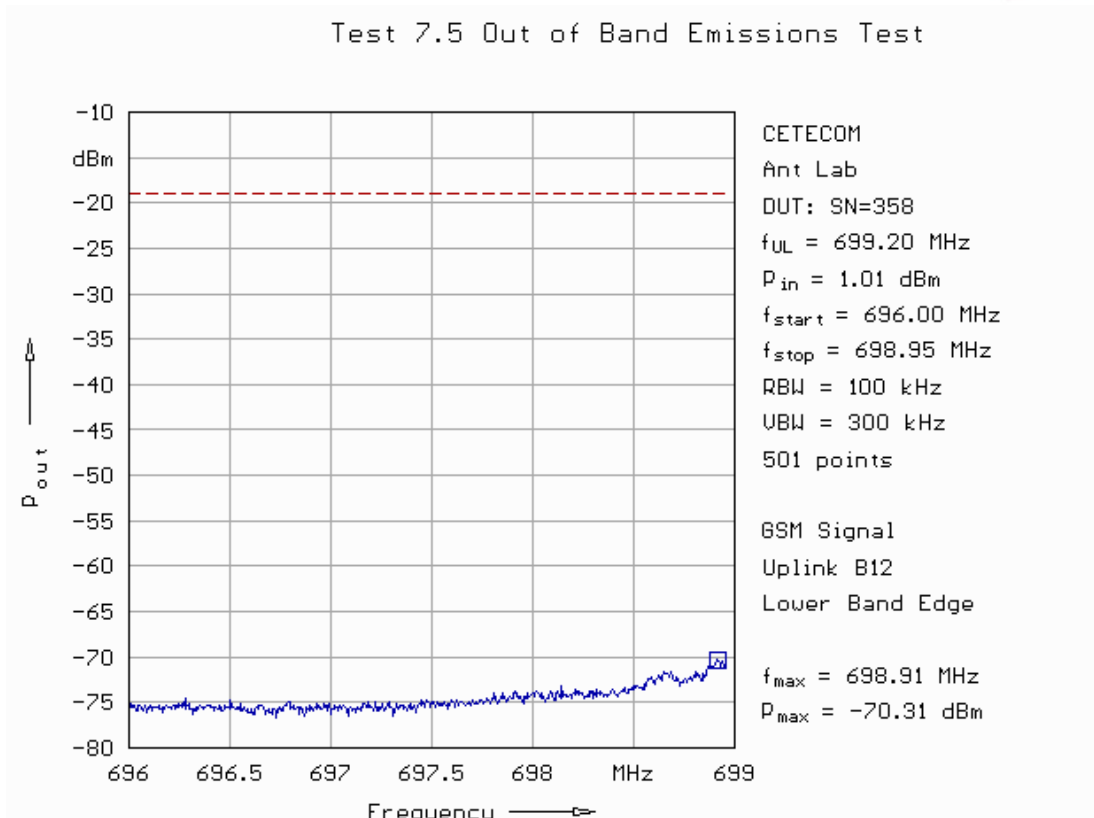

Fig. 66: Out-of-band emissions in uplink in band 12 applying a GSM signal for the lower band edge.

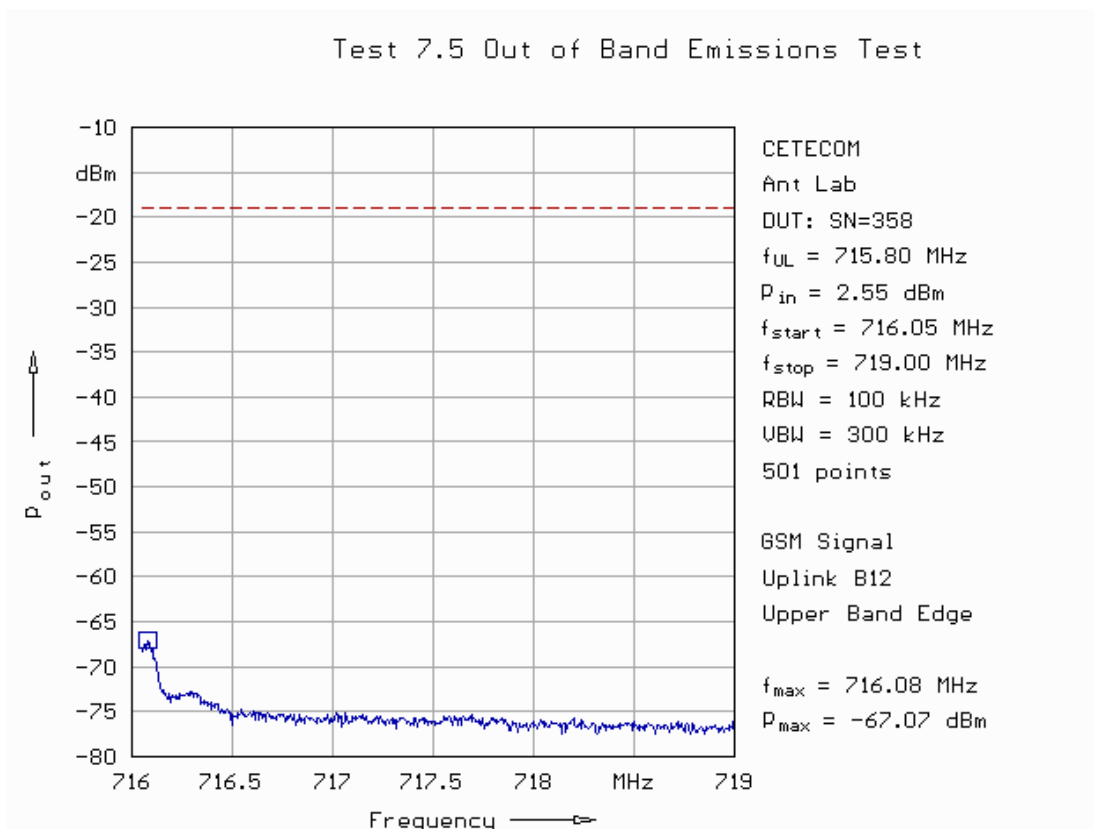

Fig. 67: Out-of-band emissions in uplink in band 12 applying a GSM signal for the upper band edge.

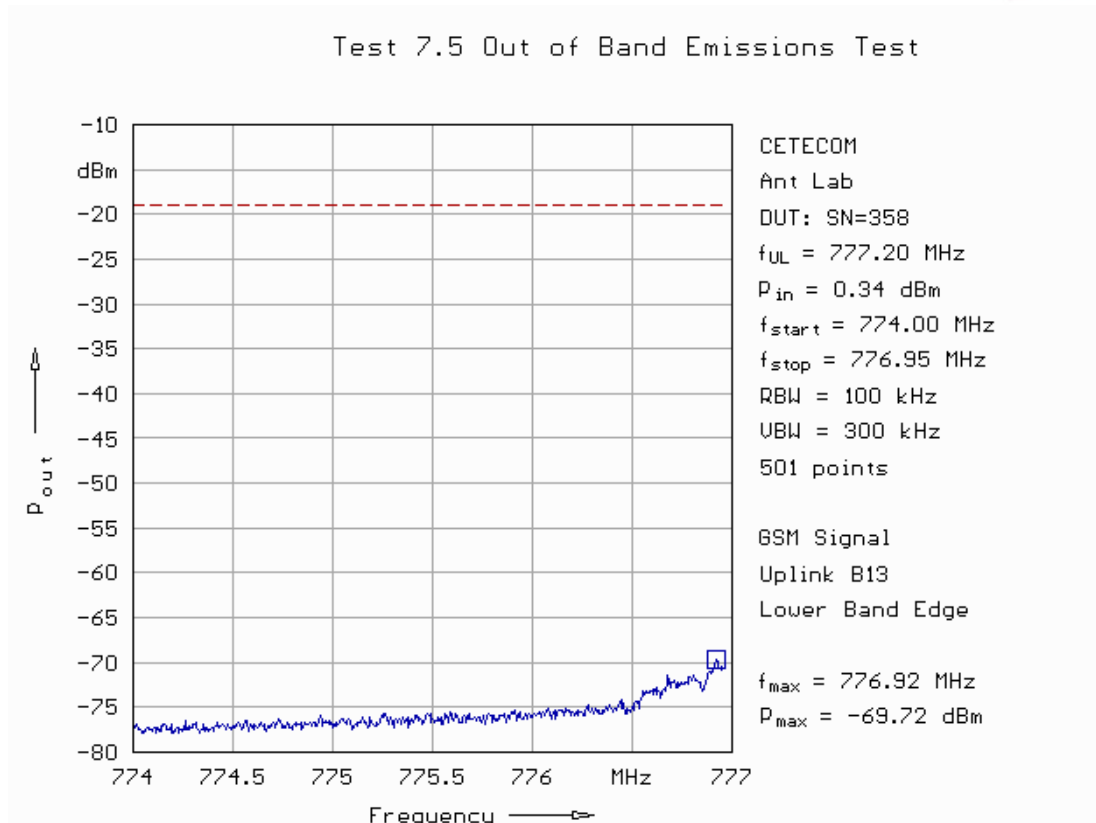

Fig. 68: Out-of-band emissions in uplink in band 13 applying a GSM signal for the lower band edge.

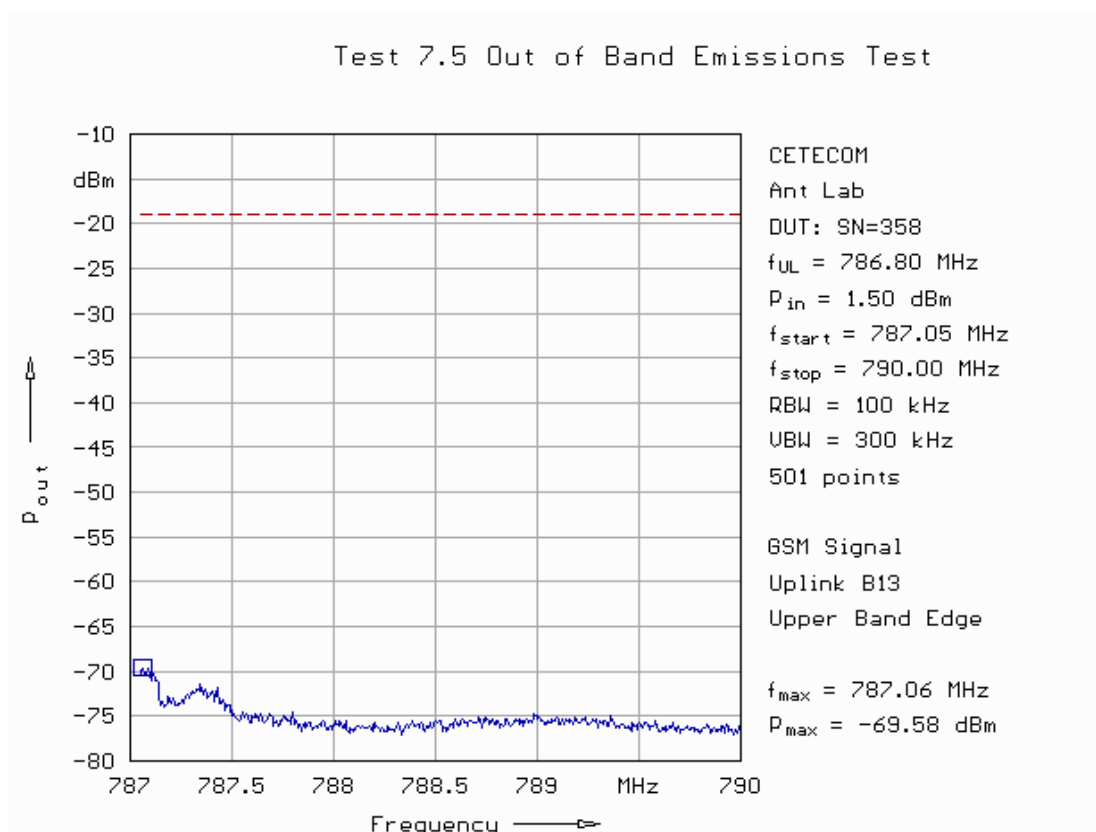

Fig. 69: Out-of-band emissions in uplink in band 13 applying a GSM signal for the upper band edge.

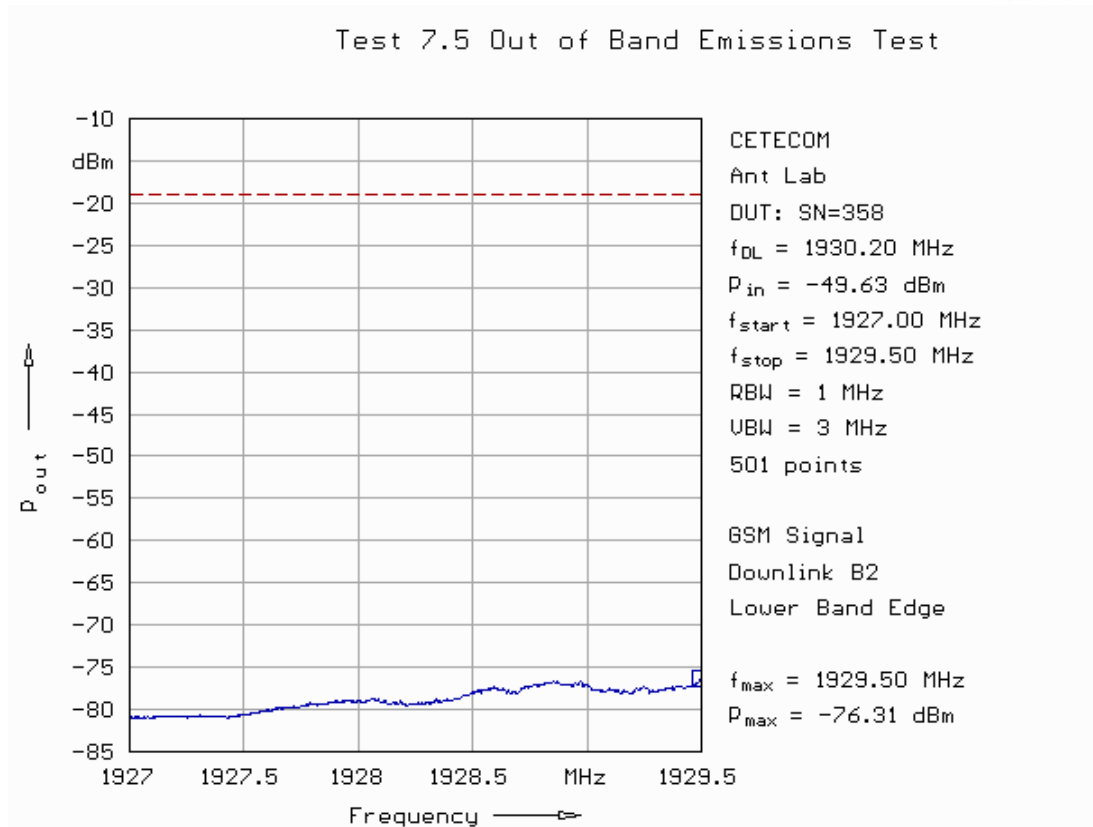

Fig. 70: Out-of-band emissions in downlink in band 2 applying a GSM signal for the lower band edge.

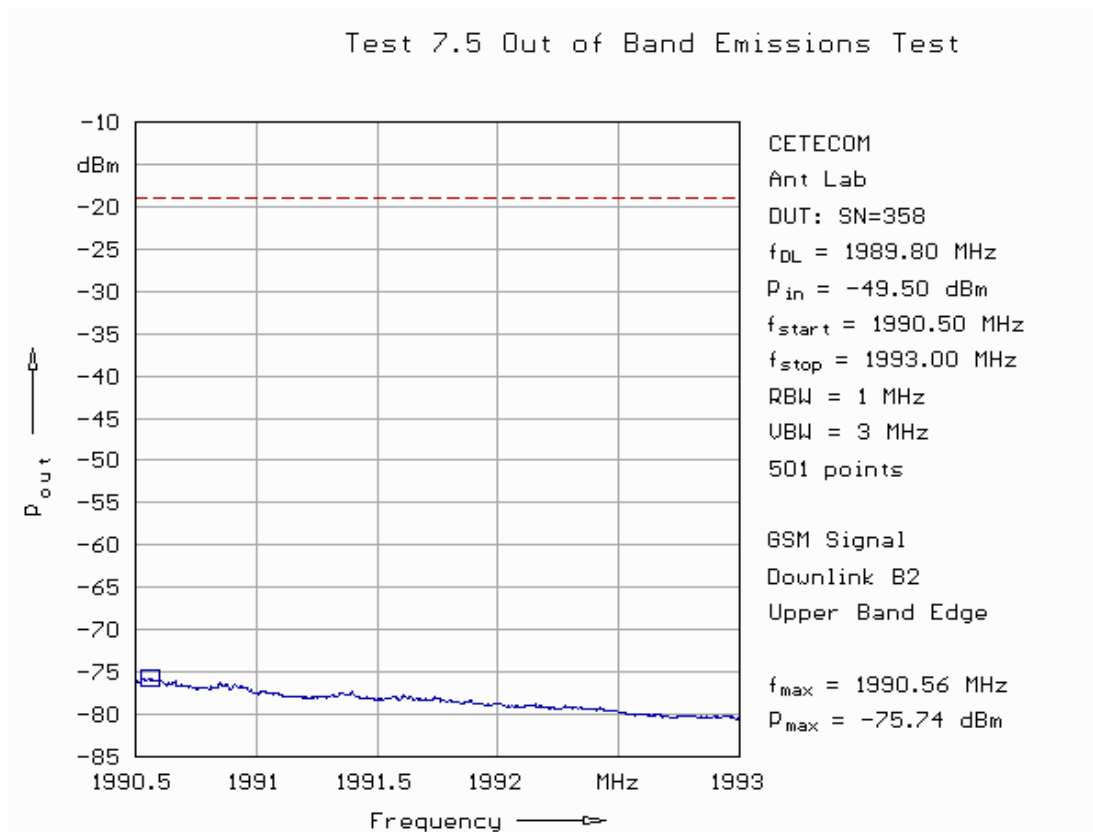

Fig. 71: Out-of-band emissions in downlink in band 2 applying a GSM signal for the upper band edge.

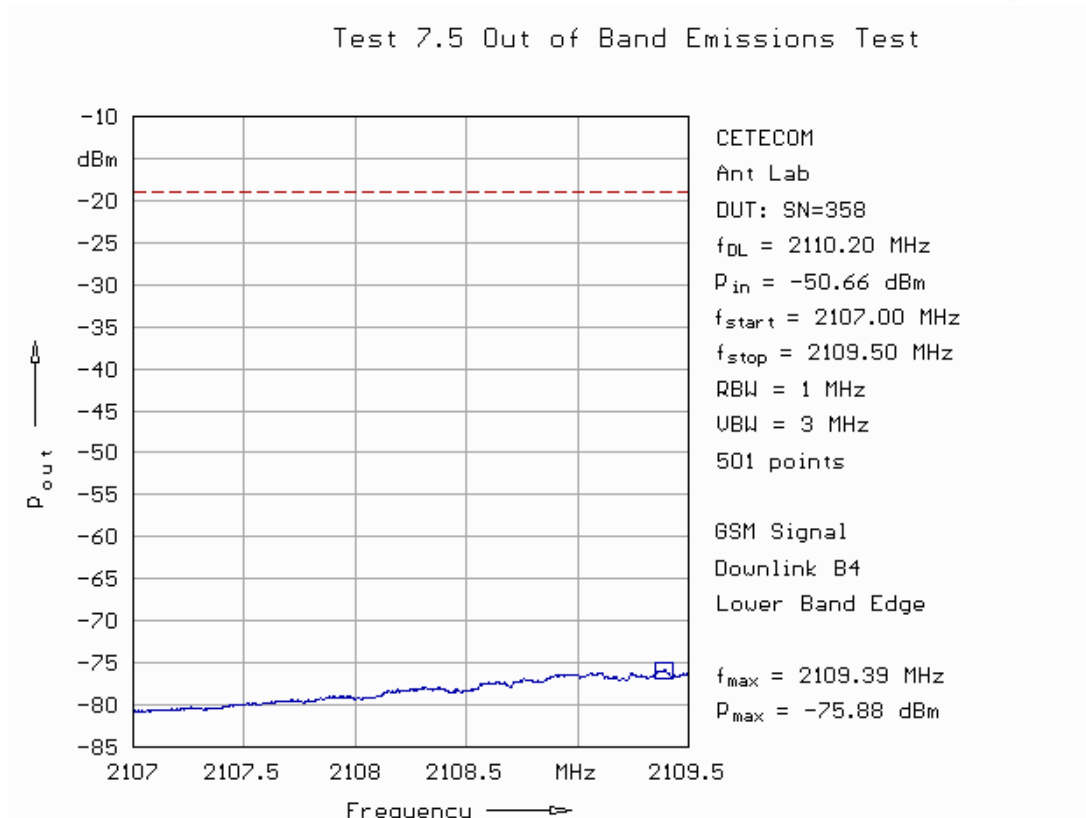

Fig. 72: Out-of-band emissions in downlink in band 4 applying a GSM signal for the lower band edge.

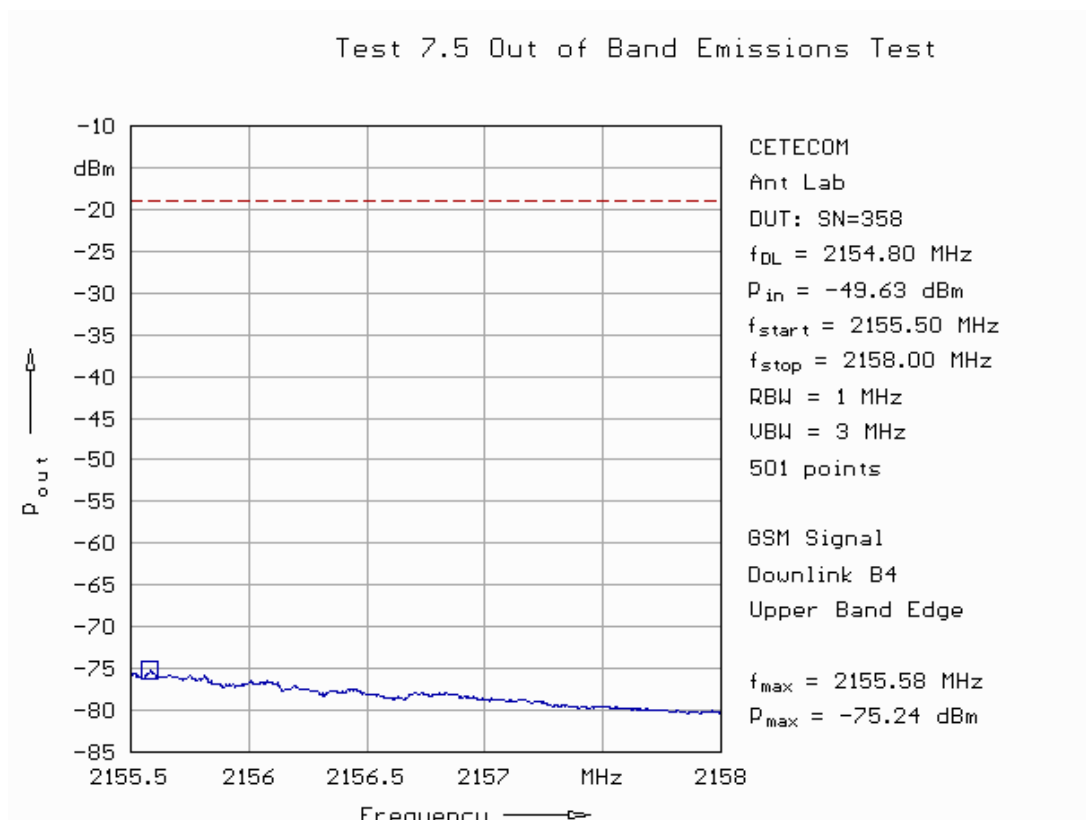

Fig. 73: Out-of-band emissions in downlink in band 4 applying a GSM signal for the upper band edge.

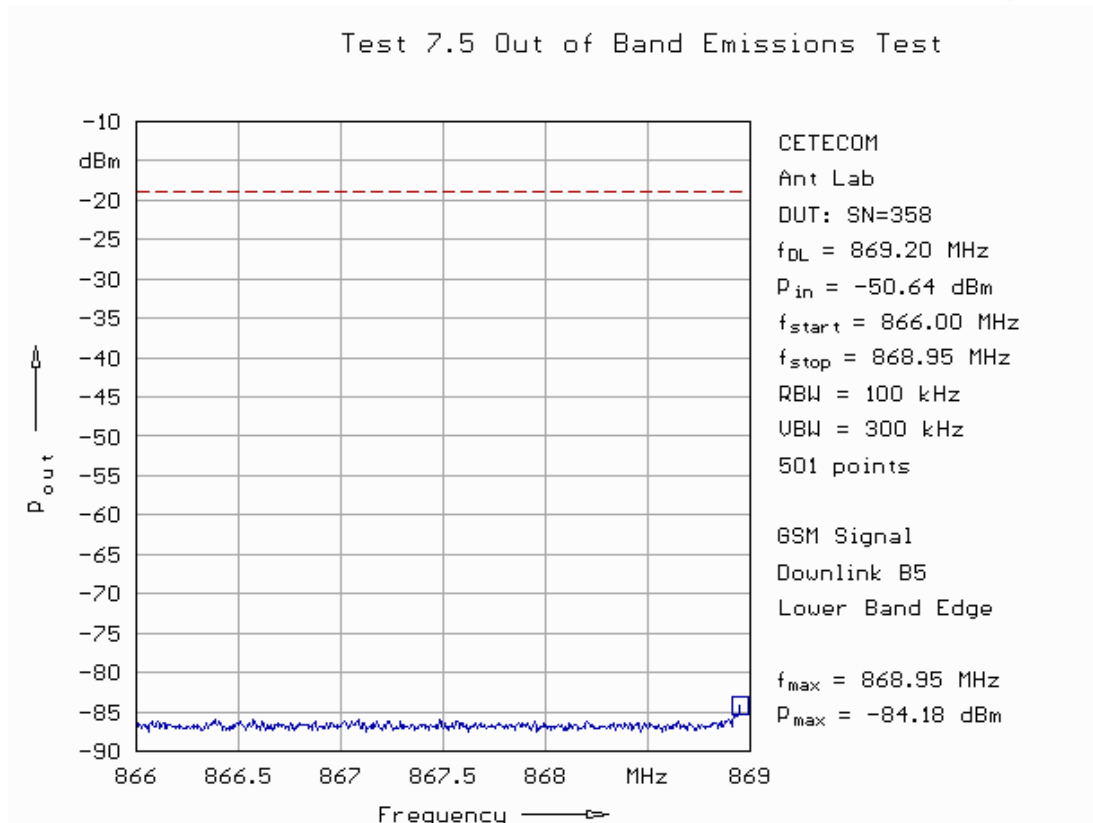

Fig. 74: Out-of-band emissions in downlink in band 5 applying a GSM signal for the lower band edge.

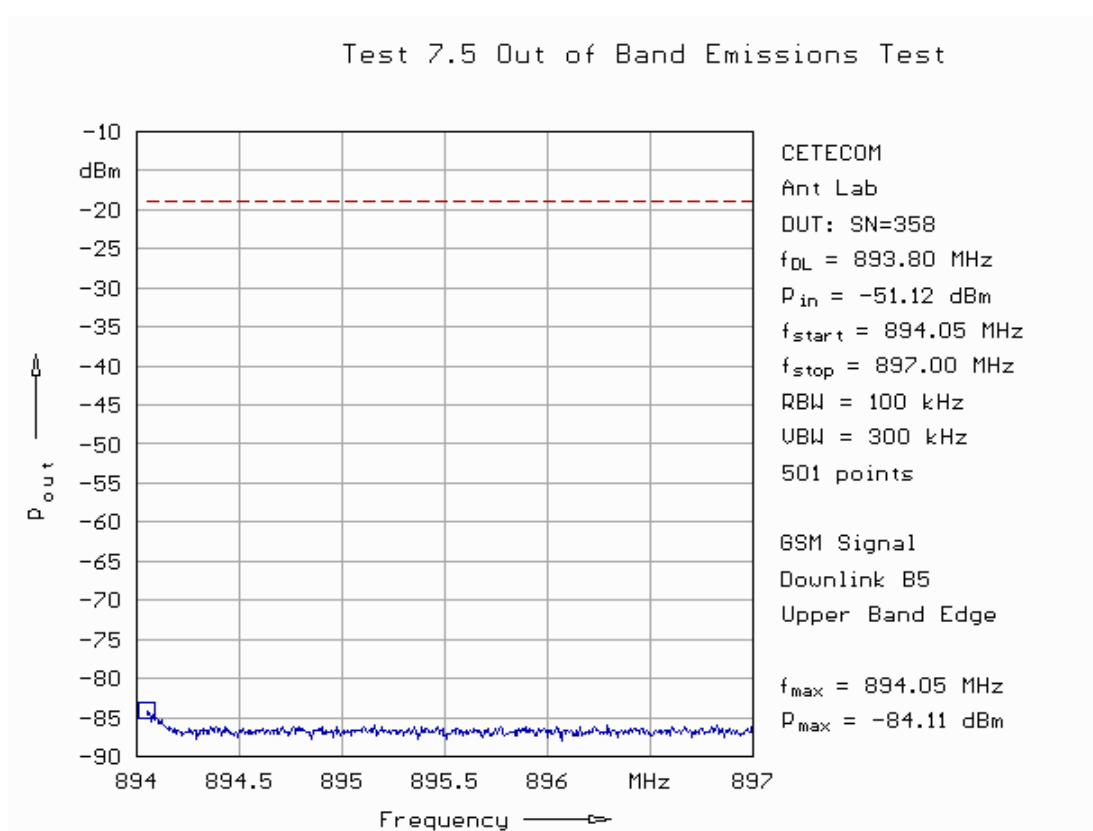

Fig. 75: Out-of-band emissions in downlink in band 5 applying a GSM signal for the upper band edge.

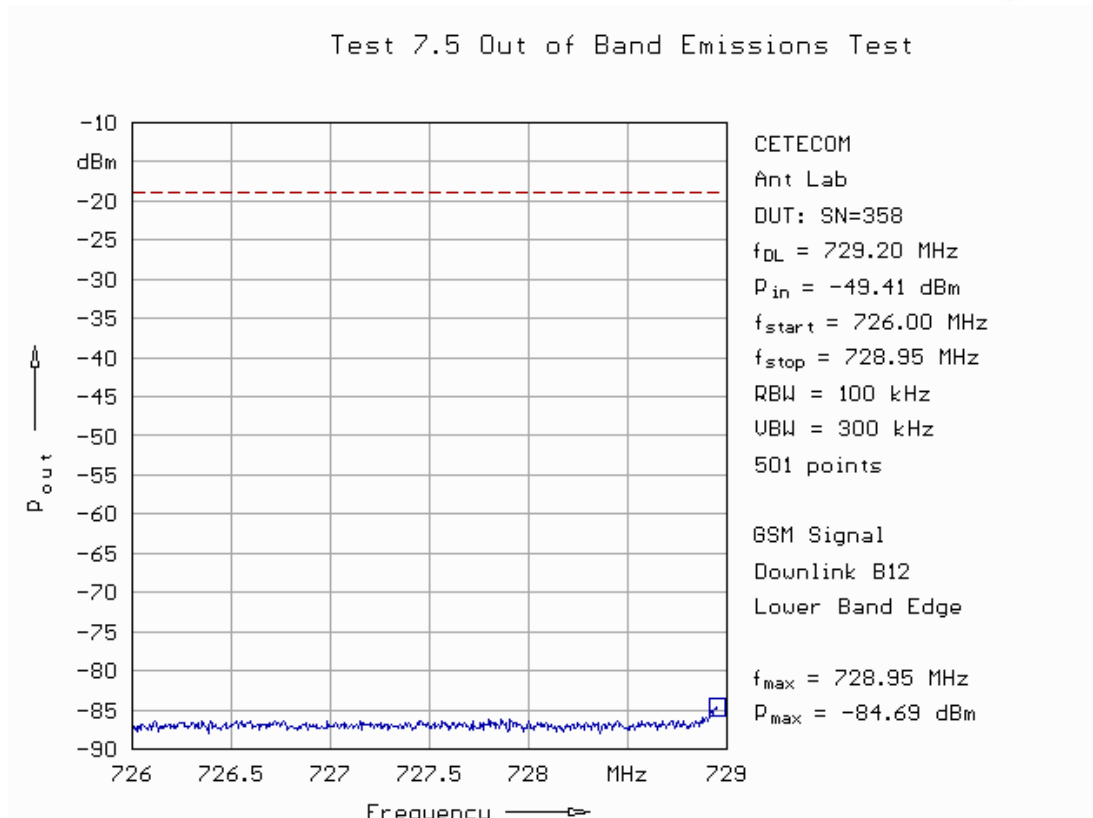

Fig. 76: Out-of-band emissions in downlink in band 12 applying a GSM signal for the lower band edge.

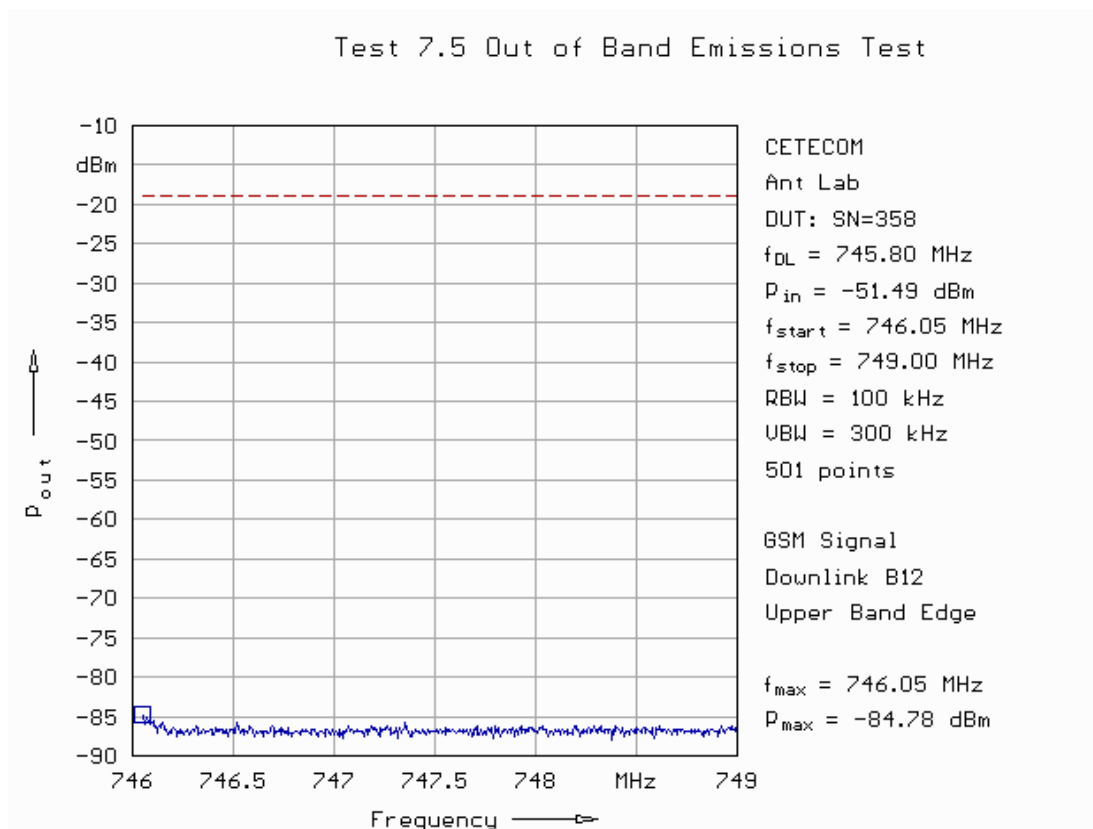

Fig. 77: Out-of-band emissions in downlink in band 12 applying a GSM signal for the upper band edge.

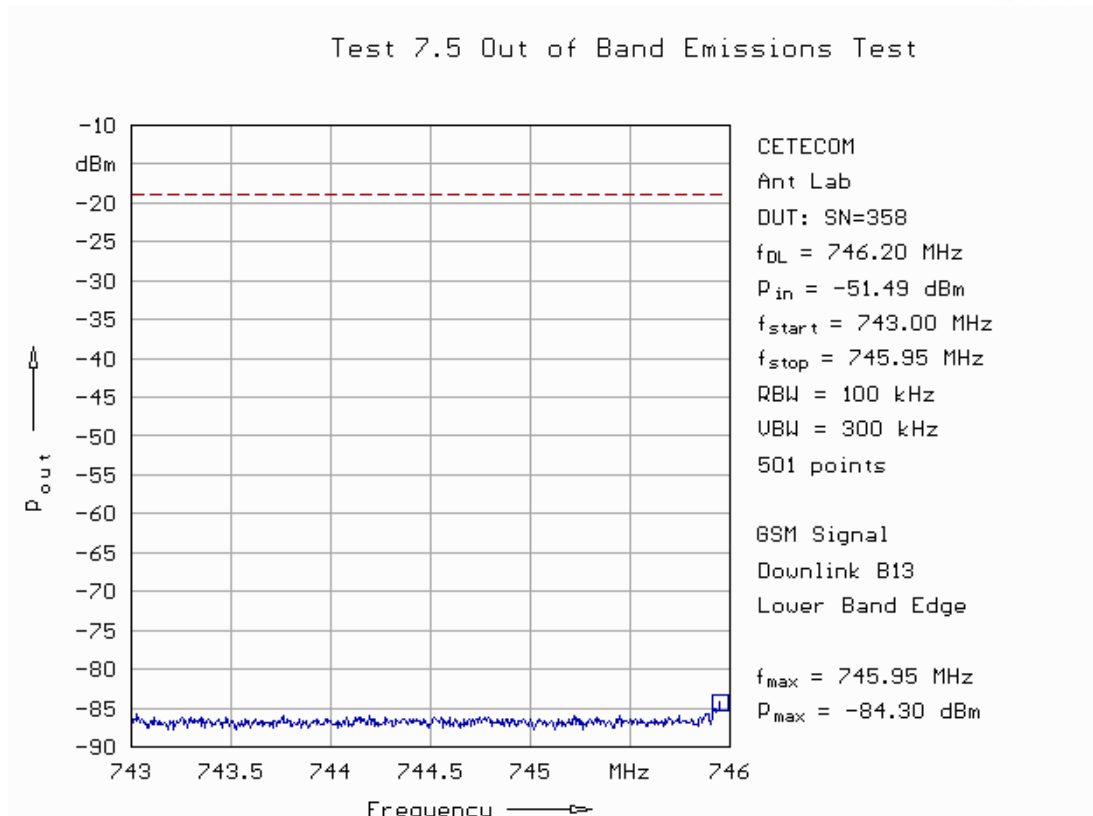

Fig. 78: Out-of-band emissions in downlink in band 13 applying a GSM signal for the lower band edge.

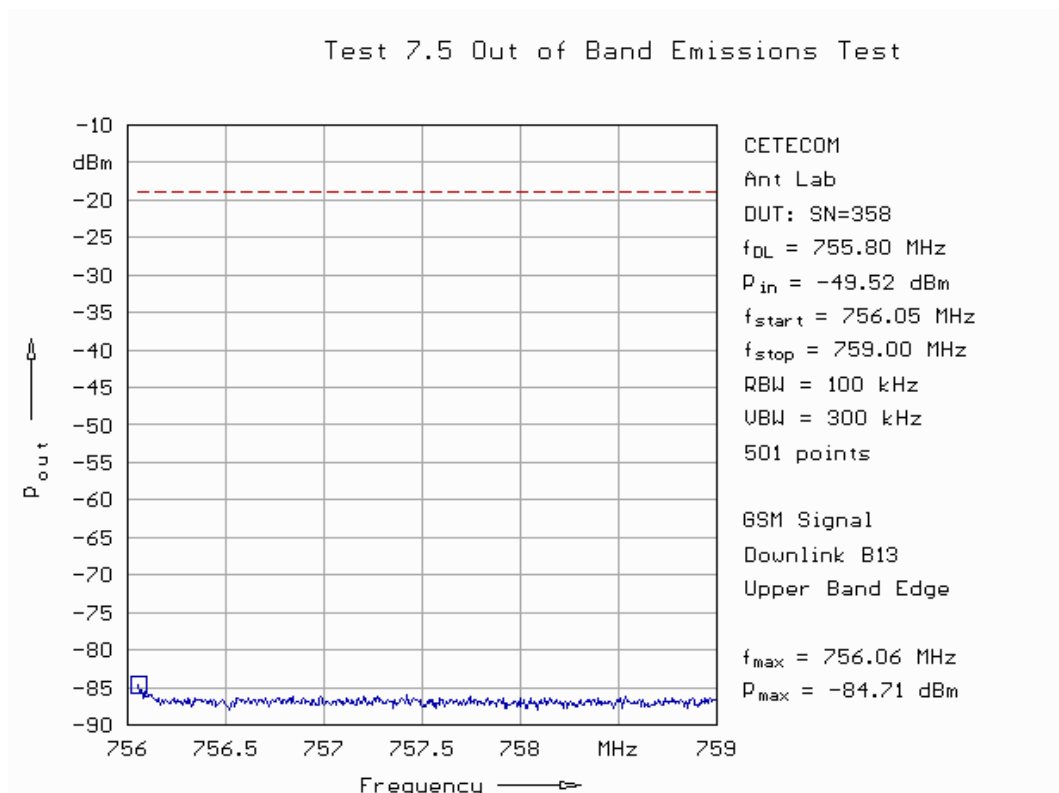

Fig. 79: Out-of-band emissions in downlink in band 13 applying a GSM signal for the upper band edge.

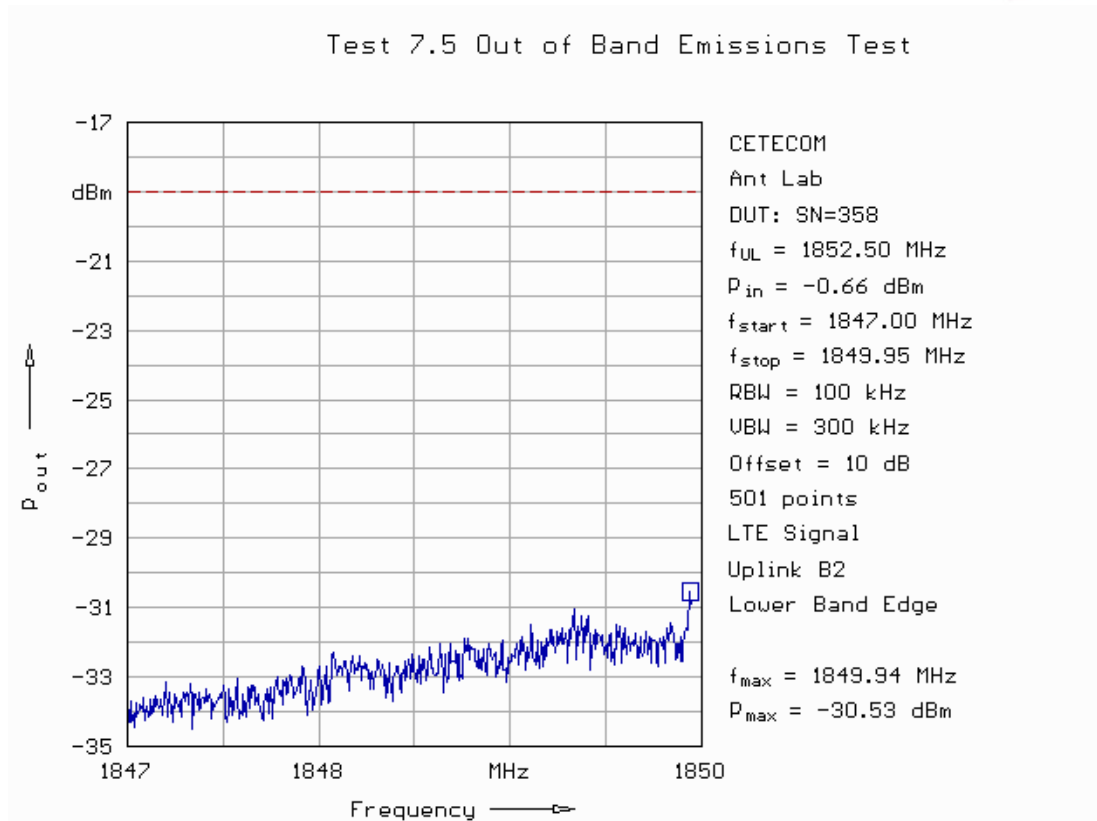

Fig. 80: Out-of-band emissions in uplink in band 2 applying a LTE signal for the lower band edge.

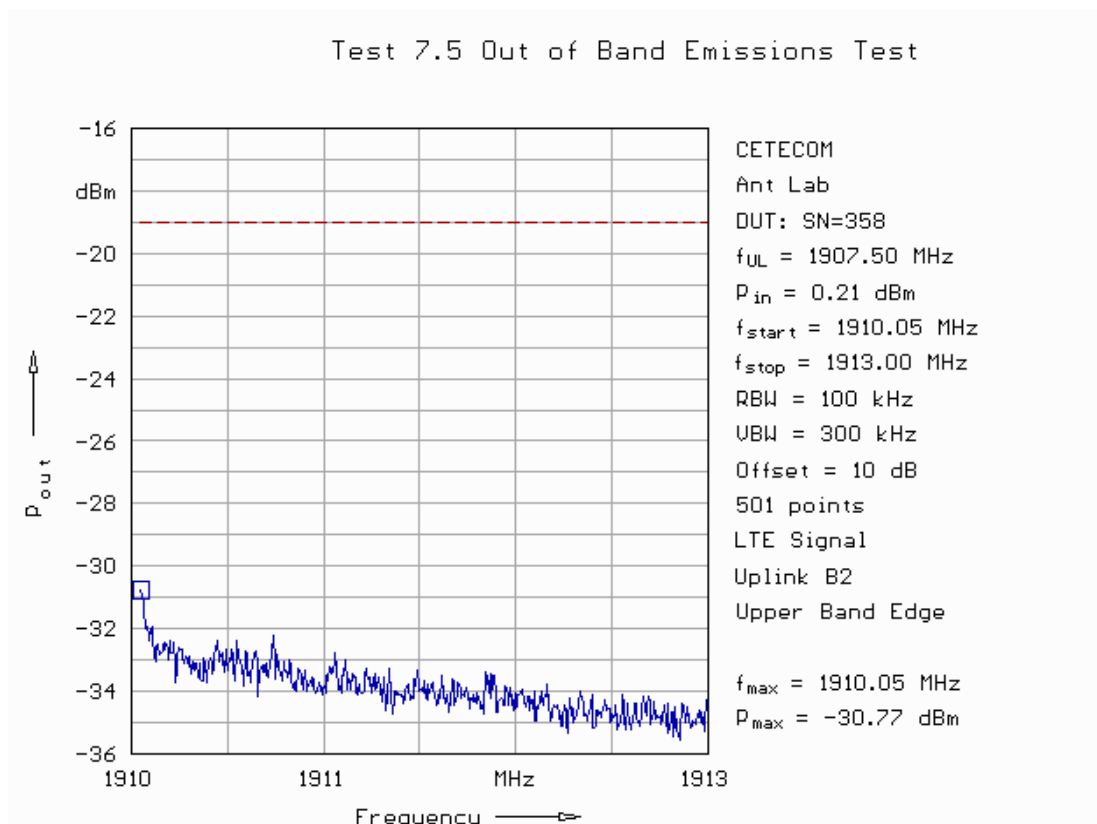

Fig. 81: Out-of-band emissions in uplink in band 2 applying a LTE signal for the upper band edge.

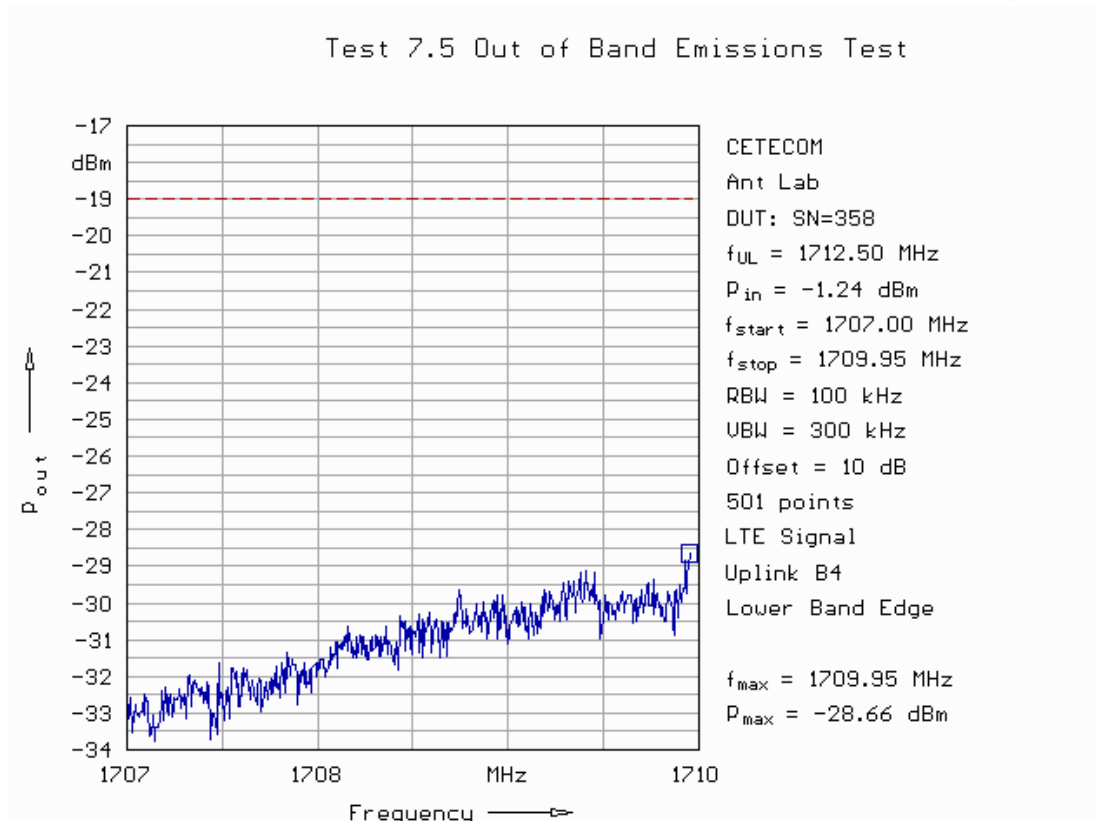

Fig. 82: Out-of-band emissions in uplink in band 4 applying a LTE signal for the lower band edge.

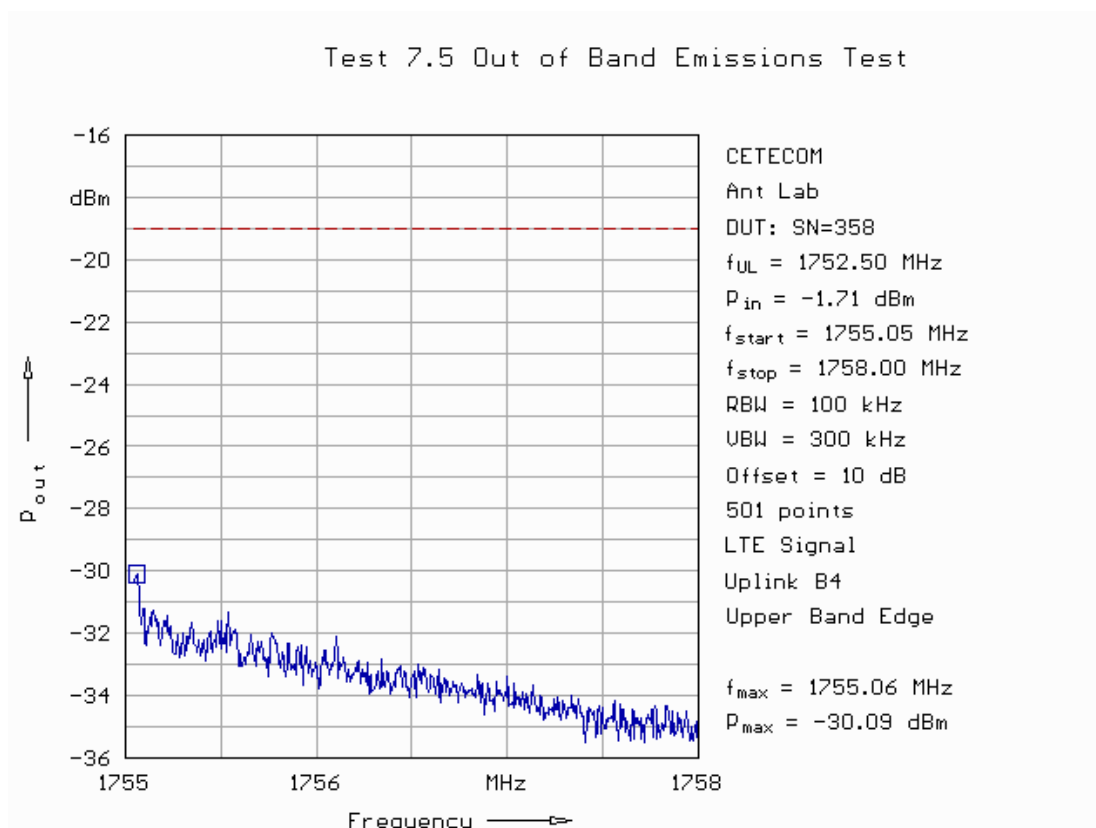

Fig. 83: Out-of-band emissions in uplink in band 4 applying a LTE signal for the upper band edge.

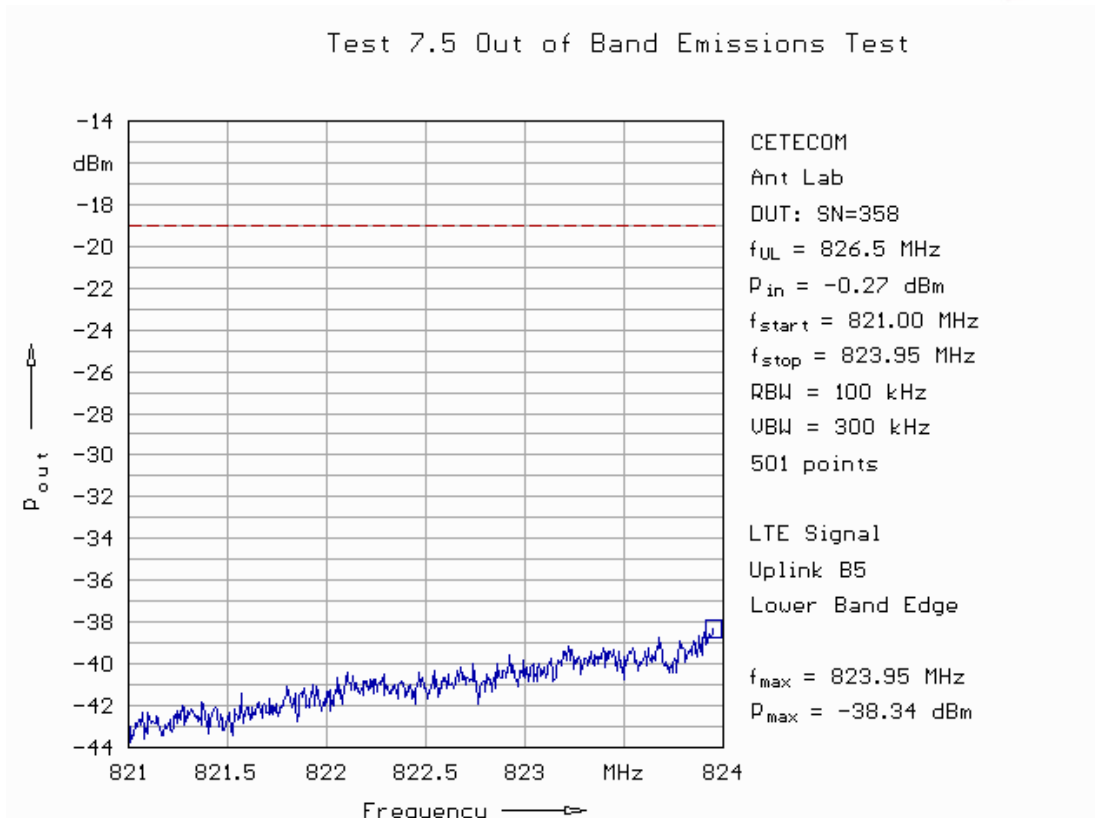

Fig. 84: Out-of-band emissions in uplink in band 5 applying a LTE signal for the lower band edge.

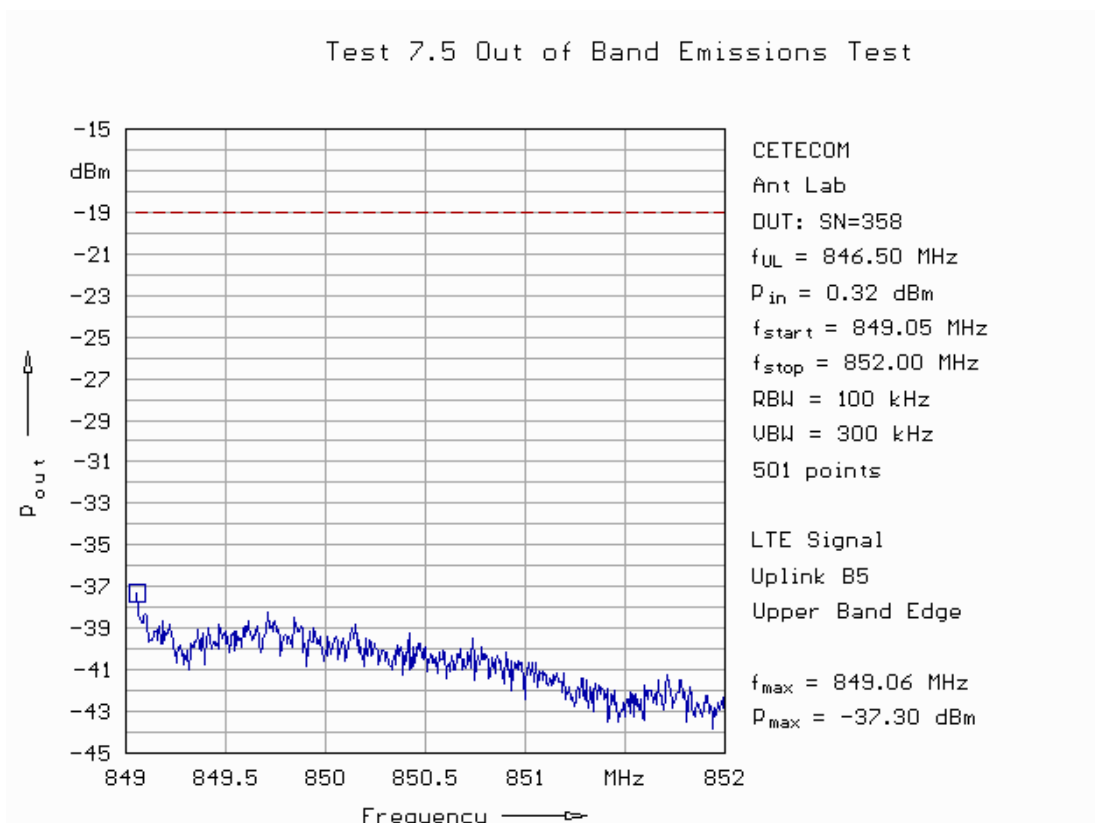

Fig. 85: Out-of-band emissions in uplink in band 5 applying a LTE signal for the upper band edge.

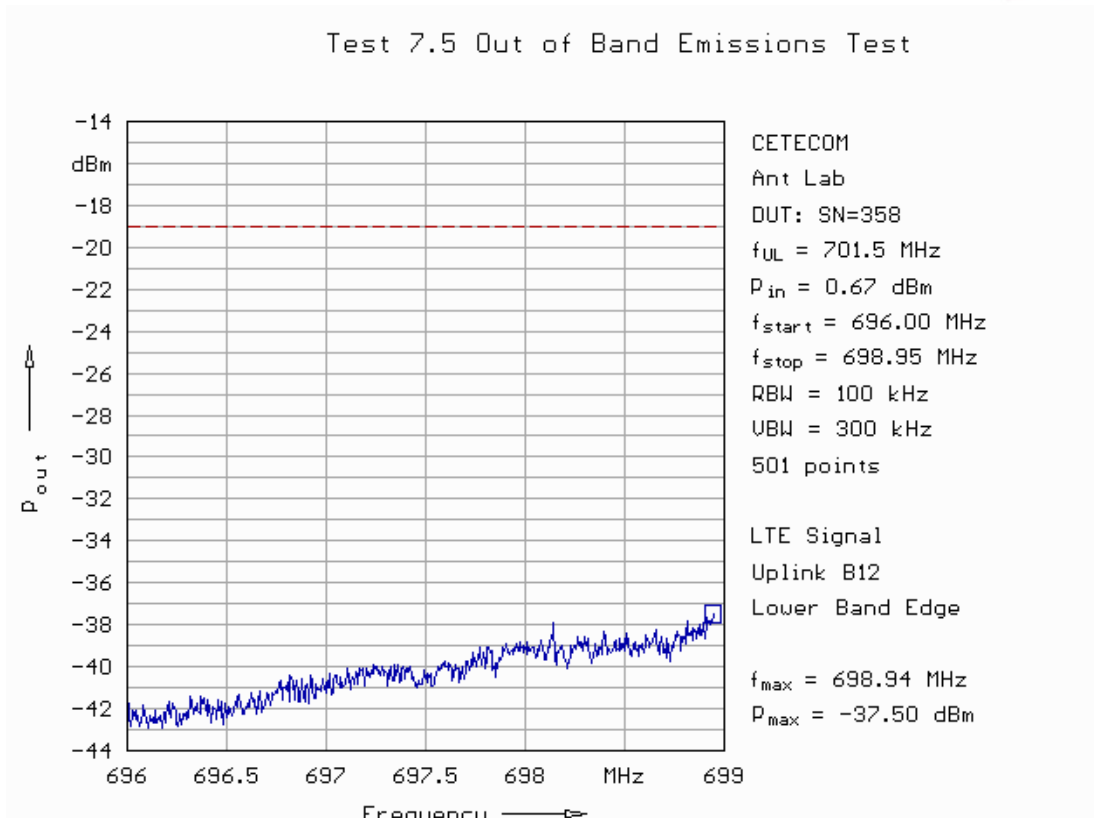

Fig. 86: Out-of-band emissions in uplink in band 12 applying a LTE signal for the lower band edge.

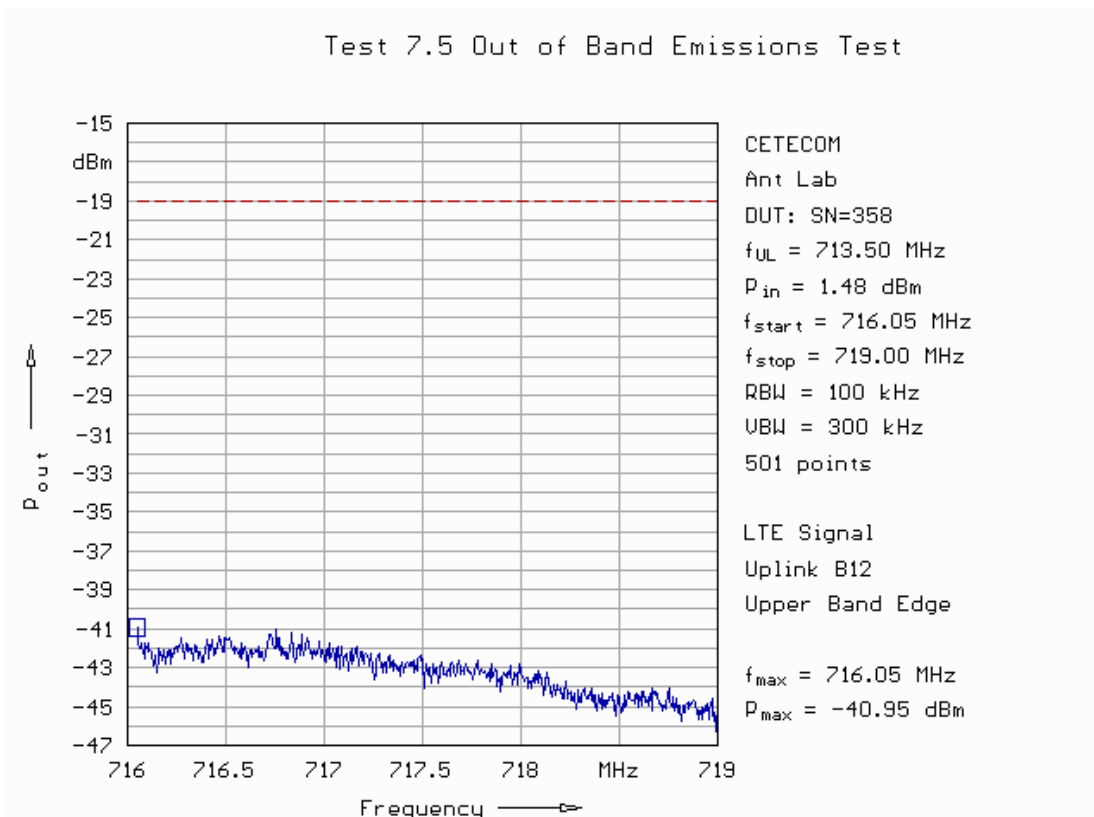

Fig. 87: Out-of-band emissions in uplink in band 12 applying a LTE signal for the upper band edge.

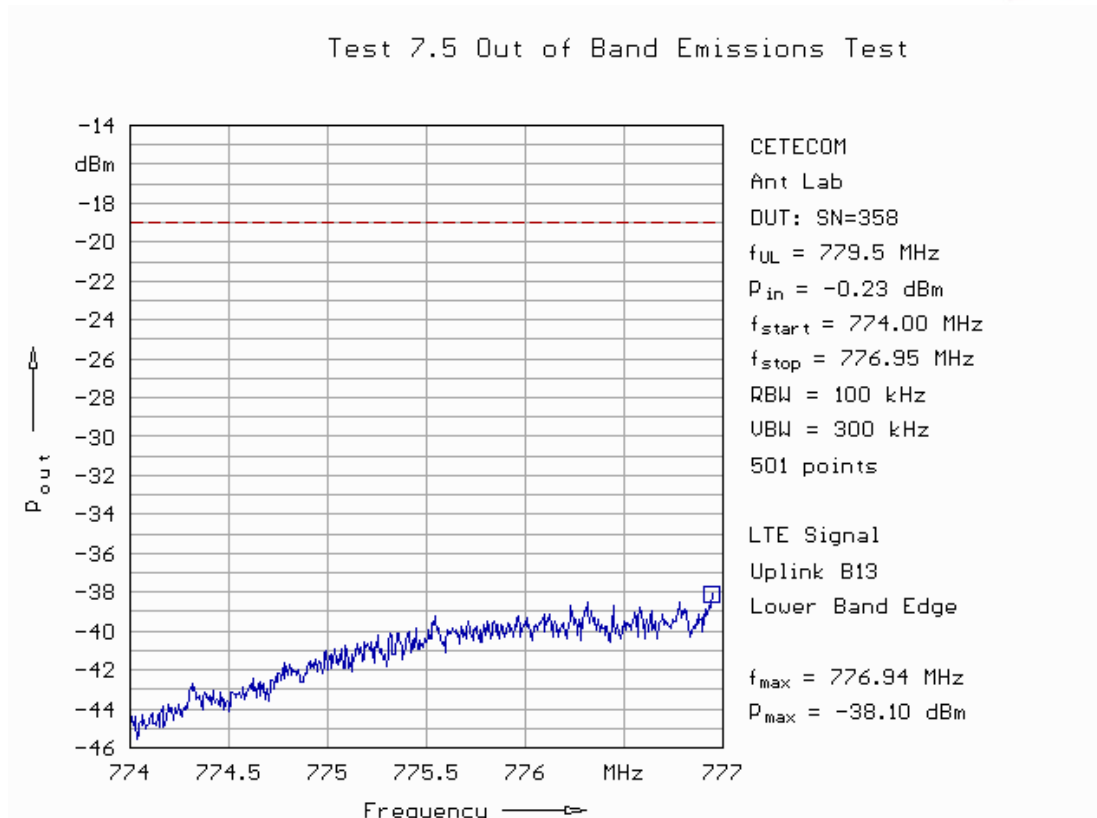

Fig. 88: Out-of-band emissions in uplink in band 13 applying a LTE signal for the lower band edge.

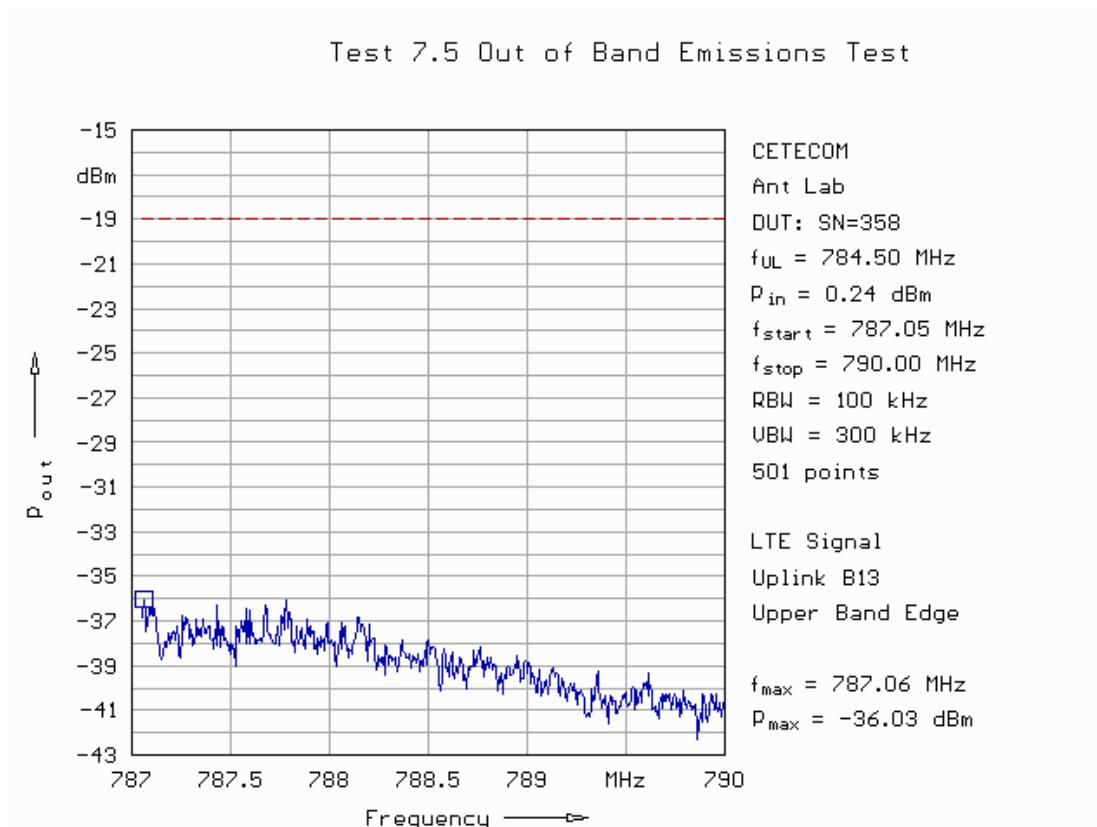

Fig. 89: Out-of-band emissions in uplink in band 13 applying a LTE signal for the upper band edge.

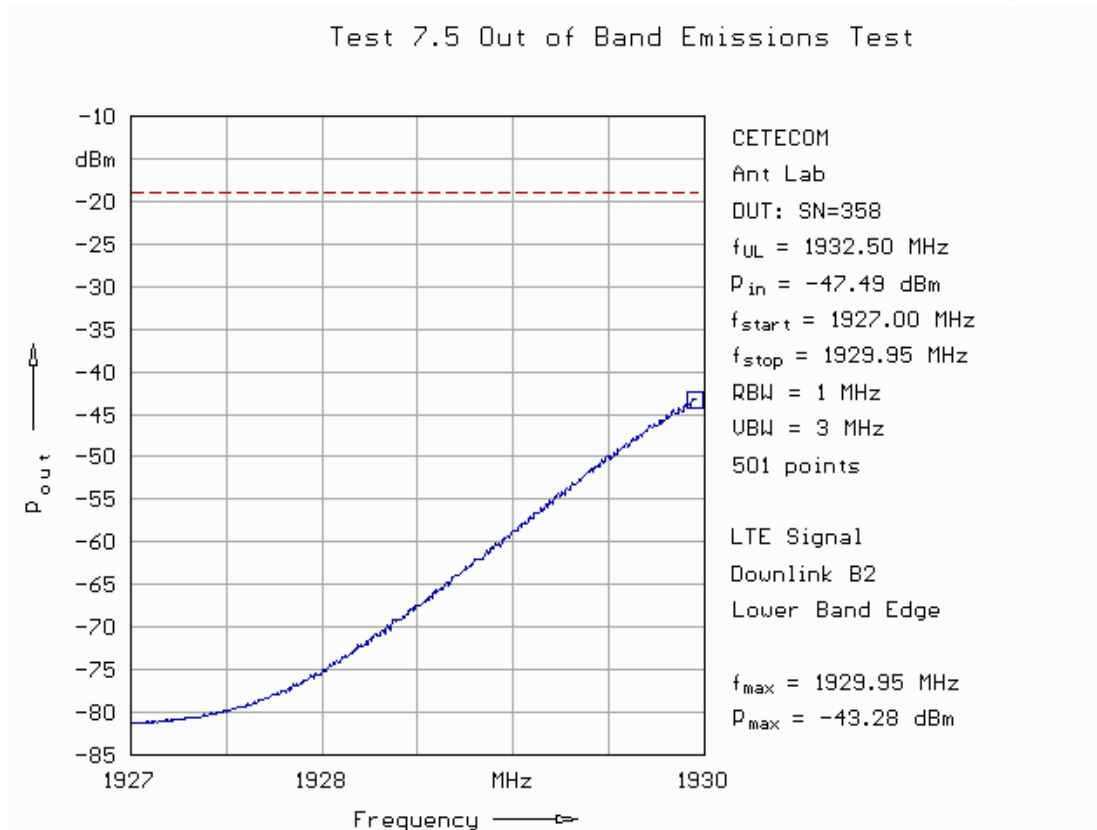

Fig. 90: Out-of-band emissions in downlink in band 2 applying a LTE signal for the lower band edge.

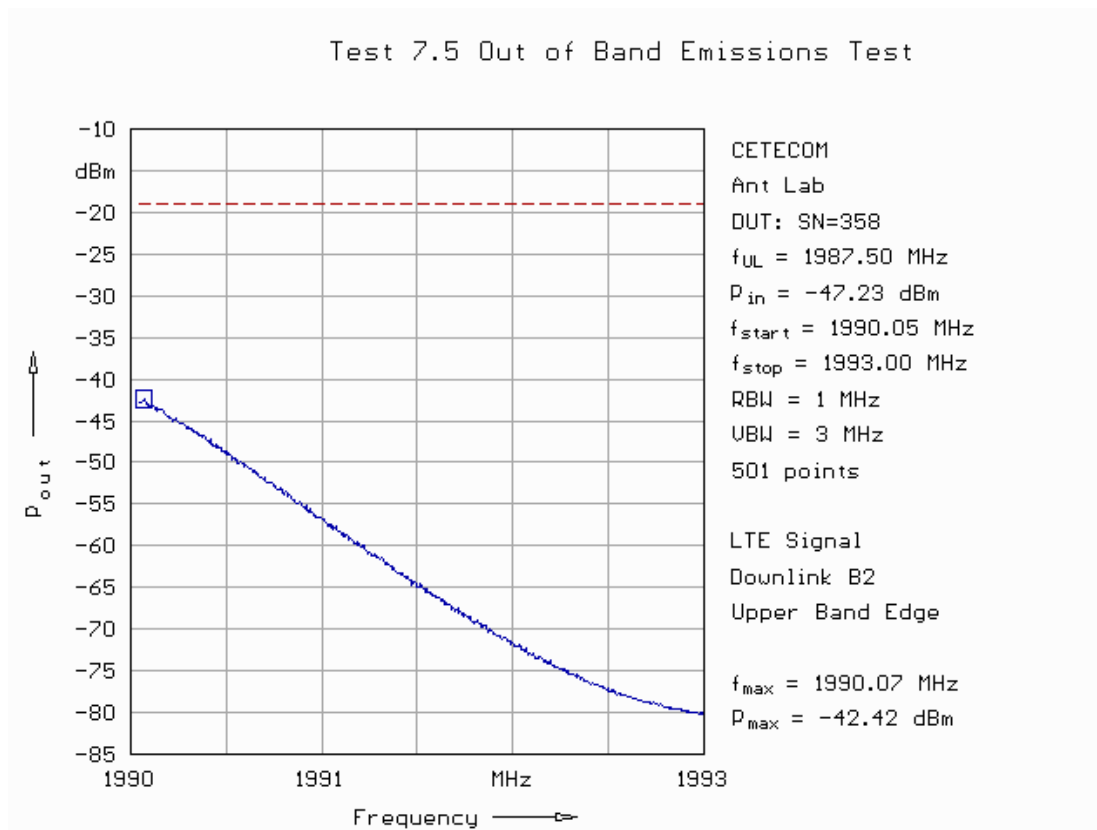

Fig. 91: Out-of-band emissions in downlink in band 2 applying a LTE signal for the upper band edge.

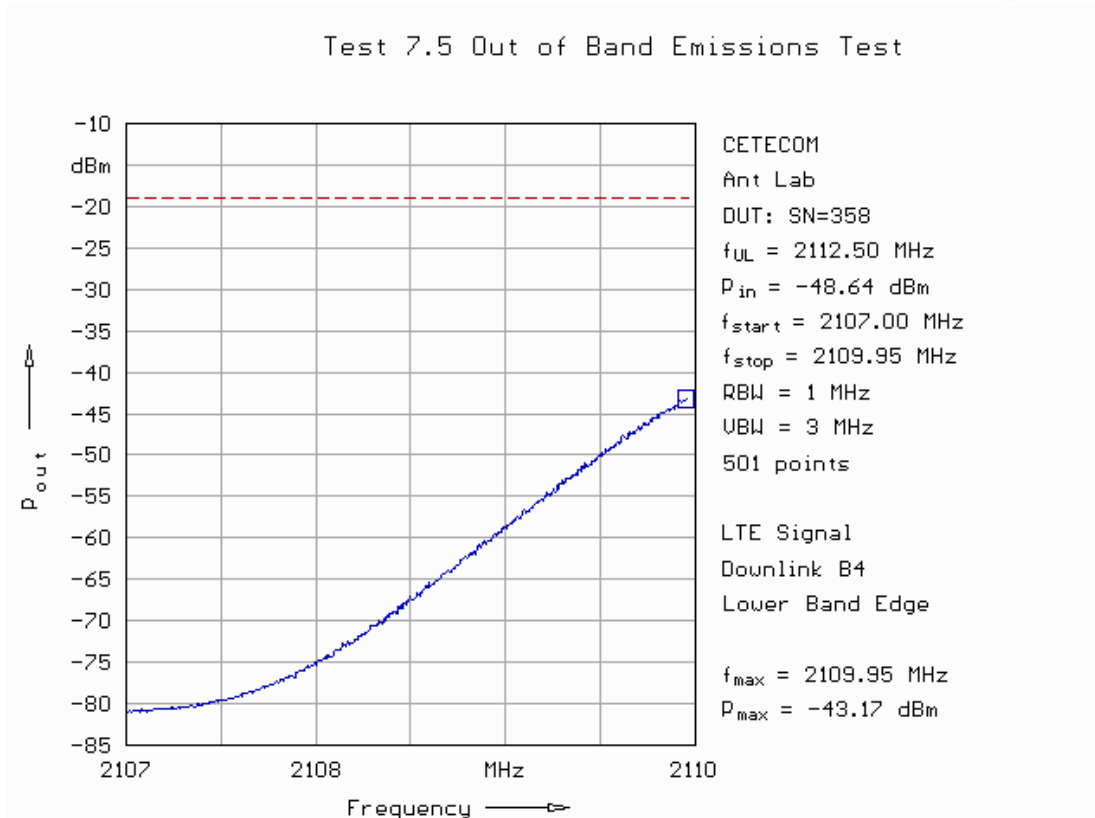

Fig. 92: Out-of-band emissions in downlink in band 4 applying a LTE signal for the lower band edge.

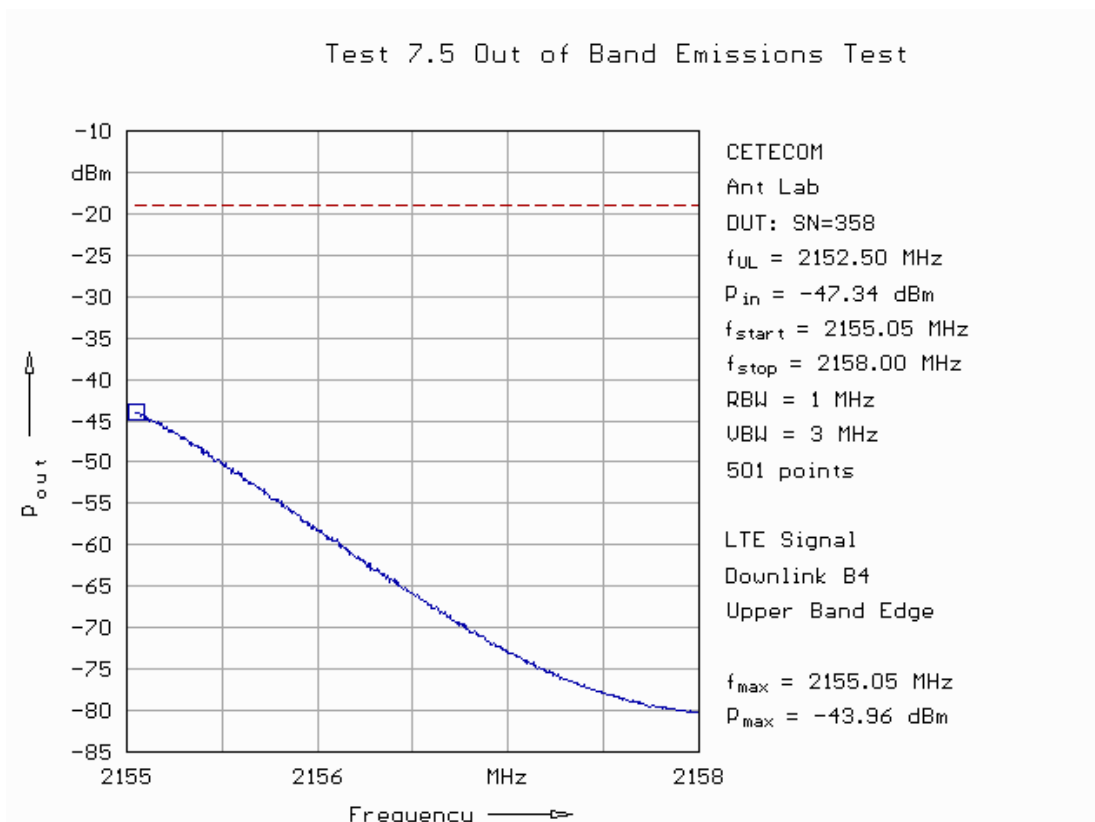

Fig. 93: Out-of-band emissions in downlink in band 4 applying a LTE signal for the upper band edge.

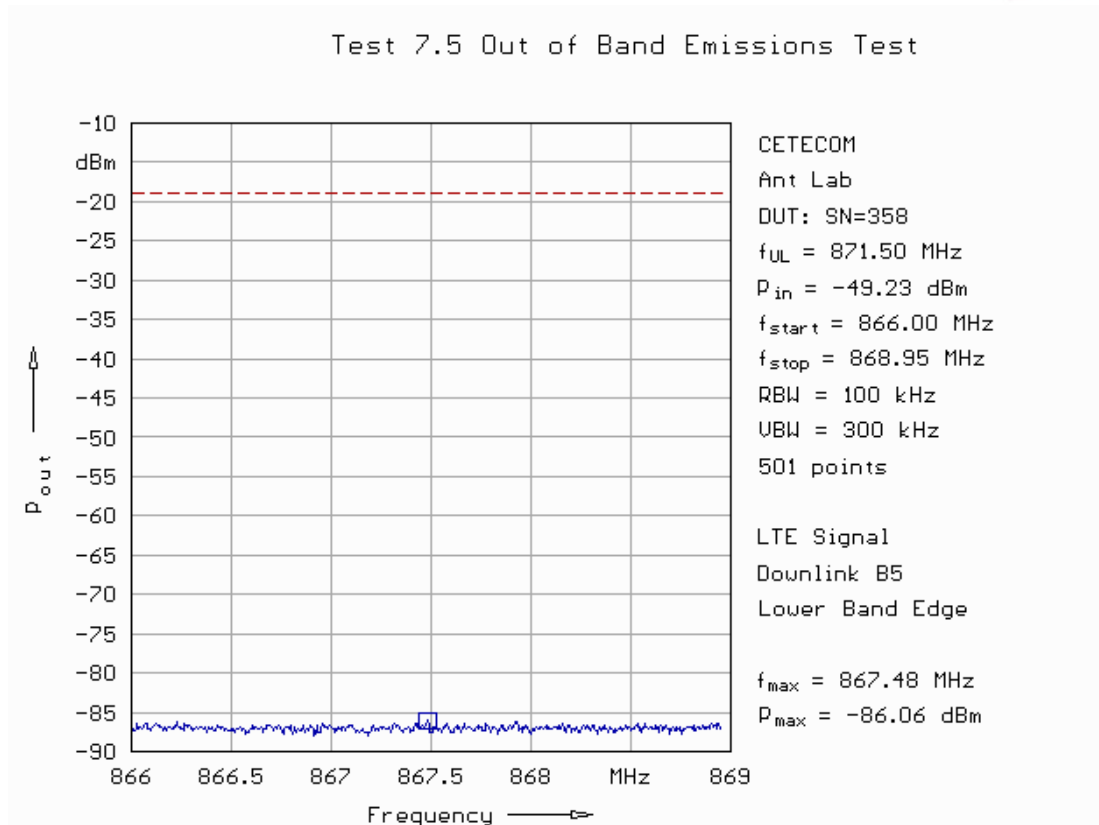

Fig. 94: Out-of-band emissions in downlink in band 5 applying a LTE signal for the lower band edge.

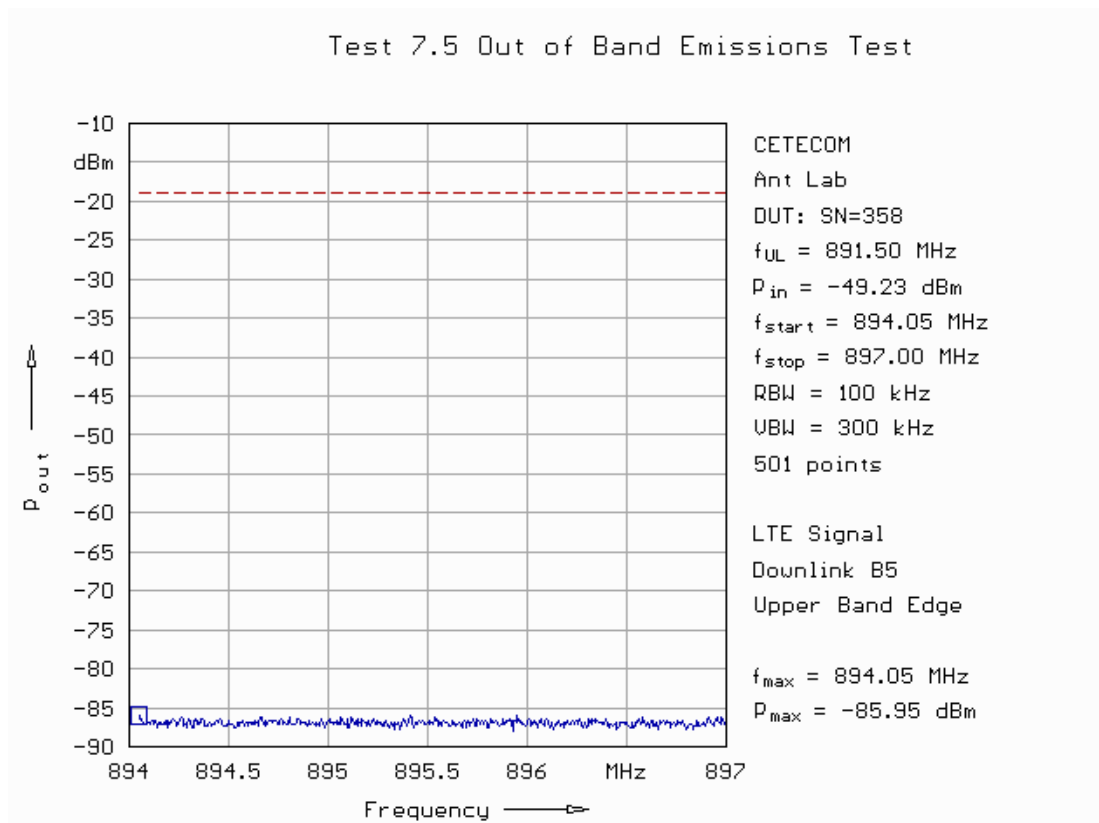

Fig. 95: Out-of-band emissions in downlink in band 5 applying a LTE signal for the upper band edge.

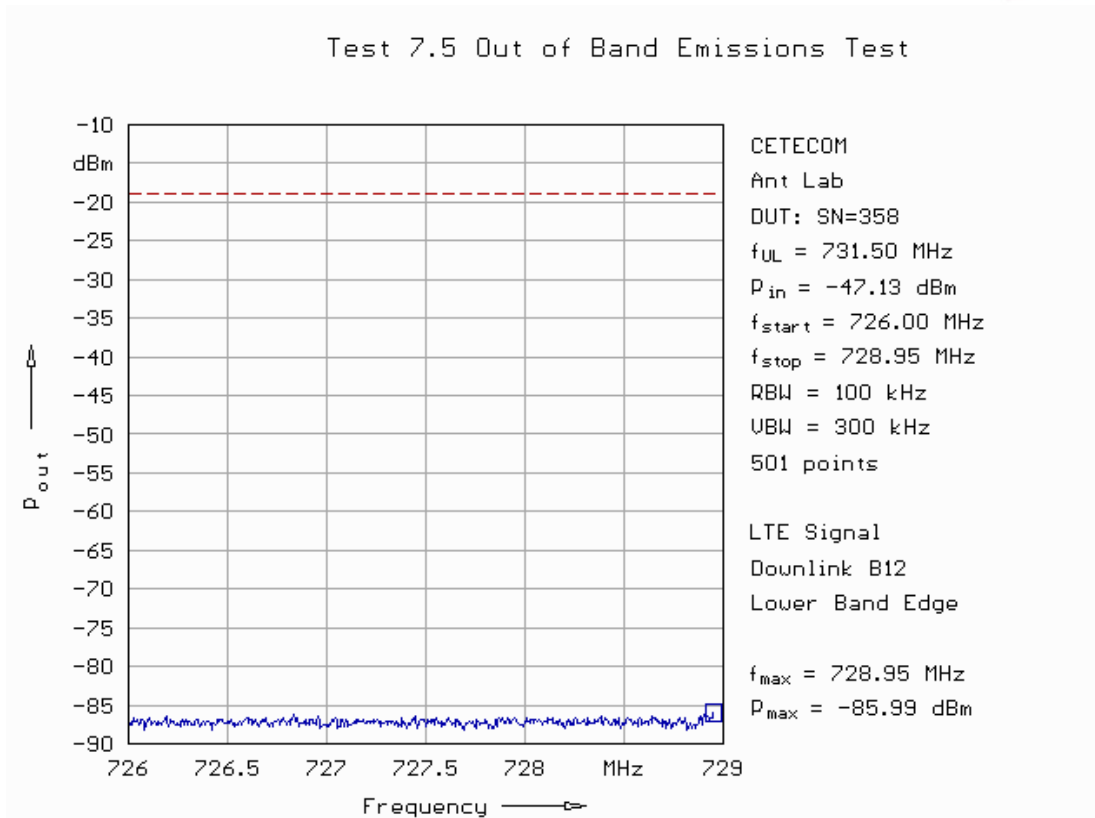

Fig. 96: Out-of-band emissions in downlink in band 12 applying a LTE signal for the lower band edge.

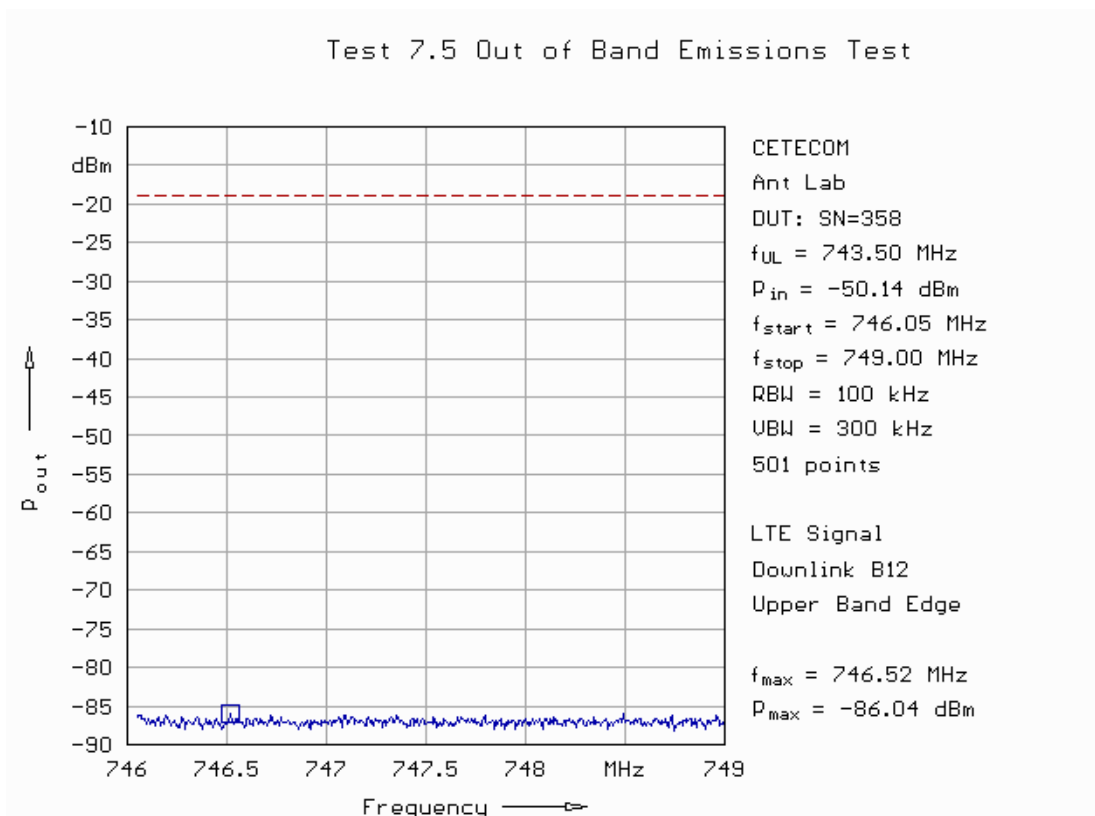

Fig. 97: Out-of-band emissions in downlink in band 12 applying a LTE signal for the upper band edge.

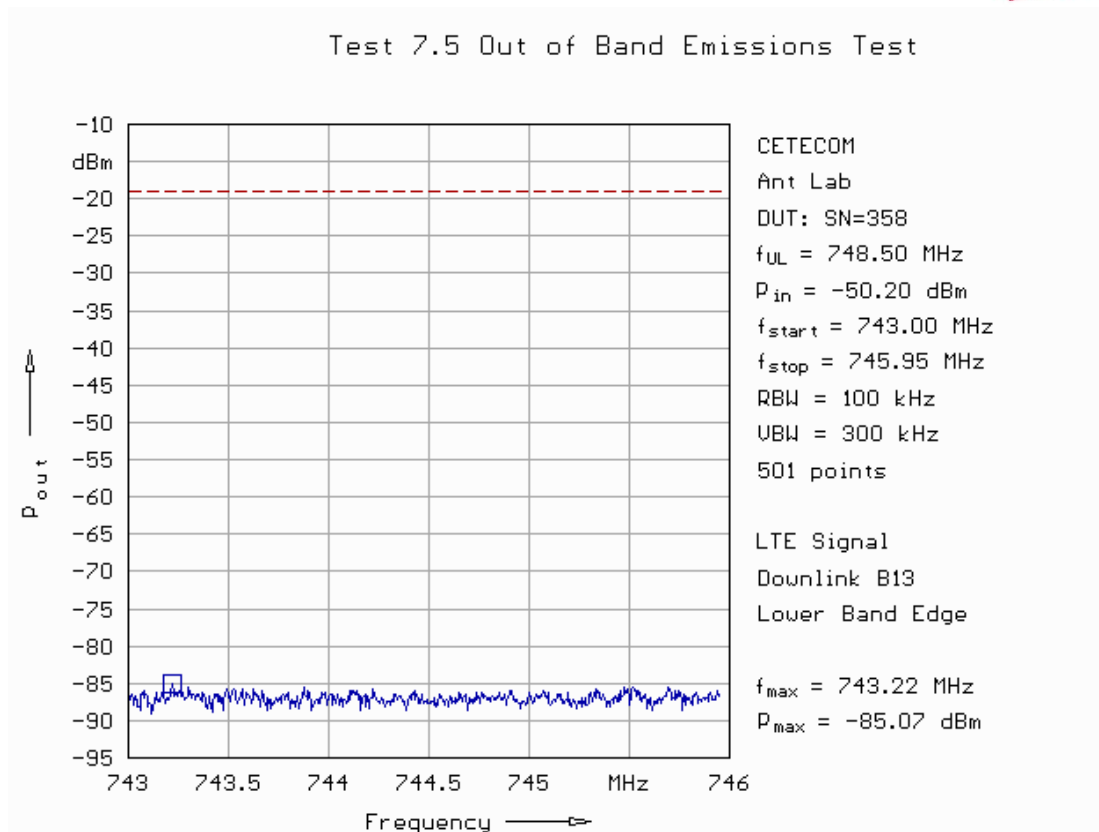

Fig. 98: Out-of-band emissions in downlink in band 13 applying a LTE signal for the lower band edge.

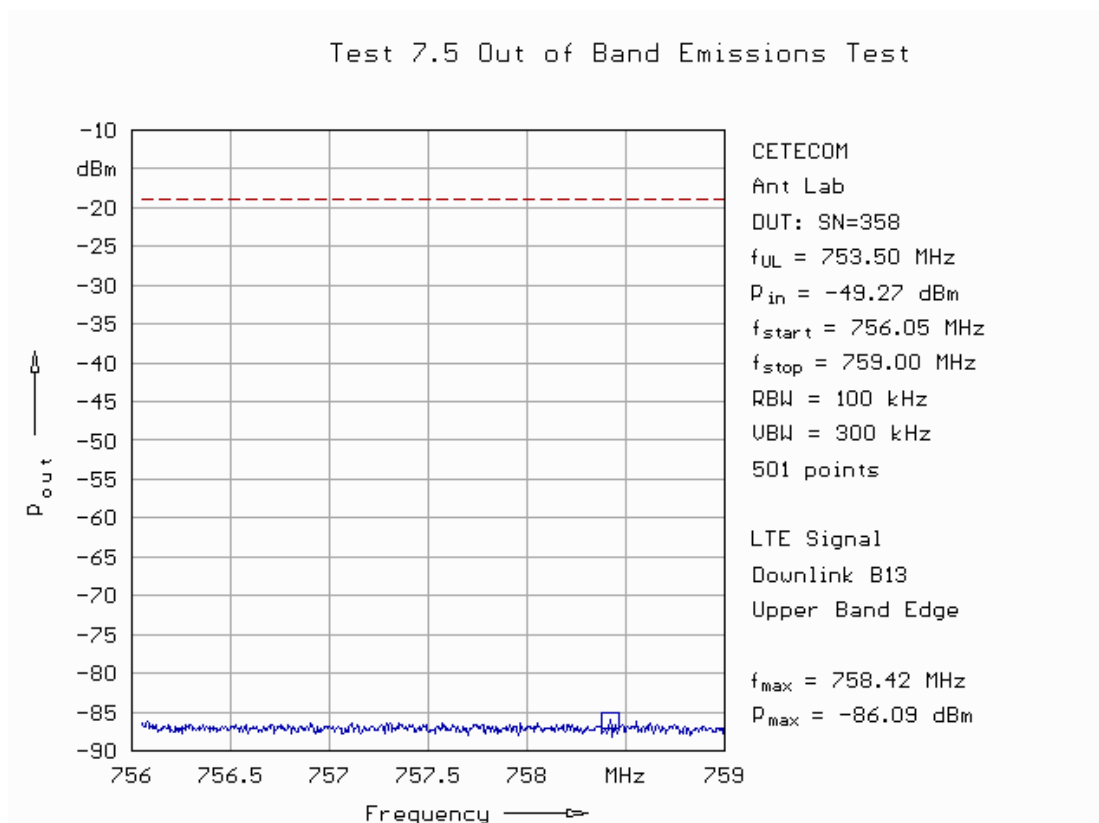

Fig. 99: Out-of-band emissions in downlink in band 13 applying a LTE signal for the upper band edge.

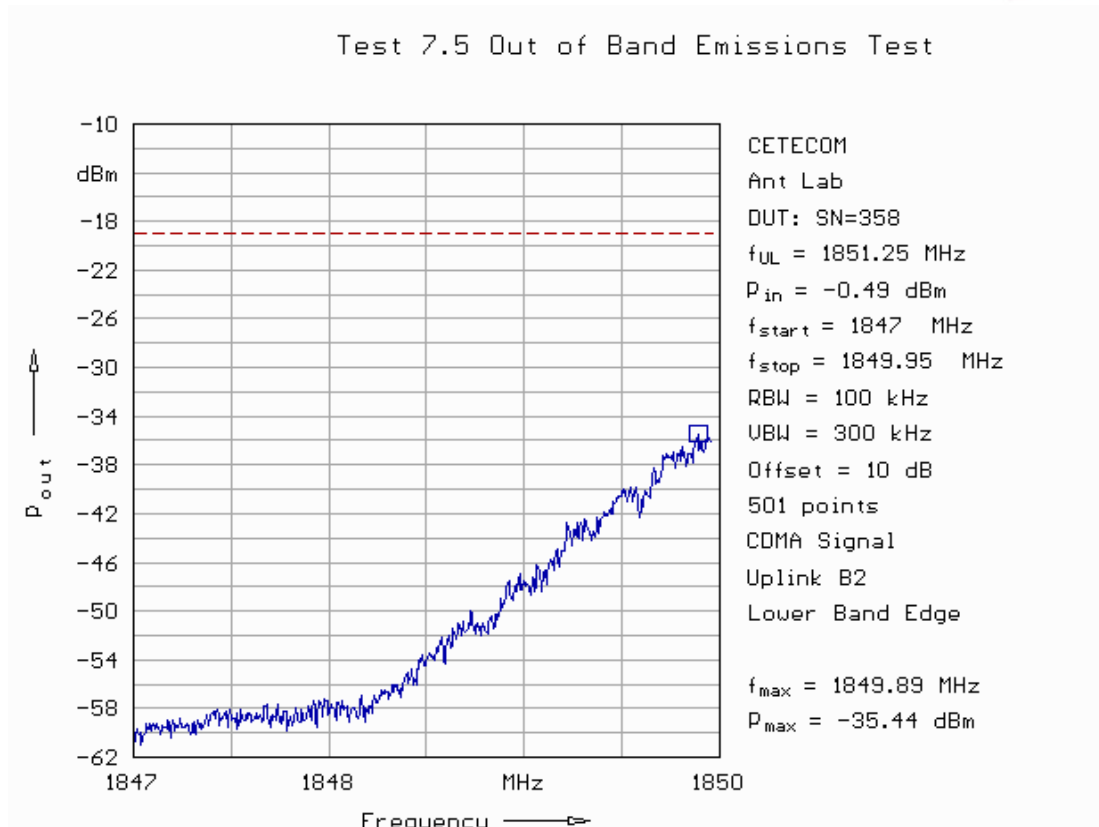

Fig. 100: Out-of-band emissions in uplink in band 2 applying a CDMA signal for the lower band edge.

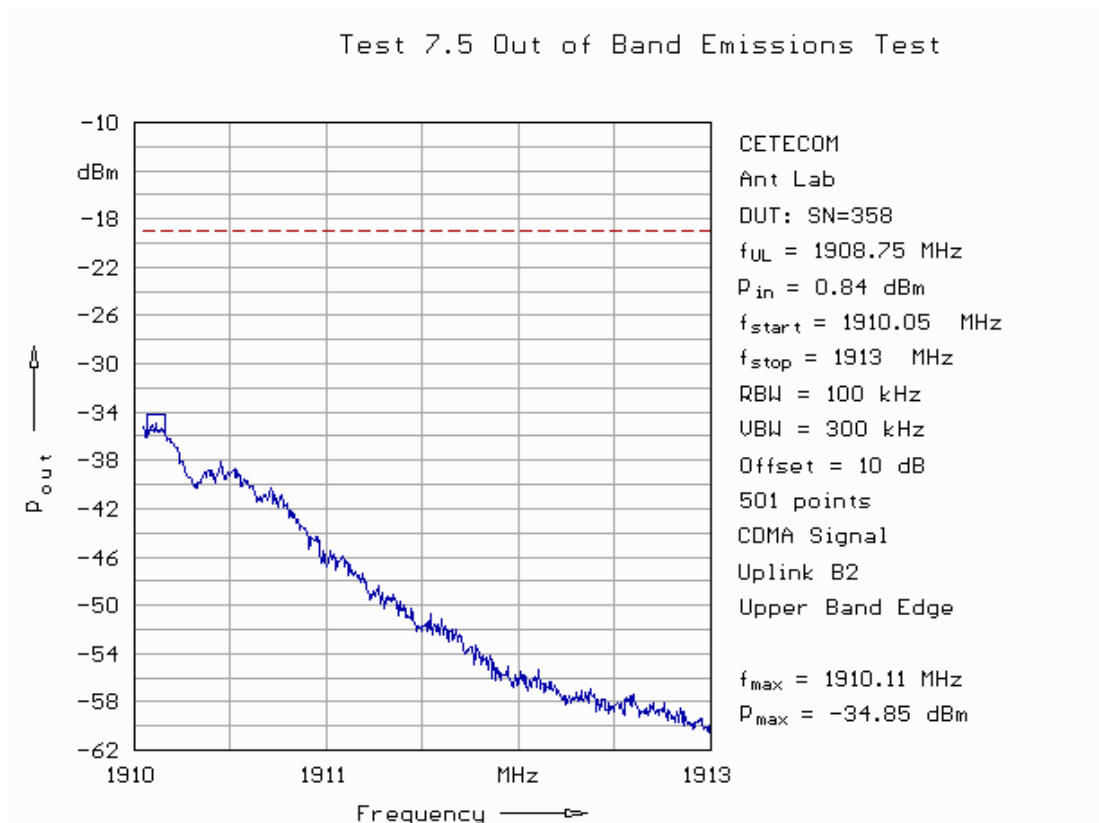

Fig. 101: Out-of-band emissions in uplink in band 2 applying a CDMA signal for the upper band edge.

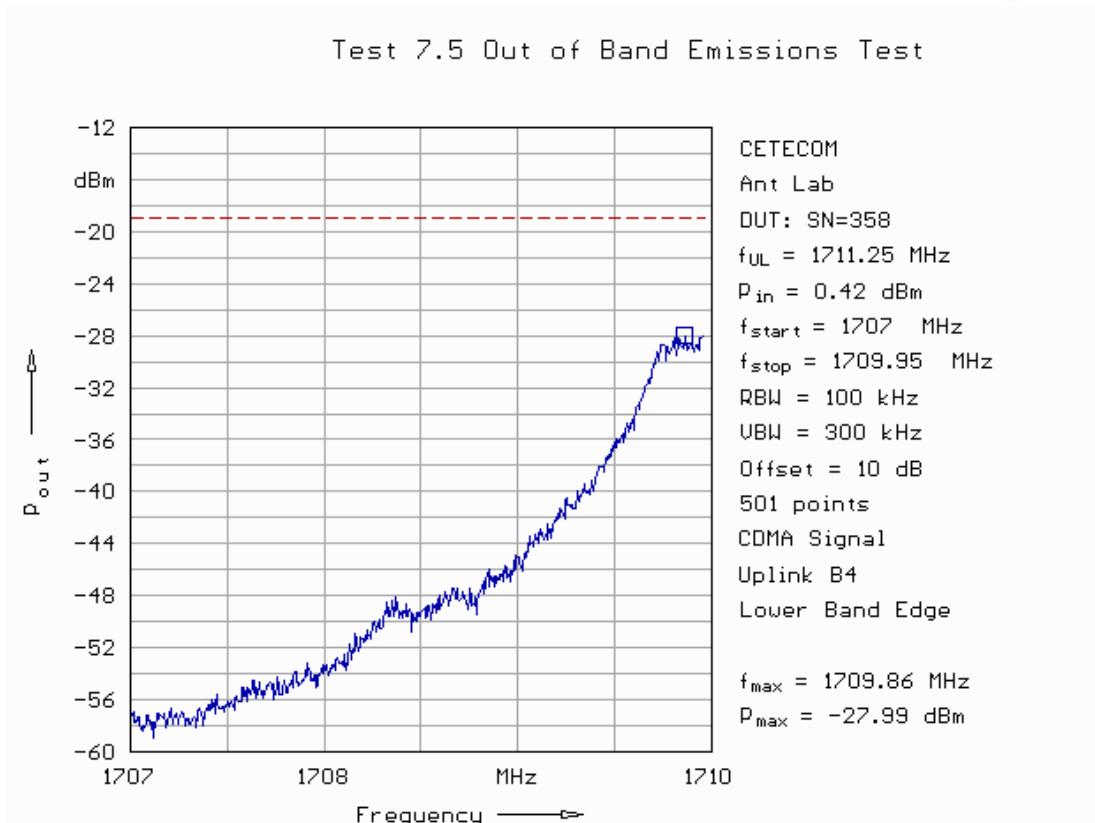

Fig. 102: Out-of-band emissions in uplink in band 4 applying a CDMA signal for the lower band edge.

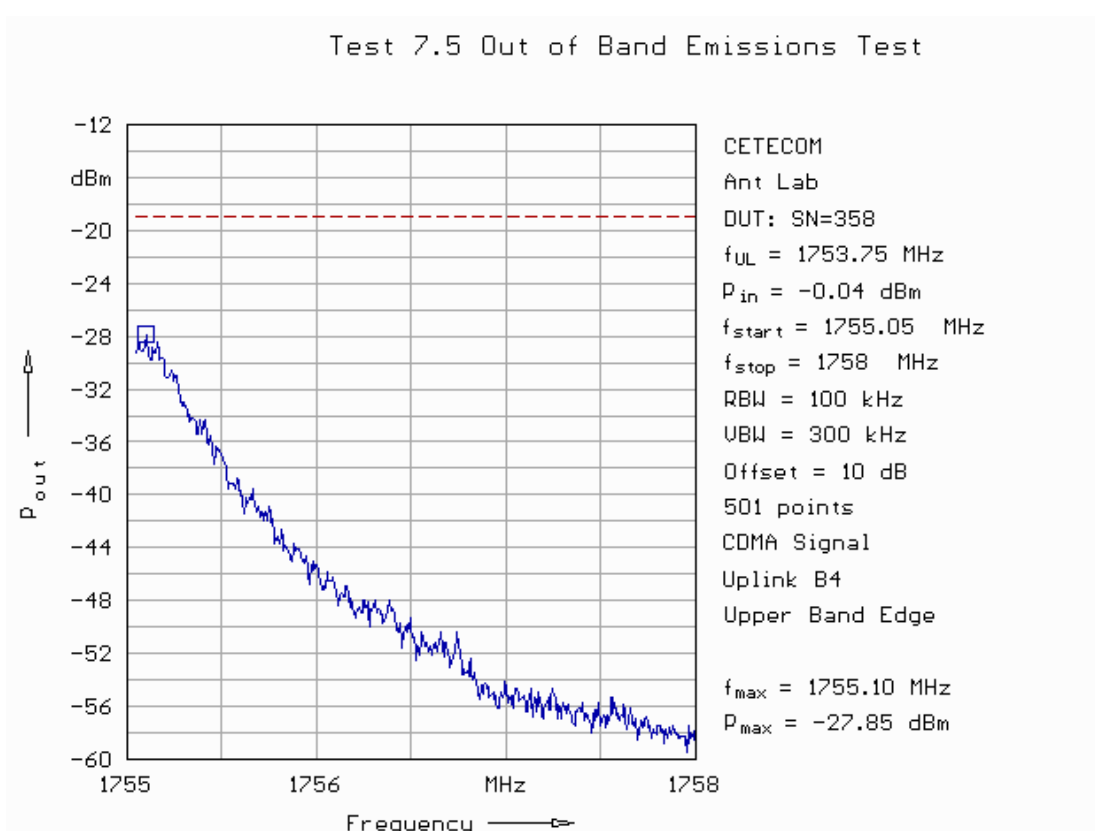

Fig. 103: Out-of-band emissions in uplink in band 4 applying a CDMA signal for the upper band edge.

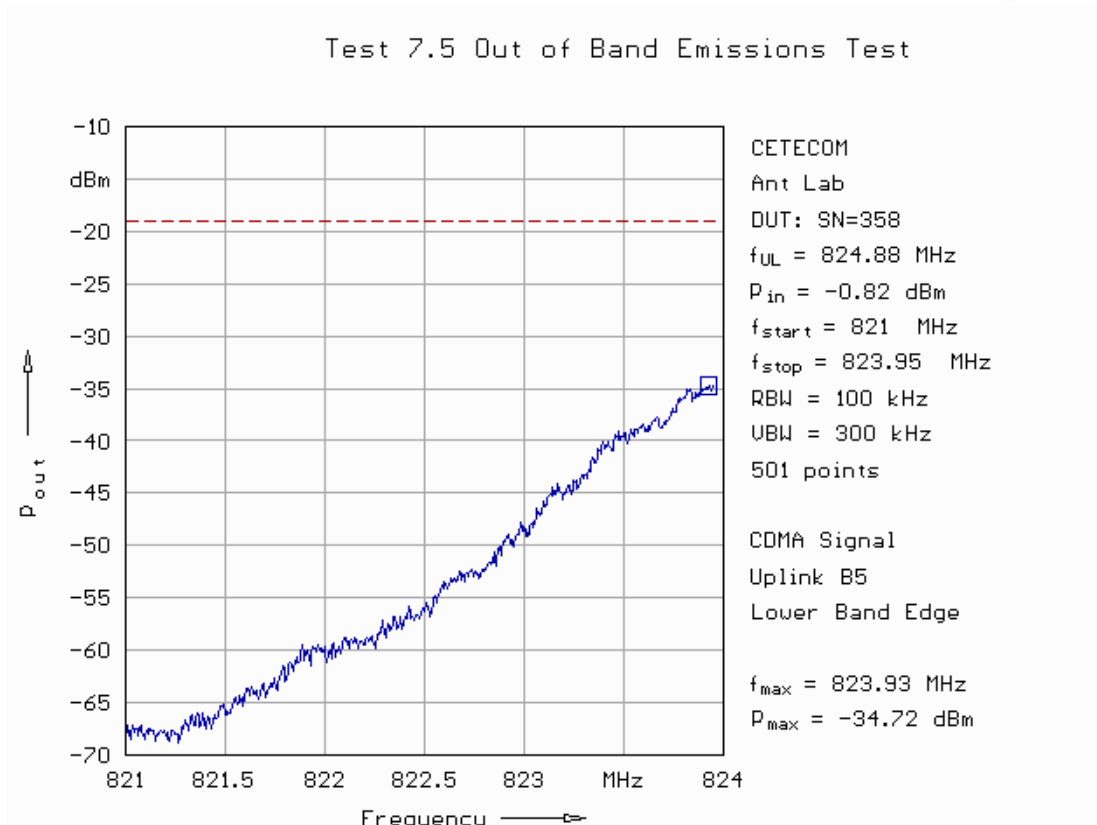

Fig. 104: Out-of-band emissions in uplink in band 5 applying a CDMA signal for the lower band edge.

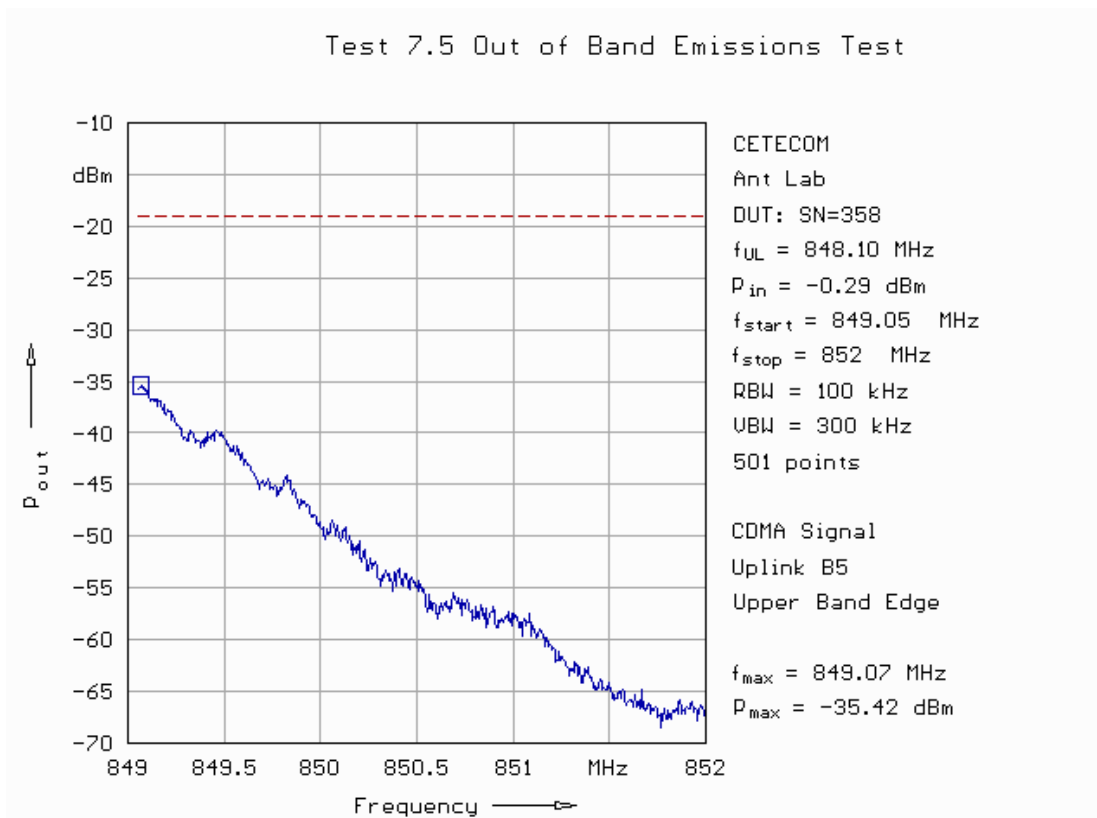

Fig. 105: Out-of-band emissions in uplink in band 5 applying a CDMA signal for the upper band edge.

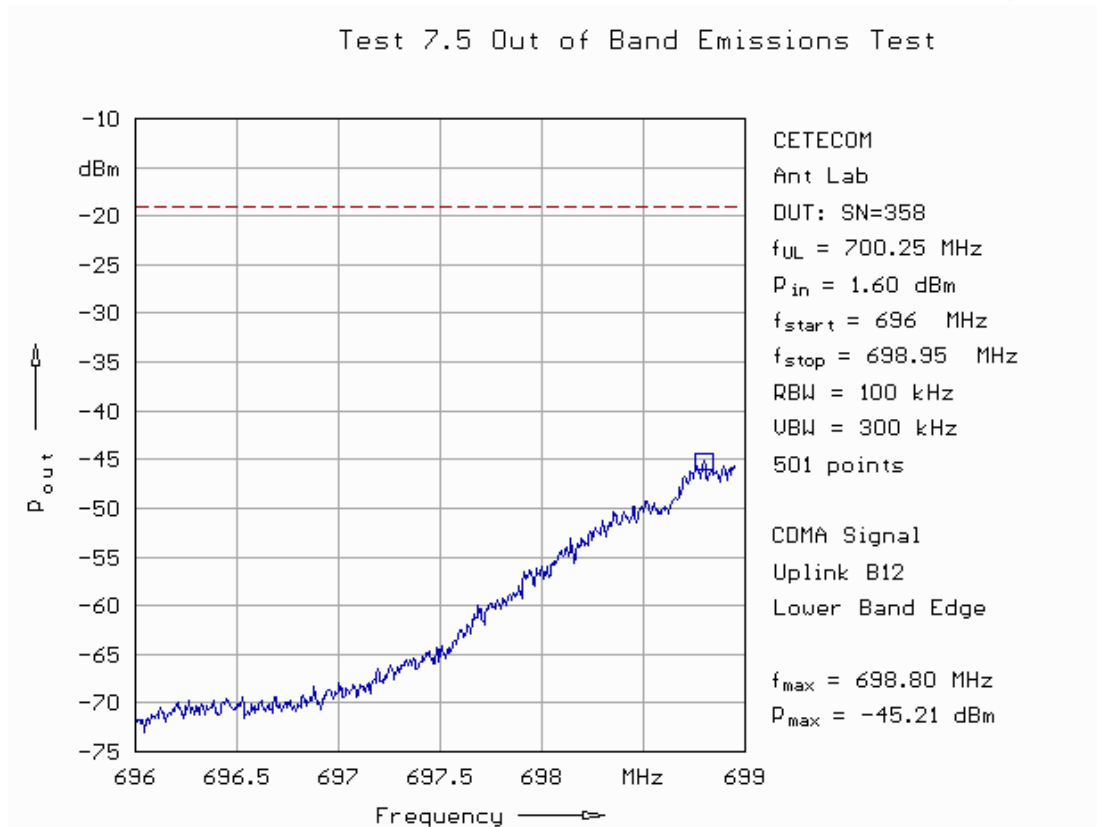

Fig. 106: Out-of-band emissions in uplink in band 12 applying a CDMA signal for the lower band edge.

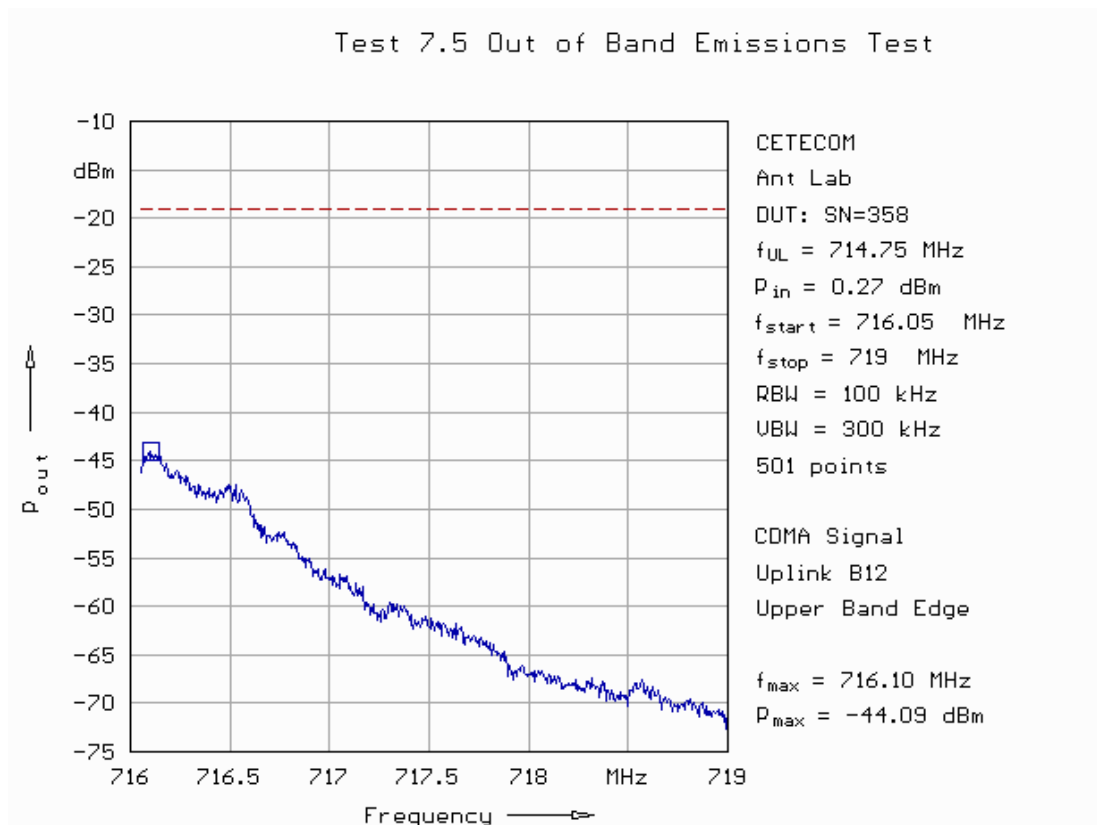

Fig. 107: Out-of-band emissions in uplink in band 12 applying a CDMA signal for the upper band edge.

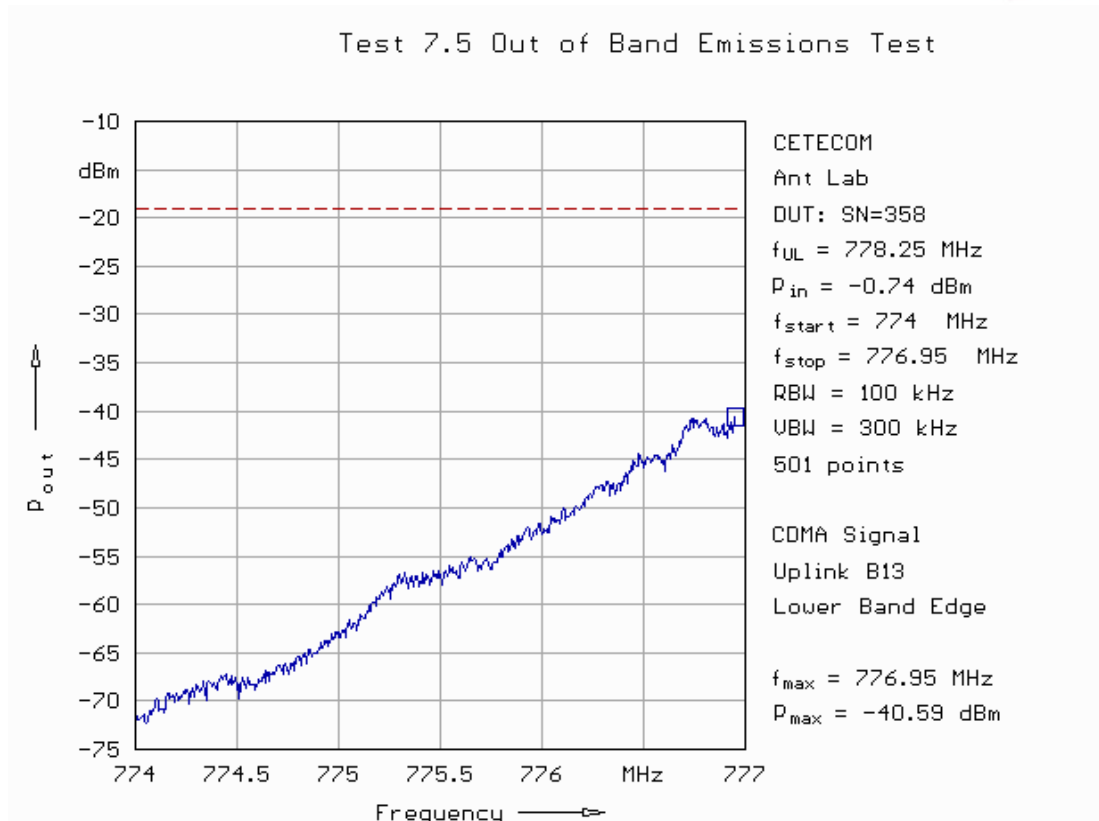

Fig. 108: Out-of-band emissions in uplink in band 13 applying a CDMA signal for the lower band edge.

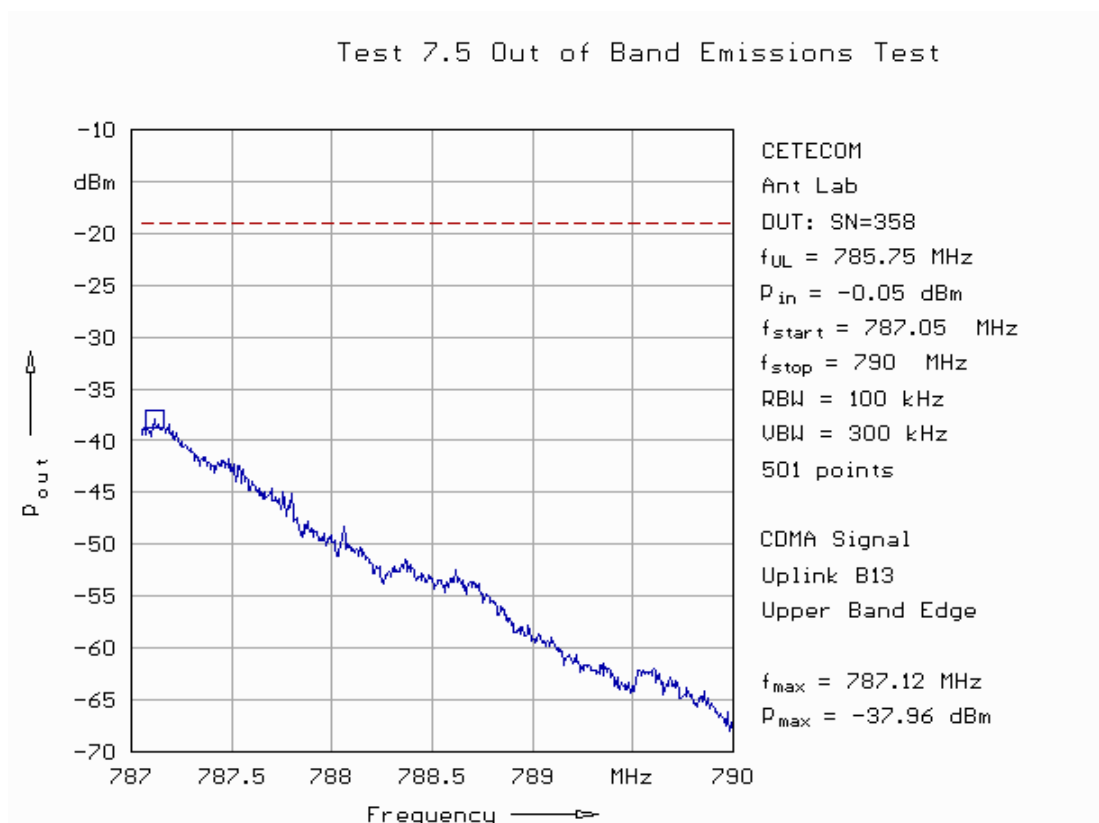

Fig. 109: Out-of-band emissions in uplink in band 13 applying a CDMA signal for the upper band edge.

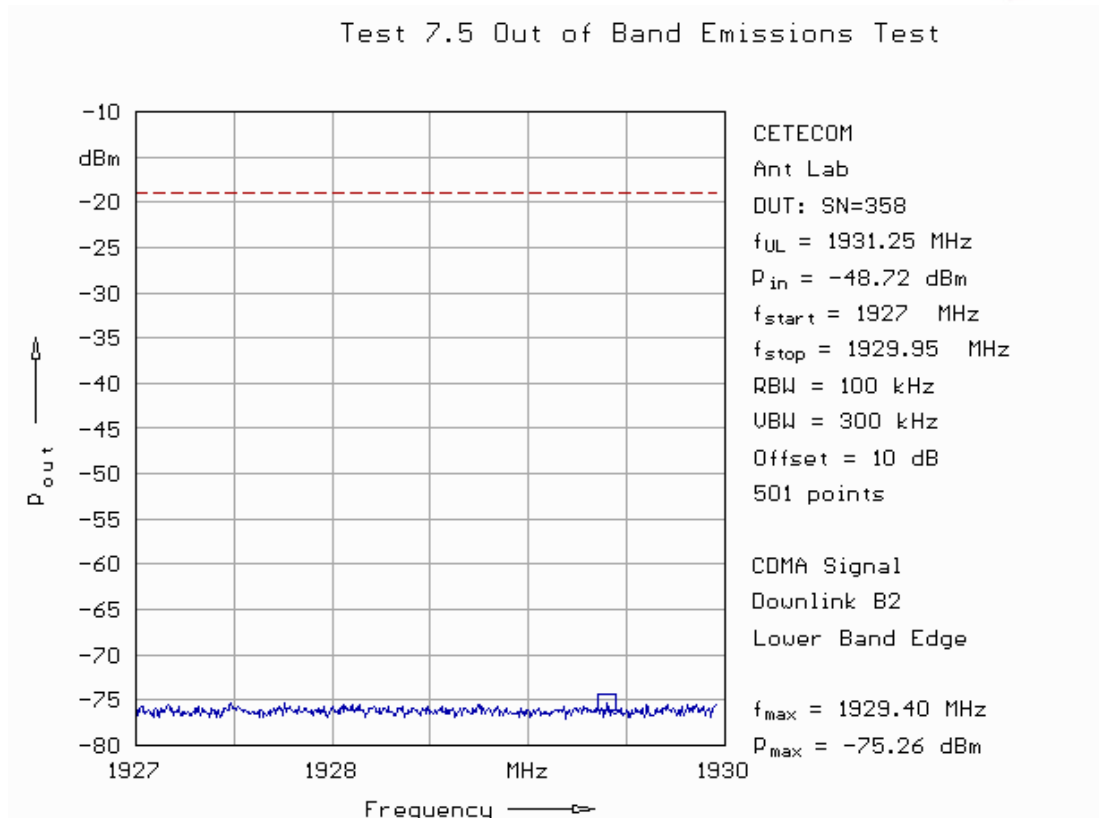

Fig. 110: Out-of-band emissions in downlink in band 2 applying a CDMA signal for the lower band edge.

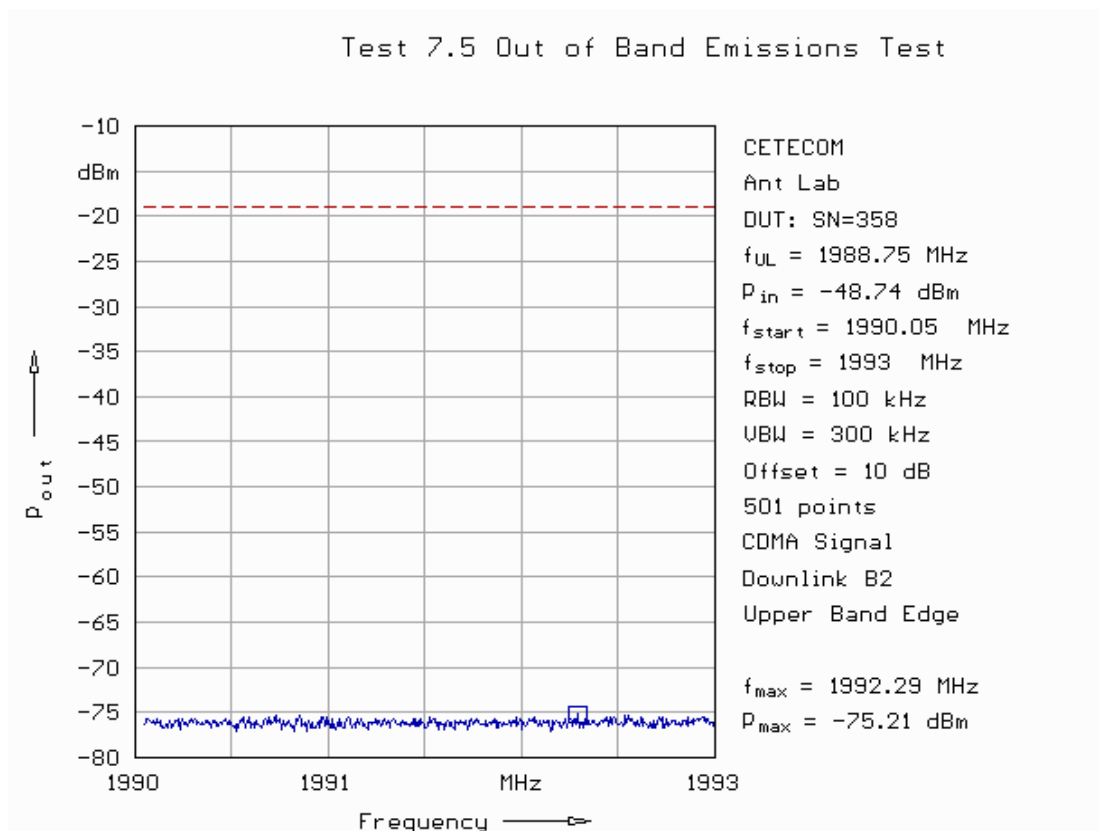

Fig. 111: Out-of-band emissions in downlink in band 2 applying a CDMA signal for the upper band edge.

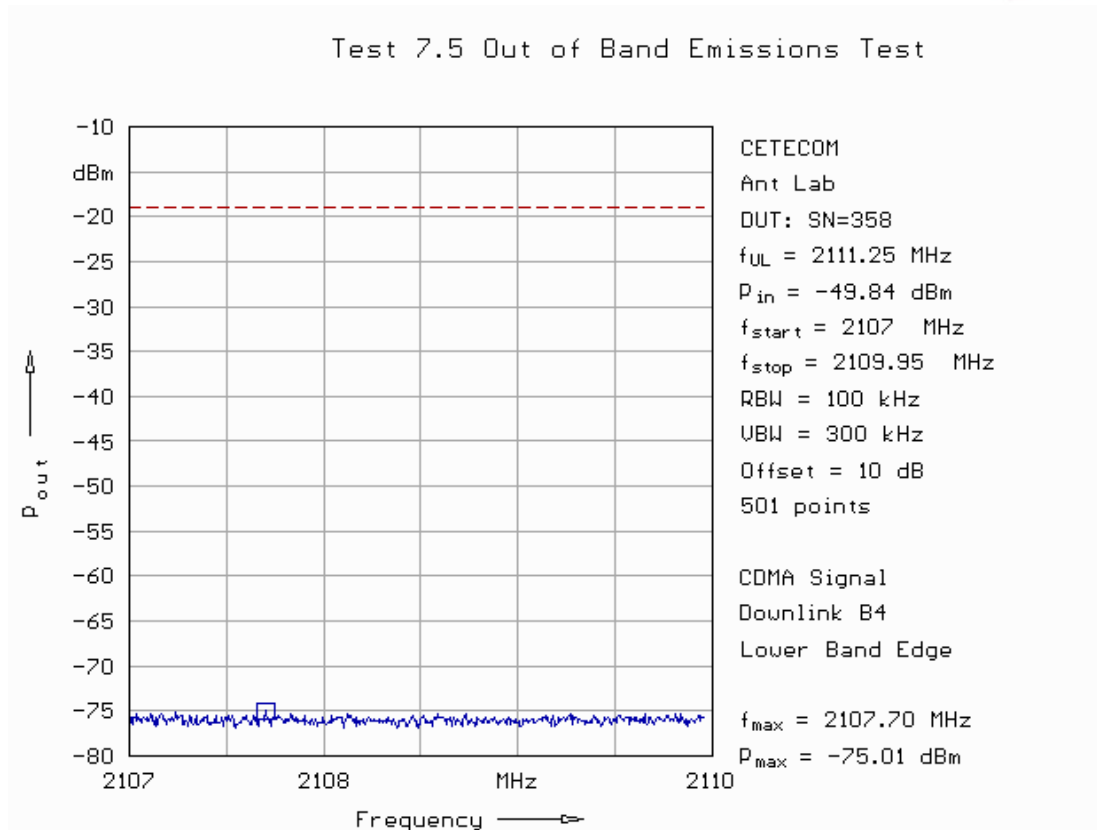

Fig. 112: Out-of-band emissions in downlink in band 4 applying a CDMA signal for the lower band edge.

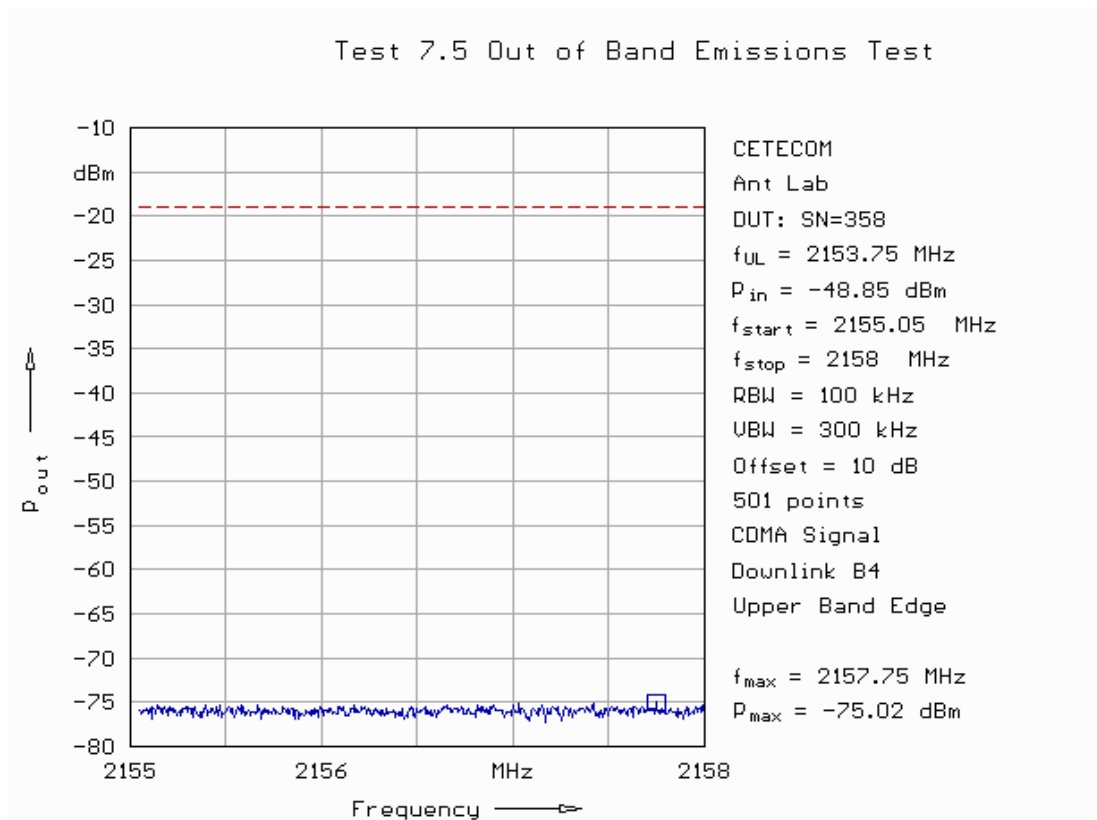

Fig. 113: Out-of-band emissions in downlink in band 4 applying a CDMA signal for the upper band edge.

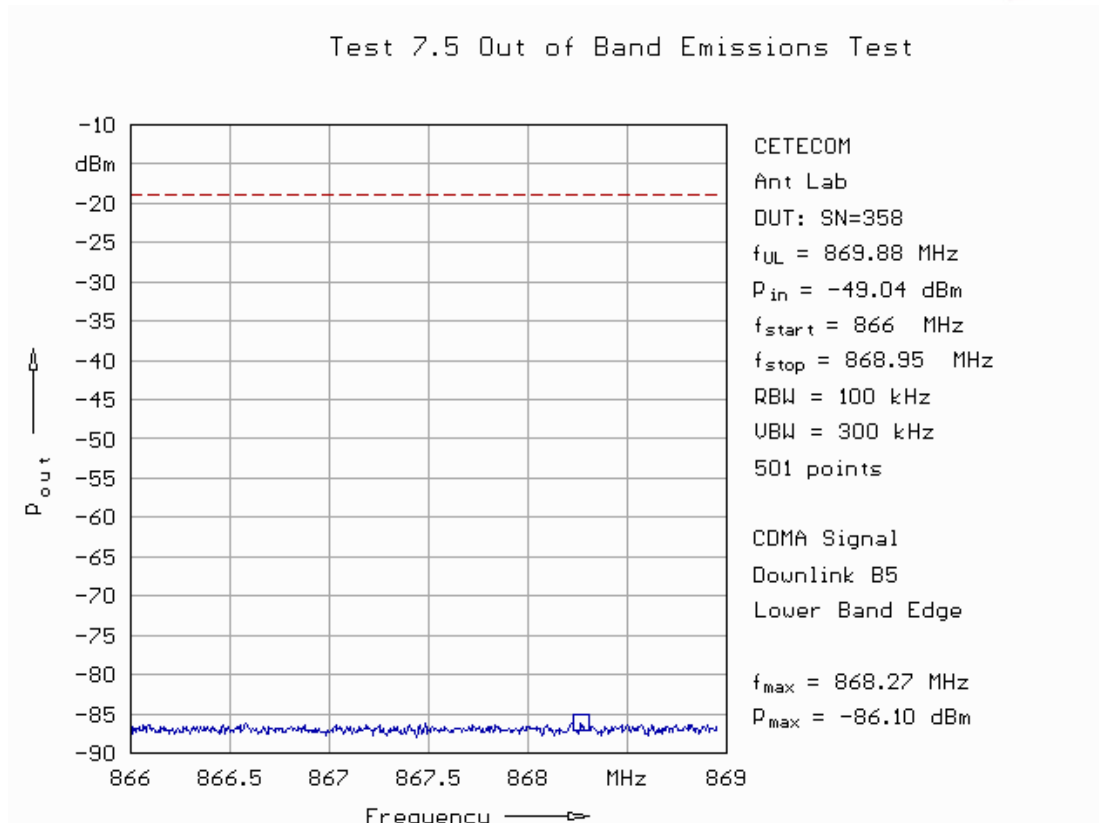

Fig. 114: Out-of-band emissions in downlink in band 5 applying a CDMA signal for the lower band edge.

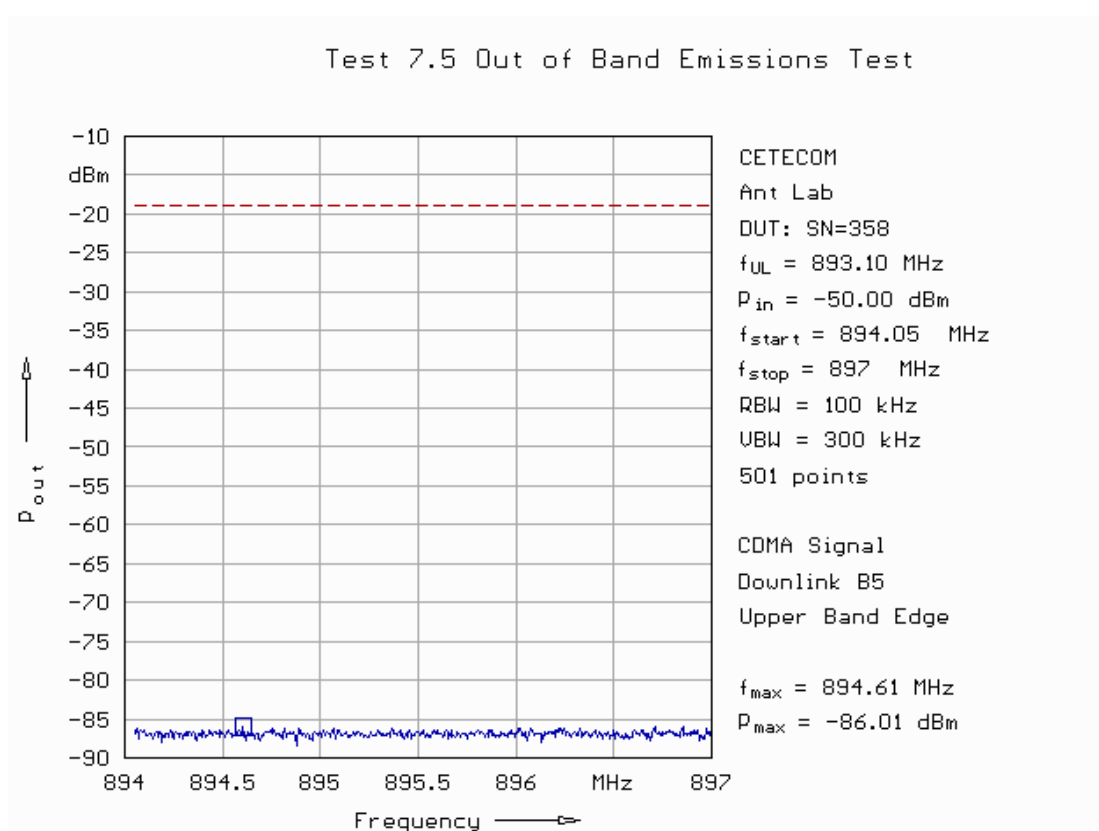

Fig. 115: Out-of-band emissions in downlink in band 5 applying a CDMA signal for the upper band edge.

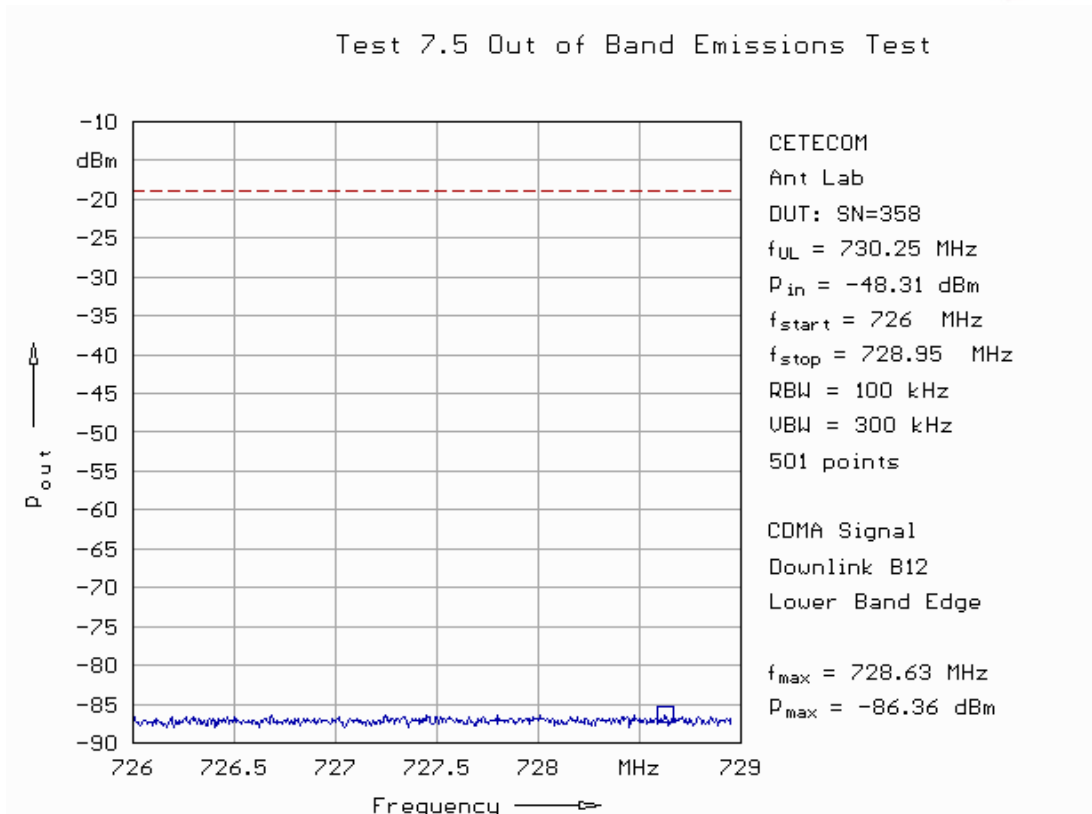

Fig. 116: Out-of-band emissions in downlink in band 12 applying a CDMA signal for the lower band edge.

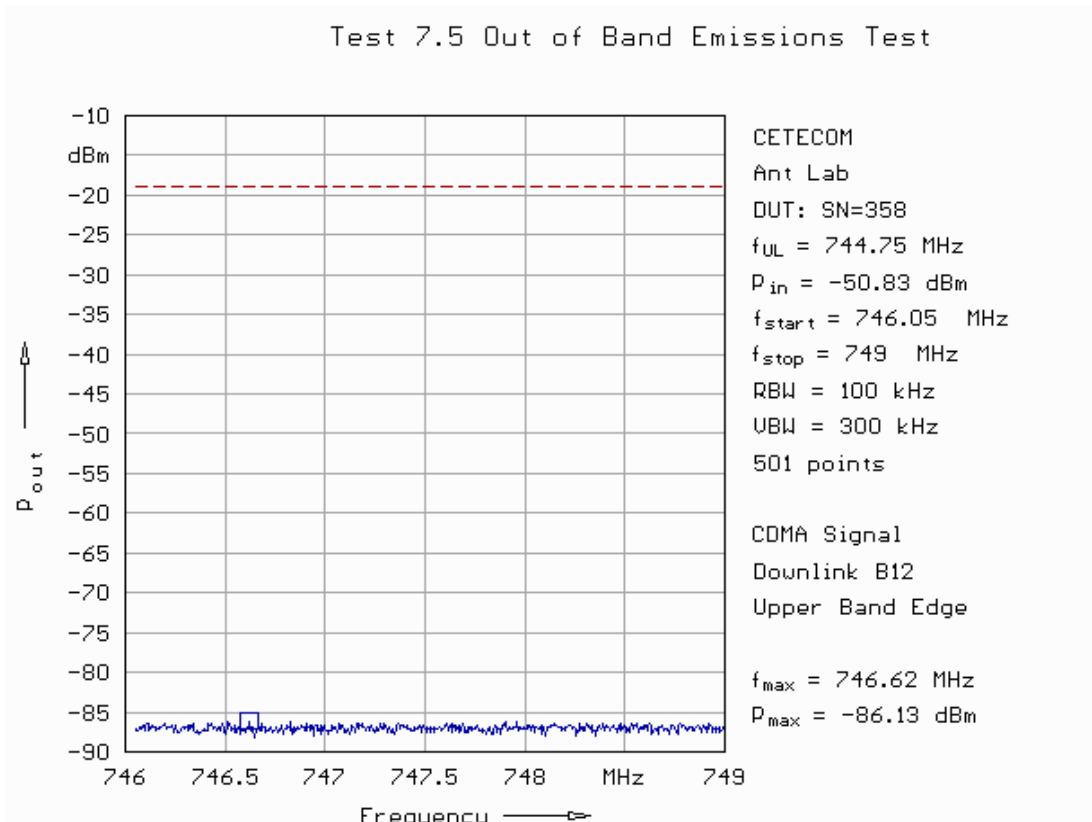

Fig. 117: Out-of-band emissions in downlink in band 12 applying a CDMA signal for the upper band edge.

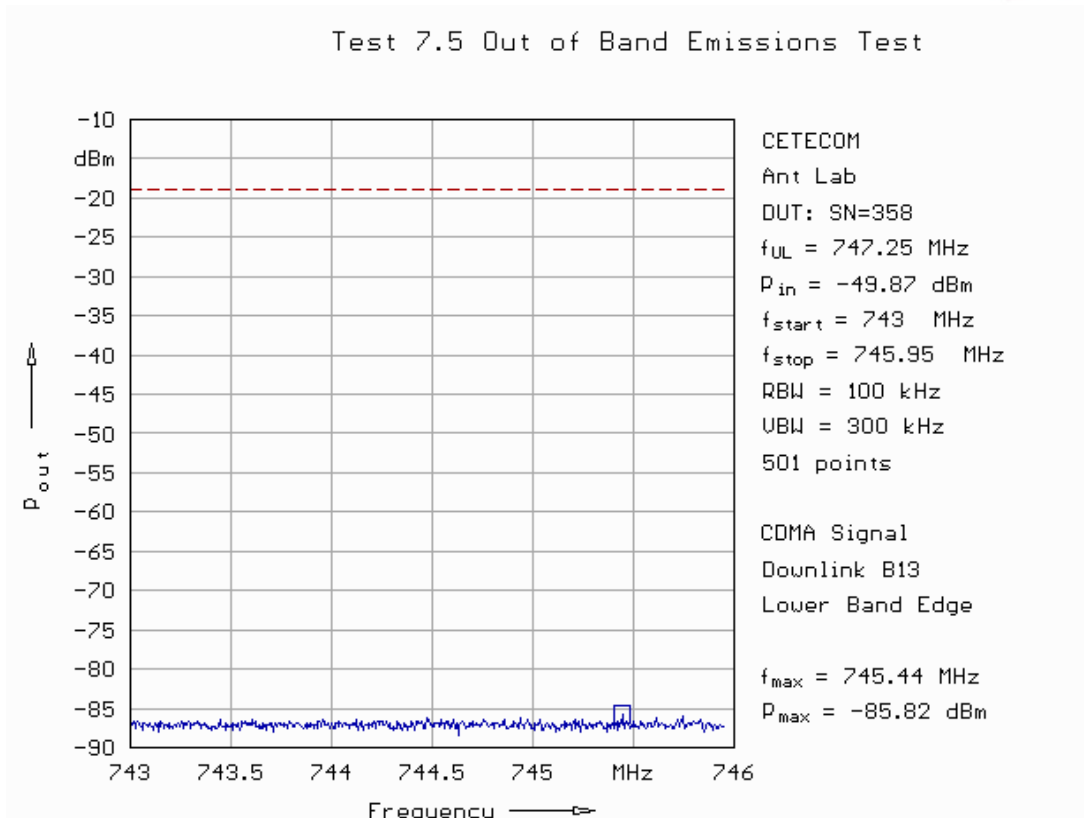

Fig. 118: Out-of-band emissions in downlink in band 13 applying a CDMA signal for the lower band edge.

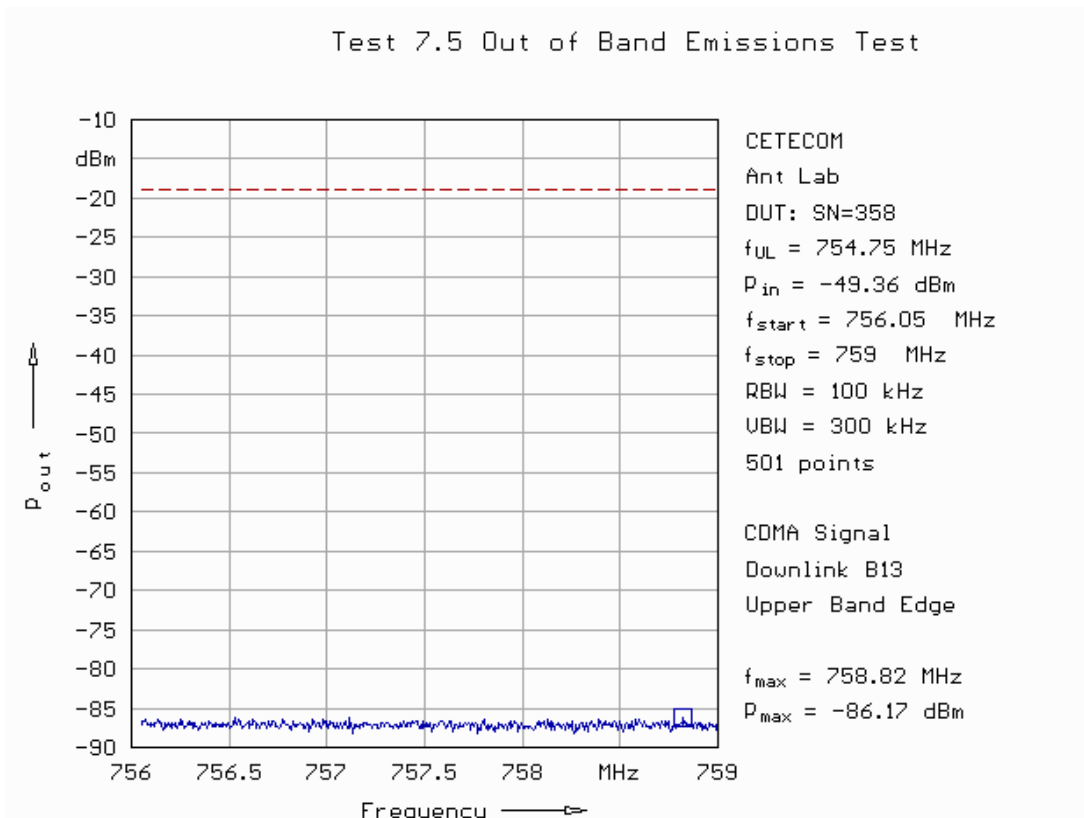

Fig. 119: Out-of-band emissions in downlink in band 13 applying a CDMA signal for the upper band edge.

5.6. Conducted Spurious Emissions

The activated cable routing for this test has been the same as used in chapter 5.1.

This test starts at 400 kHz since the minimal frequency created within the device is 410 kHz.

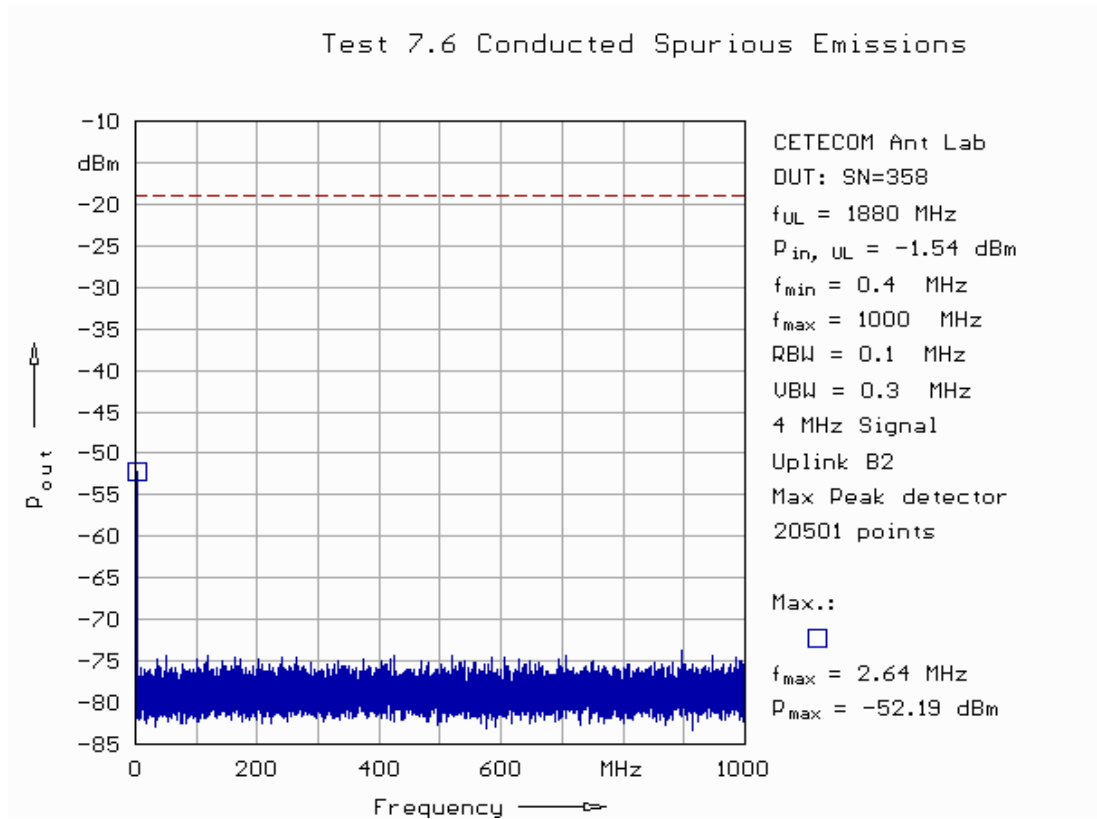

Fig. 120: Conducted spurious emissions in uplink in band 2 applying a 4 MHz signal (0.4 MHz – 1 GHz).

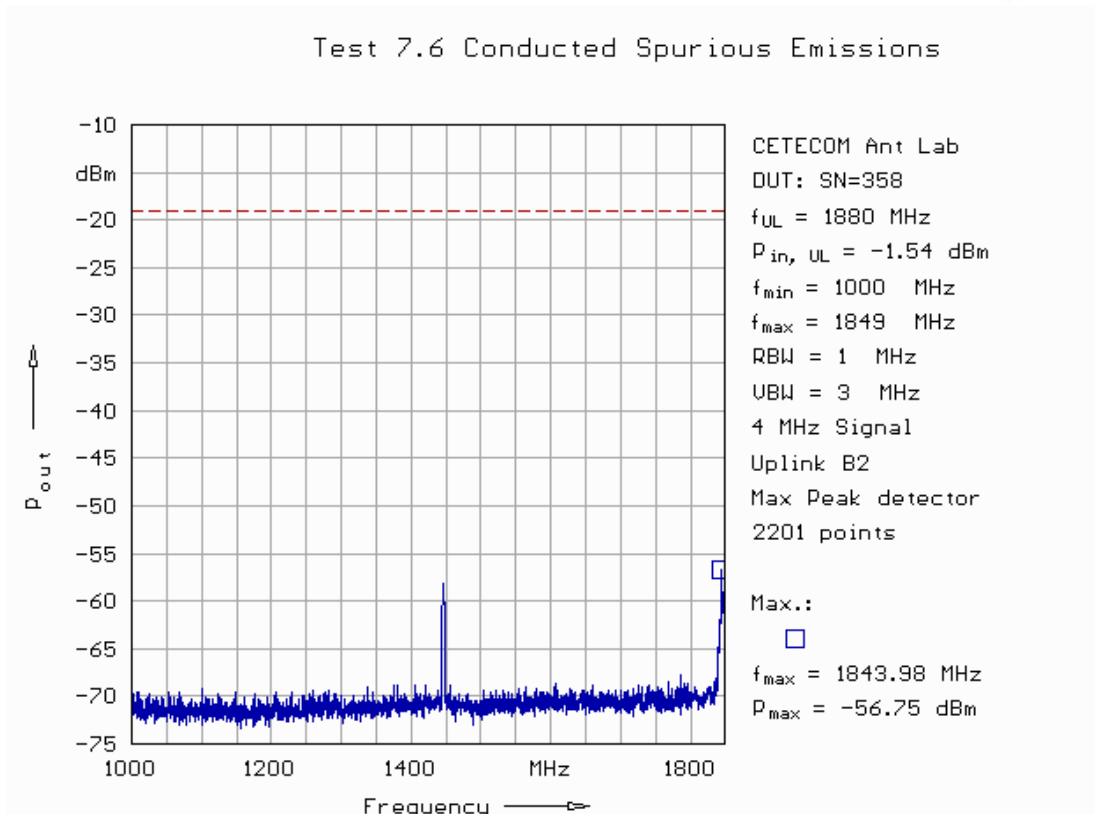

Fig. 121: Conducted spurious emissions in uplink in band 2 applying a 4 MHz signal (1 GHz – 1849 MHz).

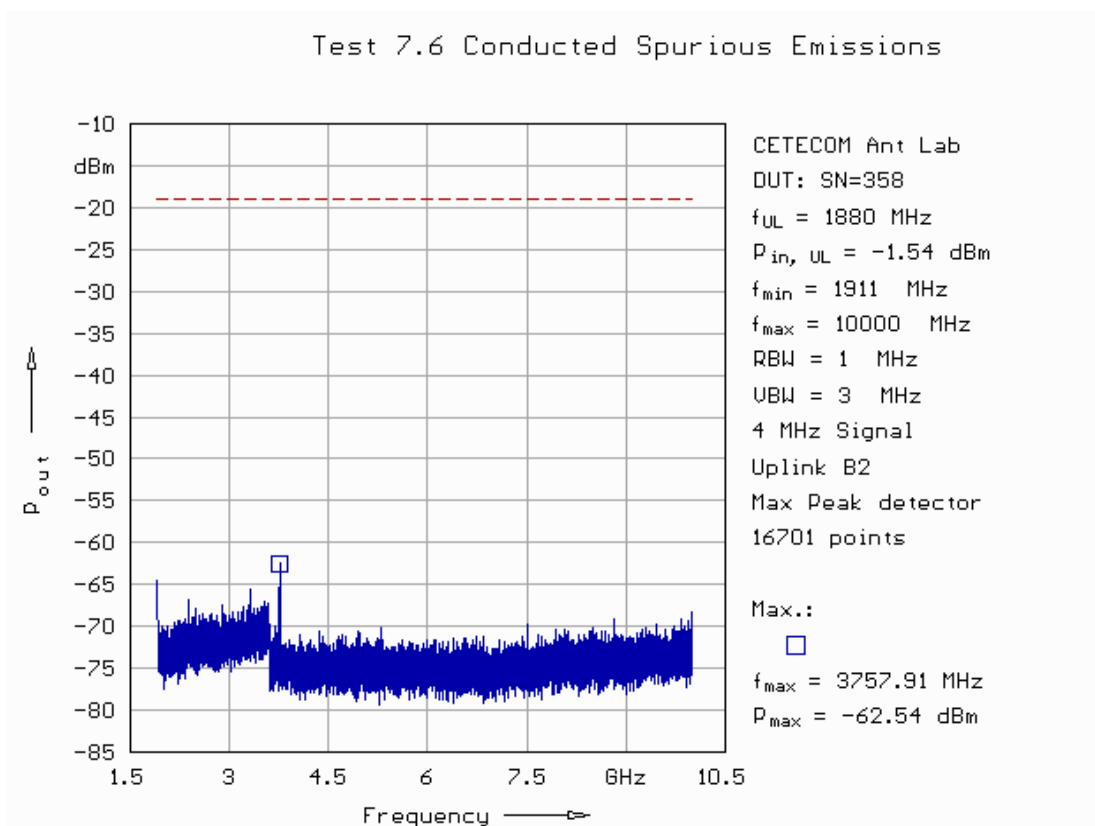

Fig. 122: Conducted spurious emissions in uplink in band 2 applying a 4 MHz signal (1911 MHz – 10 GHz).

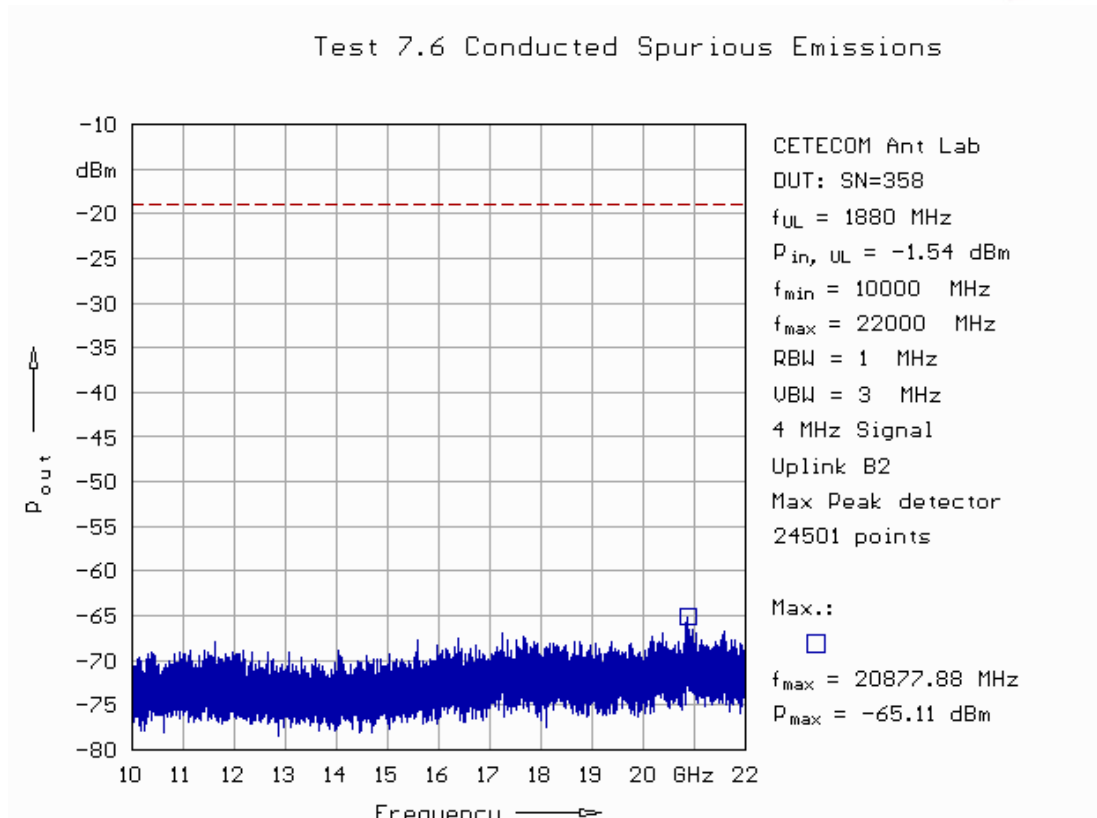

Fig. 123: Conducted spurious emissions in uplink in band 2 applying a 4 MHz signal (10 GHz – 22 GHz).

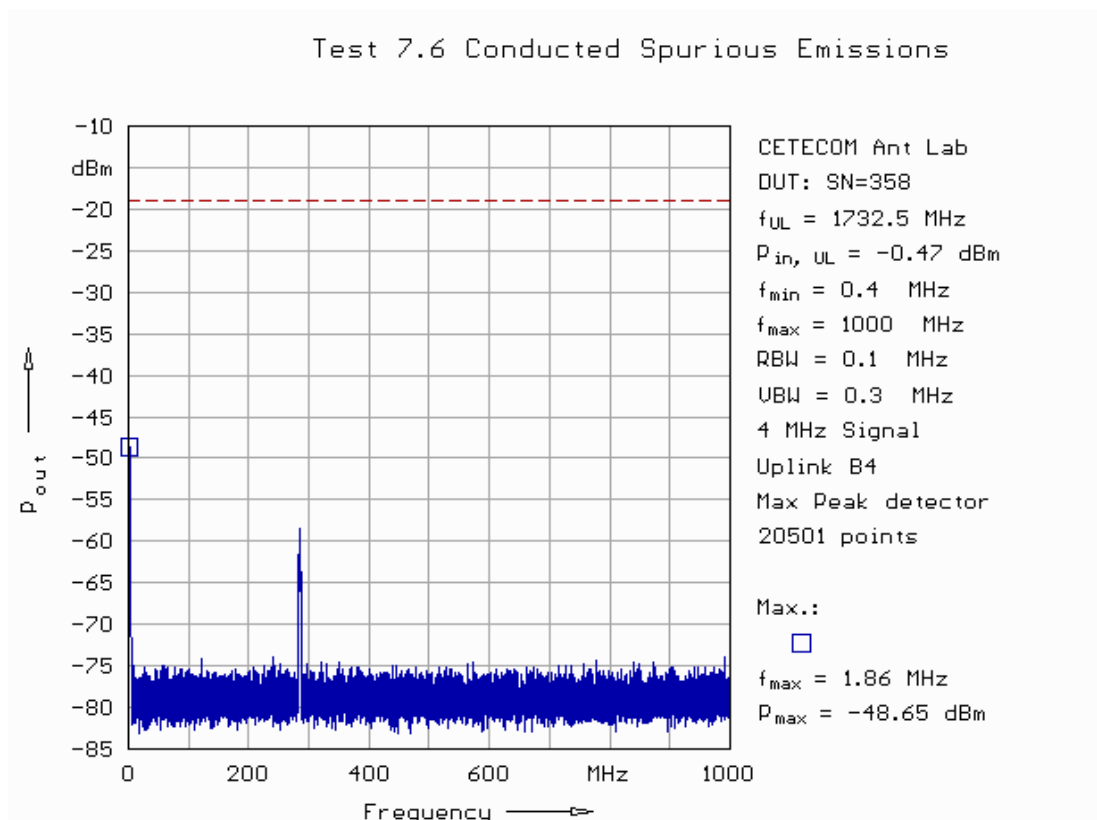

Fig. 124: Conducted spurious emissions in uplink in band 4 applying a 4 MHz signal (0.4 MHz – 1 GHz).

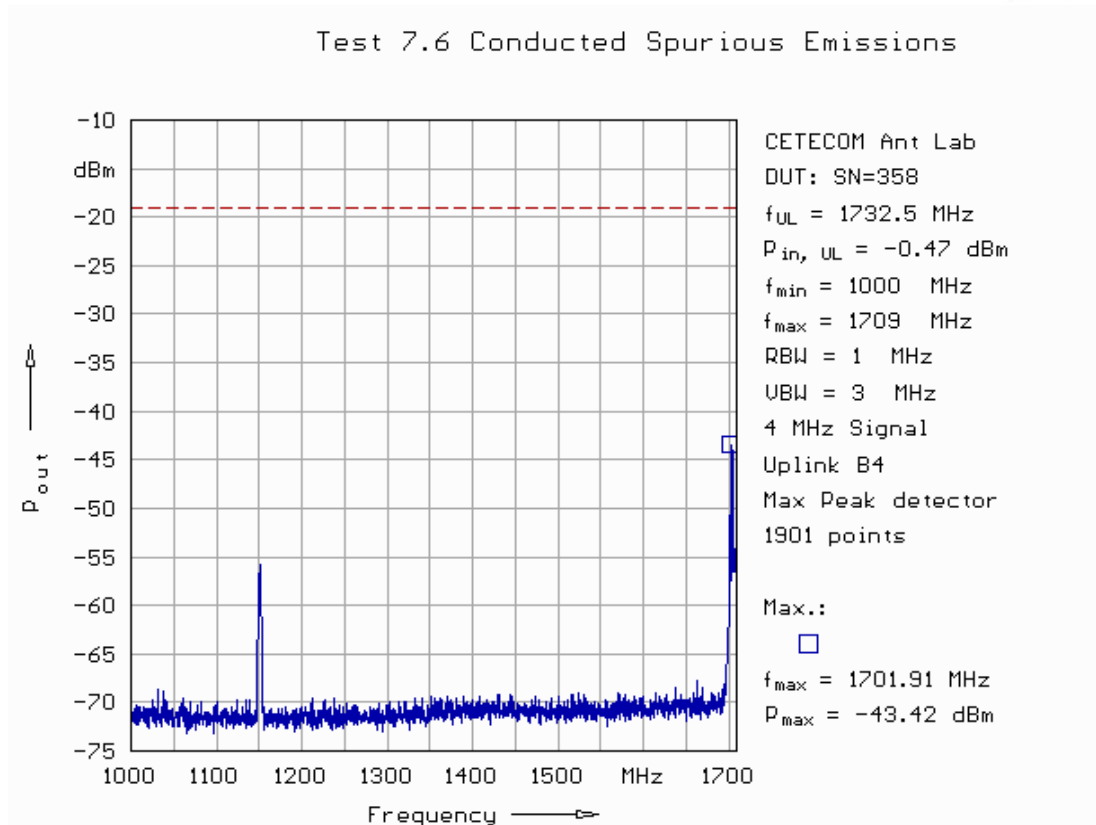

Fig. 125: Conducted spurious emissions in uplink in band 4 applying a 4 MHz signal (1 GHz – 1709 MHz).

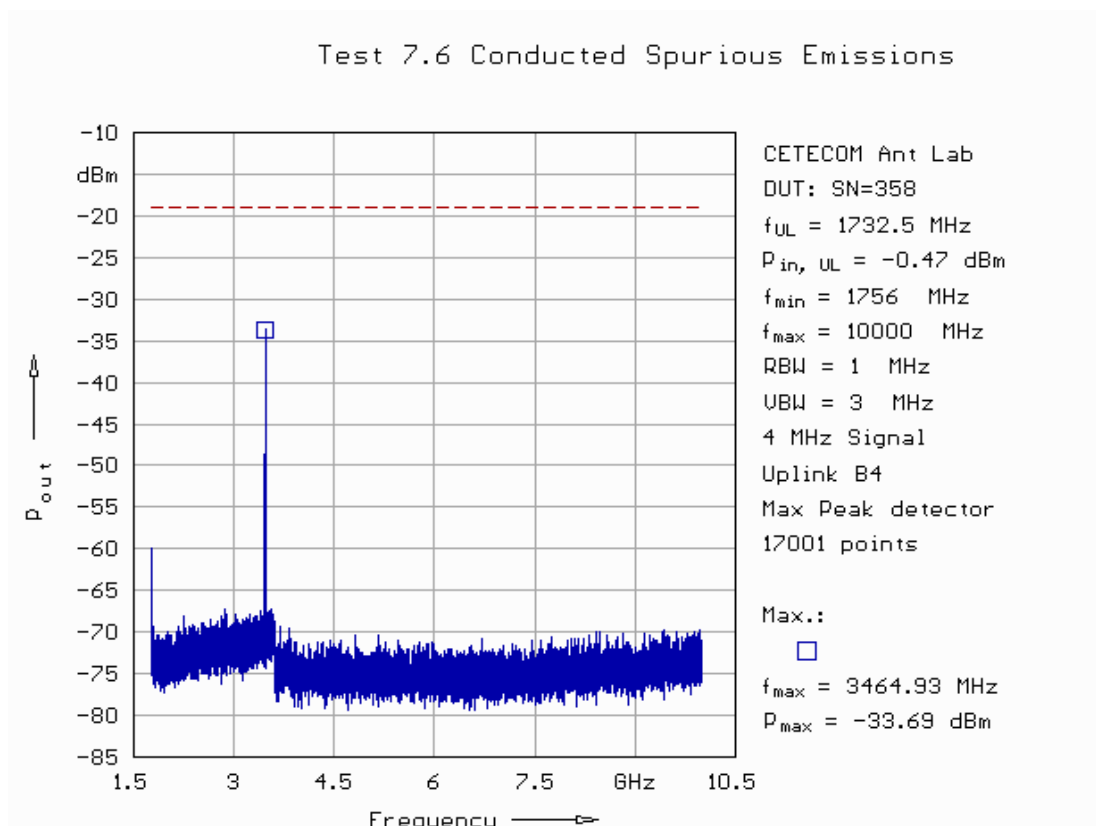

Fig. 126: Conducted spurious emissions in uplink in band 4 applying a 4 MHz signal (1756 MHz – 10 GHz).

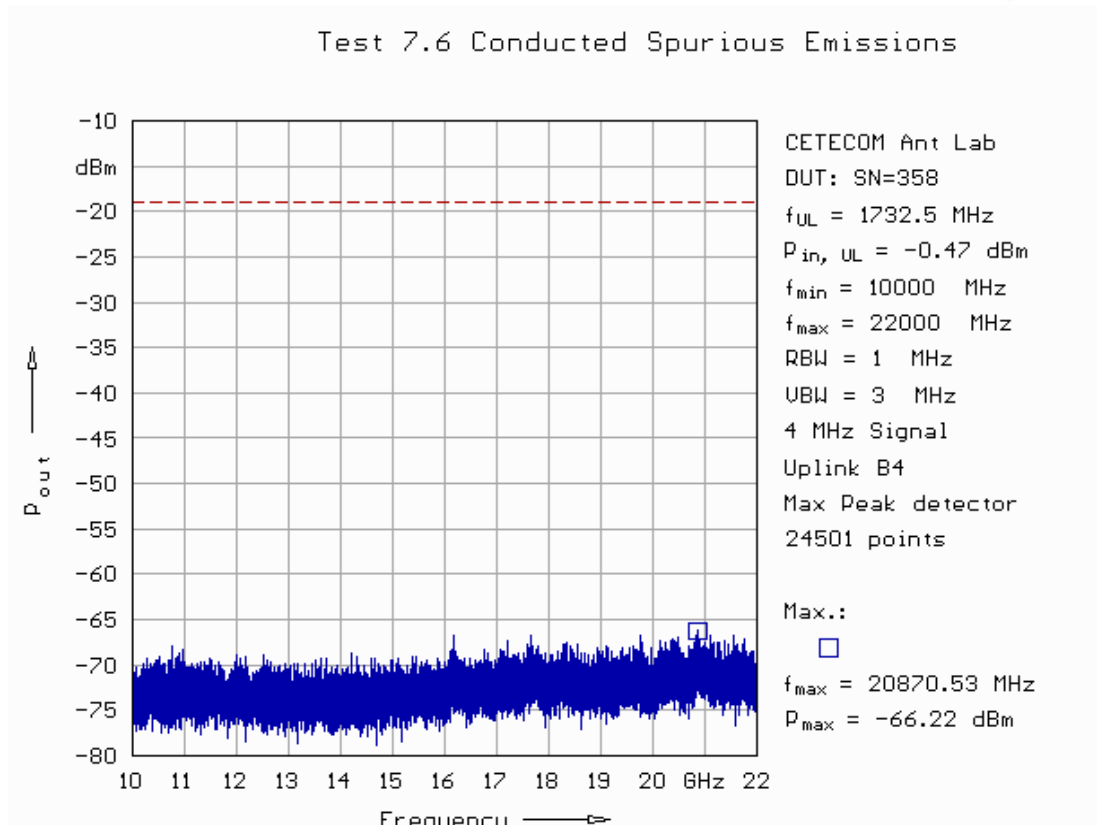

Fig. 127: Conducted spurious emissions in uplink in band 4 applying a 4 MHz signal (10 GHz – 22 GHz).

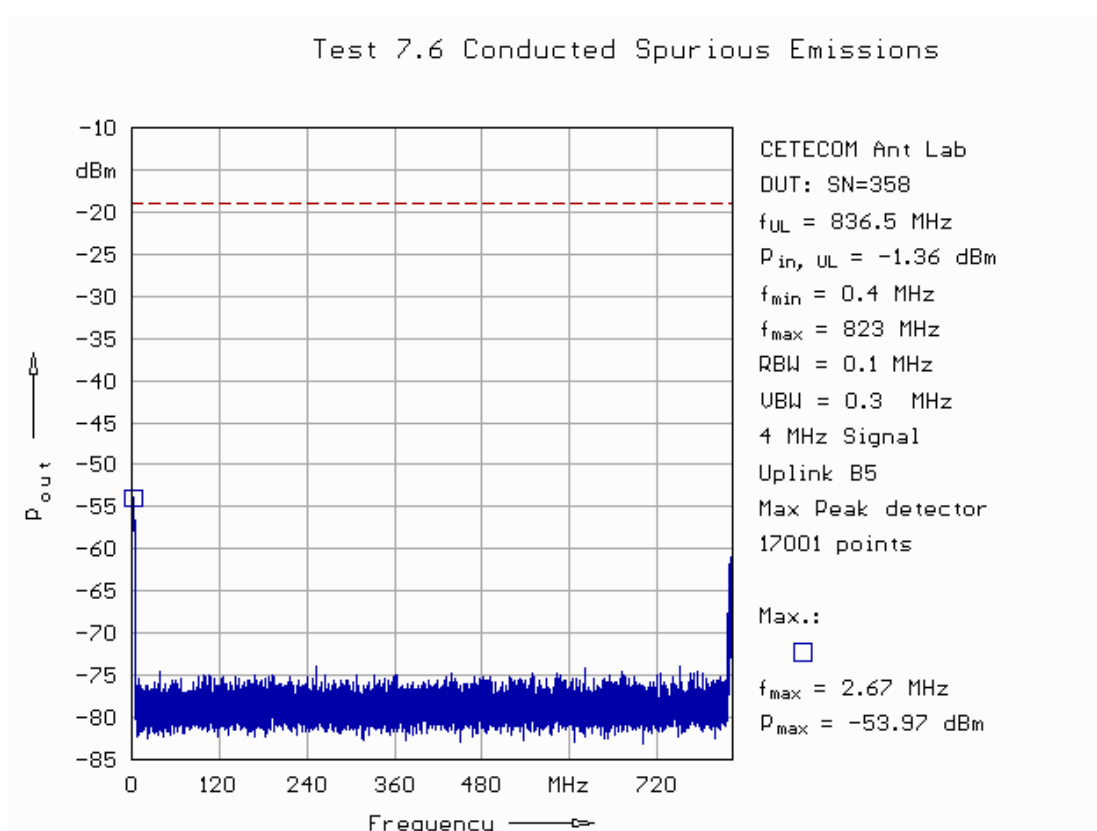

Fig. 128: Conducted spurious emissions in uplink in band 5 applying a 4 MHz signal (0.4 MHz – 823 MHz).

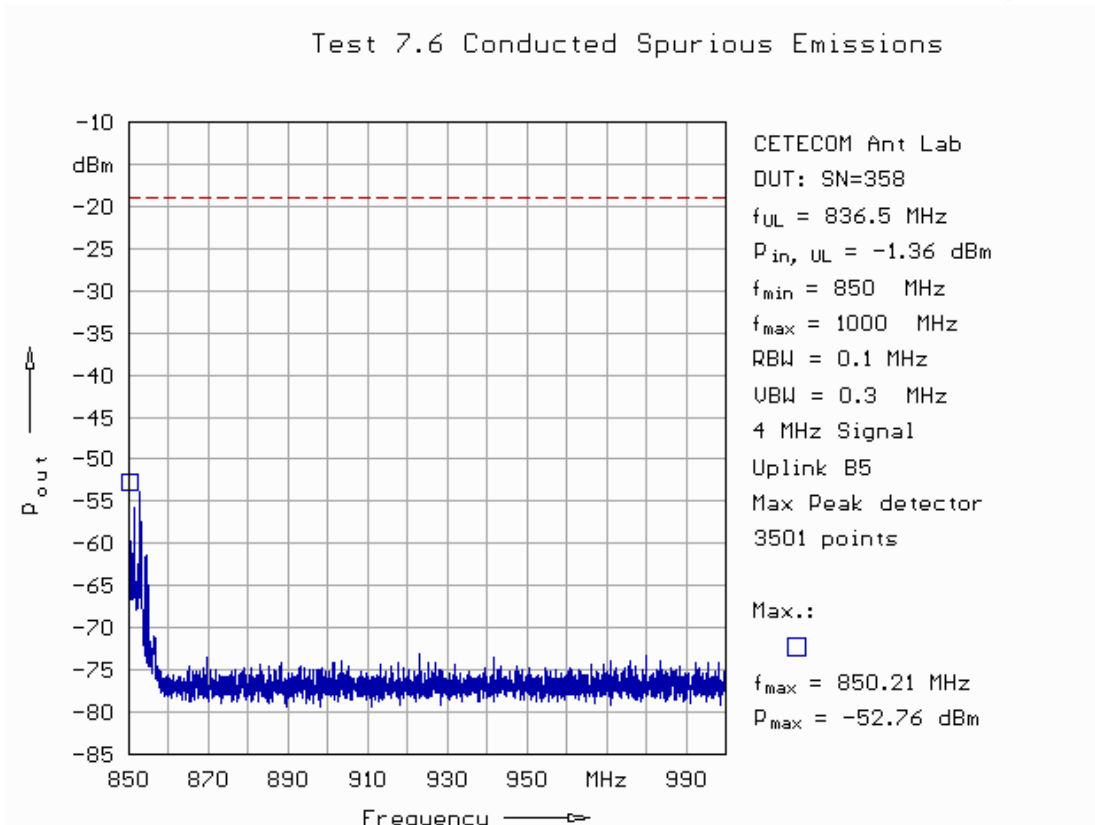

Fig. 129: Conducted spurious emissions in uplink in band 5 applying a 4 MHz signal (850 MHz – 1 GHz).

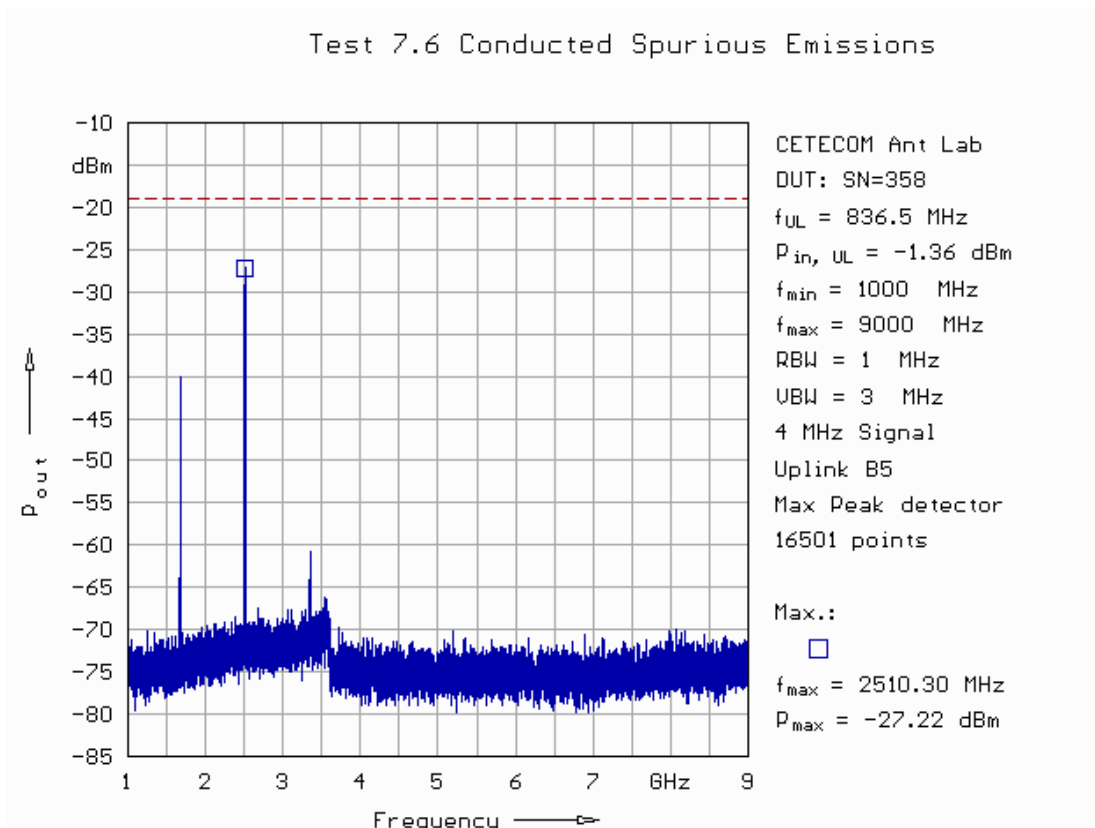

Fig. 130: Conducted spurious emissions in uplink in band 5 applying a 4 MHz signal (1 GHz – 9 GHz).

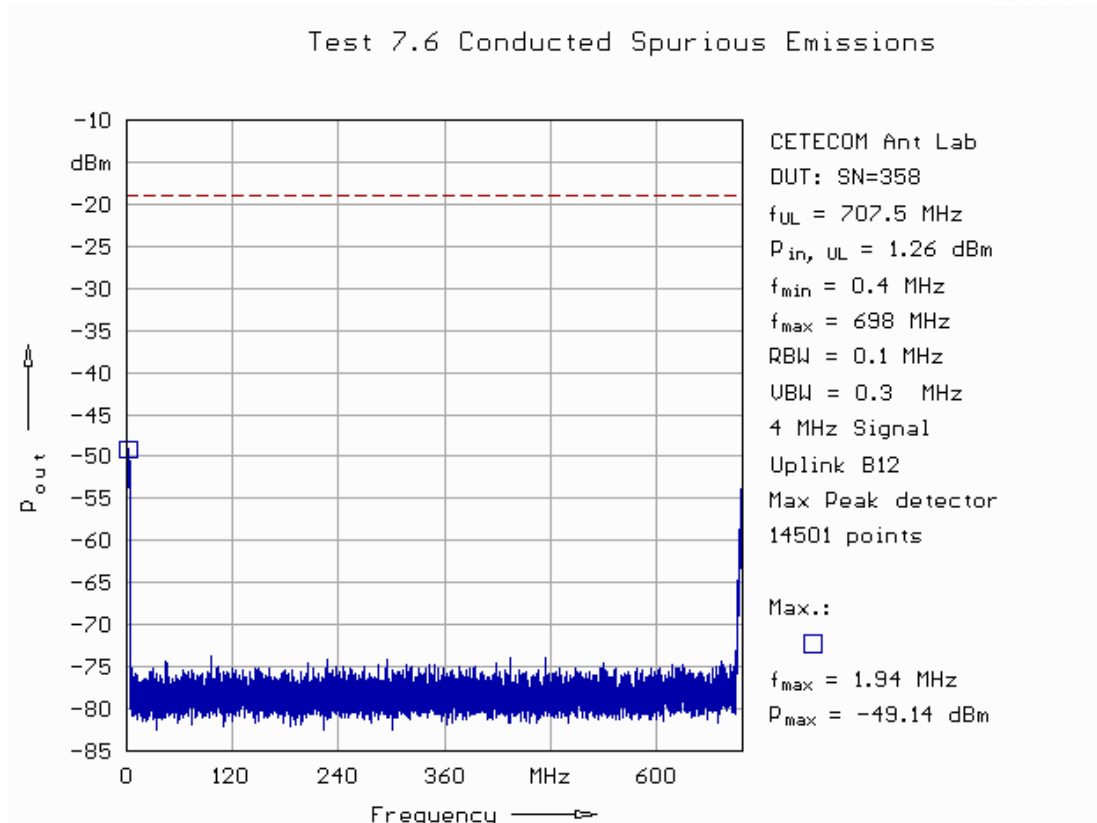

Fig. 131: Conducted spurious emissions in uplink in band 12 applying a 4 MHz signal (0.4 MHz – 698 MHz).

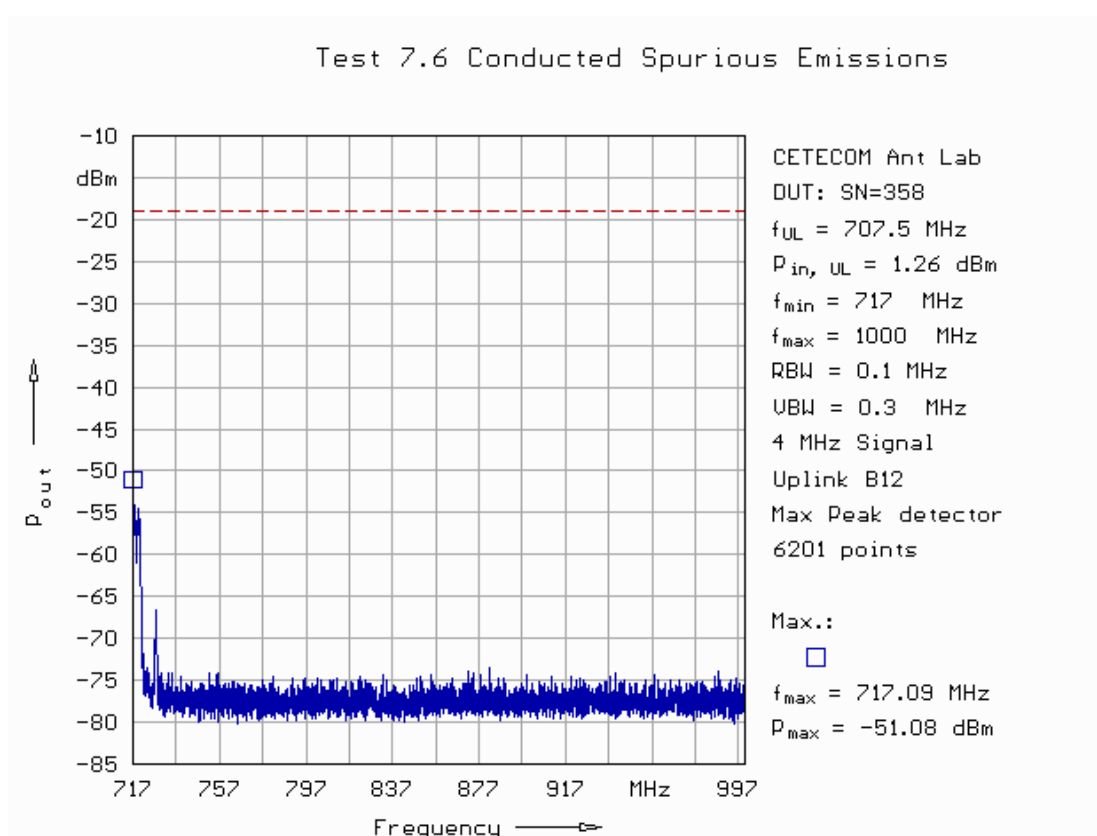

Fig. 132: Conducted spurious emissions in uplink in band 12 applying a 4 MHz signal (717 MHz – 1 GHz).

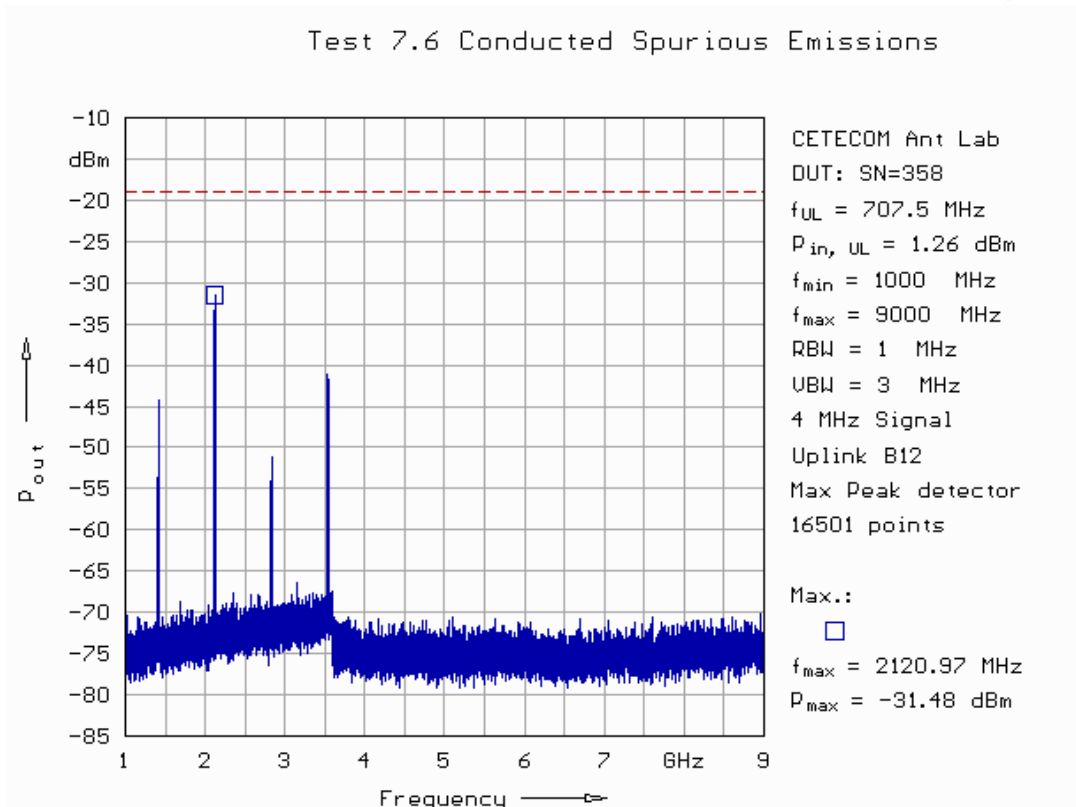

Fig. 133: Conducted spurious emissions in uplink in band 12 applying a 4 MHz signal (1 GHz – 9 GHz).

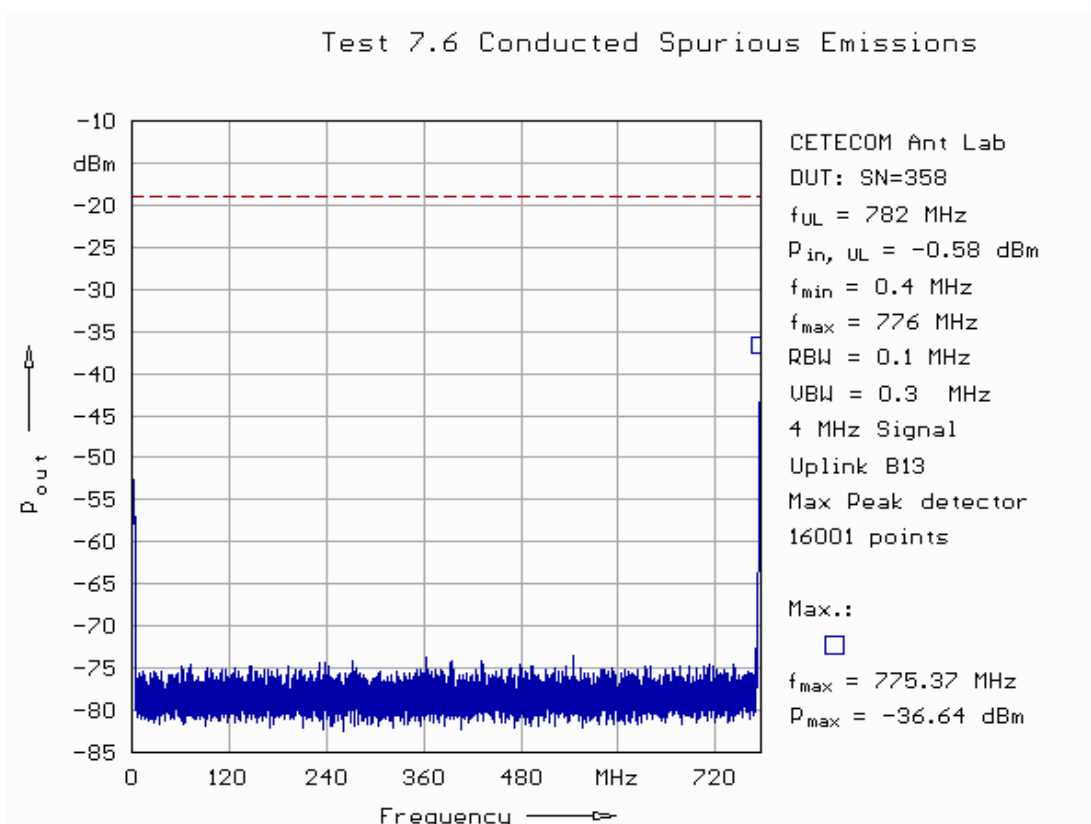

Fig. 134: Conducted spurious emissions in uplink in band 13 applying a 4 MHz signal (0.4 MHz – 776 MHz).

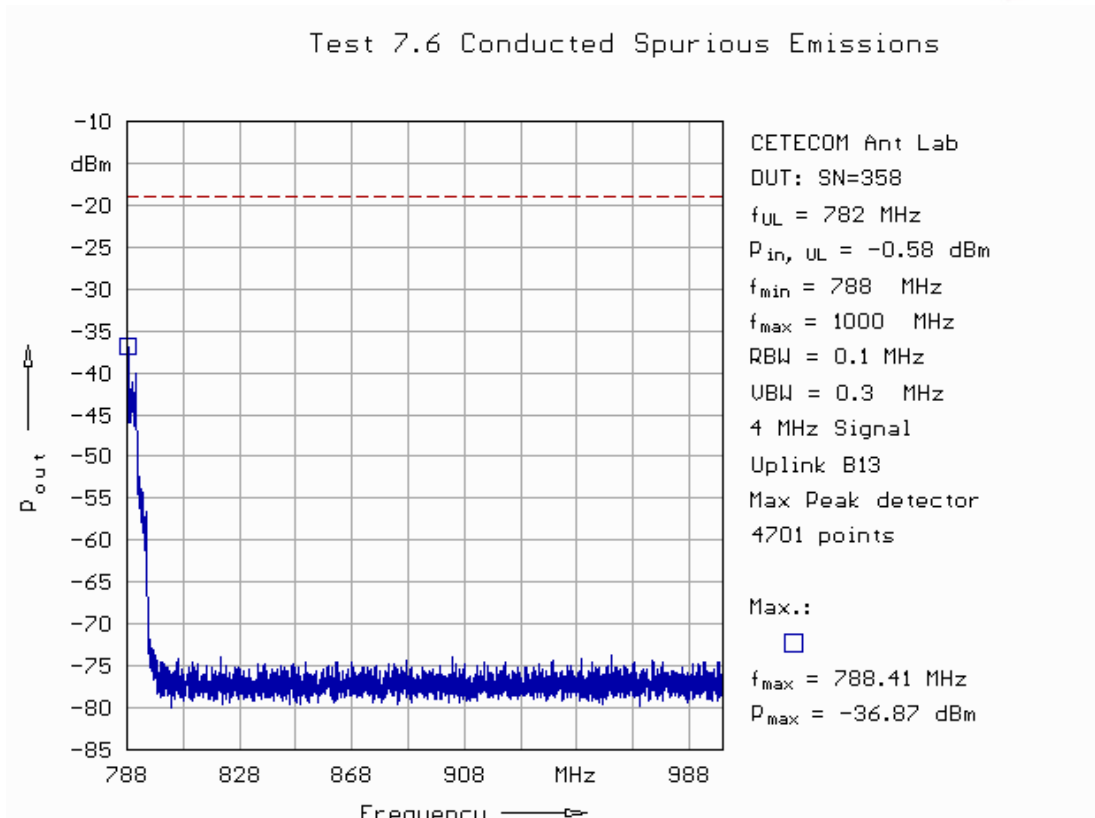

Fig. 135: Conducted spurious emissions in uplink in band 13 applying a 4 MHz signal (788 MHz – 1 GHz).

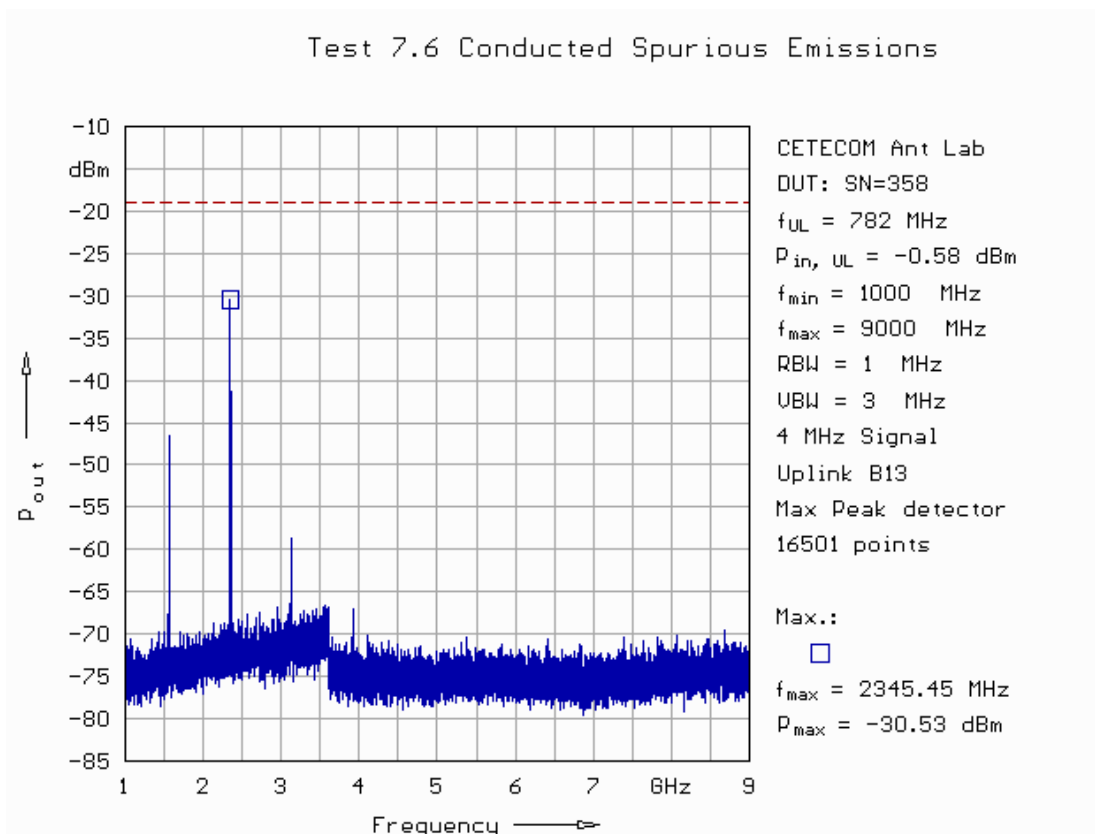

Fig. 136: Conducted spurious emissions in uplink in band 13 applying a 4 MHz signal (1 GHz – 9 GHz).

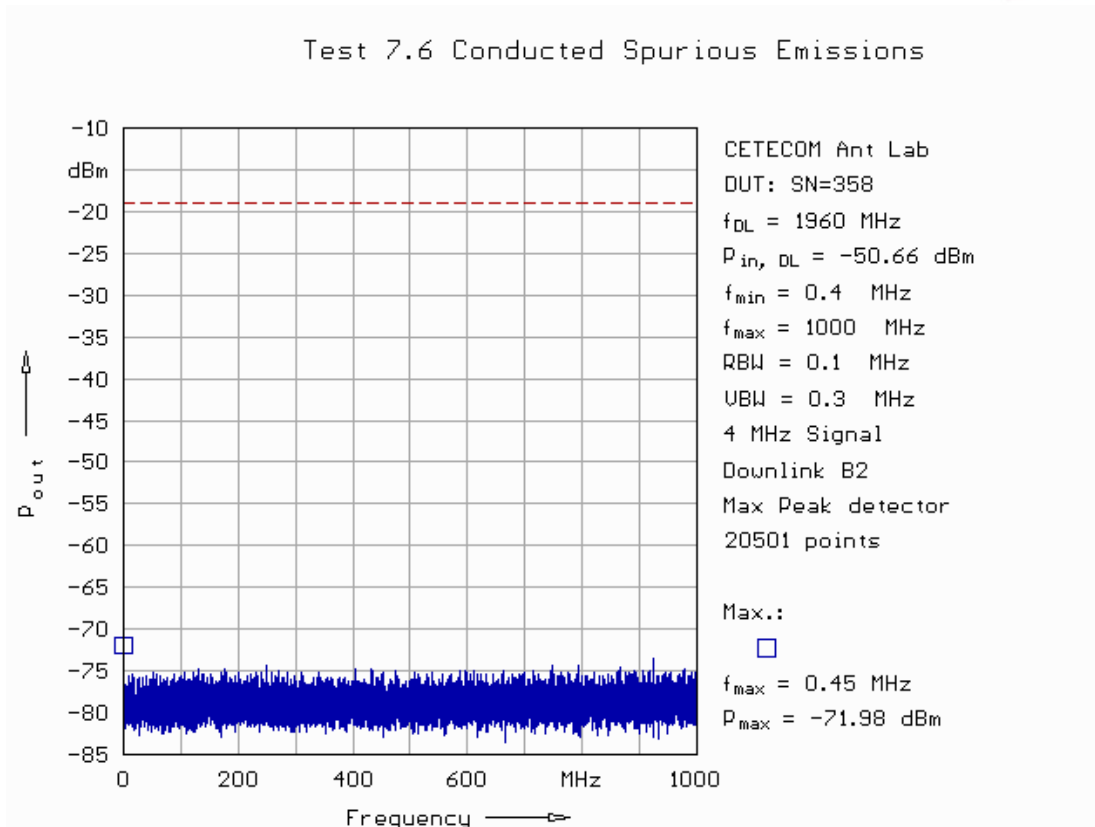

Fig. 137: Conducted spurious emissions in downlink in band 2 applying a 4 MHz signal (0.4 MHz – 1 GHz).

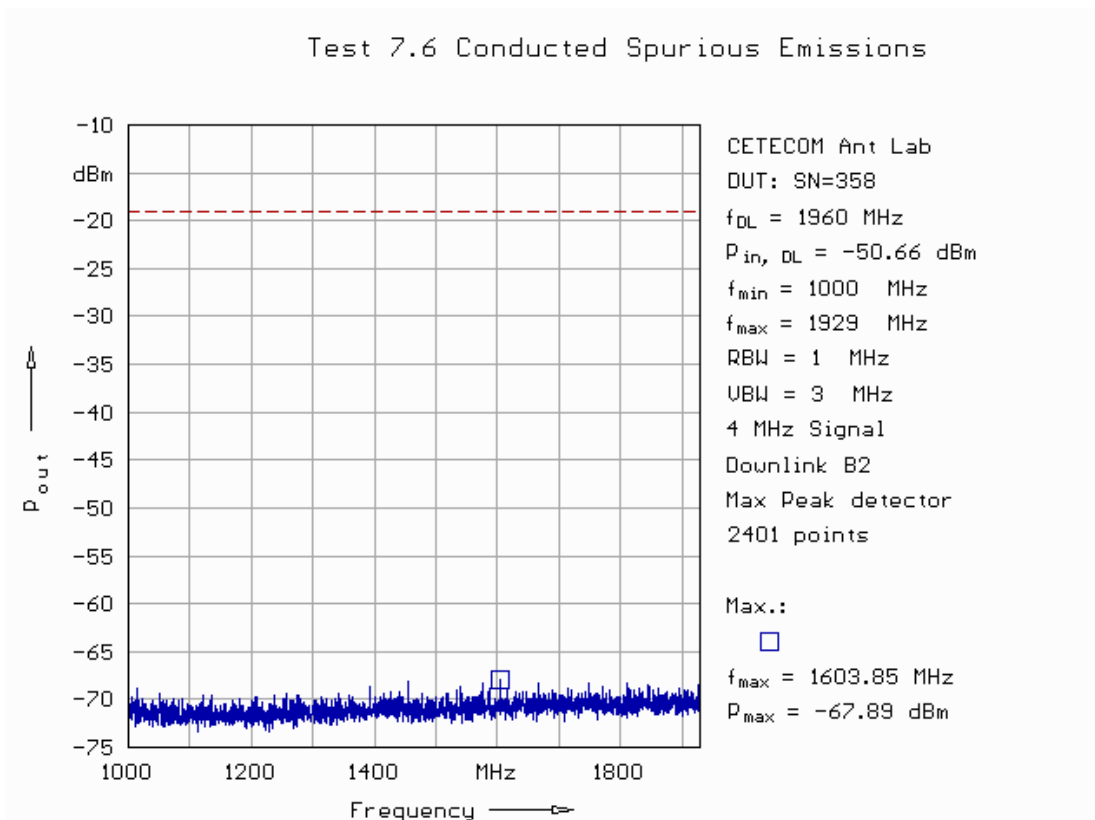

Fig. 138: Conducted spurious emissions in downlink in band 2 applying a 4 MHz signal (1 GHz – 1929 MHz).

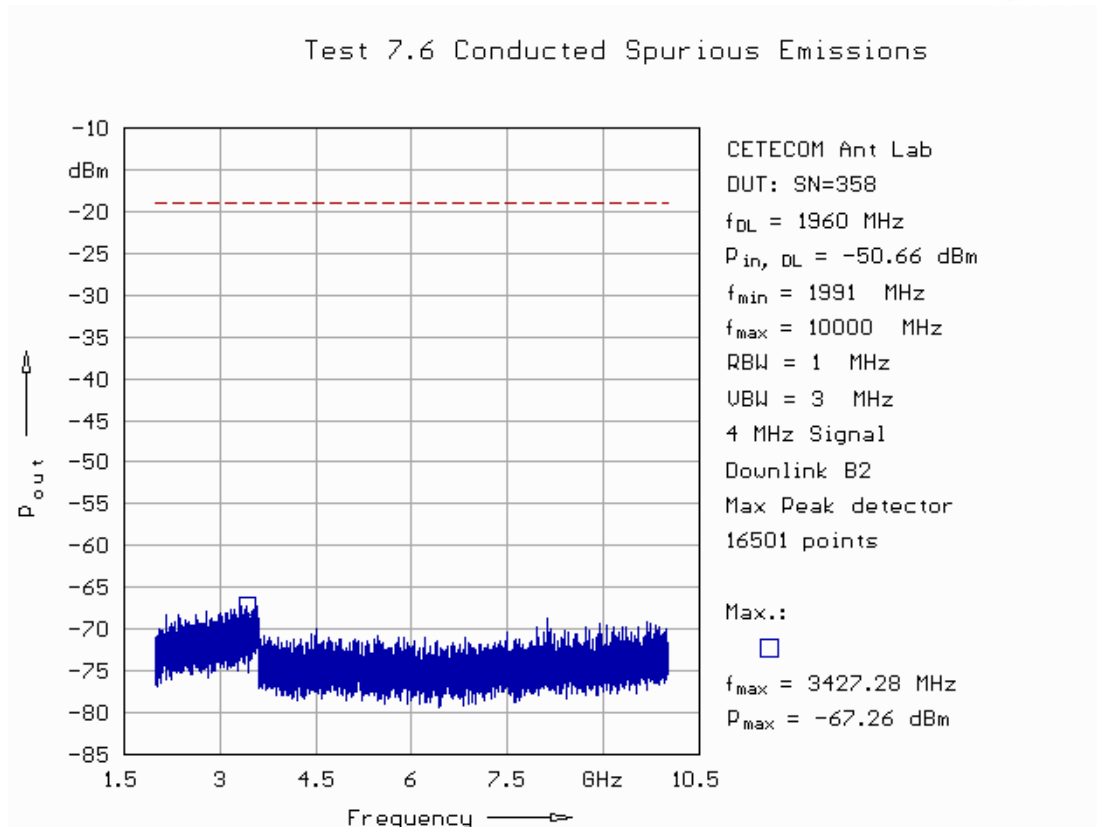

Fig. 139: Conducted spurious emissions in downlink in band 2 applying a 4 MHz signal (1911 MHz – 10 GHz).

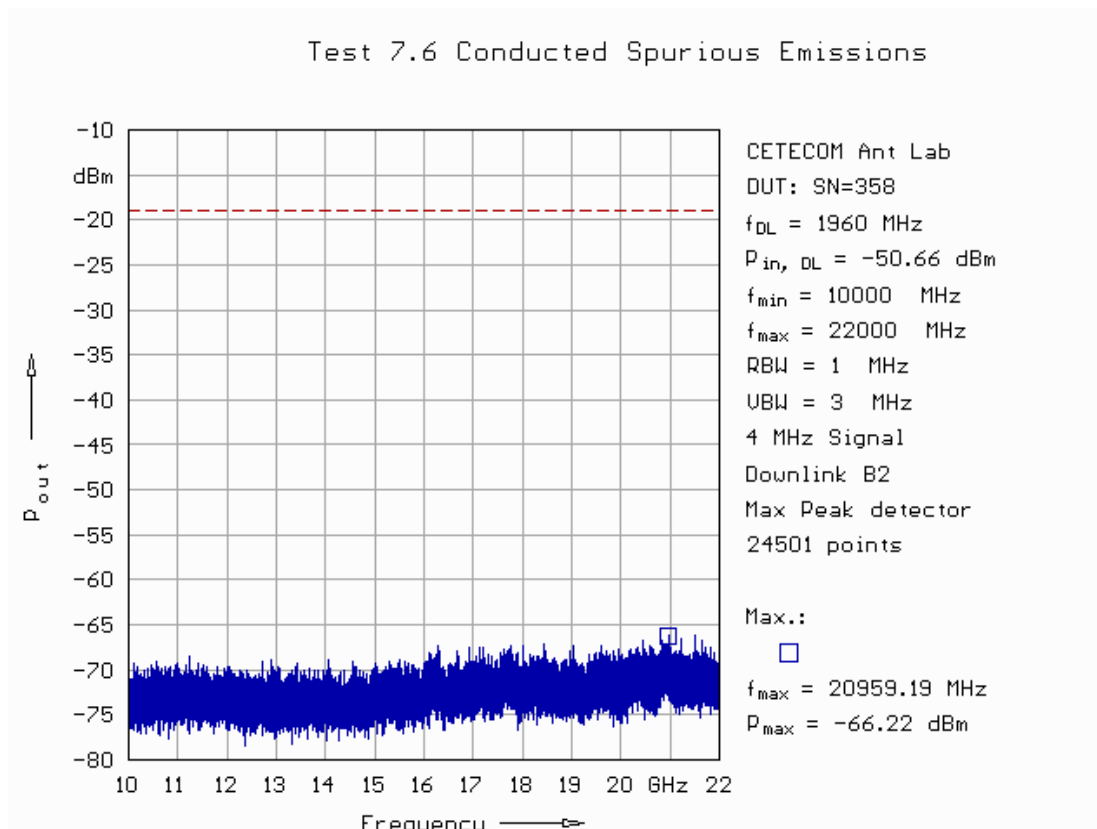

Fig. 140: Conducted spurious emissions in downlink in band 2 applying a 4 MHz signal (10 GHz – 22 GHz).

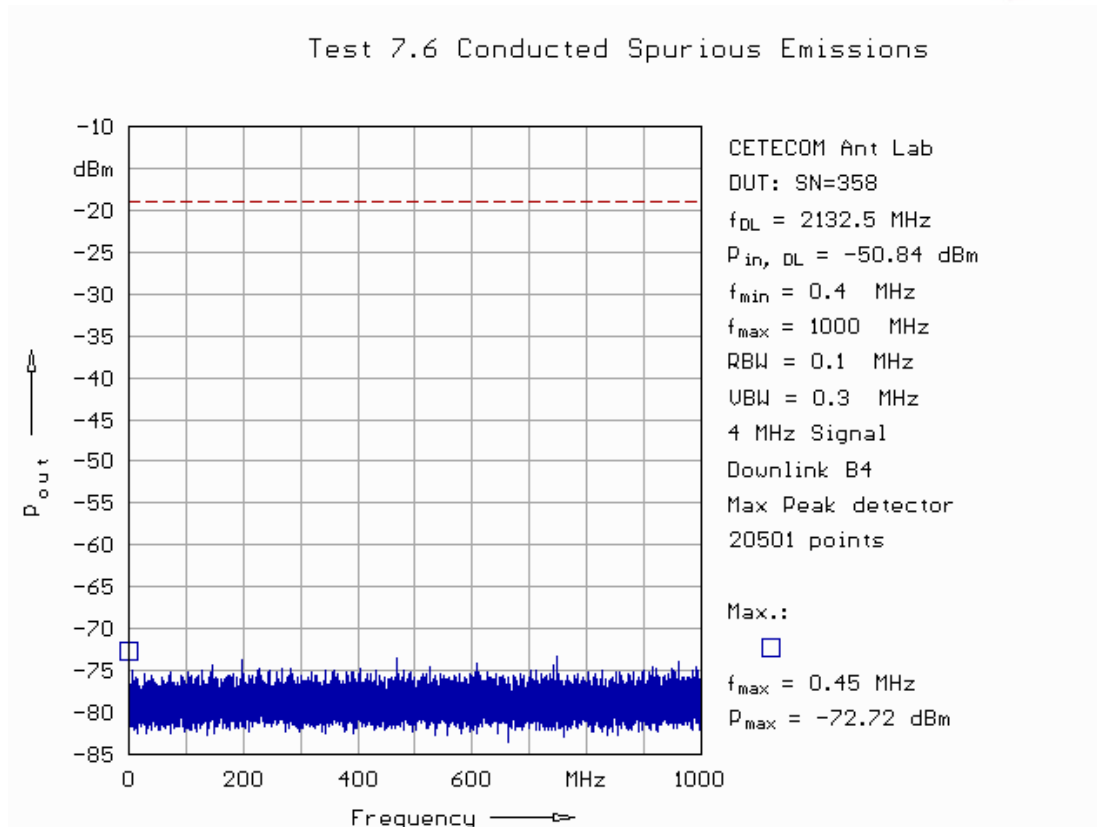

Fig. 141: Conducted spurious emissions in downlink in band 4 applying a 4 MHz signal (0.4 MHz – 1 GHz).

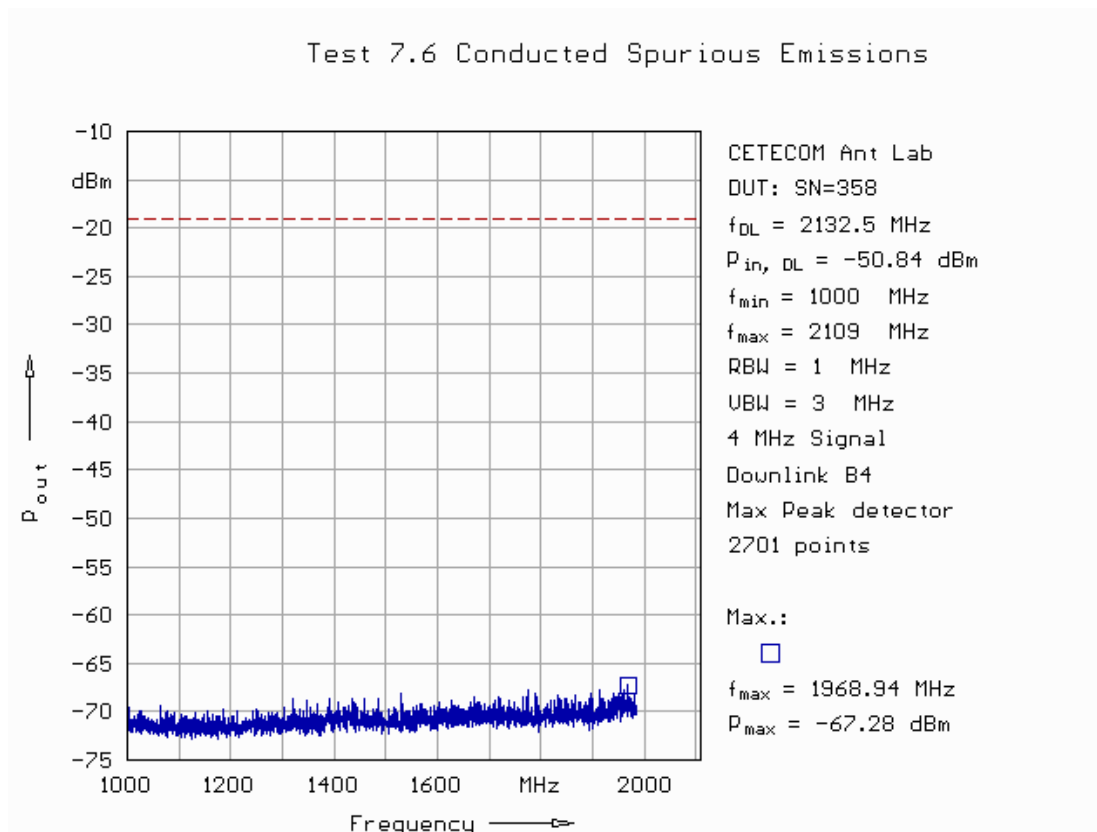

Fig. 142: Conducted spurious emissions in downlink in band 4 applying a 4 MHz signal (1 GHz – 2109 MHz).

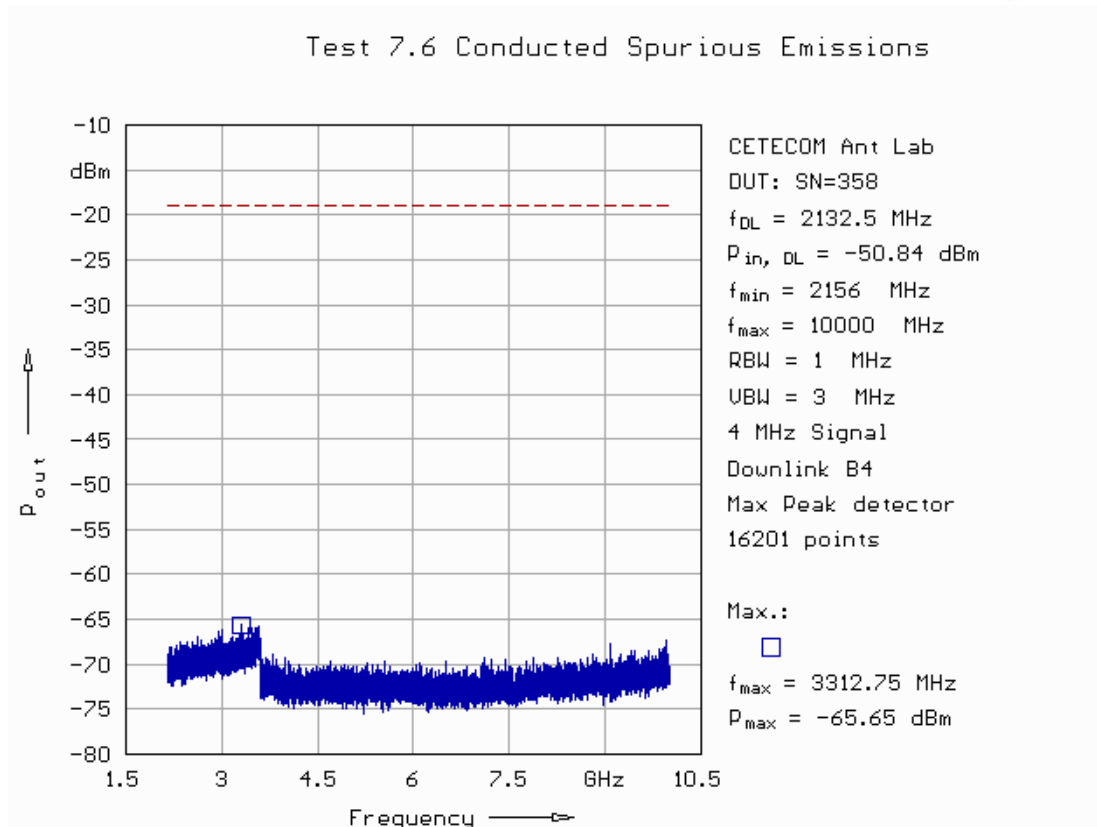

Fig. 143: Conducted spurious emissions in downlink in band 4 applying a 4 MHz signal (2156 MHz – 10 GHz).

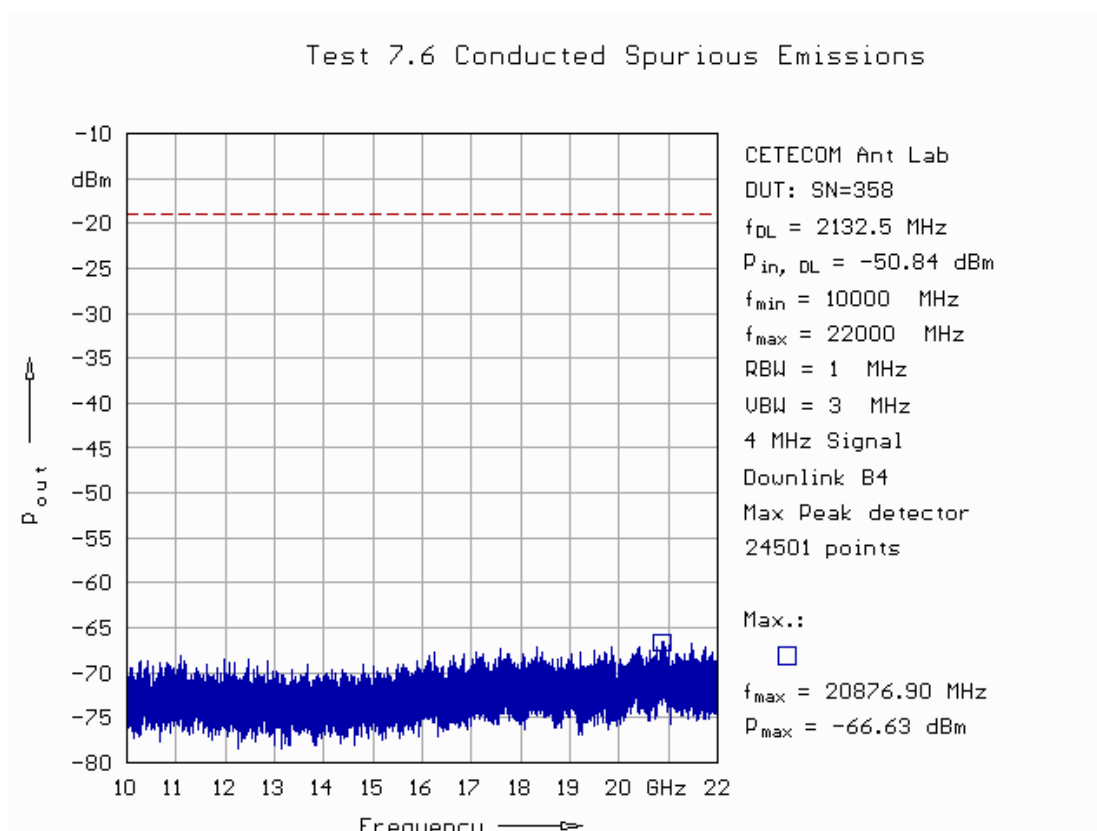

Fig. 144: Conducted spurious emissions in downlink in band 4 applying a 4 MHz signal (10 GHz – 22 GHz).

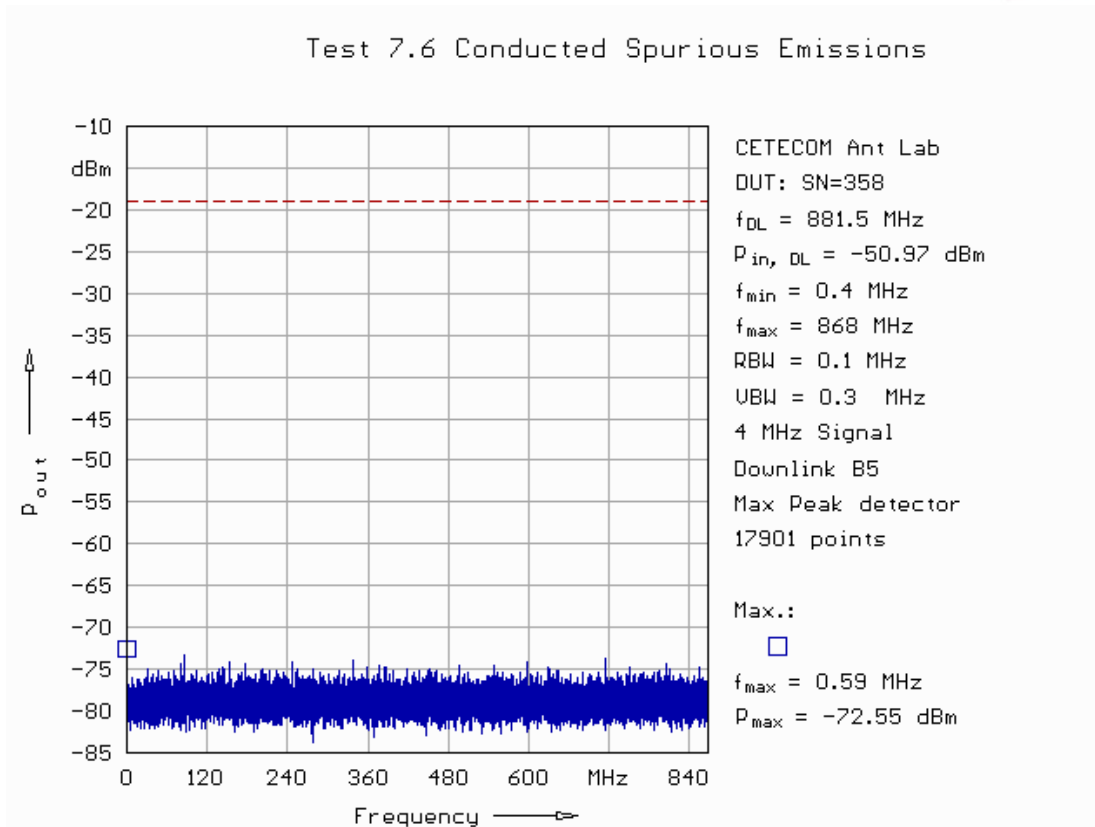

Fig. 145: Conducted spurious emissions in downlink in band 5 applying a 4 MHz signal (0.4 MHz – 868 MHz).

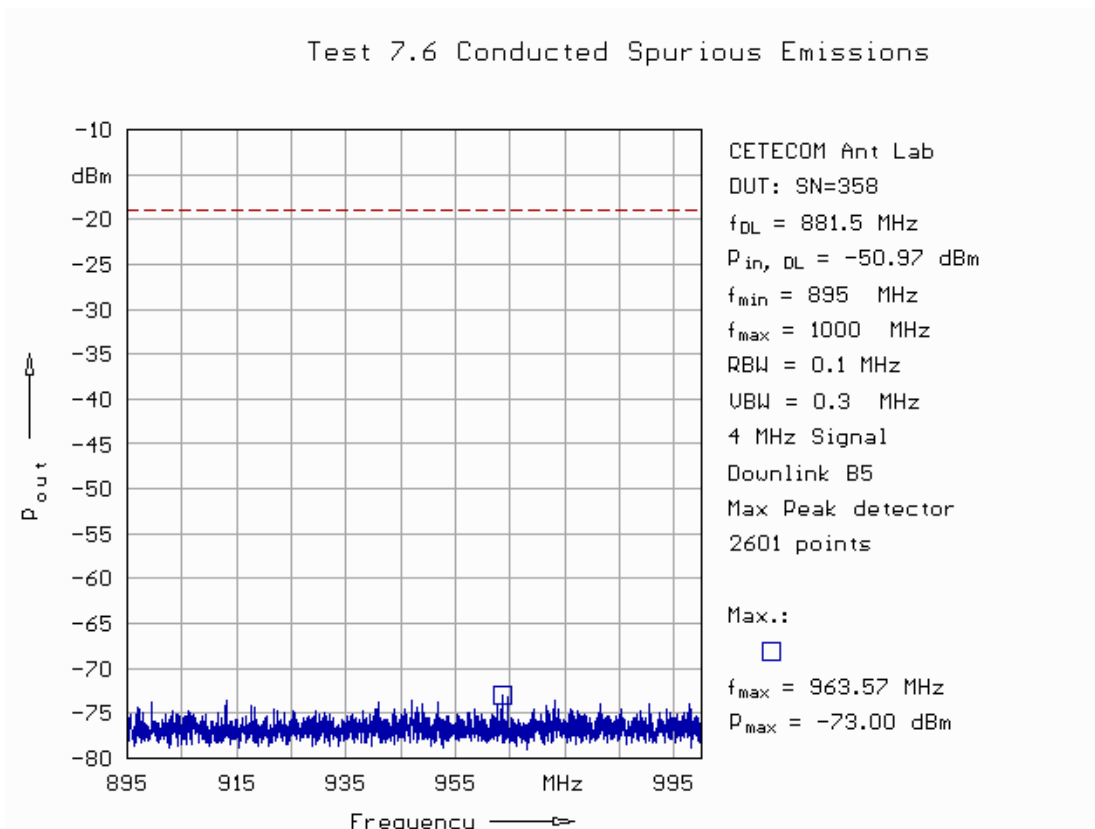

Fig. 146: Conducted spurious emissions in downlink in band 5 applying a 4 MHz signal (895 MHz – 1 GHz).

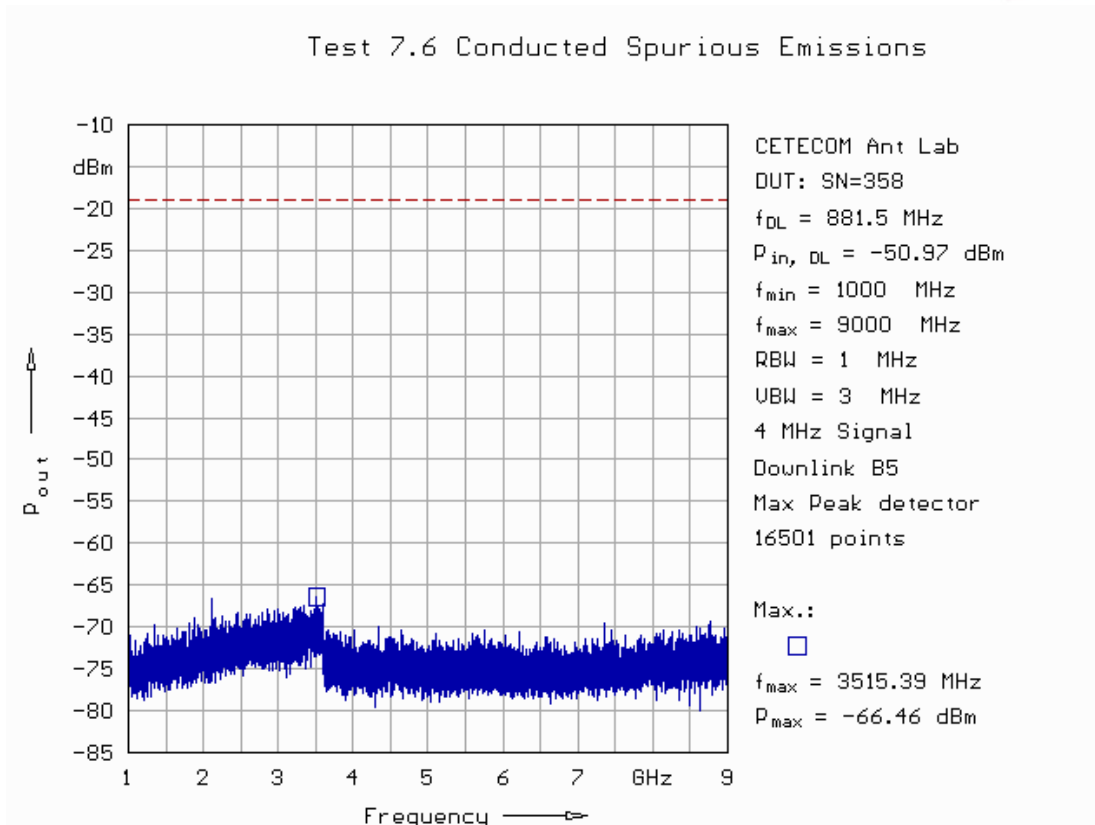

Fig. 147: Conducted spurious emissions in downlink in band 5 applying a 4 MHz signal (1 GHz – 9 GHz).

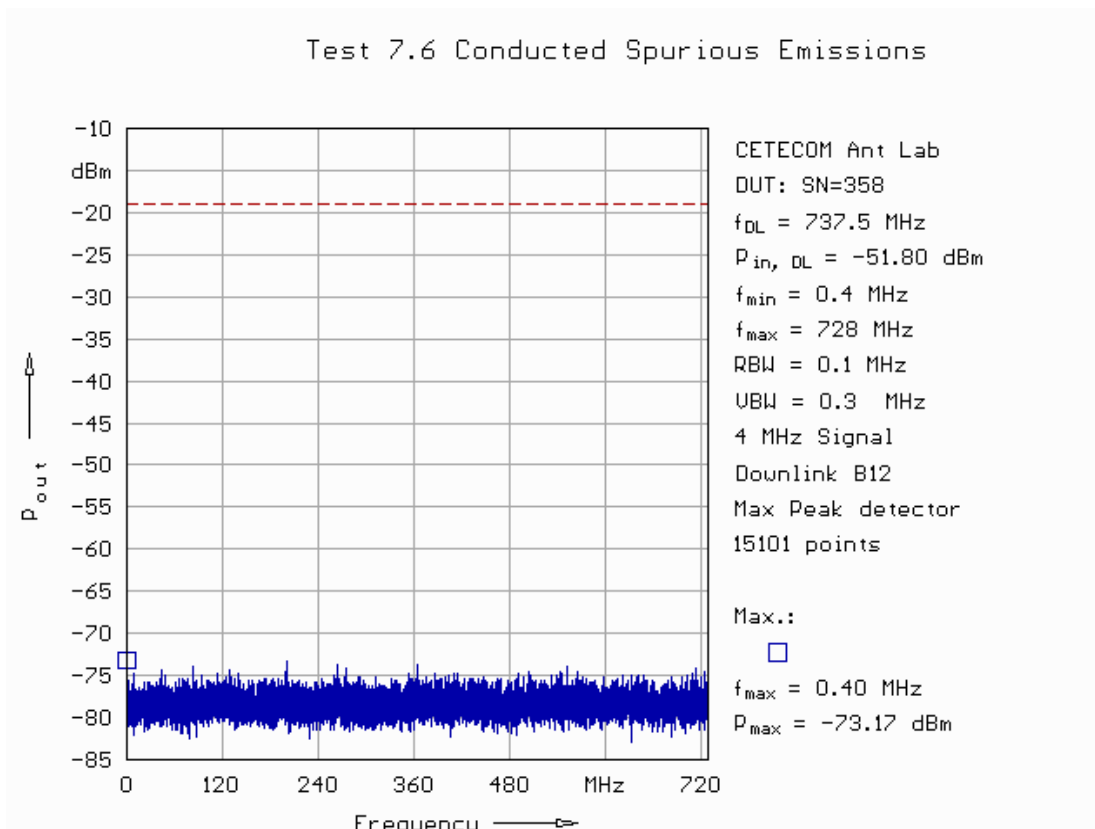

Fig. 148: Conducted spurious emissions in downlink in band 12 applying a 4 MHz signal (0.4 MHz – 728 MHz).

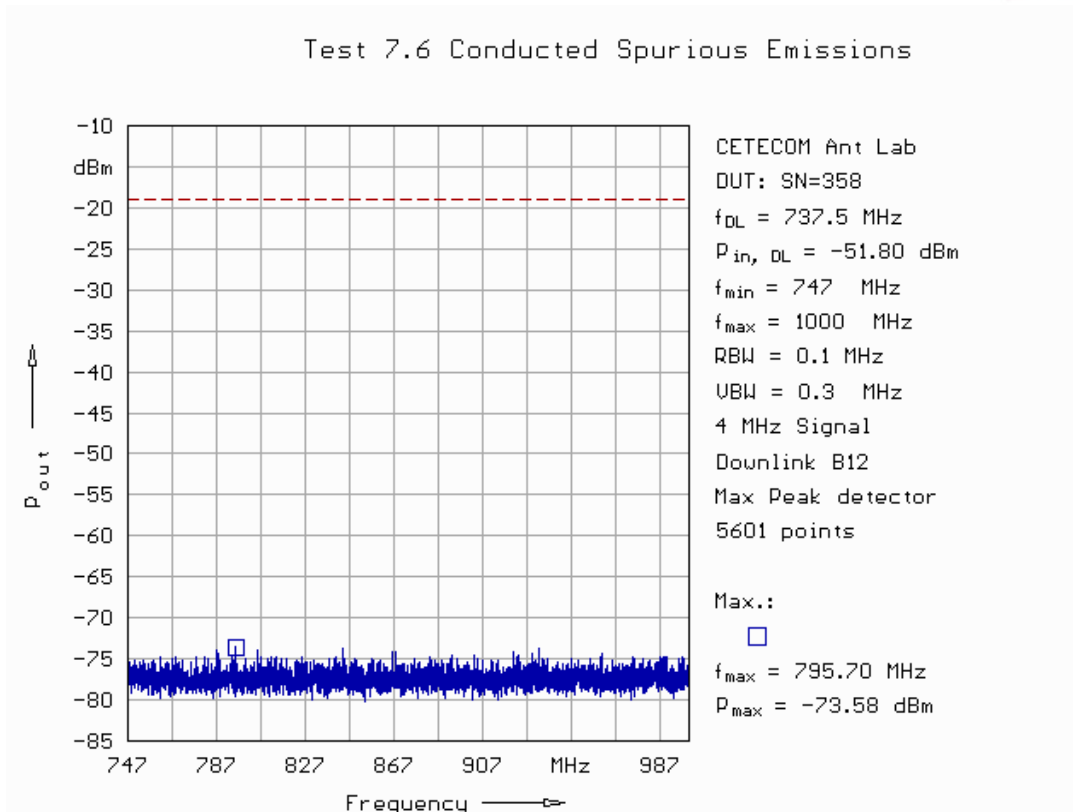

Fig. 149: Conducted spurious emissions in downlink in band 12 applying a 4 MHz signal (747 MHz – 1 GHz).

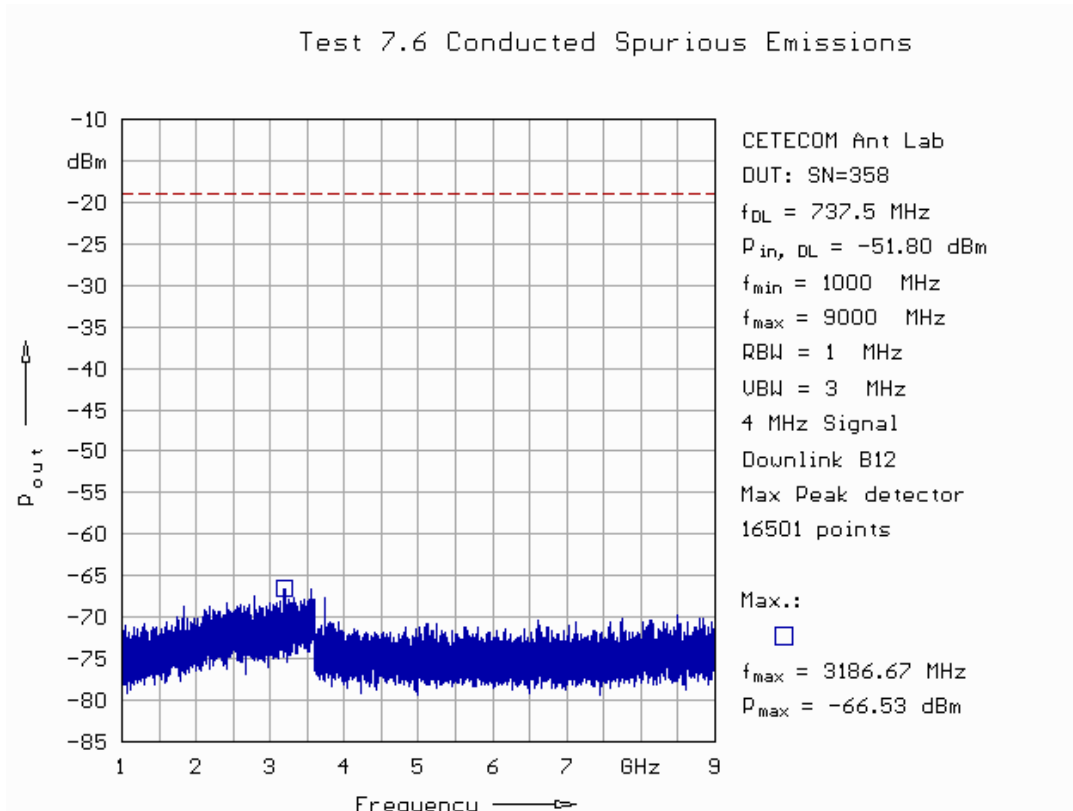

Fig. 150: Conducted spurious emissions in downlink in band 12 applying a 4 MHz signal (1 GHz – 9 GHz).

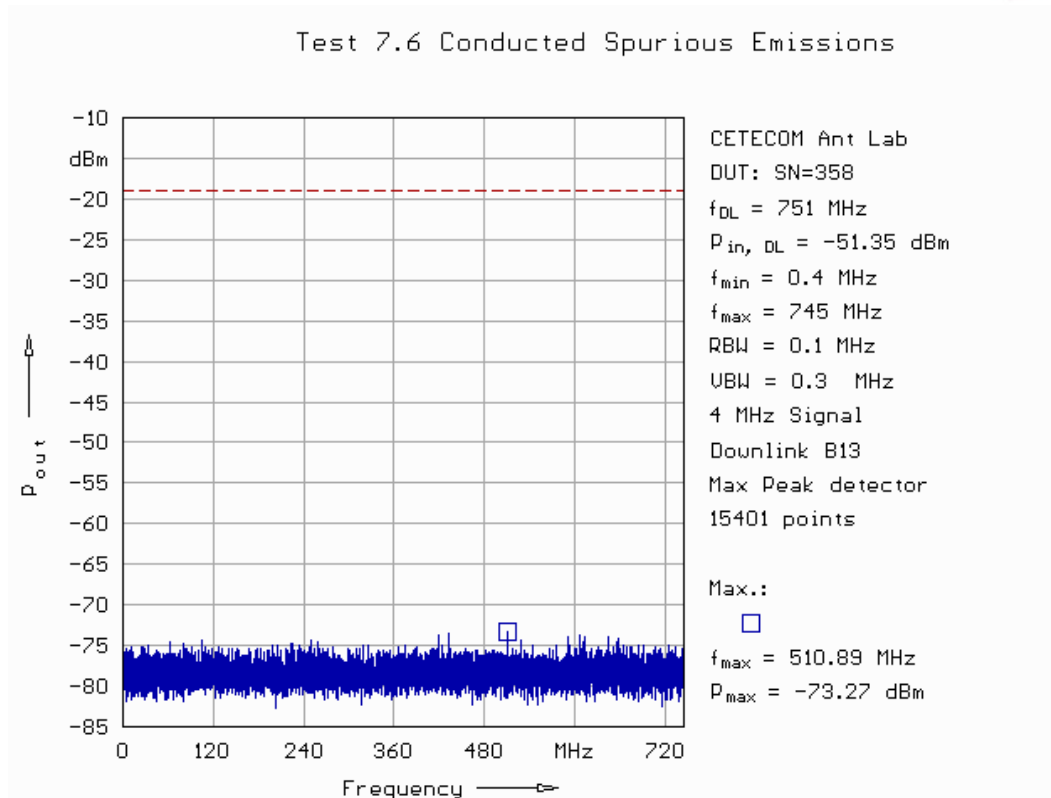

Fig. 151: Conducted spurious emissions in downlink in band 13 applying a 4 MHz signal (0.4 MHz – 745 MHz).

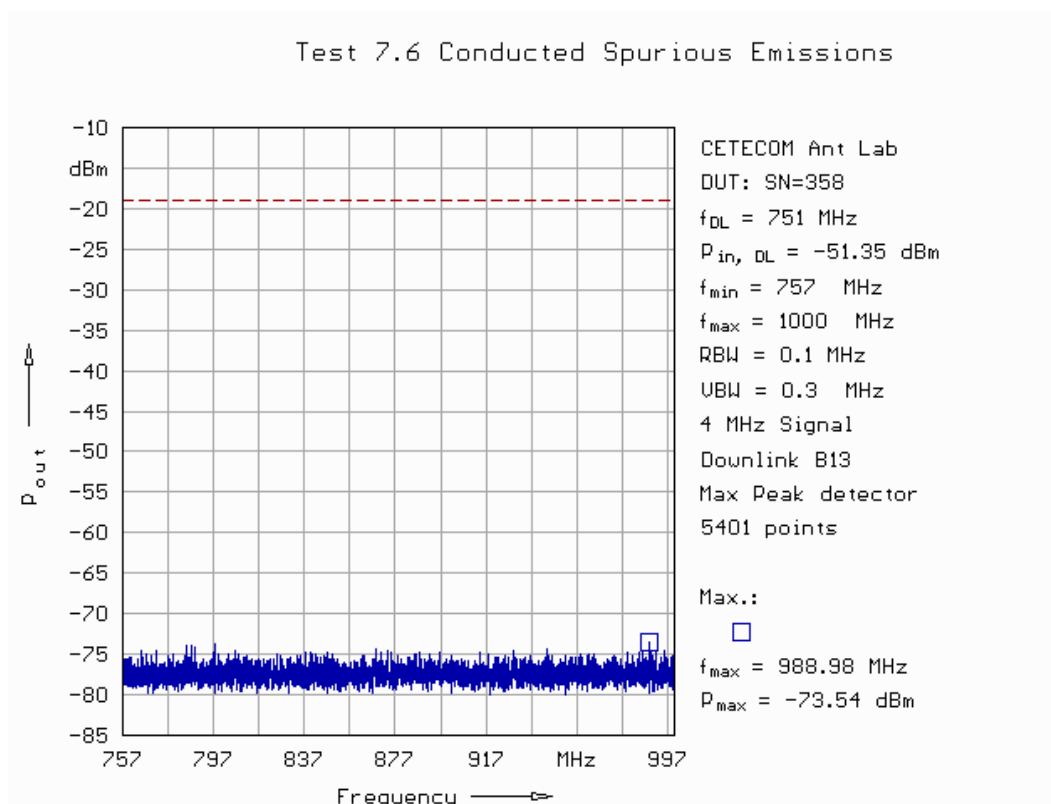

Fig. 152: Conducted spurious emissions in downlink in band 13 applying a 4 MHz signal (757 MHz – 1 GHz).

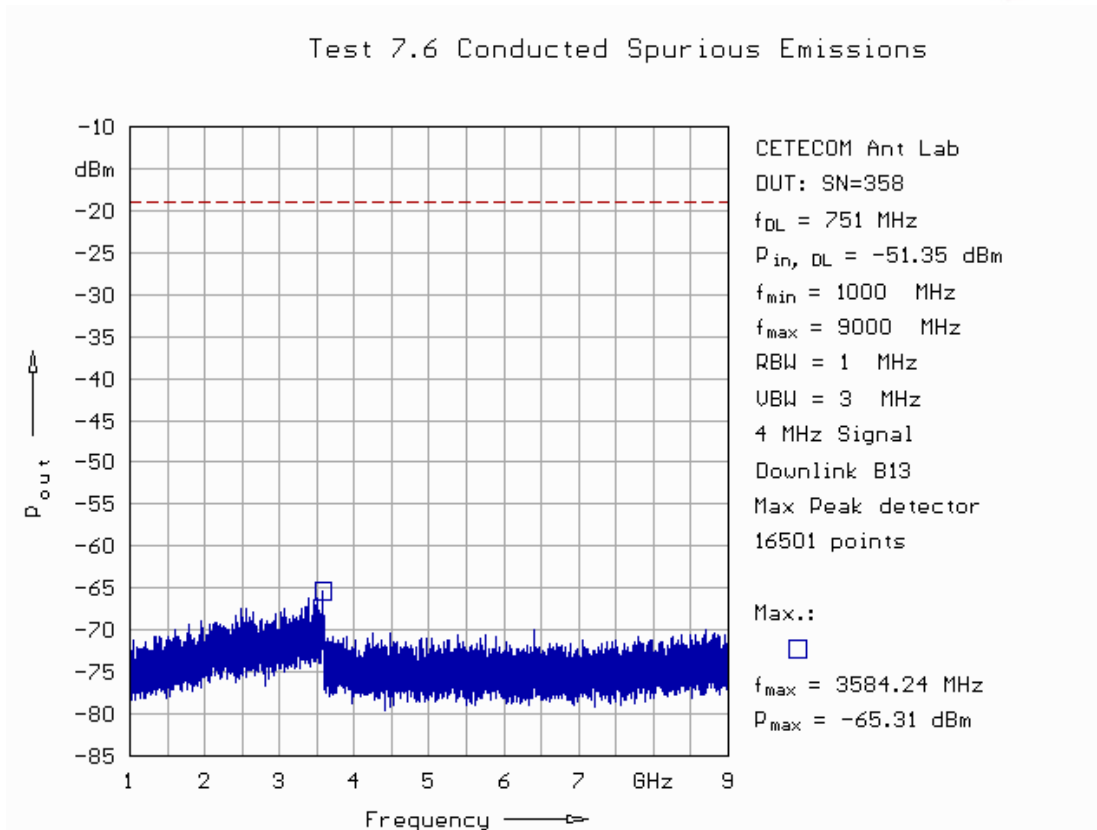

Fig. 153: Conducted spurious emissions in downlink in band 13 applying a 4 MHz signal (1 GHz – 9 GHz).

5.7. Noise

5.7.1 Maximum transmitter noise power level

The activated cable routing for this test in uplink is shown in Fig. 154, Fig. 155, Fig. 157 and for the downlink in Fig. 156, Fig. 158, respectively. For the uplink two scenarios are necessary as shown in Fig. 154 and Fig. 155, because for the special type of booster under test, a stimulating signal is required at the server port to switch ON the uplink amplifier. Additionally the stimulating signal was applied twice: At the lower frequency band edge plus in a second test at the higher edge in order to see the noise in the full frequency range.

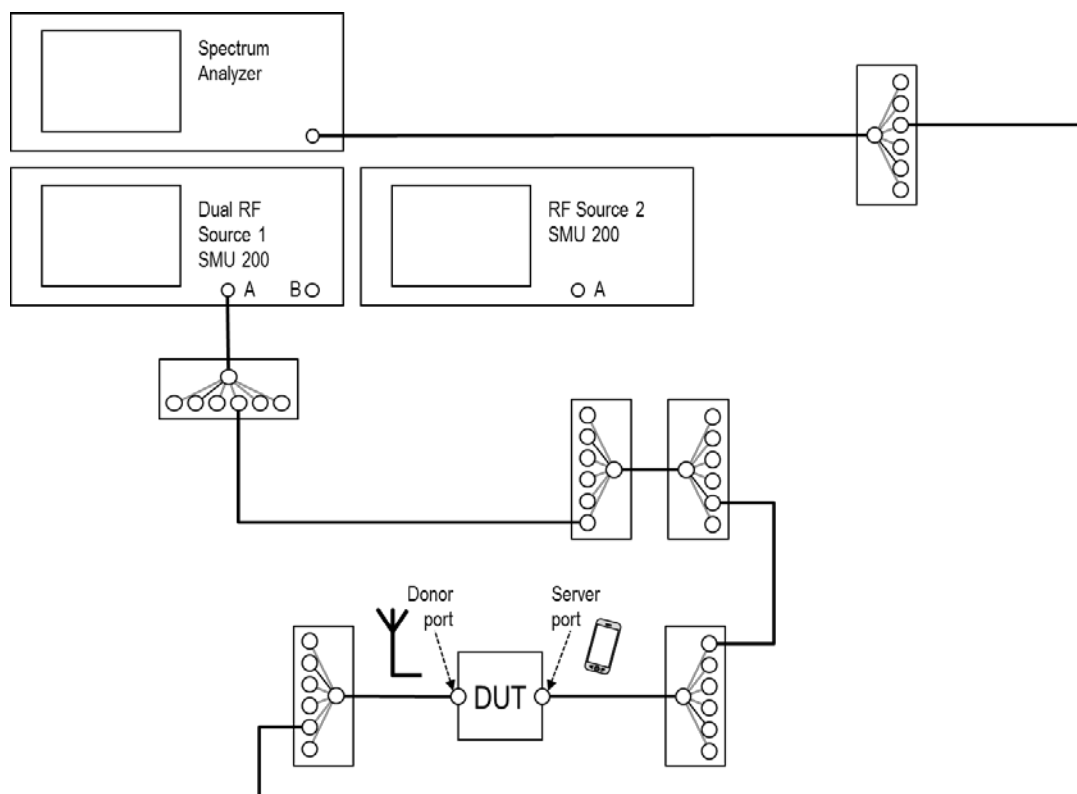

Fig. 154: Set up for the noise test in uplink with uplink activated.

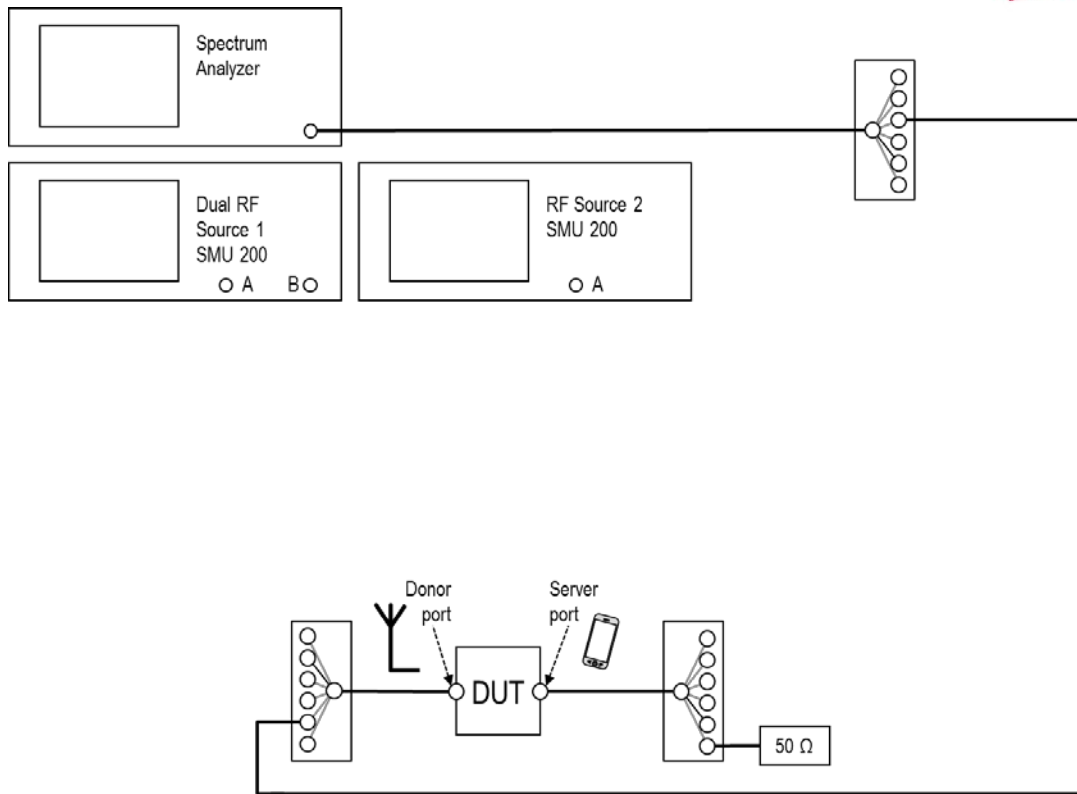

Fig. 155: Set up for the noise test in uplink when in power OFF mode.

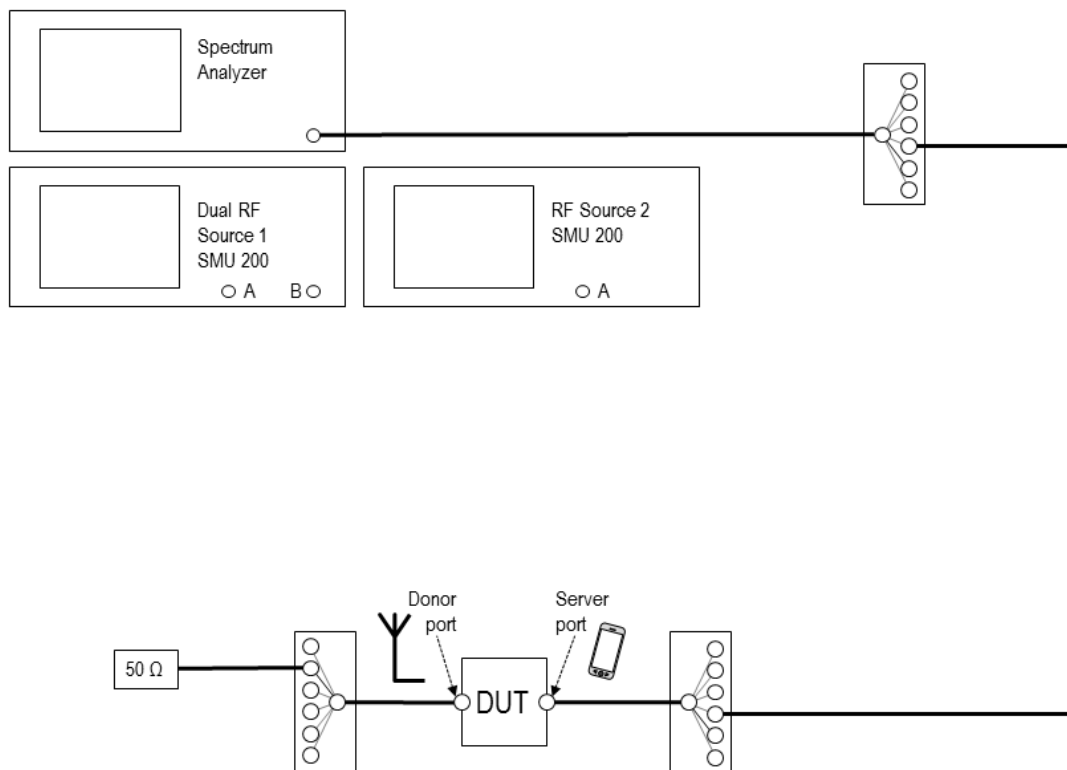

Fig. 156: Set up for the noise test in downlink.

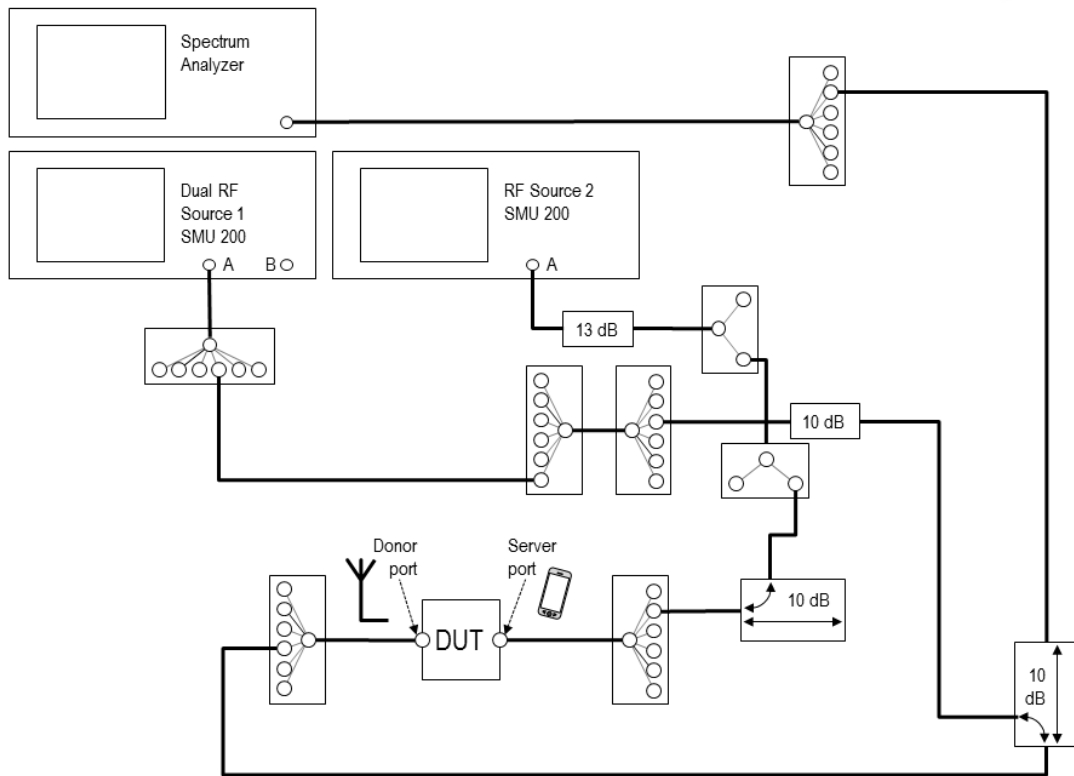

Fig. 157: Set up for the maximum transmitter noise power level test in uplink.

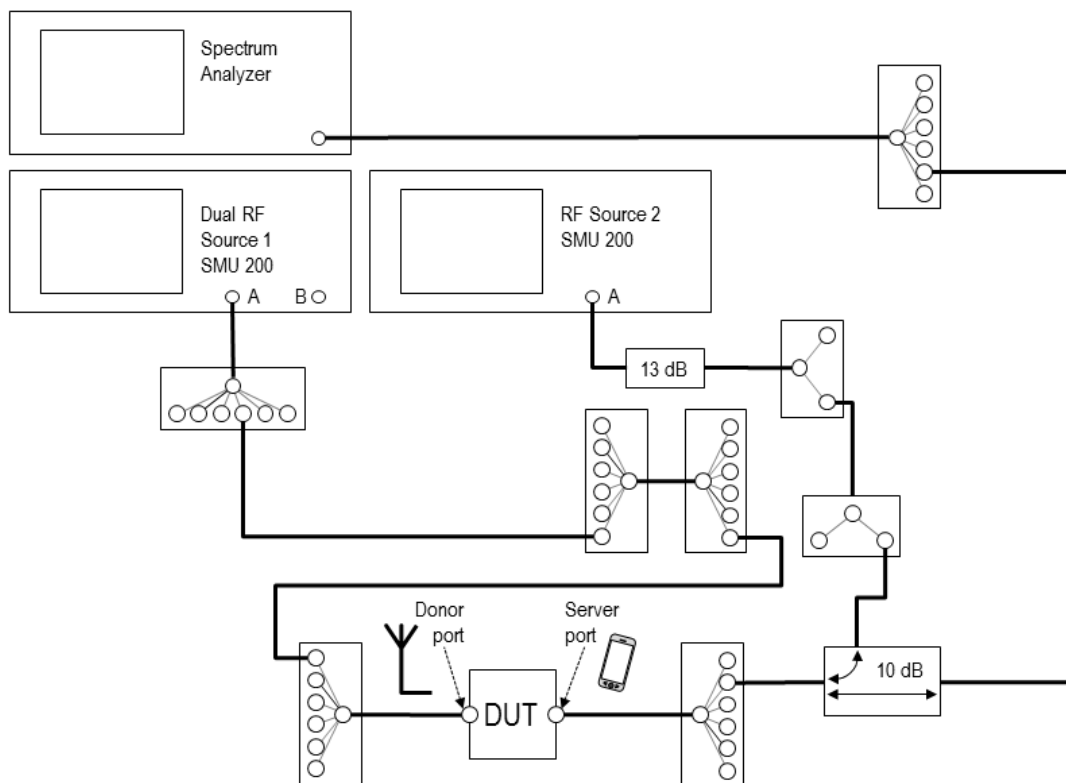

Fig. 158: Set up for the maximum transmitter noise power level test in downlink.

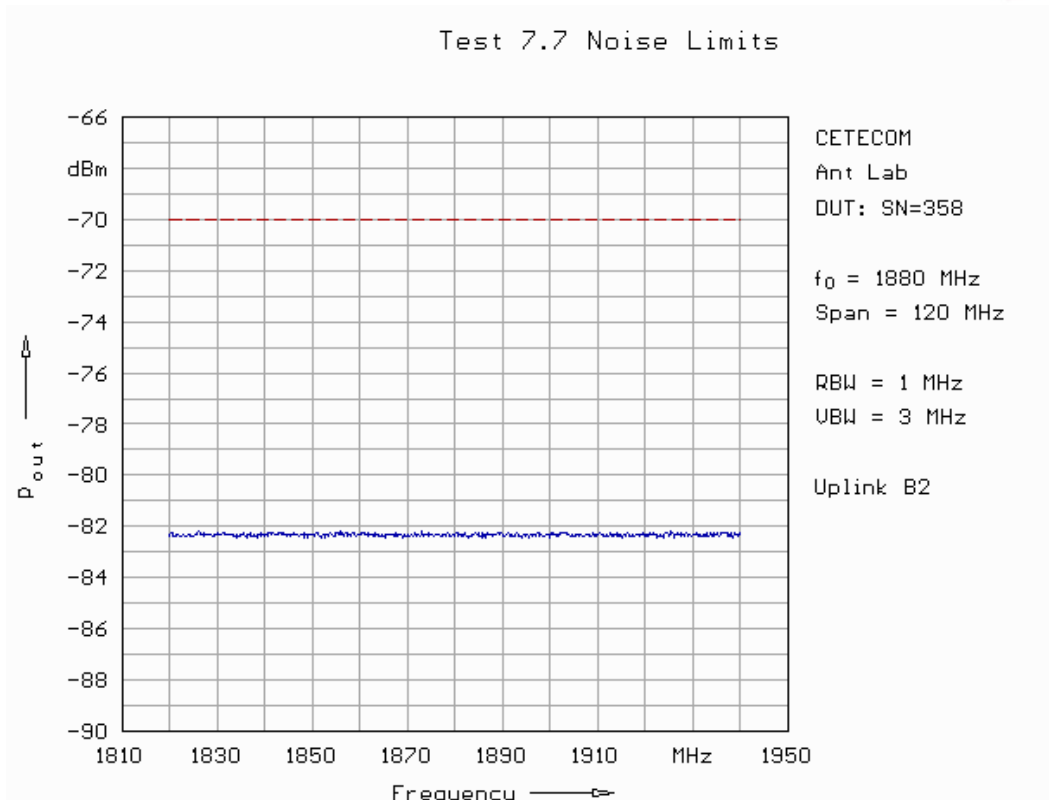

Fig. 159: Noise limits in uplink in band 2 (power off mode).

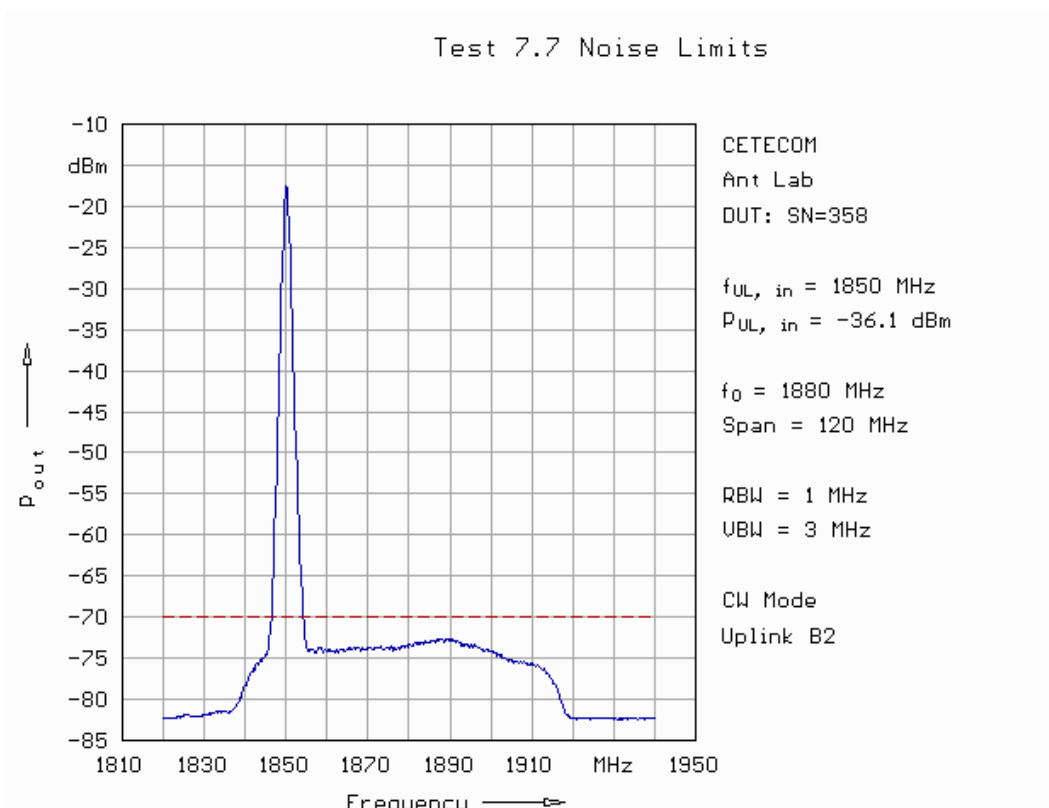

Fig. 160: Noise limits in uplink in band 2 (signal at lower band edge).

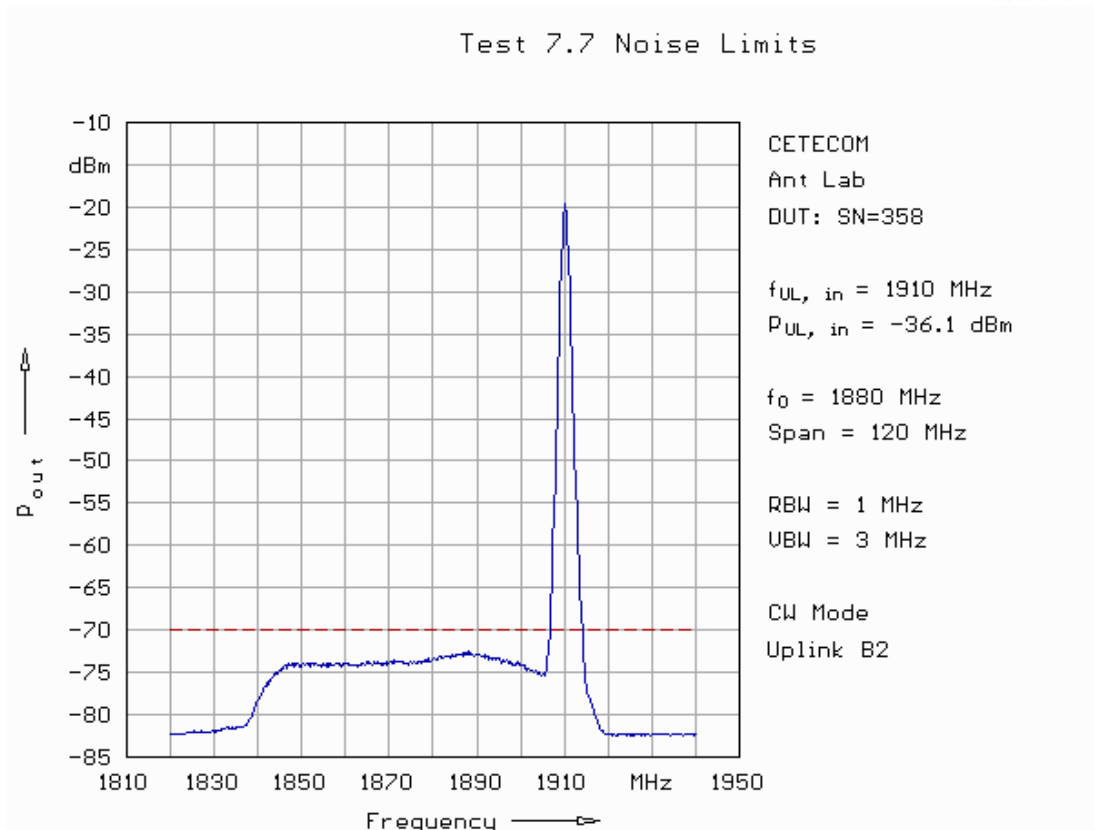

Fig. 161: Noise limits in uplink in band 2 (signal at upper band edge).

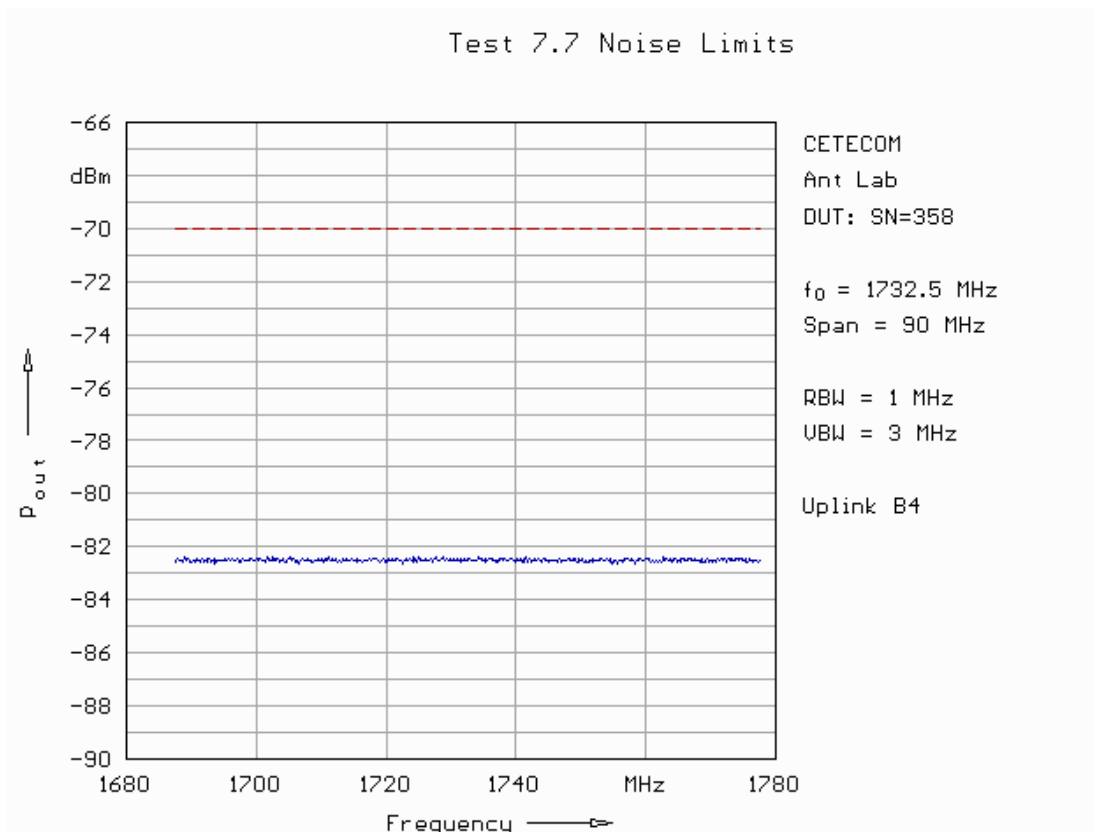

Fig. 162: Noise limits in uplink in band 4 (power off mode).

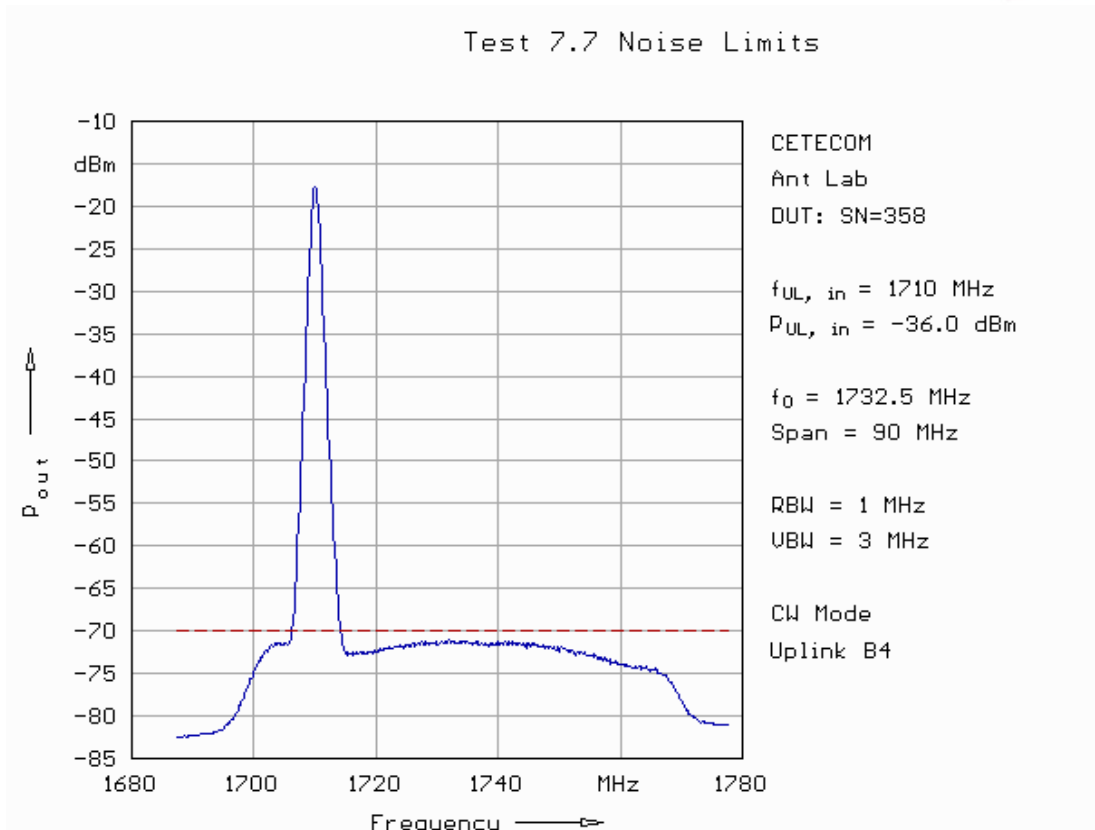

Fig. 163: Noise limits in uplink in band 4 (signal at lower band edge).

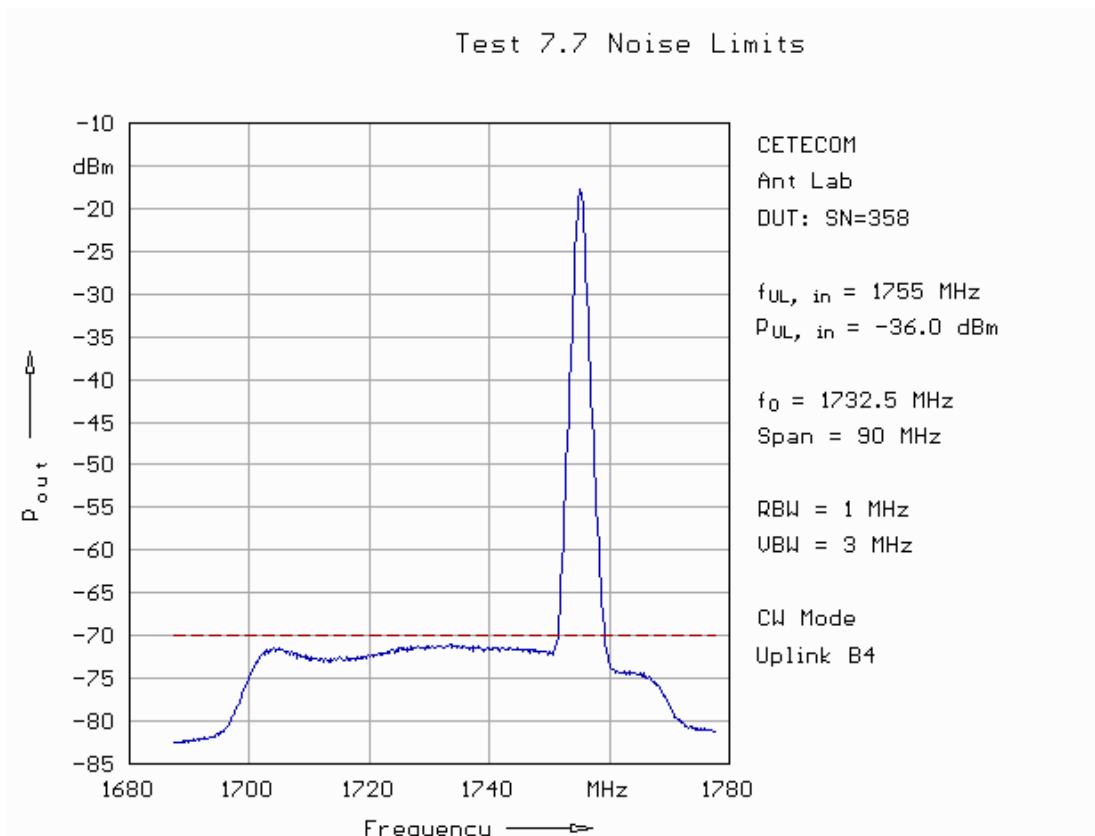

Fig. 164: Noise limits in uplink in band 4 (signal at upper band edge).

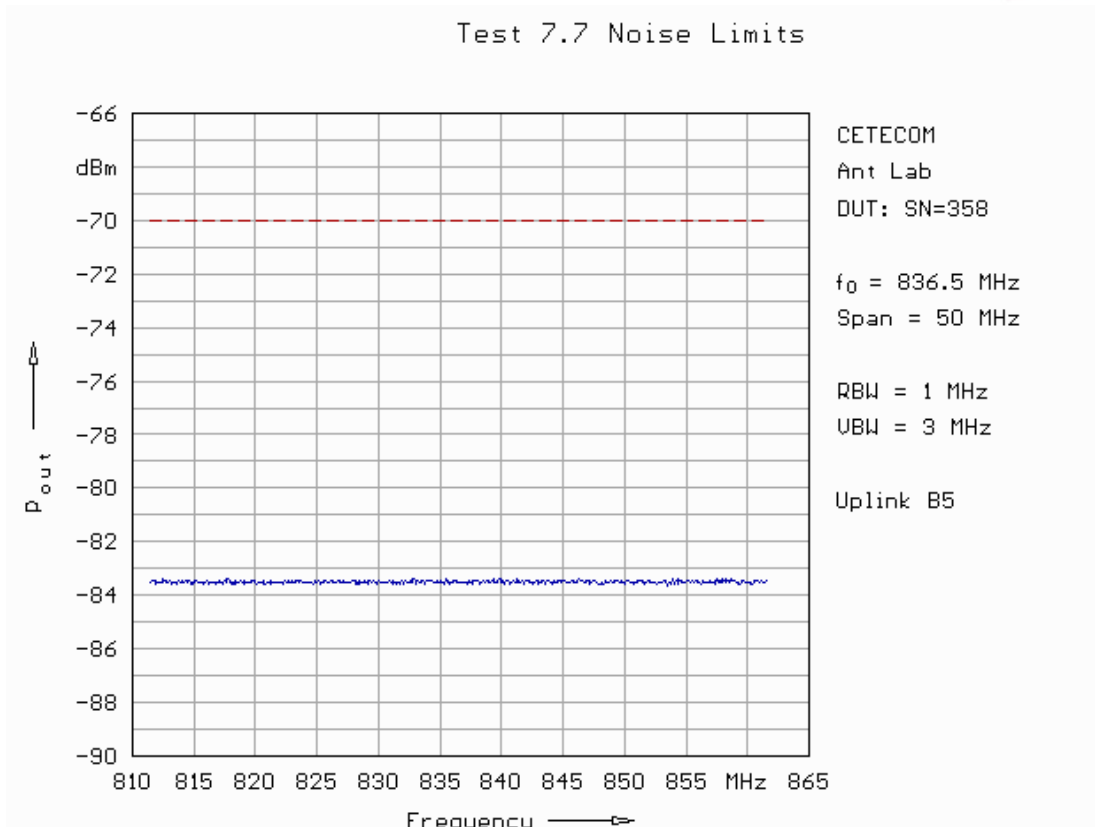

Fig. 165: Noise limits in uplink in band 5 (power off mode).

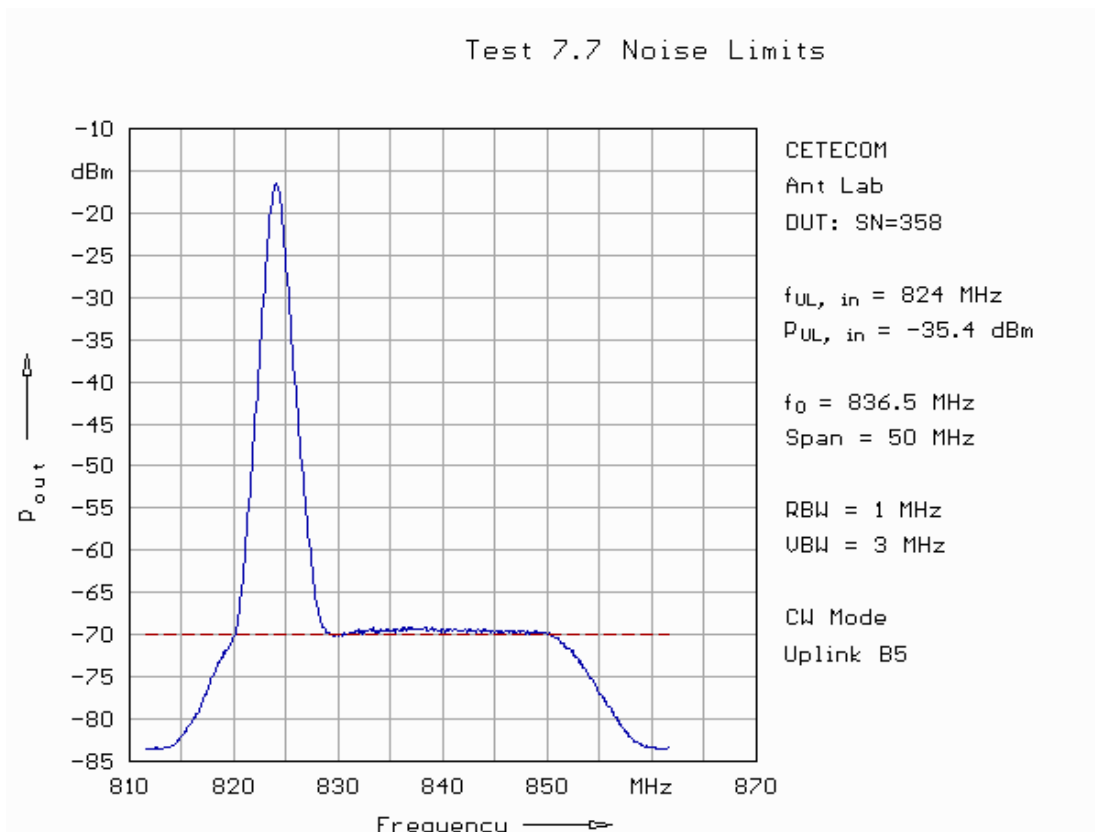

Fig. 166: Noise limits in uplink in band 5 (signal at lower band edge).

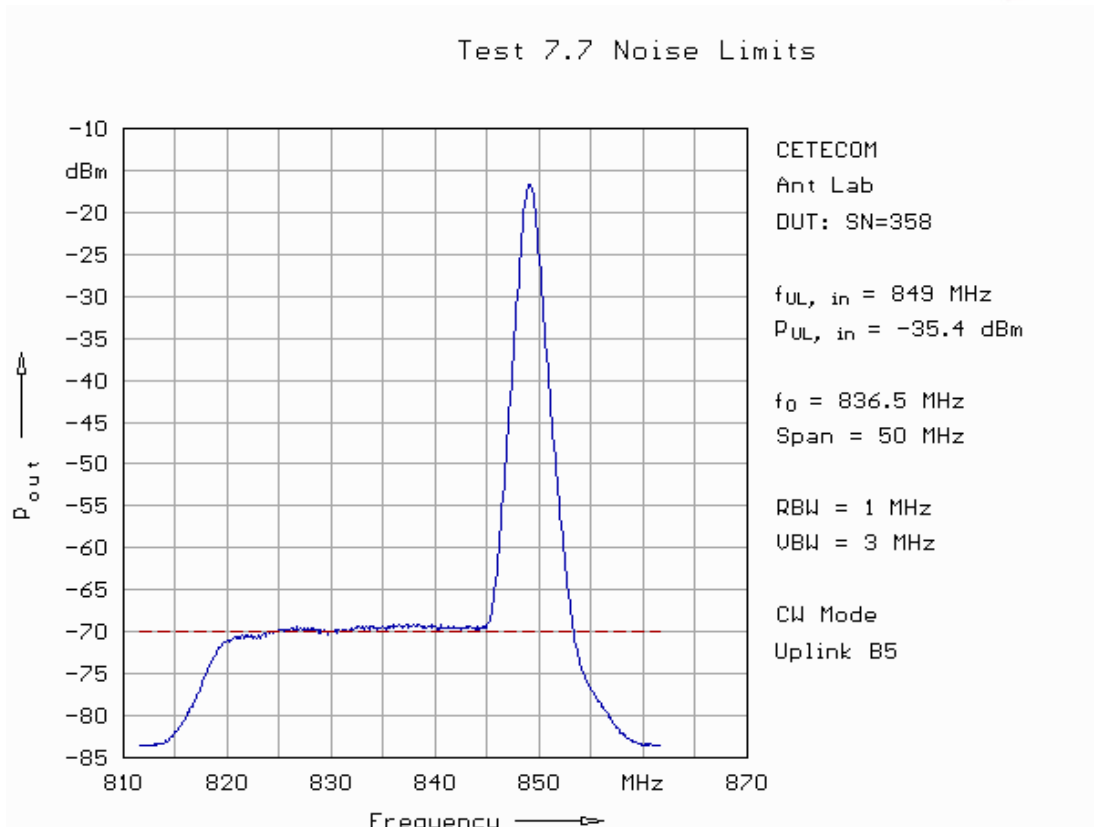

Fig. 167: Noise limits in uplink in band 5 (signal at upper band edge).

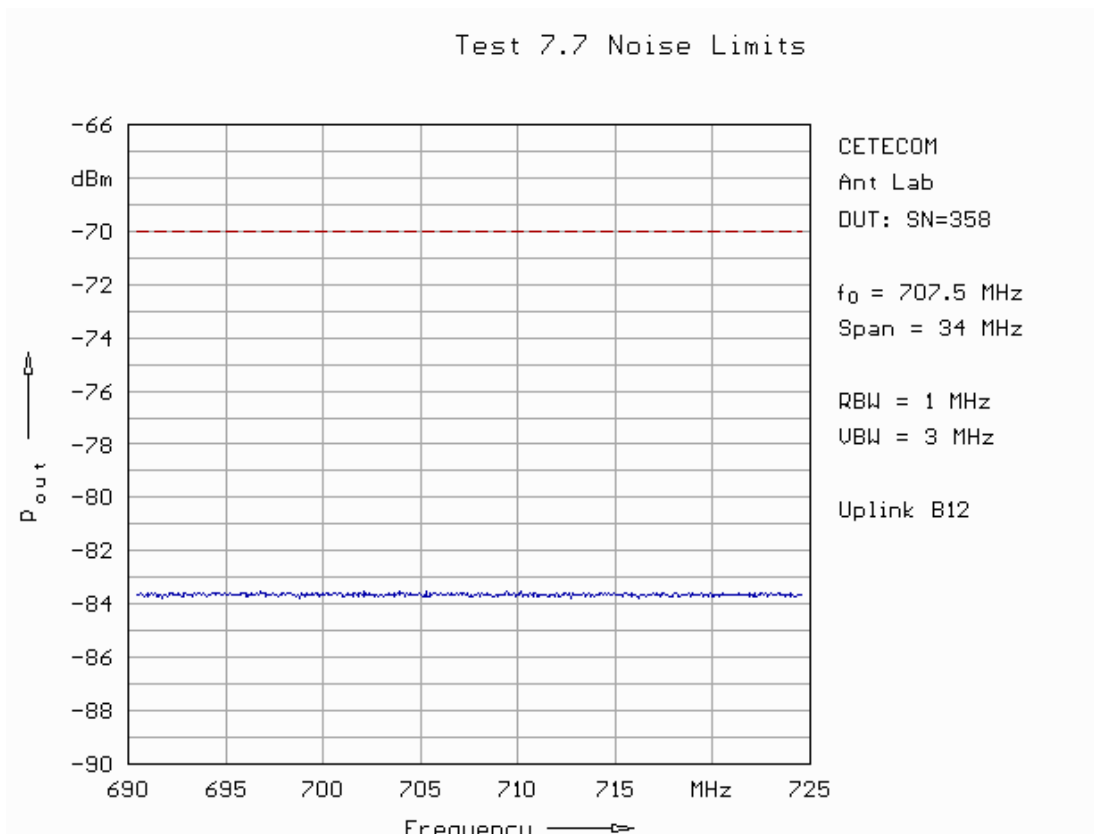

Fig. 168: Noise limits in uplink in band 12 (power off mode).

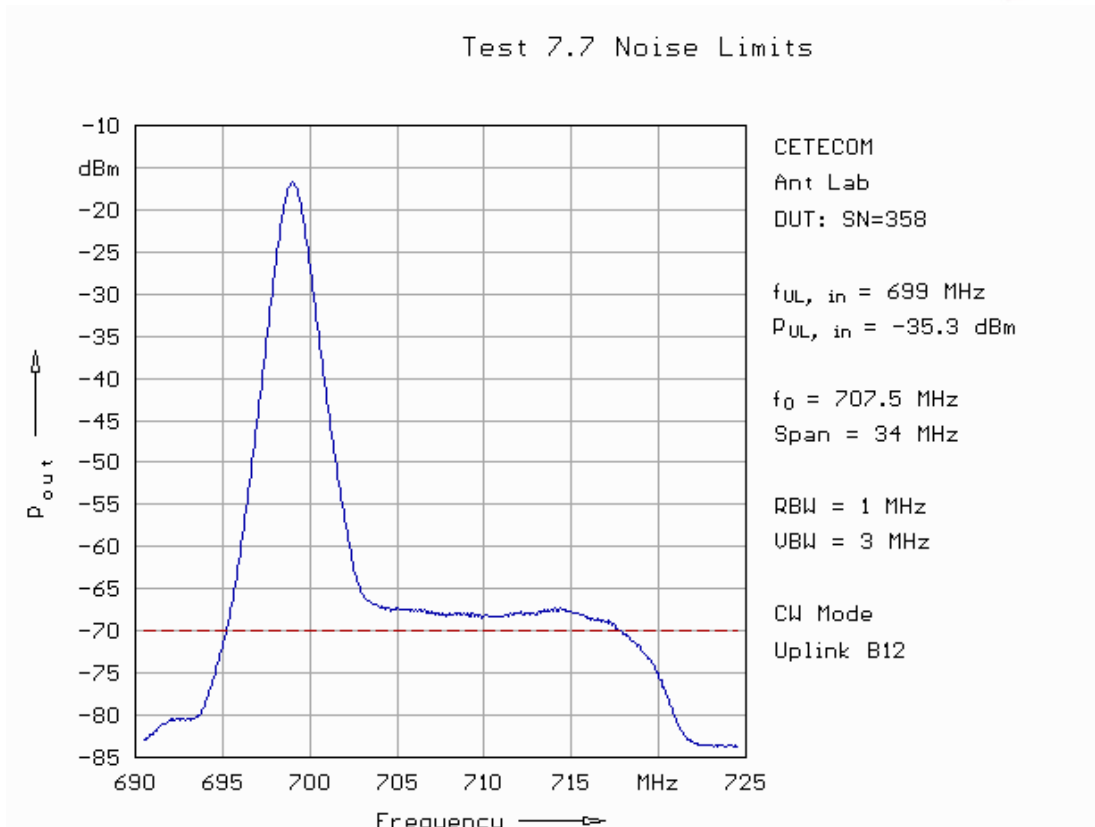

Fig. 169: Noise limits in uplink in band 12 (signal at lower band edge).

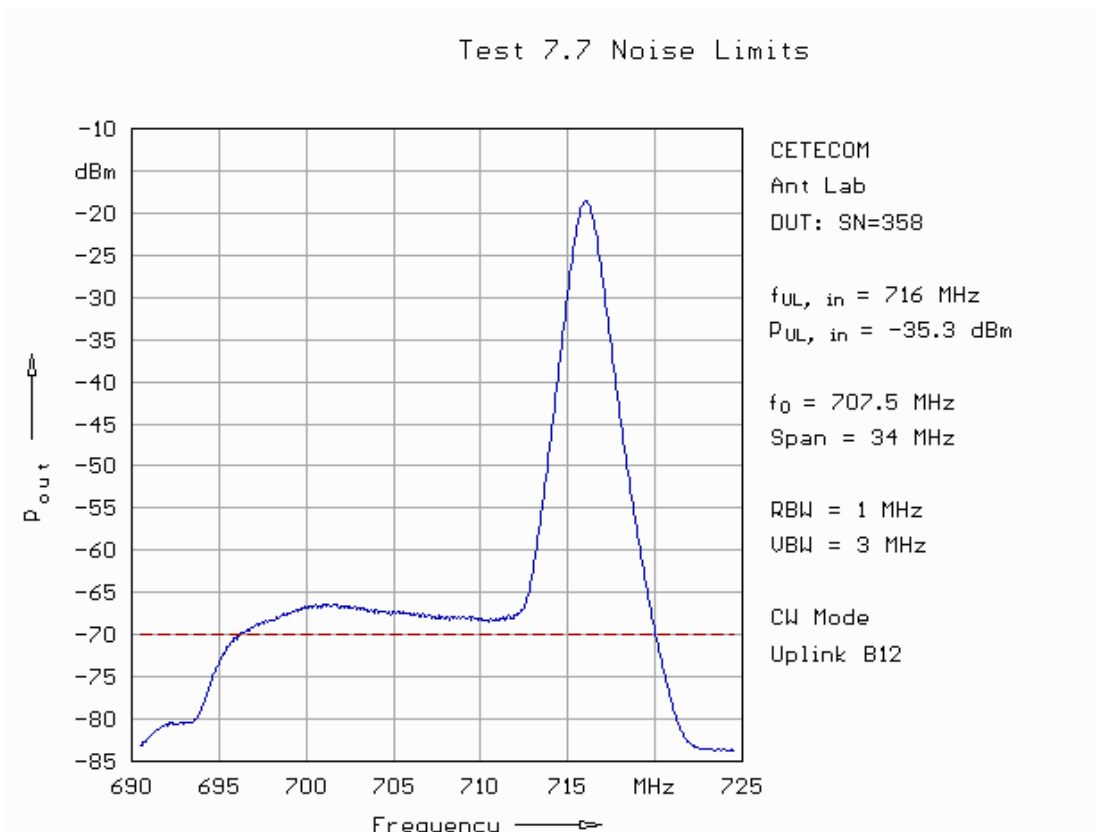

Fig. 170: Noise limits in uplink in band 12 (signal at upper band edge).

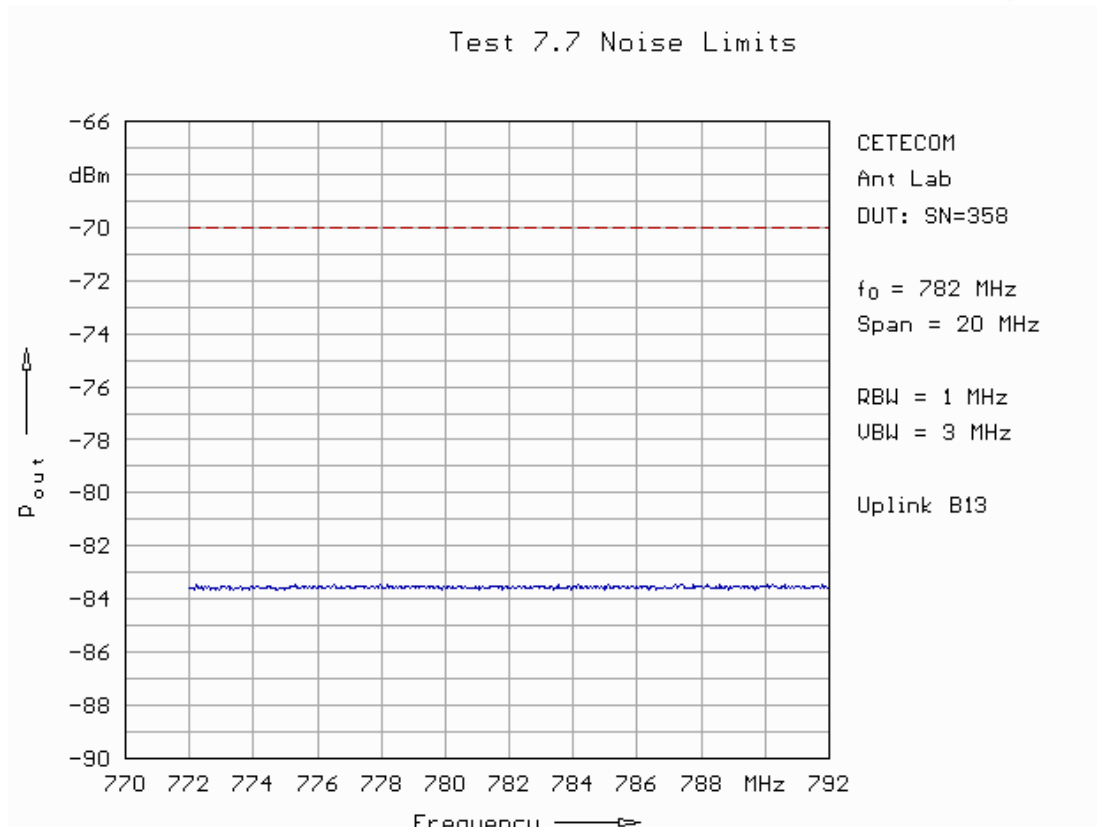

Fig. 171: Noise limits in uplink in band 13 (power off mode).

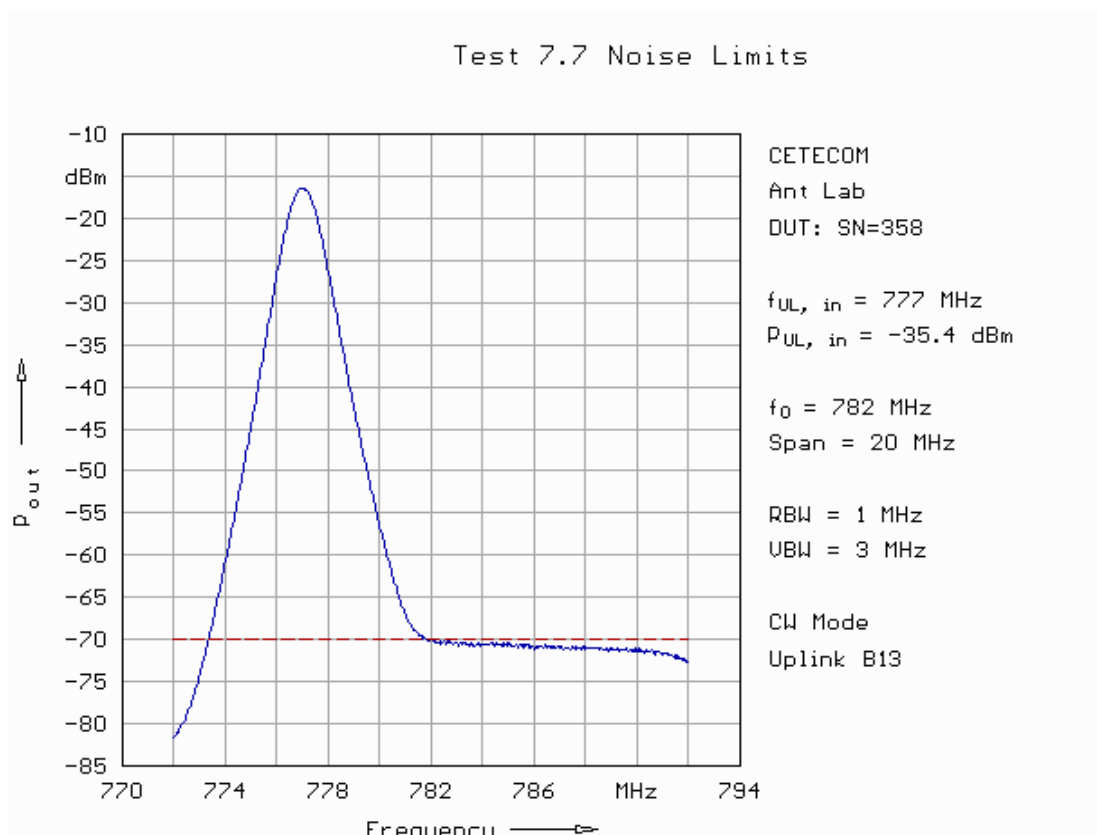

Fig. 172: Noise limits in uplink in band 13 (signal at lower band edge).

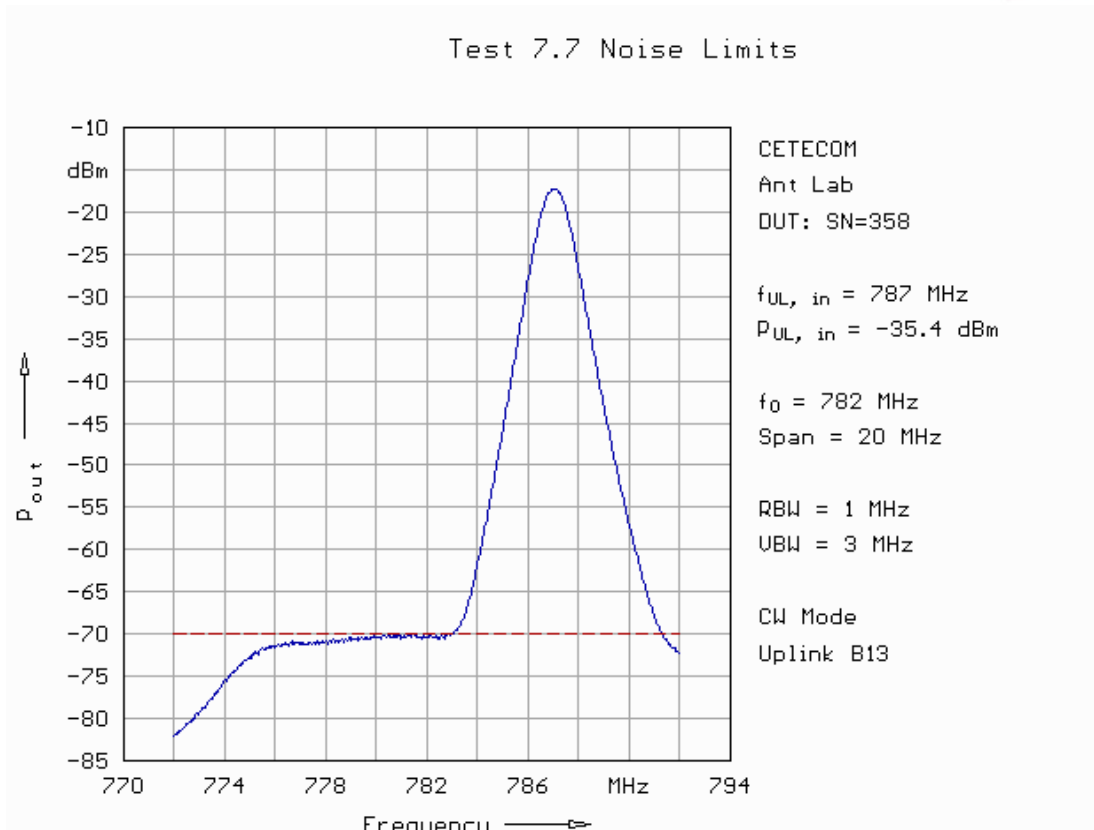

Fig. 173: Noise limits in uplink in band 13 (signal at upper band edge).

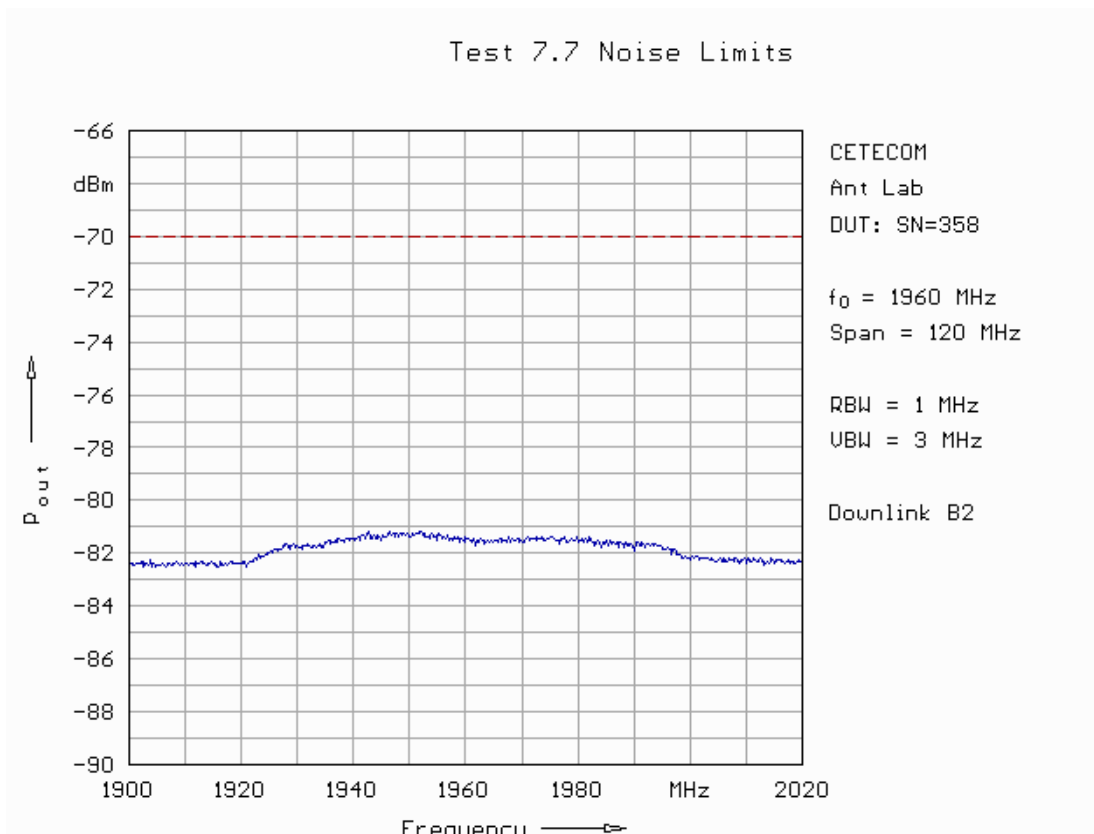

Fig. 174: Noise limits in downlink in band 2 (power off mode).

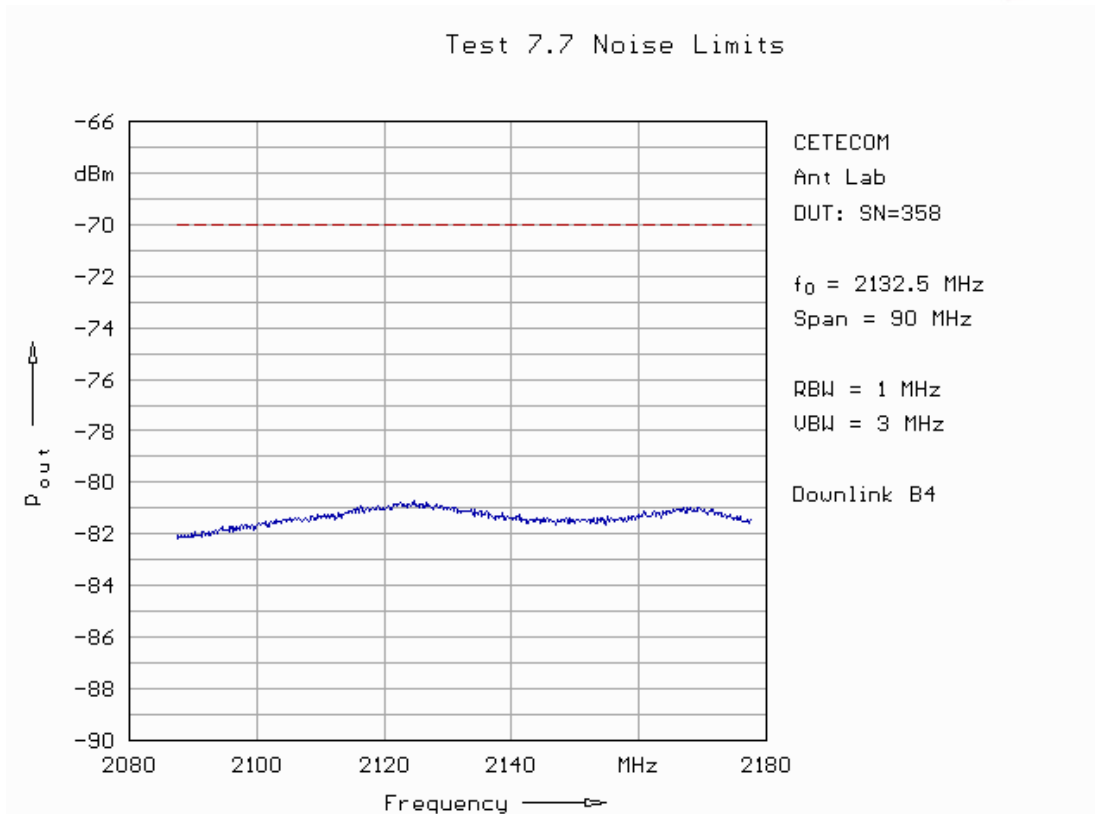

Fig. 175: Noise limits in downlink in band 4 (power off mode).

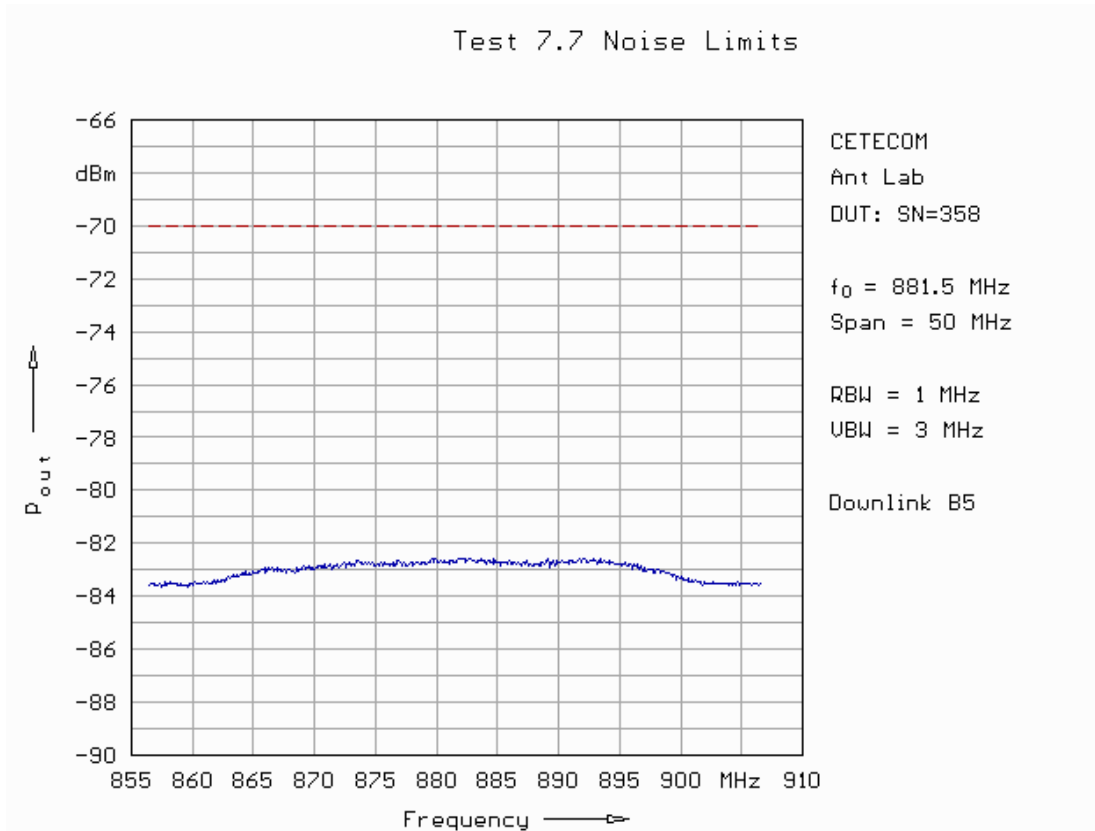

Fig. 176: Noise limits in downlink in band 5 (power off mode).

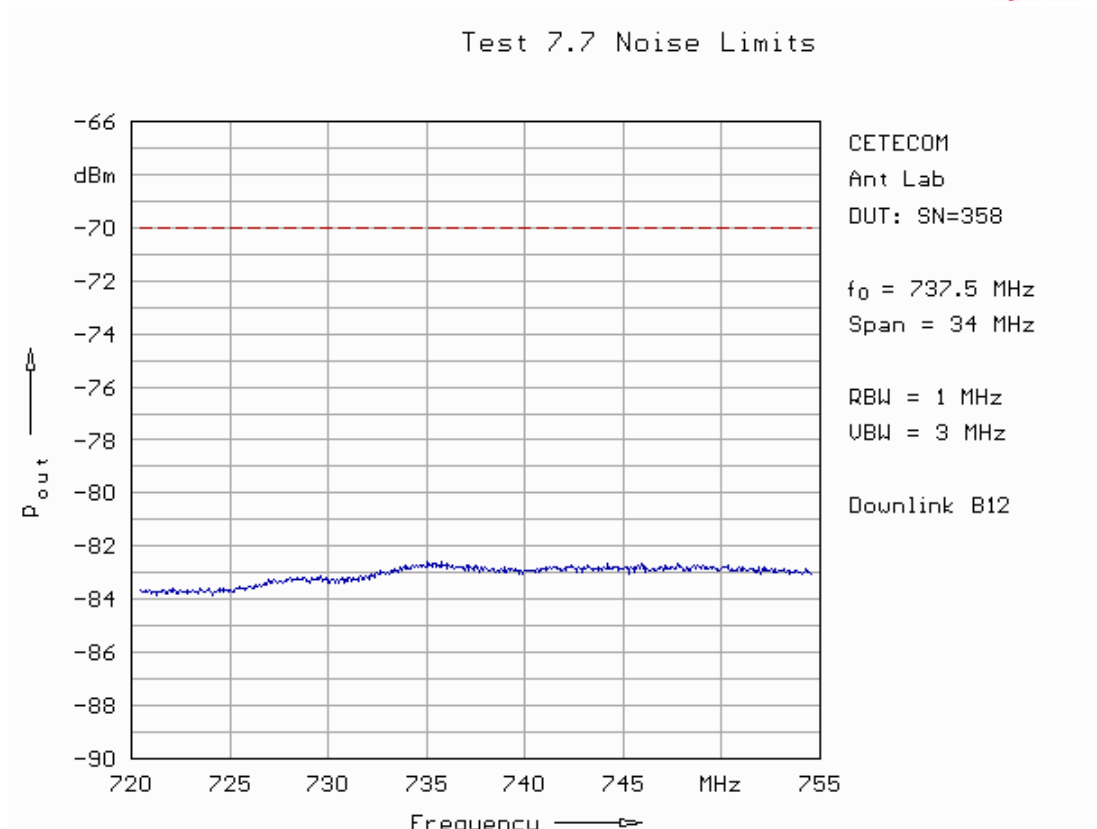

Fig. 177: Noise limits in downlink in band 12 (power off mode).

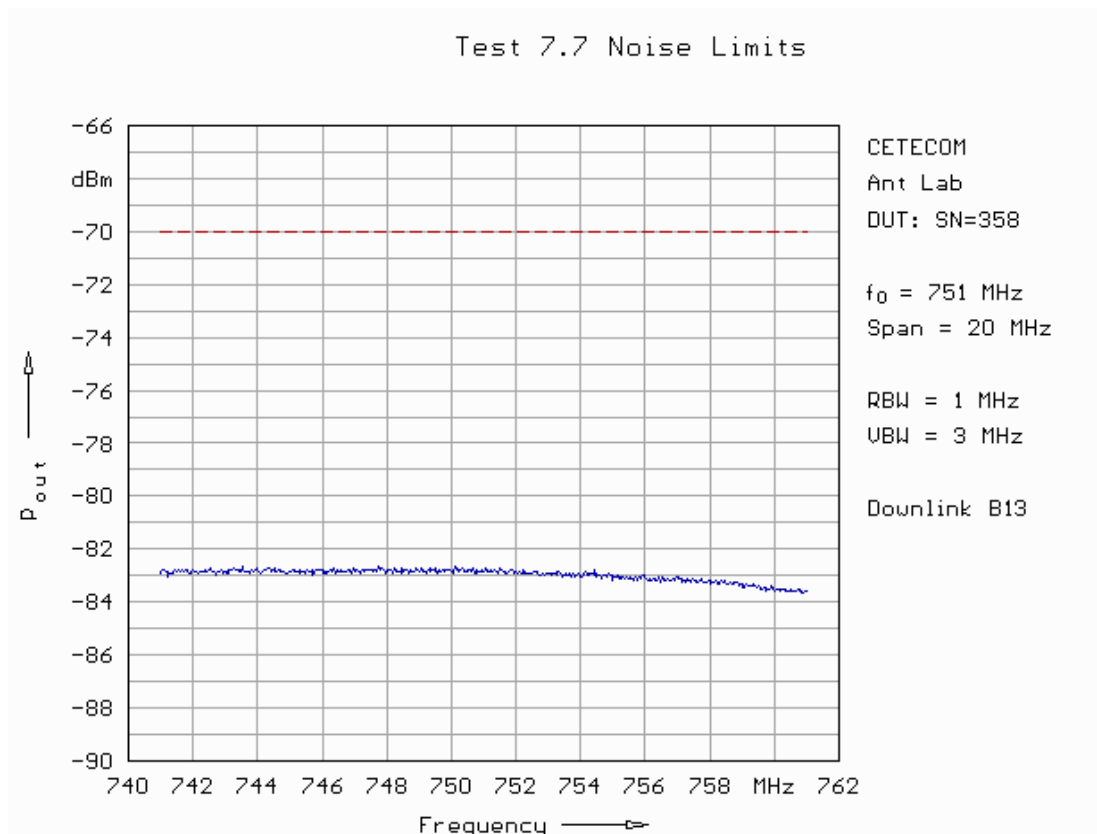

Fig. 178: Noise limits in downlink in band 13 (power off mode).

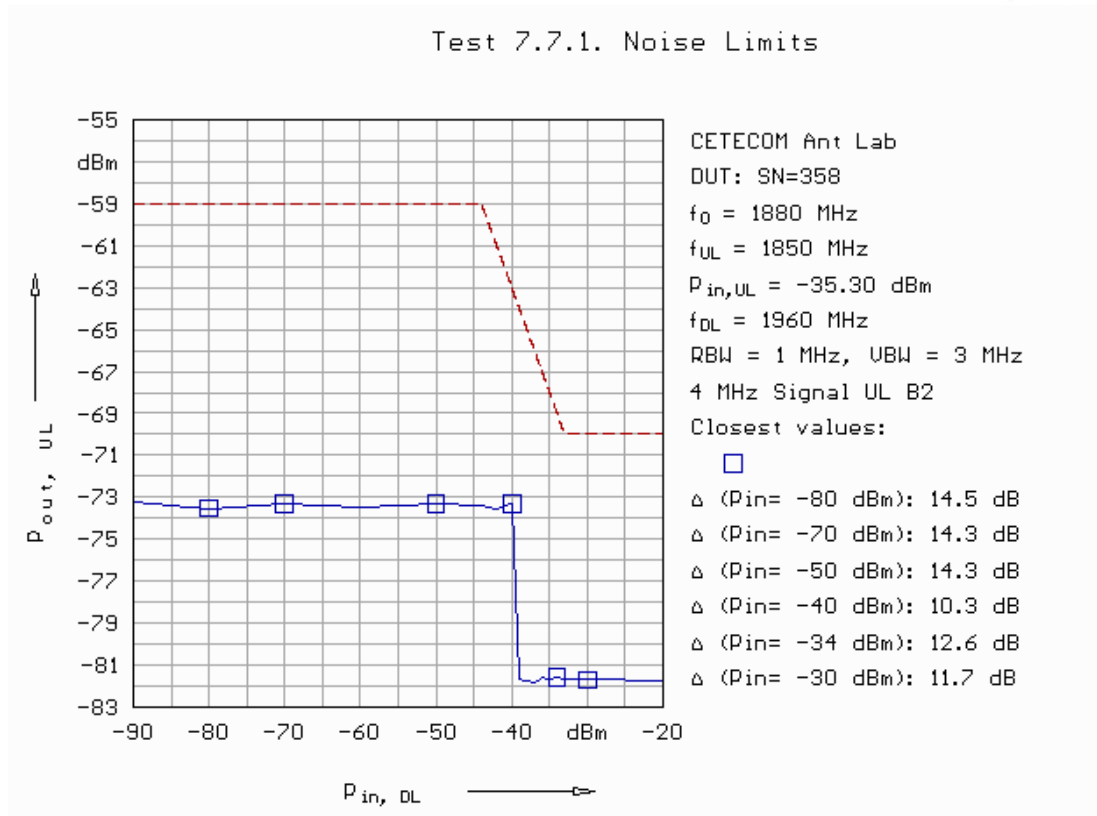

Fig. 179: Maximum transmitter noise power level in uplink in band 2.

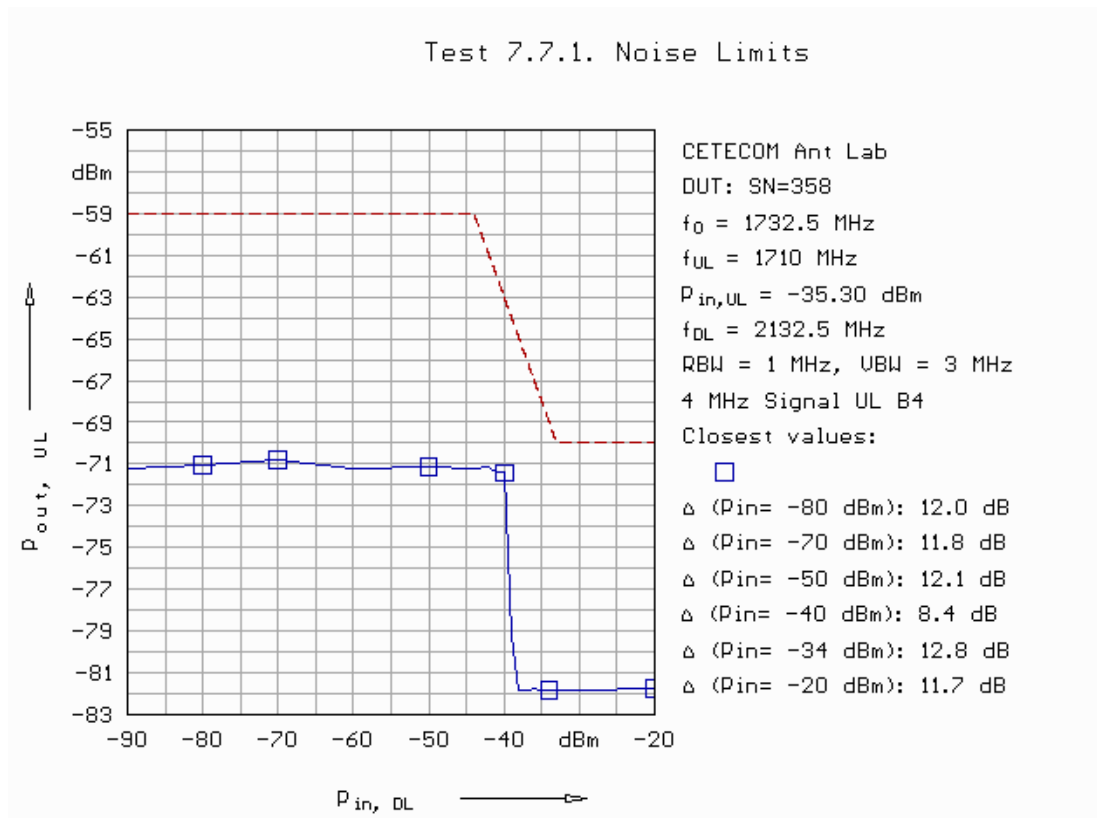

Fig. 180: Maximum transmitter noise power level in uplink in band 4.

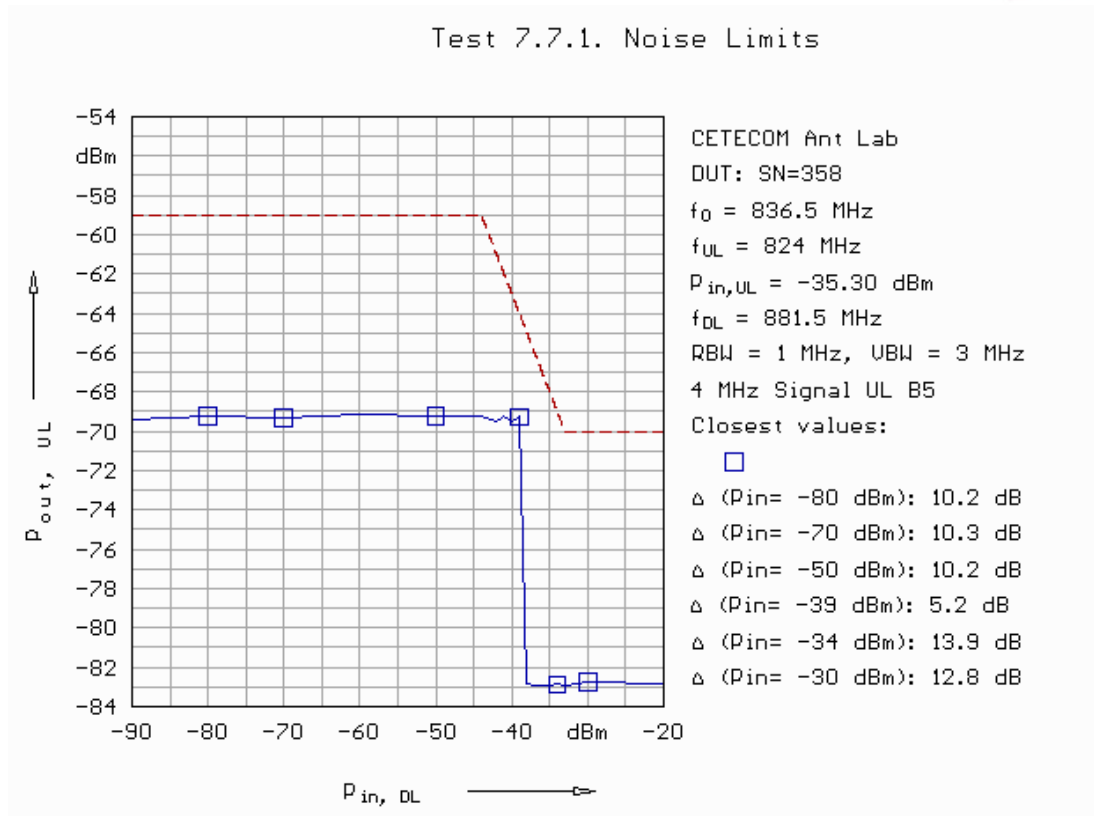

Fig. 181: Maximum transmitter noise power level in uplink in band 5.

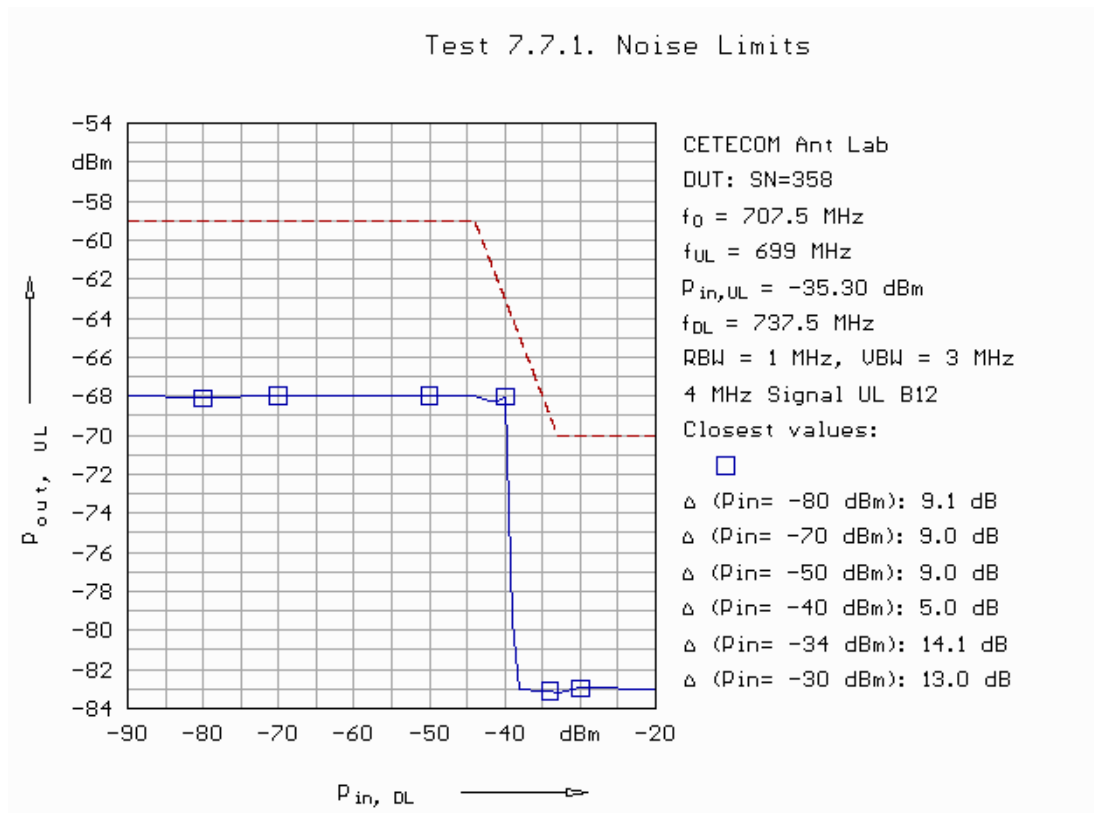

Fig. 182: Maximum transmitter noise power level in uplink in band 12.

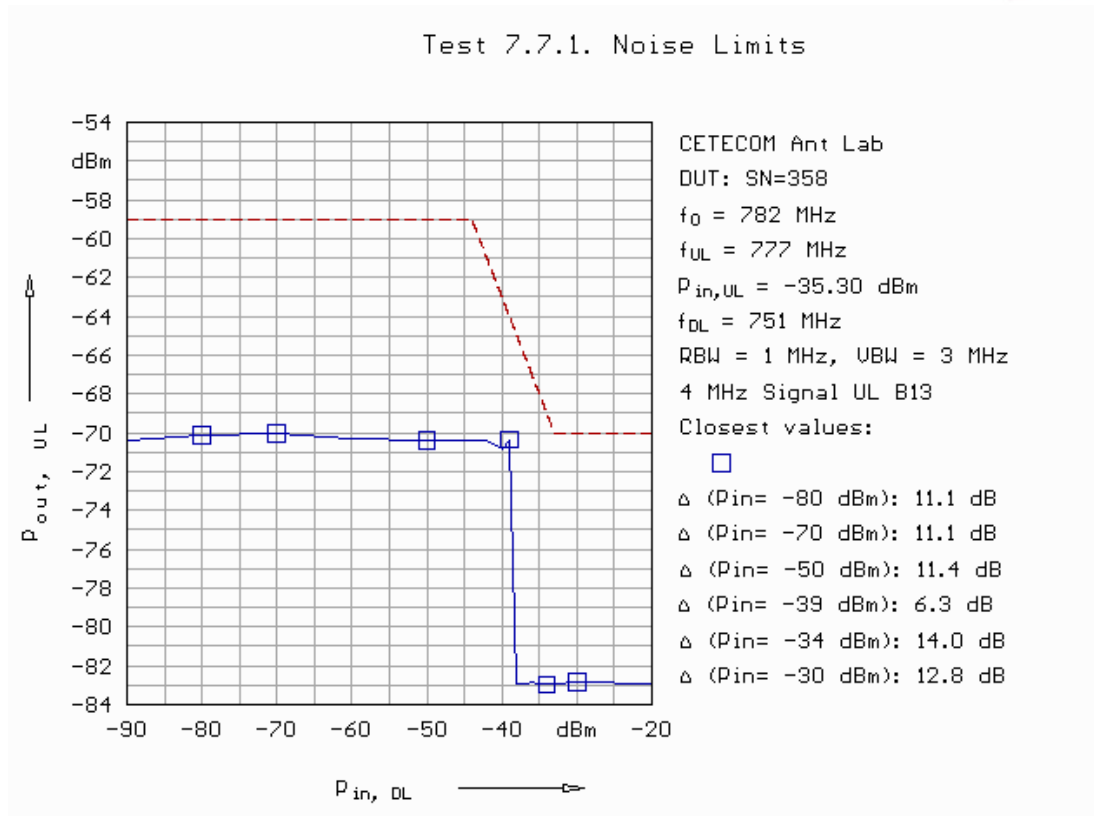

Fig. 183: Maximum transmitter noise power level in uplink in band 13.

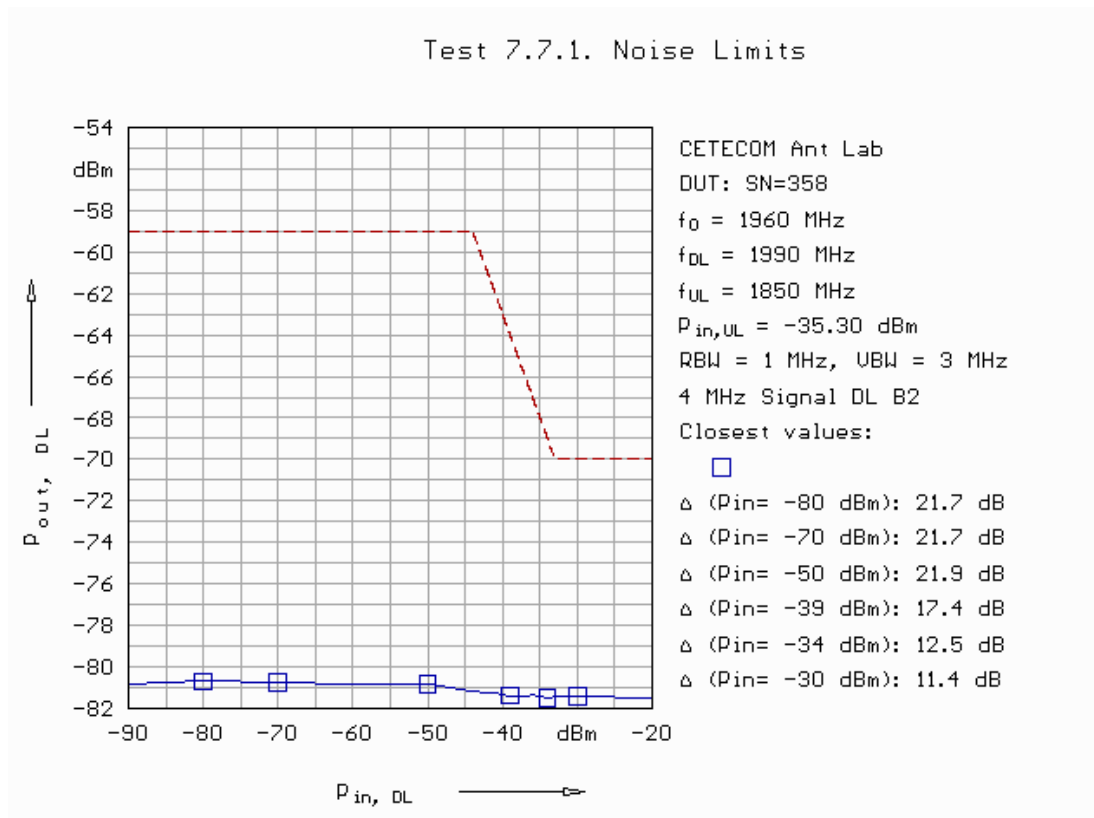

Fig. 184: Maximum transmitter noise power level in downlink in band 2.

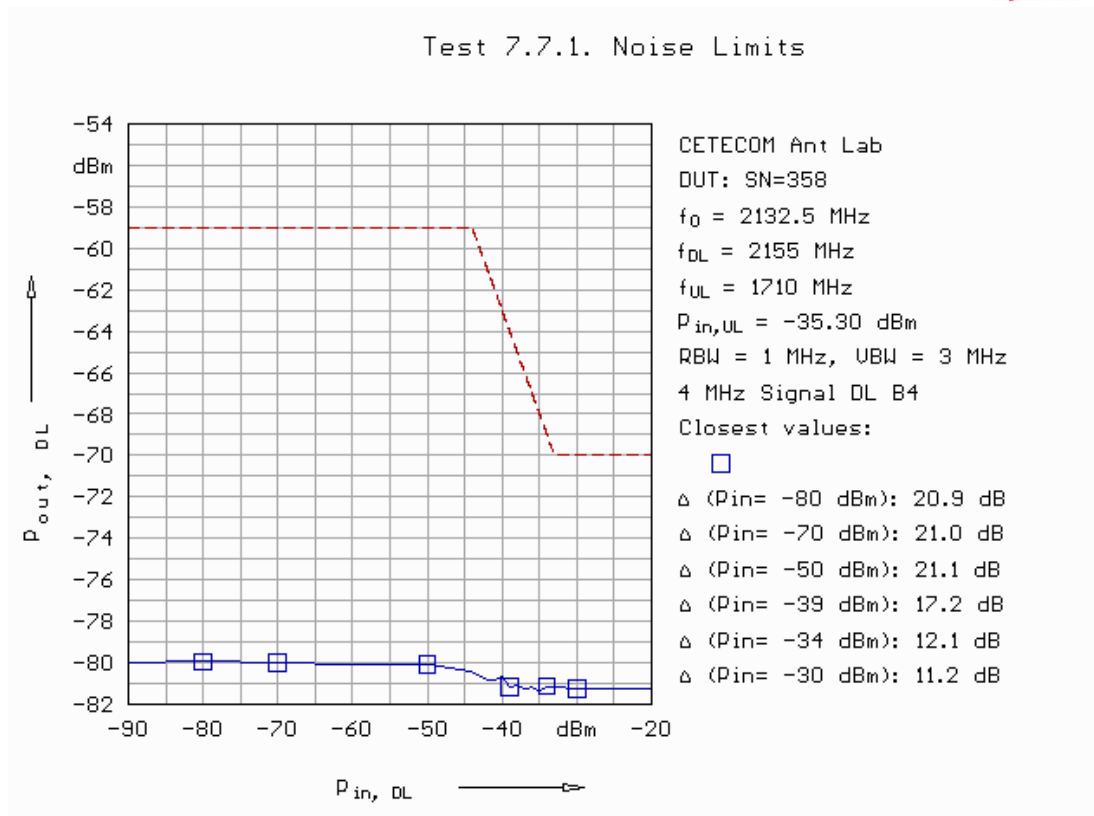

Fig. 185: Maximum transmitter noise power level in downlink in band 4.

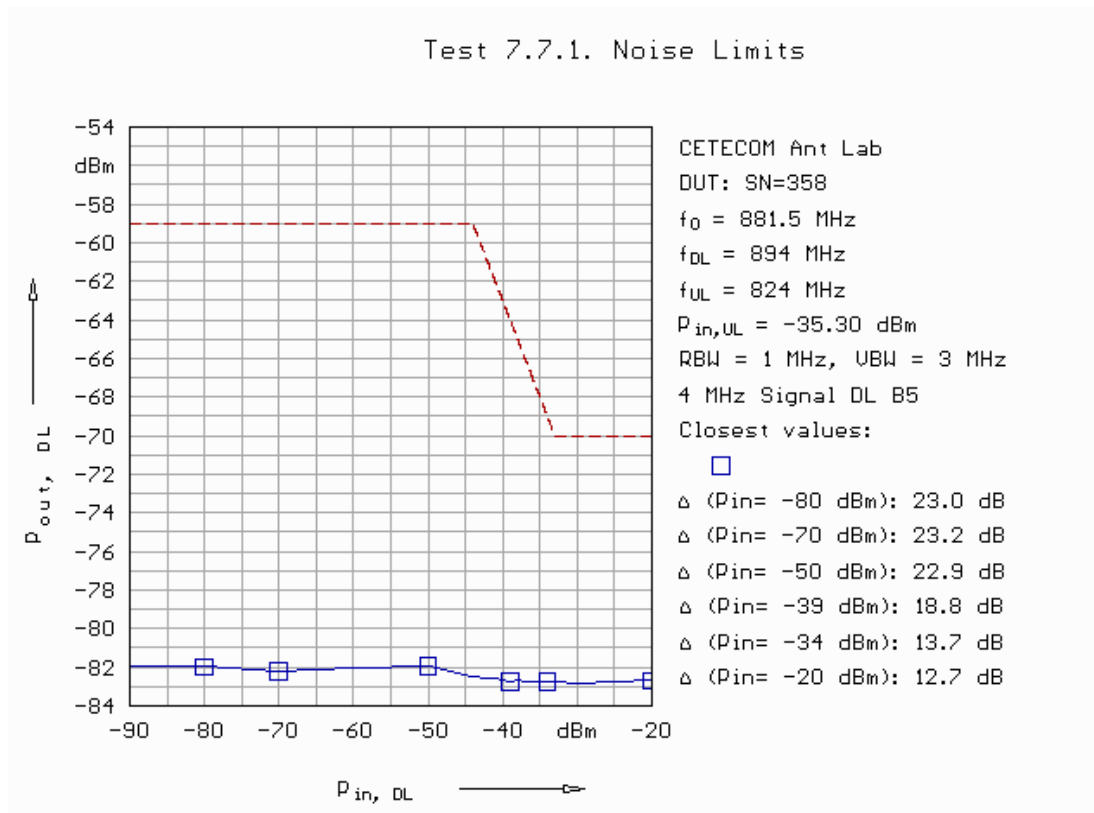

Fig. 186: Maximum transmitter noise power level in downlink in band 5.

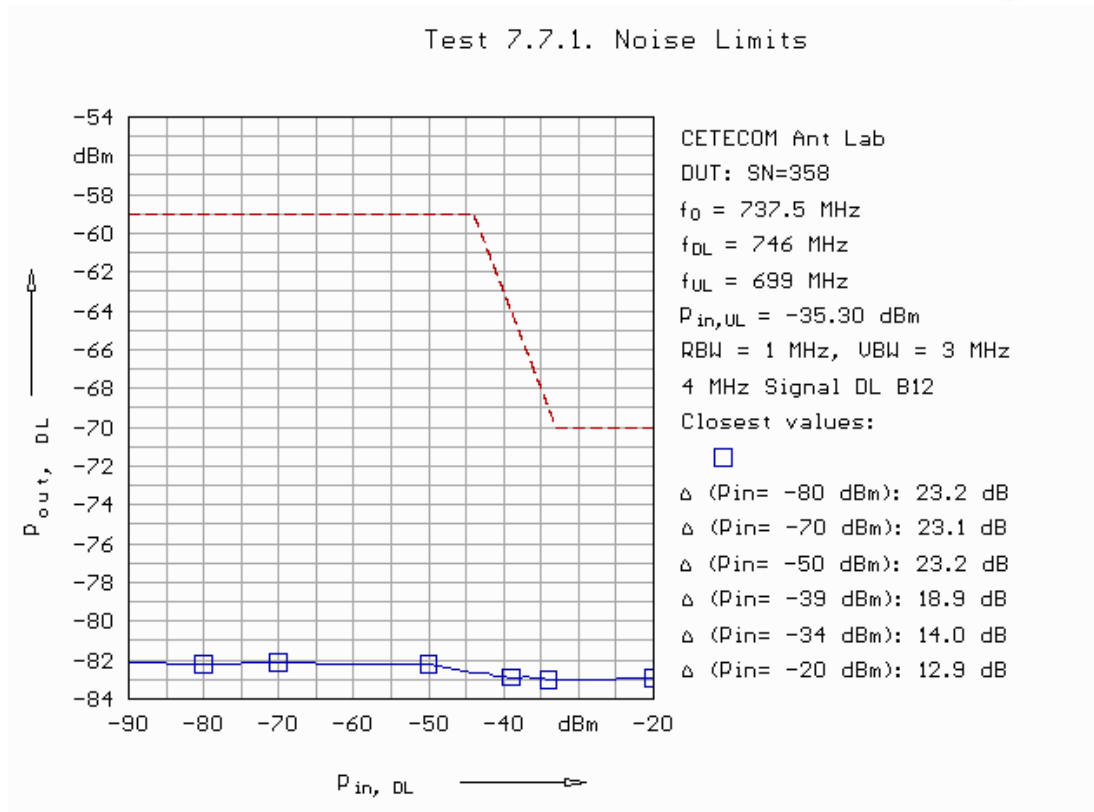

Fig. 187: Maximum transmitter noise power level in downlink in band 12.

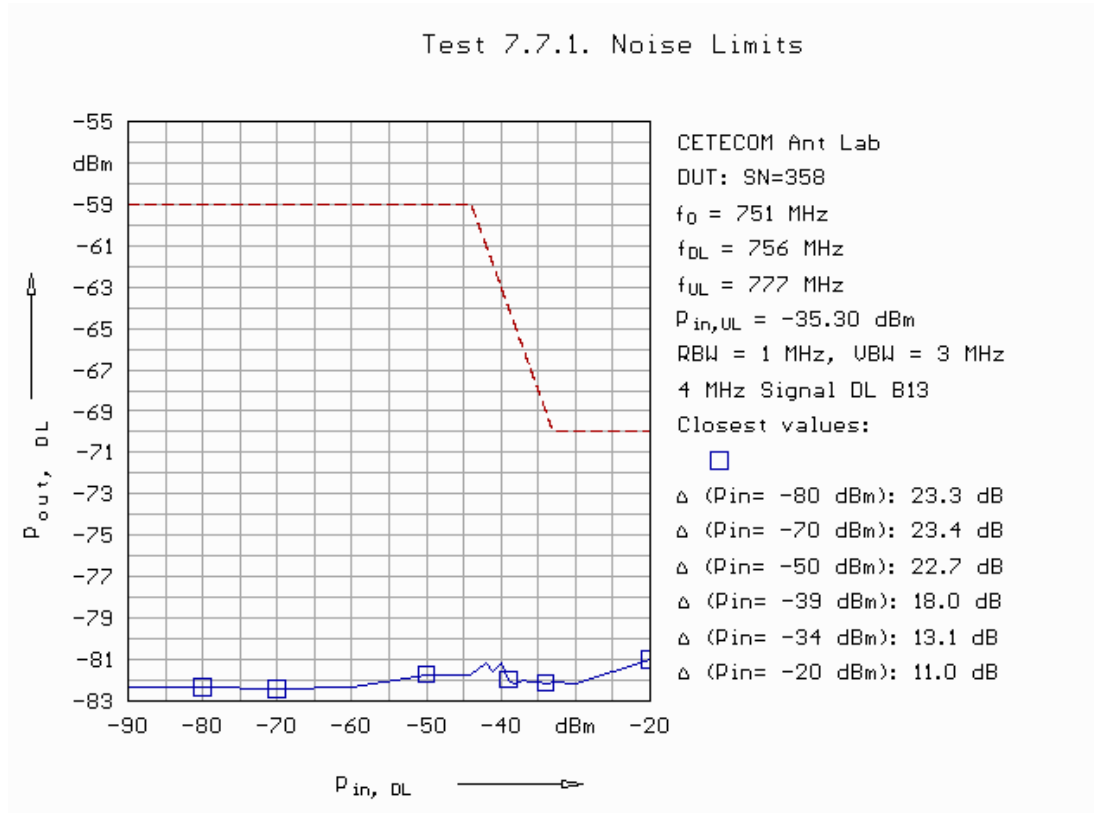

Fig. 188: Maximum transmitter noise power level in downlink in band 13.

5.7.2 Variable uplink noise timing

Below are summarized the measured results for Variable uplink Noise Timing. The activated cable routing for this test is shown in Fig. 157.

Band	direction	uplink noise decrease time	Limit	Result
2	up	0,86 s	$\leq 1s$	Pass
4	up	0,60 s	$\leq 1s$	Pass
5	up	0,80 s	$\leq 1s$	Pass
12	up	0,60 s	$\leq 1s$	Pass
13	up	0,44 s	$\leq 1s$	Pass

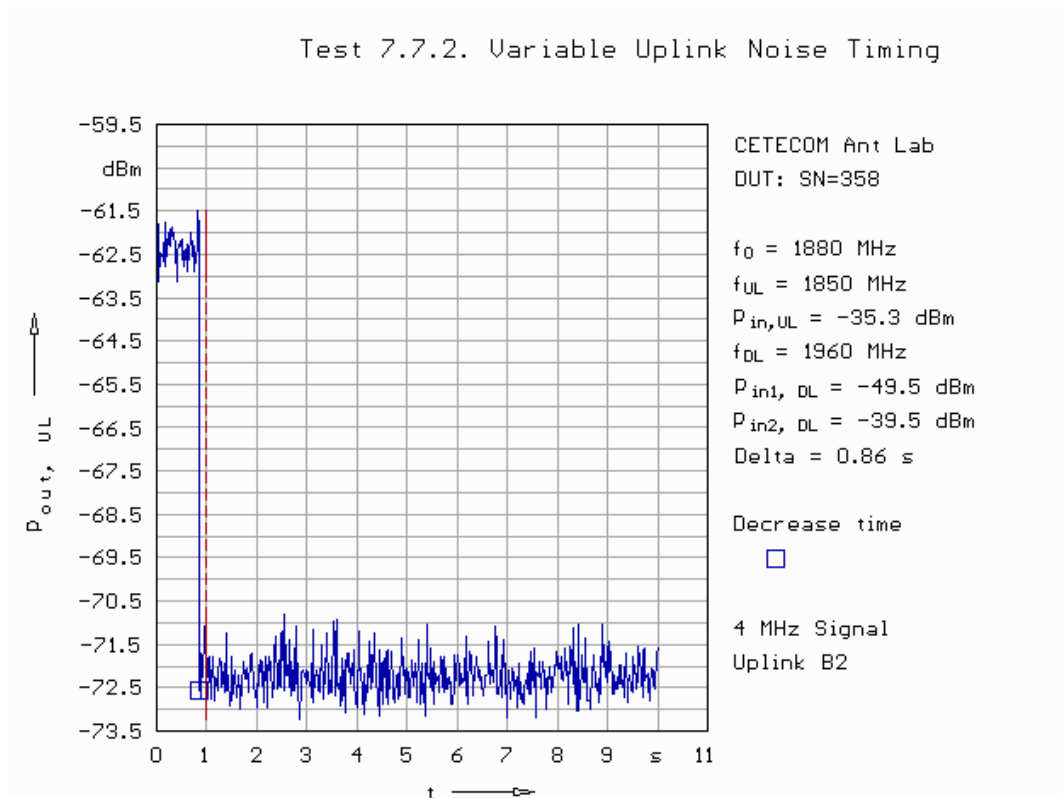

Fig. 189: Variable Uplink Noise Timing limits in band 2.

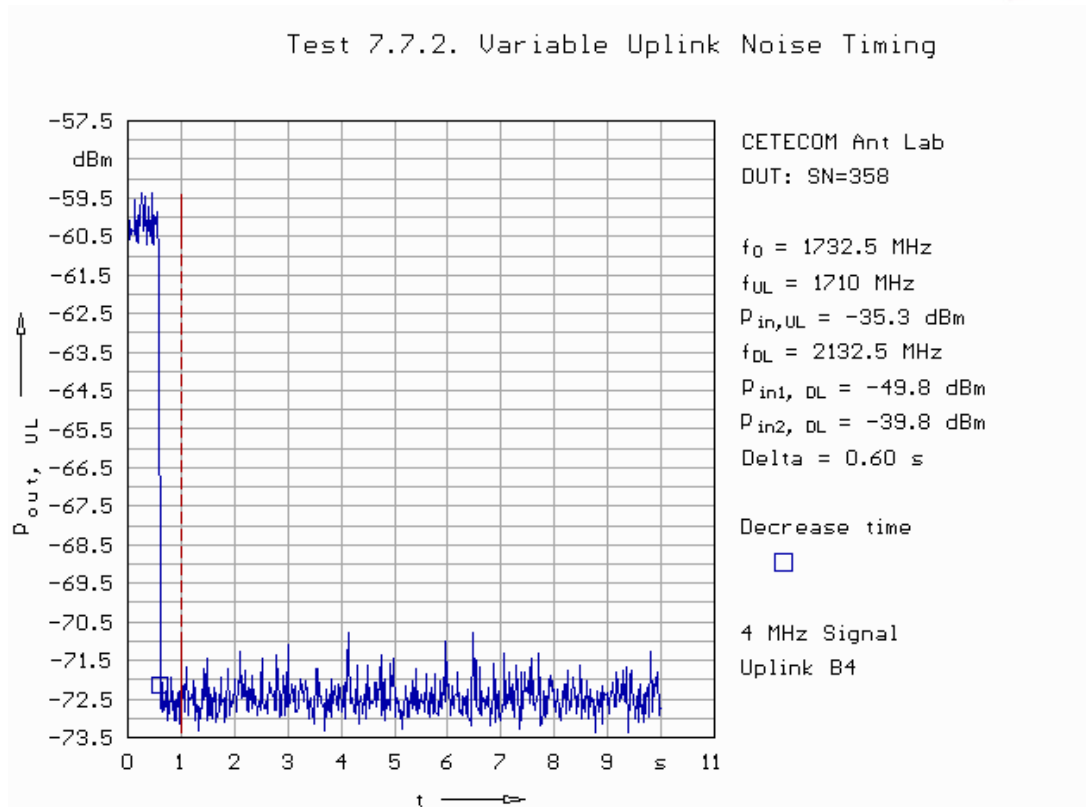

Fig. 190: Variable Uplink Noise Timing limits in band 4.

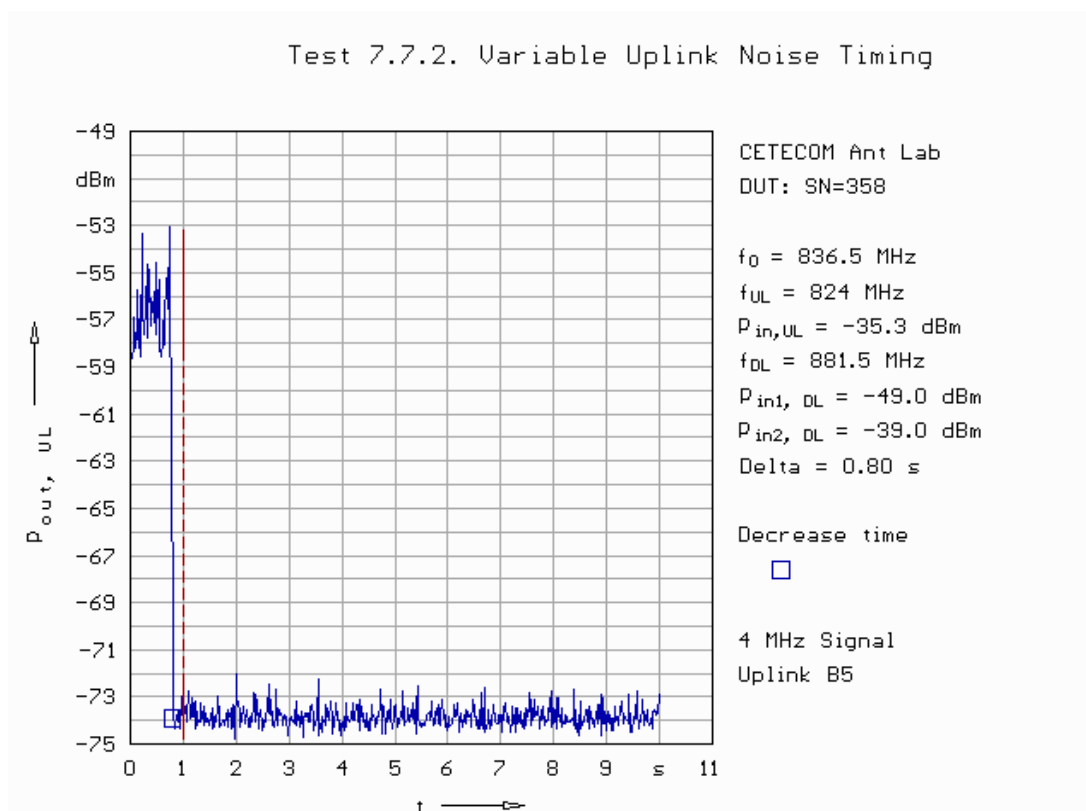

Fig. 191: Variable Uplink Noise Timing limits in band 5.

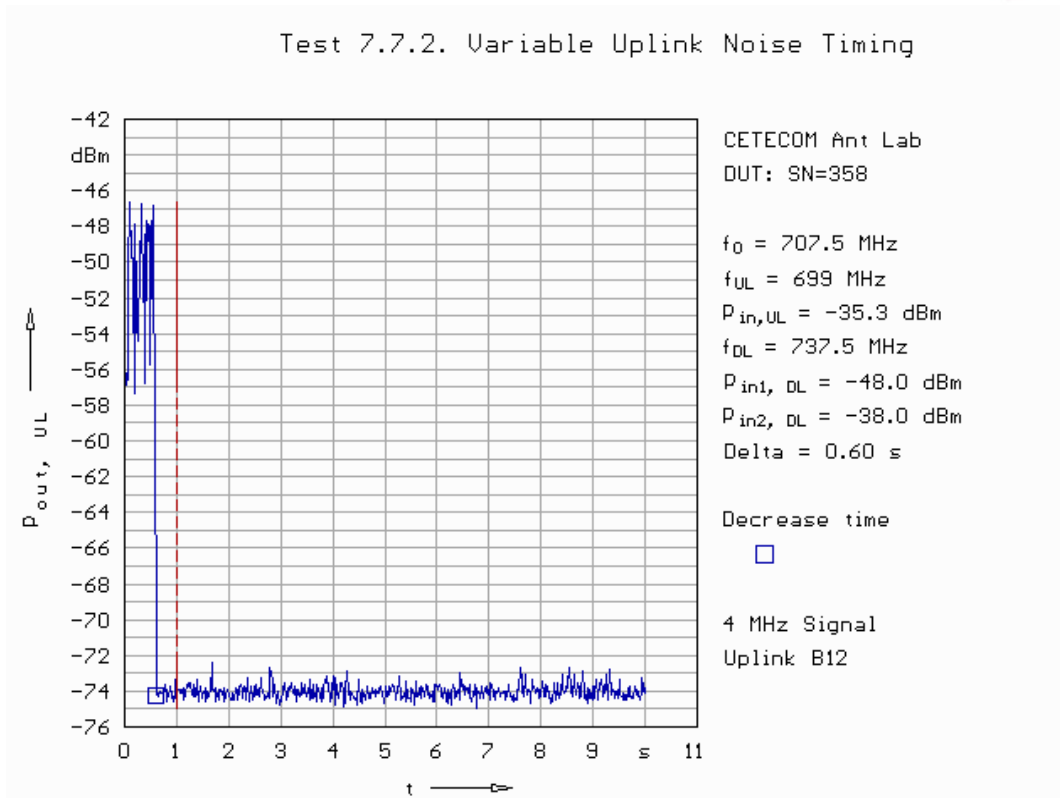

Fig. 192: Variable Uplink Noise Timing limits in band 12.

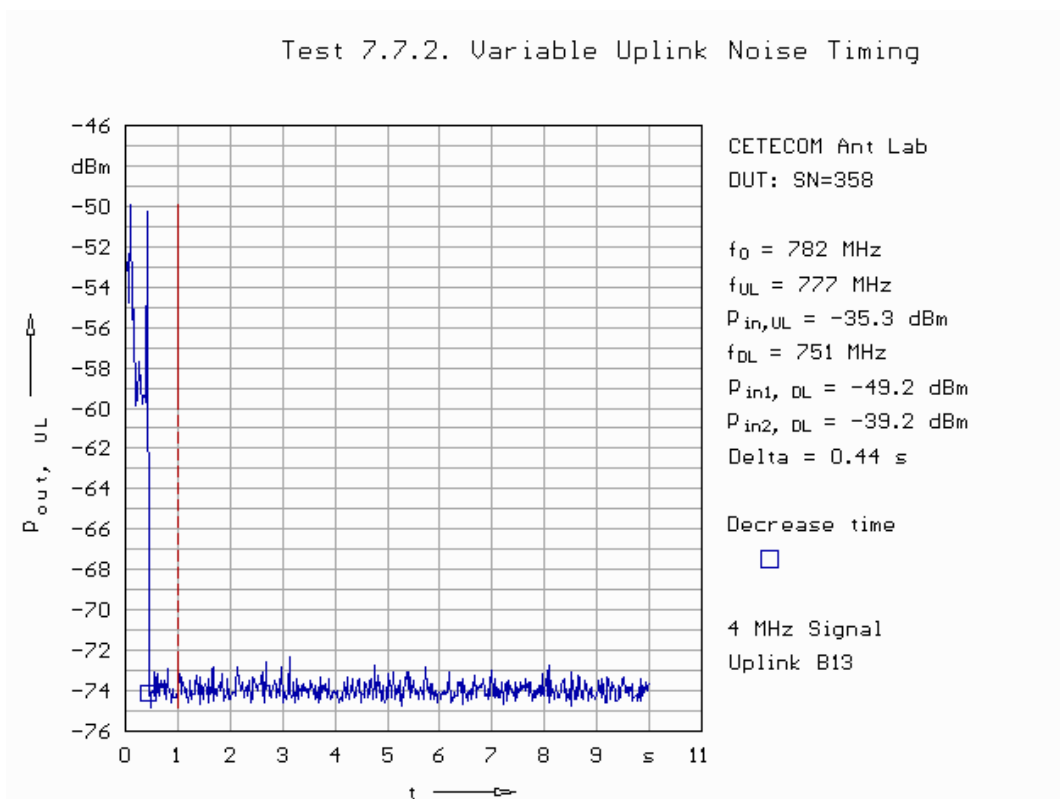

Fig. 193: Variable Uplink Noise Timing limits in band 13.

5.8. Uplink Inactivity

In order to test automatically the time the system need to enter an uplink inactivity state we did the following:

- 1.) Switch OFF booster
- 2.) Apply a CW signal at the server port
- 3.) After 15 seconds we switched ON the booster
- 4.) Immediately after that we switched the signal OFF.

The pictures below shows the DUT basically immediately switches OFF once the signal at the server port disappears.

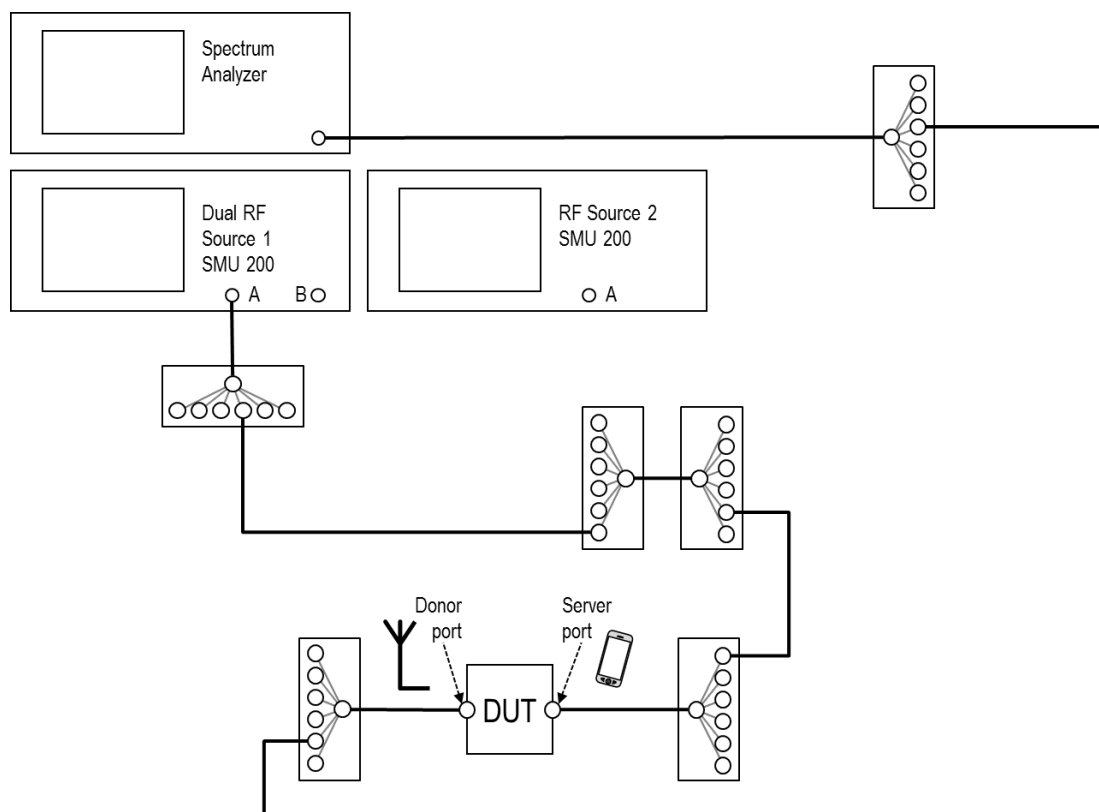

Fig. 194: Set up for the uplink inactivity tests.

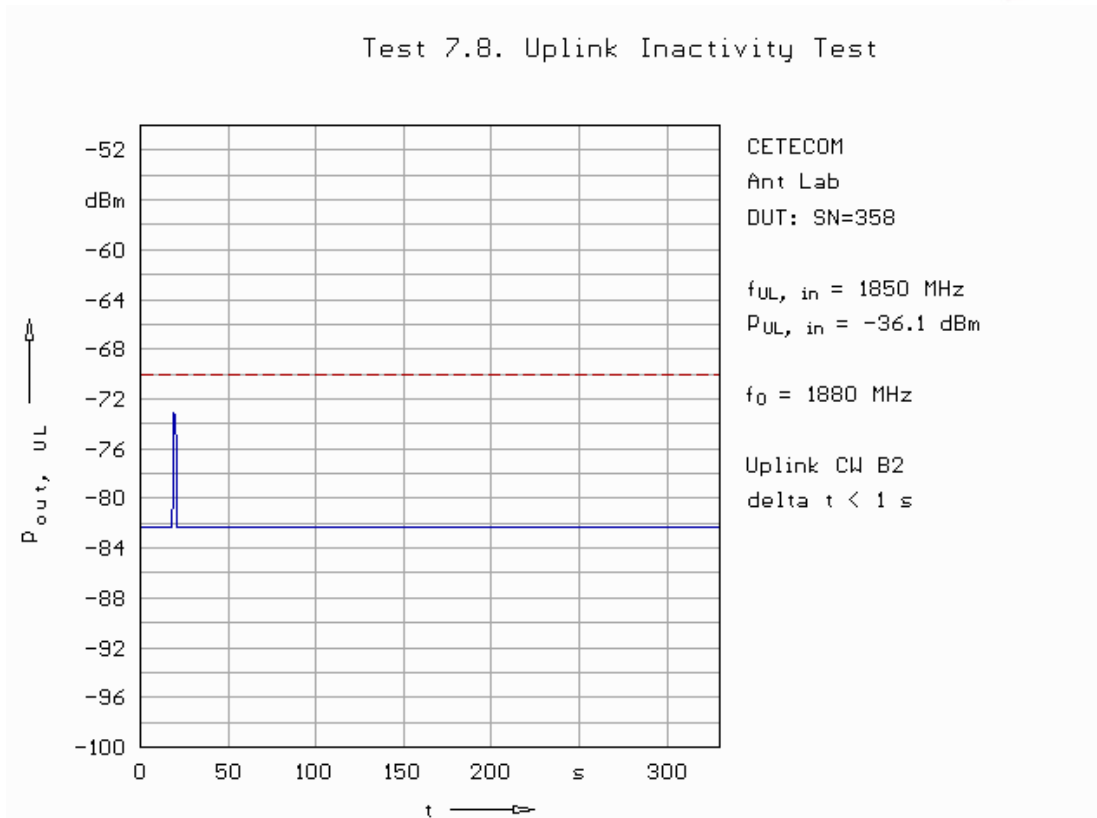

Fig. 195: Uplink inactivity test in band 2.

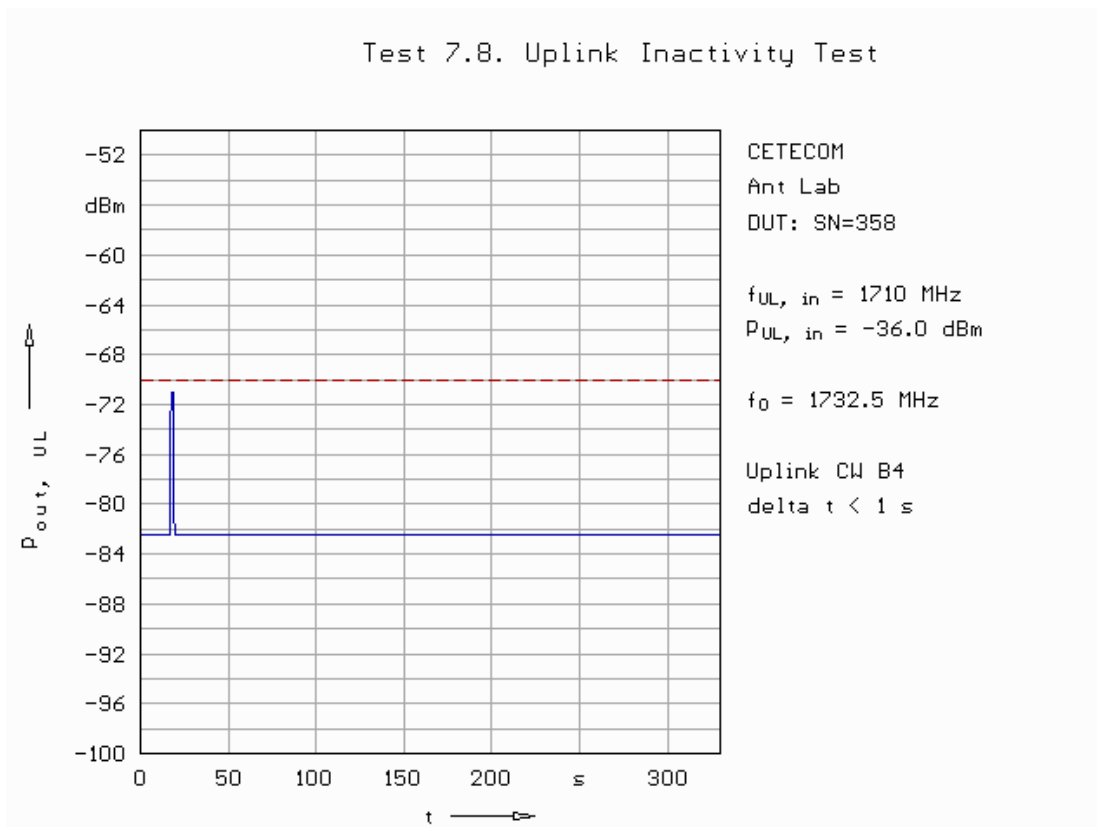

Fig. 196: Uplink inactivity test in band 4.

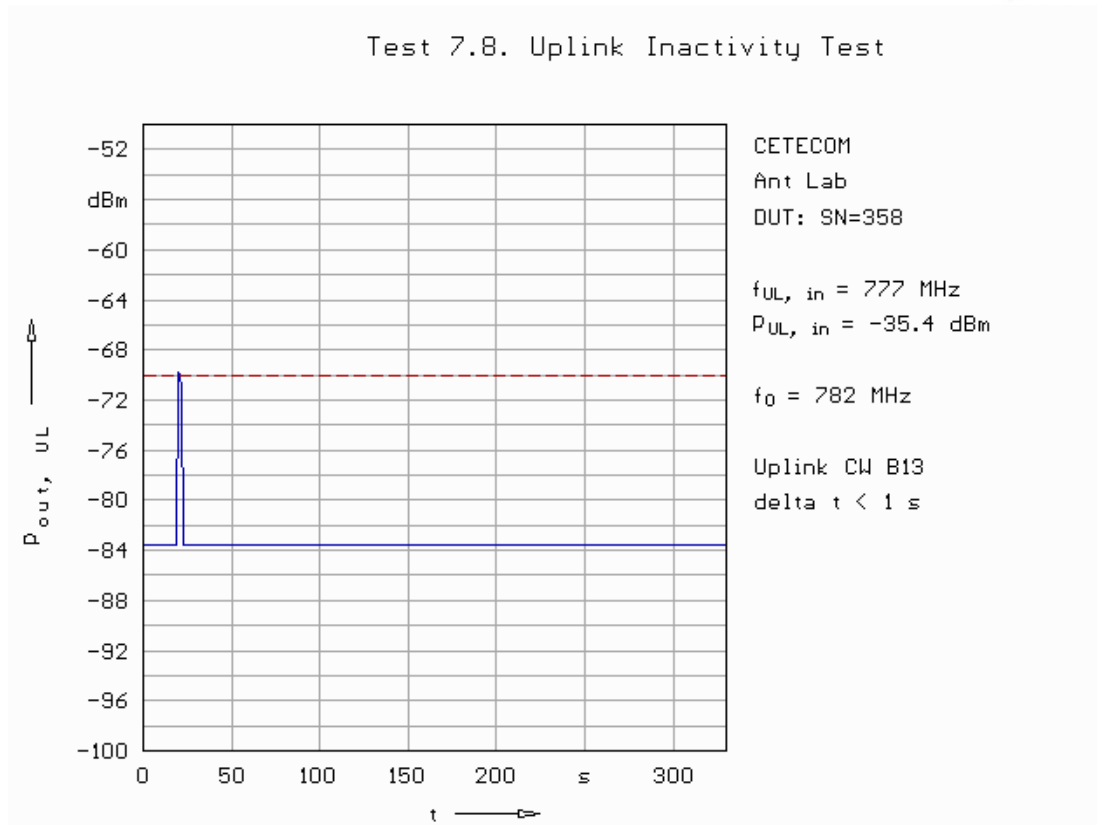

Fig. 197: Uplink inactivity test in band 5.

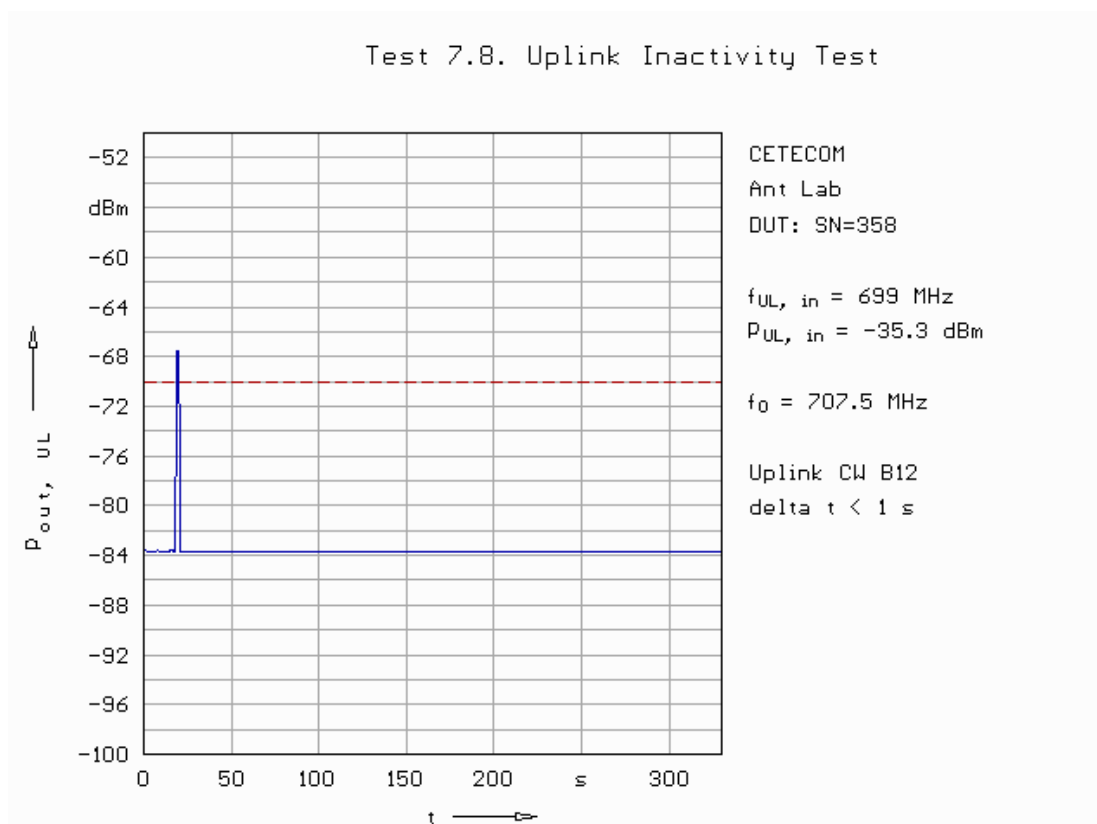

Fig. 198: Uplink inactivity test in band 12.

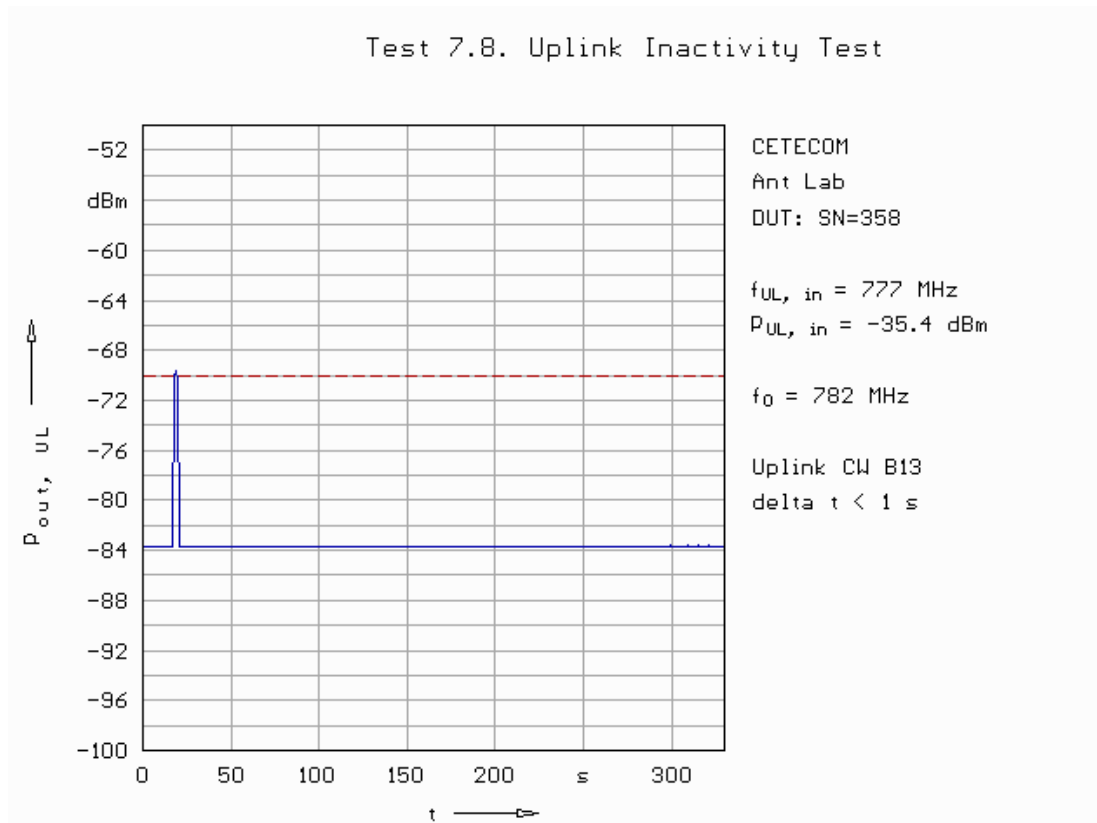

Fig. 199: Uplink inactivity test in band 13.

5.9. Variable Gain and Uplink Gain Timing

For measuring the variable gain and its dependency on RSSI signal level signal routings as shown in Fig. 200 and Fig. 201 are used. For the special booster under test always a signal at the server port is required to enable the uplink amplifier.

Within the variable gain data provided are measurement values for the gain values found with closest distance to the limit line. This distance is reported as “delta” in dB at the plots.

All data found met the limits for variable gain. All timing data found met the 1 s limit.

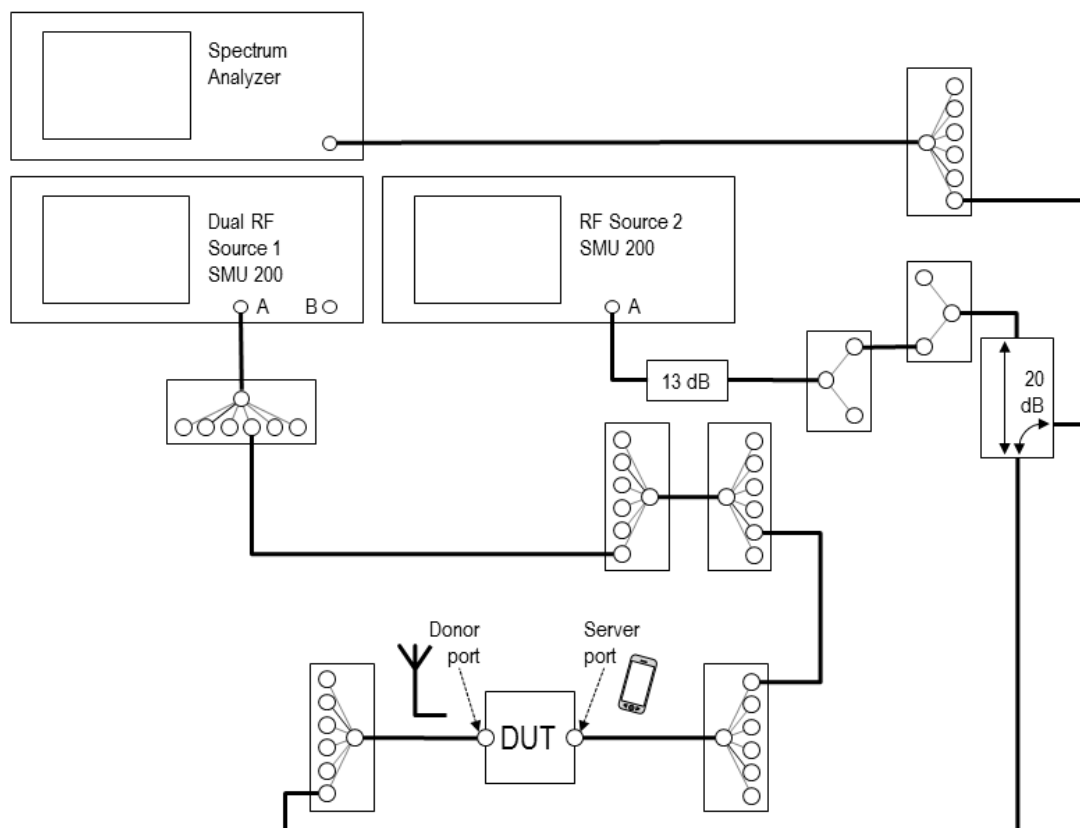

Fig. 200: Set up for the variable (RSSI dependent) gain measurements in uplink.

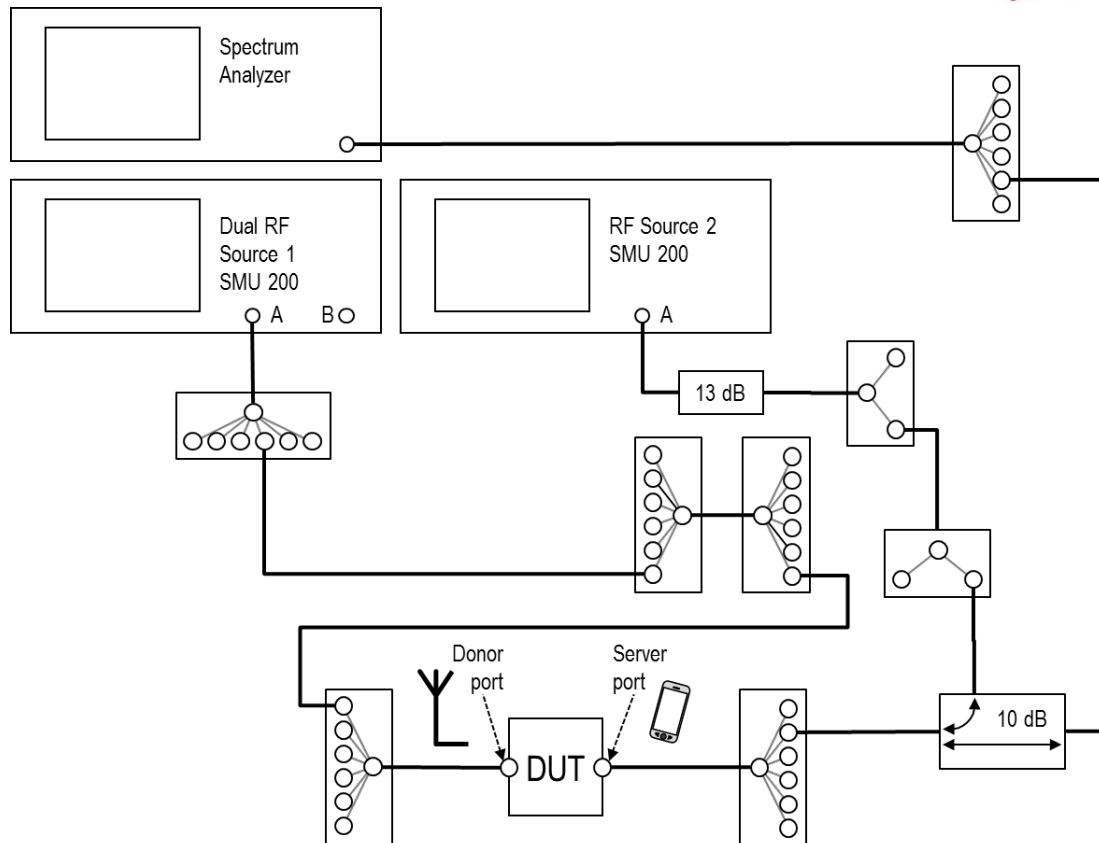

Fig. 201: Set up for the variable (RSSI dependent) gain measurements in downlink.

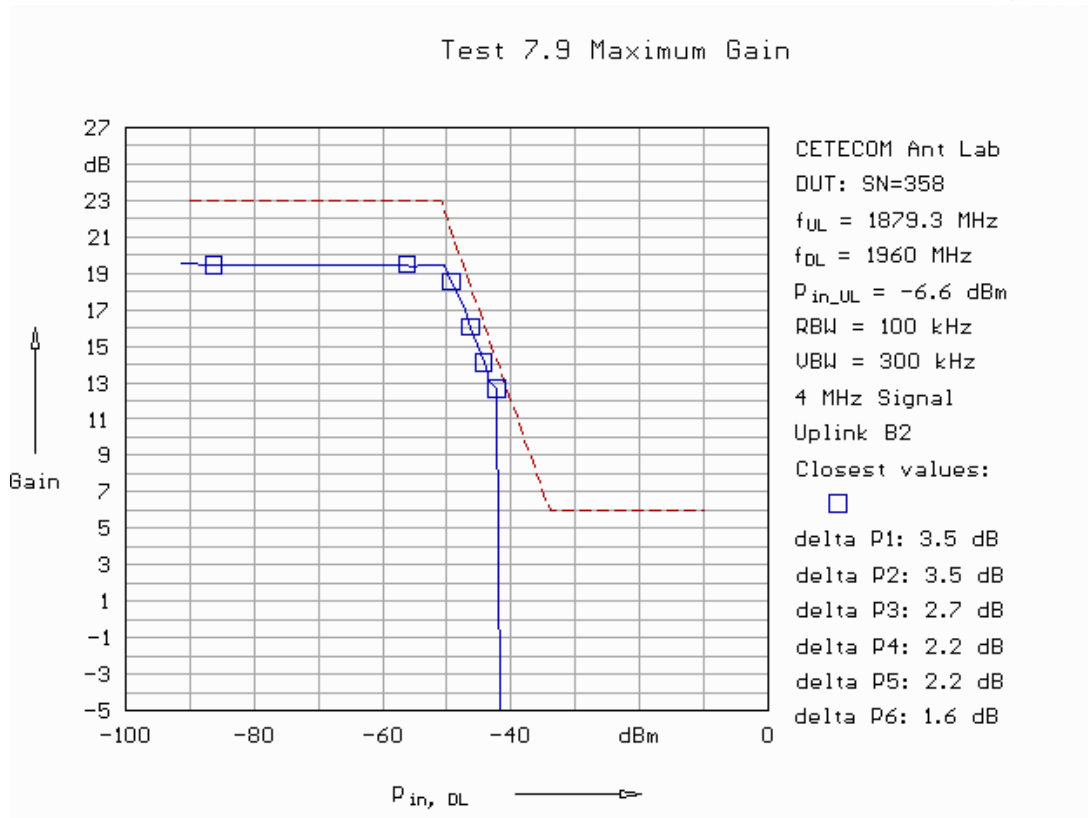

Fig. 202: Variable RSSI dependent uplink gain in band 2.

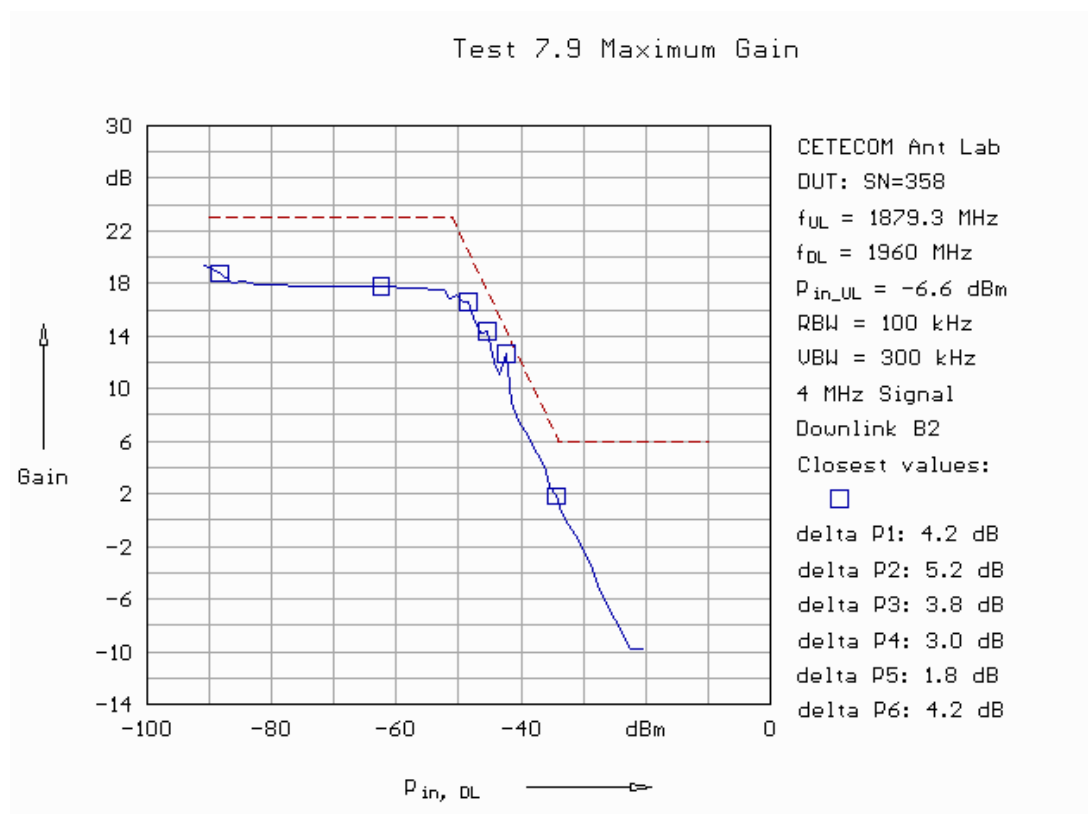

Fig. 203: Variable RSSI dependent downlink gain in band 2.

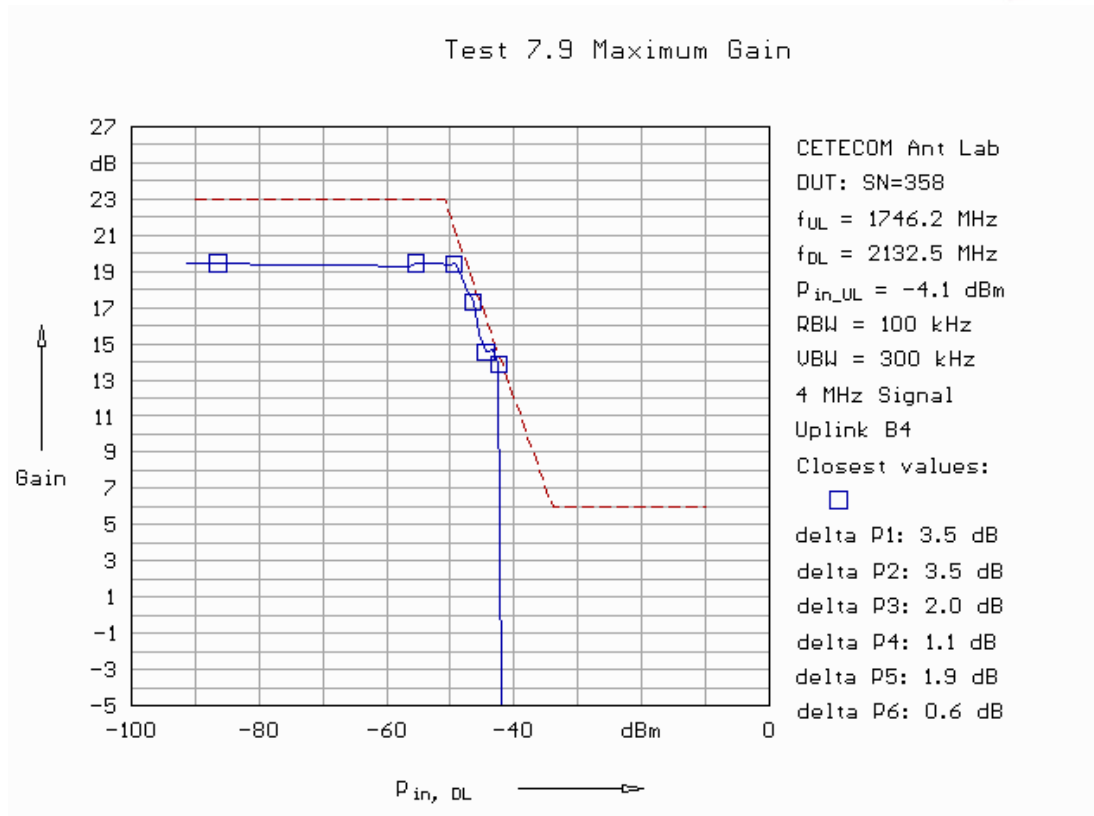

Fig. 204: Variable RSSI dependent uplink gain in band 4.

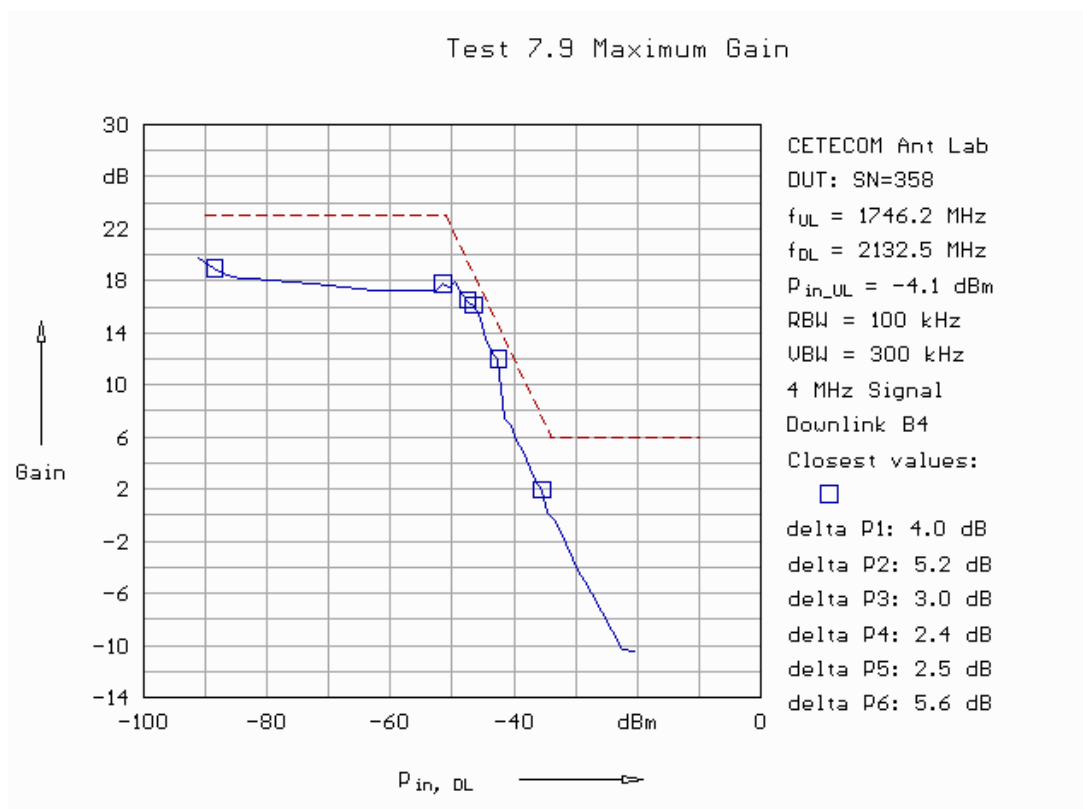

Fig. 205: Variable RSSI dependent downlink gain in band 4.

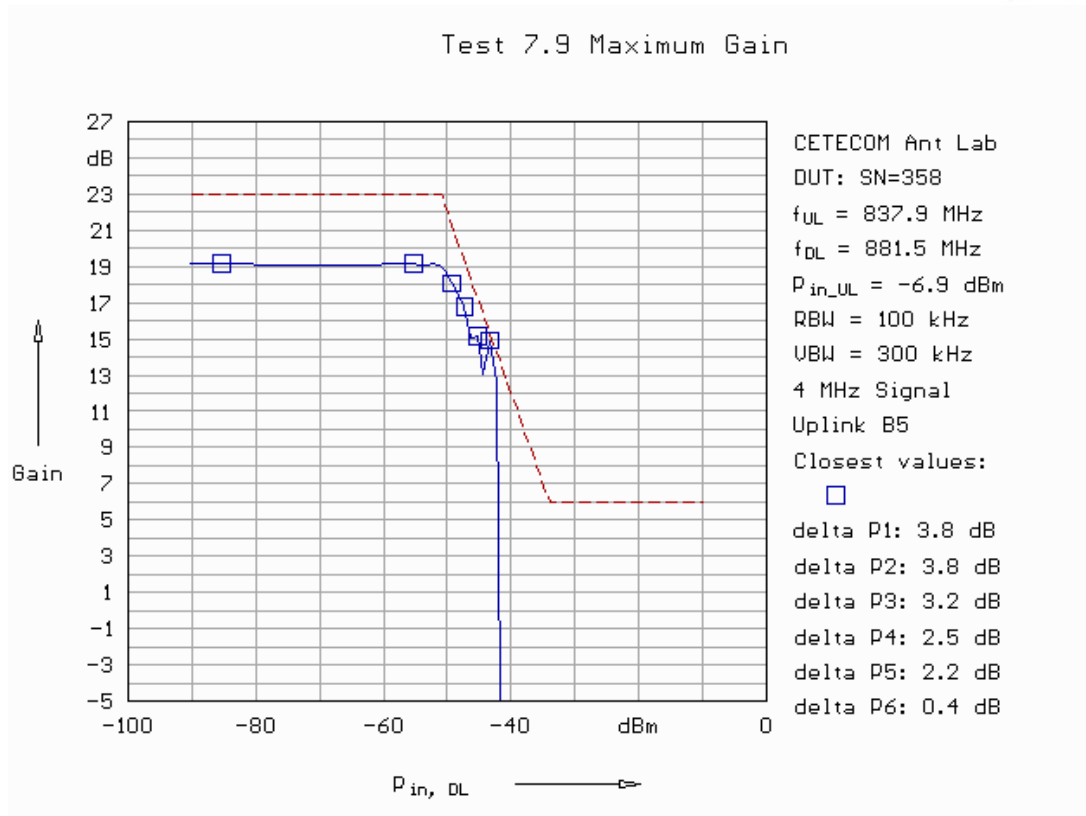

Fig. 206: Variable RSSI dependent uplink gain in band 5.

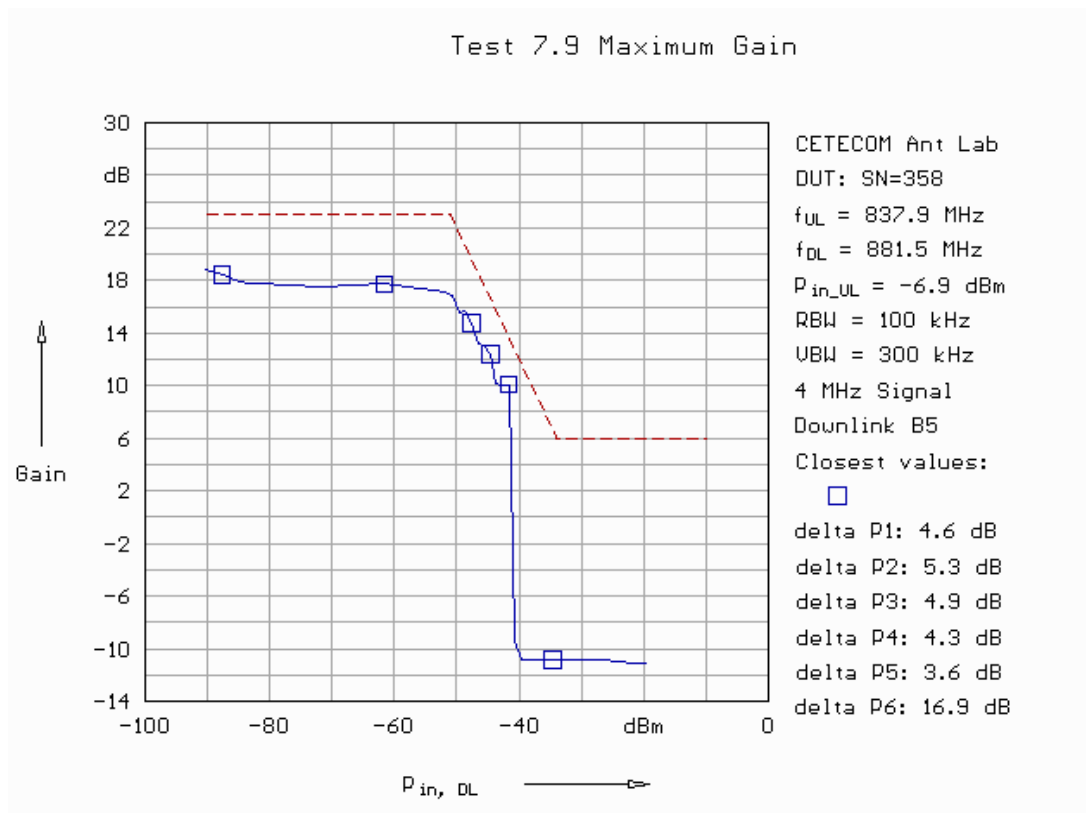

Fig. 207: Variable RSSI dependent downlink gain in band 5.

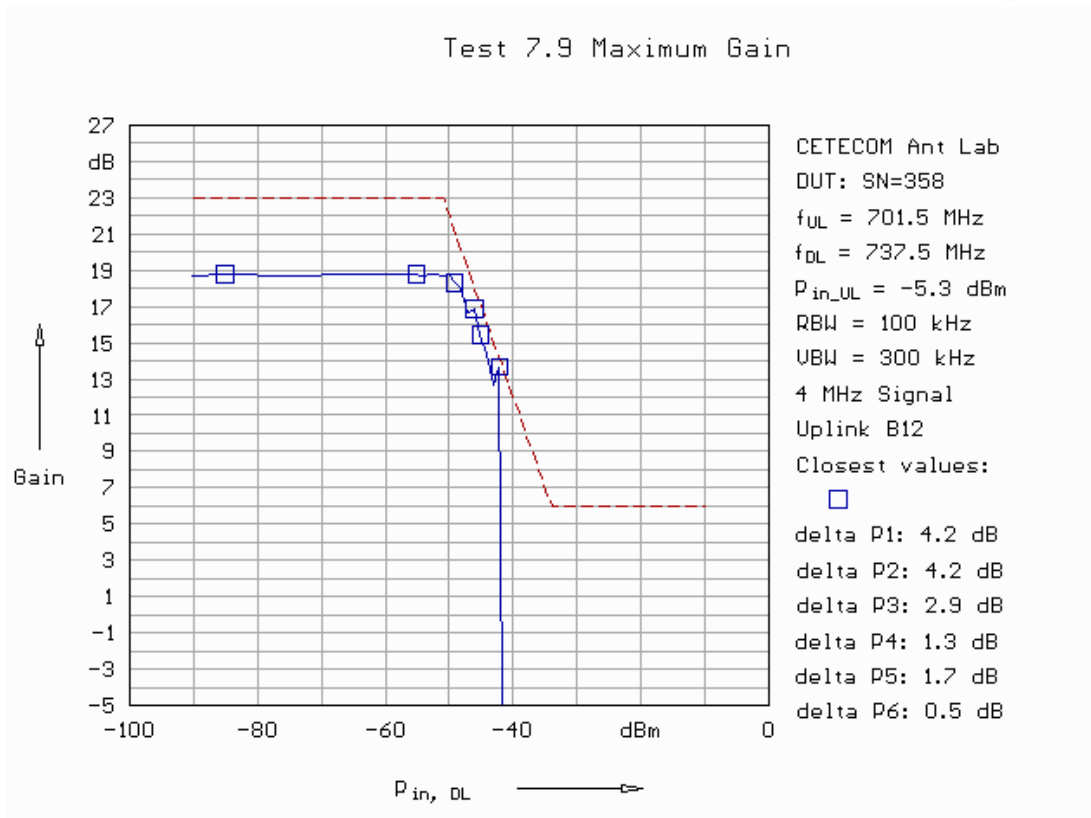

Fig. 208: Variable RSSI dependent uplink gain in band 12.

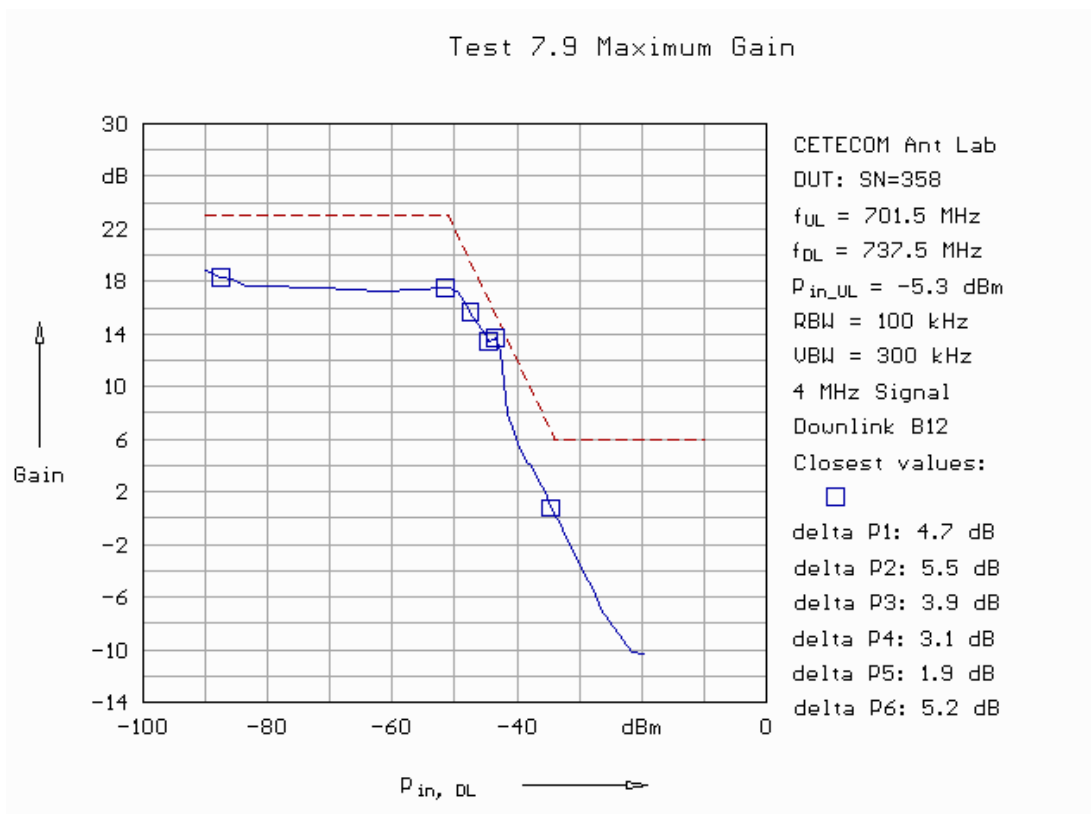

Fig. 209: Variable RSSI dependent downlink gain in band 12.

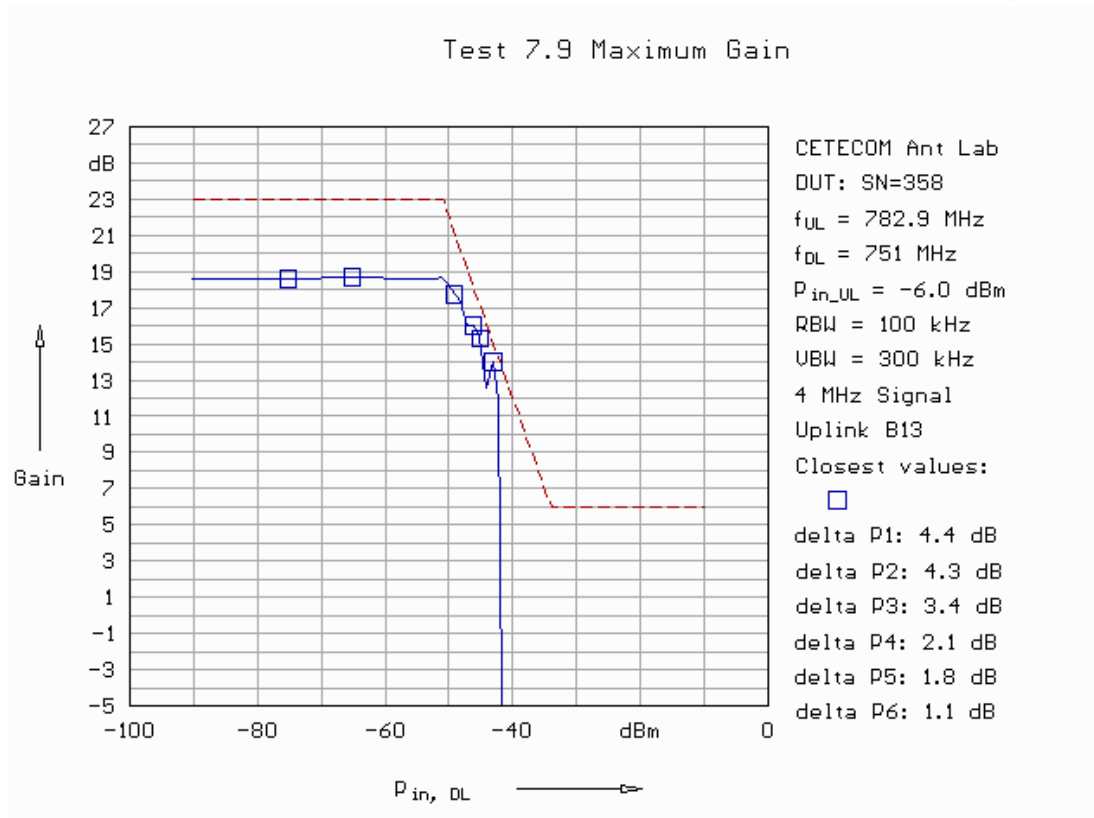

Fig. 210: Variable RSSI dependent uplink gain in band 13.

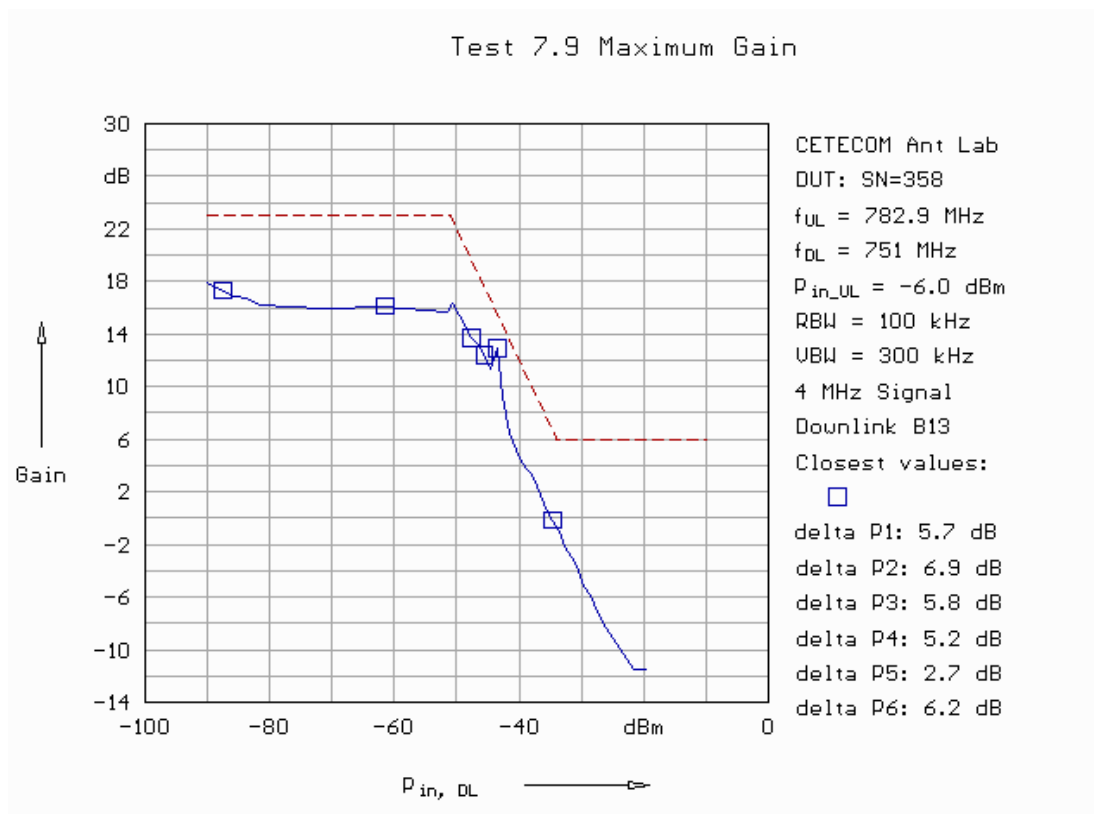

Fig. 211: Variable RSSI dependent downlink gain in band 13.

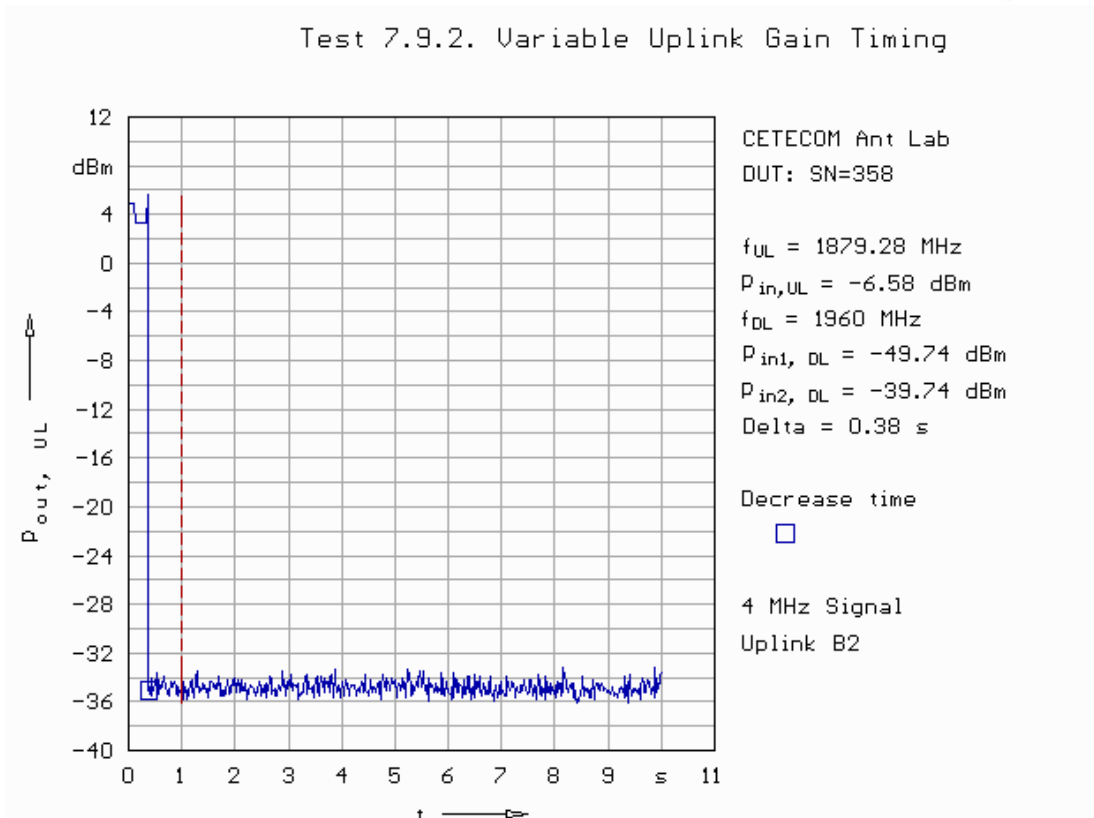

Fig. 212: Variable uplink gain timing in band 02.

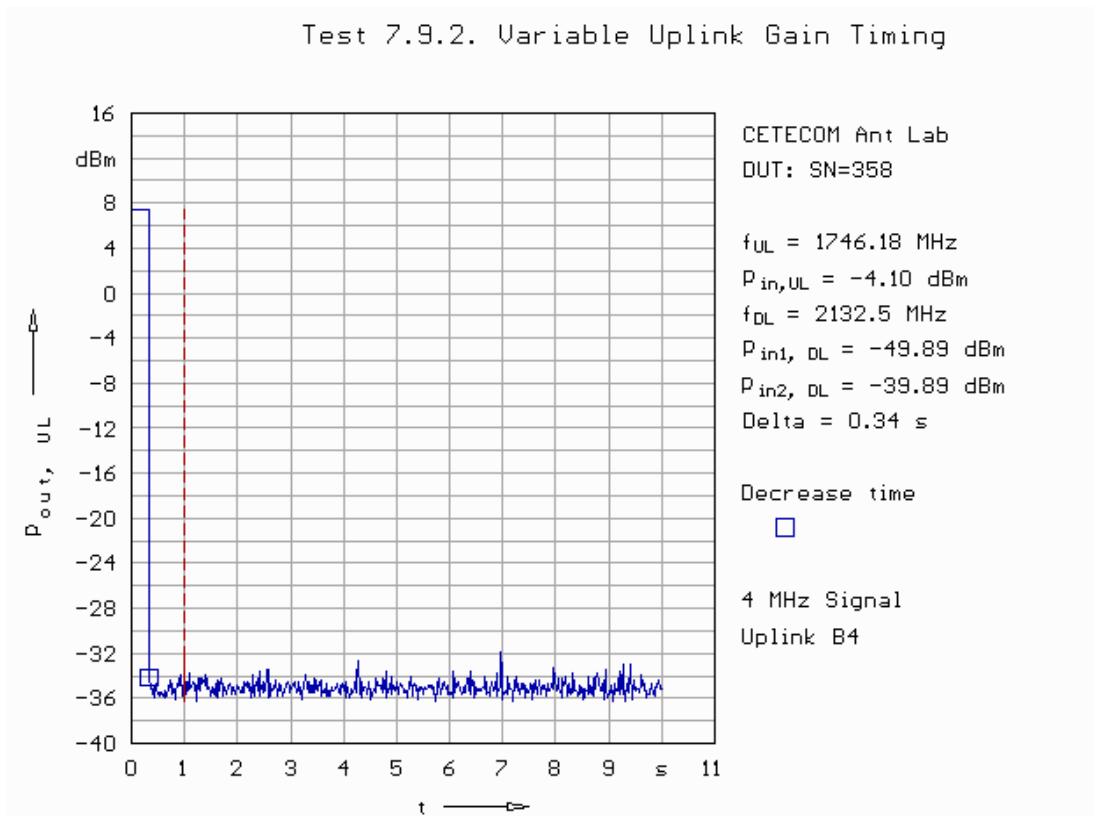

Fig. 213: Variable uplink gain timing in band 04.

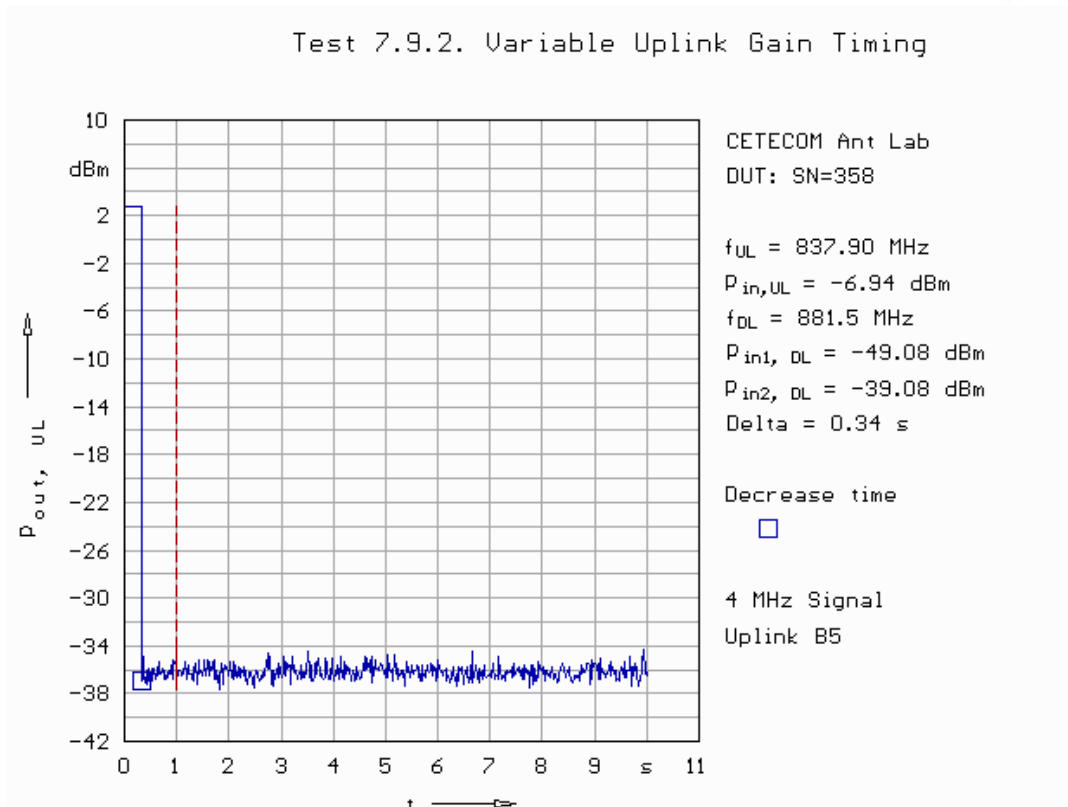

Fig. 214: Variable uplink gain timing in band 05.

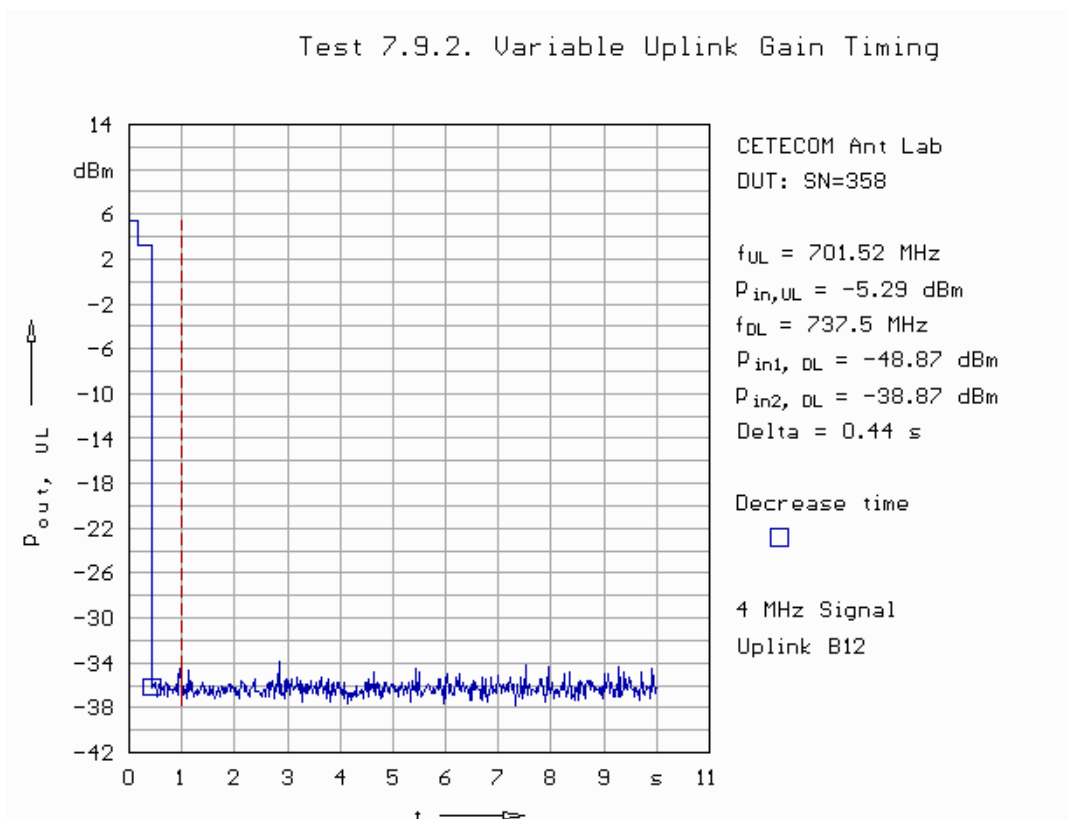

Fig. 215: Variable uplink gain timing in band 12.

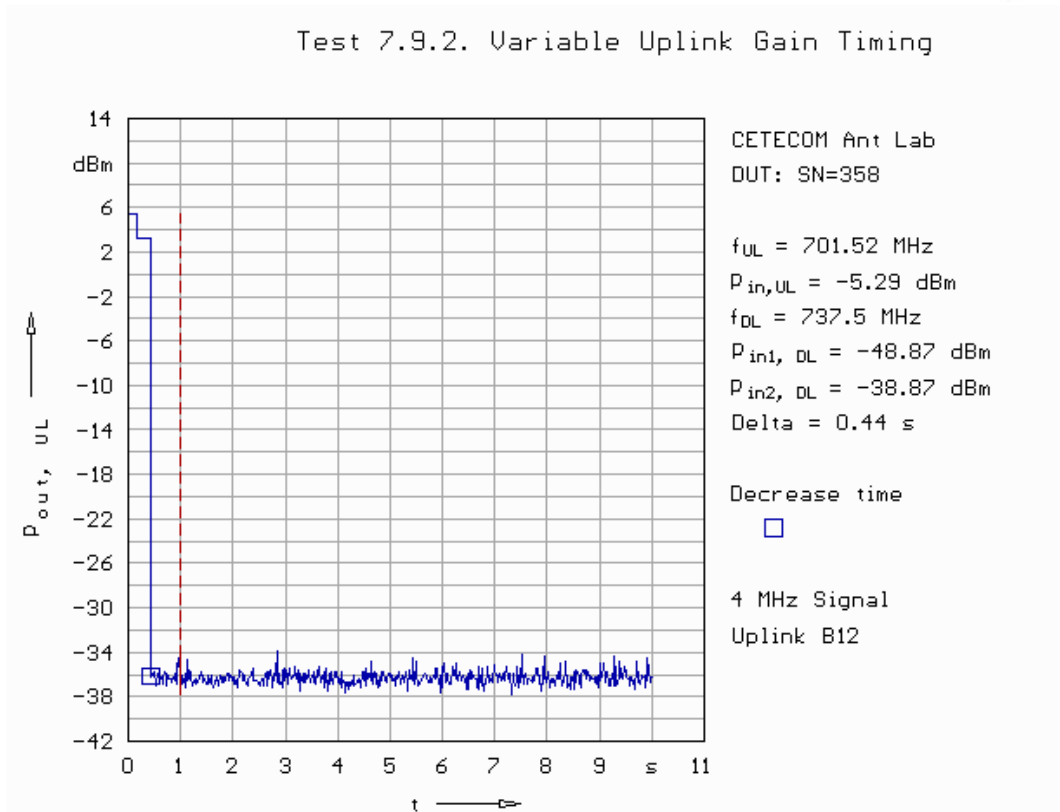

Fig. 216: Variable uplink gain timing in band 13.

5.10. Occupied Bandwidth

This measurement is required to compare the output signal relative to the input signal according to § 2.1049. In fact we found no substantial spectral growth.

The activated cable routing used is shown in Fig. 217 and Fig. 218 for up- and downlink, respectively. For showing the signal source signal the DUT was replaced by an RF through.

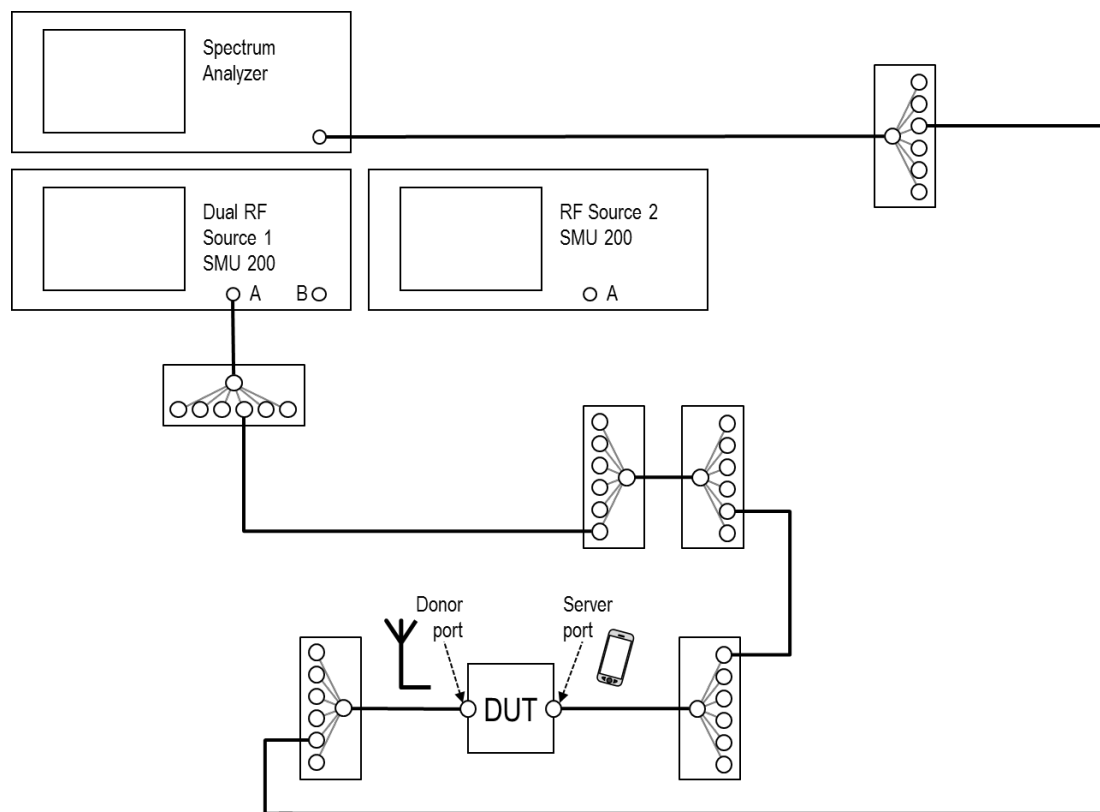

Fig. 217: Set up for the occupied bandwidth test in uplink.

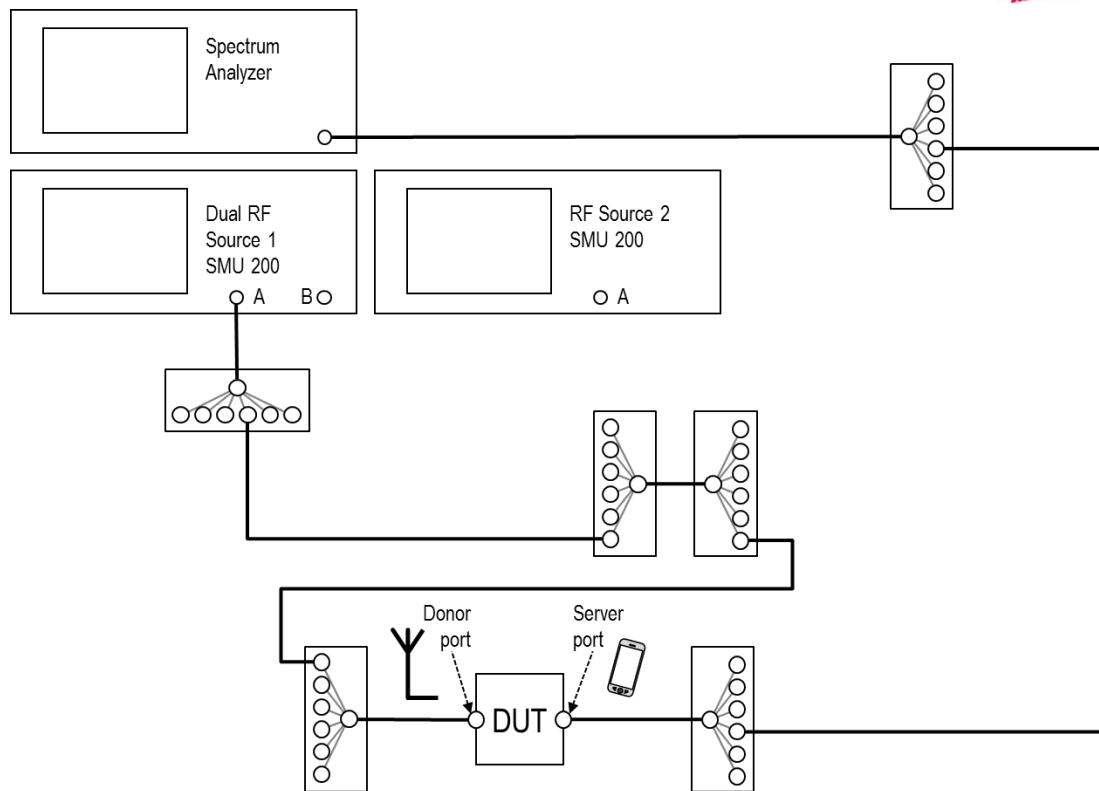
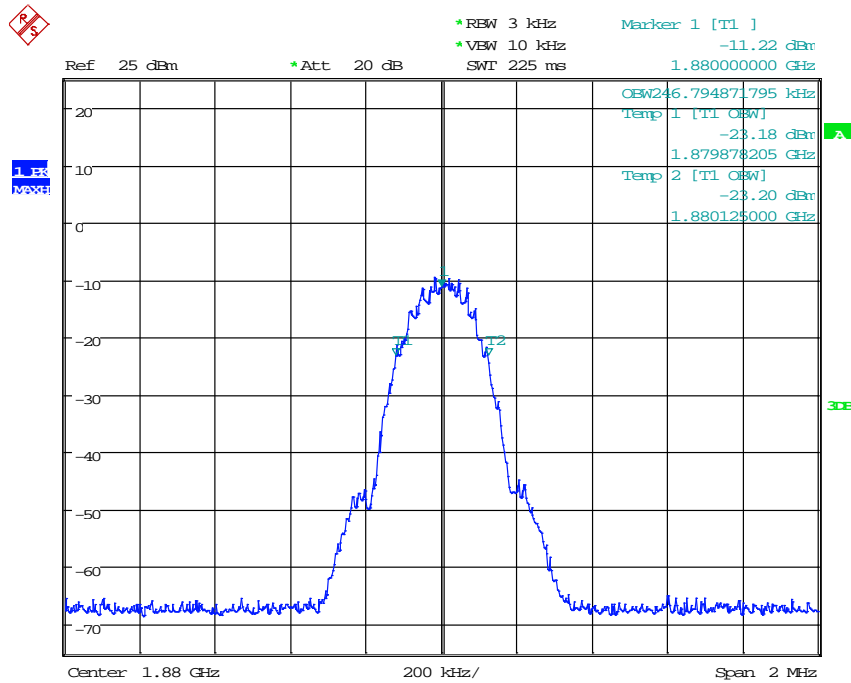
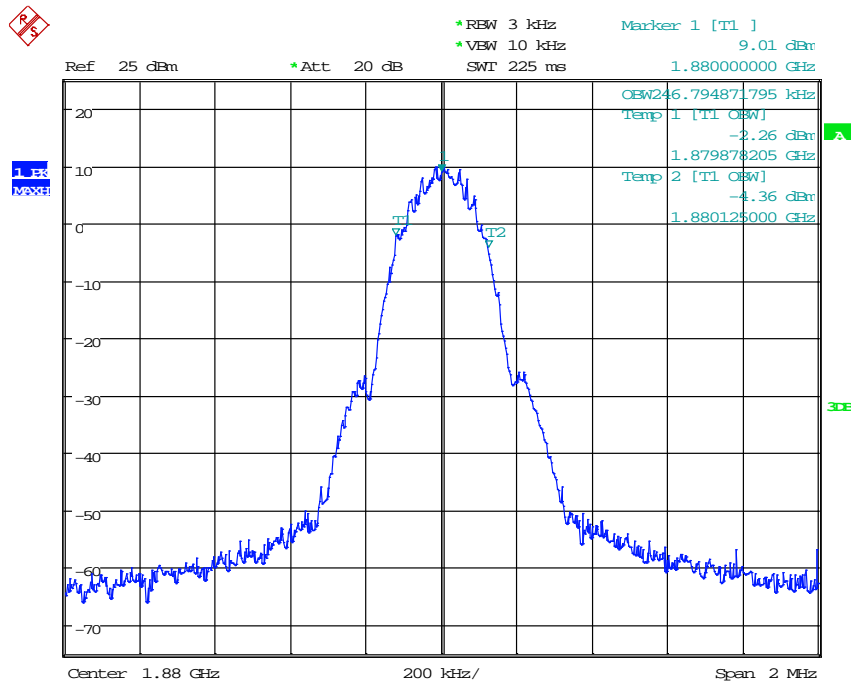

Fig. 218: Set up for occupied bandwidth test in downlink.



Date: 2.FEB.2016 12:50:36

Fig. 219: Occupied bandwidth for GSM signal when using a through in band 2 uplink.



Date: 29.JAN.2016 19:30:55

Fig. 220: Occupied bandwidth for GSM signal in band 2 uplink.

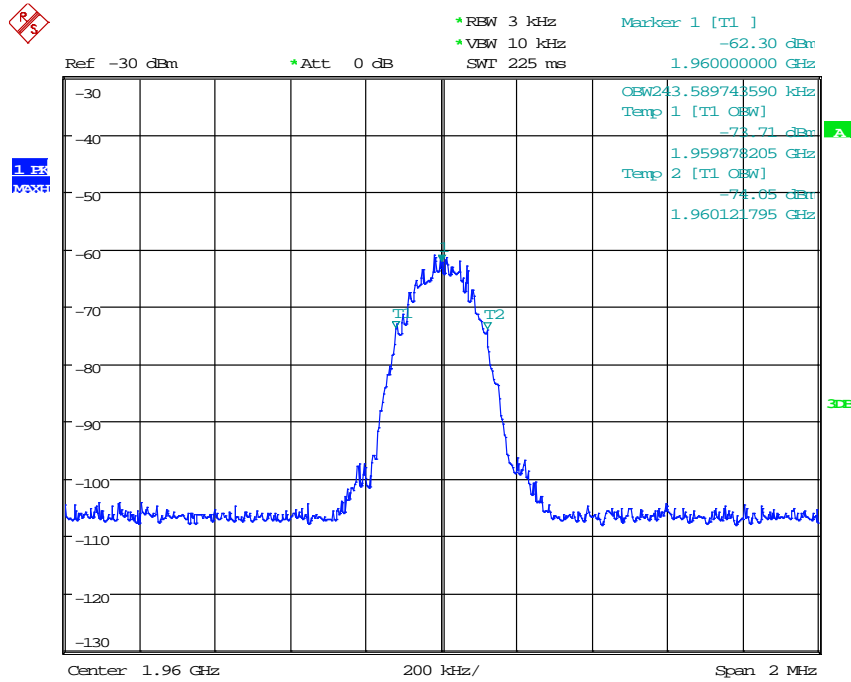

Date: 2.FEB.2016 12:51:52

Fig. 221: Occupied bandwidth for GSM signal when using a through in band 2 downlink.

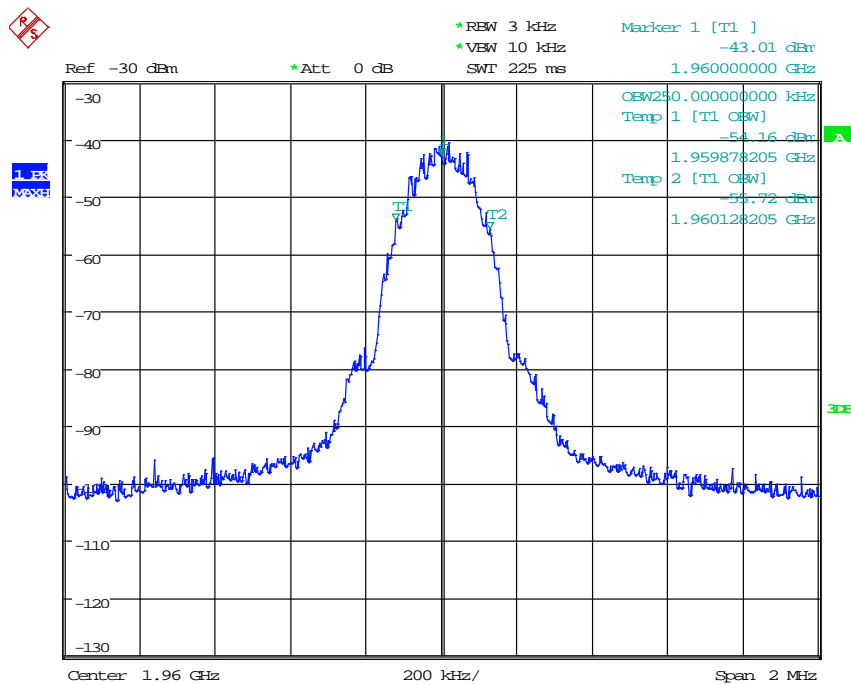

Date: 29.JAN.2016 19:39:16

Fig. 222: Occupied bandwidth for GSM signal in band 2 downlink.

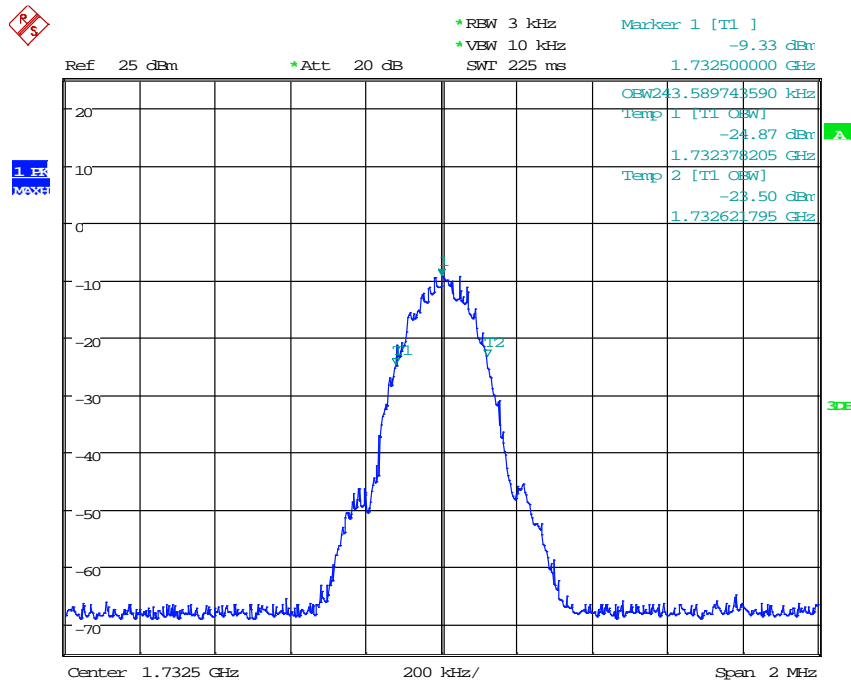

Date: 2.FEB.2016 12:53:18

Fig. 223: Occupied bandwidth for GSM signal when using a through in band 4 uplink.

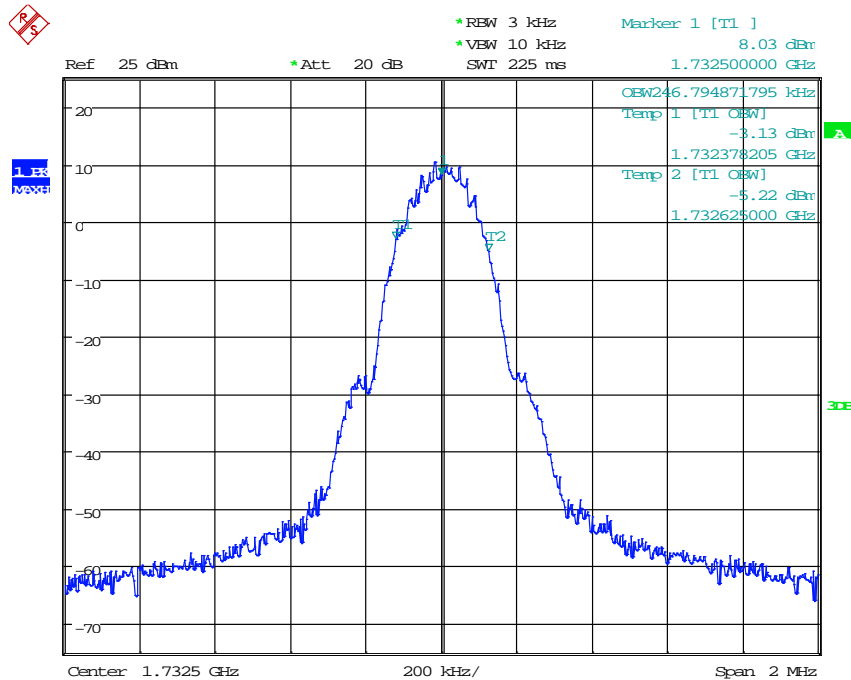

Date: 29.JAN.2016 19:47:50

Fig. 224: Occupied bandwidth for GSM signal in band 4 uplink.

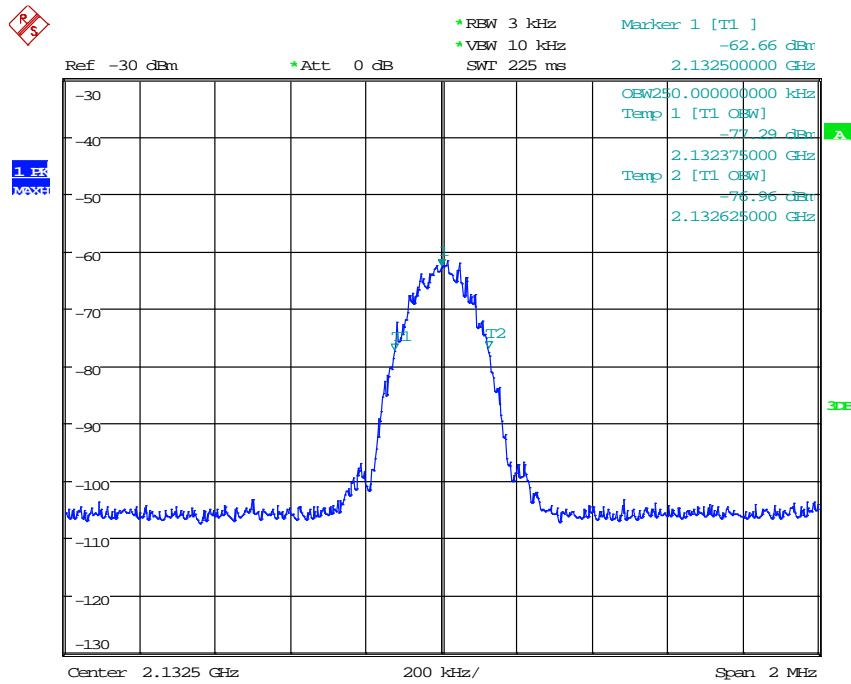

Date: 2.FEB.2016 12:54:54

Fig. 225: Occupied bandwidth for GSM signal when using a through in band 4 downlink.

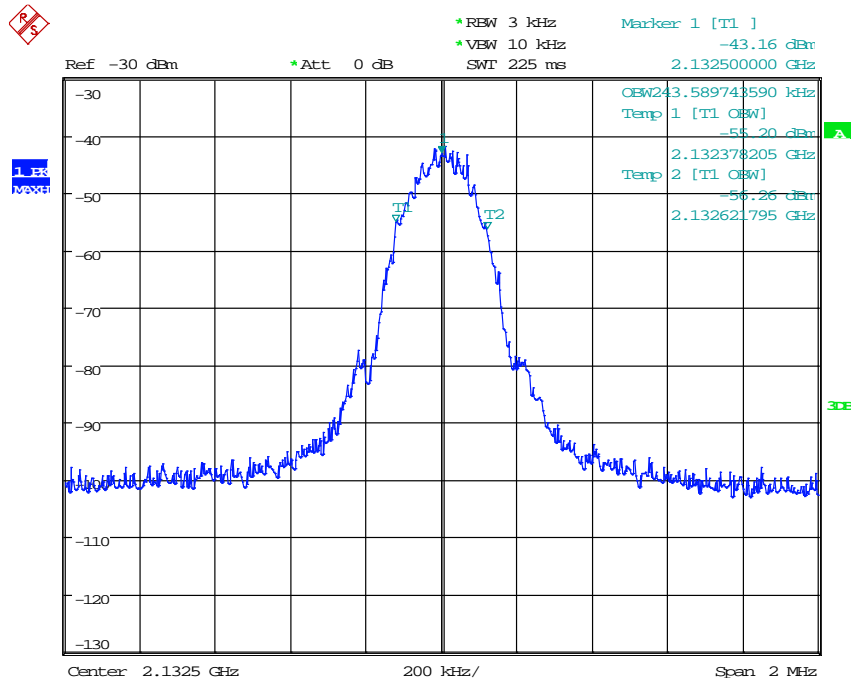

Date: 29.JAN.2016 19:50:37

Fig. 226: Occupied bandwidth for GSM signal in band 4 downlink.

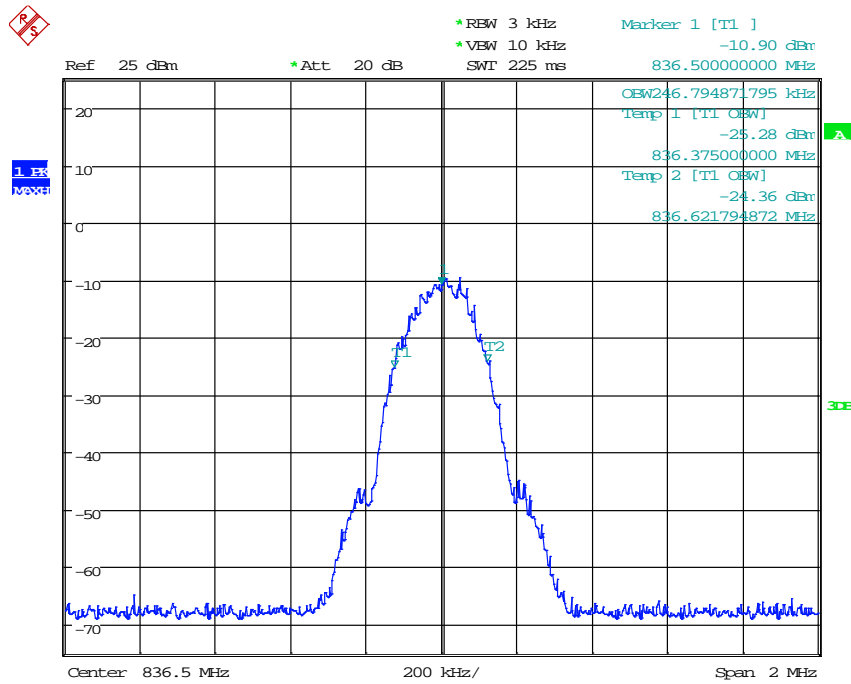

Date: 2.FEB.2016 12:56:24

Fig. 227: Occupied bandwidth for GSM signal when using a through in band 5 uplink.

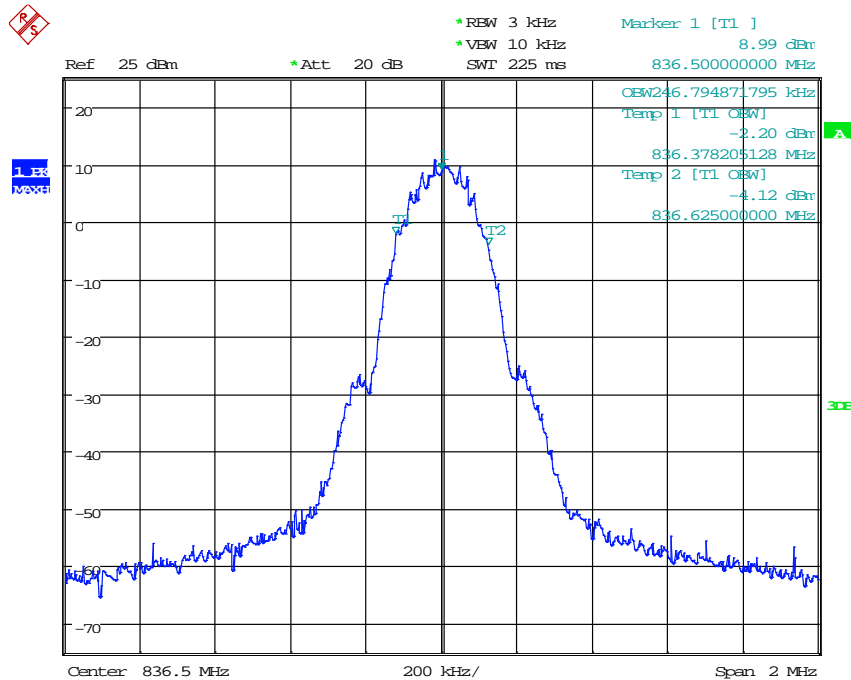

Date: 29.JAN.2016 20:09:36

Fig. 228: Occupied bandwidth for GSM signal in band 5 uplink.

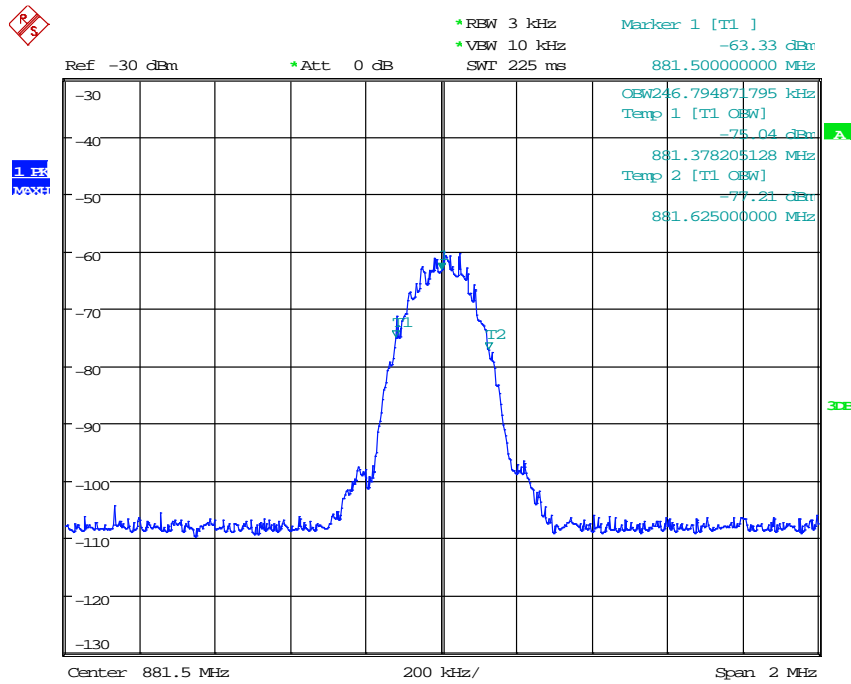

Date: 2.FEB.2016 12:58:34

Fig. 229: Occupied bandwidth for GSM signal when using a through in band 5 downlink.

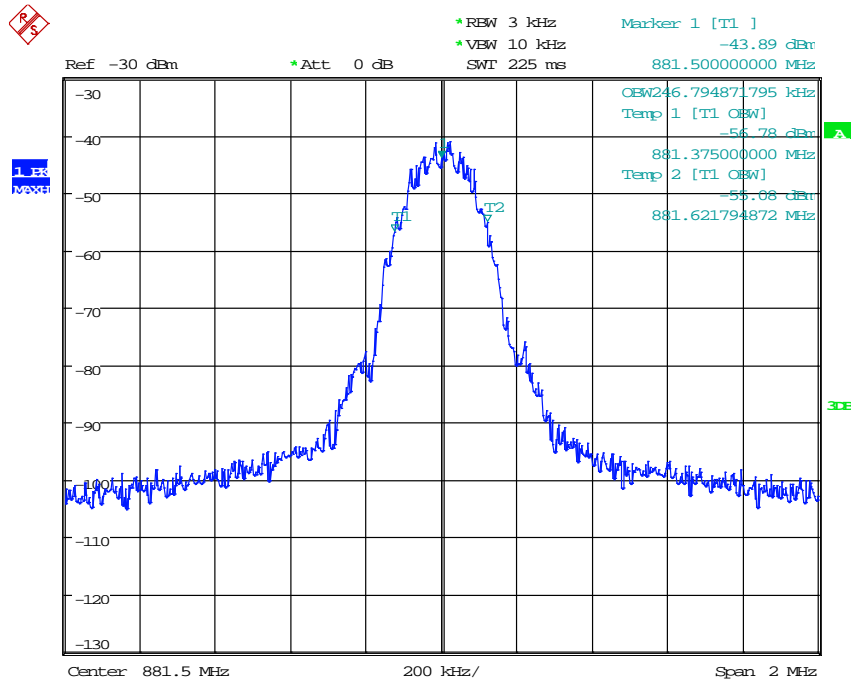

Date: 29.JAN.2016 20:12:03

Fig. 230: Occupied bandwidth for GSM signal in band 5 downlink.

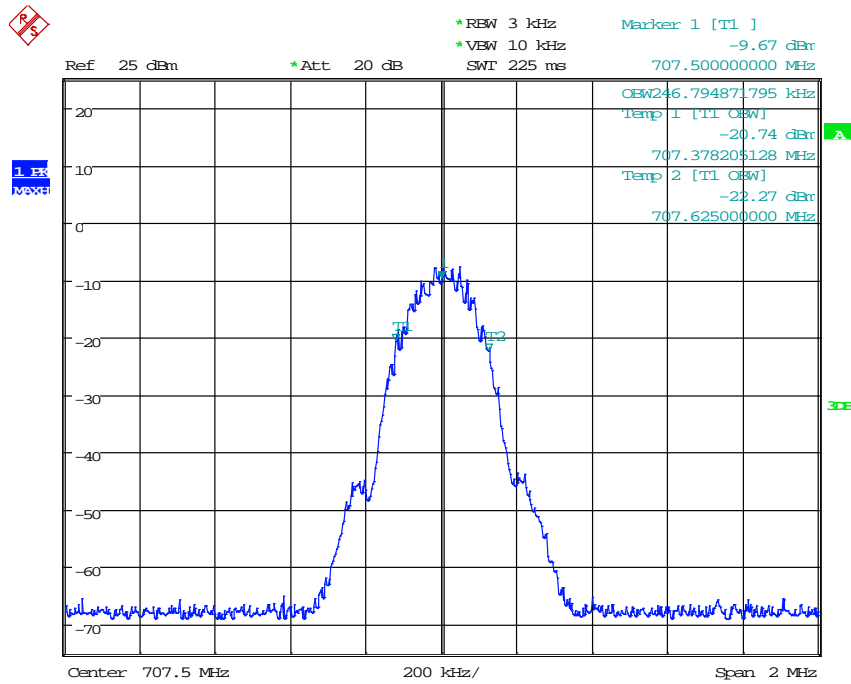

Date: 2.FEB.2016 13:00:17

Fig. 231: Occupied bandwidth for GSM signal when using a through in band 12 uplink.

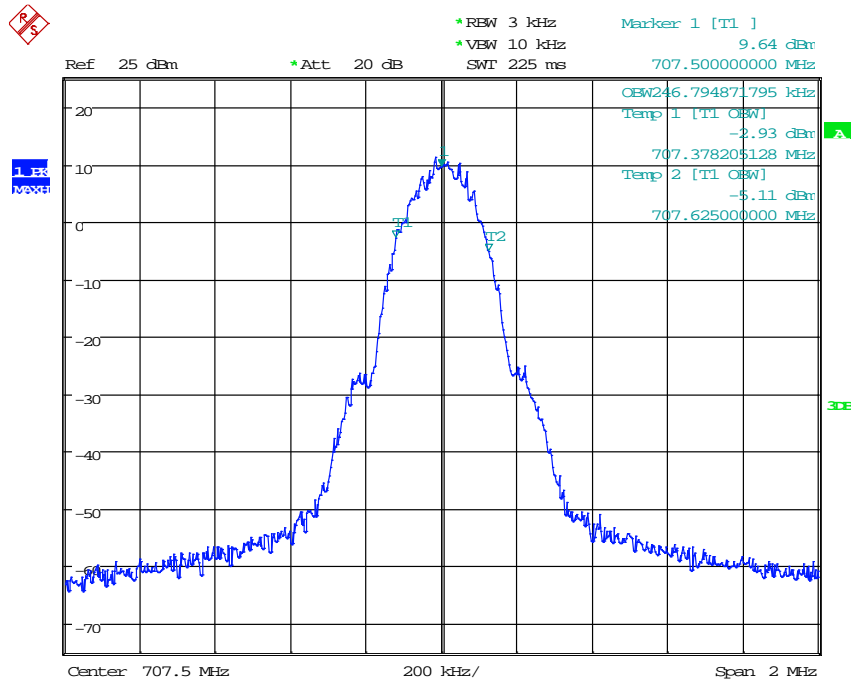

Date: 29.JAN.2016 20:18:06

Fig. 232: Occupied bandwidth for GSM signal in band 12 uplink.

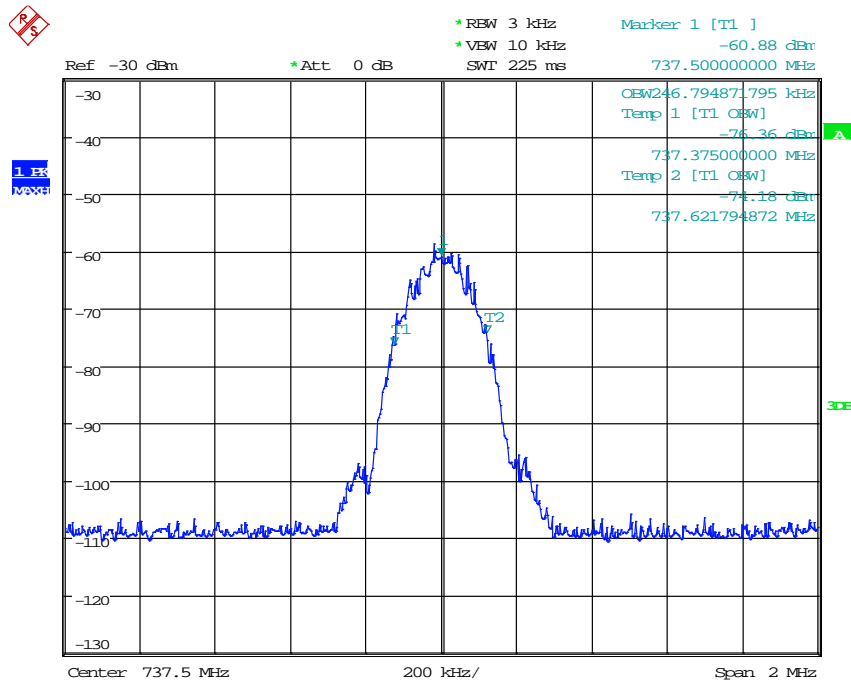

Date: 2.FEB.2016 13:01:31

Fig. 233: Occupied bandwidth for GSM signal when using a through in band 12 downlink.

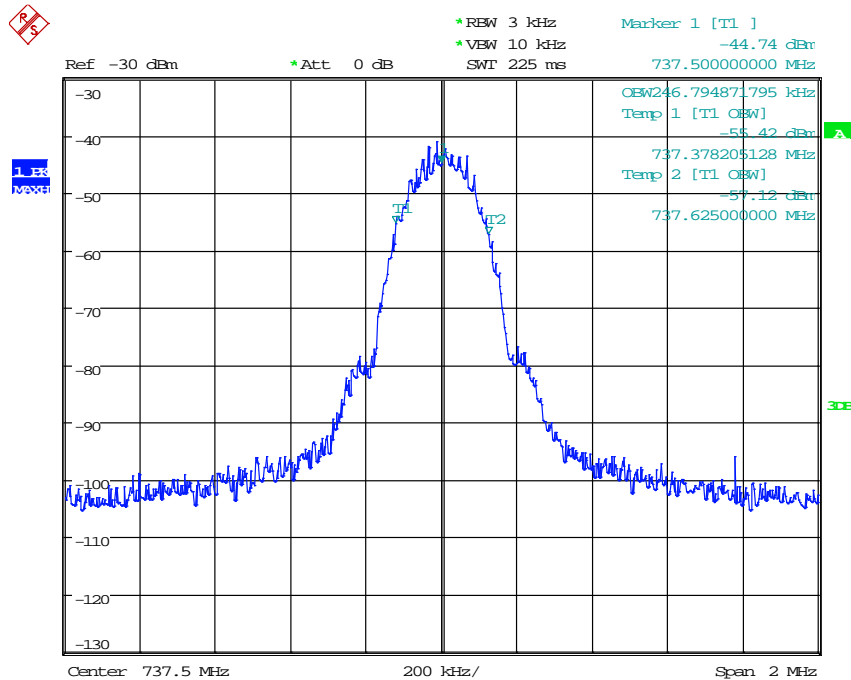

Date: 29.JAN.2016 20:24:56

Fig. 234: Occupied bandwidth for GSM signal in band 12 downlink.

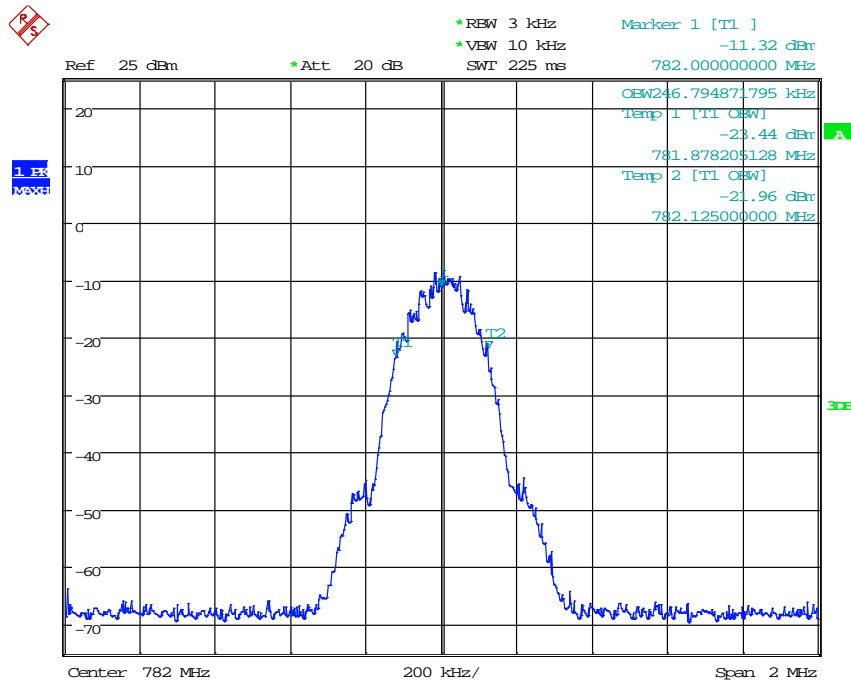

Date: 2.FEB.2016 13:02:44

Fig. 235: Occupied bandwidth for GSM signal when using a through in band 13 uplink.

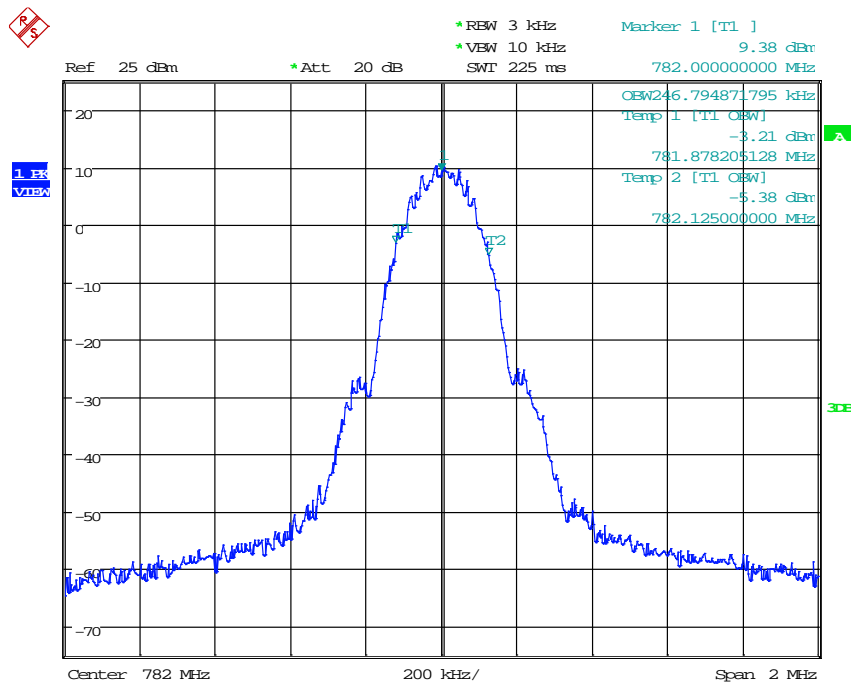

Date: 2.FEB.2016 12:33:37

Fig. 236: Occupied bandwidth for GSM signal in band 13 uplink.

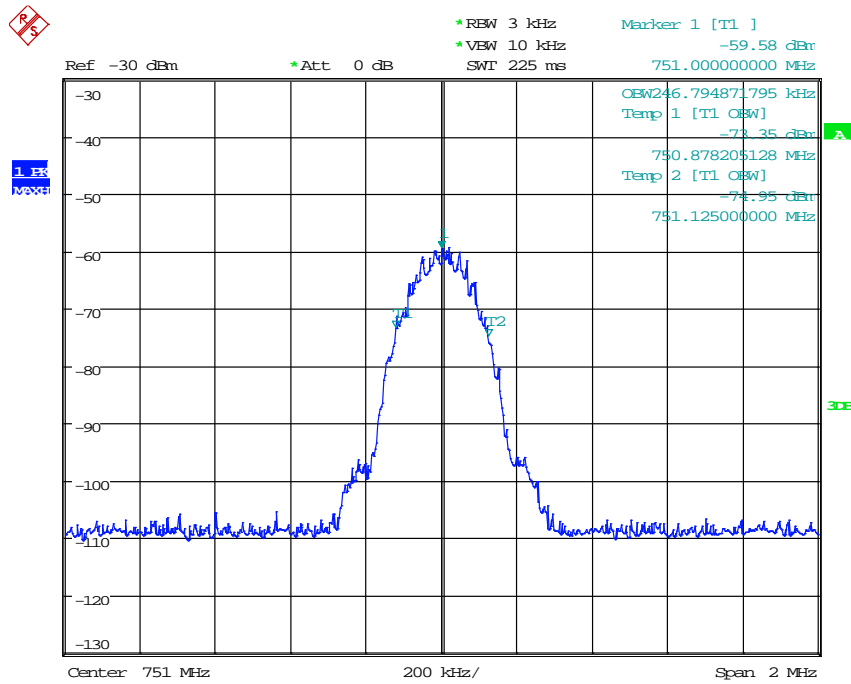

Date: 2.FEB.2016 13:04:08

Fig. 237: Occupied bandwidth for GSM signal when using a through in band 13 downlink.

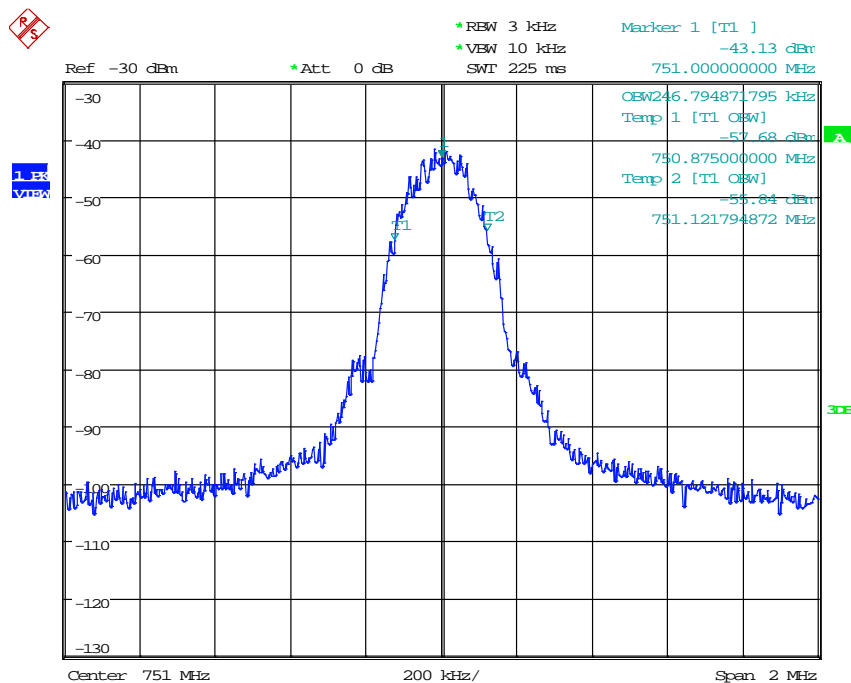

Date: 2.FEB.2016 12:42:44

Fig. 238: Occupied bandwidth for GSM signal in band 13 downlink.

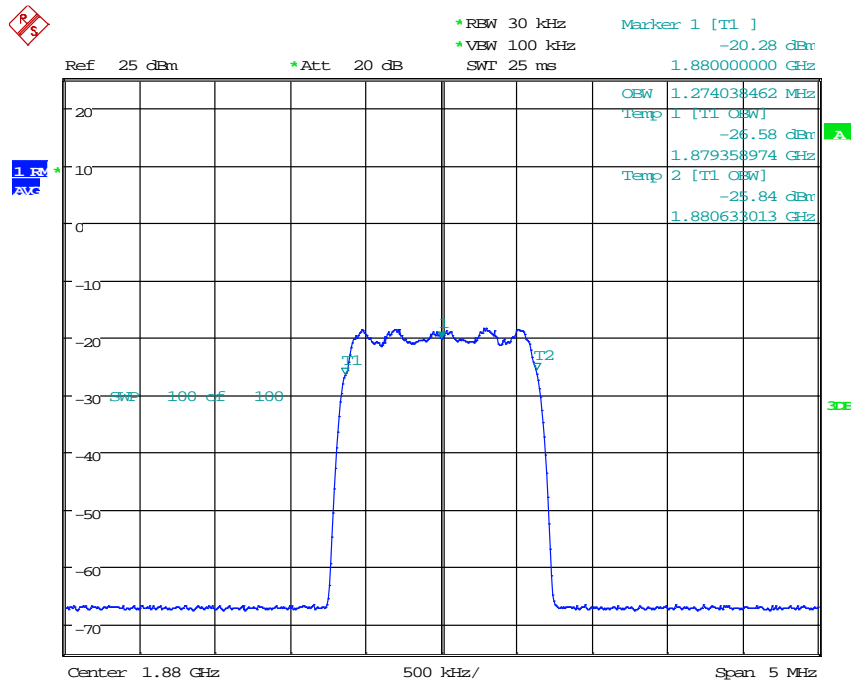

Date: 29.JAN.2016 18:47:13

Fig. 239: Occupied bandwidth for CDMA signal when using a through in band 2 uplink.

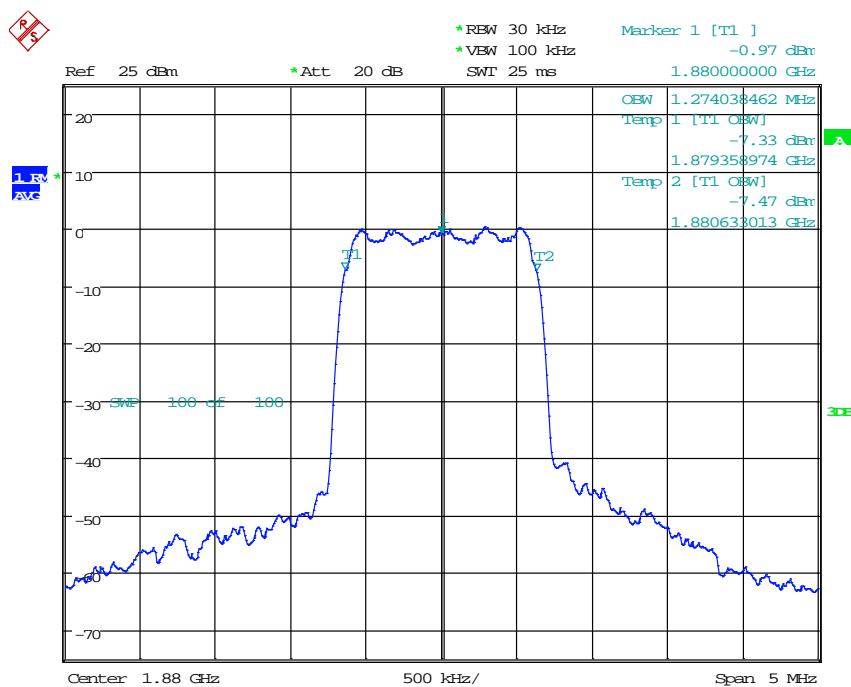

Date: 29.JAN.2016 19:00:49

Fig. 240: Occupied bandwidth for CDMA signal in band 2 uplink.

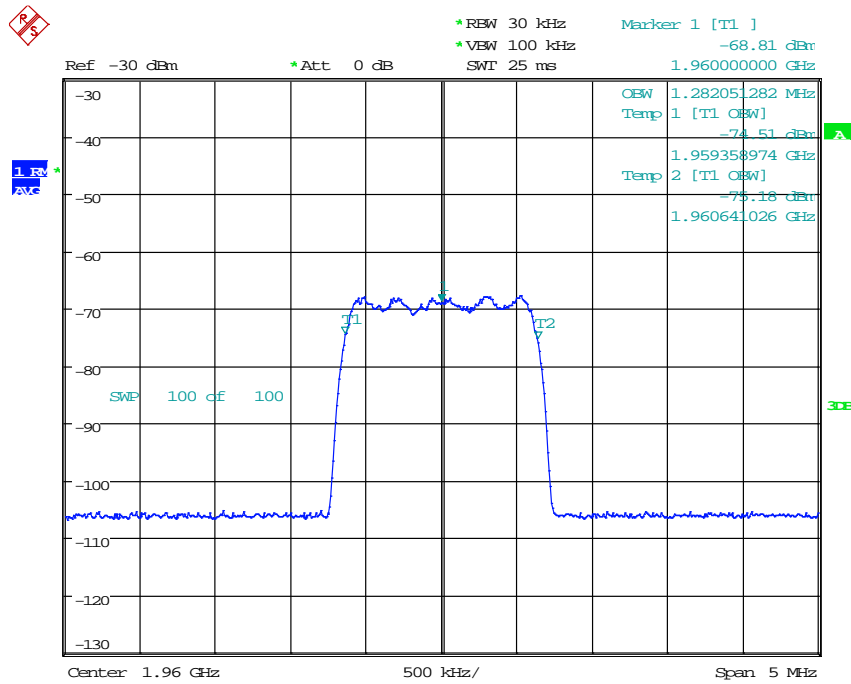

Date: 29.JAN.2016 18:48:00

Fig. 241: Occupied bandwidth for CDMA signal when using a through in band 2 downlink.

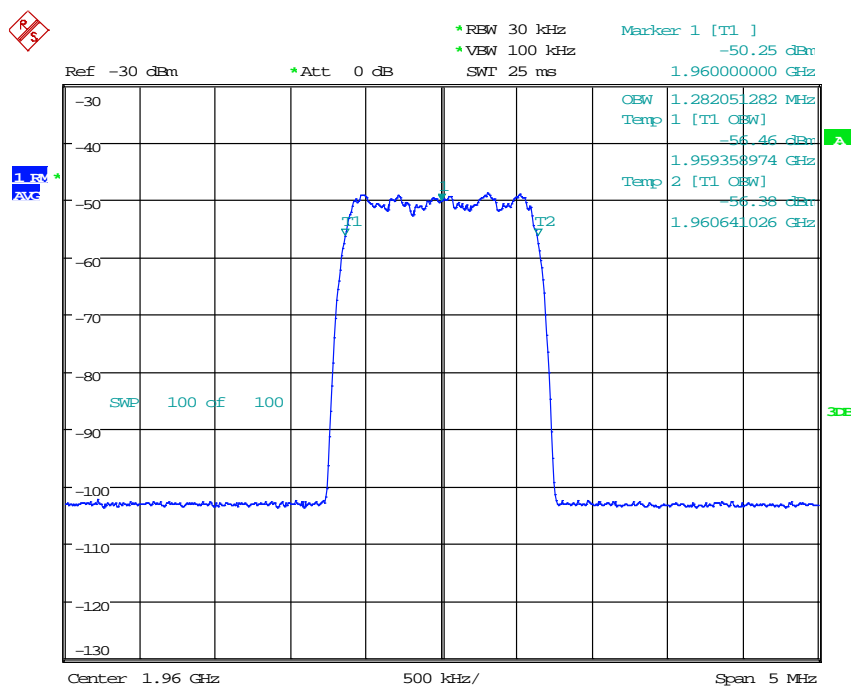

Date: 29.JAN.2016 19:01:21

Fig. 242: Occupied bandwidth for CDMA signal in band 2 downlink.

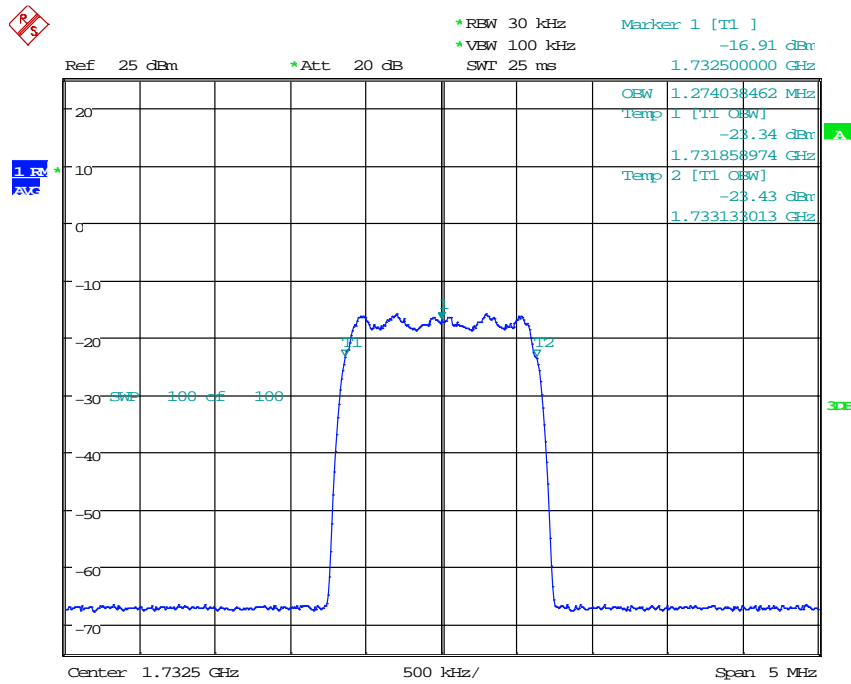

Date: 29.JAN.2016 18:48:36

Fig. 243: Occupied bandwidth for CDMA signal when using a through in band 4 uplink.

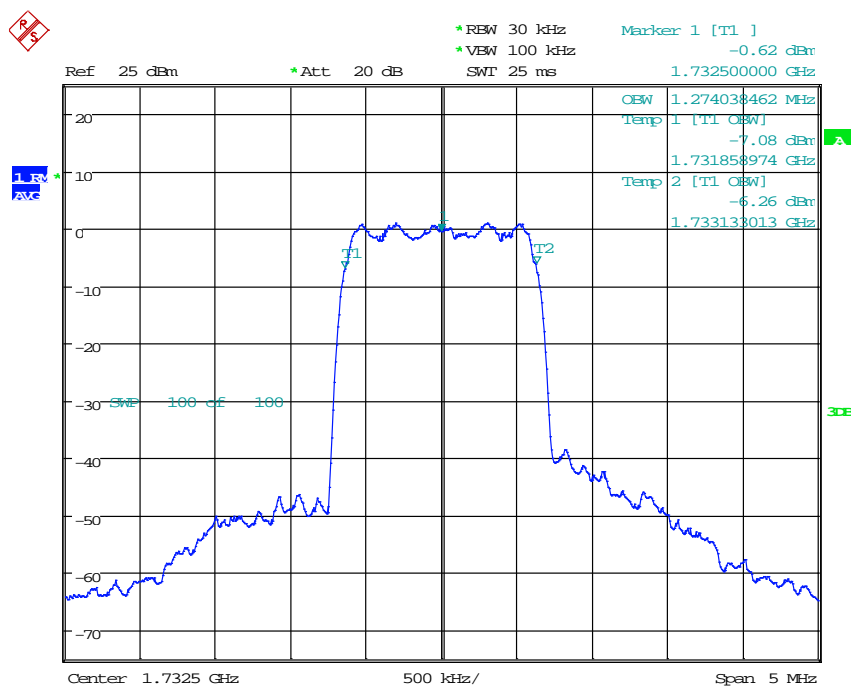

Date: 29.JAN.2016 19:08:53

Fig. 244: Occupied bandwidth for CDMA signal in band 4 uplink.

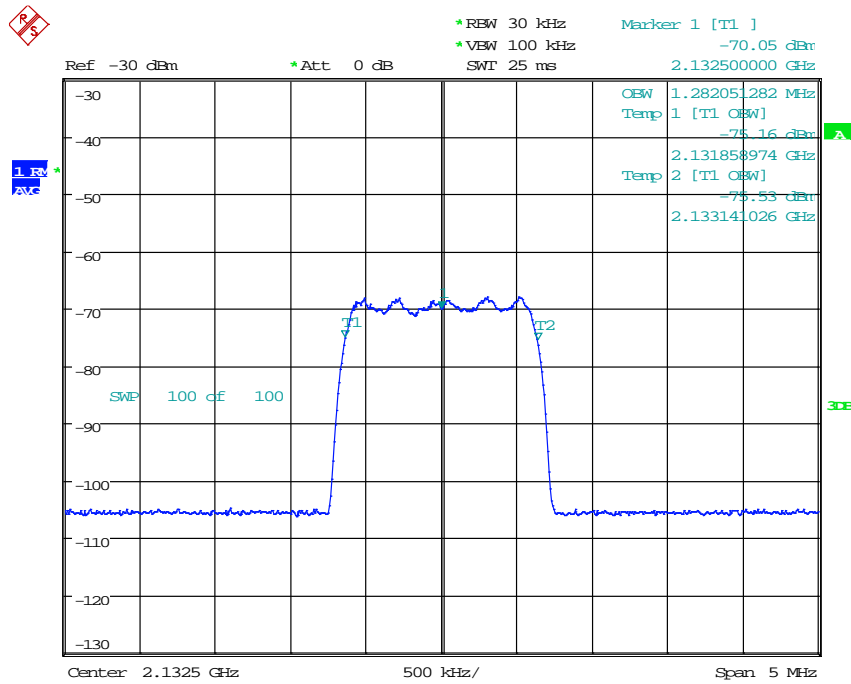

Date: 29.JAN.2016 18:49:08

Fig. 245: Occupied bandwidth for CDMA signal when using a through in band 4 downlink.

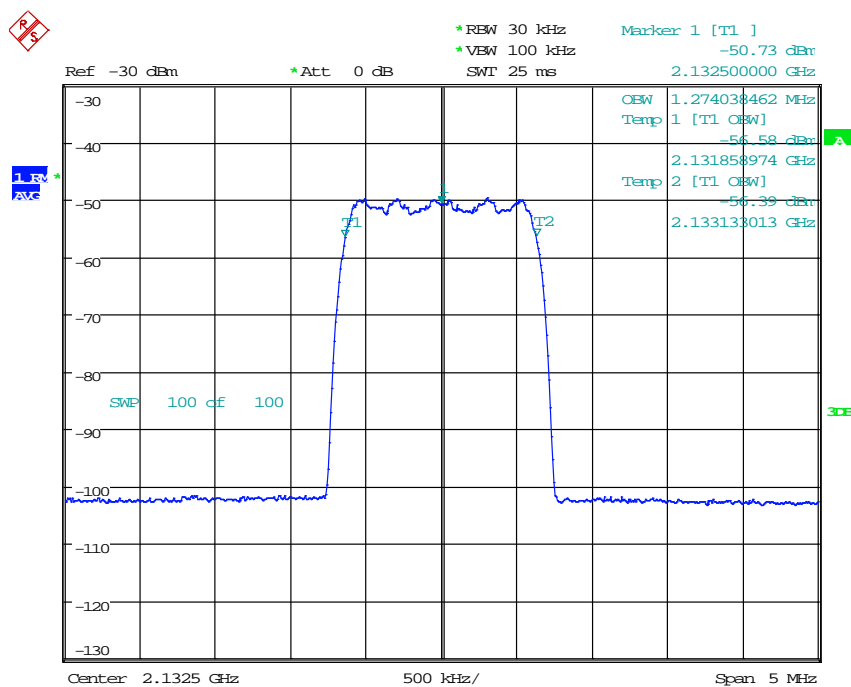

Date: 29.JAN.2016 19:11:29

Fig. 246: Occupied bandwidth for CDMA signal in band 4 downlink.

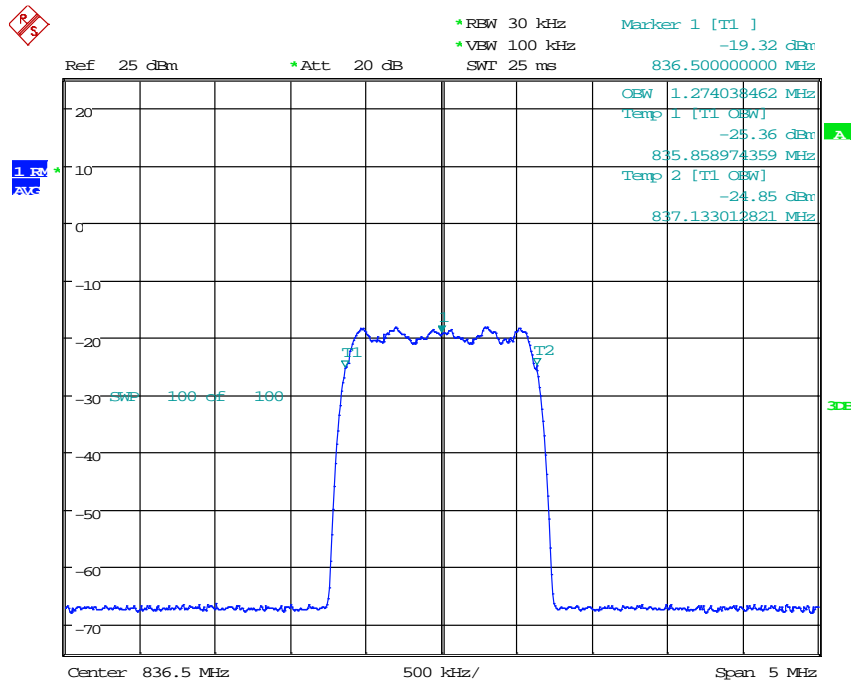

Date: 29.JAN.2016 18:49:41

Fig. 247: Occupied bandwidth for CDMA signal when using a through in band 5 uplink.

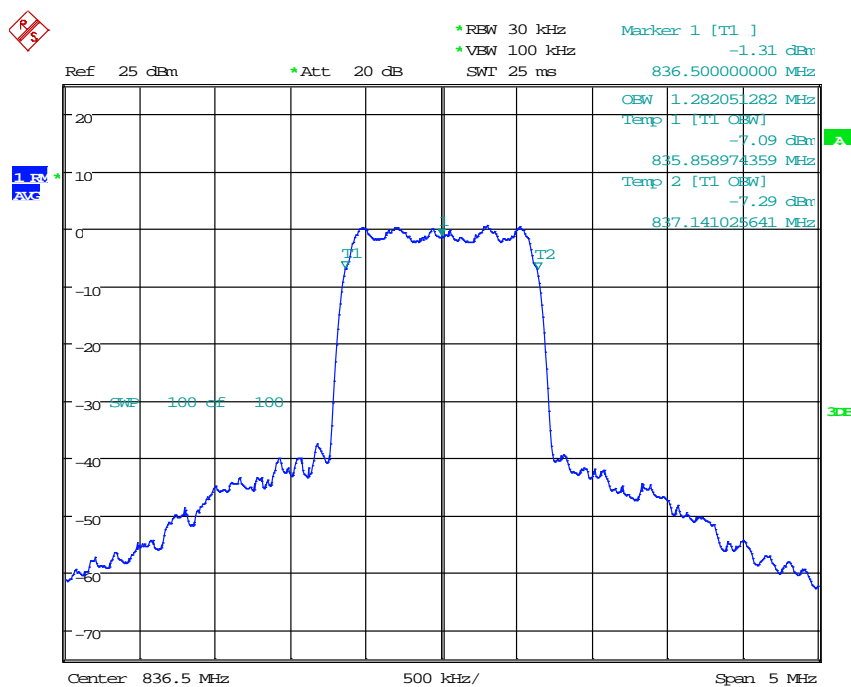

Date: 29.JAN.2016 19:12:07

Fig. 248: Occupied bandwidth for CDMA signal in band 5 uplink.

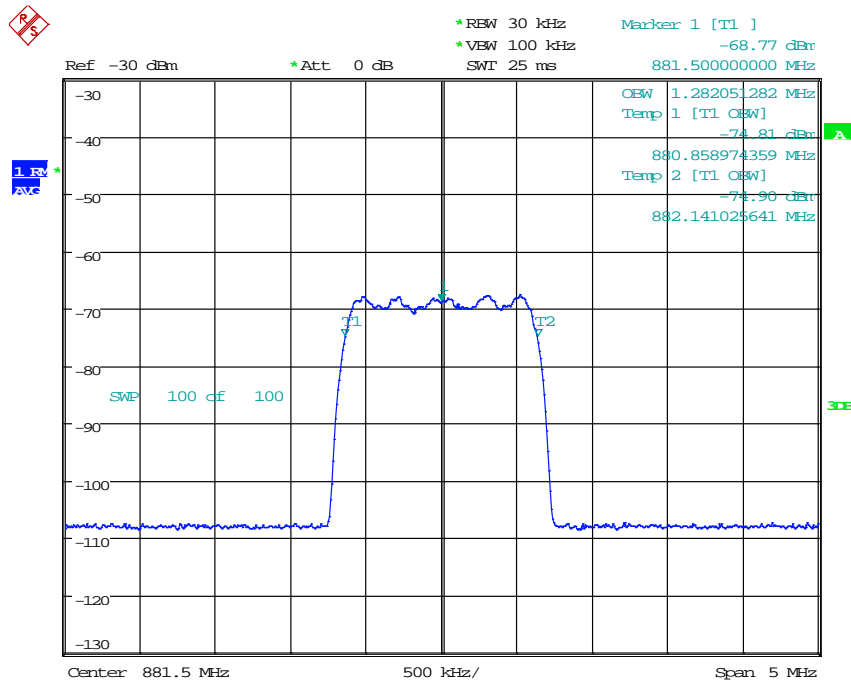

Date: 29.JAN.2016 18:50:23

Fig. 249: Occupied bandwidth for CDMA signal when using a through in band 5 downlink.

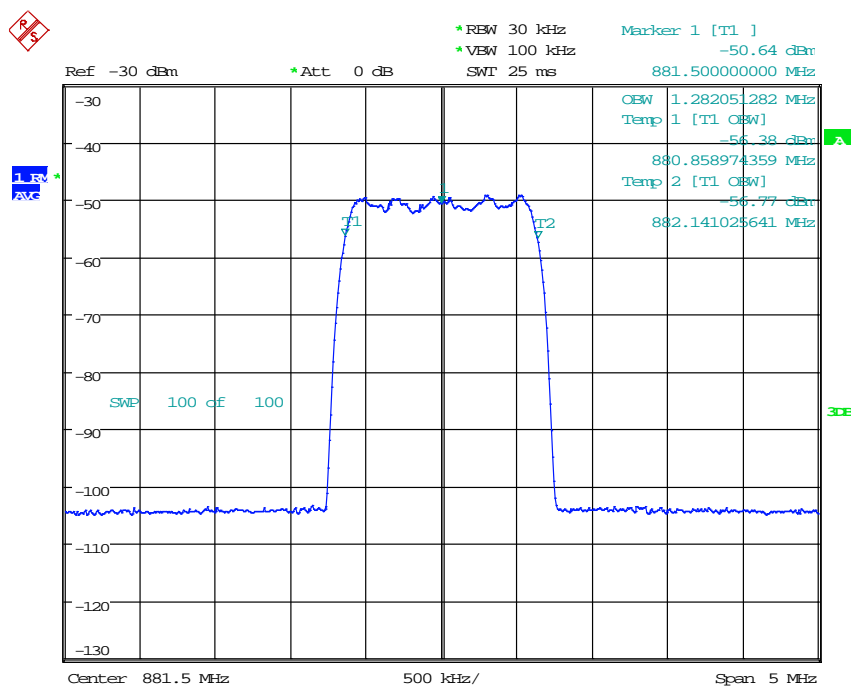

Date: 29.JAN.2016 19:13:37

Fig. 250: Occupied bandwidth for CDMA signal in band 5 downlink.

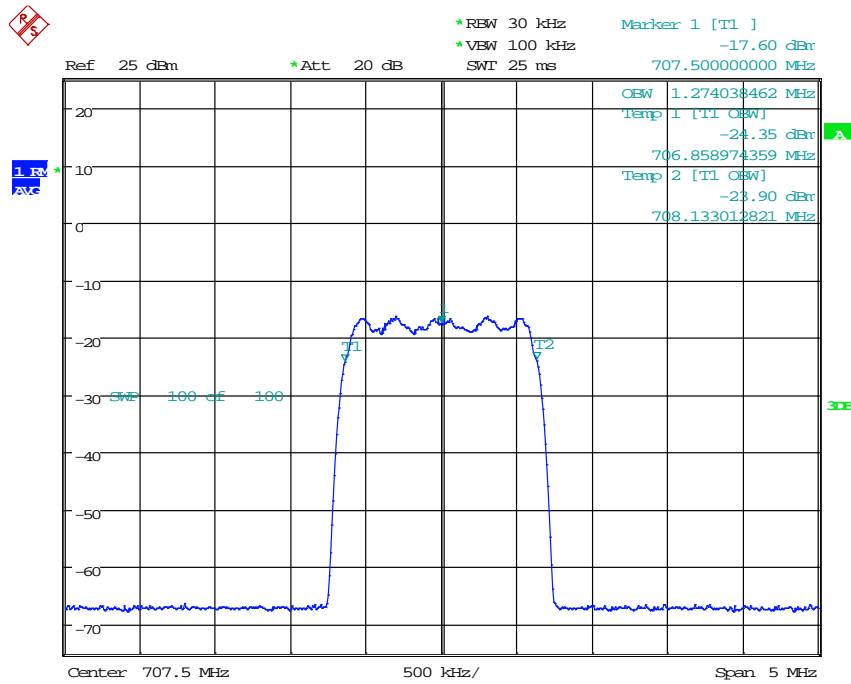

Date: 29.JAN.2016 18:50:47

Fig. 251: Occupied bandwidth for CDMA signal when using a through in band 12 uplink.

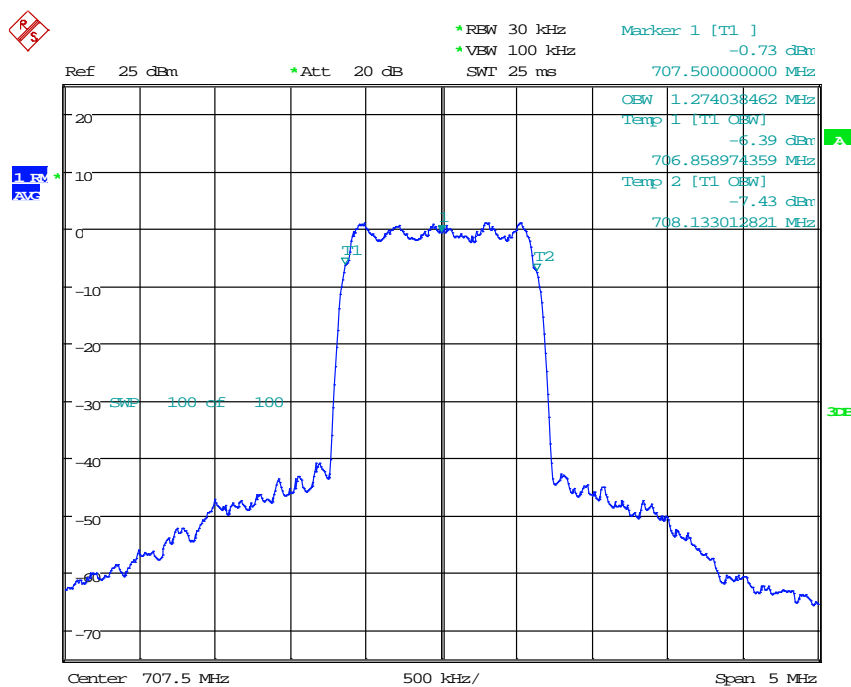

Date: 29.JAN.2016 19:14:02

Fig. 252: Occupied bandwidth for CDMA signal in band 12 uplink.

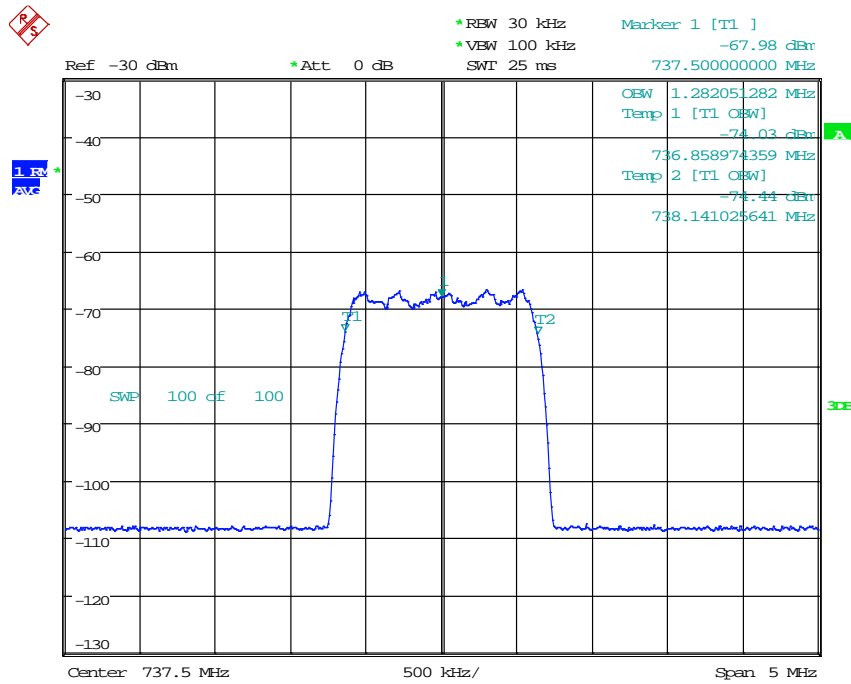

Date: 29.JAN.2016 18:51:21

Fig. 253: Occupied bandwidth for CDMA signal when using a through in band 12 downlink.

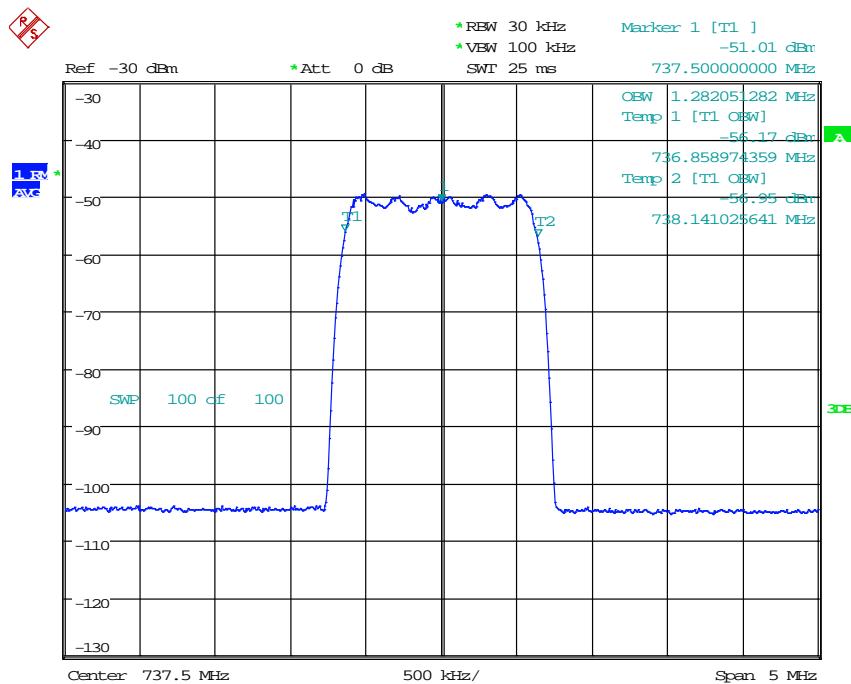

Date: 29.JAN.2016 19:14:31

Fig. 254: Occupied bandwidth for CDMA signal in band 12 downlink.

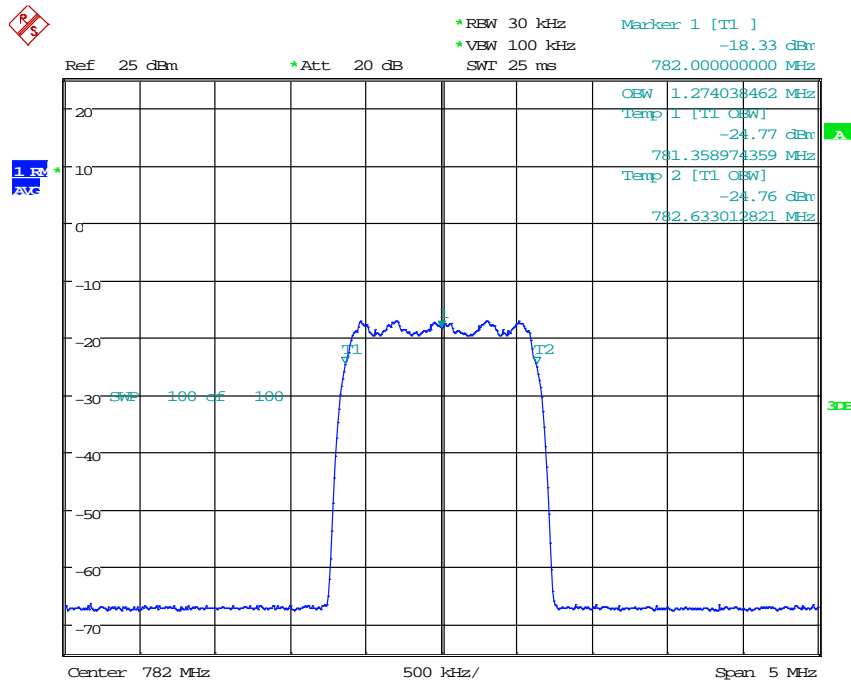

Date: 29.JAN.2016 18:51:49

Fig. 255: Occupied bandwidth for CDMA signal when using a through in band 13 uplink.

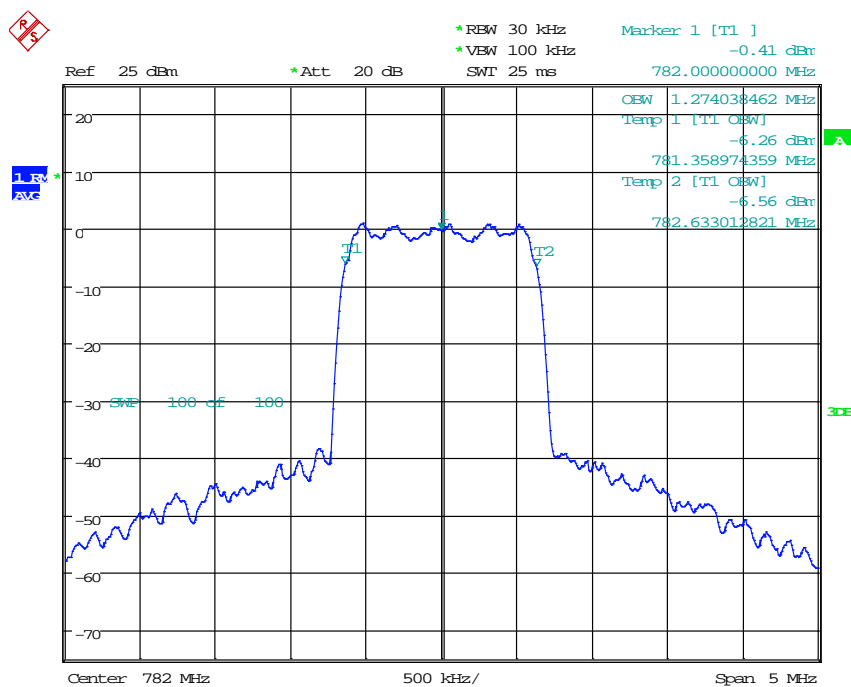

Date: 29.JAN.2016 19:15:13

Fig. 256: Occupied bandwidth for CDMA signal in band 13 uplink.

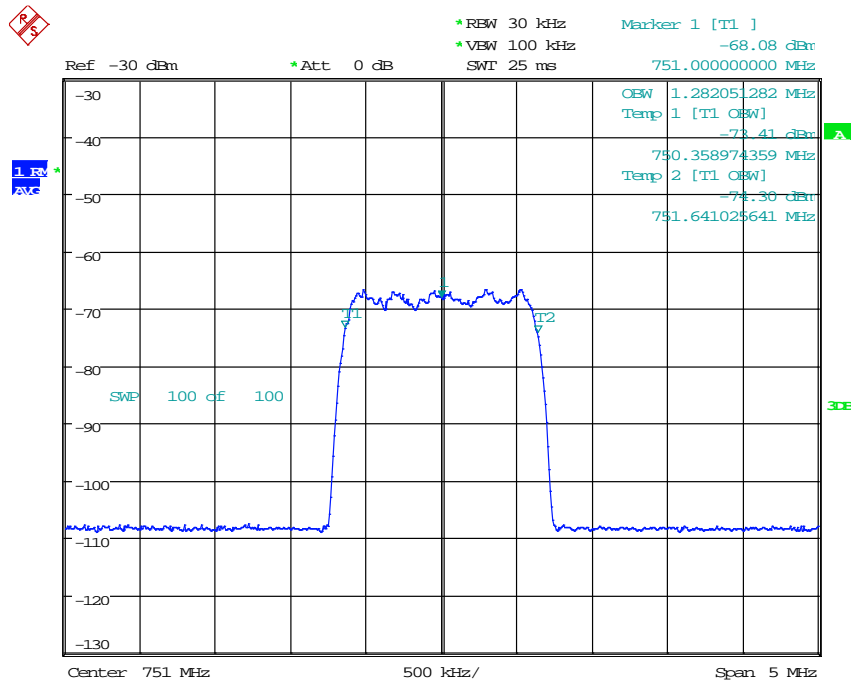

Date: 29.JAN.2016 18:52:51

Fig. 257: Occupied bandwidth for CDMA signal when using a through in band 13 downlink.

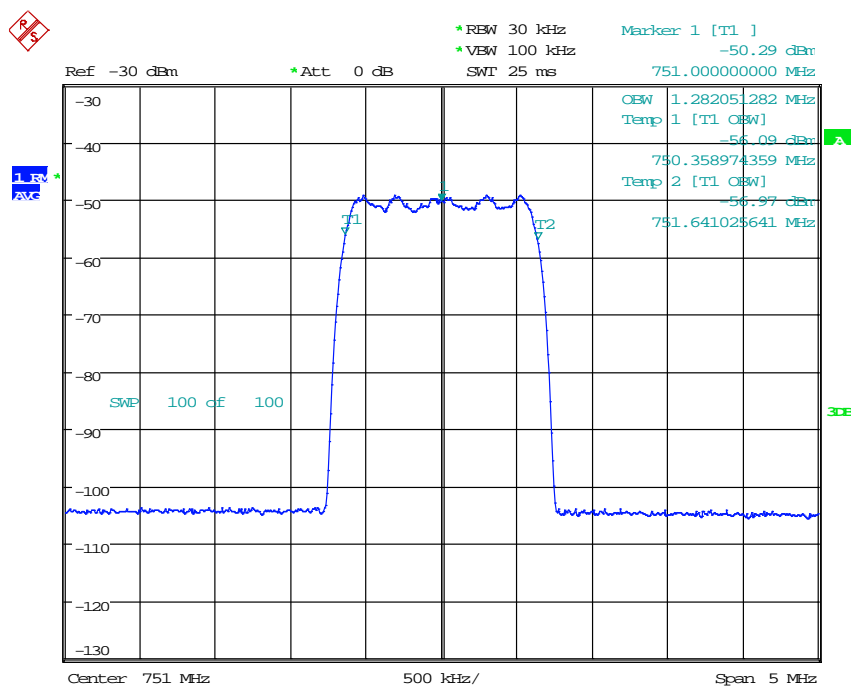

Date: 29.JAN.2016 19:16:10

Fig. 258: Occupied bandwidth for CDMA signal in band 13 downlink.

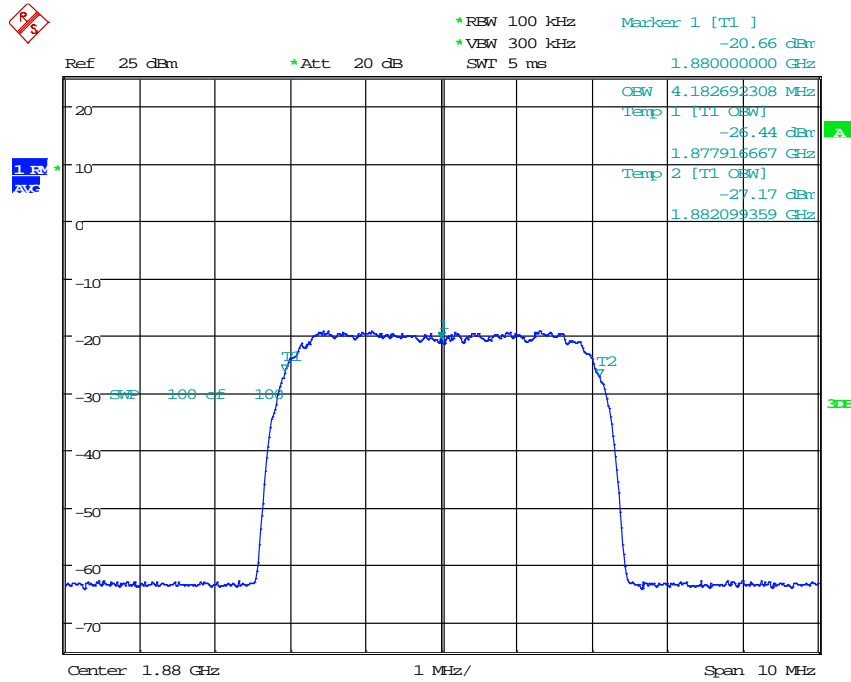

Date: 29.JAN.2016 16:41:50

Fig. 259: Occupied bandwidth for WCDMA signal when using a through in band 2 uplink.

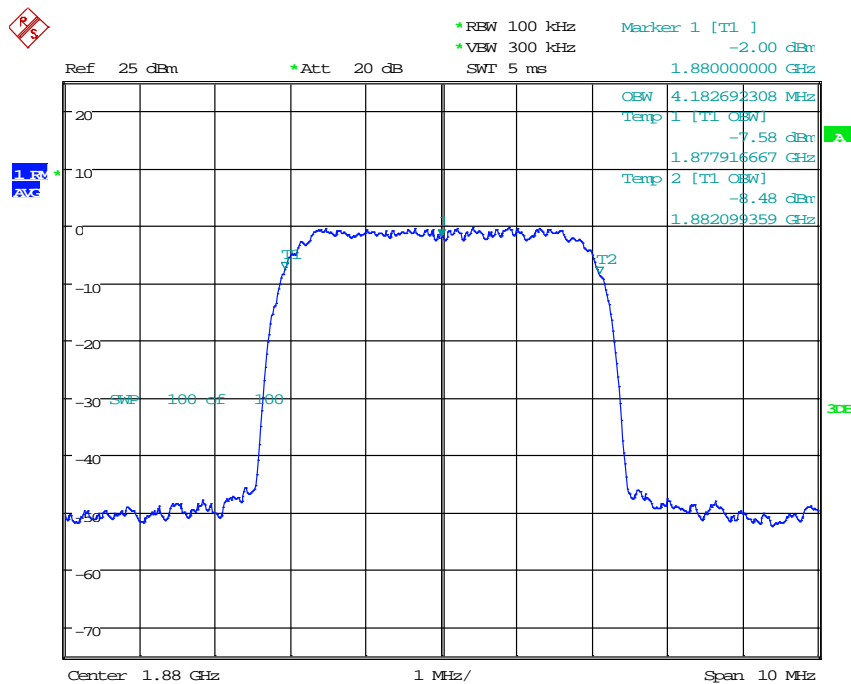

Date: 29.JAN.2016 17:00:56

Fig. 260: Occupied bandwidth for WCDMA signal in band 2 uplink.

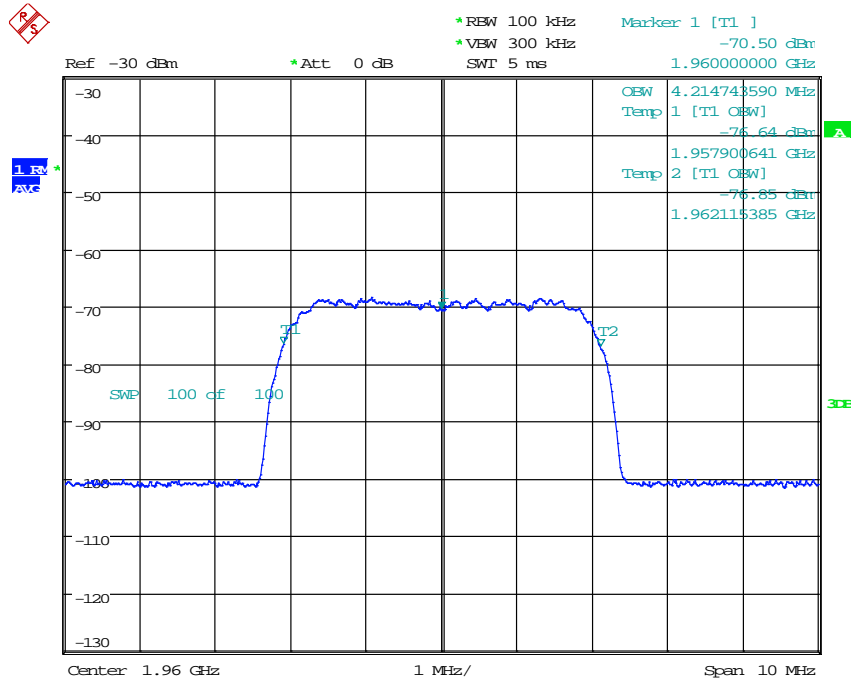

Date: 29.JAN.2016 18:41:13

Fig. 261: Occupied bandwidth for WCDMA signal when using a through in band 2 downlink.

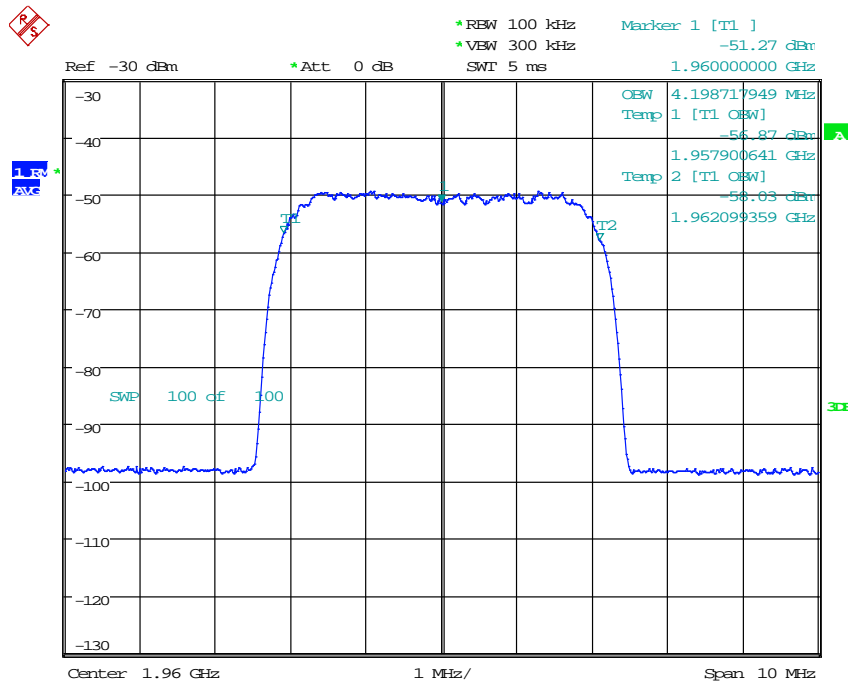

Date: 29.JAN.2016 18:37:38

Fig. 262: Occupied bandwidth for WCDMA signal in band 2 downlink.

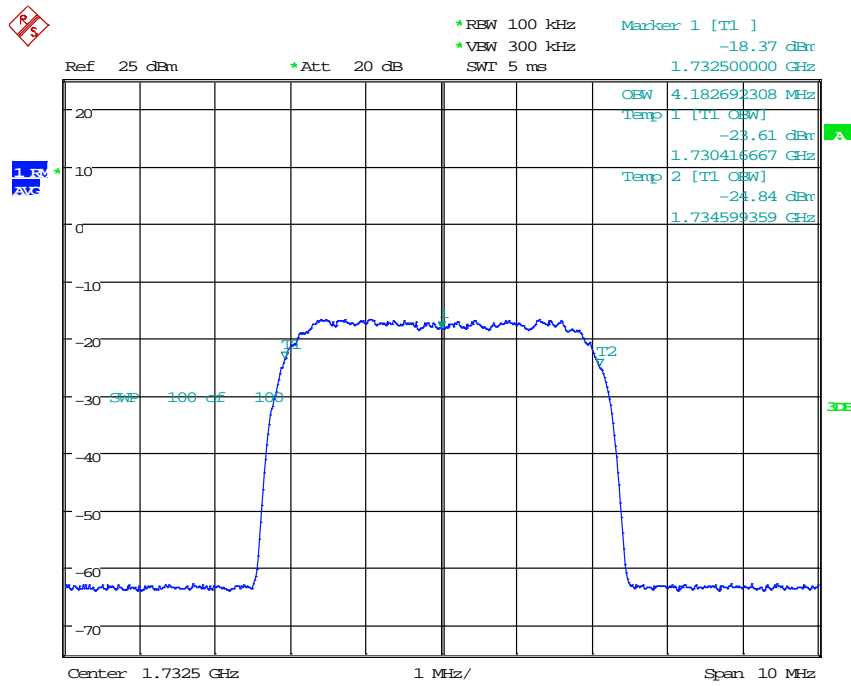

Date: 29.JAN.2016 16:54:52

Fig. 263: Occupied bandwidth for WCDMA signal when using a through in band 4 uplink.

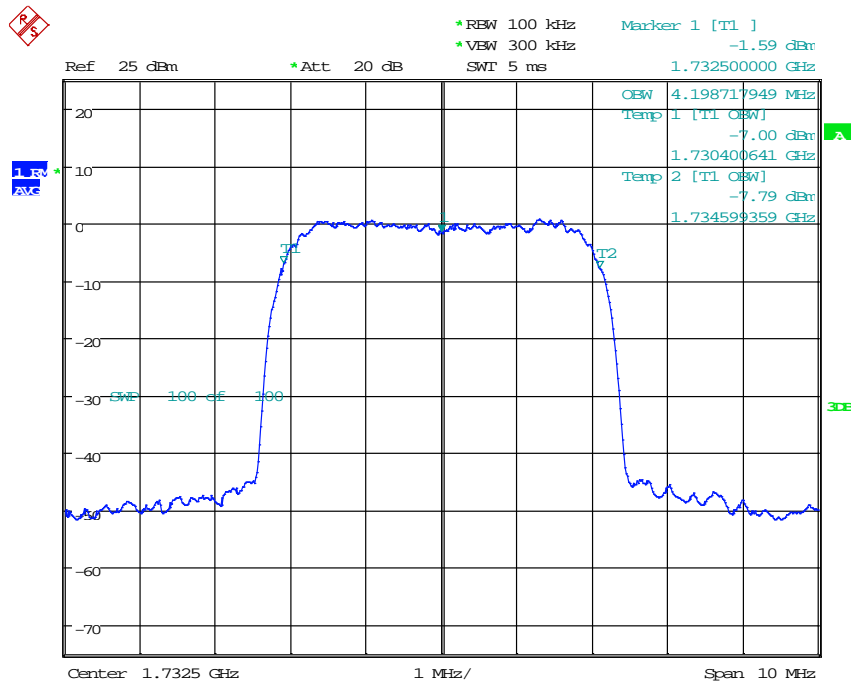

Date: 29.JAN.2016 17:01:45

Fig. 264: Occupied bandwidth for WCDMA signal in band 4 uplink.

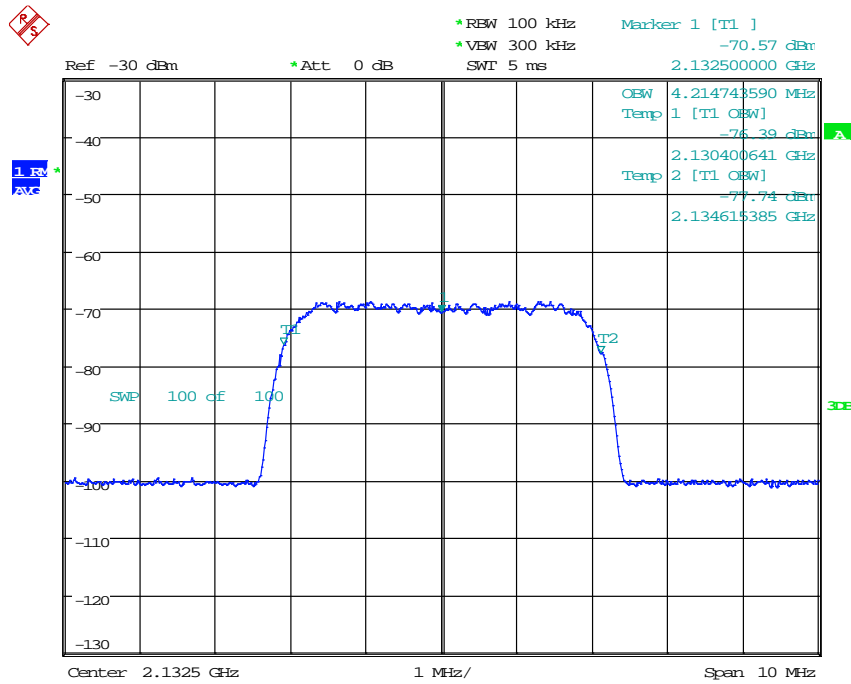

Date: 29.JAN.2016 18:41:46

Fig. 265: Occupied bandwidth for WCDMA signal when using a through in band 4 downlink.

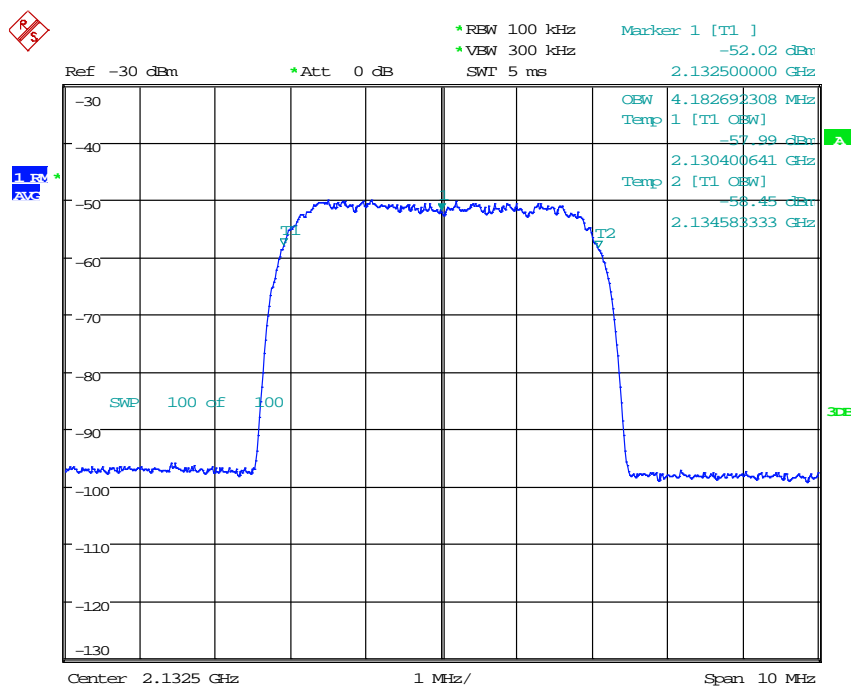

Date: 29.JAN.2016 18:36:30

Fig. 266: Occupied bandwidth for WCDMA signal in band 4 downlink.

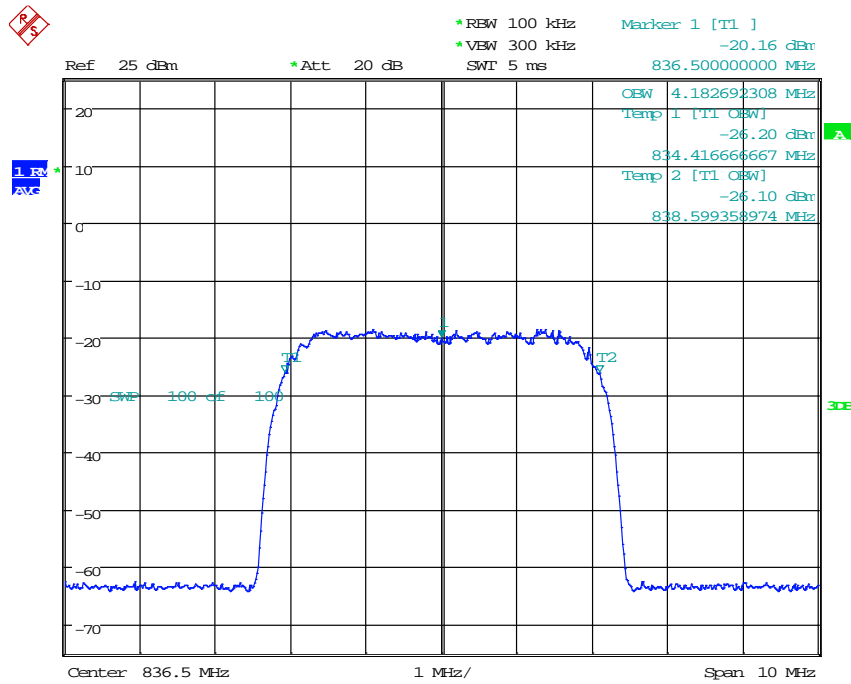

Date: 29.JAN.2016 16:55:55

Fig. 267: Occupied bandwidth for WCDMA signal when using a through in band 5 uplink.

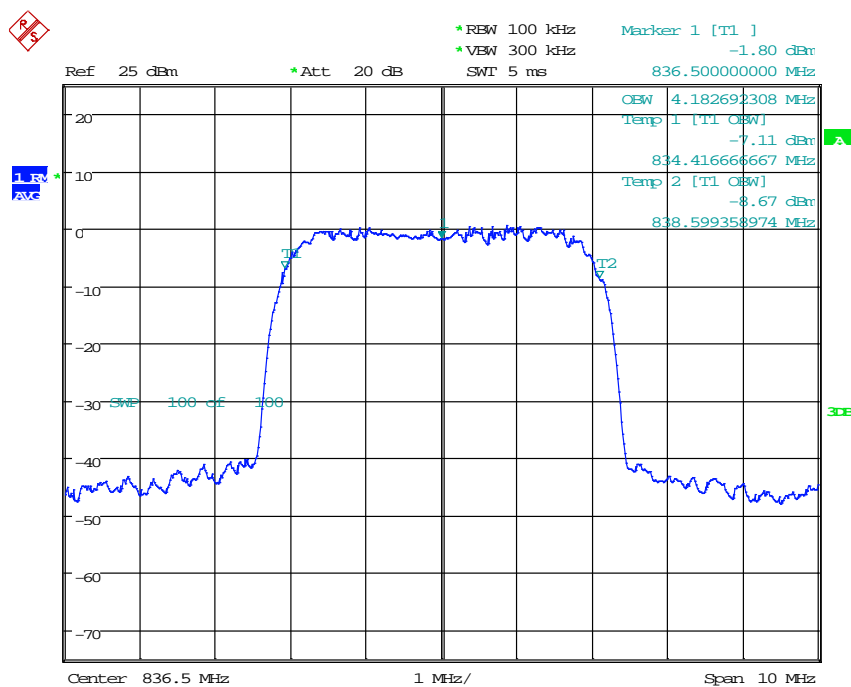

Date: 29.JAN.2016 17:02:56

Fig. 268: Occupied bandwidth for WCDMA signal in band 5 uplink.

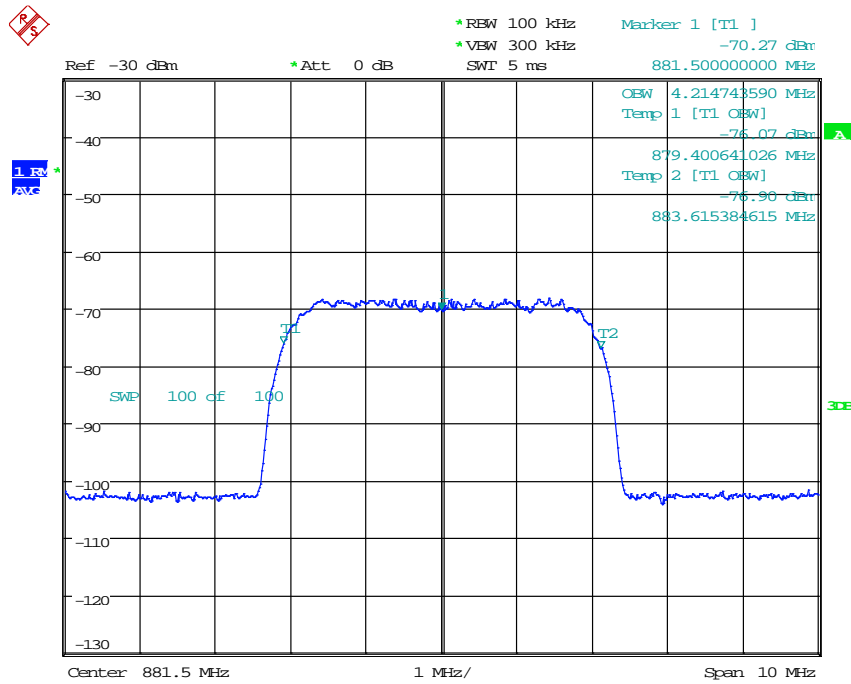

Date: 29.JAN.2016 18:42:32

Fig. 269: Occupied bandwidth for WCDMA signal when using a through in band 5 downlink.

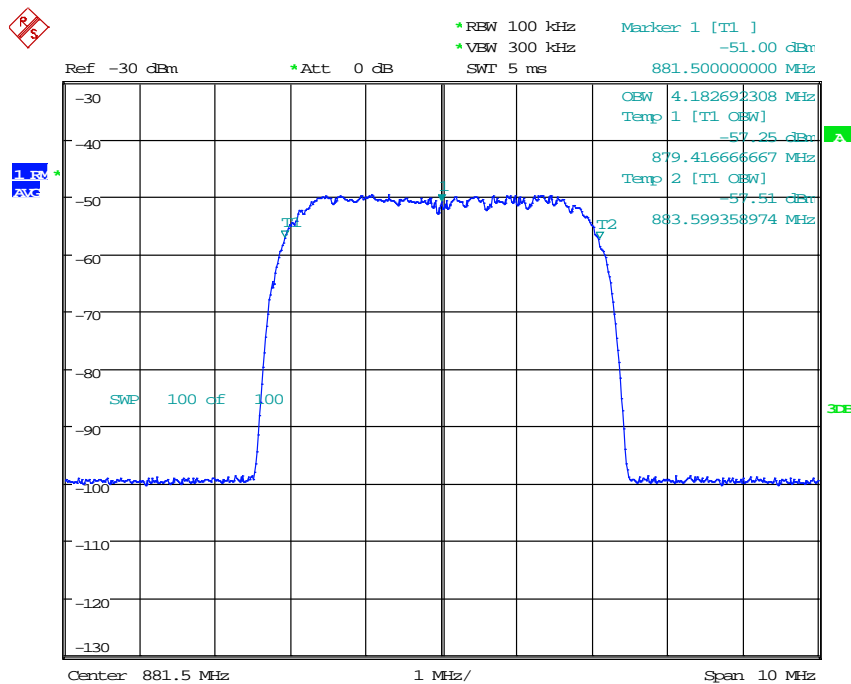

Date: 29.JAN.2016 18:38:10

Fig. 270: Occupied bandwidth for WCDMA signal in band 5 downlink.

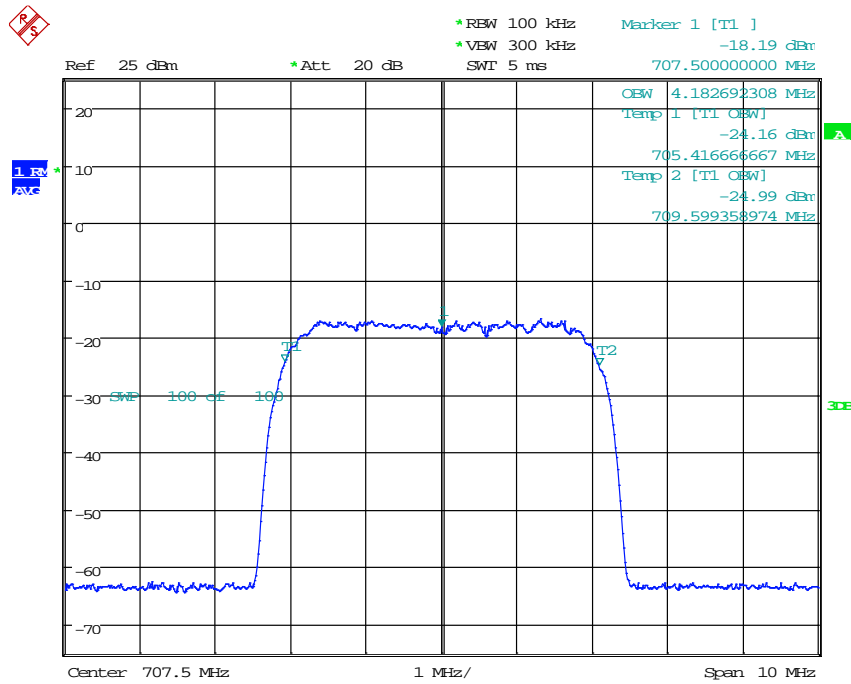

Date: 29.JAN.2016 16:57:45

Fig. 271: Occupied bandwidth for WCDMA signal when using a through in band 12 uplink.

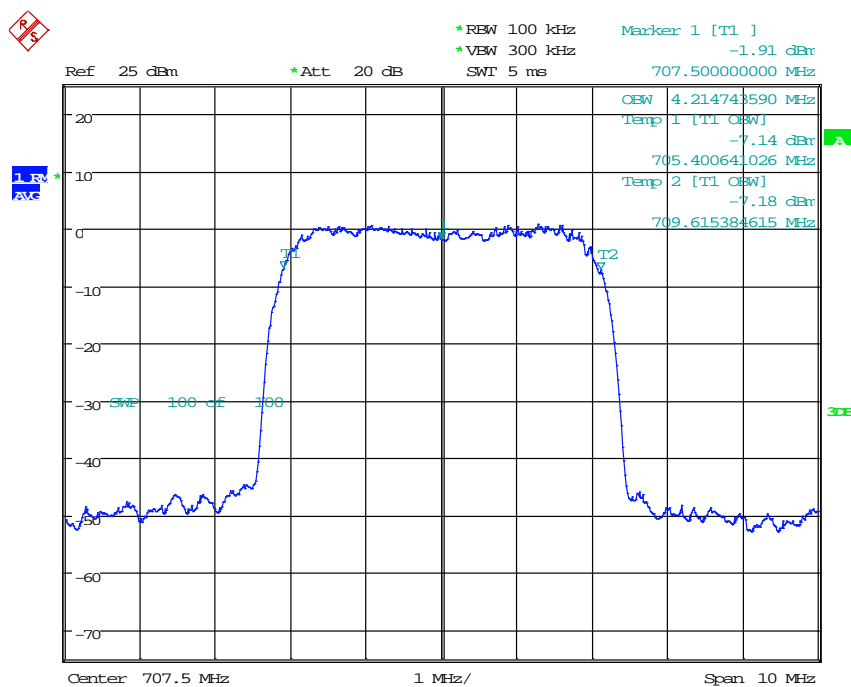

Date: 29.JAN.2016 17:08:39

Fig. 272: Occupied bandwidth for WCDMA signal in band 12 uplink.

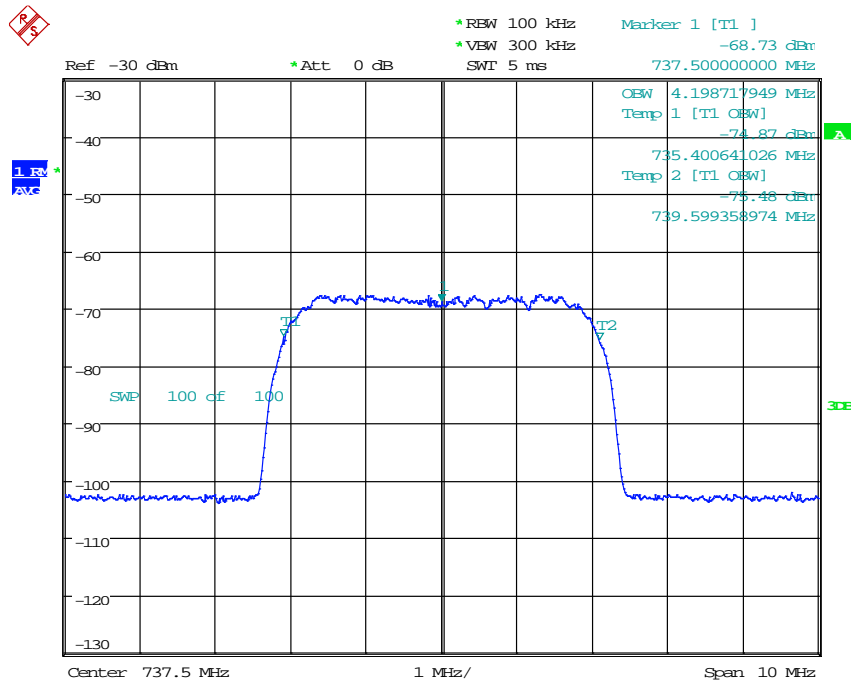

Date: 29.JAN.2016 18:43:01

Fig. 273: Occupied bandwidth for WCDMA signal when using a through in band 12 downlink.

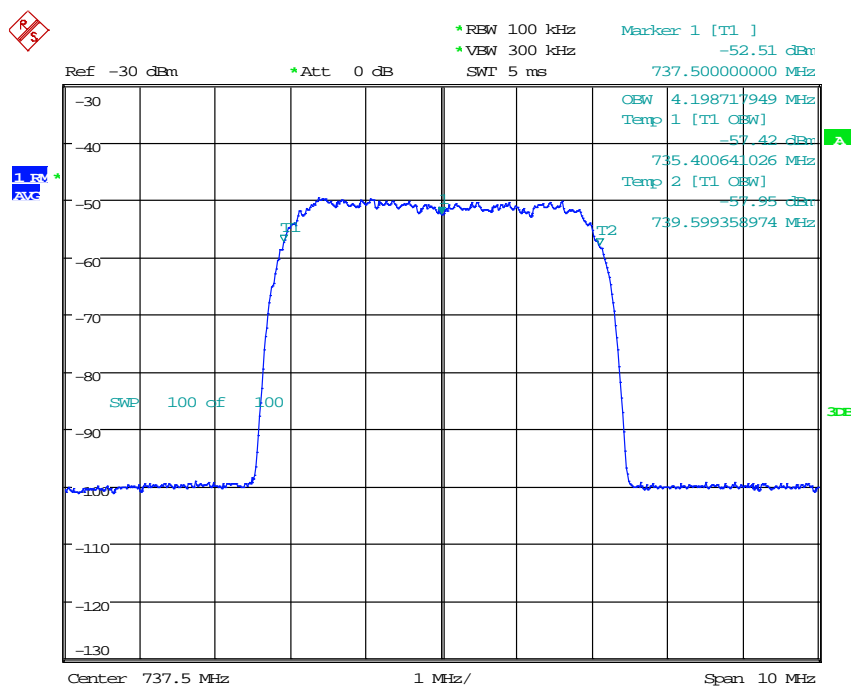

Date: 29.JAN.2016 18:38:42

Fig. 274: Occupied bandwidth for WCDMA signal in band 12 downlink.

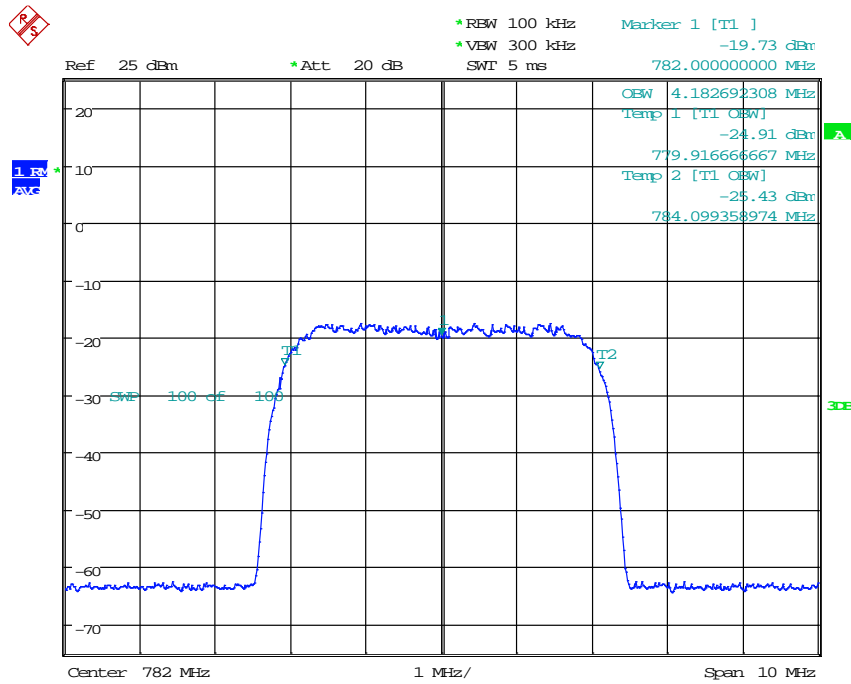

Date: 29.JAN.2016 16:58:35

Fig. 275: Occupied bandwidth for WCDMA signal when using a through in band 13 uplink.

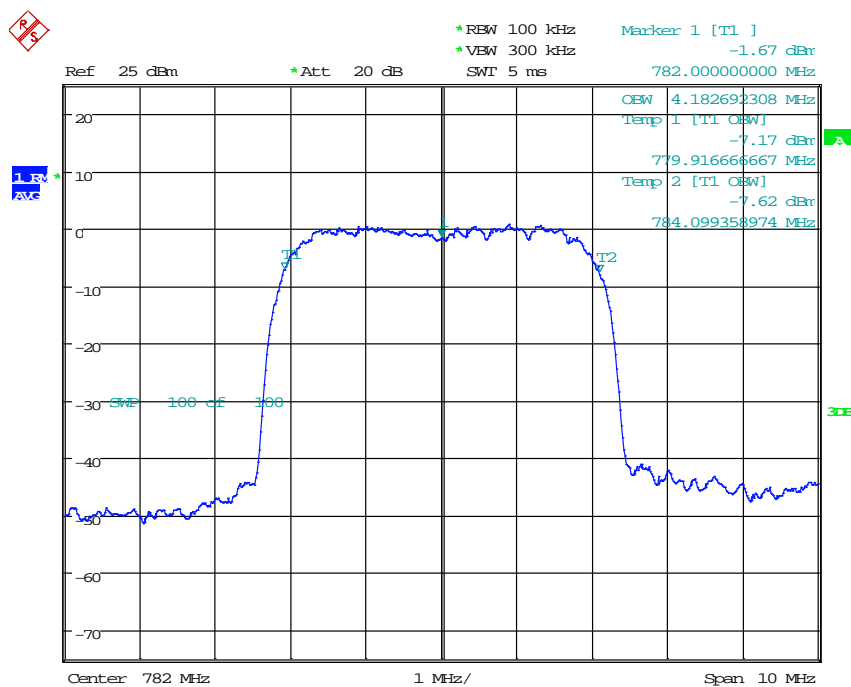

Date: 29.JAN.2016 17:09:45

Fig. 276: Occupied bandwidth for WCDMA signal in band 13 uplink.

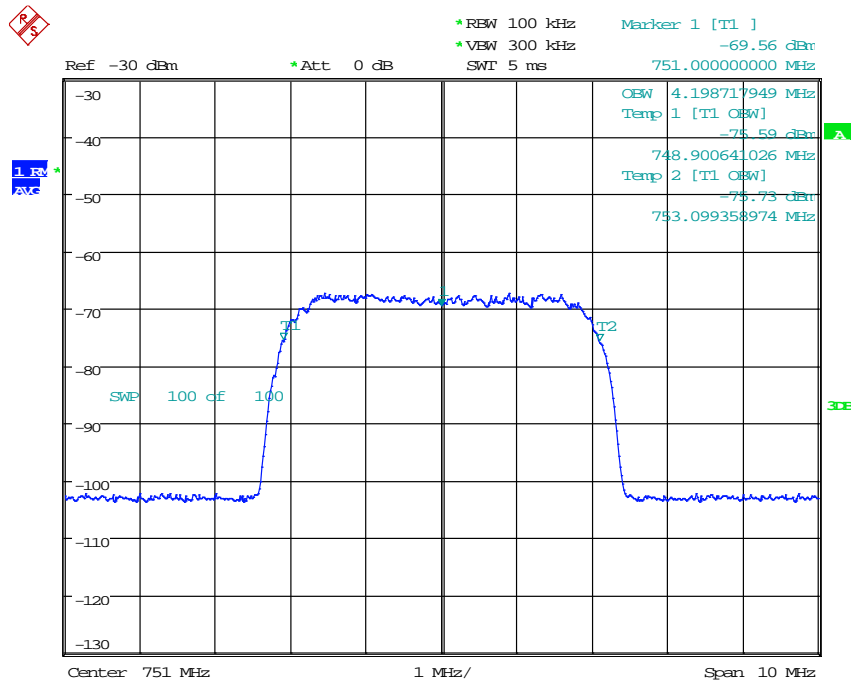

Date: 29.JAN.2016 18:43:31

Fig. 277: Occupied bandwidth for WCDMA signal when using a through in band 13 downlink.

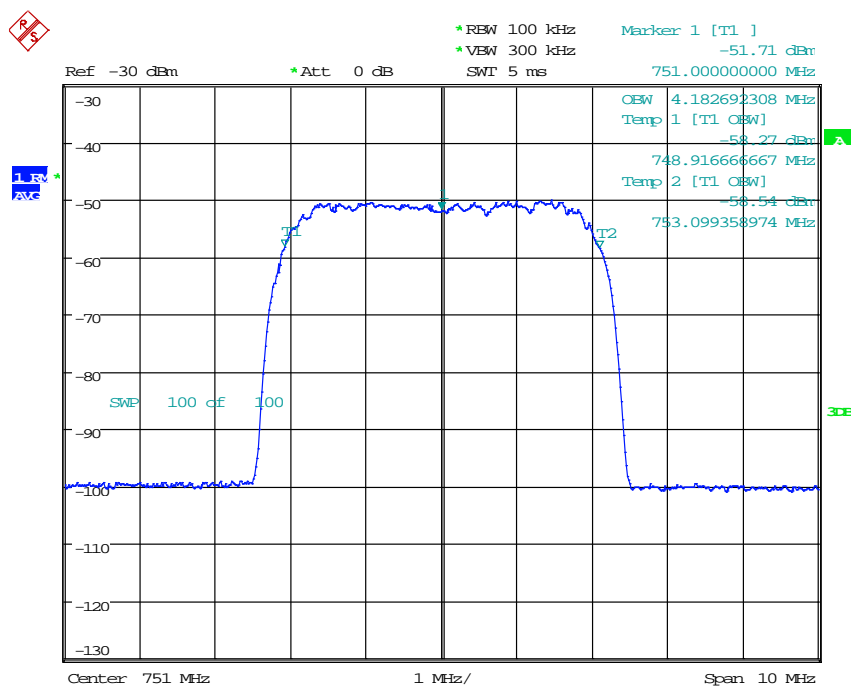

Date: 29.JAN.2016 18:39:36

Fig. 278: Occupied bandwidth for WCDMA signal in band 13 downlink.

5.11. Oscillation Detection and Mitigation Test

5.11.1 Oscillation Restart Tests

For measuring the capability of the EUT to detect the presence of oscillation and to turn off then the output power within 300 ms for the uplink and 1000 ms for the downlink and remain off for one minute before restart the test setup as shown in Fig. 279 and for the downlink in Fig. 280 has been used.

Below are summarized the measured results for uplink and downlink oscillation detection time test limits

Band	direction	Frequency range	Measured Time	Limit	Result
2	up	1850 MHz – 1910 MHz	200.6 ms	300 ms	Pass
4	up	1710 MHz – 1755 MHz	200.6 ms	300 ms	Pass
5	up	824 MHz – 849 MHz	200.6 ms	300 ms	Pass
12	up	699 MHz – 716 MHz	200.6 ms	300 ms	Pass
13	up	777 MHz – 787 MHz	200.6 ms	300 ms	Pass
2	down	1930 MHz -1990 MHz	101.8 ms	1000 ms	Pass
4	down	2110 MHz – 2155 MHz	101.8 ms	1000 ms	Pass
5	down	868 MHz – 894 MHz	92.8 ms	1000 ms	Pass
12	down	729 MHz -746 MHz	92.8 ms	1000 ms	Pass
13	down	746 MHz -768 MHz	92.8 ms	1000 ms	Pass

Below are summarized the measured results for uplink and downlink restart time test limits

Band	direction	Frequency range	Measured Time	Limit	Result
2	up	1850 MHz – 1910 MHz	63.2 s	≥60 s	Pass
4	up	1710 MHz – 1755 MHz	63.2 s	≥60 s	Pass
5	up	824 MHz – 849 MHz	63.2 s	≥60 s	Pass
12	up	699 MHz – 716 MHz	63.2 s	≥60 s	Pass
13	up	777 MHz – 787 MHz	63.2 s	≥60 s	Pass
2	down	1930 MHz -1990 MHz	63.2 s	≥60 s	Pass
4	down	2110 MHz – 2155 MHz	63.2 s	≥60 s	Pass
5	down	868 MHz – 894 MHz	63.2 s	≥60 s	Pass
12	down	729 MHz -746 MHz	63.2 s	≥60 s	Pass
13	down	746 MHz -768 MHz	63.2 s	≥60 s	Pass

Below are summarized the measured results for uplink and downlink restart attempts

Band	direction	Frequency range	Restarts	Limit	Result
2	up	1850 MHz – 1910 MHz	4	≤ 5	Pass
4	up	1710 MHz – 1755 MHz	4	≤ 5	Pass
5	up	824 MHz – 849 MHz	4	≤ 5	Pass
12	up	699 MHz – 716 MHz	4	≤ 5	Pass
13	up	777 MHz – 787 MHz	4	≤ 5	Pass
2	down	1930 MHz -1990 MHz	4	≤ 5	Pass
4	down	2110 MHz – 2155 MHz	4	≤ 5	Pass
5	down	868 MHz – 894 MHz	4	≤ 5	Pass
12	down	729 MHz -746 MHz	4	≤ 5	Pass
13	down	746 MHz -768 MHz	4	≤ 5	Pass

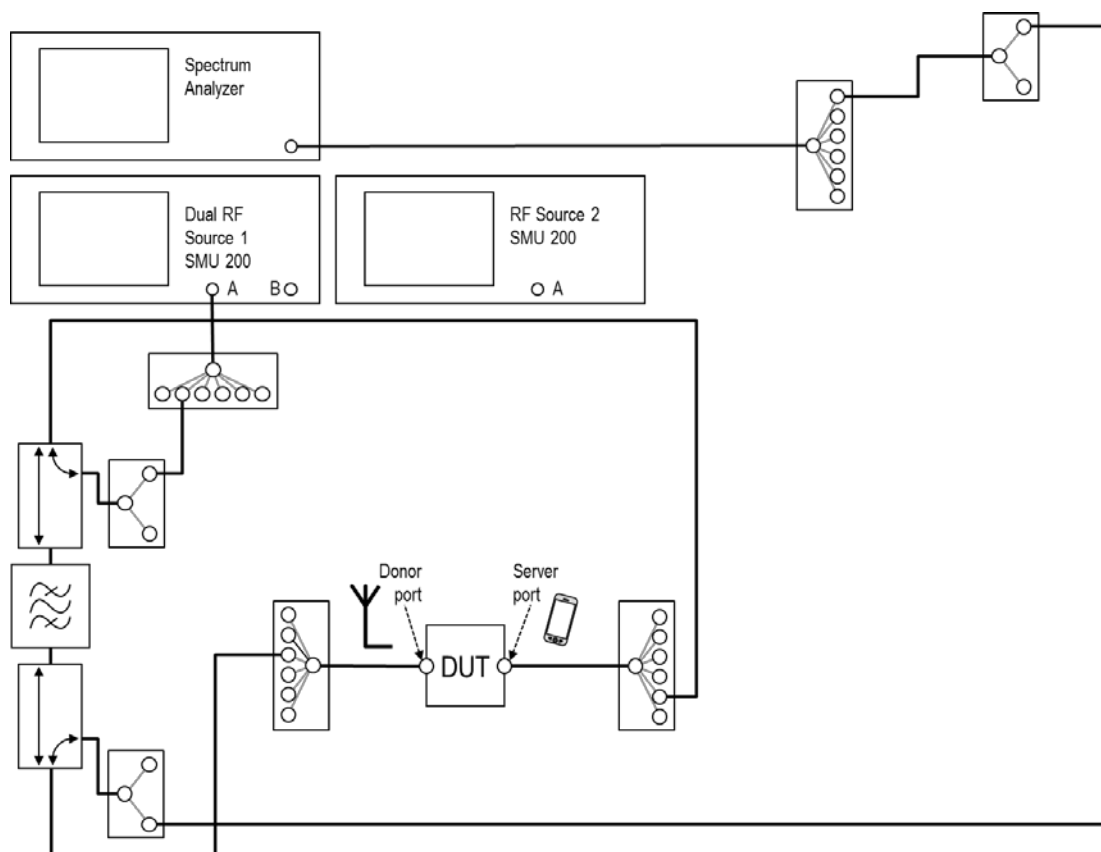

Fig. 279: Set up for oscillation detection and mitigation tests in uplink.

Note: For this special type of booster under test a stimulating signal is required at the server port to switch the uplink amplifier ON to be able to measure test 5.11.1 oscillation restart (KDB Test Case 7.11.2)

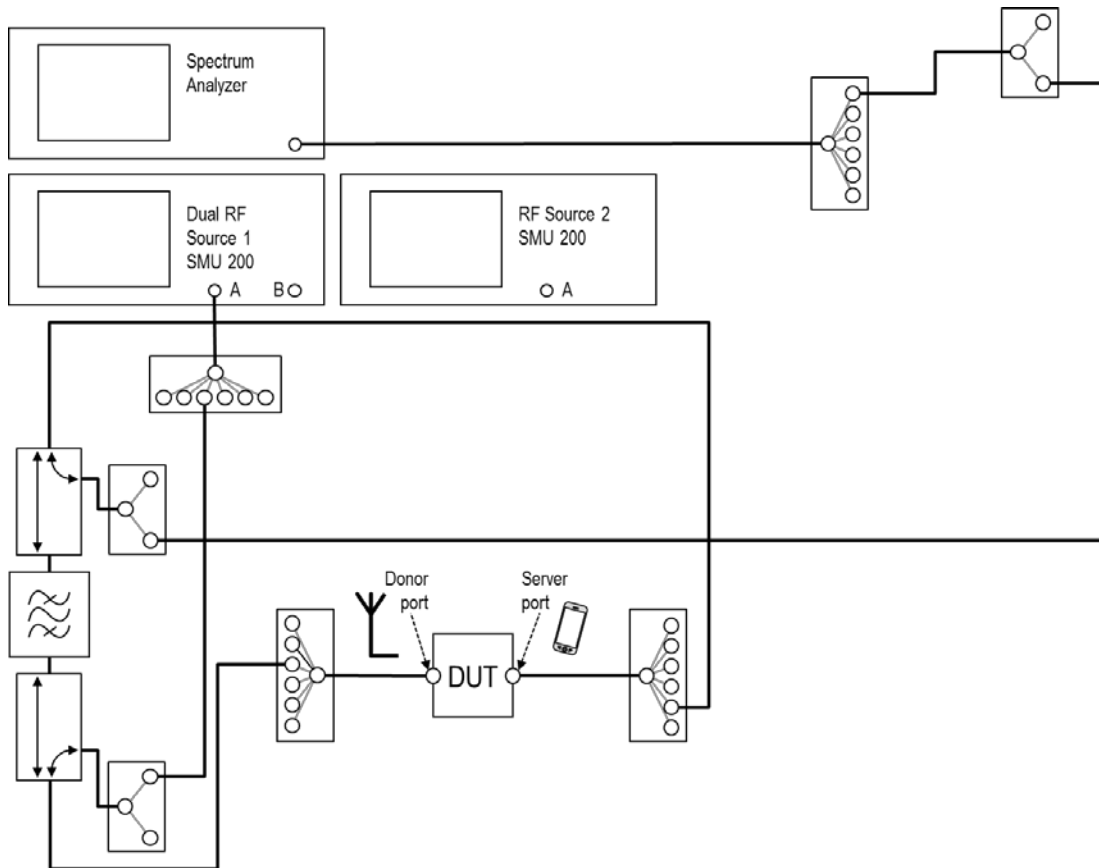

Fig. 280: Set up for oscillation detection and mitigation tests in downlink.

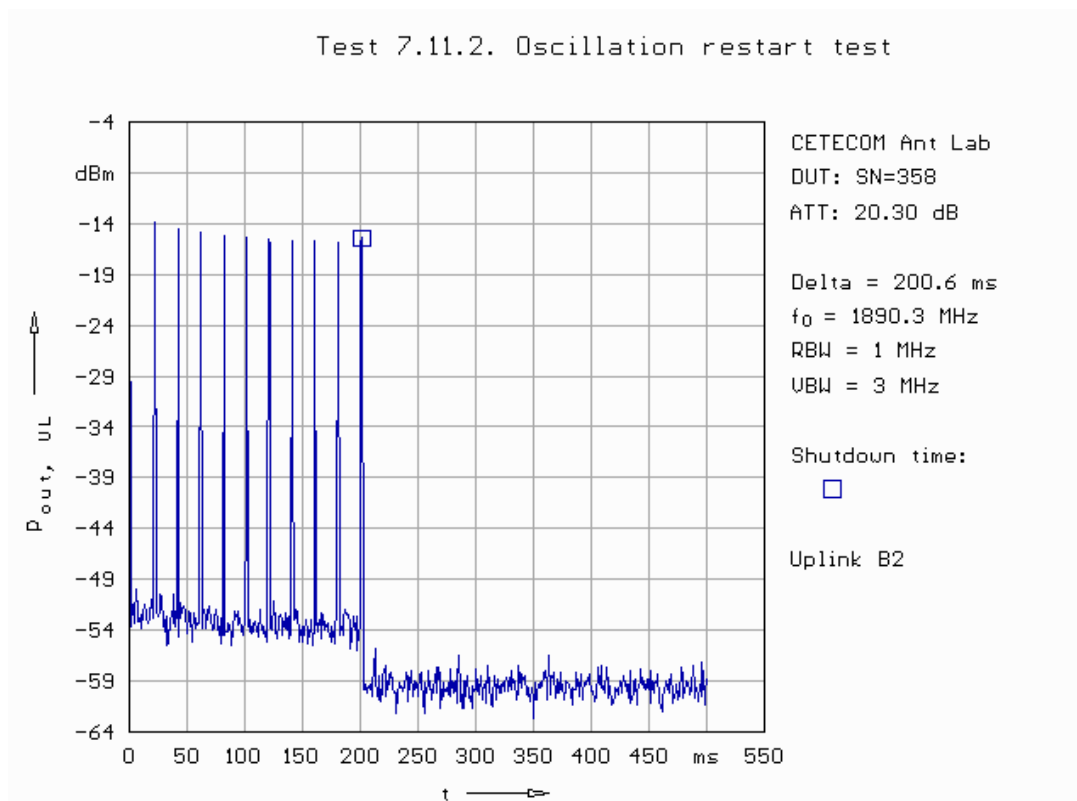

Fig. 281: Band 2 uplink oscillation detection time test result.

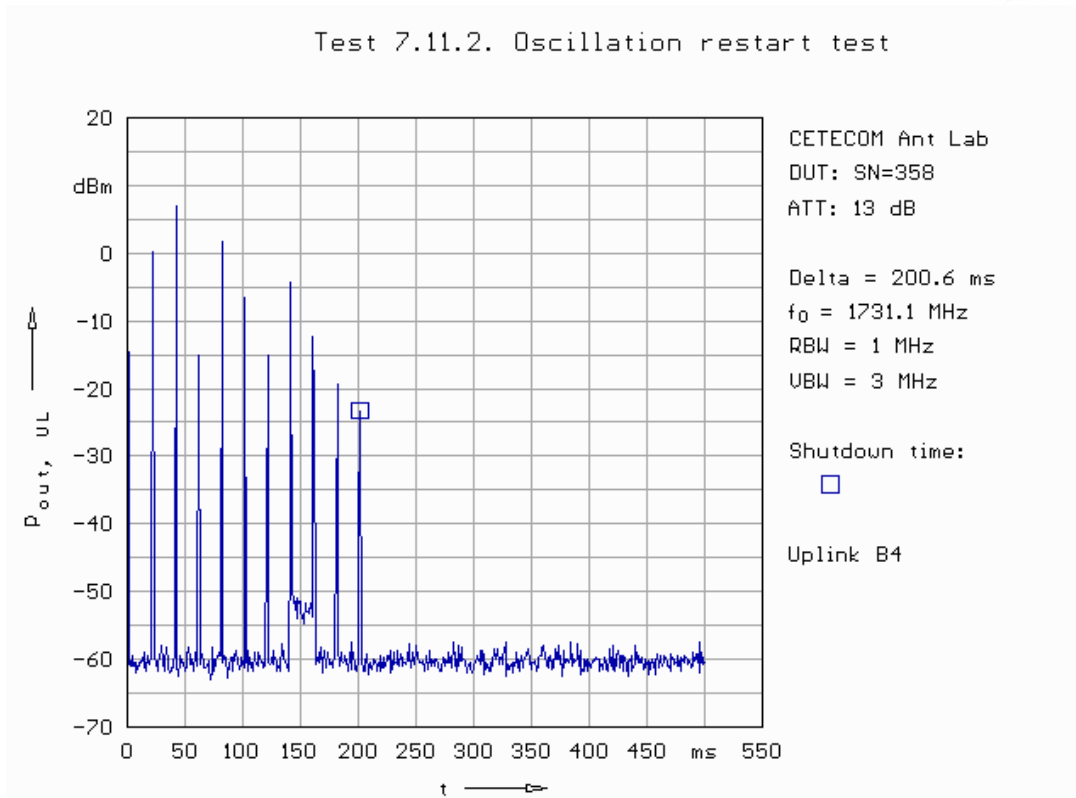

Fig. 282: Band 4 uplink oscillation detection time test result.

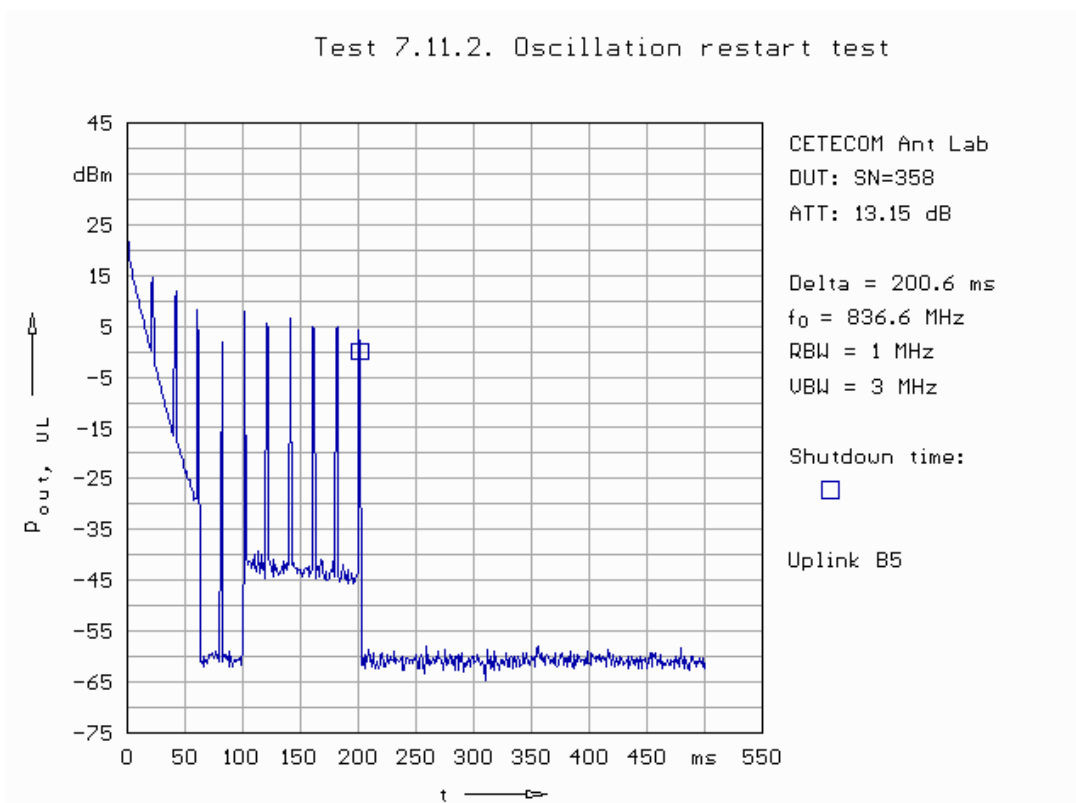

Fig. 283: Band 5 uplink oscillation detection time test result.

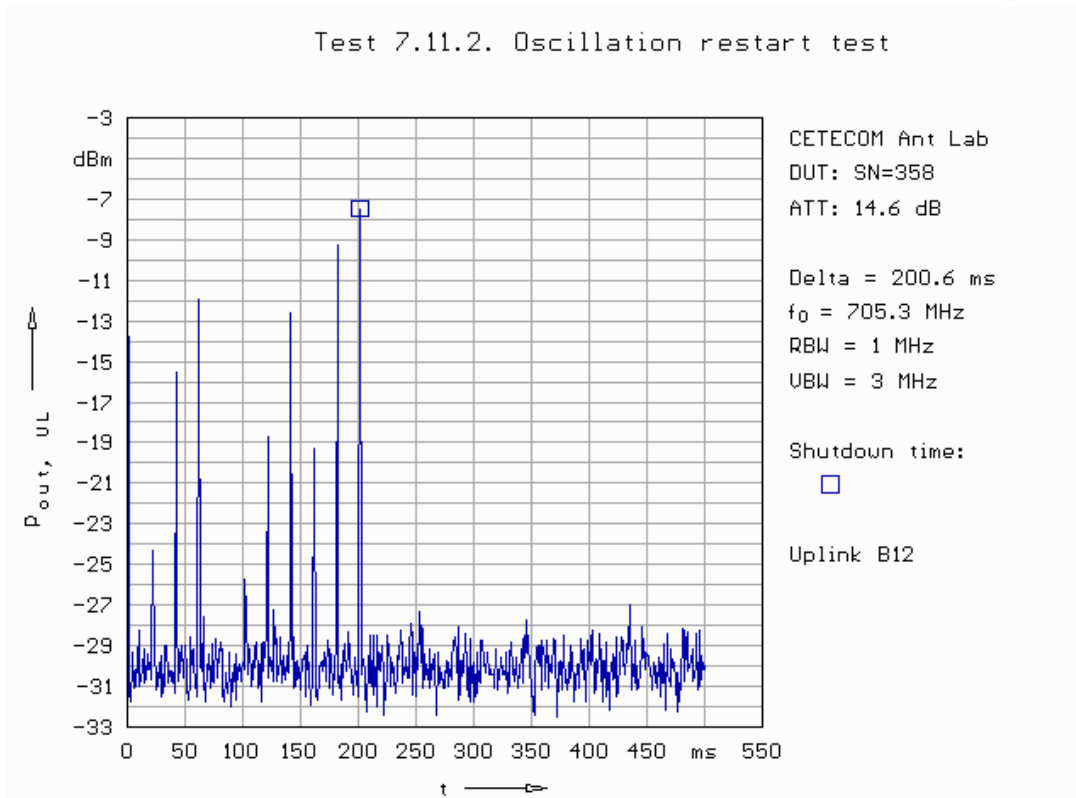

Fig. 284: Band 12 uplink oscillation detection time test result.

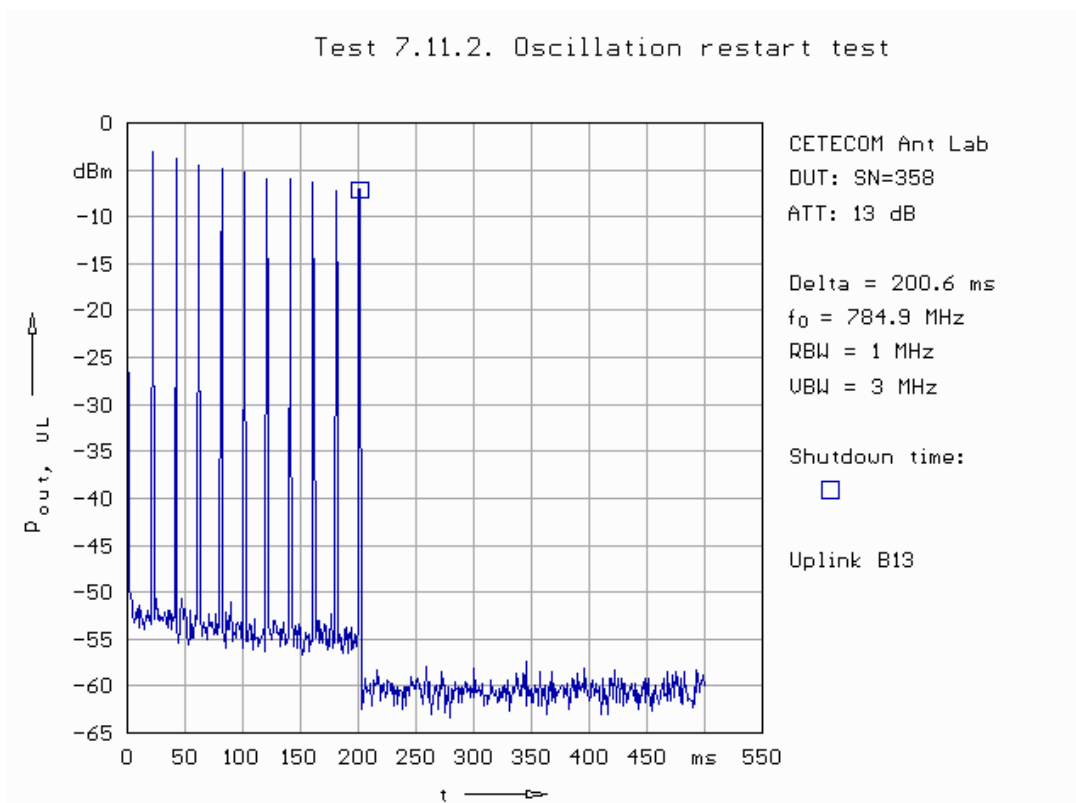

Fig. 285: Band 13 uplink oscillation detection time test result.

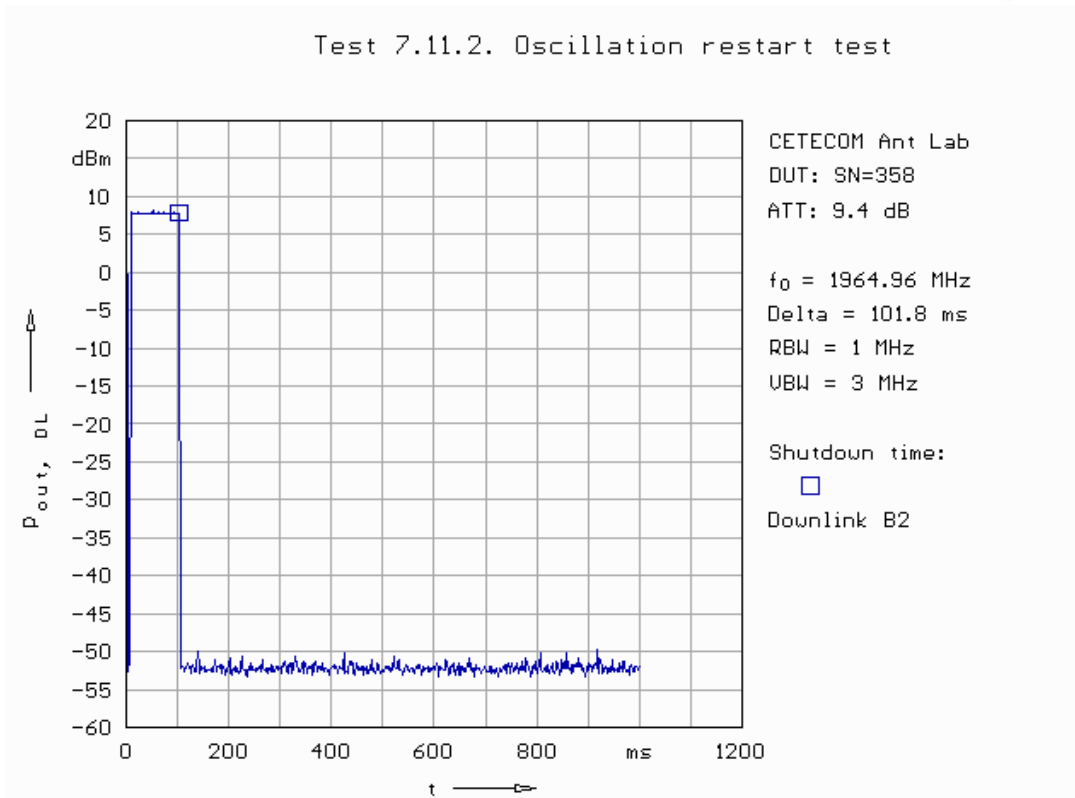

Fig. 286: Band 2 downlink oscillation detection time test result.

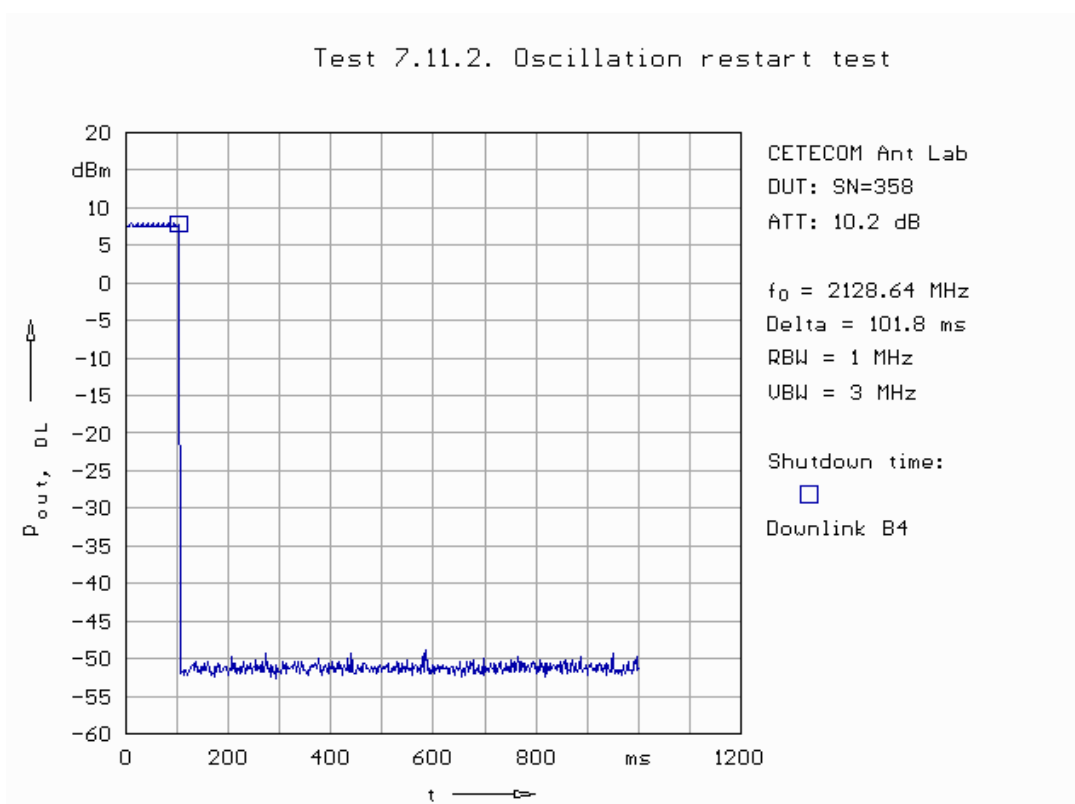

Fig. 287: Band 4 downlink oscillation detection time test result.

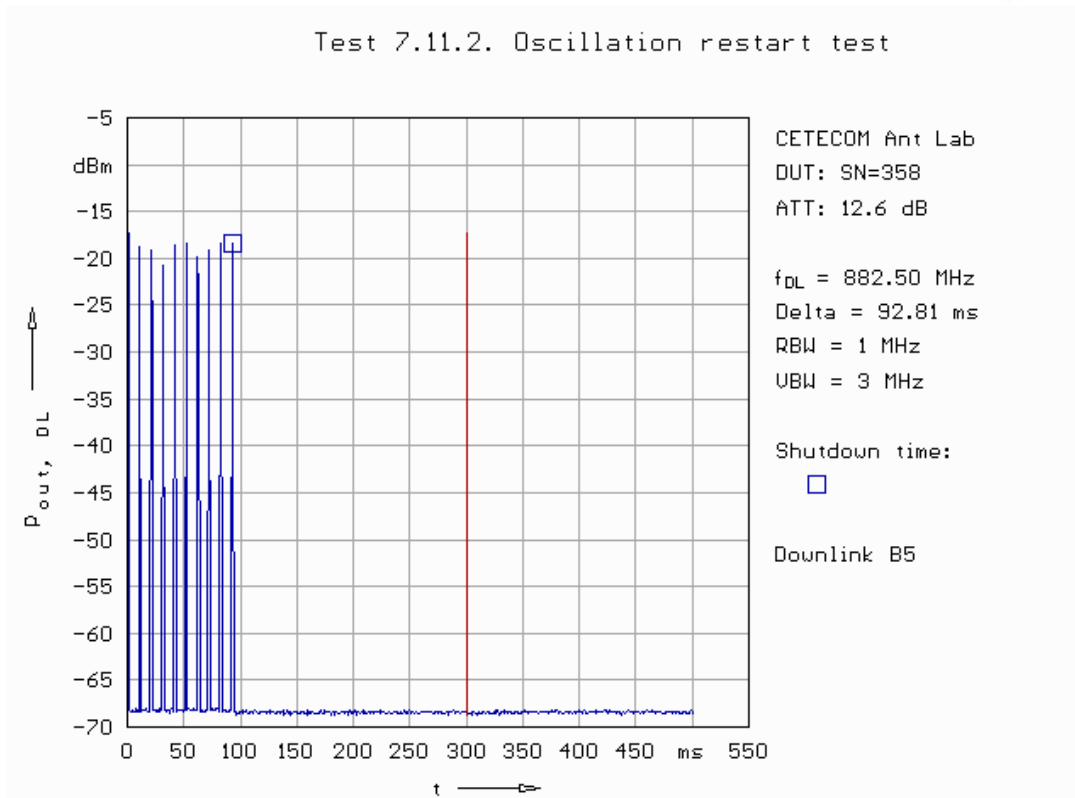

Fig. 288: Band 5 downlink oscillation detection time test result.

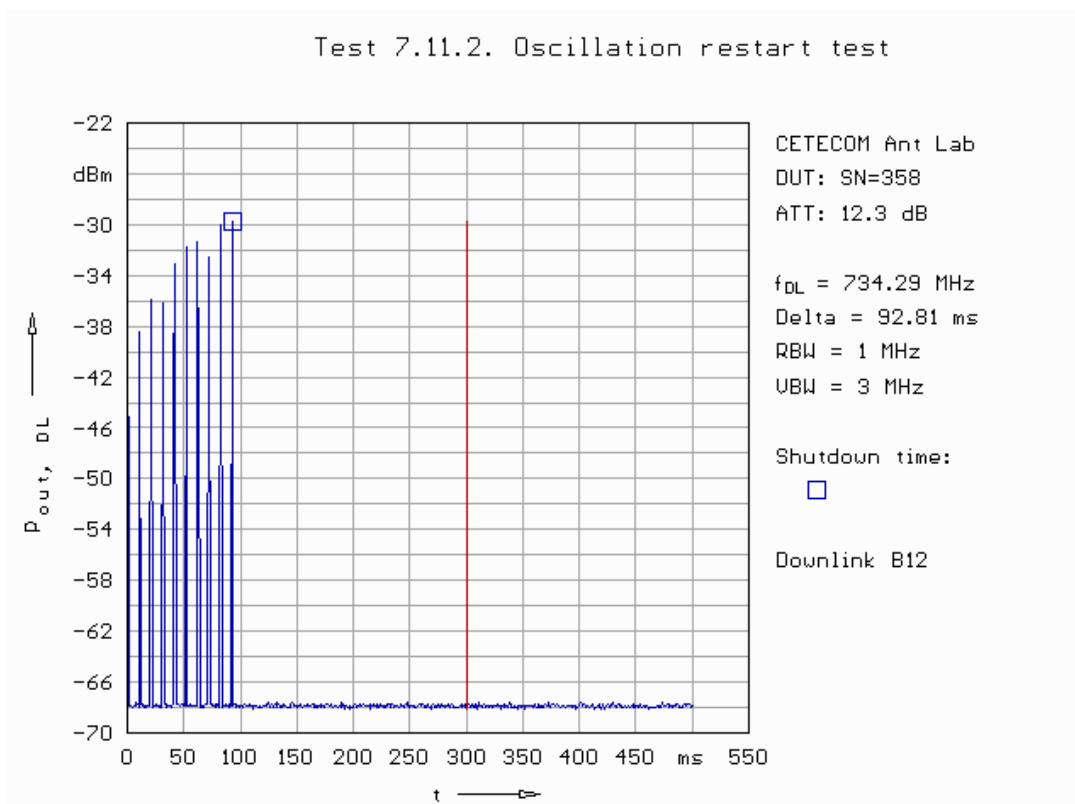

Fig. 289: Band 12 downlink oscillation detection time test result.

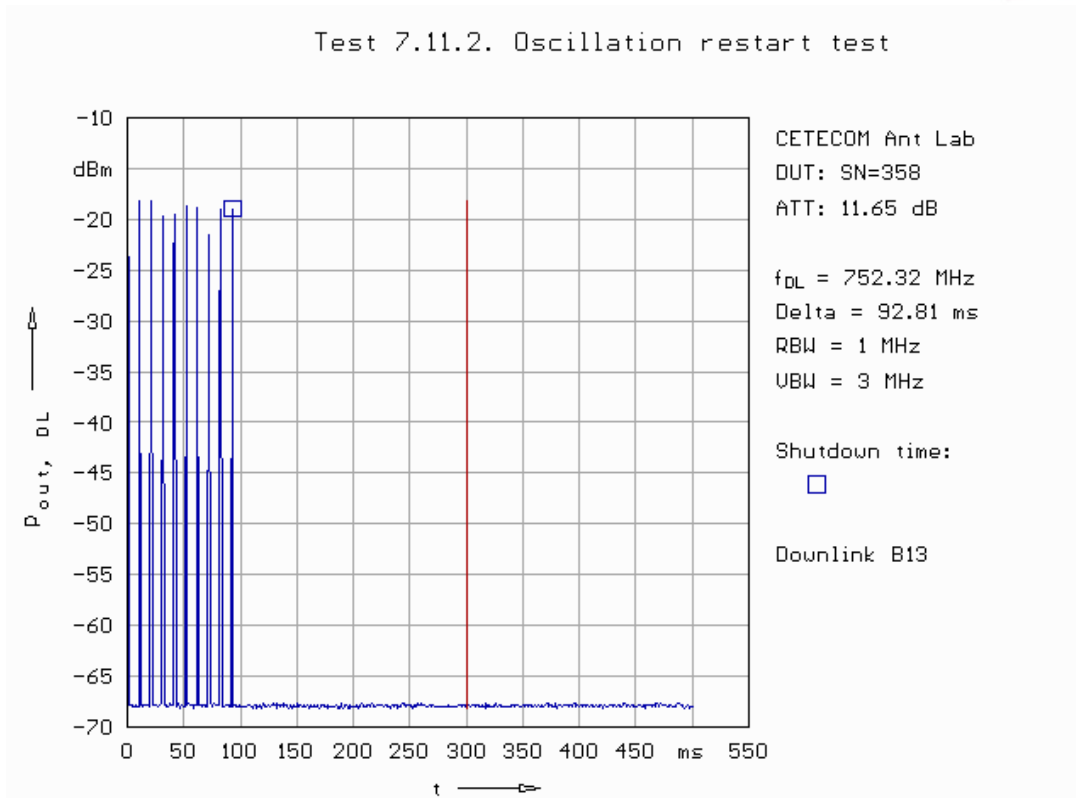

Fig. 290: Band 13 downlink oscillation detection time test result.

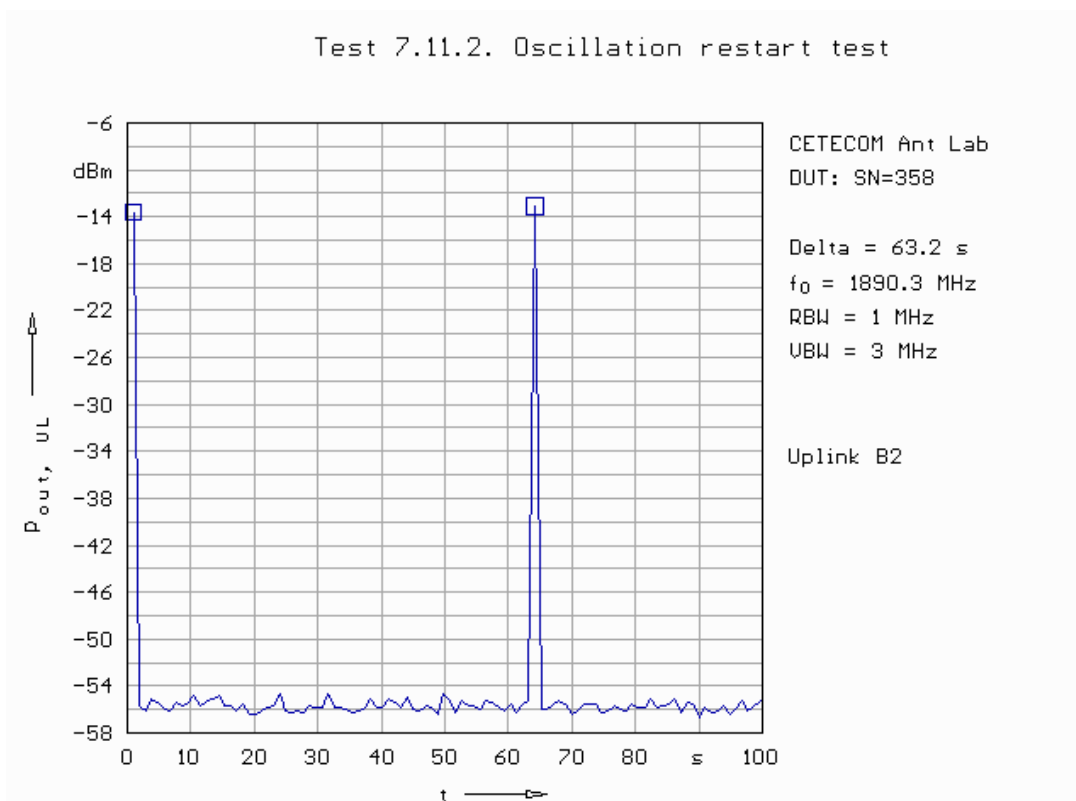

Fig. 291: Band 2 uplink restart time test result.

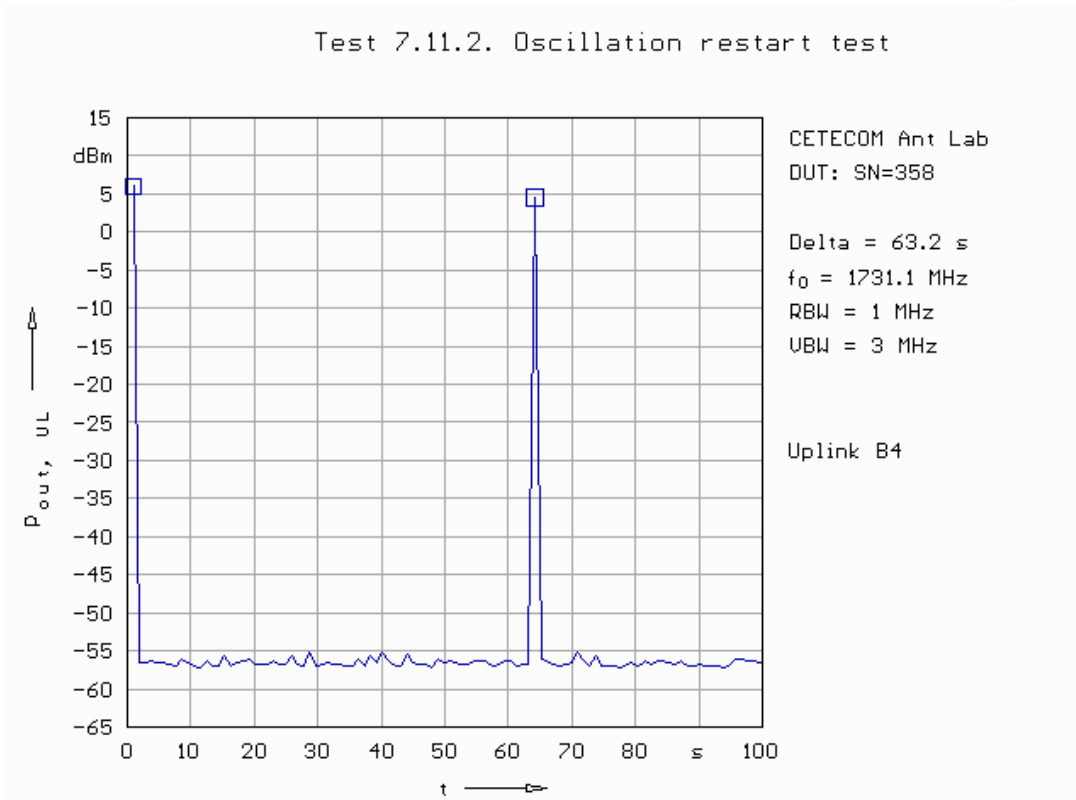

Fig. 292: Band 4 uplink restart time test result.

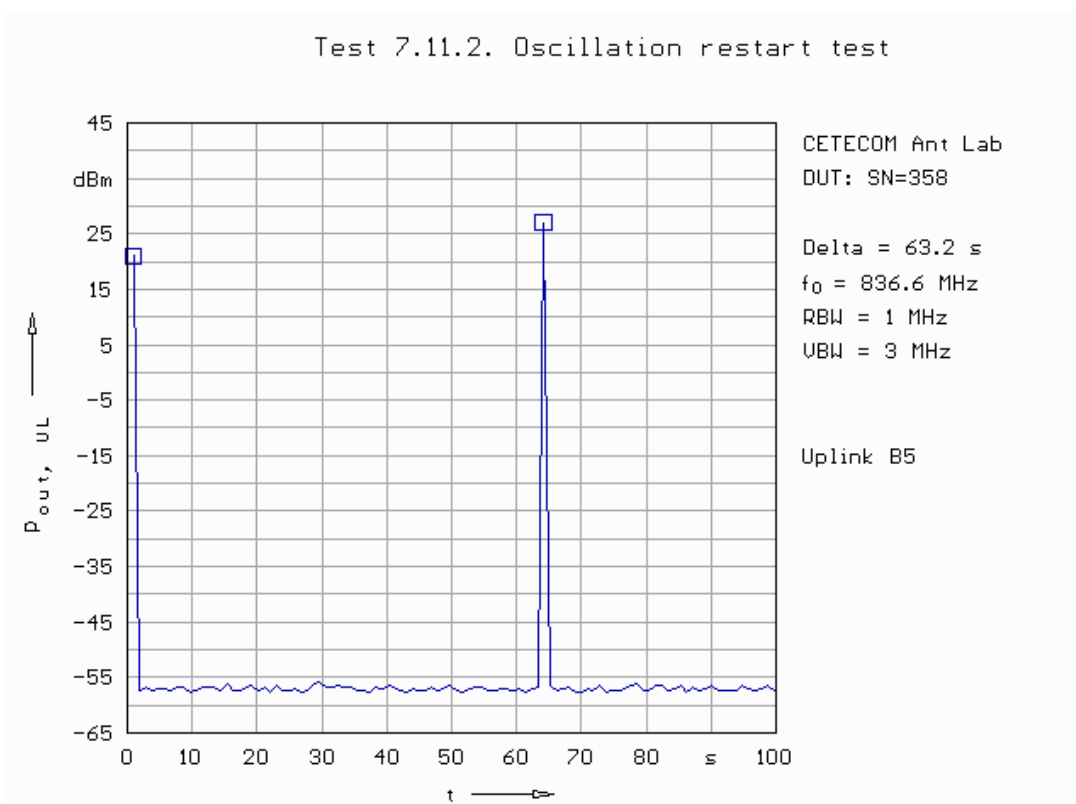

Fig. 293: Band 5 uplink restart time test result.

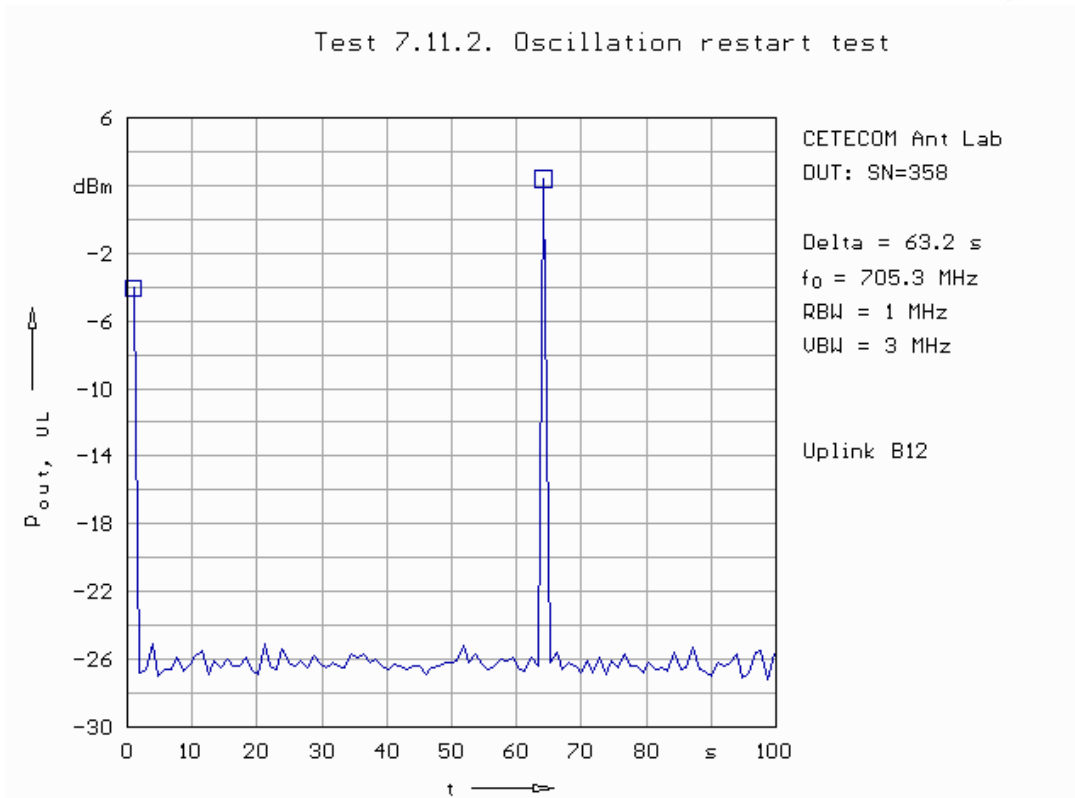

Fig. 294: Band 12 uplink restart time test result.

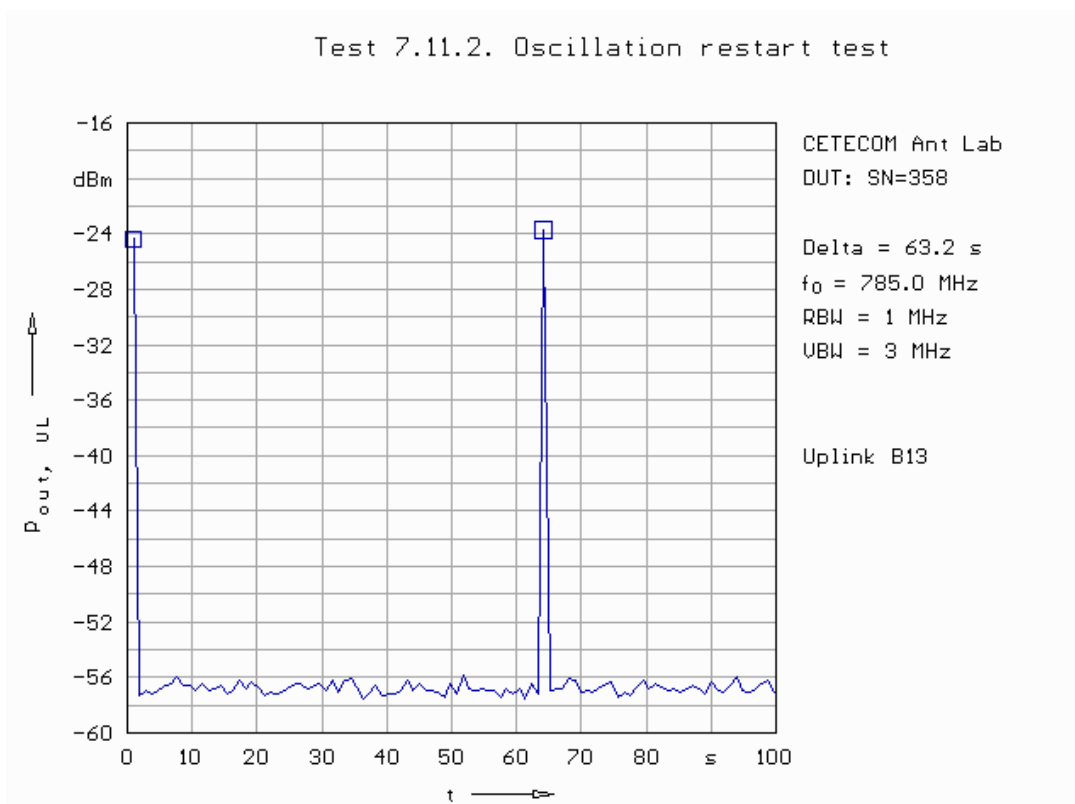

Fig. 295: Band 13 uplink restart time test result.

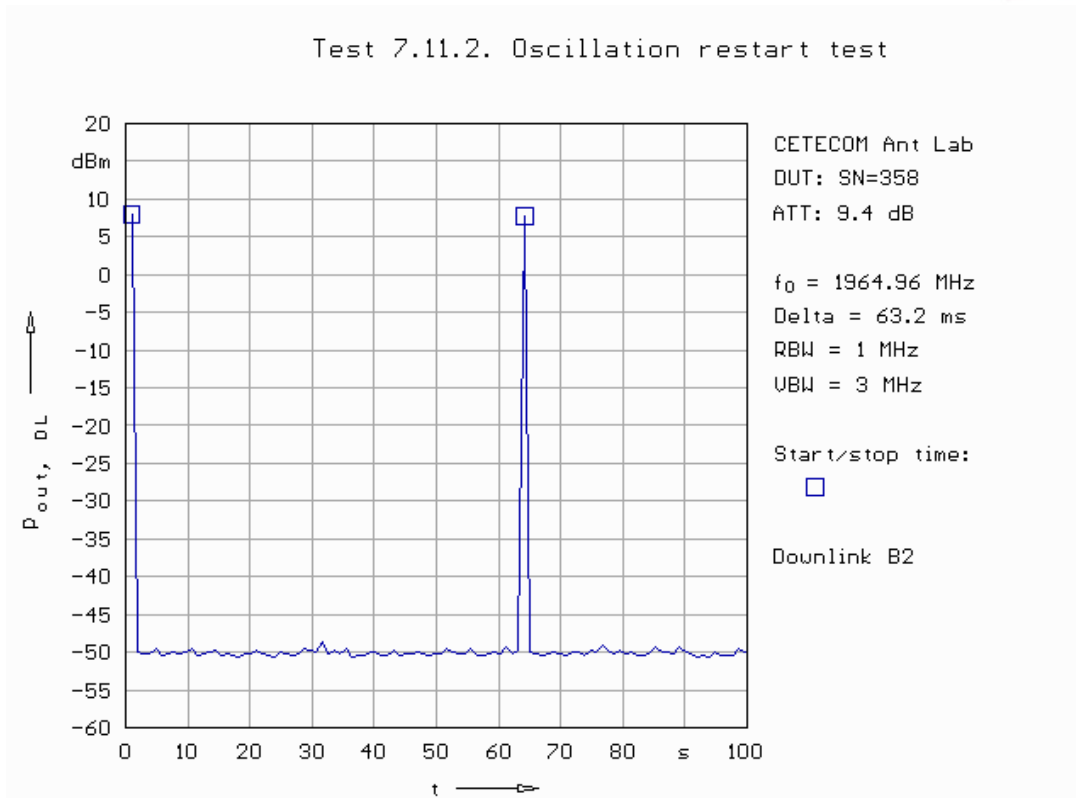

Fig. 296: Band 2 downlink restart time test result.

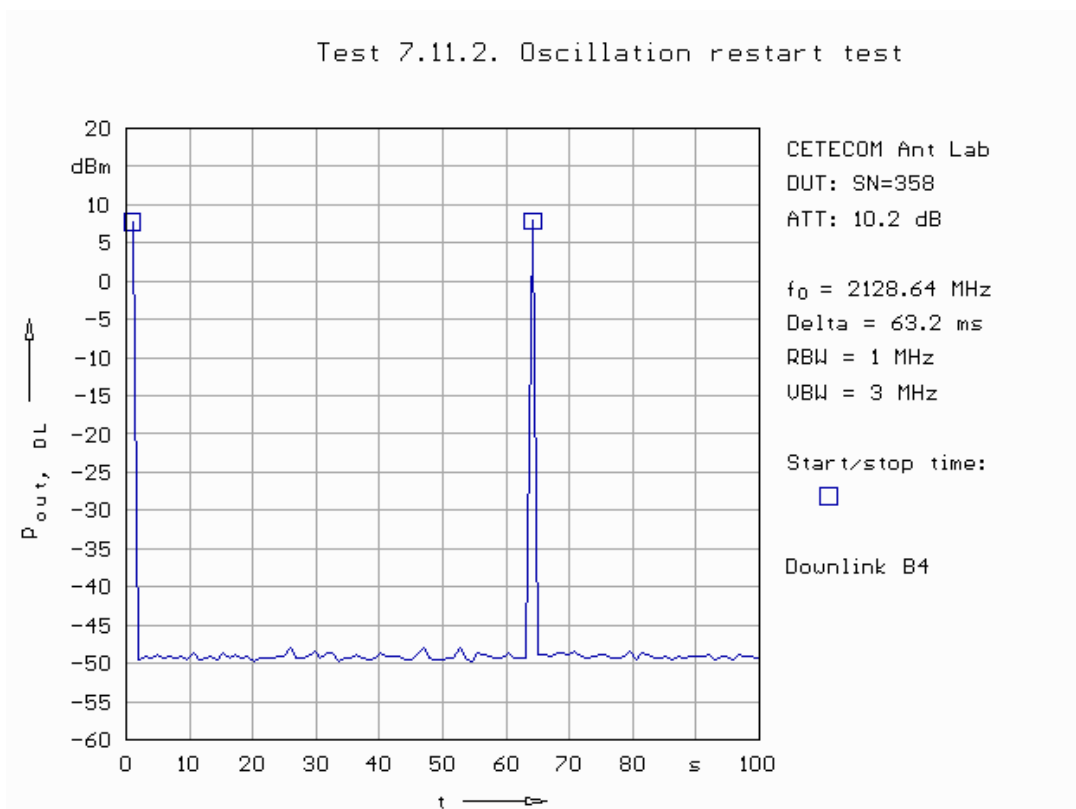

Fig. 297: Band 4 downlink restart time test result.

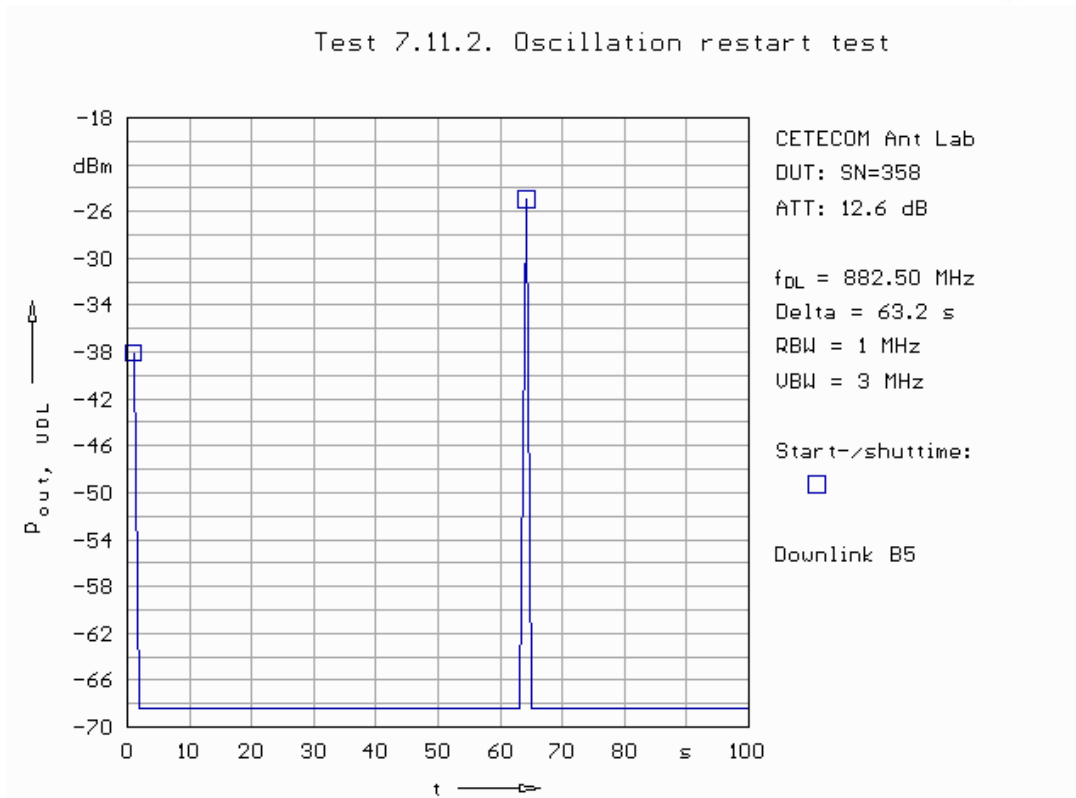

Fig. 298: Band 5 downlink restart time test result.

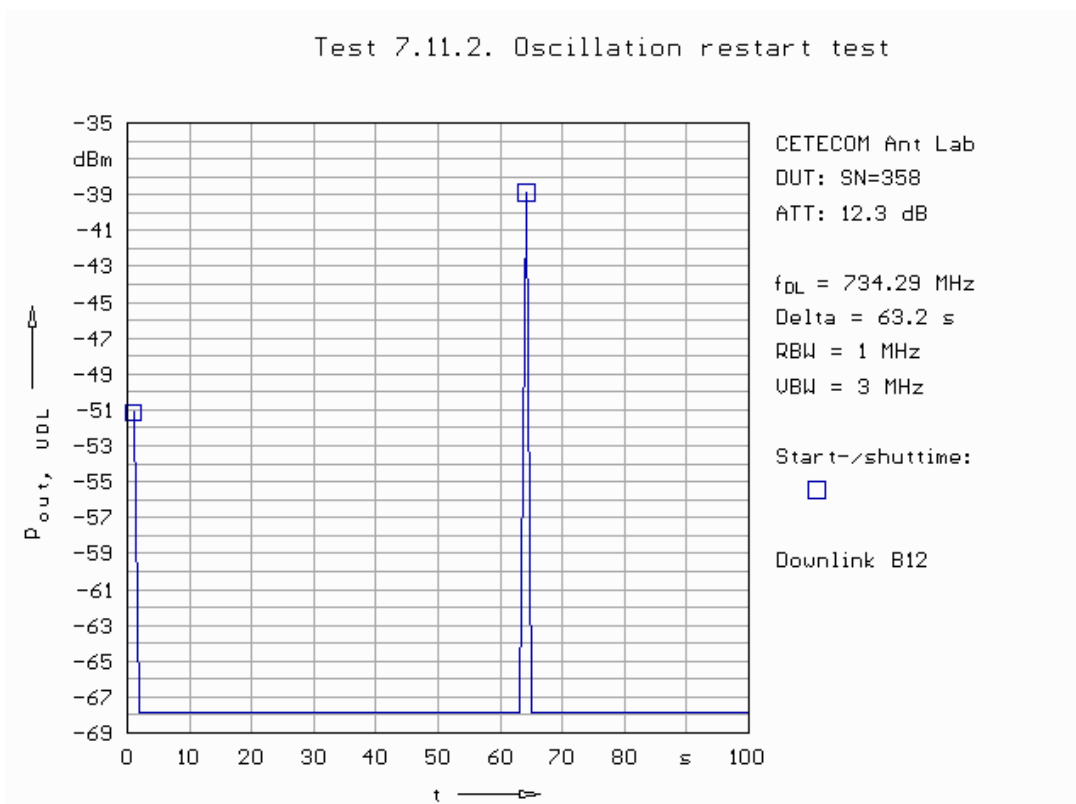

Fig. 299: Band 12 downlink restart time test result.

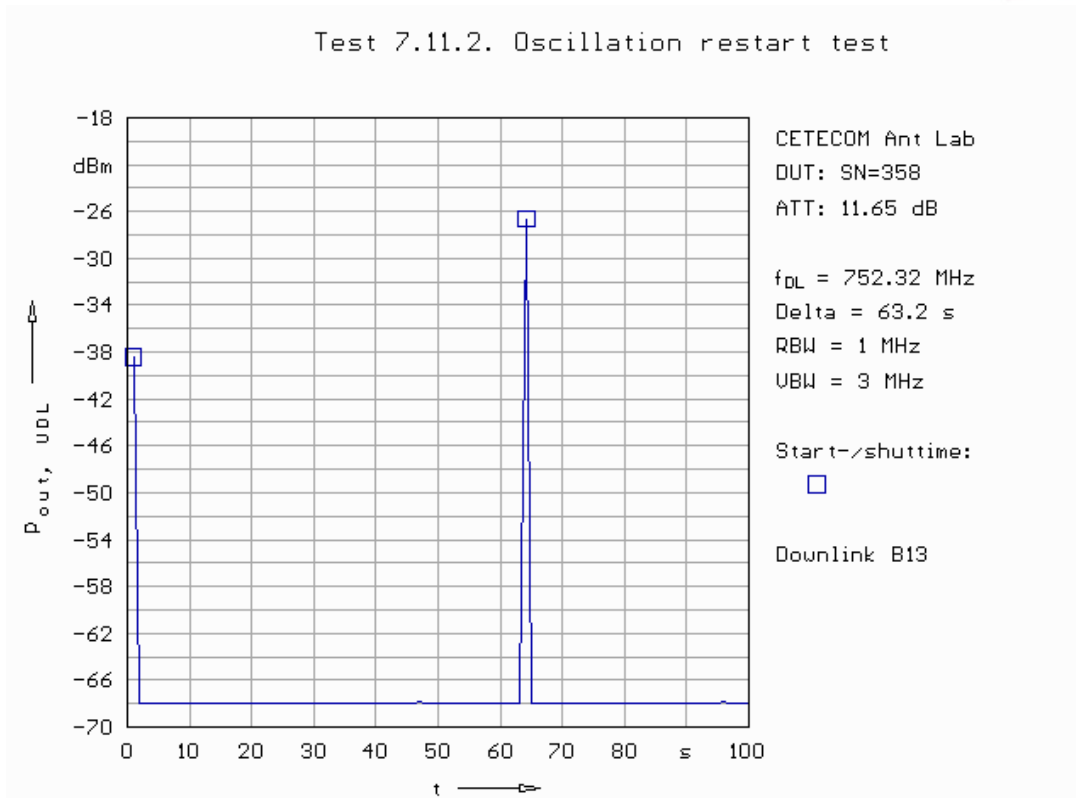

Fig. 300: Band 13 downlink restart time test result.

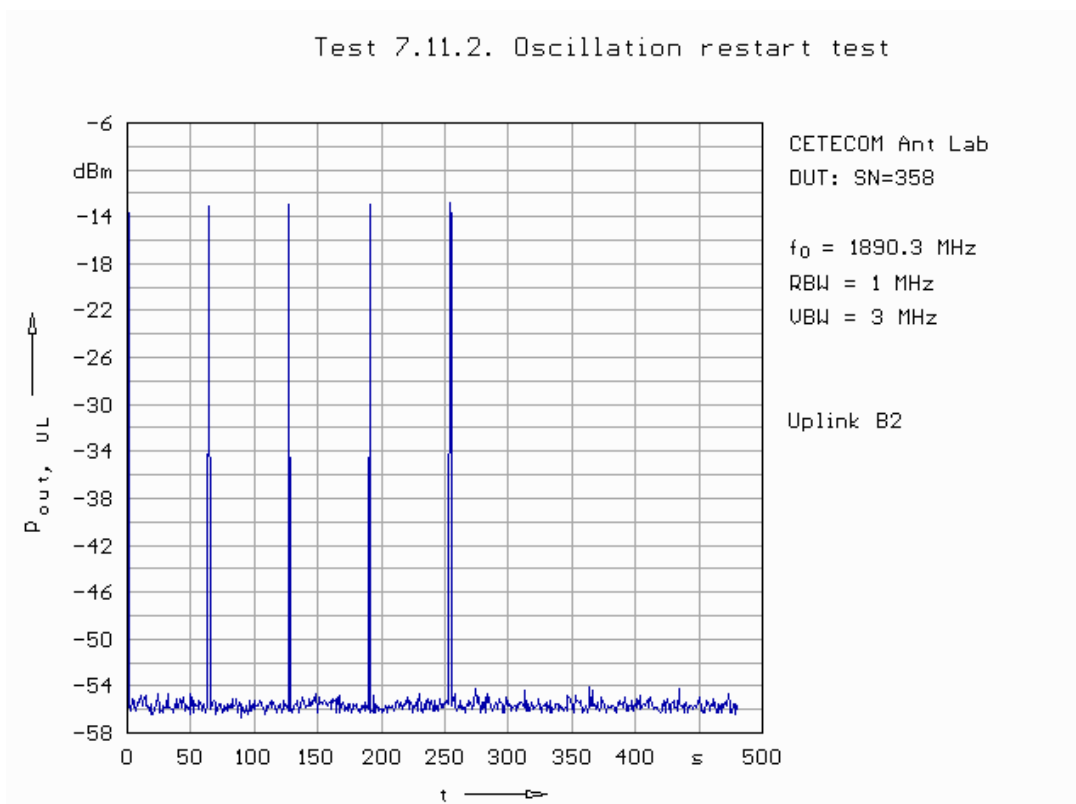

Fig. 301: Band 2 uplink restart attempt test result.

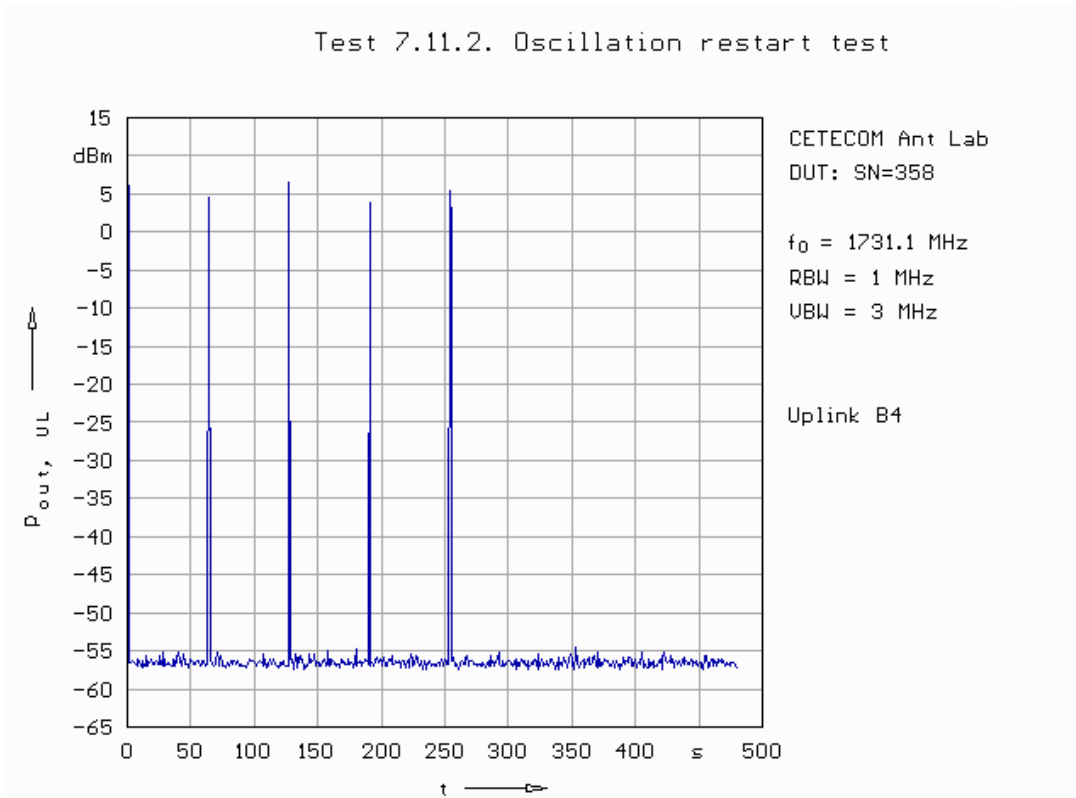

Fig. 302: Band 4 uplink restart attempt test result.

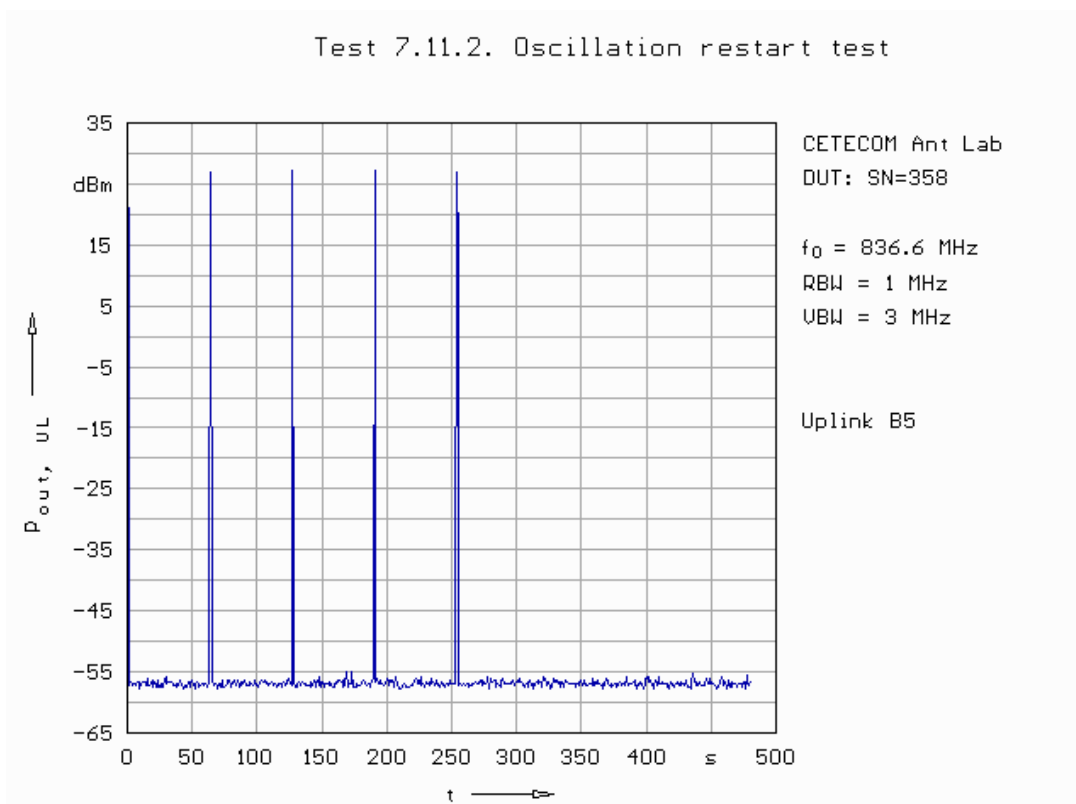

Fig. 303: Band 5 uplink restart attempt test result.

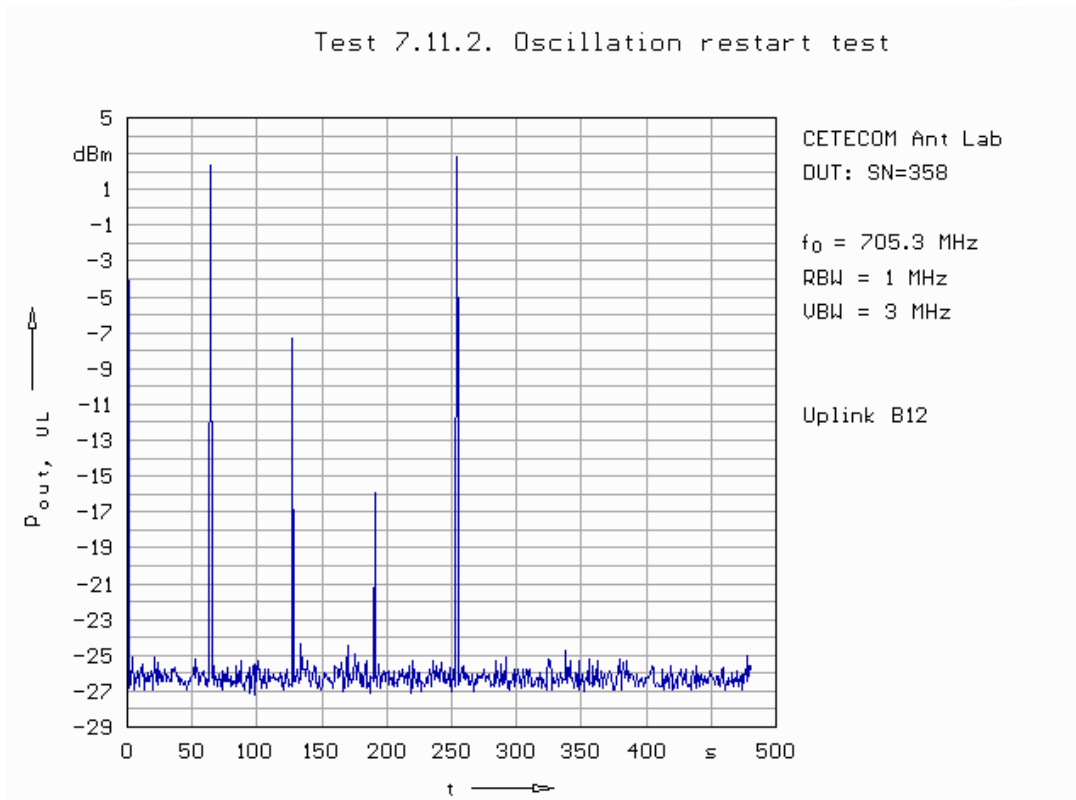

Fig. 304: Band 12 uplink restart attempt test result.

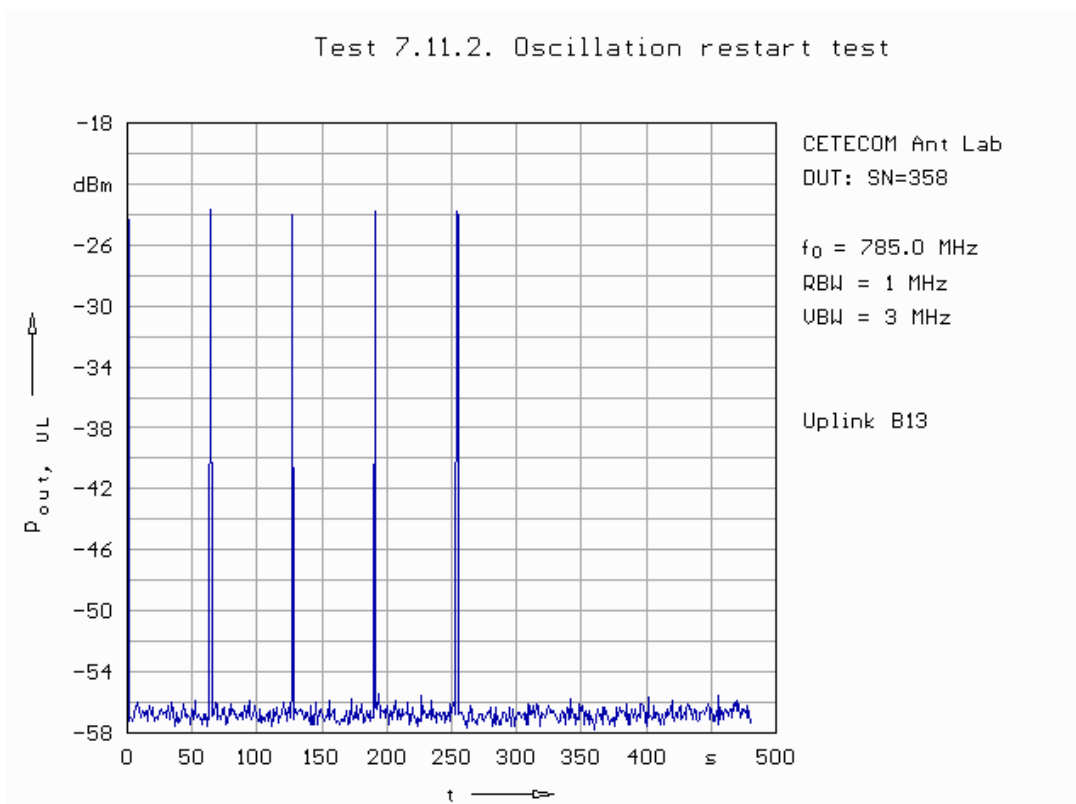

Fig. 305: Band 13 uplink restart attempt test result.

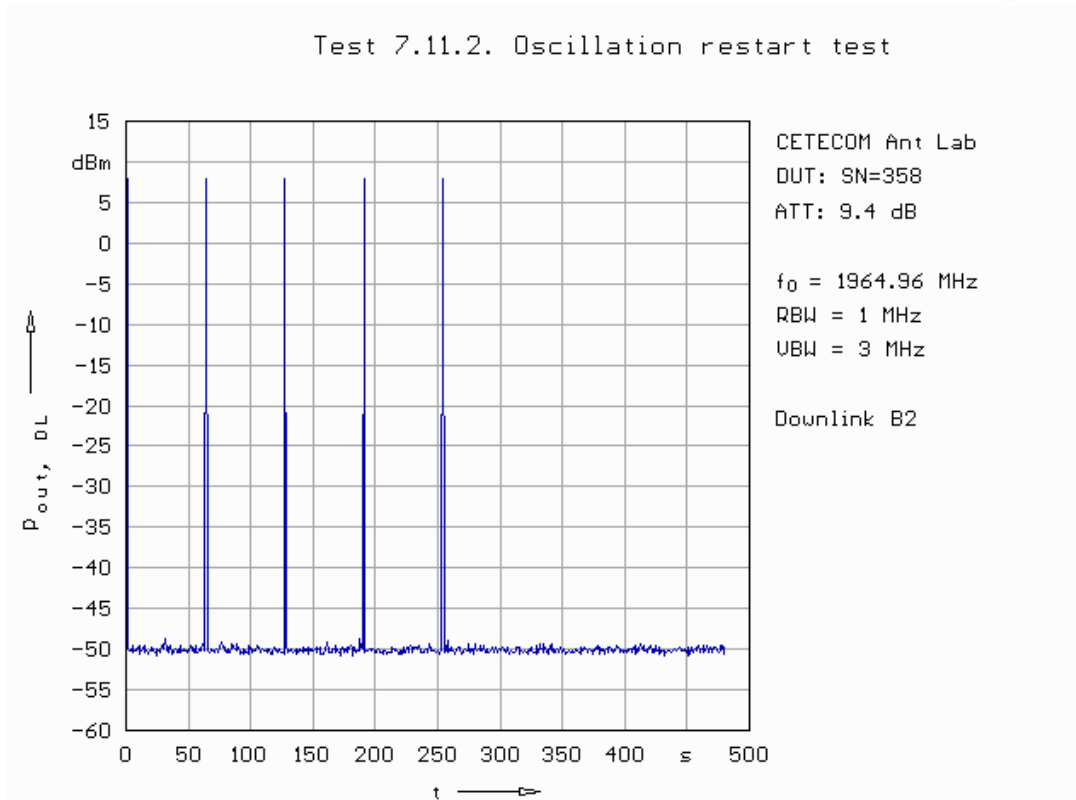

Fig. 306: Band 2 downlink restart attempt test result.

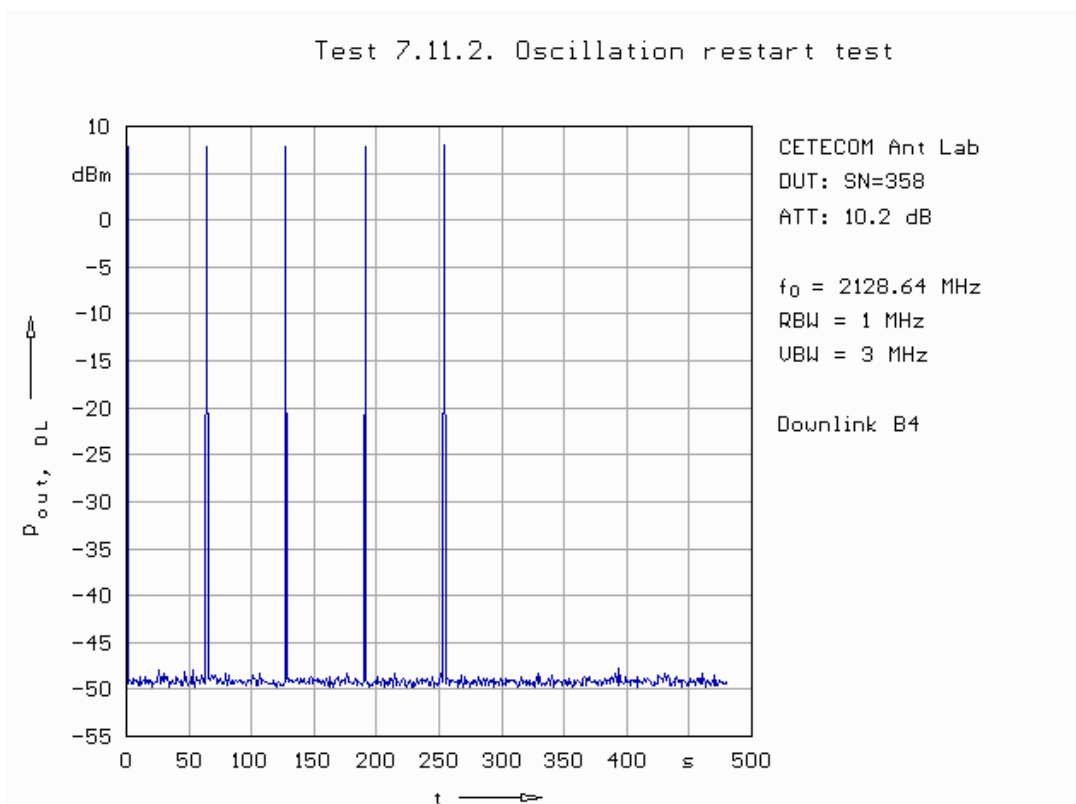

Fig. 307: Band 4 downlink restart attempt test result.

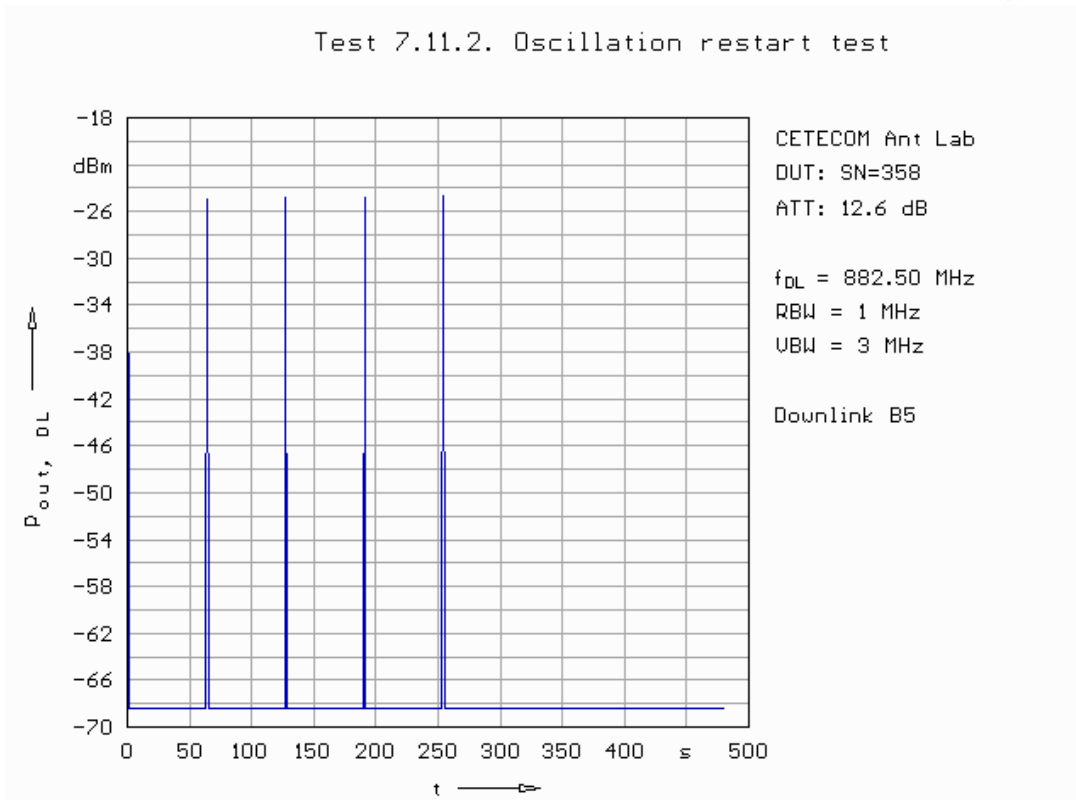

Fig. 308: Band 5 downlink restart attempt test result.

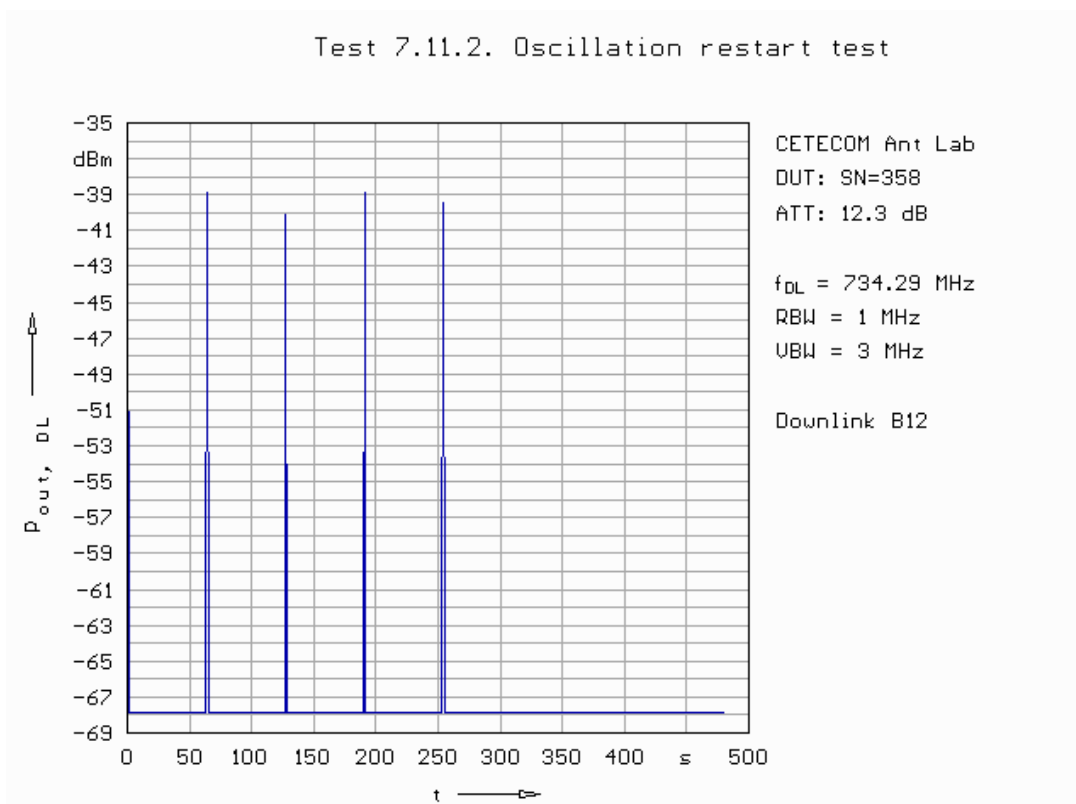

Fig. 309: Band 12 downlink restart attempt test result.

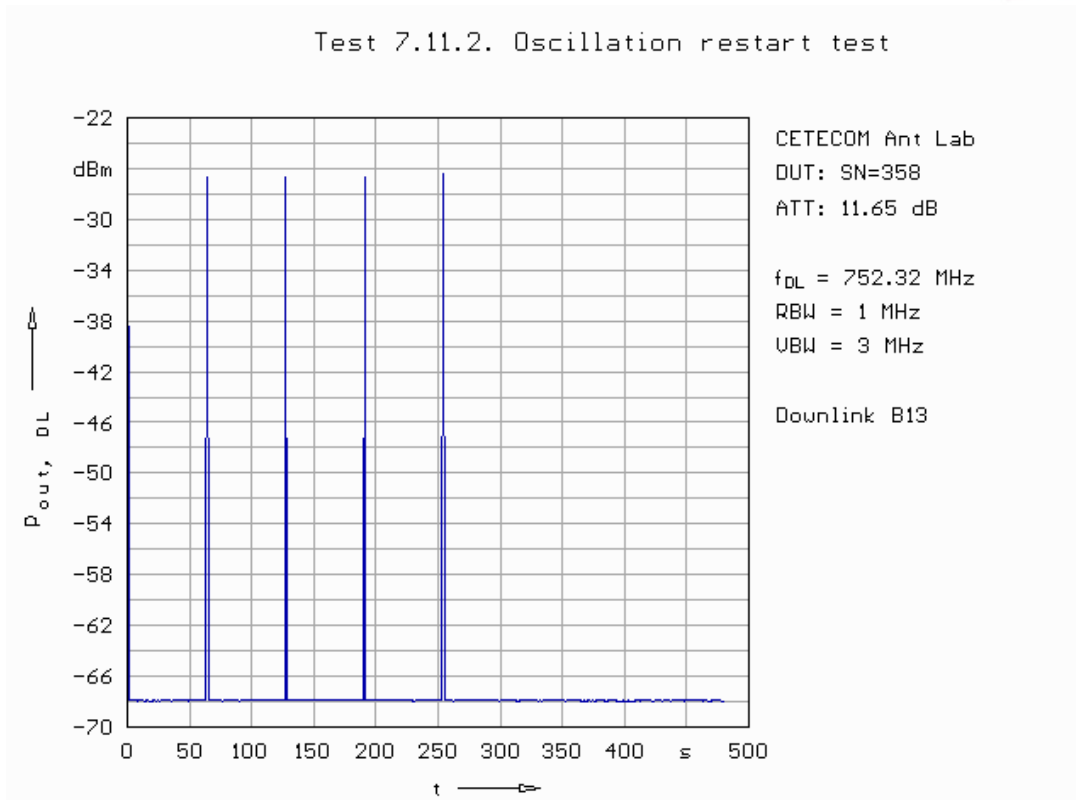

Fig. 310: Band 13 downlink restart attempt test result.

5.11.2 Test Procedure for Measuring Oscillation Mitigation or Shutdown

For measuring the capability of this special type of booster under test to shut down to mitigate the oscillations we have conducted measurements as described in the specification:

- That the booster shut down to mitigate the oscillation and
- also the maximum of oscillation as described in KDB 935210 D03 to ensure that the maximum output level of the oscillation does not exceed the minimal output level by 12 dB before the booster shut down.

The test setup as shown in Fig. 279 and Fig. 280 has been used. All test has been done in 1 dB steps as required. Below are summarized the measured results for uplink and downlink oscillation mitigation in terms of maximum oscillation levels found. Note: In some bands and some attenuation steps an immediate shutdown occurred (e.g. band 2: 5 dB over maximum gain).

Band	direction	Max Oscillation Power and frequency	Min Power within the span and frequency	Δ level /dBm	Δ level limit /dBm
2	up	-79.6 dBm/1889.2 MHz	-82.4 dBm /1902.6 MHz	2.8	12
4	up	-73.1 dBm/1743.5 MHz	-83.9 dBm/1748.84 MHz	10.8	12
5	up	-74.3 dBm/836.47 MHz	-84.1 dBm/832.84 MHz	9.8	12
12	up	-76.5 dBm/705.28 MHz	-83.0 dBm/707.74 MHz	6.5	12
13	up	-76.2 dBm/784.95 MHz	-84.3 dBm/787.13 MHz	8.1	12
2	down	-74.6 dBm/1964.43 MHz	-84.1 dBm/1962.84 MHz	9.5	12
4	down	-71.6 dBm/2128.59 MHz	-82.0 dBm/2119.74 MHz	10.4	12
5	down	-83.9 dBm/887.01 MHz	-85.5 dBm/890.81 MHz	1.6	12
12	down	-83.1dBm/744.12 MHz	-84.6 dBm/749.99 MHz	1.5	12
13	down	-82.7 dBm/751.29 MHz	-84.8 dBm/748.84 MHz	2.1	12

Since in band 4 in uplink the overall maximum was found, details of the determination is reported below for this particular band and direction.

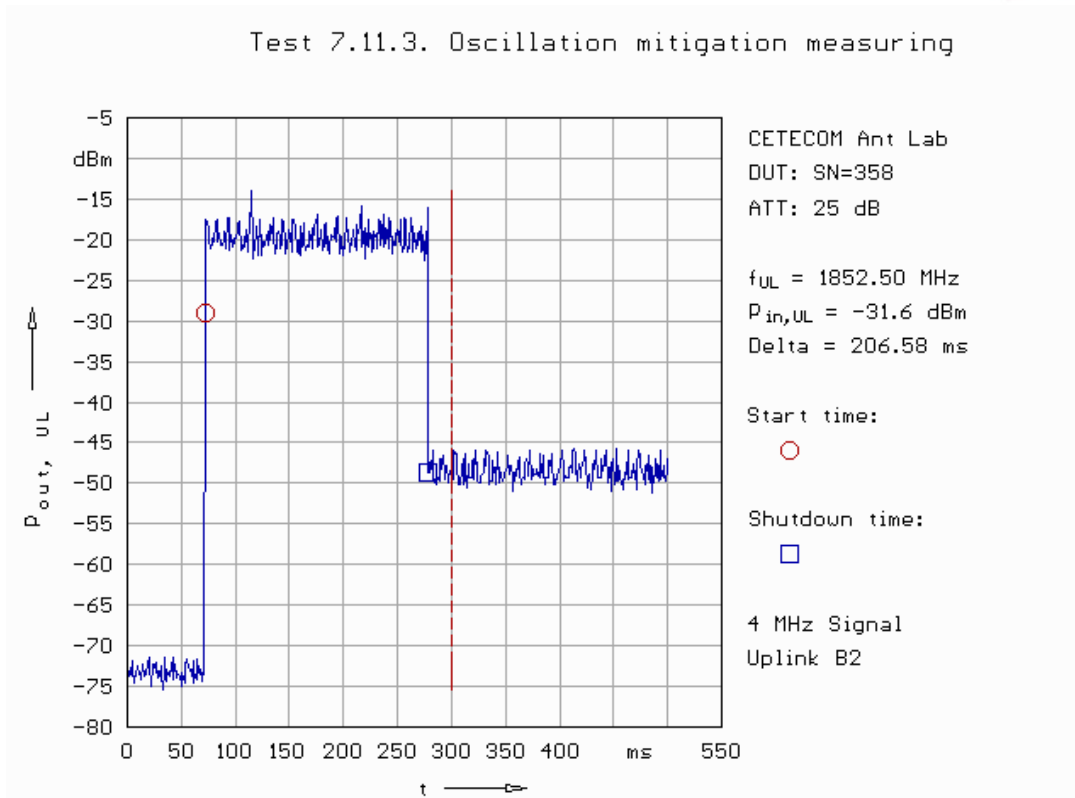

Fig. 311: Band 2 uplink shut down time.

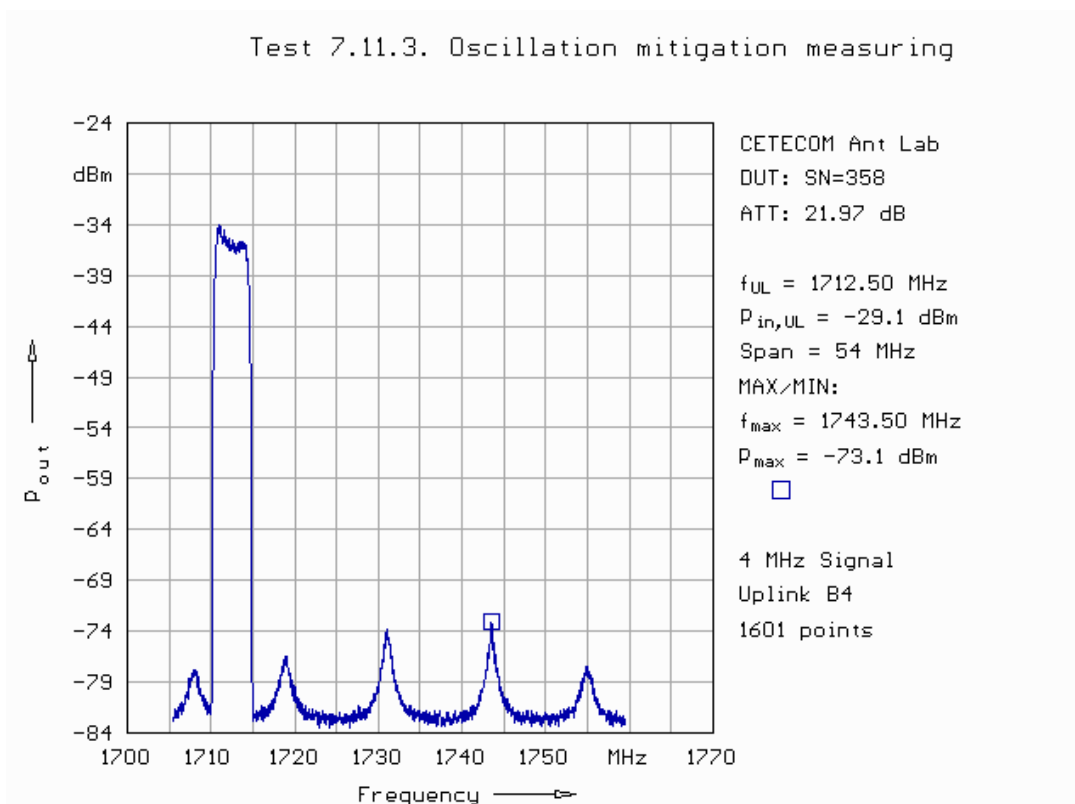

Fig. 312: Band 4 uplink maximum oscillation level.

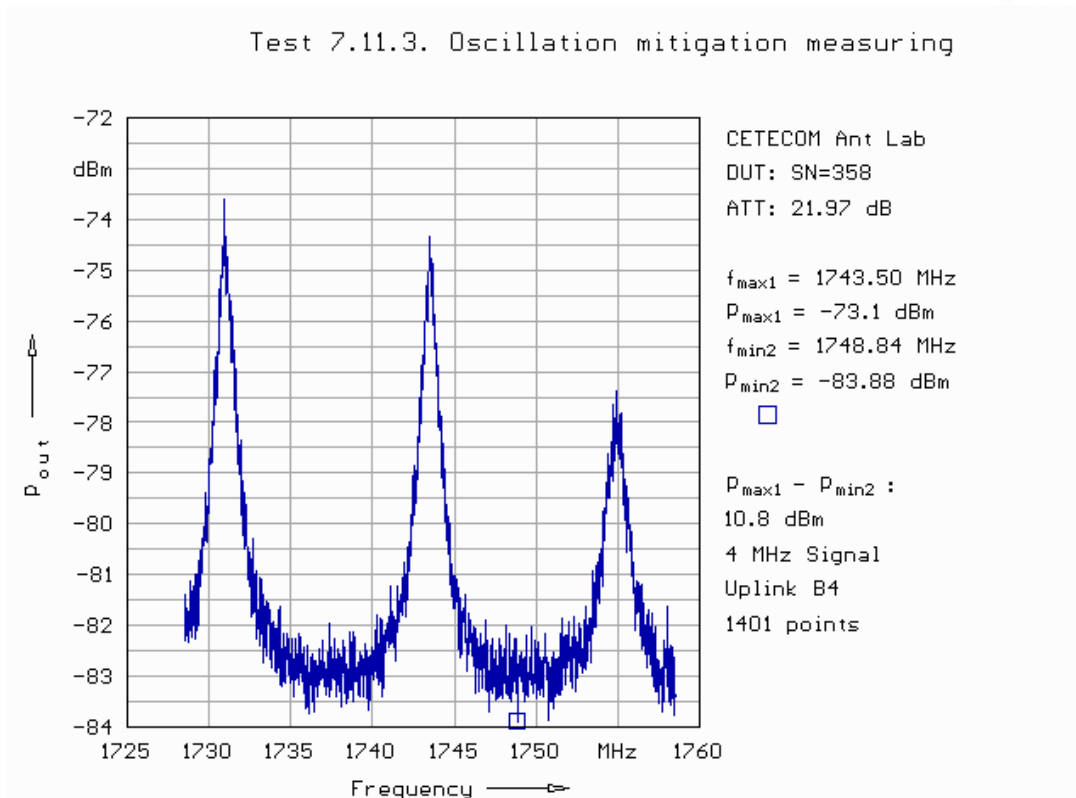

Fig. 313: Band 4 uplink maximum oscillation level determination.

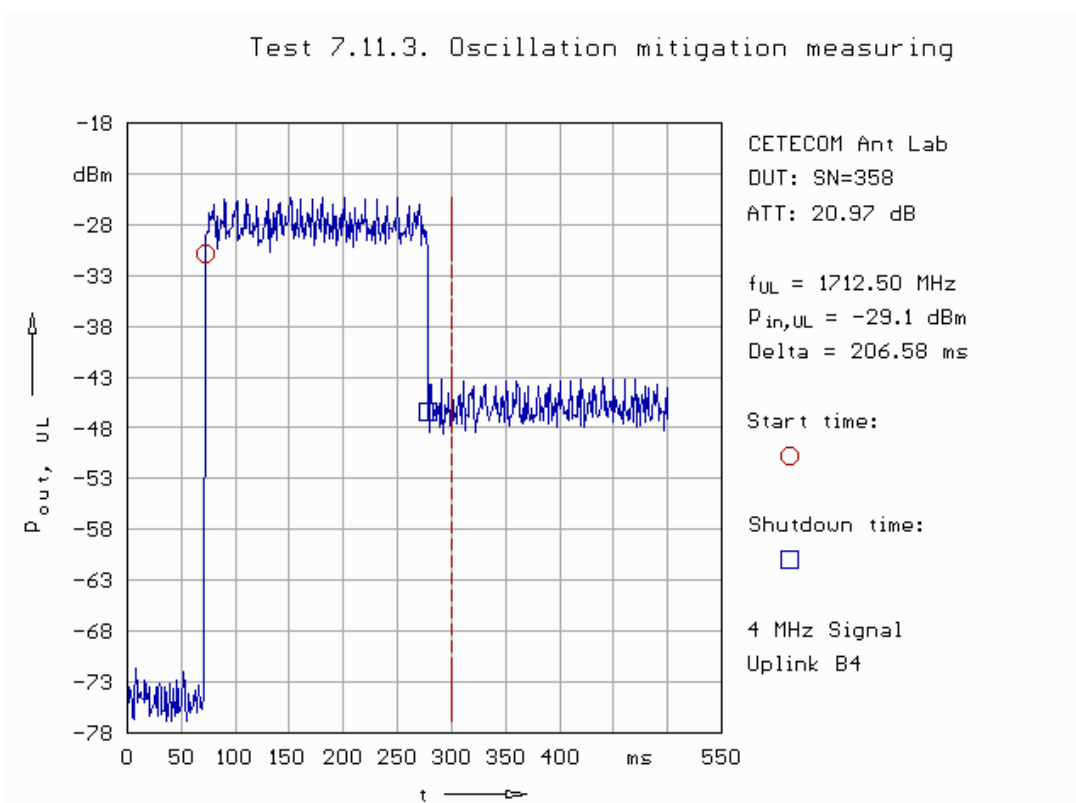

Fig. 314: Band 4 uplink shut down time.

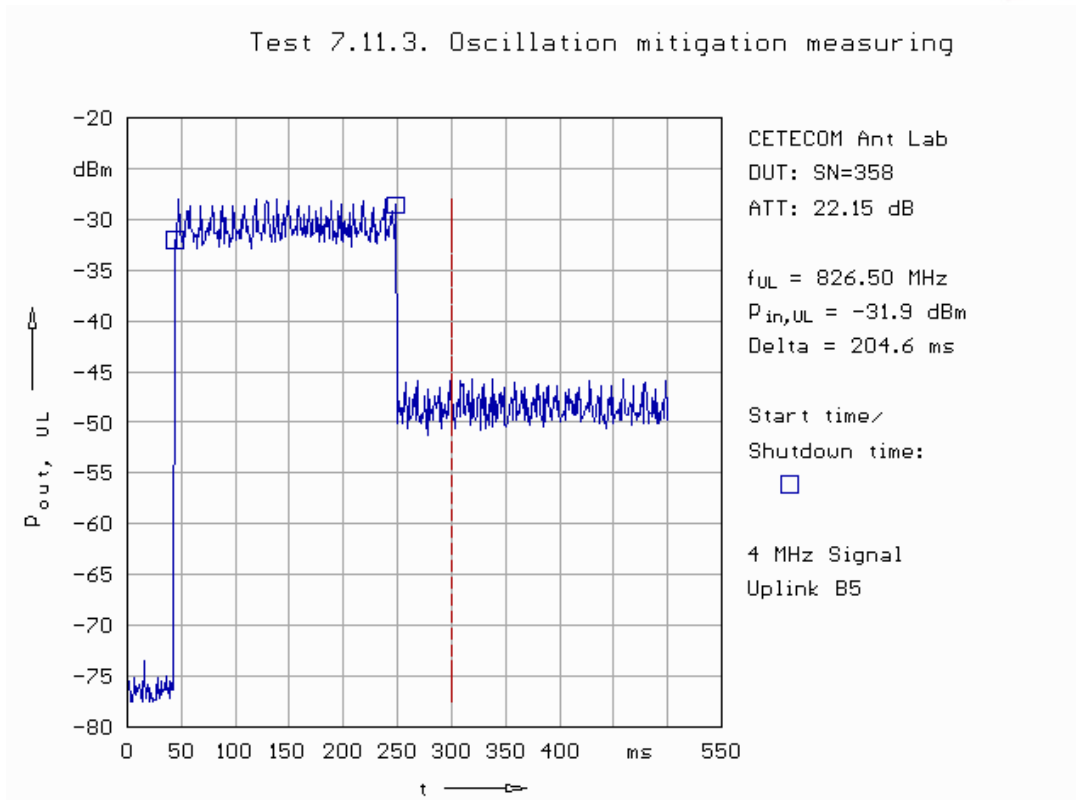

Fig. 315: Band 5 uplink shut down time.

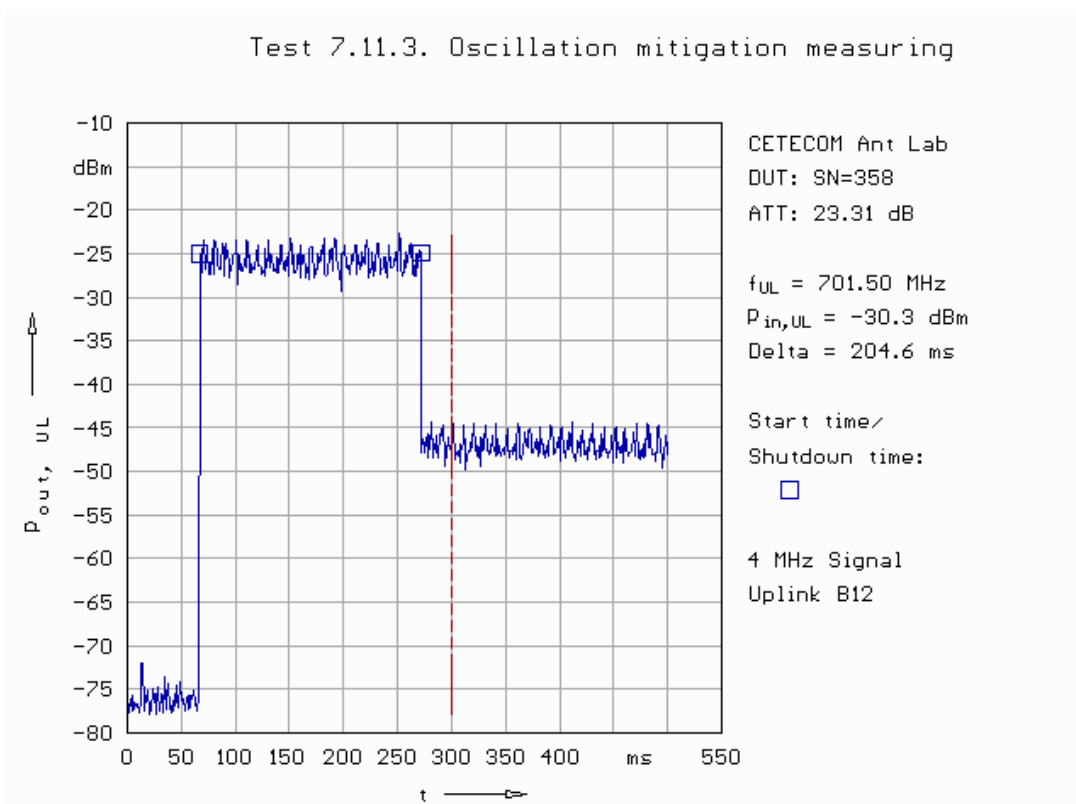

Fig. 316: Band 12 uplink shut down time.

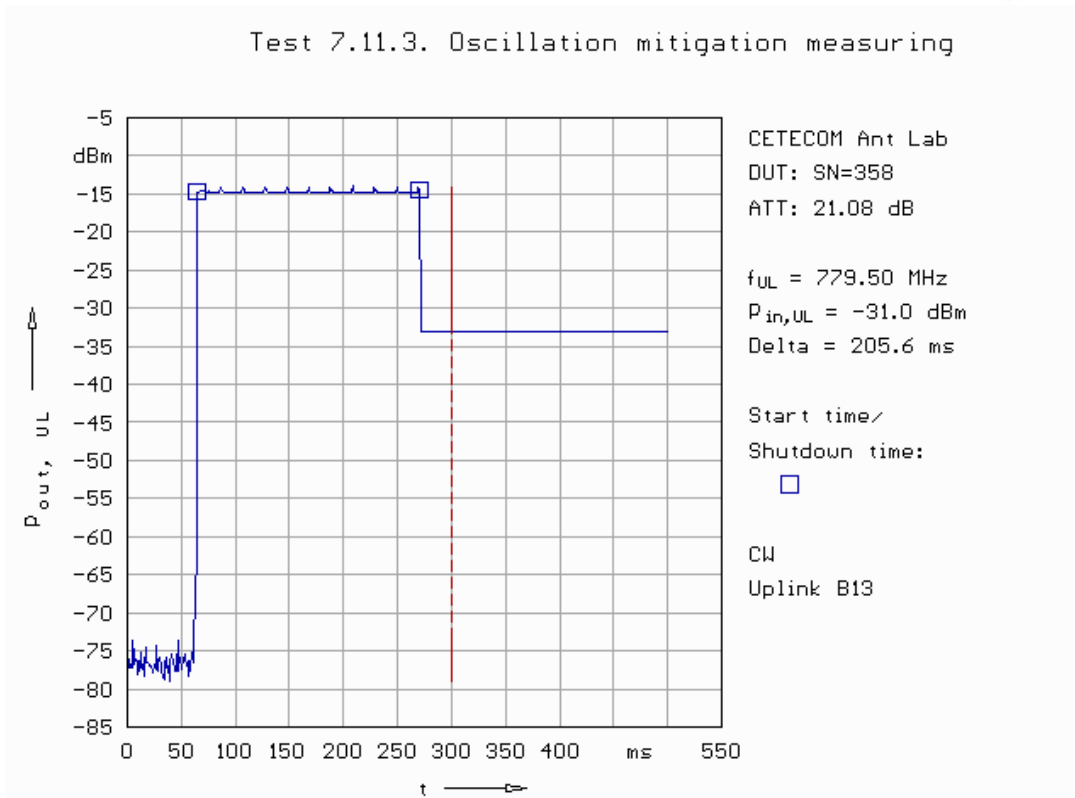

Fig. 317: Band 13 uplink shut down time.

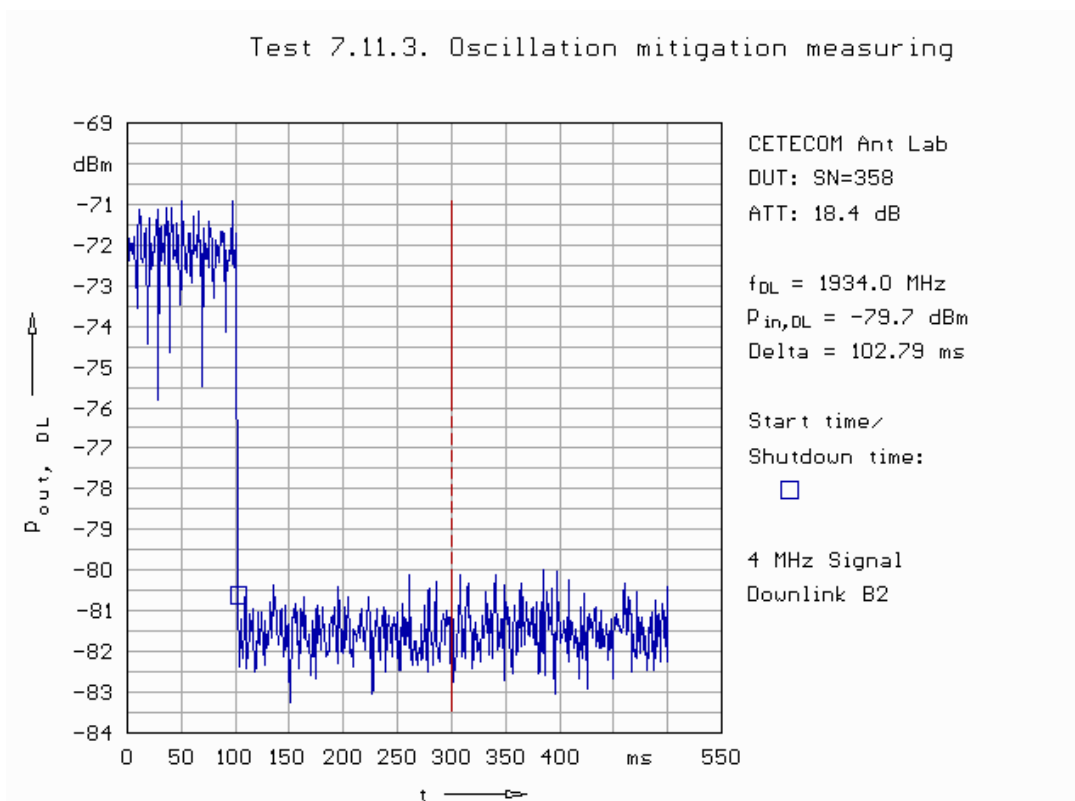

Fig. 318: Band 2 downlink shut down time.

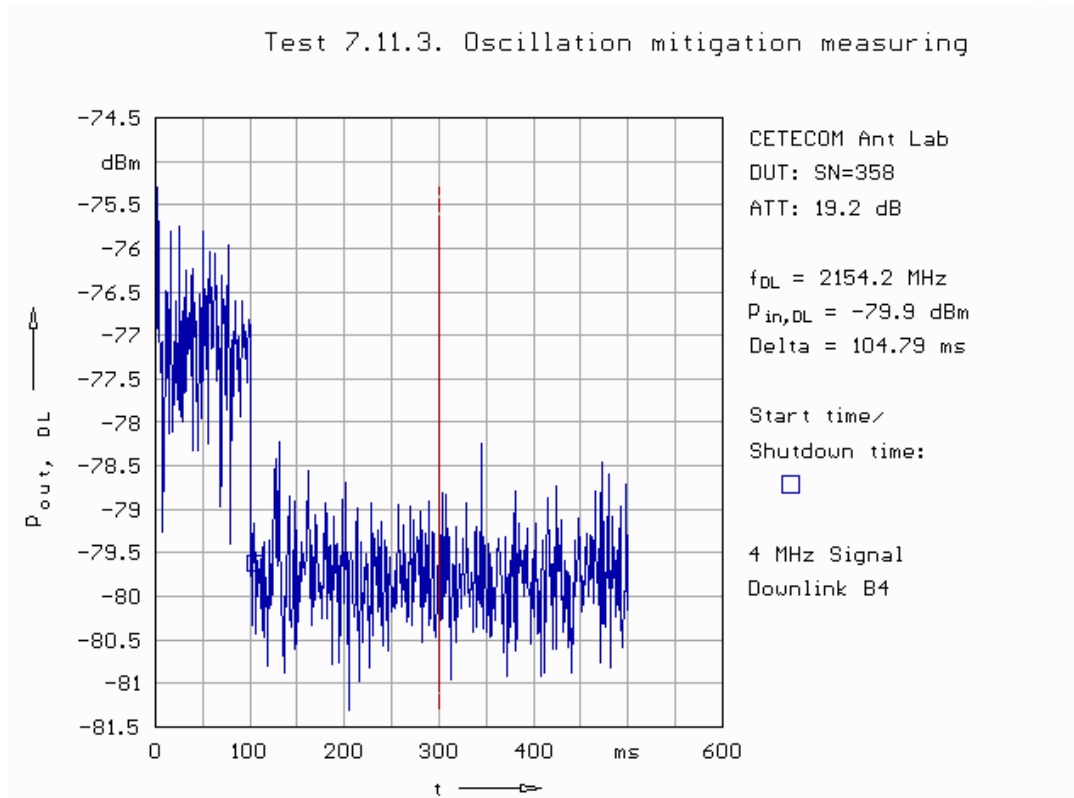

Fig. 319: Band 4 downlink shut down time.

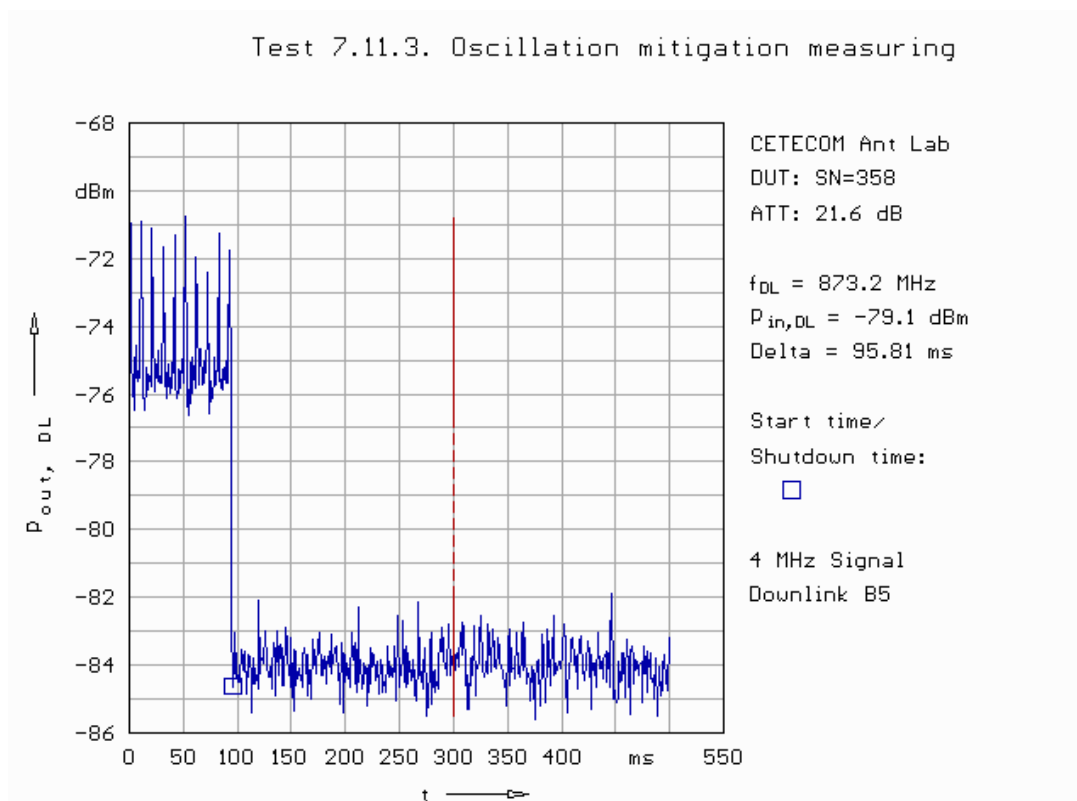

Fig. 320: Band 5 downlink shut down time.

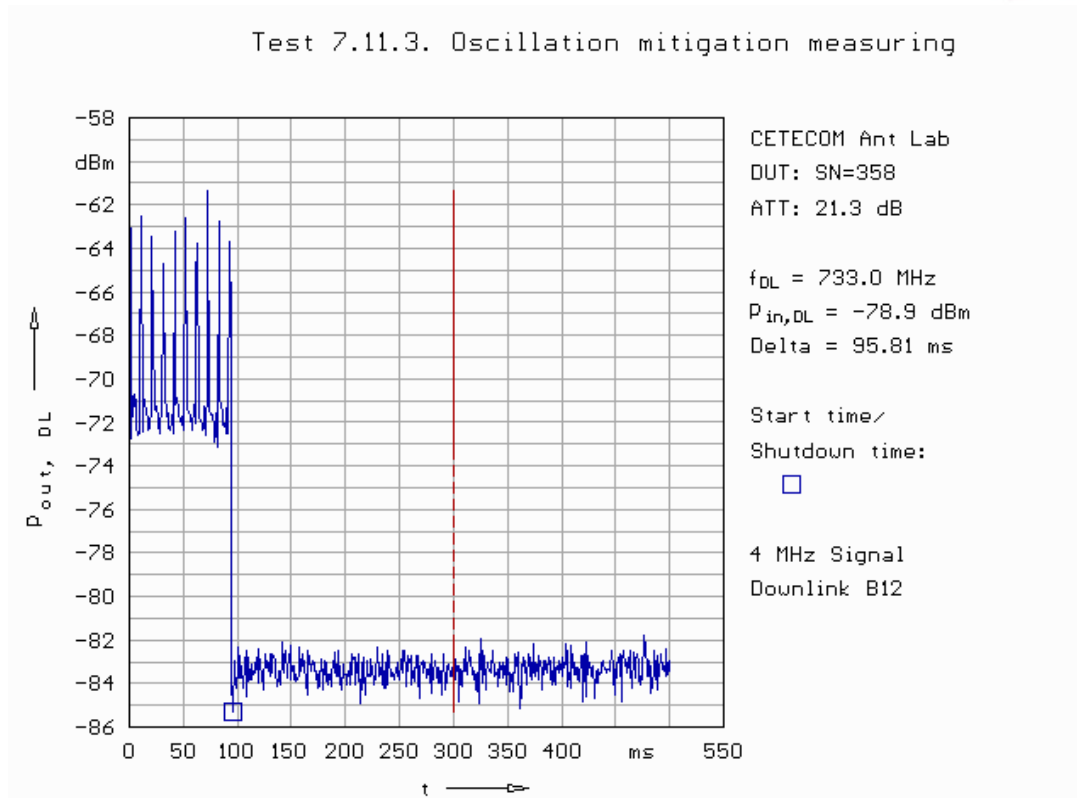

Fig. 321: Band 12 downlink shut down time.

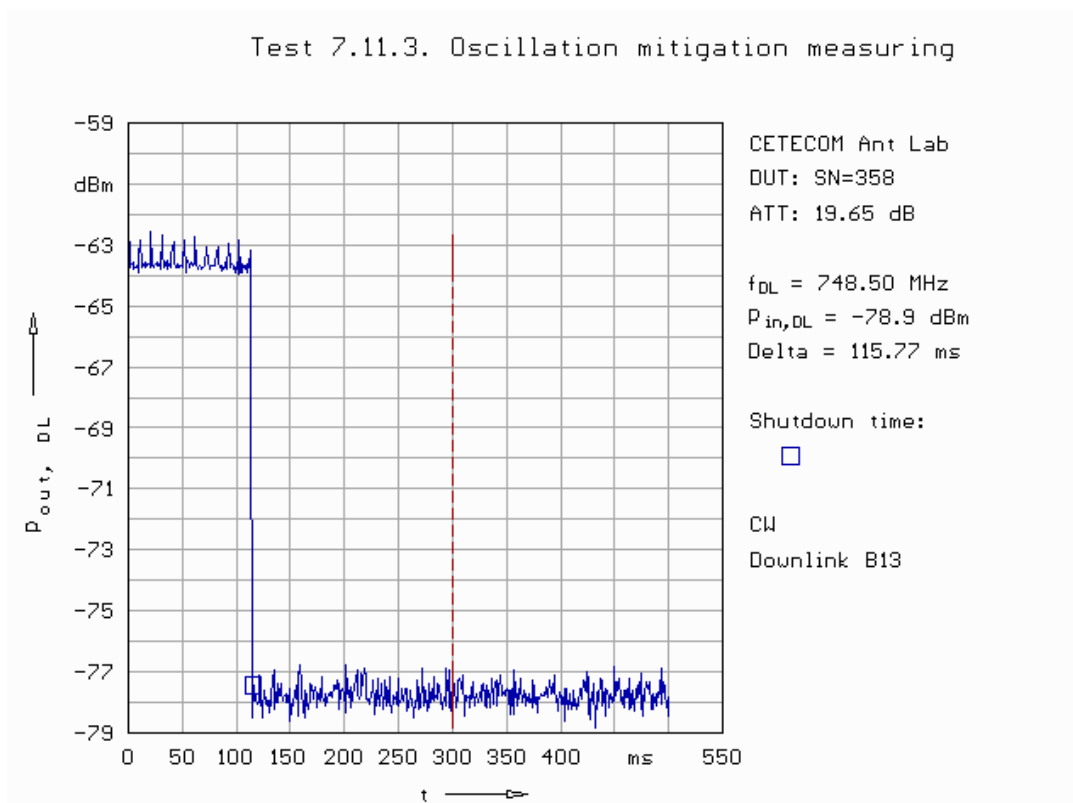

Fig. 322: Band 13 downlink shut down time.

6. Test System

6.1. System Set Up and Test Procedure

The test system used is a semi-automatic system made for testing booster and repeater. As shown in Fig. 323 it consist of a several RF switches, directional couplers, RF sources and a 26.5 GHz spectrum analyzer. All required test scenarios can be created without the need to re-route cable or other RF equipment. All RF paths have been calibrated in respect to the measurement ports (the booster server and donor port) by means of a vector network analyzer. The semi-automatic test procedures capture spectrum analyzer trace results numerically, does take into account the appropriate RF path loss (cable attenuation plus e.g. directional coupler data), and provides a graphical representations of the data at the RF measurements ports.

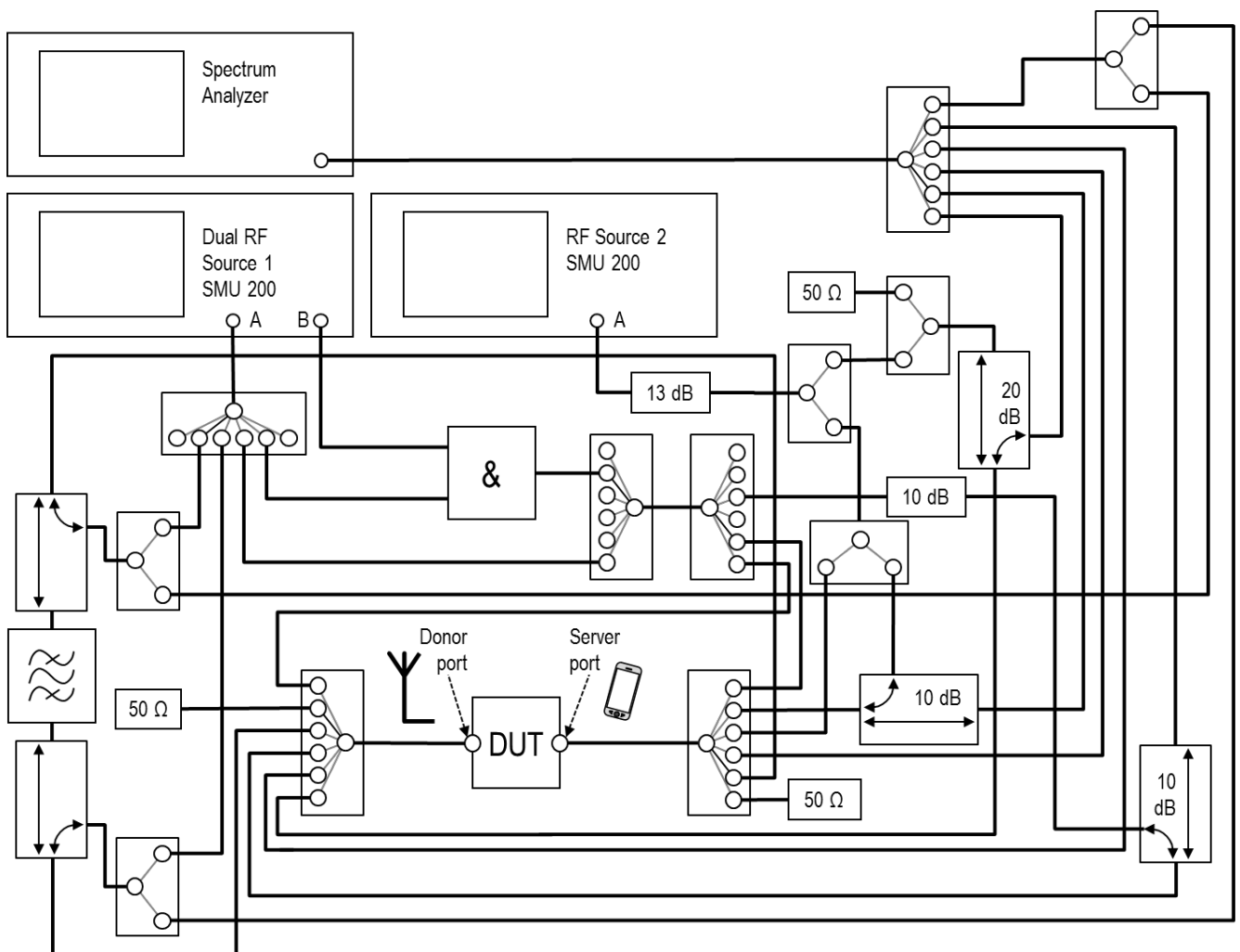

Fig. 323: Complete test system RF routing.

6.2. Measurement Equipment

Equipment	Type	SN	last cal	next cal
RF source	R&S SMU 200A	100754	21.09.2015	22.09.2017
RF source	R&S SMU 200A	1001120	18.11.2015	19.11.2017
Spectrum analyzer	R&S FSU	200152	16.09.2015	17.09.2017
Network Analyzer	Agilent N5230A	US43500426	31.03.2015	30.03.2017
Temperature and Humidity measurement	Opus 10	DL020 / 00302	26.10.2015	25.20.2016

6.3. Measurement Uncertainty

A number of measurements carried out with this test system are based on pure relative measurements: All tests considering a gain are tests, where the uncertainty depends on the repeatability of the RF connections and spectrum analyzer reading repeatability only. To assess this uncertainty contribution some gain measurements have been done by replacing the DUT in by a SMA RF through. The results shown in hence do effectively include the uncertainty of the cable attenuation measurements.

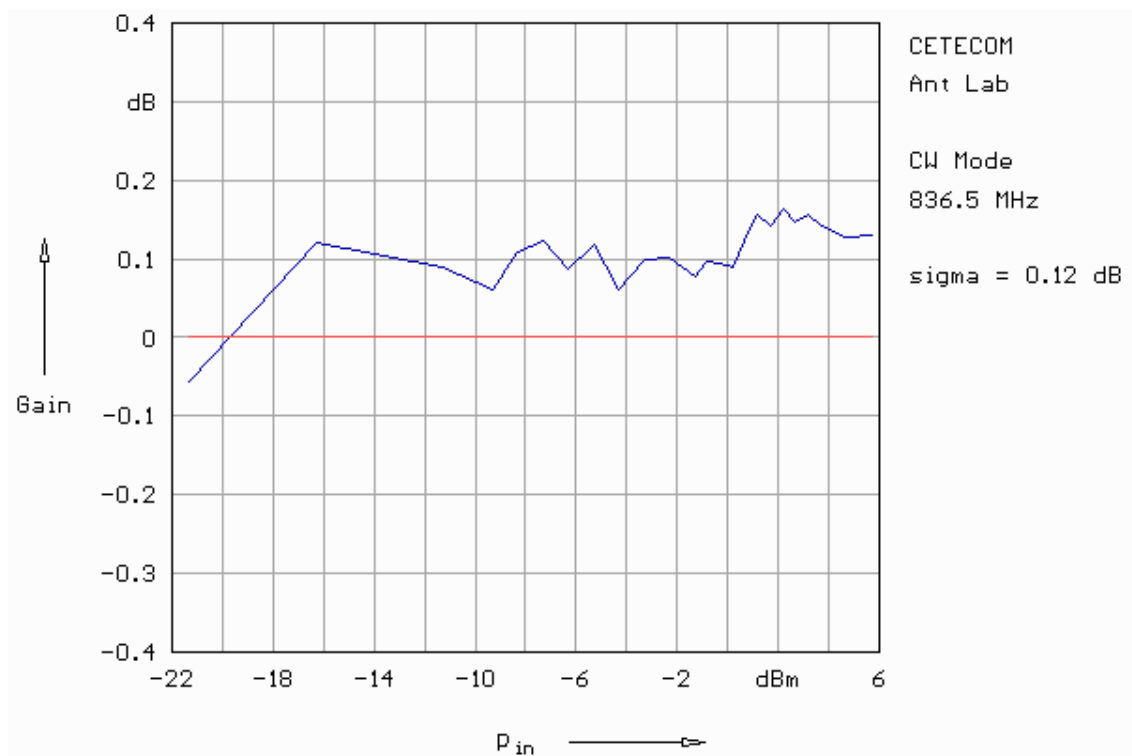

Fig. 324: Gain measurement of a RF through below 1 GHz.

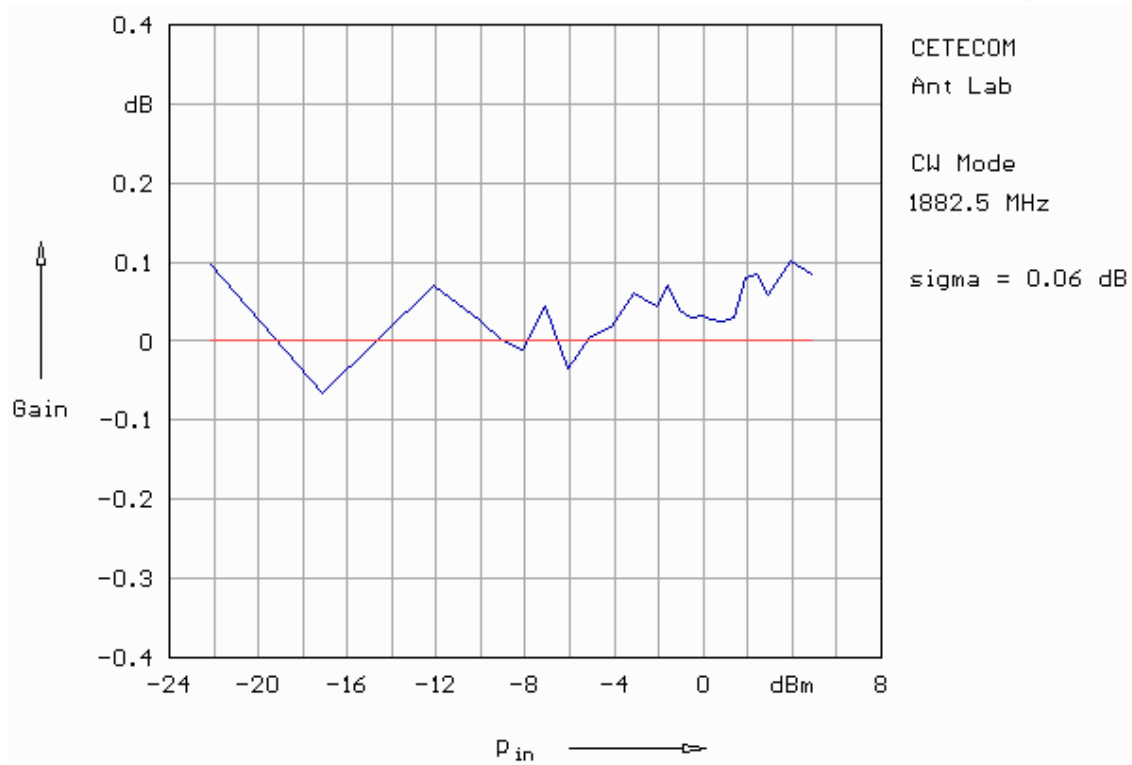

Fig. 325: Gain measurement of a RF through above 1 GHz.

In conclusion we estimated the gain uncertainty of:

$$\Delta \text{gain} < \pm 0.12 \text{ dB.}$$

For absolute measurements the spectrum analyzer properties determine the uncertainty for frequency and RF power levels. According to the data sheet of the Rohde & Schwarz FSU the following data are applicable:

For Frequency it is:

$$\Delta f / f < 0.05 \text{ ppm} + 0.1 \text{ ppm / year.}$$

For a power uncertainty estimation of the following contributions (in terms of standard deviations σ) are taken into account:

nonlinearity at levels > -70 dBm:	0.03 dB	
attenuator switching:	0.07 dB	
relative to reference level:	0.05 dB	
reference level:	0.07 dB	
frequency dependent contribution:	0.10 dB / 0.70 dB	for < 3.6 GHz / 22 GHz.

Additionally the relative (RF switching, cable loss uncertainty): 0.20 dB

eventually add up to an overall RF power uncertainty of:

$$\Delta \text{power} < \pm 0.45 \text{ dB} \quad \text{for frequencies below 3.6 GHz. and}$$

$$\Delta \text{power} < \pm 1.1 \text{ dB} \quad \text{for frequencies up to 22 GHz.}$$

Annex A: Photographs of Test set up(s)

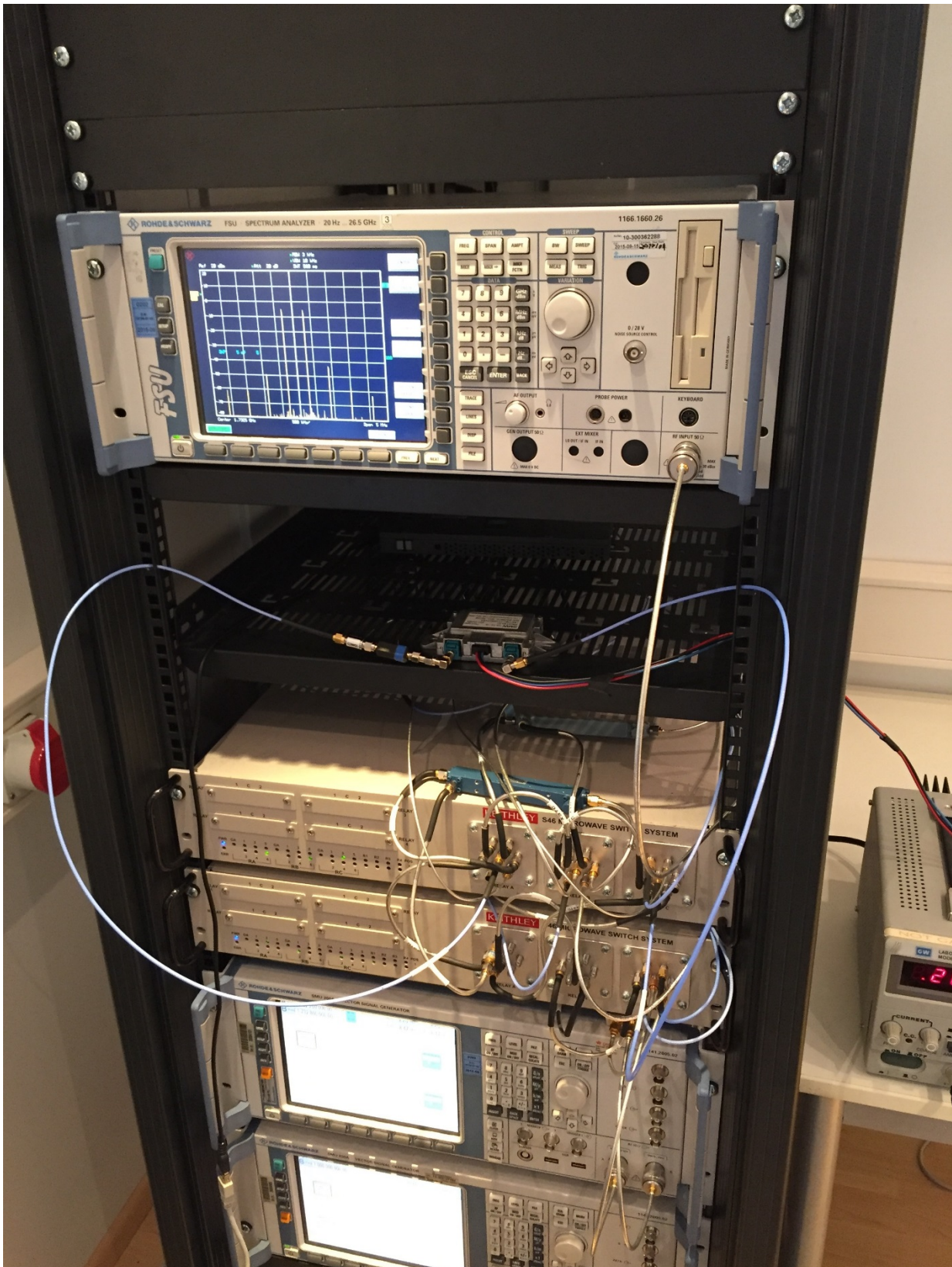



Annex B: External Photographs of the EUT

