



# FCC TEST REPORT (15.247)

**REPORT NO.:** RF150727C28  
**MODEL NO.:** GT7820 & GT7810 & GT7800 & GT78  
**FCC ID:** 2ACC5-GT78  
**RECEIVED:** Jul. 27, 2015  
**TESTED:** Jun. 30, 2015 ~ Aug. 05, 2015  
**ISSUED:** Aug. 13, 2015

**APPLICANT:** AMobile Intelligent Corp.

**ADDRESS:** 18F-1, No 150, Jianyi Road, Zhonghe District, New Taipei City, Taiwan R.O.C

**ISSUED BY:** Bureau Veritas Consumer Products Services (H.K.) Ltd., Taoyuan Branch

**LAB ADDRESS:** No. 47-2, 14th Ling, Chia Pau Vil., Lin Kou Dist., New Taipei City, Taiwan ( R.O.C )

**TEST LOCATION:** No. 19, Hwa Ya 2nd Rd, Wen Hwa Vil., Kwei Shan Dist., Taoyuan City 333, Taiwan, R.O.C.

This report should not be used by the client to claim product certification, approval, or endorsement by TAF or any government agencies.



This report is for your exclusive use. Any copying or replication of this report to or for any other person or entity, or use of our name or trademark, is permitted only with our prior written permission. This report sets forth our findings solely with respect to the test samples identified herein. The results set forth in this report are not indicative or representative of the quality or characteristics of the lot from which a test sample was taken or any similar or identical product unless specifically and expressly noted. Our report includes all of the tests requested by you and the results thereof based upon the information that you provided to us. You have 60 days from date of issuance of this report to notify us of any material error or omission caused by our negligence, provided, however, that such notice shall be in writing and shall specifically address the issue you wish to raise. A failure to raise such issue within the prescribed time shall constitute your unqualified acceptance of the completeness of this report, the tests conducted and the correctness of the report contents. Unless specific mention, the uncertainty of measurement has been explicitly taken into account to declare the compliance or non-compliance to the specification.



# TABLE OF CONTENTS

- RELEASE CONTROL RECORD .....4
- 1. CERTIFICATION.....5
- 2. SUMMARY OF TEST RESULTS .....6
  - 2.1 MEASUREMENT UNCERTAINTY.....6
- 3. GENERAL INFORMATION .....7
  - 3.1 GENERAL DESCRIPTION OF EUT .....7
  - 3.2 DESCRIPTION OF TEST MODES .....9
    - 3.2.1 TEST MODE APPLICABILITY AND TESTED CHANNEL DETAIL ..... 10
  - 3.3 DESCRIPTION OF SUPPORT UNITS ..... 12
    - 3.3.1 CONFIGURATION OF SYSTEM UNDER TEST ..... 12
  - 3.4 DUTY CYCLE TEST SIGNAL ..... 13
  - 3.5 GENERAL DESCRIPTION OF APPLIED STANDARDS ..... 14
- 4. TEST TYPES AND RESULTS (FOR 2.4GHz BAND) ..... 15
  - 4.1 RADIATED EMISSION AND BANDEDGE MEASUREMENT ..... 15
    - 4.1.1 LIMITS OF RADIATED EMISSION AND BANDEDGE MEASUREMENT ..... 15
    - 4.1.2 TEST INSTRUMENTS ..... 16
    - 4.1.3 TEST PROCEDURES ..... 17
    - 4.1.4 DEVIATION FROM TEST STANDARD ..... 17
    - 4.1.5 TEST SETUP ..... 18
    - 4.1.6 EUT OPERATING CONDITIONS ..... 18
    - 4.1.7 TEST RESULTS..... 19
  - 4.2 CONDUCTED EMISSION MEASUREMENT ..... 36
    - 4.2.1 LIMITS OF CONDUCTED EMISSION MEASUREMENT ..... 36
    - 4.2.2 TEST INSTRUMENTS ..... 36
    - 4.2.3 TEST PROCEDURES ..... 37
    - 4.2.4 DEVIATION FROM TEST STANDARD ..... 37
    - 4.2.5 TEST SETUP ..... 38
    - 4.2.6 EUT OPERATING CONDITIONS ..... 38
    - 4.2.7 TEST RESULTS..... 39
  - 4.3 6dB BANDWIDTH MEASUREMENT ..... 45
    - 4.3.1 LIMITS OF 6dB BANDWIDTH MEASUREMENT ..... 45
    - 4.3.2 TEST SETUP ..... 45
    - 4.3.3 TEST INSTRUMENTS ..... 45
    - 4.3.4 TEST PROCEDURE ..... 45
    - 4.3.5 DEVIATION FROM TEST STANDARD ..... 45
    - 4.3.6 EUT OPERATING CONDITIONS ..... 45
    - 4.3.7 TEST RESULTS..... 46
  - 4.4 CONDUCTED OUTPUT POWER ..... 48
    - 4.4.1 LIMITS OF CONDUCTED OUTPUT POWER MEASUREMENT ..... 48
    - 4.4.2 TEST SETUP ..... 48
    - 4.4.3 TEST INSTRUMENTS ..... 48
    - 4.4.4 TEST PROCEDURES ..... 48
    - 4.4.5 DEVIATION FROM TEST STANDARD ..... 48
    - 4.4.6 EUT OPERATING CONDITIONS ..... 48
    - 4.4.7 TEST RESULTS..... 49
  - 4.5 POWER SPECTRAL DENSITY MEASUREMENT ..... 50
    - 4.5.1 LIMITS OF POWER SPECTRAL DENSITY MEASUREMENT ..... 50
    - 4.5.2 TEST SETUP ..... 50
    - 4.5.3 TEST INSTRUMENTS ..... 50
    - 4.5.4 TEST PROCEDURE ..... 50
    - 4.5.5 DEVIATION FROM TEST STANDARD ..... 50
    - 4.5.6 EUT OPERATING CONDITION ..... 50



A D T

4.5.7	TEST RESULTS.....	51
4.6	CONDUCTED OUT OF BAND EMISSION MEASUREMENT .....	53
4.6.1	LIMITS OF CONDUCTED OUT OF BAND EMISSION MEASUREMENT .....	53
4.6.2	TEST SETUP .....	53
4.6.3	TEST INSTRUMENTS .....	53
4.6.4	TEST PROCEDURE .....	53
4.6.5	DEVIATION FROM TEST STANDARD .....	53
4.6.6	EUT OPERATING CONDITION.....	53
4.6.7	TEST RESULTS.....	54
5.	PHOTOGRAPHS OF THE TEST CONFIGURATION.....	62
6.	INFORMATION ON THE TESTING LABORATORIES .....	63
7.	APPENDIX A – MODIFICATIONS RECORDERS FOR ENGINEERING CHANGES TO THE EUT BY THE LAB .....	64



A D T

## RELEASE CONTROL RECORD

ISSUE NO.	REASON FOR CHANGE	DATE ISSUED
RF150727C28	Original release	Aug. 13, 2015



## 1. CERTIFICATION

**PRODUCT:** Rugged Android Tablet  
**MODEL NO.:** GT7820 & GT7810 & GT7800 & GT78  
**BRAND:** Amobile  
**APPLICANT:** AMobile Intelligent Corp.  
**TESTED:** Jun. 30, 2015 ~ Aug. 05, 2015  
**TEST SAMPLE:** Identical Prototype  
**STANDARDS:** **FCC Part 15, Subpart C (Section 15.247)**  
ANSI C63.10-2013

The above equipment (model: GT7820 & GT7810 & GT7800 & GT78) has been tested by **Bureau Veritas Consumer Products Services (H.K.) Ltd., Taoyuan Branch**, and found compliance with the requirement of the above standards. The test record, data evaluation & Equipment Under Test (EUT) configurations represented herein are true and accurate accounts of the measurements of the sample's EMC characteristics under the conditions specified in this report.

**PREPARED BY** : Gina Liu , **DATE** : Aug. 13, 2015  
Gina Liu / Specialist

**APPROVED BY** : Kay Wu , **DATE** : Aug. 13, 2015  
Kay Wu / Supervisor

## 2. SUMMARY OF TEST RESULTS

The EUT has been tested according to the following specifications:

APPLIED STANDARD: FCC PART 15, SUBPART C (SECTION 15.247)			
STANDARD SECTION	TEST TYPE	RESULT	REMARK
15.207	AC Power Conducted Emission	PASS	Meet the requirement of limit. Minimum passing margin is -7.60dB at 1.84709MHz.
15.205 & 15.209	Radiated Emissions	PASS	Meet the requirement of limit. Minimum passing margin is -3.00dB at 2388MHz.
15.247(d)	Band Edge Measurement	PASS	Meet the requirement of limit.
15.247(d)	Antenna Port Emission	PASS	Meet the requirement of limit.
15.247(a)(2)	6dB bandwidth	PASS	Meet the requirement of limit.
15.247(b)	Conducted power	PASS	Meet the requirement of limit.
15.247(e)	Power Spectral Density	PASS	Meet the requirement of limit.
15.203	Antenna Requirement	PASS	No antenna connector is used.

### 2.1 MEASUREMENT UNCERTAINTY

Where relevant, the following measurement uncertainty levels have been estimated for tests performed on the EUT as specified in CISPR 16-4-2:

MEASUREMENT	FREQUENCY	UNCERTAINTY
Conducted emissions	9kHz~30MHz	2.44 dB
Radiated emissions	30MHz ~ 200MHz	2.93 dB
	200MHz ~1000MHz	2.95 dB
	1GHz ~ 18GHz	2.26 dB
	18GHz ~ 40GHz	1.94 dB

This uncertainty represents an expanded uncertainty expressed at approximately the 95% confidence level using a coverage factor of  $k = 2$ .



### 3. GENERAL INFORMATION

#### 3.1 GENERAL DESCRIPTION OF EUT

<b>EUT</b>	Rugged Android Tablet
<b>MODEL NO.</b>	GT7820 & GT7810 & GT7800 & GT78
<b>POWER SUPPLY</b>	5.0Vdc (adapter or host equipment) 3.8Vdc (Li-ion battery)
<b>MODULATION TYPE</b>	CCK, DQPSK, DBPSK for DSSS 64QAM, 16QAM, QPSK, BPSK for OFDM
<b>MODULATION TECHNOLOGY</b>	DSSS, OFDM
<b>TRANSFER RATE</b>	802.11b: 11.0 / 5.5 / 2.0 / 1.0 Mbps 802.11g: 54.0 / 48.0 / 36.0 / 24.0 / 18.0 / 12.0 / 9.0 / 6.0 Mbps 802.11n: up to MCS7
<b>OPERATING FREQUENCY</b>	2412 ~ 2462MHz
<b>NUMBER OF CHANNEL</b>	11 for 802.11b, 802.11g, 802.11n (20MHz) 7 for 802.11n (40MHz)
<b>OUTPUT POWER</b>	178.24mW for 2412 ~ 2462MHz
<b>ANTENNA TYPE</b>	PIFA antenna with 2.70dBi gain
<b>ANTENNA CONNECTOR</b>	NA
<b>DATA CABLE</b>	Refer to Note as below
<b>I/O PORTS</b>	Refer to user's manual
<b>ACCESSORY DEVICES</b>	Refer to Note as below

**NOTE:**

1. All models are listed as below.

<b>BRAND</b>	<b>MODEL</b>	<b>DIFFERENCE</b>
Amobile	GT78	EUT without barcode
	GT7800	EUT without barcode
	GT7810	EUT with 1D barcode
	GT7820	EUT with 2D barcode

GT78 and GT7800 are electrically identical, different model names are for marketing purpose.

2. Test Configurations are listed as below.

<b>Sample</b>	<b>MODEL</b>
A	GT7800
B	GT7810
C	GT7820



A D T

3. The EUT contains following accessory devices.

ITEM	BRAND	MODEL	SPECIFICATION
Battery	JAPON	TP0750B01	3.8Vdc, 6200mAh
Earphone	HETONG	PY-1312602-09KB02	1.2m
USB Cable	miki	YXT-64-MK5P-1M	0.98m
LCD Panel	K&D	KD079D1-35NA-A1	7.8 Inch
Photo Camera	SEASONS	SPV6B9298	--
Video Camera	Wdson	WDS1NA44W552	--
WWAN Module	MTK	MT6166	--
WLAN Module	MTK	MT6627	--
CPU	MTK	MT8382	1.3GHZ
MainBoard	miki	P6128	--
EMMC	N/A	NCEFES78-08G	8GB
bar code scanner (2D)	opticon	MDI-3100	--
bar code scanner (1D)	opticon	MDC-100	--

4. The EUT provides one completed transmitter and one receiver.

MODULATION MODE	TX FUNCTION
802.11b	1TX
802.11g	1TX
802.11n (20MHz)	1TX
802.11n (40MHz)	1TX

5. The above EUT information is declared by the manufacturer and for more detailed features description, please refer to the manufacturer's specifications or User's Manual.



### 3.2 DESCRIPTION OF TEST MODES

#### FOR 2.4GHz:

11 channels are provided for 802.11b, 802.11g and 802.11n (20MHz):

CHANNEL	FREQUENCY	CHANNEL	FREQUENCY
1	2412MHz	7	2442MHz
2	2417MHz	8	2447MHz
3	2422MHz	9	2452MHz
4	2427MHz	10	2457MHz
5	2432MHz	11	2462MHz
6	2437MHz		

7 channels are provided for 802.11n (40MHz):

CHANNEL	FREQUENCY	CHANNEL	FREQUENCY
3	2422MHz	7	2442MHz
4	2427MHz	8	2447MHz
5	2432MHz	9	2452MHz
6	2437MHz		



### 3.2.1 TEST MODE APPLICABILITY AND TESTED CHANNEL DETAIL

#### WLAN 2.4GHz:

EUT CONFIGURE MODE	APPLICABLE TO				DESCRIPTION
	RE≥1G	RE<1G	PLC	APCM	
A	√	√	√	√	Sample C
B	√	√	√	-	Sample A
C	√	√	√	-	Sample B

Where **RE≥1G**: Radiated Emission above 1GHz      **RE<1G**: Radiated Emission below 1GHz  
**PLC**: Power Line Conducted Emission      **APCM**: Antenna Port Conducted Measurement

**NOTE:** The EUT had been pre-tested on the positioned of each 3 axis. The worst case was found when positioned on **X-plane for MODE A, B and Y-plane for MODE C.**

#### RADIATED EMISSION TEST (ABOVE 1GHz):

- Pre-Scan has been conducted to determine the worst-case mode from all possible combinations between available modulations, data rates and antenna ports (if EUT with antenna diversity architecture).
- Following channel(s) was (were) selected for the final test as listed below.

EUT CONFIGURE MODE	MODE	AVAILABLE CHANNEL	TESTED CHANNEL	MODULATION TECHNOLOGY	MODULATION TYPE	DATA RATE (Mbps)
A	802.11b	1 to 11	1, 6, 11	DSSS	DBPSK	1.0
A	802.11g	1 to 11	1, 6, 11	OFDM	BPSK	6.0
A	802.11n (20MHz)	1 to 11	1, 6, 11	OFDM	BPSK	MCS0
A	802.11n (40MHz)	3 to 9	3, 6, 9	OFDM	BPSK	MCS0
B, C	802.11n (40MHz)	3 to 9	3	OFDM	BPSK	MCS0

#### RADIATED EMISSION TEST (BELOW 1GHz):

- Pre-Scan has been conducted to determine the worst-case mode from all possible combinations between available modulations, data rates and antenna ports (if EUT with antenna diversity architecture).
- Following channel(s) was (were) selected for the final test as listed below.

EUT CONFIGURE MODE	MODE	AVAILABLE CHANNEL	TESTED CHANNEL	MODULATION TECHNOLOGY	MODULATION TYPE	DATA RATE (Mbps)
A, B, C	802.11n (40MHz)	3 to 9	3	OFDM	BPSK	MCS0



A D T

**POWER LINE CONDUCTED EMISSION TEST:**

- Pre-Scan has been conducted to determine the worst-case mode from all possible combinations between available modulations, data rates and antenna ports (if EUT with antenna diversity architecture).
- Following channel(s) was (were) selected for the final test as listed below.

EUT CONFIGURE MODE	MODE	AVAILABLE CHANNEL	TESTED CHANNEL	MODULATION TECHNOLOGY	MODULATION TYPE	DATA RATE (Mbps)
A, B, C	802.11n (40MHz)	3 to 9	3	OFDM	BPSK	MCS0

**BANDEGE MEASUREMENT:**

- Pre-Scan has been conducted to determine the worst-case mode from all possible combinations between available modulations, data rates and antenna ports (if EUT with antenna diversity architecture).
- Following channel(s) was (were) selected for the final test as listed below.

EUT CONFIGURE MODE	MODE	AVAILABLE CHANNEL	TESTED CHANNEL	MODULATION TECHNOLOGY	MODULATION TYPE	DATA RATE (Mbps)
A	802.11b	1 to 11	1, 6, 11	DSSS	DBPSK	1.0
A	802.11g	1 to 11	1, 6, 11	OFDM	BPSK	6.0
A	802.11n (20MHz)	1 to 11	1, 6, 11	OFDM	BPSK	MCS0
A	802.11n (40MHz)	3 to 9	3, 6, 9	OFDM	BPSK	MCS0

**ANTENNA PORT CONDUCTED MEASUREMENT:**

- This item includes all test value of each mode, but only includes spectrum plot of worst value of each mode.
- Pre-Scan has been conducted to determine the worst-case mode from all possible combinations between available modulations, data rates and antenna ports (if EUT with antenna diversity architecture).
- Following channel(s) was (were) selected for the final test as listed below.

EUT CONFIGURE MODE	MODE	AVAILABLE CHANNEL	TESTED CHANNEL	MODULATION TECHNOLOGY	MODULATION TYPE	DATA RATE (Mbps)
A	802.11b	1 to 11	1, 6, 11	DSSS	DBPSK	1.0
A	802.11g	1 to 11	1, 6, 11	OFDM	BPSK	6.0
A	802.11n (20MHz)	1 to 11	1, 6, 11	OFDM	BPSK	MCS0
A	802.11n (40MHz)	3 to 9	3, 6, 9	OFDM	BPSK	MCS0

**TEST CONDITION:**

APPLICABLE TO	ENVIRONMENTAL CONDITIONS	INPUT POWER	TESTED BY
RE≥1G	25deg. C, 65%RH	120Vac, 60Hz	Charles Hsiao, Karl Lee
RE<1G	25deg. C, 65%RH	120Vac, 60Hz	Charles Hsiao, Harry Hsueh
PLC	25deg. C, 65%RH	120Vac, 60Hz	Toby Tian
APCM	25deg. C, 65%RH	3.8Vdc	Taylor Liu

**3.3 DESCRIPTION OF SUPPORT UNITS**

The EUT has been tested as an independent unit together with other necessary accessories or support units. The following support units or accessories were used to form a representative test configuration during the tests.

NO.	PRODUCT	BRAND	MODEL NO.	SERIAL NO.	FCC ID
1	Adapter	AMIGO	AMS135-0502000FU	N/A	N/A

NO.	SIGNAL CABLE DESCRIPTION OF THE ABOVE SUPPORT UNITS
1	1.5m shielded cable w/o core

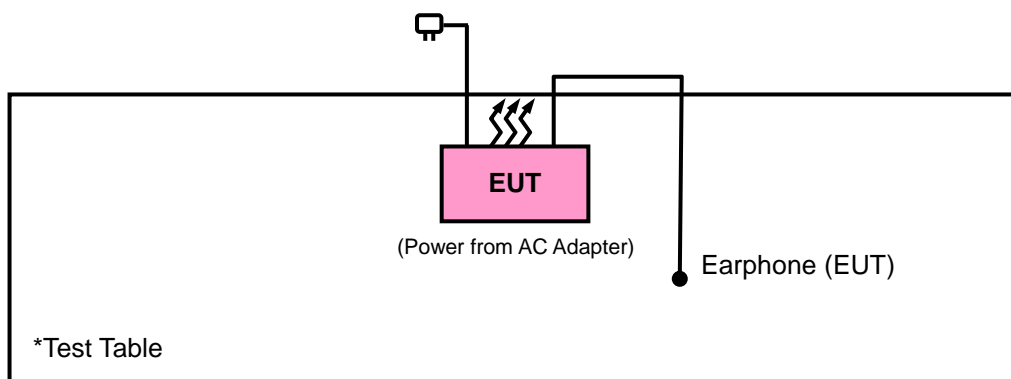
**3.3.1 CONFIGURATION OF SYSTEM UNDER TEST**

### 3.4 DUTY CYCLE TEST SIGNAL

#### WLAN 2.4GHz

**802.11b:** Duty cycle of test signal is 100 %

**802.11g:** Duty cycle =  $1.386/1.57 = 0.883$ , Duty factor =  $10 * \log(1/0.883) = 0.54$

**802.11n (20MHz):** Duty cycle =  $1.291/1.475 = 0.875$ , Duty factor =  $10 * \log(1/0.875) = 0.58$

**802.11n (40MHz):** Duty cycle =  $608.33/825.64 = 0.764$ , Duty factor =  $10 * \log(1/0.764) = 1.17$

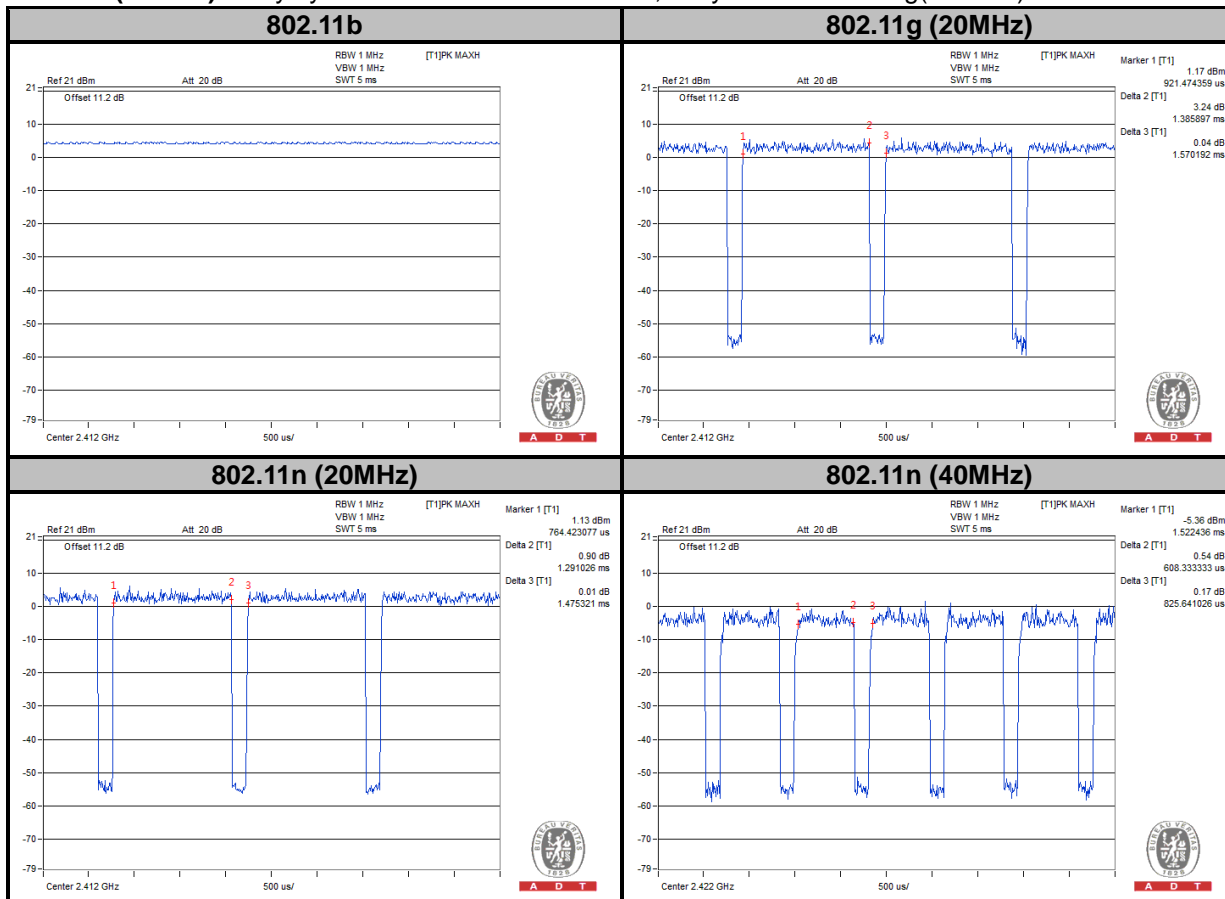



### **3.5 GENERAL DESCRIPTION OF APPLIED STANDARDS**

The EUT is a RF Product. According to the specifications of the manufacturer, it must comply with the requirements of the following standards:

**FCC Part 15, Subpart C (15.247)**

**558074 D01 DTS Meas Guidance v03r03**

ANSI C63.10-2013

All test items have been performed and recorded as per the above standards.

**NOTE:** The EUT has been verified to comply with the requirements of FCC Part 15, Subpart B, Class B (DoC). The test report has been issued separately.

## 4. TEST TYPES AND RESULTS (FOR 2.4GHz BAND)

### 4.1 RADIATED EMISSION AND BANDEDGE MEASUREMENT

#### 4.1.1 LIMITS OF RADIATED EMISSION AND BANDEDGE MEASUREMENT

Radiated emissions which fall in the restricted bands must comply with the radiated emission limits specified as below table. Other emissions shall be at least 20dB below the highest level of the desired power:

FREQUENCIES (MHz)	FIELD STRENGTH (microvolts/meter)	MEASUREMENT DISTANCE (meters)
0.009 ~ 0.490	2400/F(kHz)	300
0.490 ~ 1.705	24000/F(kHz)	30
1.705 ~ 30.0	30	30
30 ~ 88	100	3
88 ~ 216	150	3
216 ~ 960	200	3
Above 960	500	3

**NOTE:**

1. The lower limit shall apply at the transition frequencies.
2. Emission level (dBuV/m) = 20 log Emission level (uV/m).
3. For frequencies above 1000MHz, the field strength limits are based on average detector, however, the peak field strength of any emission shall not exceed the maximum permitted average limits, specified above by more than 20dB under any condition of modulation.



A D T

#### 4.1.2 TEST INSTRUMENTS

DESCRIPTION & MANUFACTURER	MODEL NO.	SERIAL NO.	DATE OF CALIBRATION	DUE DATE OF CALIBRATION
Spectrum Analyzer Agilent Technologies	N9038A	MY52260177	May 19, 2015	May 18, 2016
Spectrum Analyzer ROHDE & SCHWARZ	FSU43	101261	Dec. 10, 2014	Dec. 09, 2015
BILOG Antenna SCHWARZBECK	VULB9168	9168-472	Feb. 04, 2015	Feb. 04, 2016
HORN Antenna SCHWARZBECK	3117	00143293	Aug. 28, 2014	Aug. 27, 2015
HORN Antenna SCHWARZBECK	BBHA 9170	9170-480	Aug. 27, 2014	Aug. 26, 2015
Loop Antenna	HFH2-Z2	100070	Mar. 06, 2014	Mar. 05, 2016
Preamplifier EMCI	EMC 012645	980115	Dec. 12, 2014	Dec. 11, 2015
Preamplifier EMCI	EMC 184045	980116	Jan. 09, 2015	Jan. 08, 2016
Preamplifier EMCI	EMC 330H	980112	Dec. 25, 2014	Dec. 24, 2015
RF signal cable HUBER+SUHNNER	SUCOFLEX 104	309219/4 2950114	Oct. 18, 2014	Oct. 17, 2015
RF signal cable HUBER+SUHNNER	SUCOFLEX 104	250130/4	Oct. 18, 2014	Oct. 17, 2015
RF signal cable Worken	RG-213	NA	Nov. 07, 2014	Nov. 06, 2015
Software BV ADT	E3 6.120103	NA	NA	NA
Antenna Tower MF	MFA-440H	NA	NA	NA
Turn Table MF	MFT-201SS	NA	NA	NA
Antenna Tower & Turn Table Controller MF	MF-7802	NA	NA	NA
Bluetooth Tester	CBT	100980	Feb. 10, 2015	Feb. 09, 2016
Power Meter	ML2495A	1232002	Sep. 17, 2014	Sep. 16, 2015
Power Sensor	MA2411B	1207325	Sep. 17, 2014	Sep. 16, 2015

- NOTE:**
1. The calibration interval of the above test instruments is 12 months and the calibrations are traceable to NML/ROC and NIST/USA.
  2. The calibration interval of the loop antenna is 24 months and the calibrations are traceable to NML/ROC and NIST/USA.
  3. The test was performed in HwaYa Chamber 10.
  4. The horn antenna and HP preamplifier (model: 8449B) are used only for the measurement of emission frequency above 1GHz if tested.
  5. The FCC Site Registration No. is 690701.
  6. The IC Site Registration No. is IC 7450F-10.



#### 4.1.3 TEST PROCEDURES

- a. The EUT was placed on the top of a rotating table 0.8 meters (for below 1GHz) / 1.5 meters (for above 1GHz) above the ground at 3 meter chamber room for test. The table was rotated 360 degrees to determine the position of the highest radiation.
- b. The EUT was set 3 meters away from the interference-receiving antenna, which was mounted on the top of a variable-height antenna tower.
- c. Height of receiving antenna is varied from one meter to four meters above the ground to determine the maximum value of the field strength. Both horizontal and vertical polarizations of the antenna are set to make the measurement.
- d. For each suspected emission, the EUT was arranged to its worst case and then the antenna was tuned to heights from 1 meter to 4 meters and the rotatable table was turned from 0 degrees to 360 degrees to find the maximum reading.
- e. The test-receiver system was set to Peak Detect Function and Specified Bandwidth with Maximum Hold Mode.
- f. If the emission level of the EUT in peak mode was lower than the limit specified, then testing could be stopped and the peak values of the EUT would be reported. Otherwise the emissions would be re-tested one by one using peak, quasi-peak or average method as specified and then reported in a data sheet.

**NOTE:**

1. The resolution bandwidth and video bandwidth of test receiver/spectrum analyzer is 120kHz for Quasi-peak detection at frequency below 1GHz.
2. The resolution bandwidth of test receiver/spectrum analyzer is 1MHz and video bandwidth is 3MHz for Peak detection at frequency above 1GHz.
3. The resolution bandwidth of test receiver/spectrum analyzer is 1MHz and the video bandwidth is 1kHz (Duty cycle < 98%) or 10Hz (Duty cycle > 98%) for Average detection (AV) at frequency above 1GHz.
4. All modes of operation were investigated and the worst-case emissions are reported.

#### 4.1.4 DEVIATION FROM TEST STANDARD

No deviation.

#### 4.1.5 TEST SETUP

<Frequency Range 30MHz ~ 1GHz>

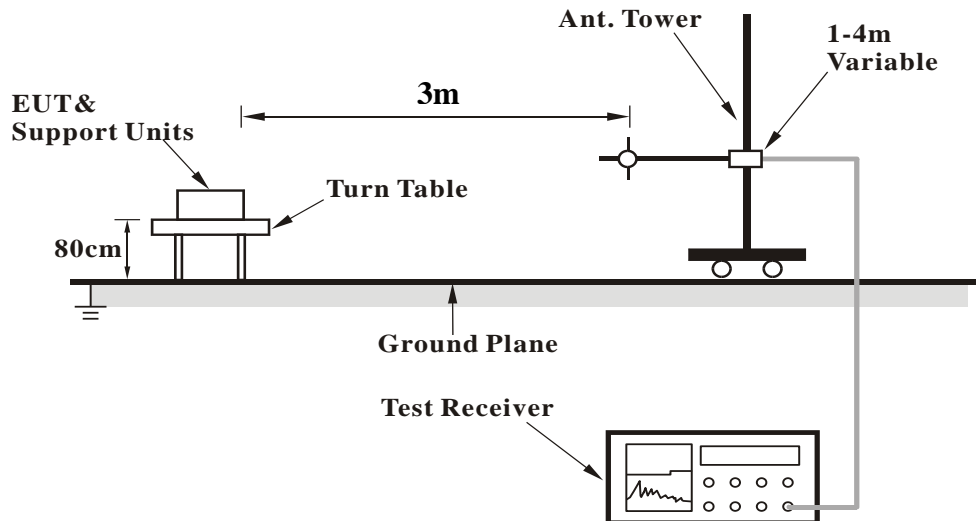

<Frequency Range above 1GHz>

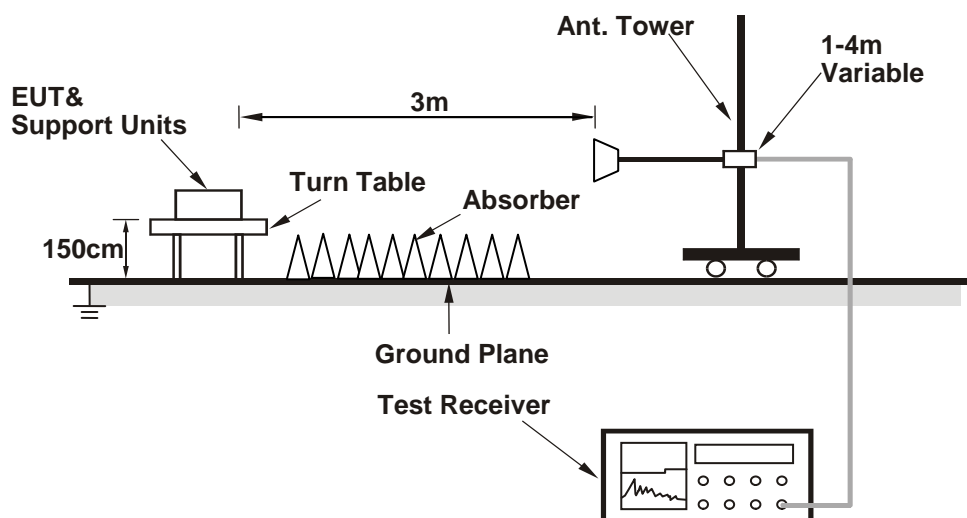

For the actual test configuration, please refer to the attached file (Test Setup Photo).

#### 4.1.6 EUT OPERATING CONDITIONS

- Placed the EUT on a testing table.
- Use the software to control the EUT under transmission condition continuously at specific channel frequency.



A D T

#### 4.1.7 TEST RESULTS

#### ABOVE 1GHz WORST-CASE DATA

#### MODE A

#### 802.11b

EUT TEST CONDITION		MEASUREMENT DETAIL	
CHANNEL	Channel 1	FREQUENCY RANGE	1GHz ~ 25GHz
INPUT POWER	120Vac, 60 Hz	DETECTOR FUNCTION	Peak (PK) Average (AV)
ENVIRONMENTAL CONDITIONS	25deg. C, 65%RH	TESTED BY	Charles Hsiao

ANTENNA POLARITY & TEST DISTANCE: HORIZONTAL AT 3 M										
FREQ. (MHz)	EMISSION LEVEL (dBuV/m)	READ LEVEL (dBuV)	LIMIT (dBuV/m)	MARGIN (dB)	ANTENNA FACTOR (dB/m)	CABLE LOSS (dB)	PREAMP FACTOR (dB)	ANTENNA HEIGHT (cm)	TABLE ANGLE (Degree)	REMARK
2370	40.75	38.69	54	-13.25	31.78	5.77	35.49	111	177	Average
2370	56.51	54.45	74	-17.49	31.78	5.77	35.49	111	177	Peak
2412	95.02	92.87			31.81	5.81	35.47	111	177	Average
2412	97.54	95.39			31.81	5.81	35.47	111	177	Peak
2488	40.23	37.82	54	-13.77	31.9	5.93	35.42	111	177	Average
2488	56.49	54.08	74	-17.51	31.9	5.93	35.42	111	177	Peak
ANTENNA POLARITY & TEST DISTANCE: VERTICAL AT 3 M										
FREQ. (MHz)	EMISSION LEVEL (dBuV/m)	READ LEVEL (dBuV)	LIMIT (dBuV/m)	MARGIN (dB)	ANTENNA FACTOR (dB/m)	CABLE LOSS (dB)	PREAMP FACTOR (dB)	ANTENNA HEIGHT (cm)	TABLE ANGLE (Degree)	REMARK
2376	41.65	39.59	54	-12.35	31.78	5.77	35.49	103	161	Average
2376	56.62	54.56	74	-17.38	31.78	5.77	35.49	103	161	Peak
2412	98.02	95.87			31.81	5.81	35.47	103	161	Average
2412	100.7	98.55			31.81	5.81	35.47	103	161	Peak
2500	40.33	37.91	54	-13.67	31.9	5.93	35.41	103	161	Average
2500	56.25	53.83	74	-17.75	31.9	5.93	35.41	103	161	Peak

#### REMARKS:

- Emission Level = Read Level + Antenna Factor + Cable Loss - Preamp Factor  
Margin value = Emission level – Limit value
- 2412MHz: Fundamental frequency.



A D T

EUT TEST CONDITION		MEASUREMENT DETAIL	
CHANNEL	Channel 6	FREQUENCY RANGE	1GHz ~ 25GHz
INPUT POWER	120Vac, 60 Hz	DETECTOR FUNCTION	Peak (PK) Average (AV)
ENVIRONMENTAL CONDITIONS	25deg. C, 65%RH	TESTED BY	Charles Hsiao

ANTENNA POLARITY & TEST DISTANCE: HORIZONTAL AT 3 M										
FREQ. (MHz)	EMISSION LEVEL (dBuV/m)	READ LEVEL (dBuV)	LIMIT (dBuV/m)	MARGIN (dB)	ANTENNA FACTOR (dB/m)	CABLE LOSS (dB)	PREAMP FACTOR (dB)	ANTENNA HEIGHT (cm)	TABLE ANGLE (Degree)	REMARK
2386	39.87	37.79	54	-14.13	31.8	5.77	35.49	126	177	Average
2386	56.75	54.67	74	-17.25	31.8	5.77	35.49	126	177	Peak
2437	94.69	92.46			31.85	5.84	35.46	126	177	Average
2437	97.33	95.1			31.85	5.84	35.46	126	177	Peak
2500	40.33	37.91	54	-13.67	31.9	5.93	35.41	126	177	Average
2500	56.69	54.27	74	-17.31	31.9	5.93	35.41	126	177	Peak

ANTENNA POLARITY & TEST DISTANCE: VERTICAL AT 3 M										
FREQ. (MHz)	EMISSION LEVEL (dBuV/m)	READ LEVEL (dBuV)	LIMIT (dBuV/m)	MARGIN (dB)	ANTENNA FACTOR (dB/m)	CABLE LOSS (dB)	PREAMP FACTOR (dB)	ANTENNA HEIGHT (cm)	TABLE ANGLE (Degree)	REMARK
2386	40.57	38.49	54	-13.43	31.8	5.77	35.49	102	161	Average
2386	55.97	53.89	74	-18.03	31.8	5.77	35.49	102	161	Peak
2437	98.29	96.06			31.85	5.84	35.46	102	161	Average
2437	100.86	98.63			31.85	5.84	35.46	102	161	Peak
2500	40.53	38.11	54	-13.47	31.9	5.93	35.41	102	161	Average
2500	56.22	53.8	74	-17.78	31.9	5.93	35.41	102	161	Peak

**REMARKS:**

- Emission Level = Read Level + Antenna Factor + Cable Loss - Preamp Factor  
Margin value = Emission level – Limit value
- 2437MHz: Fundamental frequency.



A D T

EUT TEST CONDITION		MEASUREMENT DETAIL	
CHANNEL	Channel 11	FREQUENCY RANGE	1GHz ~ 25GHz
INPUT POWER	120Vac, 60 Hz	DETECTOR FUNCTION	Peak (PK) Average (AV)
ENVIRONMENTAL CONDITIONS	25deg. C, 65%RH	TESTED BY	Charles Hsiao

ANTENNA POLARITY & TEST DISTANCE: HORIZONTAL AT 3 M										
FREQ. (MHz)	EMISSION LEVEL (dBuV/m)	READ LEVEL (dBuV)	LIMIT (dBuV/m)	MARGIN (dB)	ANTENNA FACTOR (dB/m)	CABLE LOSS (dB)	PREAMP FACTOR (dB)	ANTENNA HEIGHT (cm)	TABLE ANGLE (Degree)	REMARK
2340	39.79	37.81	54	-14.21	31.74	5.74	35.5	125	177	Average
2340	55.19	53.21	74	-18.81	31.74	5.74	35.5	125	177	Peak
2462	94.23	91.93			31.87	5.87	35.44	125	177	Average
2462	97.1	94.8			31.87	5.87	35.44	125	177	Peak
2492	40.63	38.21	54	-13.37	31.9	5.93	35.41	125	177	Average
2492	56.09	53.67	74	-17.91	31.9	5.93	35.41	125	177	Peak

ANTENNA POLARITY & TEST DISTANCE: VERTICAL AT 3 M										
FREQ. (MHz)	EMISSION LEVEL (dBuV/m)	READ LEVEL (dBuV)	LIMIT (dBuV/m)	MARGIN (dB)	ANTENNA FACTOR (dB/m)	CABLE LOSS (dB)	PREAMP FACTOR (dB)	ANTENNA HEIGHT (cm)	TABLE ANGLE (Degree)	REMARK
2360	40.11	38.11	54	-13.89	31.76	5.74	35.5	101	157	Average
2360	55.28	53.28	74	-18.72	31.76	5.74	35.5	101	157	Peak
2462	97.53	95.23			31.87	5.87	35.44	101	157	Average
2462	100.34	98.04			31.87	5.87	35.44	101	157	Peak
2498	41.13	38.71	54	-12.87	31.9	5.93	35.41	101	157	Average
2498	55.35	52.93	74	-18.65	31.9	5.93	35.41	101	157	Peak

**REMARKS:**

- Emission Level = Read Level + Antenna Factor + Cable Loss - Preamp Factor  
Margin value = Emission level – Limit value
- 2462MHz: Fundamental frequency.



A D T

802.11g

EUT TEST CONDITION		MEASUREMENT DETAIL	
CHANNEL	Channel 1	FREQUENCY RANGE	1GHz ~ 25GHz
INPUT POWER	120Vac, 60 Hz	DETECTOR FUNCTION	Peak (PK) Average (AV)
ENVIRONMENTAL CONDITIONS	25deg. C, 65%RH	TESTED BY	Charles Hsiao

ANTENNA POLARITY & TEST DISTANCE: HORIZONTAL AT 3 M										
FREQ. (MHz)	EMISSION LEVEL (dBuV/m)	READ LEVEL (dBuV)	LIMIT (dBuV/m)	MARGIN (dB)	ANTENNA FACTOR (dB/m)	CABLE LOSS (dB)	PREAMP FACTOR (dB)	ANTENNA HEIGHT (cm)	TABLE ANGLE (Degree)	REMARK
2388	47.3	45.18	54	-6.7	31.8	5.81	35.49	111	177	Average
2388	62.04	59.92	74	-11.96	31.8	5.81	35.49	111	177	Peak
2412	92.32	90.17			31.81	5.81	35.47	111	177	Average
2412	100.83	98.68			31.81	5.81	35.47	111	177	Peak
2494	41.33	38.91	54	-12.67	31.9	5.93	35.41	111	177	Average
2494	55.34	52.92	74	-18.66	31.9	5.93	35.41	111	177	Peak
ANTENNA POLARITY & TEST DISTANCE: VERTICAL AT 3 M										
FREQ. (MHz)	EMISSION LEVEL (dBuV/m)	READ LEVEL (dBuV)	LIMIT (dBuV/m)	MARGIN (dB)	ANTENNA FACTOR (dB/m)	CABLE LOSS (dB)	PREAMP FACTOR (dB)	ANTENNA HEIGHT (cm)	TABLE ANGLE (Degree)	REMARK
2390	49.8	47.66	54	-4.2	31.8	5.81	35.47	103	161	Average
2390	65.34	63.2	74	-8.66	31.8	5.81	35.47	103	161	Peak
2412	94.52	92.37			31.81	5.81	35.47	103	161	Average
2412	102.64	100.49			31.81	5.81	35.47	103	161	Peak
2484	41.98	39.62	54	-12.02	31.88	5.9	35.42	103	161	Average
2484	55.54	53.18	74	-18.46	31.88	5.9	35.42	103	161	Peak

REMARKS:

- Emission Level = Read Level + Antenna Factor + Cable Loss - Preamp Factor  
Margin value = Emission level – Limit value
- 2412MHz: Fundamental frequency.



A D T

EUT TEST CONDITION		MEASUREMENT DETAIL	
CHANNEL	Channel 6	FREQUENCY RANGE	1GHz ~ 25GHz
INPUT POWER	120Vac, 60 Hz	DETECTOR FUNCTION	Peak (PK) Average (AV)
ENVIRONMENTAL CONDITIONS	25deg. C, 65%RH	TESTED BY	Charles Hsiao

ANTENNA POLARITY & TEST DISTANCE: HORIZONTAL AT 3 M										
FREQ. (MHz)	EMISSION LEVEL (dBuV/m)	READ LEVEL (dBuV)	LIMIT (dBuV/m)	MARGIN (dB)	ANTENNA FACTOR (dB/m)	CABLE LOSS (dB)	PREAMP FACTOR (dB)	ANTENNA HEIGHT (cm)	TABLE ANGLE (Degree)	REMARK
2386	42.07	39.99	54	-11.93	31.8	5.77	35.49	126	177	Average
2386	55.61	53.53	74	-18.39	31.8	5.77	35.49	126	177	Peak
2437	92.19	89.96			31.85	5.84	35.46	126	177	Average
2437	100.22	97.99			31.85	5.84	35.46	126	177	Peak
2484	41.88	39.52	54	-12.12	31.88	5.9	35.42	126	177	Average
2484	56.03	53.67	74	-17.97	31.88	5.9	35.42	126	177	Peak

ANTENNA POLARITY & TEST DISTANCE: VERTICAL AT 3 M										
FREQ. (MHz)	EMISSION LEVEL (dBuV/m)	READ LEVEL (dBuV)	LIMIT (dBuV/m)	MARGIN (dB)	ANTENNA FACTOR (dB/m)	CABLE LOSS (dB)	PREAMP FACTOR (dB)	ANTENNA HEIGHT (cm)	TABLE ANGLE (Degree)	REMARK
2384	43.55	41.49	54	-10.45	31.78	5.77	35.49	102	161	Average
2384	56.56	54.5	74	-17.44	31.78	5.77	35.49	102	161	Peak
2437	94.39	92.16			31.85	5.84	35.46	102	161	Average
2437	102.03	99.8			31.85	5.84	35.46	102	161	Peak
2484	43.18	40.82	54	-10.82	31.88	5.9	35.42	102	161	Average
2484	56.66	54.3	74	-17.34	31.88	5.9	35.42	102	161	Peak

**REMARKS:**

- Emission Level = Read Level + Antenna Factor + Cable Loss - Preamp Factor  
Margin value = Emission level – Limit value
- 2437MHz: Fundamental frequency.



A D T

EUT TEST CONDITION		MEASUREMENT DETAIL	
CHANNEL	Channel 11	FREQUENCY RANGE	1GHz ~ 25GHz
INPUT POWER	120Vac, 60 Hz	DETECTOR FUNCTION	Peak (PK) Average (AV)
ENVIRONMENTAL CONDITIONS	25deg. C, 65%RH	TESTED BY	Charles Hsiao

ANTENNA POLARITY & TEST DISTANCE: HORIZONTAL AT 3 M										
FREQ. (MHz)	EMISSION LEVEL (dBuV/m)	READ LEVEL (dBuV)	LIMIT (dBuV/m)	MARGIN (dB)	ANTENNA FACTOR (dB/m)	CABLE LOSS (dB)	PREAMP FACTOR (dB)	ANTENNA HEIGHT (cm)	TABLE ANGLE (Degree)	REMARK
2332	40.94	39.02	54	-13.06	31.73	5.71	35.52	125	177	Average
2332	55.59	53.67	74	-18.41	31.73	5.71	35.52	125	177	Peak
2462	92.33	90.03			31.87	5.87	35.44	125	177	Average
2462	100.21	97.91			31.87	5.87	35.44	125	177	Peak
2484	45.88	43.52	54	-8.12	31.88	5.9	35.42	125	177	Average
2484	62.9	60.54	74	-11.1	31.88	5.9	35.42	125	177	Peak

ANTENNA POLARITY & TEST DISTANCE: VERTICAL AT 3 M										
FREQ. (MHz)	EMISSION LEVEL (dBuV/m)	READ LEVEL (dBuV)	LIMIT (dBuV/m)	MARGIN (dB)	ANTENNA FACTOR (dB/m)	CABLE LOSS (dB)	PREAMP FACTOR (dB)	ANTENNA HEIGHT (cm)	TABLE ANGLE (Degree)	REMARK
2384	42.05	39.99	54	-11.95	31.78	5.77	35.49	100	161	Average
2384	55.33	53.27	74	-18.67	31.78	5.77	35.49	100	161	Peak
2462	94.73	92.43			31.87	5.87	35.44	100	161	Average
2462	102.84	100.54			31.87	5.87	35.44	100	161	Peak
2484	49.28	46.92	54	-4.72	31.88	5.9	35.42	100	161	Average
2484	67.23	64.87	74	-6.77	31.88	5.9	35.42	100	161	Peak

**REMARKS:**

- Emission Level = Read Level + Antenna Factor + Cable Loss - Preamp Factor  
Margin value = Emission level – Limit value
- 2462MHz: Fundamental frequency.





A D T

## 802.11n (20MHz)

EUT TEST CONDITION		MEASUREMENT DETAIL	
CHANNEL	Channel 1	FREQUENCY RANGE	1GHz ~ 25GHz
INPUT POWER	120Vac, 60 Hz	DETECTOR FUNCTION	Peak (PK) Average (AV)
ENVIRONMENTAL CONDITIONS	25deg. C, 65%RH	TESTED BY	Charles Hsiao

ANTENNA POLARITY & TEST DISTANCE: HORIZONTAL AT 3 M										
FREQ. (MHz)	EMISSION LEVEL (dBuV/m)	READ LEVEL (dBuV)	LIMIT (dBuV/m)	MARGIN (dB)	ANTENNA FACTOR (dB/m)	CABLE LOSS (dB)	PREAMP FACTOR (dB)	ANTENNA HEIGHT (cm)	TABLE ANGLE (Degree)	REMARK
2390	47.7	45.56	54	-6.3	31.8	5.81	35.47	111	177	Average
2390	65.82	63.68	74	-8.18	31.8	5.81	35.47	111	177	Peak
2412	92.12	89.97			31.81	5.81	35.47	111	177	Average
2412	100.17	98.02			31.81	5.81	35.47	111	177	Peak
2484	41.28	38.92	54	-12.72	31.88	5.9	35.42	111	177	Average
2484	56.03	53.67	74	-17.97	31.88	5.9	35.42	111	177	Peak

ANTENNA POLARITY & TEST DISTANCE: VERTICAL AT 3 M										
FREQ. (MHz)	EMISSION LEVEL (dBuV/m)	READ LEVEL (dBuV)	LIMIT (dBuV/m)	MARGIN (dB)	ANTENNA FACTOR (dB/m)	CABLE LOSS (dB)	PREAMP FACTOR (dB)	ANTENNA HEIGHT (cm)	TABLE ANGLE (Degree)	REMARK
2388	50.3	48.18	54	-3.7	31.8	5.81	35.49	103	161	Average
2388	65.25	63.13	74	-8.75	31.8	5.81	35.49	103	161	Peak
2412	94.12	91.97			31.81	5.81	35.47	103	161	Average
2412	102.46	100.31			31.81	5.81	35.47	103	161	Peak
2494	41.93	39.51	54	-12.07	31.9	5.93	35.41	103	161	Average
2494	55.87	53.45	74	-18.13	31.9	5.93	35.41	103	161	Peak

## REMARKS:

- Emission Level = Read Level + Antenna Factor + Cable Loss - Preamp Factor  
Margin value = Emission level – Limit value
- 2412MHz: Fundamental frequency.



A D T

EUT TEST CONDITION		MEASUREMENT DETAIL	
CHANNEL	Channel 6	FREQUENCY RANGE	1GHz ~ 25GHz
INPUT POWER	120Vac, 60 Hz	DETECTOR FUNCTION	Peak (PK) Average (AV)
ENVIRONMENTAL CONDITIONS	25deg. C, 65%RH	TESTED BY	Charles Hsiao

ANTENNA POLARITY & TEST DISTANCE: HORIZONTAL AT 3 M										
FREQ. (MHz)	EMISSION LEVEL (dBuV/m)	READ LEVEL (dBuV)	LIMIT (dBuV/m)	MARGIN (dB)	ANTENNA FACTOR (dB/m)	CABLE LOSS (dB)	PREAMP FACTOR (dB)	ANTENNA HEIGHT (cm)	TABLE ANGLE (Degree)	REMARK
2344	41.89	39.91	54	-12.11	31.74	5.74	35.5	126	177	Average
2344	55.62	53.64	74	-18.38	31.74	5.74	35.5	126	177	Peak
2437	92.69	90.46			31.85	5.84	35.46	126	177	Average
2437	100.33	98.1			31.85	5.84	35.46	126	177	Peak
2488	41.83	39.42	54	-12.17	31.9	5.93	35.42	126	177	Average
2488	55.94	53.53	74	-18.06	31.9	5.93	35.42	126	177	Peak

ANTENNA POLARITY & TEST DISTANCE: VERTICAL AT 3 M										
FREQ. (MHz)	EMISSION LEVEL (dBuV/m)	READ LEVEL (dBuV)	LIMIT (dBuV/m)	MARGIN (dB)	ANTENNA FACTOR (dB/m)	CABLE LOSS (dB)	PREAMP FACTOR (dB)	ANTENNA HEIGHT (cm)	TABLE ANGLE (Degree)	REMARK
2390	43.4	41.26	54	-10.6	31.8	5.81	35.47	102	161	Average
2390	56.23	54.09	74	-17.77	31.8	5.81	35.47	102	161	Peak
2437	94.69	92.46			31.85	5.84	35.46	102	161	Average
2437	102.44	100.21			31.85	5.84	35.46	102	161	Peak
2496	43.13	40.71	54	-10.87	31.9	5.93	35.41	102	161	Average
2496	56.28	53.86	74	-17.72	31.9	5.93	35.41	102	161	Peak

**REMARKS:**

- Emission Level = Read Level + Antenna Factor + Cable Loss - Preamp Factor  
Margin value = Emission level – Limit value
- 2437MHz: Fundamental frequency.



A D T

EUT TEST CONDITION		MEASUREMENT DETAIL	
CHANNEL	Channel 11	FREQUENCY RANGE	1GHz ~ 25GHz
INPUT POWER	120Vac, 60 Hz	DETECTOR FUNCTION	Peak (PK) Average (AV)
ENVIRONMENTAL CONDITIONS	25deg. C, 65%RH	TESTED BY	Charles Hsiao

ANTENNA POLARITY & TEST DISTANCE: HORIZONTAL AT 3 M										
FREQ. (MHz)	EMISSION LEVEL (dBuV/m)	READ LEVEL (dBuV)	LIMIT (dBuV/m)	MARGIN (dB)	ANTENNA FACTOR (dB/m)	CABLE LOSS (dB)	PREAMP FACTOR (dB)	ANTENNA HEIGHT (cm)	TABLE ANGLE (Degree)	REMARK
2368	41.04	39	54	-12.96	31.76	5.77	35.49	125	177	Average
2368	55.76	53.72	74	-18.24	31.76	5.77	35.49	125	177	Peak
2462	92.13	89.83			31.87	5.87	35.44	125	177	Average
2462	100.63	98.33			31.87	5.87	35.44	125	177	Peak
2484	46.73	44.37	54	-7.27	31.88	5.9	35.42	125	177	Average
2484	60.63	58.27	74	-13.37	31.88	5.9	35.42	125	177	Peak

ANTENNA POLARITY & TEST DISTANCE: VERTICAL AT 3 M										
FREQ. (MHz)	EMISSION LEVEL (dBuV/m)	READ LEVEL (dBuV)	LIMIT (dBuV/m)	MARGIN (dB)	ANTENNA FACTOR (dB/m)	CABLE LOSS (dB)	PREAMP FACTOR (dB)	ANTENNA HEIGHT (cm)	TABLE ANGLE (Degree)	REMARK
2384	41.65	39.59	54	-12.35	31.78	5.77	35.49	100	161	Average
2384	56.22	54.16	74	-17.78	31.78	5.77	35.49	100	161	Peak
2462	94.33	92.03			31.87	5.87	35.44	100	161	Average
2462	102.78	100.48			31.87	5.87	35.44	100	161	Peak
2486	49.93	47.57	54	-4.07	31.88	5.9	35.42	100	161	Average
2486	64.67	62.31	74	-9.33	31.88	5.9	35.42	100	161	Peak

**REMARKS:**

- Emission Level = Read Level + Antenna Factor + Cable Loss - Preamp Factor  
Margin value = Emission level – Limit value
- 2462MHz: Fundamental frequency.



A D T

802.11n (40MHz)

EUT TEST CONDITION		MEASUREMENT DETAIL	
CHANNEL	Channel 3	FREQUENCY RANGE	1GHz ~ 25GHz
INPUT POWER	120Vac, 60 Hz	DETECTOR FUNCTION	Peak (PK) Average (AV)
ENVIRONMENTAL CONDITIONS	25deg. C, 65%RH	TESTED BY	Charles Hsiao

ANTENNA POLARITY & TEST DISTANCE: HORIZONTAL AT 3 M										
FREQ. (MHz)	EMISSION LEVEL (dBuV/m)	READ LEVEL (dBuV)	LIMIT (dBuV/m)	MARGIN (dB)	ANTENNA FACTOR (dB/m)	CABLE LOSS (dB)	PREAMP FACTOR (dB)	ANTENNA HEIGHT (cm)	TABLE ANGLE (Degree)	REMARK
2388	49.9	47.78	54	-4.1	31.8	5.81	35.49	111	177	Average
2388	67.09	64.97	74	-6.91	31.8	5.81	35.49	111	177	Peak
2422	90.17	87.96			31.83	5.84	35.46	111	177	Average
2422	98.3	96.09			31.83	5.84	35.46	111	177	Peak
2484	42.48	40.12	54	-11.52	31.88	5.9	35.42	111	177	Average
2484	55.58	53.22	74	-18.42	31.88	5.9	35.42	111	177	Peak
ANTENNA POLARITY & TEST DISTANCE: VERTICAL AT 3 M										
FREQ. (MHz)	EMISSION LEVEL (dBuV/m)	READ LEVEL (dBuV)	LIMIT (dBuV/m)	MARGIN (dB)	ANTENNA FACTOR (dB/m)	CABLE LOSS (dB)	PREAMP FACTOR (dB)	ANTENNA HEIGHT (cm)	TABLE ANGLE (Degree)	REMARK
2388	51	48.88	54	-3	31.8	5.81	35.49	103	148	Average
2388	67.83	65.71	74	-6.17	31.8	5.81	35.49	103	148	Peak
2422	91.87	89.66			31.83	5.84	35.46	103	148	Average
2422	100.31	98.1			31.83	5.84	35.46	103	148	Peak
2484	44.08	41.72	54	-9.92	31.88	5.9	35.42	103	148	Average
2484	61.21	58.85	74	-12.79	31.88	5.9	35.42	103	148	Peak

REMARKS:

- Emission Level = Read Level + Antenna Factor + Cable Loss - Preamp Factor  
Margin value = Emission level – Limit value
- 2422MHz: Fundamental frequency.



A D T

EUT TEST CONDITION		MEASUREMENT DETAIL	
CHANNEL	Channel 6	FREQUENCY RANGE	1GHz ~ 25GHz
INPUT POWER	120Vac, 60 Hz	DETECTOR FUNCTION	Peak (PK) Average (AV)
ENVIRONMENTAL CONDITIONS	25deg. C, 65%RH	TESTED BY	Charles Hsiao

ANTENNA POLARITY & TEST DISTANCE: HORIZONTAL AT 3 M										
FREQ. (MHz)	EMISSION LEVEL (dBuV/m)	READ LEVEL (dBuV)	LIMIT (dBuV/m)	MARGIN (dB)	ANTENNA FACTOR (dB/m)	CABLE LOSS (dB)	PREAMP FACTOR (dB)	ANTENNA HEIGHT (cm)	TABLE ANGLE (Degree)	REMARK
2384	45.3	43.24	54	-8.7	31.78	5.77	35.49	126	177	Average
2384	59.37	57.31	74	-14.63	31.78	5.77	35.49	126	177	Peak
2437	90.69	88.46			31.85	5.84	35.46	126	177	Average
2437	98.39	96.16			31.85	5.84	35.46	126	177	Peak
2492	46.98	44.56	54	-7.02	31.9	5.93	35.41	126	177	Average
2492	61.9	59.48	74	-12.1	31.9	5.93	35.41	126	177	Peak

ANTENNA POLARITY & TEST DISTANCE: VERTICAL AT 3 M										
FREQ. (MHz)	EMISSION LEVEL (dBuV/m)	READ LEVEL (dBuV)	LIMIT (dBuV/m)	MARGIN (dB)	ANTENNA FACTOR (dB/m)	CABLE LOSS (dB)	PREAMP FACTOR (dB)	ANTENNA HEIGHT (cm)	TABLE ANGLE (Degree)	REMARK
2390	49.1	46.96	54	-4.9	31.8	5.81	35.47	102	161	Average
2390	64.85	62.71	74	-9.15	31.8	5.81	35.47	102	161	Peak
2437	92.89	90.66			31.85	5.84	35.46	102	161	Average
2437	100.66	98.43			31.85	5.84	35.46	102	161	Peak
2488	50.98	48.57	54	-3.02	31.9	5.93	35.42	102	161	Average
2488	66.6	64.19	74	-7.4	31.9	5.93	35.42	102	161	Peak

**REMARKS:**

1. Emission Level = Read Level + Antenna Factor + Cable Loss - Preamp Factor  
Margin value = Emission level – Limit value
2. 2437MHz: Fundamental frequency.



A D T

EUT TEST CONDITION		MEASUREMENT DETAIL	
CHANNEL	Channel 9	FREQUENCY RANGE	1GHz ~ 25GHz
INPUT POWER	120Vac, 60 Hz	DETECTOR FUNCTION	Peak (PK) Average (AV)
ENVIRONMENTAL CONDITIONS	25deg. C, 65%RH	TESTED BY	Charles Hsiao

ANTENNA POLARITY & TEST DISTANCE: HORIZONTAL AT 3 M										
FREQ. (MHz)	EMISSION LEVEL (dBuV/m)	READ LEVEL (dBuV)	LIMIT (dBuV/m)	MARGIN (dB)	ANTENNA FACTOR (dB/m)	CABLE LOSS (dB)	PREAMP FACTOR (dB)	ANTENNA HEIGHT (cm)	TABLE ANGLE (Degree)	REMARK
2318	41.44	39.52	54	-12.56	31.73	5.71	35.52	125	177	Average
2318	55.96	54.04	74	-18.04	31.73	5.71	35.52	125	177	Peak
2452	90.62	88.34			31.85	5.87	35.44	125	177	Average
2452	98.61	96.33			31.85	5.87	35.44	125	177	Peak
2486	49.78	47.42	54	-4.22	31.88	5.9	35.42	125	177	Average
2486	63.08	60.72	74	-10.92	31.88	5.9	35.42	125	177	Peak

ANTENNA POLARITY & TEST DISTANCE: VERTICAL AT 3 M										
FREQ. (MHz)	EMISSION LEVEL (dBuV/m)	READ LEVEL (dBuV)	LIMIT (dBuV/m)	MARGIN (dB)	ANTENNA FACTOR (dB/m)	CABLE LOSS (dB)	PREAMP FACTOR (dB)	ANTENNA HEIGHT (cm)	TABLE ANGLE (Degree)	REMARK
2390	42.8	40.66	54	-11.2	31.8	5.81	35.47	100	161	Average
2390	56.44	54.3	74	-17.56	31.8	5.81	35.47	100	161	Peak
2452	92.23	89.95			31.85	5.87	35.44	100	161	Average
2452	100.28	98			31.85	5.87	35.44	100	161	Peak
2486	50.98	48.62	54	-3.02	31.88	5.9	35.42	100	161	Average
2486	66.05	63.69	74	-7.95	31.88	5.9	35.42	100	161	Peak

**REMARKS:**

1. Emission Level = Read Level + Antenna Factor + Cable Loss - Preamp Factor  
Margin value = Emission level – Limit value
2. 2452MHz: Fundamental frequency.



A D T

**MODE B**

**802.11n (40MHz)**

EUT TEST CONDITION		MEASUREMENT DETAIL	
CHANNEL	Channel 3	FREQUENCY RANGE	1GHz ~ 25GHz
INPUT POWER	120Vac, 60 Hz	DETECTOR FUNCTION	Peak (PK) Average (AV)
ENVIRONMENTAL CONDITIONS	25deg. C, 65%RH	TESTED BY	Karl Lee

ANTENNA POLARITY & TEST DISTANCE: HORIZONTAL AT 3 M										
FREQ. (MHz)	EMISSION LEVEL (dBuV/m)	READ LEVEL (dBuV)	LIMIT (dBuV/m)	MARGIN (dB)	ANTENNA FACTOR (dB/m)	CABLE LOSS (dB)	PREAMP FACTOR (dB)	ANTENNA HEIGHT (cm)	TABLE ANGLE (Degree)	REMARK
2388	48.33	46.62	54	-5.67	31.8	5.4	35.49	120	349	Average
2388	59.18	57.47	74	-14.82	31.8	5.4	35.49	120	349	Peak
2422	89.3	87.5			31.83	5.43	35.46	120	349	Average
2422	97.25	95.45			31.83	5.43	35.46	120	349	Peak
2500	42.97	40.95	54	-11.03	31.9	5.53	35.41	120	349	Average
2500	56.38	54.36	74	-17.62	31.9	5.53	35.41	120	349	Peak
ANTENNA POLARITY & TEST DISTANCE: VERTICAL AT 3 M										
FREQ. (MHz)	EMISSION LEVEL (dBuV/m)	READ LEVEL (dBuV)	LIMIT (dBuV/m)	MARGIN (dB)	ANTENNA FACTOR (dB/m)	CABLE LOSS (dB)	PREAMP FACTOR (dB)	ANTENNA HEIGHT (cm)	TABLE ANGLE (Degree)	REMARK
2390	50.94	49.21	54	-3.06	31.8	5.4	35.47	101	339	Average
2390	63.94	62.21	74	-10.06	31.8	5.4	35.47	101	339	Peak
2422	92.6	90.8			31.83	5.43	35.46	101	339	Average
2422	100.62	98.82			31.83	5.43	35.46	101	339	Peak
2486	43.59	41.6	54	-10.41	31.88	5.53	35.42	101	339	Average
2486	57.81	55.82	74	-16.19	31.88	5.53	35.42	101	339	Peak

**REMARKS:**

- Emission Level = Read Level + Antenna Factor + Cable Loss - Preamp Factor  
Margin value = Emission level – Limit value
- 2422MHz: Fundamental frequency.



A D T

**MODE C**

**802.11n (40MHz)**

EUT TEST CONDITION		MEASUREMENT DETAIL	
CHANNEL	Channel 3	FREQUENCY RANGE	1GHz ~ 25GHz
INPUT POWER	120Vac, 60 Hz	DETECTOR FUNCTION	Peak (PK) Average (AV)
ENVIRONMENTAL CONDITIONS	25deg. C, 65%RH	TESTED BY	Karl Lee

**ANTENNA POLARITY & TEST DISTANCE: HORIZONTAL AT 3 M**

FREQ. (MHz)	EMISSION LEVEL (dBuV/m)	READ LEVEL (dBuV)	LIMIT (dBuV/m)	MARGIN (dB)	ANTENNA FACTOR (dB/m)	CABLE LOSS (dB)	PREAMP FACTOR (dB)	ANTENNA HEIGHT (cm)	TABLE ANGLE (Degree)	REMARK
2386	50.29	48.58	54	-3.71	31.8	5.4	35.49	160	244	Average
2386	64	62.29	74	-10	31.8	5.4	35.49	160	244	Peak
2422	92.51	90.71			31.83	5.43	35.46	160	244	Average
2422	100.56	98.76			31.83	5.43	35.46	160	244	Peak
2500	42.59	40.57	54	-11.41	31.9	5.53	35.41	160	244	Average
2500	56.48	54.46	74	-17.52	31.9	5.53	35.41	160	244	Peak

**ANTENNA POLARITY & TEST DISTANCE: VERTICAL AT 3 M**

FREQ. (MHz)	EMISSION LEVEL (dBuV/m)	READ LEVEL (dBuV)	LIMIT (dBuV/m)	MARGIN (dB)	ANTENNA FACTOR (dB/m)	CABLE LOSS (dB)	PREAMP FACTOR (dB)	ANTENNA HEIGHT (cm)	TABLE ANGLE (Degree)	REMARK
2386	49	47.29	54	-5	31.8	5.4	35.49	116	171	Average
2386	61	59.29	74	-13	31.8	5.4	35.49	116	171	Peak
2422	90.93	89.13			31.83	5.43	35.46	116	171	Average
2422	98.52	96.72			31.83	5.43	35.46	116	171	Peak
2484	42	40.04	54	-12	31.88	5.5	35.42	116	171	Average
2484	56.01	54.05	74	-17.99	31.88	5.5	35.42	116	171	Peak

**REMARKS:**

- Emission Level = Read Level + Antenna Factor + Cable Loss - Preamp Factor  
Margin value = Emission level – Limit value
- 2422MHz: Fundamental frequency.





A D T

**BELOW 1GHz WORST-CASE DATA:**

**MODE A**

**802.11n (40MHz)**

EUT TEST CONDITION		MEASUREMENT DETAIL	
CHANNEL	Channel 3	FREQUENCY RANGE	30MHz ~ 1GHz
INPUT POWER	120Vac, 60 Hz	DETECTOR FUNCTION	Peak (PK) Quasi-peak (QP)
ENVIRONMENTAL CONDITIONS	25deg. C, 65%RH	TESTED BY	Harry Hsueh

**ANTENNA POLARITY & TEST DISTANCE: HORIZONTAL AT 3 M**

FREQ. (MHz)	EMISSION LEVEL (dBuV/m)	READ LEVEL (dBuV)	LIMIT (dBuV/m)	MARGIN (dB)	ANTENNA FACTOR (dB/m)	CABLE LOSS (dB)	PREAMP FACTOR (dB)	ANTENNA HEIGHT (cm)	TABLE ANGLE (Degree)	REMARK
86.43	28.97	51.04	40	-11.03	8.73	1.11	31.91	104	124	Peak
112.62	31.27	53.02	43.5	-12.23	9.22	1.28	32.25	155	125	Peak
231.69	23.24	41.37	46	-22.76	12.19	1.85	32.17	165	144	Peak
454	20.26	31.73	46	-25.74	18.18	2.49	32.14	185	145	Peak
683.6	24.11	29.9	46	-21.89	23.27	3.05	32.11	104	135	Peak
798.4	25.47	29.79	46	-20.53	24.42	3.32	32.06	176	225	Peak

**ANTENNA POLARITY & TEST DISTANCE: VERTICAL AT 3 M**

FREQ. (MHz)	EMISSION LEVEL (dBuV/m)	READ LEVEL (dBuV)	LIMIT (dBuV/m)	MARGIN (dB)	ANTENNA FACTOR (dB/m)	CABLE LOSS (dB)	PREAMP FACTOR (dB)	ANTENNA HEIGHT (cm)	TABLE ANGLE (Degree)	REMARK
84.54	31.04	53.3	40	-8.96	8.64	1.11	32.01	185	168	Peak
134.49	23.01	44.63	43.5	-20.49	9.25	1.38	32.25	163	125	Peak
246.27	19.31	36.74	46	-26.69	12.83	1.85	32.11	170	166	Peak
519.1	20.94	30.05	46	-25.06	20.32	2.7	32.13	155	142	Peak
668.2	23.73	29.63	46	-22.27	23.18	3.05	32.13	139	226	Peak
779.5	25.76	30.9	46	-20.24	23.68	3.27	32.09	178	238	Peak

**REMARKS:** Emission Level = Read Level + Antenna Factor + Cable Loss - Preamp Factor

Margin value = Emission level – Limit value



A D T

**MODE B**

**802.11n (40MHz)**

EUT TEST CONDITION		MEASUREMENT DETAIL	
CHANNEL	Channel 3	FREQUENCY RANGE	30MHz ~ 1GHz
INPUT POWER	120Vac, 60 Hz	DETECTOR FUNCTION	Peak (PK) Quasi-peak (QP)
ENVIRONMENTAL CONDITIONS	25deg. C, 65%RH	TESTED BY	Charles Hsiao

ANTENNA POLARITY & TEST DISTANCE: HORIZONTAL AT 3 M										
FREQ. (MHz)	EMISSION LEVEL (dBuV/m)	READ LEVEL (dBuV)	LIMIT (dBuV/m)	MARGIN (dB)	ANTENNA FACTOR (dB/m)	CABLE LOSS (dB)	PREAMP FACTOR (dB)	ANTENNA HEIGHT (cm)	TABLE ANGLE (Degree)	REMARK
79.41	15.91	38.63	40	-24.09	8.38	1.11	32.21	165	198	Peak
121.8	22.33	44.39	43.5	-21.17	8.8	1.38	32.24	114	175	Peak
188.49	19.74	39.98	43.5	-23.76	10.4	1.61	32.25	102	145	Peak
415.5	18.14	30.08	46	-27.86	17.85	2.41	32.2	112	198	Peak
605.2	21.79	29.87	46	-24.21	21.24	2.87	32.19	173	185	Peak
794.2	26.08	30.65	46	-19.92	24.23	3.27	32.07	111	203	Peak

ANTENNA POLARITY & TEST DISTANCE: VERTICAL AT 3 M										
FREQ. (MHz)	EMISSION LEVEL (dBuV/m)	READ LEVEL (dBuV)	LIMIT (dBuV/m)	MARGIN (dB)	ANTENNA FACTOR (dB/m)	CABLE LOSS (dB)	PREAMP FACTOR (dB)	ANTENNA HEIGHT (cm)	TABLE ANGLE (Degree)	REMARK
31.35	36.04	50.74	40	-3.96	16.82	0.74	32.26	158	142	QP
79.95	18.67	41.38	40	-21.33	8.39	1.11	32.21	177	285	Peak
188.76	14.57	34.81	43.5	-28.93	10.4	1.61	32.25	116	265	Peak
465.9	18.76	29.79	46	-27.24	18.54	2.56	32.13	195	176	Peak
634.6	23.16	30.29	46	-22.84	22.1	2.93	32.16	143	188	Peak
808.9	25.89	30.42	46	-20.11	24.16	3.32	32.01	107	148	Peak

**REMARKS:** Emission Level = Read Level + Antenna Factor + Cable Loss - Preamp Factor  
Margin value = Emission level – Limit value



A D T

**MODE C**

**802.11n (40MHz)**

EUT TEST CONDITION		MEASUREMENT DETAIL	
CHANNEL	Channel 3	FREQUENCY RANGE	30MHz ~ 1GHz
INPUT POWER	120Vac, 60 Hz	DETECTOR FUNCTION	Peak (PK) Quasi-peak (QP)
ENVIRONMENTAL CONDITIONS	25deg. C, 65%RH	TESTED BY	Charles Hsiao

ANTENNA POLARITY & TEST DISTANCE: HORIZONTAL AT 3 M										
FREQ. (MHz)	EMISSION LEVEL (dBuV/m)	READ LEVEL (dBuV)	LIMIT (dBuV/m)	MARGIN (dB)	ANTENNA FACTOR (dB/m)	CABLE LOSS (dB)	PREAMP FACTOR (dB)	ANTENNA HEIGHT (cm)	TABLE ANGLE (Degree)	REMARK
79.41	15.91	38.63	40	-24.09	8.38	1.11	32.21	158	175	Peak
121.8	22.33	44.39	43.5	-21.17	8.8	1.38	32.24	165	123	Peak
188.49	19.74	39.98	43.5	-23.76	10.4	1.61	32.25	155	142	Peak
415.5	18.14	30.08	46	-27.86	17.85	2.41	32.2	159	175	Peak
533.8	21.21	30.11	46	-24.79	20.57	2.7	32.17	123	201	Peak
794.2	26.08	30.65	46	-19.92	24.23	3.27	32.07	112	198	Peak
ANTENNA POLARITY & TEST DISTANCE: VERTICAL AT 3 M										
FREQ. (MHz)	EMISSION LEVEL (dBuV/m)	READ LEVEL (dBuV)	LIMIT (dBuV/m)	MARGIN (dB)	ANTENNA FACTOR (dB/m)	CABLE LOSS (dB)	PREAMP FACTOR (dB)	ANTENNA HEIGHT (cm)	TABLE ANGLE (Degree)	REMARK
30.54	37.95	52.16	40	-2.05	17.31	0.74	32.26	157	184	QP
62.4	20.73	44.94	40	-19.27	7.12	0.9	32.23	142	350	Peak
188.76	14.57	34.81	43.5	-28.93	10.4	1.61	32.25	142	298	Peak
416.9	17.97	29.95	46	-28.03	17.81	2.41	32.2	147	185	Peak
634.6	23.16	30.29	46	-22.84	22.1	2.93	32.16	165	195	Peak
852.3	26.1	30.64	46	-19.9	23.8	3.44	31.78	144	185	Peak

**REMARKS:** Emission Level = Read Level + Antenna Factor + Cable Loss - Preamp Factor  
Margin value = Emission level – Limit value

## 4.2 CONDUCTED EMISSION MEASUREMENT

### 4.2.1 LIMITS OF CONDUCTED EMISSION MEASUREMENT

FREQUENCY OF EMISSION (MHz)	CONDUCTED LIMIT (dB $\mu$ V)	
	Quasi-peak	Average
0.15 ~ 0.5	66 to 56	56 to 46
0.5 ~ 5	56	46
5 ~ 30	60	50

- NOTE:**
1. The lower limit shall apply at the transition frequencies.
  2. The limit decreases in line with the logarithm of the frequency in the range of 0.15 to 0.50MHz.
  3. All emanations from a class A/B digital device or system, including any network of conductors and apparatus connected thereto, shall not exceed the level of field strengths specified above.

### 4.2.2 TEST INSTRUMENTS

DESCRIPTION & MANUFACTURER	MODEL NO.	SERIAL NO.	DATE OF CALIBRATION	DUE DATE OF CALIBRATION
Test Receiver ROHDE & SCHWARZ	ESCS30	100288	Apr. 27, 2015	Apr. 26, 2016
RF signal cable Woken	5D-FB	Cable-HYCO2-01	Dec. 26, 2014	Dec. 25, 2015
LISN ROHDE & SCHWARZ (EUT)	ESH2-Z5	100100	Dec. 30, 2014	Dec. 29, 2015
LISN ROHDE & SCHWARZ (Peripheral)	ESH3-Z5	100312	Jul. 21, 2015	Jul. 20, 2016
Software ADT	BV ADT_Cond_ V7.3.7.3	NA	NA	NA

- NOTE:**
1. The calibration interval of the above test instruments is 12 months and the calibrations are traceable to NML/ROC and NIST/USA.
  2. The test was performed in HwaYa Shielded Room 1.
  3. The VCCI Site Registration No. is C-2040.

#### 4.2.3 TEST PROCEDURES

- a. The EUT was placed 0.4 meters from the conducting wall of the shielded room with EUT being connected to the power mains through a line impedance stabilization network (LISN). Other support units were connected to the power mains through another LISN. The two LISNs provide 50 ohm/ 50uH of coupling impedance for the measuring instrument.
- b. Both lines of the power mains connected to the EUT were checked for maximum conducted interference.
- c. The frequency range from 150kHz to 30MHz was searched. Emission levels under (Limit - 20dB) was not recorded.

**NOTE:** All modes of operation were investigated and the worst-case emissions are reported.

#### 4.2.4 DEVIATION FROM TEST STANDARD

No deviation.

#### 4.2.5 TEST SETUP

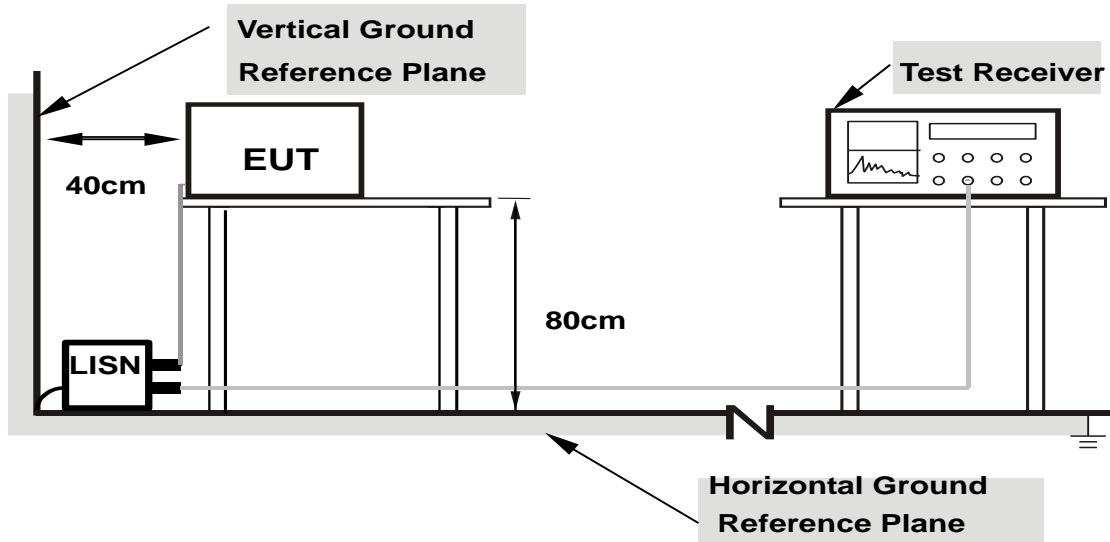

- Note:**
1. Support units were connected to second LISN.
  2. Both of LISNs (AMN) are 80 cm from EUT and at least 80 from other units and other metal planes

For the actual test configuration, please refer to the attached file (Test Setup Photo).

#### 4.2.6 EUT OPERATING CONDITIONS

Same as section 4.1.6.

**4.2.7 TEST RESULTS**

**CONDUCTED WORST-CASE DATA :**

**MODE A**

<b>PHASE</b>	Line 1	<b>6dB BANDWIDTH</b>	9kHz
--------------	--------	----------------------	------

Phase Of Power : Neutral (N)										
No	Frequency (MHz)	Correction Factor (dB)	Reading Value (dBuV)		Emission Level (dBuV)		Limit (dBuV)		Margin (dB)	
			Q.P.	AV.	Q.P.	AV.	Q.P.	AV.	Q.P.	AV.
1	0.18600	0.06	45.35	23.06	45.41	23.12	64.21	54.21	-18.81	-31.10
2	0.24200	0.06	42.47	33.90	42.53	33.96	62.03	52.03	-19.50	-18.07
3	0.29000	0.06	42.60	26.02	42.66	26.08	60.52	50.52	-17.86	-24.44
4	0.62200	0.07	22.59	16.47	22.66	16.54	56.00	46.00	-33.34	-29.46
5	1.04600	0.08	25.23	18.47	25.31	18.55	56.00	46.00	-30.69	-27.45
6	1.87800	0.12	37.10	29.80	37.22	29.92	56.00	46.00	-18.78	-16.08

Remarks:

1. Q.P. and AV. are abbreviations of quasi-peak and average individually.
2. The emission levels of other frequencies were very low against the limit.
3. Margin value = Emission level – Limit value
4. Correction factor = Insertion loss + Cable loss
5. Emission Level = Correction Factor + Reading Value

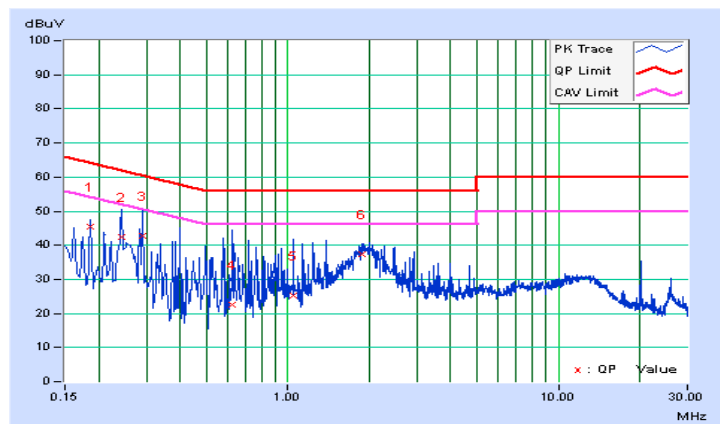



A D T

<b>PHASE</b>	Line 2	<b>6dB BANDWIDTH</b>	9kHz
--------------	--------	----------------------	------

Phase Of Power : Neutral (N)										
No	Frequency (MHz)	Correction Factor (dB)	Reading Value (dBuV)		Emission Level (dBuV)		Limit (dBuV)		Margin (dB)	
			Q.P.	AV.	Q.P.	AV.	Q.P.	AV.	Q.P.	AV.
1	0.19400	0.05	39.49	23.14	39.54	23.19	63.86	53.86	-24.32	-30.67
2	0.21805	0.05	38.15	28.41	38.20	28.46	62.89	52.89	-24.69	-24.43
3	0.26429	0.05	41.76	36.74	41.81	36.79	61.30	51.30	-19.48	-14.50
4	0.33062	0.06	34.96	24.21	35.02	24.27	59.44	49.44	-24.42	-25.17
5	0.38200	0.06	34.60	20.34	34.66	20.40	58.24	48.24	-23.58	-27.84
6	1.95000	0.11	38.99	34.24	39.10	34.35	56.00	46.00	-16.90	-11.65

Remarks:

1. Q.P. and AV. are abbreviations of quasi-peak and average individually.
2. The emission levels of other frequencies were very low against the limit.
3. Margin value = Emission level – Limit value
4. Correction factor = Insertion loss + Cable loss
5. Emission Level = Correction Factor + Reading Value

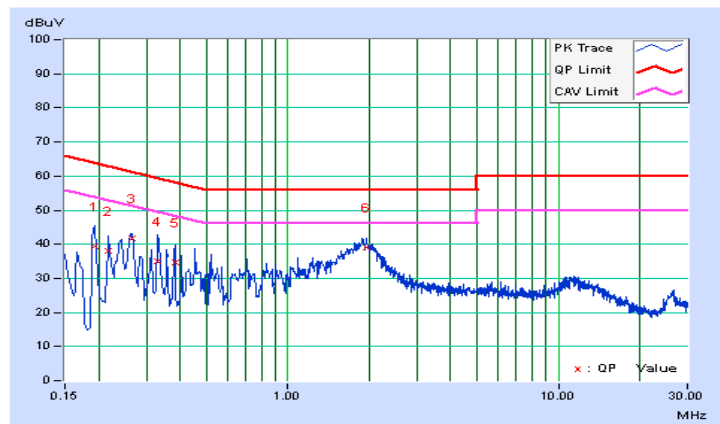





A D T

**MODE B**

<b>PHASE</b>	Line 1	<b>6dB BANDWIDTH</b>	9kHz
--------------	--------	----------------------	------

Phase Of Power : Neutral (N)										
No	Frequency (MHz)	Correction Factor (dB)	Reading Value (dBuV)		Emission Level (dBuV)		Limit (dBuV)		Margin (dB)	
			Q.P.	AV.	Q.P.	AV.	Q.P.	AV.	Q.P.	AV.
1	0.15604	0.05	53.32	29.24	53.37	29.29	65.67	55.67	-12.30	-26.38
2	0.17801	0.06	46.46	29.15	46.52	29.21	64.58	54.58	-18.06	-25.37
3	0.22600	0.06	42.60	26.83	42.66	26.89	62.60	52.60	-19.94	-25.71
4	0.34577	0.06	38.20	24.04	38.26	24.10	59.06	49.06	-20.80	-24.96
5	0.39000	0.06	37.07	23.79	37.13	23.85	58.06	48.06	-20.93	-24.21
6	1.89400	0.12	41.37	34.09	41.49	34.21	56.00	46.00	-14.51	-11.79

Remarks:

1. Q.P. and AV. are abbreviations of quasi-peak and average individually.
2. The emission levels of other frequencies were very low against the limit.
3. Margin value = Emission level – Limit value
4. Correction factor = Insertion loss + Cable loss
5. Emission Level = Correction Factor + Reading Value

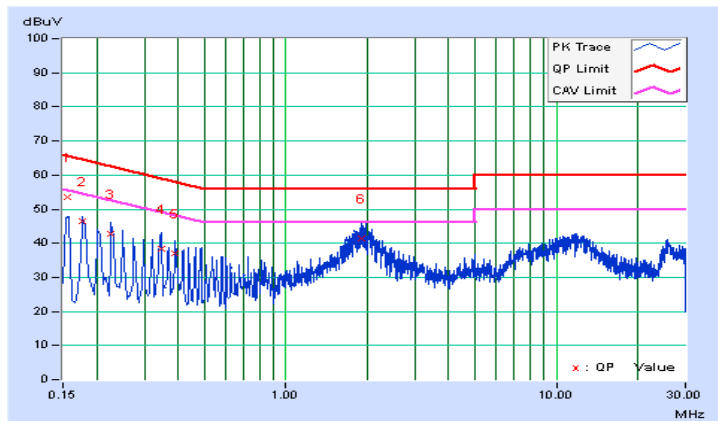



A D T

<b>PHASE</b>	Line 2	<b>6dB BANDWIDTH</b>	9kHz
--------------	--------	----------------------	------

Phase Of Power : Neutral (N)										
No	Frequency (MHz)	Correction Factor (dB)	Reading Value (dBuV)		Emission Level (dBuV)		Limit (dBuV)		Margin (dB)	
			Q.P.	AV.	Q.P.	AV.	Q.P.	AV.	Q.P.	AV.
1	0.15000	0.05	51.33	29.39	51.38	29.44	66.00	56.00	-14.62	-26.56
2	0.18568	0.05	43.14	31.72	43.19	31.77	64.23	54.23	-21.04	-22.46
3	0.31400	0.06	48.02	24.63	48.08	24.69	59.86	49.86	-11.79	-25.18
4	0.42200	0.06	37.92	25.51	37.98	25.57	57.41	47.41	-19.43	-21.84
5	1.23400	0.09	38.78	30.62	38.87	30.71	56.00	46.00	-17.13	-15.29
<b>6</b>	<b>1.84709</b>	<b>0.11</b>	<b>43.44</b>	<b>38.29</b>	<b>43.55</b>	<b>38.40</b>	<b>56.00</b>	<b>46.00</b>	<b>-12.45</b>	<b>-7.60</b>

Remarks:

1. Q.P. and AV. are abbreviations of quasi-peak and average individually.
2. The emission levels of other frequencies were very low against the limit.
3. Margin value = Emission level – Limit value
4. Correction factor = Insertion loss + Cable loss
5. Emission Level = Correction Factor + Reading Value

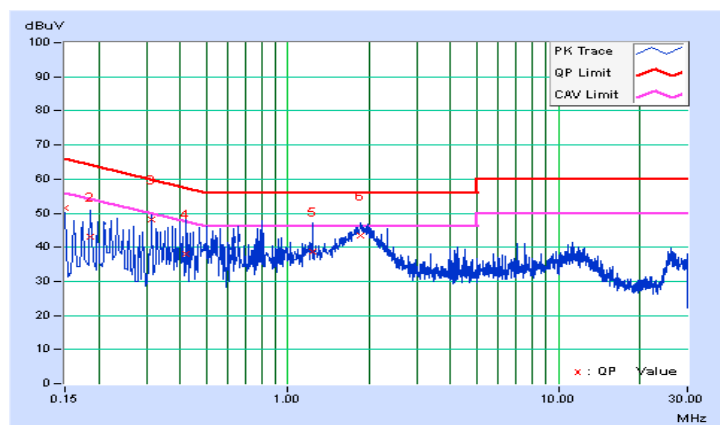



A D T

**MODE C**

<b>PHASE</b>	Line 1	<b>6dB BANDWIDTH</b>	9kHz
--------------	--------	----------------------	------

Phase Of Power : Neutral (N)										
No	Frequency (MHz)	Correction Factor (dB)	Reading Value (dBuV)		Emission Level (dBuV)		Limit (dBuV)		Margin (dB)	
			Q.P.	AV.	Q.P.	AV.	Q.P.	AV.	Q.P.	AV.
1	0.16600	0.05	40.48	22.41	40.53	22.46	65.16	55.16	-24.62	-32.69
2	0.21400	0.06	37.80	24.94	37.86	25.00	63.05	53.05	-25.19	-28.05
3	0.30600	0.06	36.99	16.93	37.05	16.99	60.08	50.08	-23.03	-33.09
4	0.40600	0.06	33.99	15.61	34.05	15.67	57.73	47.73	-23.68	-32.06
5	0.54200	0.06	30.40	14.02	30.46	14.08	56.00	46.00	-25.54	-31.92
6	1.92200	0.12	36.65	29.31	36.77	29.43	56.00	46.00	-19.23	-16.57

Remarks:

1. Q.P. and AV. are abbreviations of quasi-peak and average individually.
2. The emission levels of other frequencies were very low against the limit.
3. Margin value = Emission level – Limit value
4. Correction factor = Insertion loss + Cable loss
5. Emission Level = Correction Factor + Reading Value

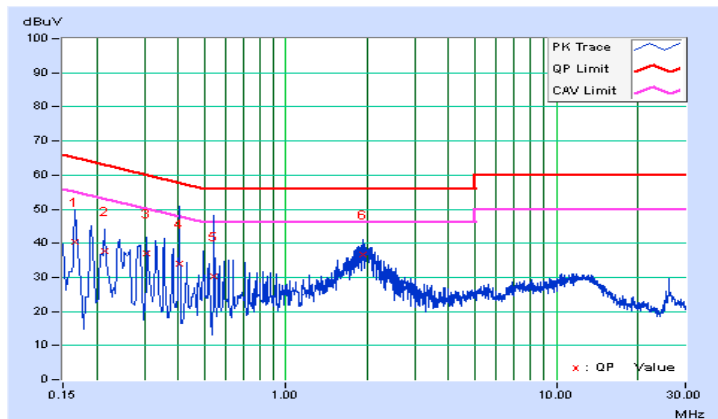



A D T

<b>PHASE</b>	Line 2	<b>6dB BANDWIDTH</b>	9kHz
--------------	--------	----------------------	------

Phase Of Power : Neutral (N)										
No	Frequency (MHz)	Correction Factor (dB)	Reading Value (dBuV)		Emission Level (dBuV)		Limit (dBuV)		Margin (dB)	
			Q.P.	AV.	Q.P.	AV.	Q.P.	AV.	Q.P.	AV.
1	0.15400	0.05	47.89	27.94	47.94	27.99	65.78	55.78	-17.84	-27.79
2	0.25000	0.05	49.13	32.57	49.18	32.62	61.76	51.76	-12.57	-19.13
3	0.34600	0.06	45.77	24.34	45.83	24.40	59.06	49.06	-13.23	-24.66
4	0.39000	0.06	42.58	23.13	42.64	23.19	58.06	48.06	-15.42	-24.87
5	0.57796	0.07	40.99	22.49	41.06	22.56	56.00	46.00	-14.94	-23.44
6	1.90140	0.11	38.99	33.71	39.10	33.82	56.00	46.00	-16.90	-12.18

Remarks:

1. Q.P. and AV. are abbreviations of quasi-peak and average individually.
2. The emission levels of other frequencies were very low against the limit.
3. Margin value = Emission level – Limit value
4. Correction factor = Insertion loss + Cable loss
5. Emission Level = Correction Factor + Reading Value

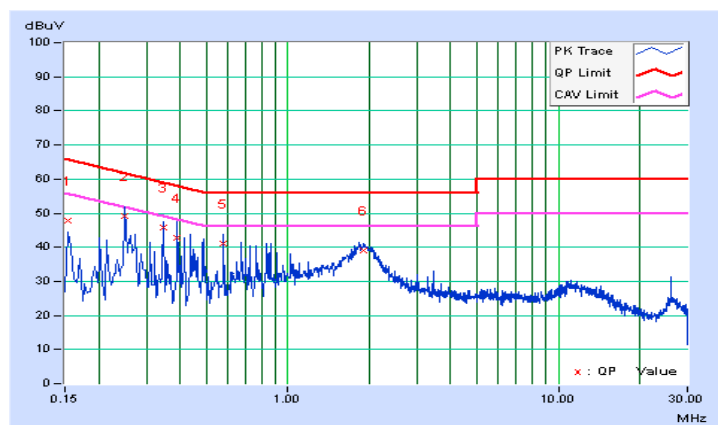

## 4.3 6dB BANDWIDTH MEASUREMENT

### 4.3.1 LIMITS OF 6dB BANDWIDTH MEASUREMENT

The minimum of 6dB Bandwidth Measurement is 0.5 MHz.

### 4.3.2 TEST SETUP

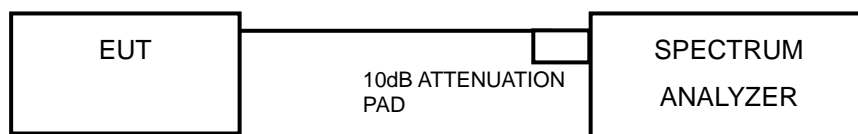

### 4.3.3 TEST INSTRUMENTS

Refer to section 4.1.2 to get information of above instrument.

### 4.3.4 TEST PROCEDURE

- Set resolution bandwidth (RBW) = 100kHz
- Set the video bandwidth (VBW)  $\geq 3 \times$  RBW, Detector = Peak.
- Trace mode = max hold.
- Sweep = auto couple.
- Measure the maximum width of the emission that is constrained by the frequencies associated with the two amplitude points (upper and lower) that are attenuated by 6 dB relative to the maximum level measured in the fundamental emission

### 4.3.5 DEVIATION FROM TEST STANDARD

No deviation.

### 4.3.6 EUT OPERATING CONDITIONS

The software provided by client to enable the EUT under transmission condition continuously at lowest, middle and highest channel frequencies individually.



A D T

#### 4.3.7 TEST RESULTS

##### 802.11b

CHANNEL	FREQUENCY (MHz)	6dB BANDWIDTH (MHz)	MINIMUM LIMIT (MHz)	PASS / FAIL
1	2412	10.07	0.5	PASS
6	2437	10.12	0.5	PASS
11	2462	10.10	0.5	PASS

##### 802.11g

CHANNEL	FREQUENCY (MHz)	6dB BANDWIDTH (MHz)	MINIMUM LIMIT (MHz)	PASS / FAIL
1	2412	16.41	0.5	PASS
6	2437	16.39	0.5	PASS
11	2462	16.41	0.5	PASS

##### 802.11n (20MHz)

CHANNEL	FREQUENCY (MHz)	6dB BANDWIDTH (MHz)	MINIMUM LIMIT (MHz)	PASS / FAIL
1	2412	17.66	0.5	PASS
6	2437	17.63	0.5	PASS
11	2462	17.63	0.5	PASS

##### 802.11n (40MHz)

CHANNEL	FREQUENCY (MHz)	6dB BANDWIDTH (MHz)	MINIMUM LIMIT (MHz)	PASS / FAIL
3	2422	36.09	0.5	PASS
6	2437	36.13	0.5	PASS
9	2452	36.13	0.5	PASS



A D T

### SPECTRUM PLOT OF WORST VALUE

#### 802.11b

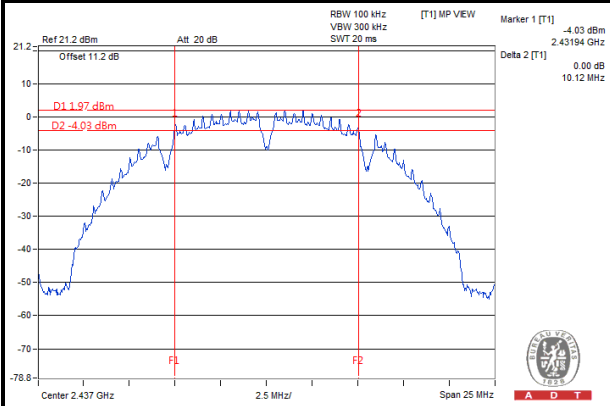

#### 802.11g

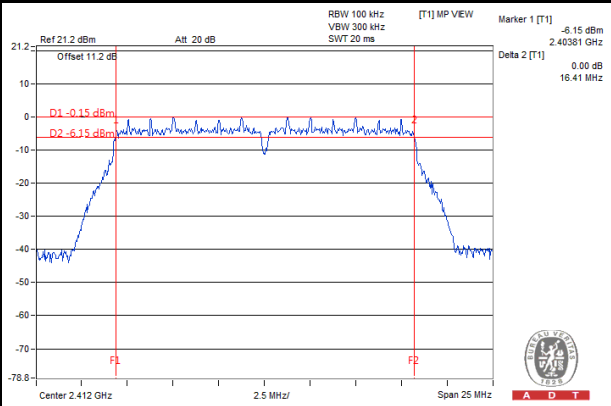

#### 802.11n (20MHz)

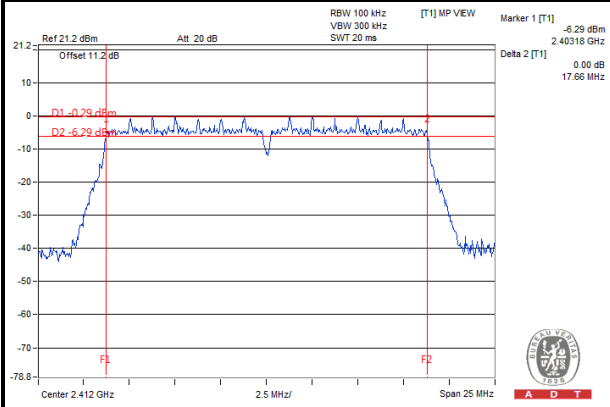

#### 802.11n (40MHz)

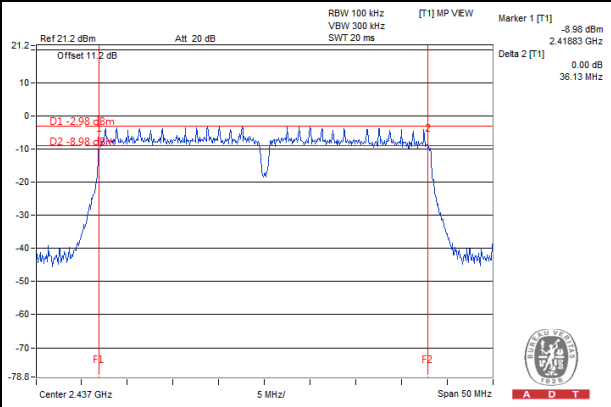

## 4.4 CONDUCTED OUTPUT POWER

### 4.4.1 LIMITS OF CONDUCTED OUTPUT POWER MEASUREMENT

For systems using digital modulation in the 2400–2483.5 MHz bands: 1 Watt (30dBm)

### 4.4.2 TEST SETUP

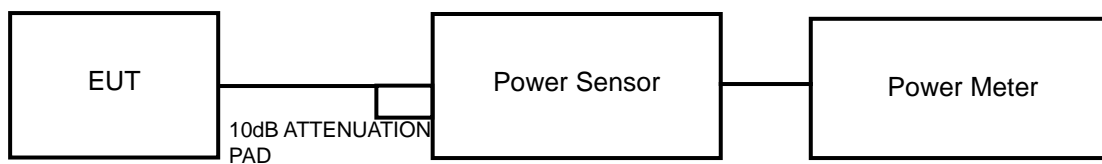

### 4.4.3 TEST INSTRUMENTS

Refer to section 4.1.2 to get information of above instrument.

### 4.4.4 TEST PROCEDURES

A peak power sensor was used on the output port of the EUT. A power meter was used to read the response of the peak power sensor. Record the peak power level.

### 4.4.5 DEVIATION FROM TEST STANDARD

No deviation.

### 4.4.6 EUT OPERATING CONDITIONS

Same as section 4.3.6.





A D T

#### 4.4.7 TEST RESULTS

##### 802.11b

CHANNEL	FREQUENCY (MHz)	PEAK POWER (mW)	PEAK POWER (dBm)	LIMIT (dBm)	PASS / FAIL
1	2412	19.72	12.95	30	PASS
6	2437	20.51	13.12	30	PASS
11	2462	19.86	12.98	30	PASS

##### 802.11g

CHANNEL	FREQUENCY (MHz)	PEAK POWER (mW)	PEAK POWER (dBm)	LIMIT (dBm)	PASS / FAIL
1	2412	143.88	21.58	30	PASS
6	2437	150.66	21.78	30	PASS
11	2462	144.54	21.6	30	PASS

##### 802.11n (20MHz)

CHANNEL	FREQUENCY (MHz)	PEAK POWER (mW)	PEAK POWER (dBm)	LIMIT (dBm)	PASS / FAIL
1	2412	156.31	21.94	30	PASS
6	2437	166.34	22.21	30	PASS
11	2462	162.55	22.11	30	PASS

##### 802.11n (40MHz)

CHANNEL	FREQUENCY (MHz)	PEAK POWER (mW)	PEAK POWER (dBm)	LIMIT (dBm)	PASS / FAIL
3	2422	171.79	22.35	30	PASS
6	2437	178.24	22.51	30	PASS
9	2452	171.40	22.34	30	PASS

## 4.5 POWER SPECTRAL DENSITY MEASUREMENT

### 4.5.1 LIMITS OF POWER SPECTRAL DENSITY MEASUREMENT

The Maximum of Power Spectral Density Measurement is 8dBm.

### 4.5.2 TEST SETUP

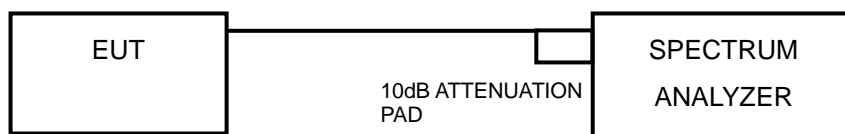

### 4.5.3 TEST INSTRUMENTS

Refer to section 4.1.2 to get information of above instrument.

### 4.5.4 TEST PROCEDURE

- Set the RBW = 3 kHz, VBW =10 kHz, Detector = peak.
- Sweep time = auto couple, Trace mode = max hold, allow trace to fully stabilize.
- Use the peak marker function to determine the maximum power level in any 100 kHz band segment within the fundamental EBW.

### 4.5.5 DEVIATION FROM TEST STANDARD

No deviation.

### 4.5.6 EUT OPERATING CONDITION

Same as section 4.3.6.



A D T

#### 4.5.7 TEST RESULTS

##### 802.11b

CHANNEL	FREQUENCY (MHz)	PSD (dBm/3kHz)	LIMIT (dBm/3kHz)	PASS / FAIL
1	2412	-11.80	8	PASS
6	2437	-12.25	8	PASS
11	2462	-11.83	8	PASS

##### 802.11g

CHANNEL	FREQUENCY (MHz)	PSD (dBm/3kHz)	LIMIT (dBm/3kHz)	PASS / FAIL
1	2412	-14.41	8	PASS
6	2437	-14.67	8	PASS
11	2462	-14.91	8	PASS

##### 802.11n (20MHz)

CHANNEL	FREQUENCY (MHz)	PSD (dBm/3kHz)	LIMIT (dBm/3kHz)	PASS / FAIL
1	2412	-14.75	8	PASS
6	2437	-14.67	8	PASS
11	2462	-14.94	8	PASS

##### 802.11n (40MHz)

CHANNEL	FREQUENCY (MHz)	PSD (dBm/3kHz)	LIMIT (dBm/3kHz)	PASS / FAIL
3	2422	-17.55	8	PASS
6	2437	-17.50	8	PASS
9	2452	-17.36	8	PASS



A D T

### SPECTRUM PLOT OF WORST VALUE

#### 802.11b

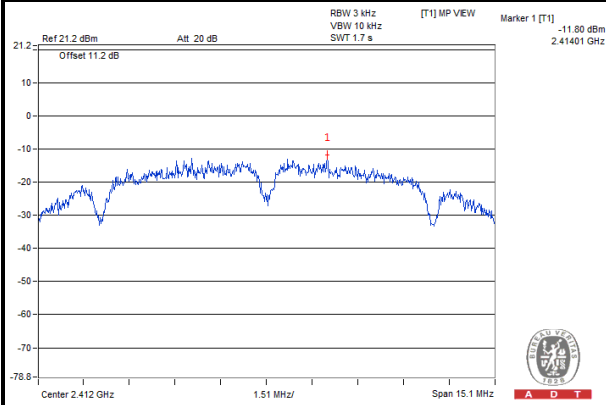

#### 802.11g

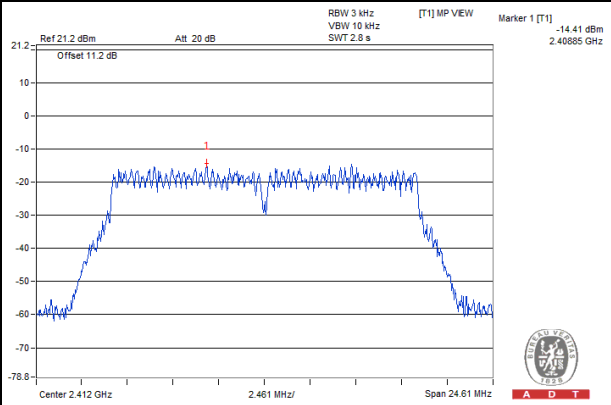

#### 802.11n (20MHz)

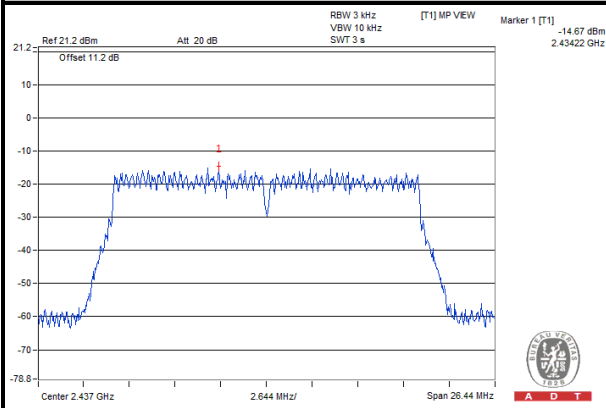

#### 802.11n (40MHz)

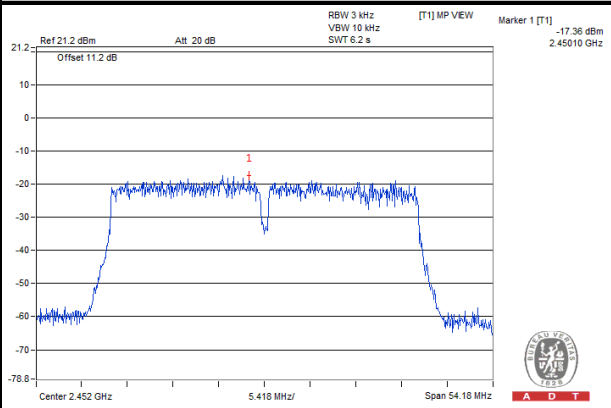

## 4.6 CONDUCTED OUT OF BAND EMISSION MEASUREMENT

### 4.6.1 LIMITS OF CONDUCTED OUT OF BAND EMISSION MEASUREMENT

Below  $-20\text{dB}$  of the highest emission level of operating band (in 100kHz Resolution Bandwidth).

### 4.6.2 TEST SETUP

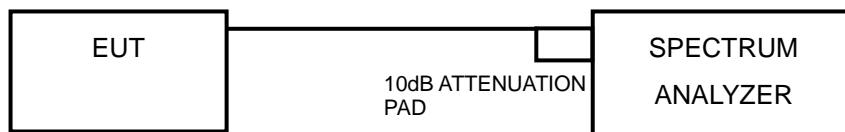

### 4.6.3 TEST INSTRUMENTS

Refer to section 4.1.2 to get information of above instrument.

### 4.6.4 TEST PROCEDURE

#### MEASUREMENT PROCEDURE REF

1. Set the RBW = 100 kHz.
2. Set the VBW  $\geq$  300 kHz.
3. Detector = peak.
4. Sweep time = auto couple.
5. Trace mode = max hold.
6. Allow trace to fully stabilize.
7. Use the peak marker function to determine the maximum power level in any 100 kHz band segment within the fundamental EBW.

#### MEASUREMENT PROCEDURE OOB

1. Set RBW = 100 kHz.
2. Set VBW  $\geq$  300 kHz.
3. Detector = peak.
4. Sweep = auto couple.
5. Trace Mode = max hold.
6. Allow trace to fully stabilize.
7. Use the peak marker function to determine the maximum amplitude level.

### 4.6.5 DEVIATION FROM TEST STANDARD

No deviation.

### 4.6.6 EUT OPERATING CONDITION

Same as section 4.3.6.



A D T

### 4.6.7 TEST RESULTS

The spectrum plots are attached on the following images. D1 line indicates the highest level, and D2 line indicates the 20dB offset below D1. It shows compliance with the requirement.

#### 802.11b

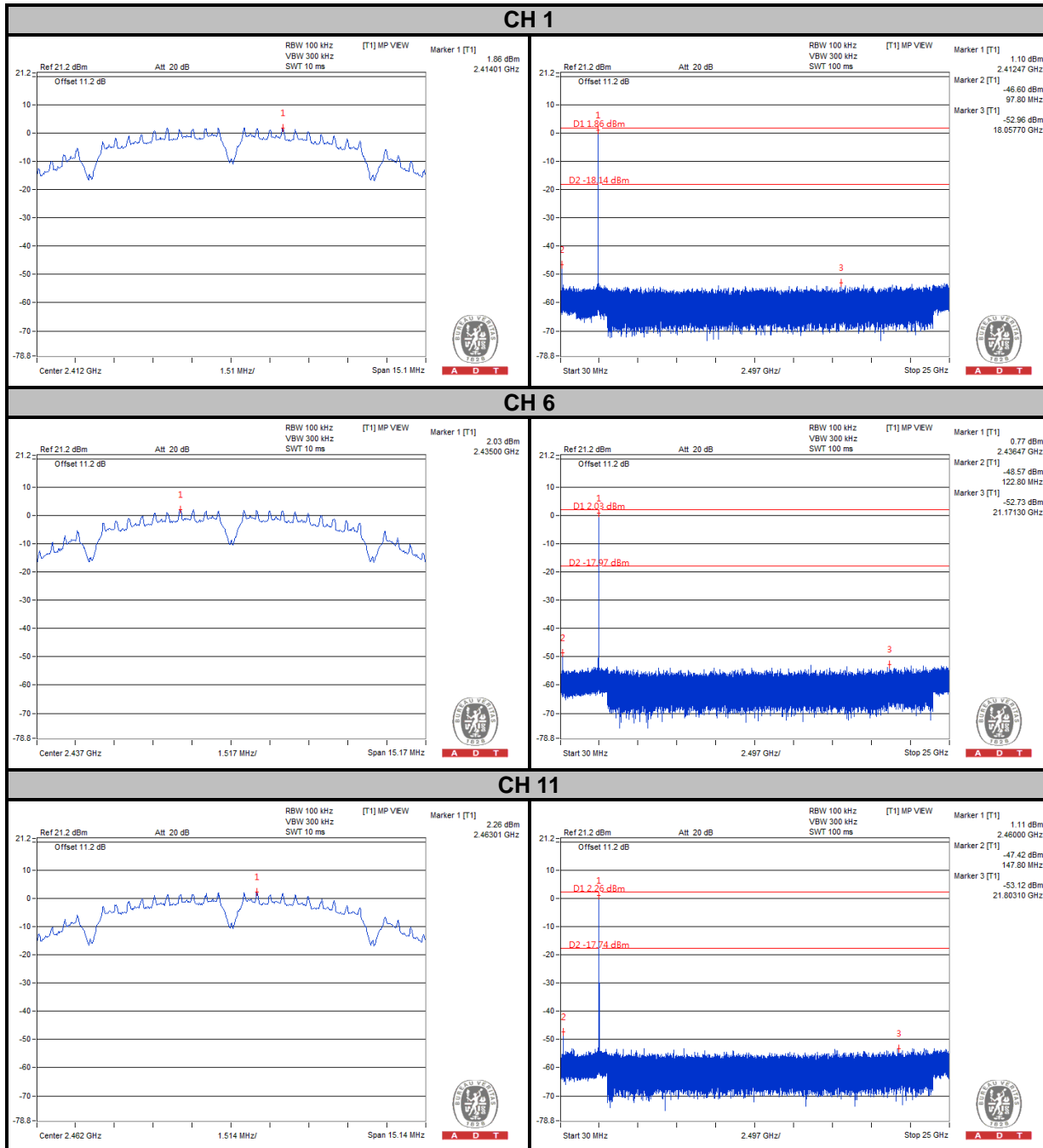



A D T

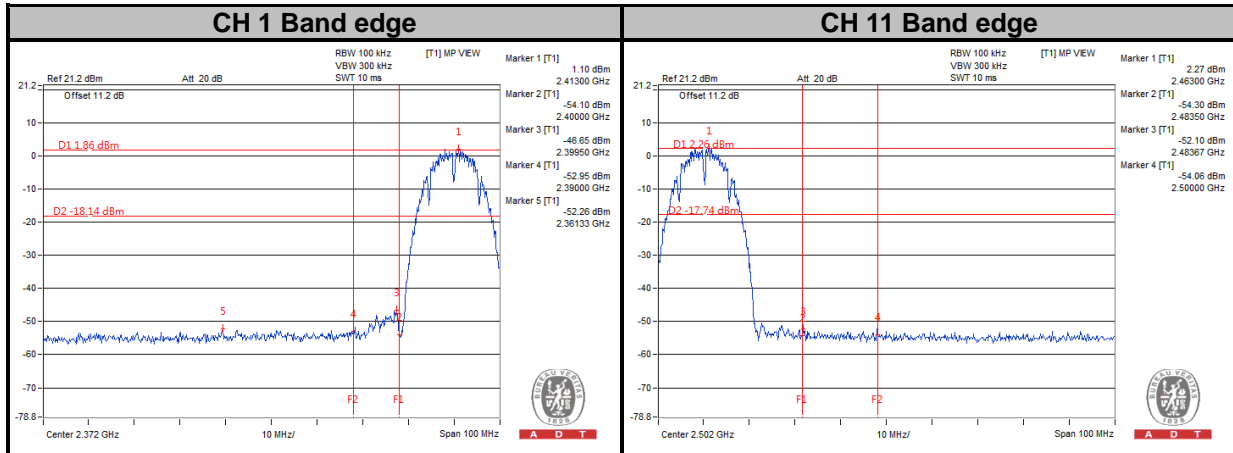



A D T

### 802.11g

#### CH 1

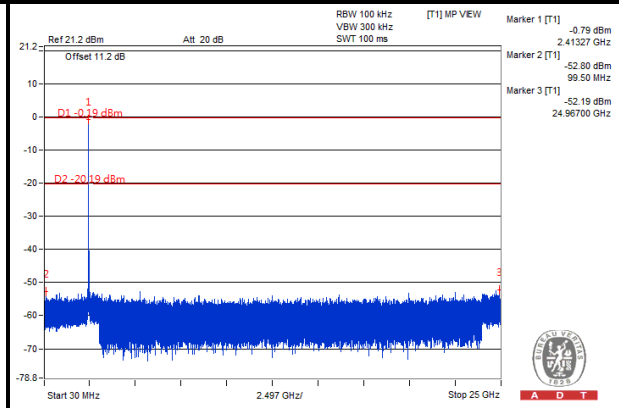
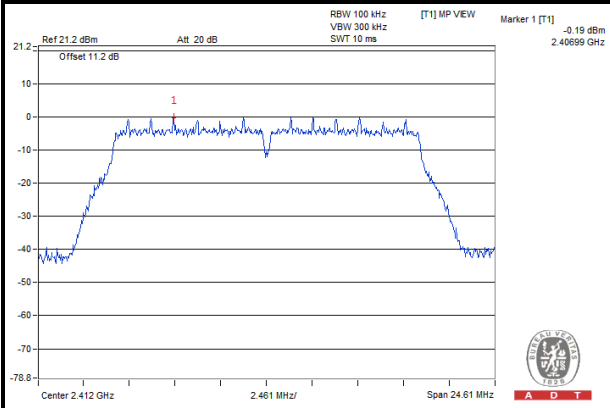

#### CH 6

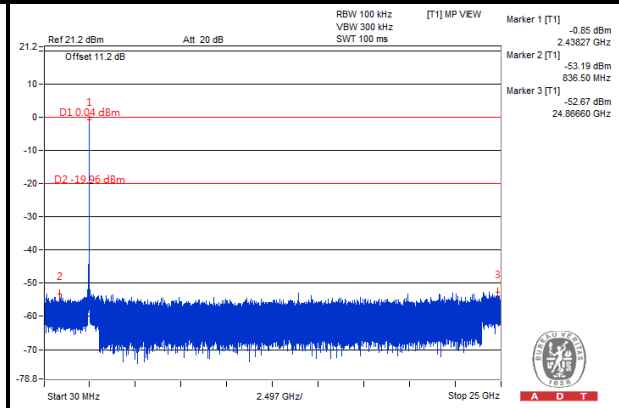
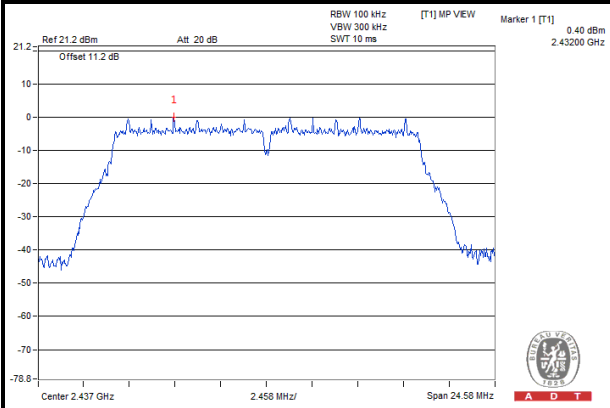

#### CH 11

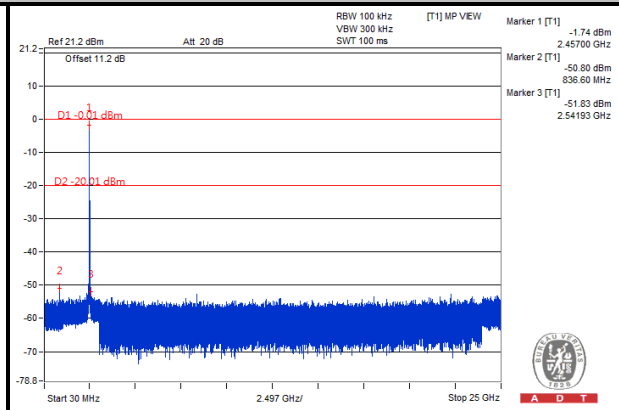
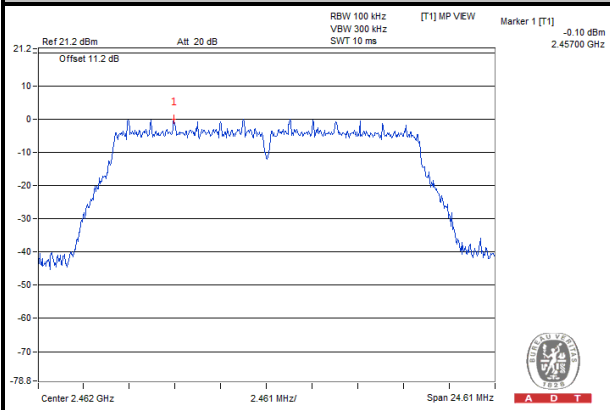





A D T

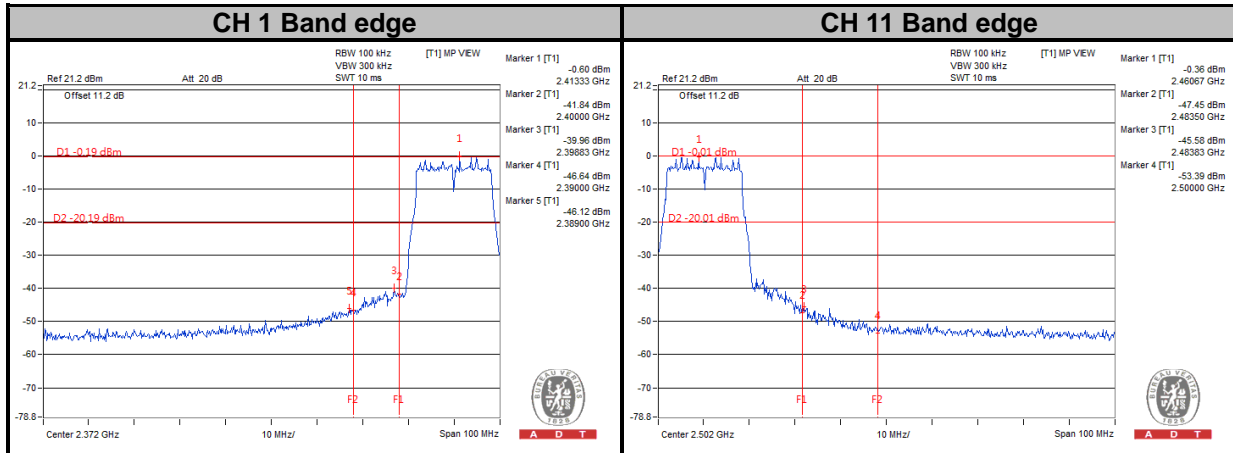



A D T

# 802.11n (20MHz)

## CH 1

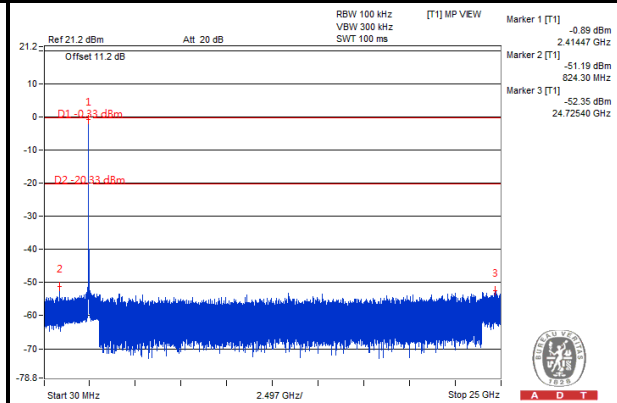
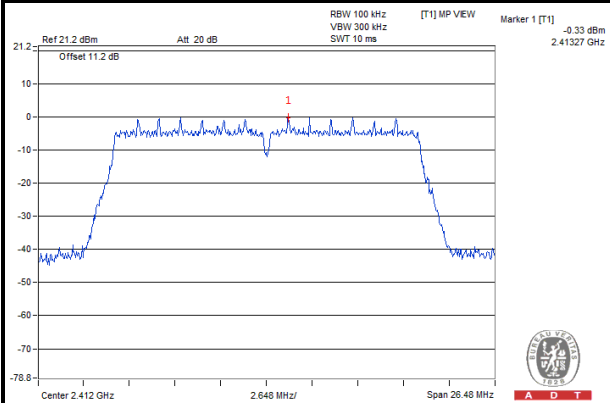

## CH 6

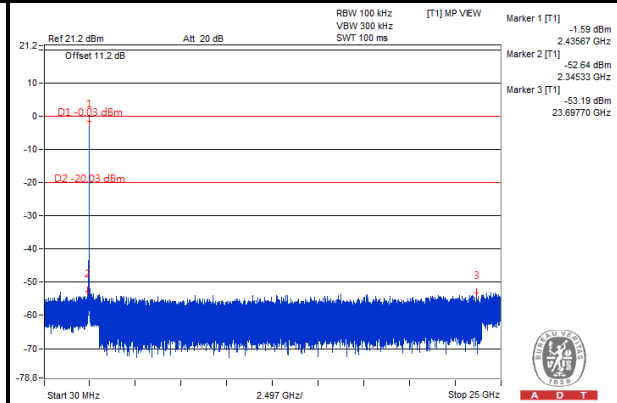
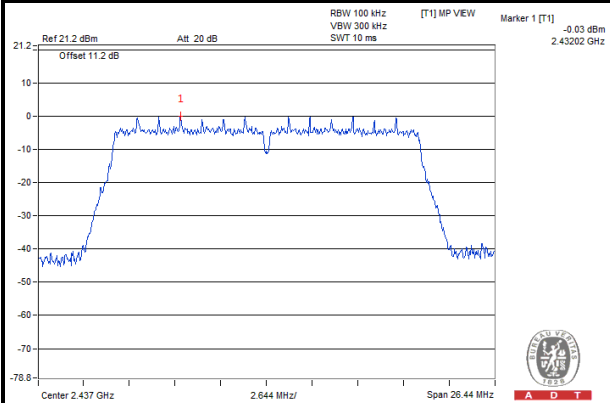

## CH 11

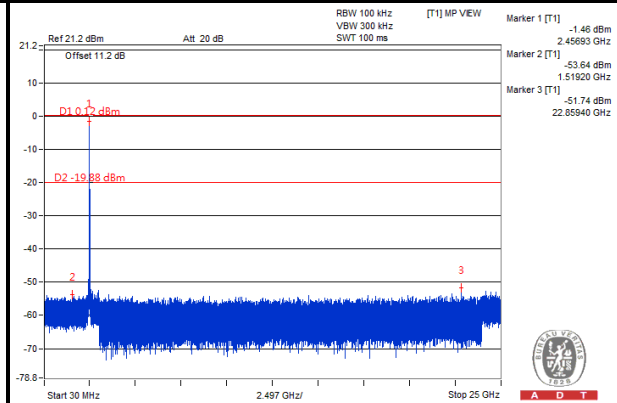
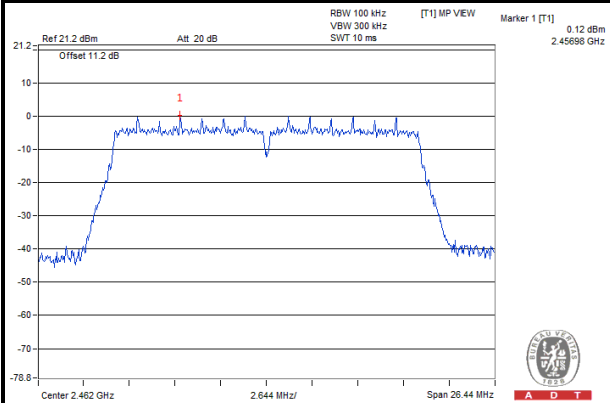



A D T

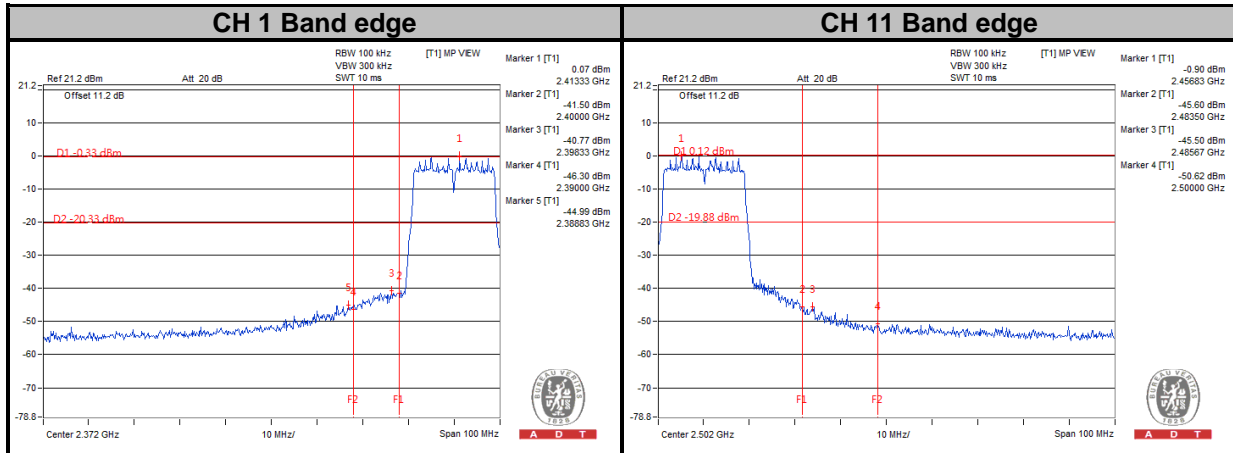



A D T

### 802.11n (40MHz)

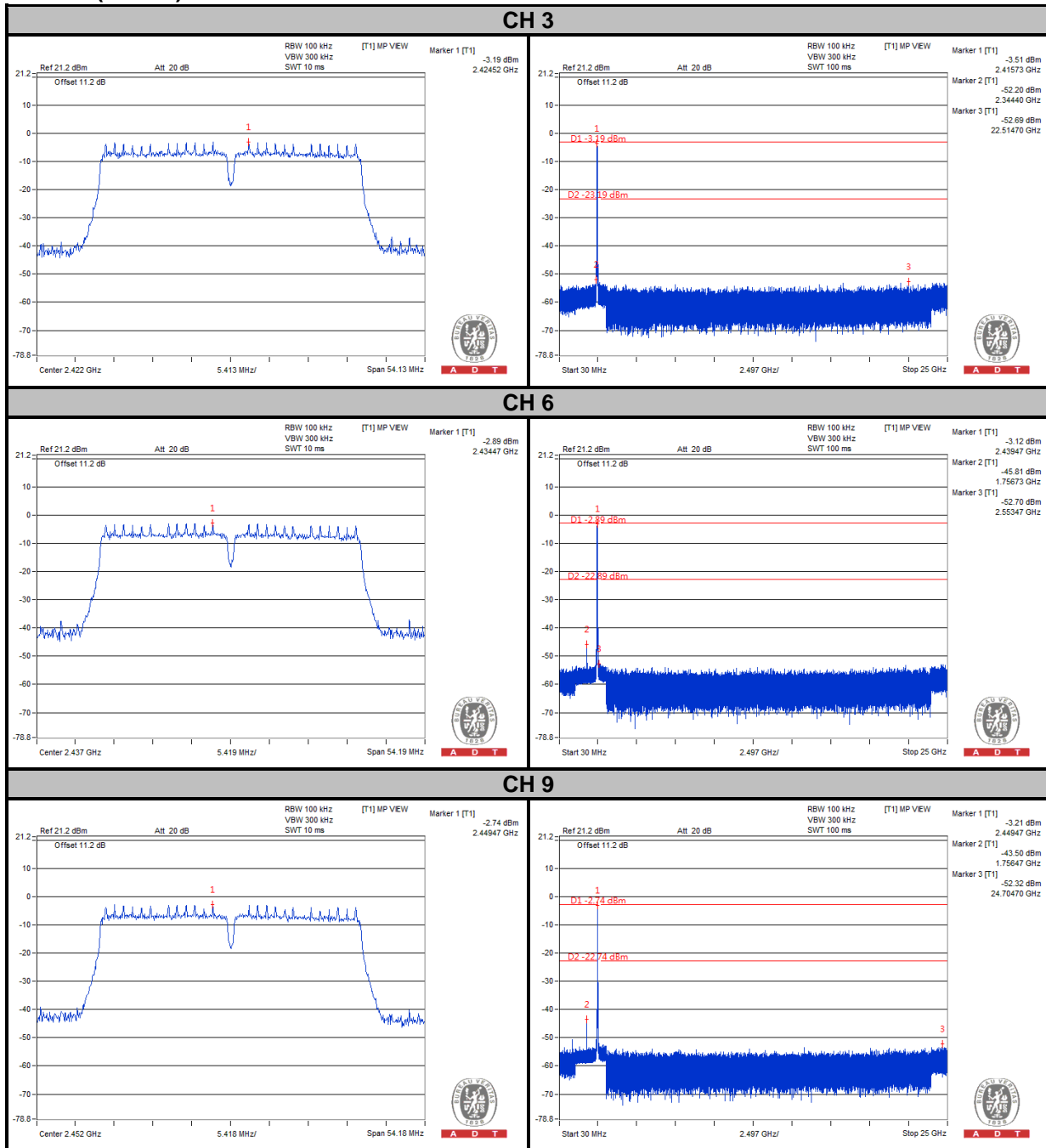



A D T

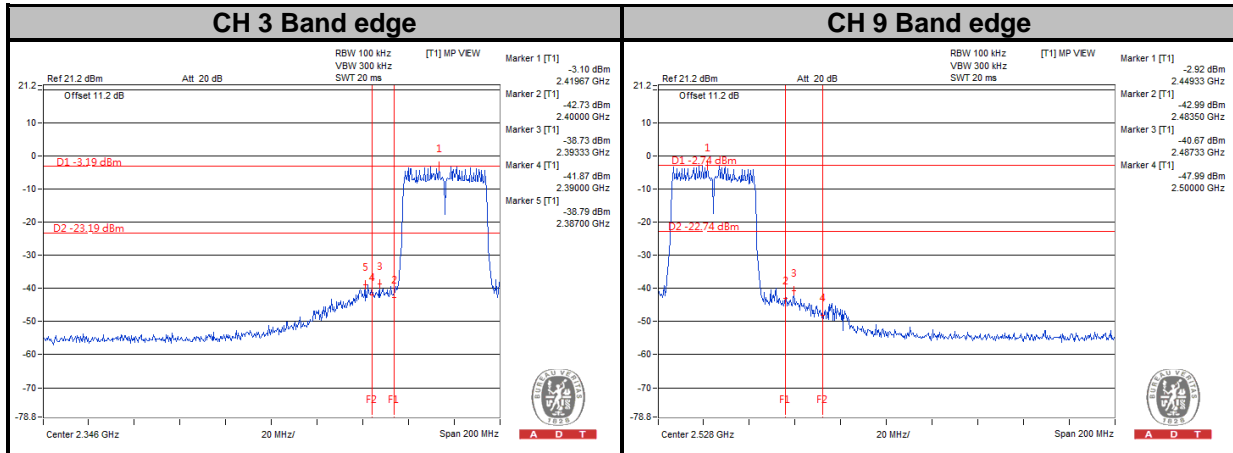



A D T

## 5. PHOTOGRAPHS OF THE TEST CONFIGURATION

Please refer to the attached file (Test Setup Photo).



## 6. INFORMATION ON THE TESTING LABORATORIES

We, Bureau Veritas Consumer Products Services (H.K.) Ltd., Taoyuan Branch, were founded in 1988 to provide our best service in EMC, Radio, Telecom and Safety consultation. Our laboratories are accredited and approved according to ISO/IEC 17025.

If you have any comments, please feel free to contact us at the following:

**Linko EMC/RF Lab:**

Tel: 886-2-26052180

Fax: 886-2-26051924

**Hsin Chu EMC/RF/Telecom Lab:**

Tel: 886-3-5935343

Fax: 886-3-5935342

**Hwa Ya EMC/RF/Safety Lab:**

Tel: 886-3-3183232

Fax: 886-3-3270892

**Email:** [service.adt@tw.bureauveritas.com](mailto:service.adt@tw.bureauveritas.com)

**Web Site:** [www.bureauveritas-adt.com](http://www.bureauveritas-adt.com)

The address and road map of all our labs can be found in our web site also.



A D T

## **7. APPENDIX A – MODIFICATIONS RECORDERS FOR ENGINEERING CHANGES TO THE EUT BY THE LAB**

No any modifications are made to the EUT by the lab during the test.

---END---