



Report No.: SER180628704006E

# FCC CFR47 PART 22H, 24E, 27 CERTIFICATION TEST REPORT

## FCC ID: 2ACC5-GT50VH2

**Product:** Handheld Device  
**Trade Mark:** N/A  
**Model Number:** GT50VH2  
**Serial Model:** N/A  
**Report No.:** SER180628704006E

### Prepared for

AMobile Intelligent Corp.  
8F.-1, No.700, Zhongzheng Rd., Zhonghe Dist New Taipei City,  
235 Taiwan

### Prepared by

Shenzhen NTEK Testing Technology Co., Ltd.  
1/F, Building E, Fenda Science Park, Sanwei Community, Xixiang Street  
Bao'an District, Shenzhen 518126 P.R. China  
Tel.: +86-755-6115 9388 Fax.: +86-755-6115 6599  
Website:<http://www.ntek.org.cn>



### TEST RESULT CERTIFICATION

**Applicant's name** ..... : AMobile Intelligent Corp.  
**Address** ..... : 8F.-1, No.700, Zhongzheng Rd., Zhonghe Dist New Taipei City, 235  
 Taiwan  
**Manufacturer's Name** ..... : AMobile Intelligent Corp.  
**Address** ..... : 8F.-1, No.700, Zhongzheng Rd., Zhonghe Dist New Taipei City, 235  
 Taiwan  
**Product name**..... : Handheld Device  
**Model and/or type reference** ... : GT50VH2  
**Serial Model:** N/A  
**Standards**..... : FCC CFR 47 Part 22H, Part 24E, Part 27  
**Test procedure** ..... : ANSI C63.26:2015  
 ANSI/TIA-603-E-2016

This device described above has been tested by NTEK, and the test results show that the equipment under test (EUT) is in compliance with the FCC requirements. And it is applicable only to the tested sample identified in the report.

This report shall not be reproduced except in full, without the written approval of NTEK, this document may be altered or revised by NTEK, personal only, and shall be noted in the revision of the document.

**Date of Test** .....

Date (s) of performance of tests ..... 28 Jun. 2018 ~ 24 Aug. 2018

Date of Issue ..... 24 Aug. 2018

Test Result ..... **Pass**

Testing Engineer : Loren Luo

(Loren Luo)

Technical Manager : Jason chen

(Jason Chen)

Authorized Signatory : Sam. Chen

(Sam Chen)



## TABLE OF CONTENTS

**1. GENERAL INFORMATION .....6**

**1. GENERAL INFORMATION .....6**

**1.1 PRODUCT DESCRIPTION ..... 6**

**1.2 RELATED SUBMITTAL(S) / GRANT (S)..... 7**

**1.3 TEST METHODOLOGY ..... 7**

**1.4 TEST FACILITY ..... 7**

**MEASUREMENT UNCERTAINTY ..... 7**

**1.5 SPECIAL ACCESSORIES..... 7**

**1.6 WORST-CASE CONFIGURATION AND MODE..... 7**

**2. SYSTEM TEST CONFIGURATION .....8**

**2.1 EUT CONFIGURATION ..... 8**

**2.2 EUT EXERCISE ..... 8**

**2.3 CONFIGURATION OF EUT SYSTEM..... 8**

**2.4 TEST SETUP ..... 9**

**3.TEST AND MEASUREMENT EQUIPMENT ..... 10**

**4. OUTPUT POWER..... 11**

**4.1 OUTPUT POWER MEASUREMENT .....11**

**4.2 LTE BAND 2 ..... 13**

**4.3 LTE BAND 4 ..... 19**

**4.4 LTE BAND 13 ..... 25**

**5. OCCUPIED BANDWIDTH.....27**

**5.1 LTE BAND 2 ..... 30**

**5.2 LTE BAND 4 ..... 36**

**5.4 LTE BAND 13 ..... 42**



**6. BANDEDGE AND EMISSION MASK .....42**

6.1 LTE BAND 2 ..... 45

6.2 LTE BAND 4 ..... 69

6.3 LTE BAND 13 ..... 93

**7. OUT OF BAND EMISSIONS.....101**

7.1 MEASUREMENT METHOD ..... 101

7.1 LTE BAND 2 ..... 102

7.2 LTE BAND 4 ..... 126

7.3 LTE BAND 13 ..... 150

**8. RADIATED SPURIOUS EMISSION.....158**

8.1. RADIATED POWER (ERP & EIRP)..... 158

8.2 LTE BAND 2 ..... 159

8.3 LTE BAND 4 ..... 163

8.4 LTE BAND 13 ..... 167

**9. FIELD STRENGTH OF SPURIOUS RADIATION.....169**

9.1 LTE BAND 2 ..... 171

9.2 LTE BAND 4 ..... 172

9.3 LTE BAND 13 ..... 173

**10. FREQUENCY STABILITY .....174**

10.1 LTE BAND 2 ..... 175

10.2 LTE BAND 4 ..... 177

10.3 LTE BAND 13 ..... 179

**11. PEAK-TO-AVERAGE RATIO .....181**

11.1 Description of the PAR Measurement ..... 181

11.2 Measuring Instruments ..... 181

11.3 Test Procedures ..... 181

11.4 Test Setup ..... 181

11.5 LTE BAND 2 ..... 184



Report No.: SER180628704006E

11.6 LTE BAND 4..... 184

11.7 LTE BAND 13 ..... 196



## 1. GENERAL INFORMATION

### 1.1 PRODUCT DESCRIPTION

A major technical description of EUT is described as following:

Product Designation:	Handheld Device
Trade Mark	N/A
Model Name	GT50VH2
FCC ID:	2ACC5-GT50VH2
Frequency Bands:	U.S. Bands: <input checked="" type="checkbox"/> LTE FDD Band 2,4,13
Frequency Range:	LTE FDD Band 2 Uplink: 1850MHz-1910MHz, Downlink: 1930MHz-1990MHz; LTE FDD Band 4 Uplink: 1710MHz-1755MHz, Downlink: 2110MHz-2155MHz; LTE FDD Band 13 Uplink: 777MHz-787MHz, Downlink: 746MHz-756MHz;
Type of Modulation:	QPSK/16QAM
Antenna:	FPCB Antenna
Antenna gain:	B2:-0.73dBi; B4: -0.69dBi; B13: -0.52dBi
Power Supply:	DC 3.8V from Battery or DC 5V from USB port
Battery parameter:	DC 3.8V, 5200mAh
Adapter:	Model:PSAF10R-050Q Input: 100-240V~50-60Hz 0.3A Output: 5V---2.0A
Extreme Vol. Limits:	DC 3.45V to 4.45V (Nominal DC 3.8V)
Extreme Temp. Tolerance	-30°C to +50°C
HW Version	GT-500V_MB_V1.1_170929
SW Version	V018.08.01
** Note: The High Voltage 4.37V and Low Voltage 3.23V was declared by manufacturer, The EUT couldn't be operate normally with higher or lower voltage.	



### 1.2 RELATED SUBMITTAL(S) / GRANT (S)

This submittal(s) (test report) is intended for **FCC ID: 2ACC5-GT50VH2** filing to comply with the FCC Part 22H&24E &27.

### 1.3 TEST METHODOLOGY

The tests documented in this report were performed in accordance with ANSI/TIA-603-E-2016, FCC CFR 47 Part 2, Part 22, Part 24, Part 27, ANSI C63.26:2015.

### 1.4 TEST FACILITY

The test site used to collect the radiated data is located at:

ShenZhen NTEK Testing Technology Co., Ltd.

1/F, Building E, Fenda Science Park, Sanwei Community, Xixiang Street, Bao'an District, Shenzhen 518126 P.R.China.

The test site is constructed and calibrated to meet the FCC requirements in documents ANSI C63.26:2015& ANSI C63.4: 2014.

FCC Registration No.:463705

IC Registration No.:9270A-1,

CNAS Registration No.:L5516

## MEASUREMENT UNCERTAINTY

The reported uncertainty of measurement, where expended uncertainty U is based on a standard uncertainty multiplied by a coverage factor of k=2, providing a level of confidence of approximately 95 %.

No.	Item	Uncertainty
1	Measuring Uncertainty for a Level of Confidence of 95% ( $U = 2Uc(y)$ )	2.5dB

### 1.5 SPECIAL ACCESSORIES

The battery and the charger, earphone supplied by the applicant were used as accessories and being tested with EUT intended for FCC grant together.

### 1.6 WORST-CASE CONFIGURATION AND MODE

The worst-case scenario for all measurements is based on the investigation results.

The device has LTE Bands of: Band 2, Band 4, Band 13

The RB Size was selected to measure for peak or average ERP and EIRP, which was based on the conducted power verification baseline data.

For the fundamental investigation of radiated emissions, the EUT is investigated for vertical and



horizontal antenna orientations and X Y and Z orientations of the EUT alone. After the investigations the worst case was determined to be at X orientation for all LTE bands.

## 2. SYSTEM TEST CONFIGURATION

### 2.1 EUT CONFIGURATION

The EUT configuration for testing is installed on RF field strength measurement to meet the Commission’s requirement and operating in a manner which intends to maximize its emission characteristics in a continuous normal application.

### 2.2 EUT EXERCISE

The Transmitter was operated in the maximum output power mode through Communication Tester. The TX frequency was fixed which was for the purpose of the measurements.

### 2.3 CONFIGURATION OF EUT SYSTEM

Table 2-1 Equipment Used in EUT System

Item	Equipment	Model No.	Series No.	Note
1	Handheld Device	GT50VH2	N/A	EUT

*Note: All the accessories have been used during the test. the following “EUT” in setup diagram means EUT system.*



## 2.4 TEST SETUP

### CONDUCTED SETUP DIAGRAM FOR TESTS

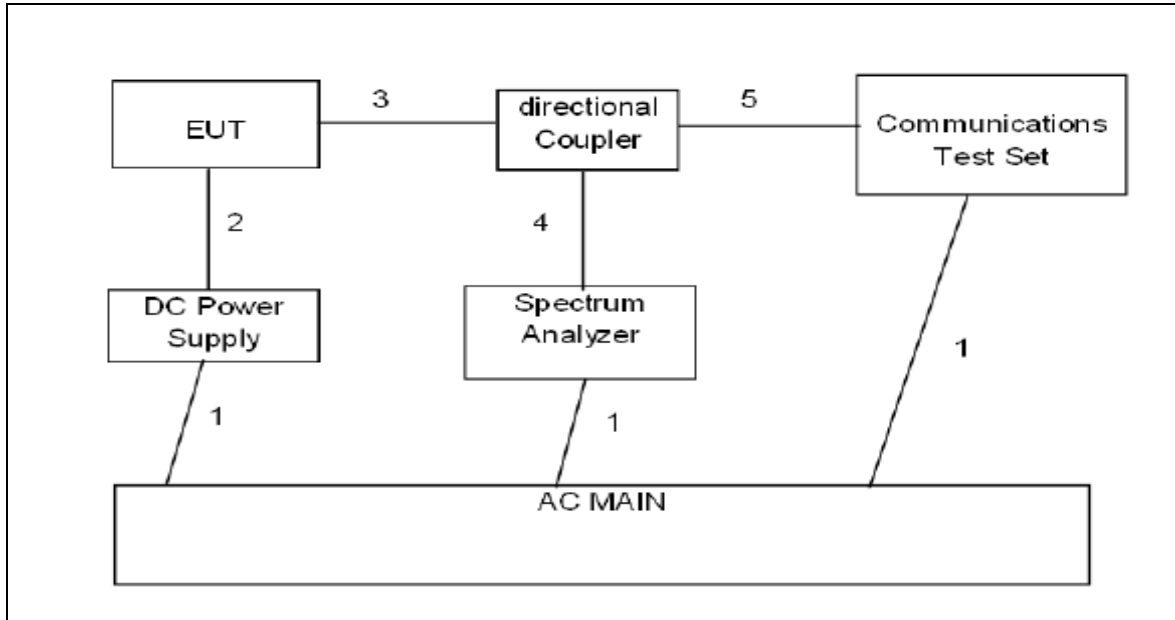

### RADIATED SETUP DIAGRAM FOR TESTS

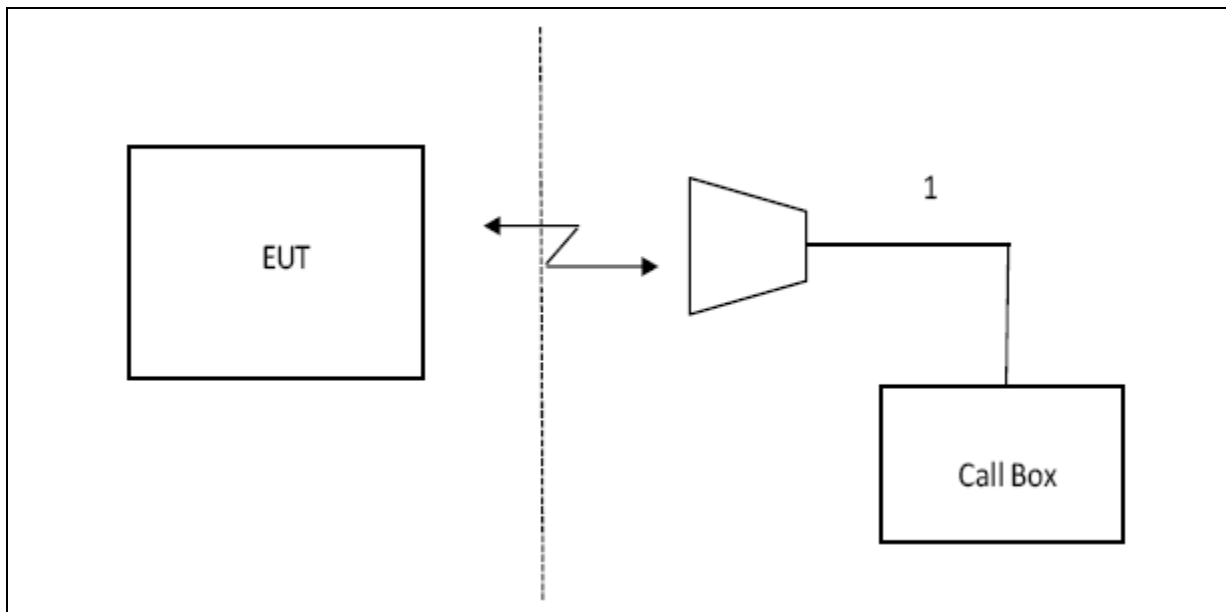



### 3. TEST AND MEASUREMENT EQUIPMENT

The following test and measurement equipment was utilized for the tests documented in this report:

NAME OF EQUIPMENT	MANUFACTURER	MODEL	SERIAL NUMBER	NEXT CAL. DATE
SPECTRUM ANALYZER	AGILENT	E4440A	US44300399	2019.03.28
TEST RECEIVER	R&S	ESCI	A0304218	2019.05.18
COMMUNICATION TESTER	R&S	CMU200	A0304247	2019.05.18
COMMUNICATION TESTER	R&S	CMW500	X	2019.05.18
TEST RECEIVER	R&S	FCKL1528	A0304230	2019.05.18
LISN	SCHWARZBECK	NSLK8127	A0304233	2019.05.18
CLIMATE CHAMBER	ALBATROSS	--	--	2019.05.18
Loop Antenna	Daze	ZN30900N	SEL0097	2019.05.18
Biological Antenna	A.H. Systems Inc.	SAS-521-4	N/A	2019.05.18
Horn Antenna	EM	EM-AH-10180	N/A	2019.04.07
DC Power Source	N/A	PS-6005D	20170402923	2020.06.05

## 4. OUTPUT POWER

### 4.1 OUTPUT POWER MEASUREMENT

#### LTE Measurement Procedure:

All LTE bands conducted power peak and average are obtained from the CMW500 telecommunication test set. The following tests were conducted according to the test requirements outlined in section 6.2 of the 3GPP TS36.101 specification.

UE Power Class: 3 (23 +/- 2dBm). The allowed Maximum Power Reduction (MPR) for the maximum output power due to higher order modulation and transmit bandwidth configuration (resource blocks) is specified in Table 6.2.3-1 of the 3GPP TS36.101.

**Table 6.2.3-1: Maximum Power Reduction (MPR) for Power Class 3**

Modulation	Channel bandwidth / Transmission bandwidth (RB)						MPR (dB)
	1.4 MHz	3.0 MHz	5 MHz	10 MHz	15 MHz	20 MHz	
QPSK	> 5	> 4	> 8	> 12	> 16	> 18	≤ 1
16 QAM	≤ 5	≤ 4	≤ 8	≤ 12	≤ 16	≤ 18	≤ 1
16 QAM	> 5	> 4	> 8	> 12	> 16	> 18	≤ 2

The allowed A-MPR values specified below in Table 6.2.4.-1 of 3GPP TS36.101 are in addition to the allowed MPR requirements. All the measurements below were performed with A-MPR disabled, by using Network Signaling Value of "NS\_01".3

**Table 6.2.4-1: Additional Maximum Power Reduction (A-MPR)**

Network Signalling value	Requirements (sub-clause)	E-UTRA Band	Channel bandwidth (MHz)	Resources Blocks ( $N_{RB}$ )	A-MPR (dB)
NS_01	6.6.2.1.1	Table 5.5-1	1.4, 3, 5, 10, 15, 20	Table 5.6-1	NA
NS_03	6.6.2.2.1	2, 4, 10, 23, 25, 35, 36	3	>5	$\leq 1$
			5	>6	$\leq 1$
			10	>6	$\leq 1$
			15	>8	$\leq 1$
			20	>10	$\leq 1$
NS_04	6.6.2.2.2	41	5	>6	$\leq 1$
			10, 15, 20	See Table 6.2.4-4	
NS_05	6.6.3.3.1	1	10, 15, 20	$\geq 50$	$\leq 1$
NS_06	6.6.2.2.3	12, 13, 14, 17	1.4, 3, 5, 10	Table 5.6-1	n/a
NS_07	6.6.2.2.3	13	10	Table 6.2.4-2	Table 6.2.4-2
	6.6.3.3.2				
NS_08	6.6.3.3.3	19	10, 15	> 44	$\leq 3$
NS_09	6.6.3.3.4	21	10, 15	> 40	$\leq 1$
				> 55	$\leq 2$
NS_10		20	15, 20	Table 6.2.4-3	Table 6.2.4-3
NS_11	6.6.2.2.1	23 <sup>1</sup>	1.4, 3, 5, 10	Table 6.2.4-5	Table 6.2.4-5
..					
NS_32	-	-	-	-	-

Note 1: Applies to the lower block of Band 23, i.e. a carrier placed in the 2000-2010 MHz region.

4.2 LTE BAND 2

**OUTPUT POWER FOR LTE BAND 2 (1.4MHZ)**

Band	Band Width	Channel	Frequency (MHz)	Modulation	RB Configuration		Average Power(dBm)	Peak Power(dBm)
					RB Size	RB Offset		
Band 2	1.4MHz	18607	1850.7	QPSK	1	Low	23.11	28.36
					1	Mid	23.98	29.67
					1	High	23.95	29.61
					3	Low	23.88	29.74
					3	High	23.84	29.45
					6	Low	22.90	29.75
				16QAM	1	Low	23.29	29.16
					1	Mid	23.18	29.09
					1	High	23.18	29.05
					3	Low	23.19	29.20
					3	High	23.27	29.32
					6	Low	22.21	29.34
	1.4MHz	18900	1880.0	QPSK	1	Low	23.73	28.08
					1	Mid	23.75	28.14
					1	High	23.71	28.19
					3	Low	23.70	28.46
					3	High	23.71	28.56
					6	Low	22.99	28.40
				16QAM	1	Low	23.22	27.91
					1	Mid	22.98	27.73
					1	High	23.20	28.00
					3	Low	23.11	28.63
					3	High	23.05	28.69
					6	Low	22.13	28.54
	1.4MHz	19193	1909.3	QPSK	1	Low	23.87	29.00
					1	Mid	23.78	28.64
					1	High	23.68	28.55
3					Low	23.82	28.90	
3					High	23.74	28.85	
6					Low	22.95	28.68	
16QAM				1	Low	23.29	28.19	
				1	Mid	23.23	28.01	
				1	High	23.22	27.96	
				3	Low	23.19	29.19	
				3	High	23.11	28.92	
				6	Low	22.22	28.92	

**OUTPUT POWER FOR LTE BAND 2 (3.0MHZ)**

Band	Band Width	Channel	Frequency (MHz)	Modulation	RB Configuration		Average Power(dBm)	Peak Power(dBm)
					RB Size	RB Offset		
Band 2	3.0 MHz	18615	1851.5	QPSK	1	Low	23.80	28.67
					1	Mid	23.69	28.49
					1	High	23.40	28.32
					8	Low	23.09	28.87
					8	High	22.99	28.48
					15	Low	22.94	29.05
				16QAM	1	Low	23.54	29.32
					1	Mid	23.40	28.99
					1	High	23.33	29.06
					8	Low	22.38	29.02
					8	High	22.30	28.85
					15	Low	22.12	28.95
	3.0 MHz	18900	1880.0	QPSK	1	Low	23.57	27.49
					1	Mid	23.45	27.93
					1	High	23.51	28.12
					8	Low	23.02	28.07
					8	High	23.05	28.38
					15	Low	23.00	29.16
				16QAM	1	Low	23.25	27.69
					1	Mid	23.20	27.98
					1	High	23.18	28.19
					8	Low	22.23	27.90
					8	High	22.22	27.77
					15	Low	22.15	28.53
	3.0 MHz	19185	1908.5	QPSK	1	Low	23.99	28.39
					1	Mid	23.79	28.53
					1	High	23.68	28.21
8					Low	23.23	28.67	
8					High	23.09	28.58	
15					Low	22.90	28.87	
16QAM				1	Low	23.71	29.13	
				1	Mid	23.62	29.27	
				1	High	23.43	28.87	
				8	Low	22.55	28.87	
				8	High	22.40	28.86	
				15	Low	22.28	28.88	

**OUTPUT POWER FOR LTE BAND 2 (5.0MHZ)**

Band	Band Width	Channel	Frequency (MHz)	Modulation	RB Configuration		Average Power(dBm)	Peak Power(dBm)
					RB Size	RB Offset		
Band 2	5.0 MHz	18625	1852.5	QPSK	1	Low	23.86	29.27
					1	Mid	23.53	29.01
					1	High	23.43	29.06
					12	Low	23.11	28.93
					12	High	22.99	28.83
					25	Low	23.09	29.12
				16QAM	1	Low	23.00	28.77
					1	Mid	22.79	28.55
					1	High	22.74	28.61
					12	Low	22.22	29.16
					12	High	22.10	29.09
					25	Low	22.15	29.60
	5.0 MHz	18900	1880.0	QPSK	1	Low	23.45	27.56
					1	Mid	23.40	28.01
					1	High	23.44	28.36
					12	Low	23.10	27.87
					12	High	23.05	28.43
					25	Low	23.03	28.60
				16QAM	1	Low	23.18	27.82
					1	Mid	23.11	28.35
					1	High	23.17	28.83
					12	Low	22.20	27.82
					12	High	22.15	28.27
					25	Low	22.15	28.48
	5.0 MHz	19175	1907.5	QPSK	1	Low	23.99	28.38
					1	Mid	23.73	28.67
					1	High	23.48	28.41
12					Low	23.38	28.90	
12					High	23.13	29.06	
25					Low	23.23	29.33	
16QAM				1	Low	23.66	28.45	
				1	Mid	23.43	28.74	
				1	High	23.25	28.64	
				12	Low	22.57	28.61	
				12	High	22.39	28.72	
				25	Low	22.38	29.86	

**OUTPUT POWER FOR LTE BAND 2 (10.0MHZ)**

Band	Band Width	Channel	Frequency (MHz)	Modulation	RB Configuration		Average Power(dBm)	Peak Power(dBm)
					RB Size	RB Offset		
Band 2	10.0 MHz	18650	1855.0	QPSK	1	Low	23.73	28.58
					1	Mid	23.38	28.37
					1	High	23.24	28.42
					25	Low	23.16	29.01
					25	High	22.91	28.99
					50	Low	23.06	29.28
				16QAM	1	Low	23.78	29.15
					1	Mid	23.37	29.11
					1	High	23.27	29.56
					25	Low	22.27	28.99
					25	High	22.10	28.98
					50	Low	22.11	29.50
	10.0 MHz	18900	1880.0	QPSK	1	Low	23.83	27.50
					1	Mid	23.53	27.94
					1	High	23.64	28.50
					25	Low	23.18	27.58
					25	High	23.11	28.89
					50	Low	23.16	28.65
				16QAM	1	Low	23.39	27.57
					1	Mid	22.97	27.83
					1	High	23.29	28.37
					25	Low	22.28	27.63
					25	High	22.23	28.88
					50	Low	22.30	28.87
	10.0 MHz	19150	1905.0	QPSK	1	Low	23.97	28.59
					1	Mid	23.74	28.21
					1	High	23.61	28.55
25					Low	23.59	28.65	
25					High	23.25	28.69	
50					Low	23.41	29.27	
16QAM				1	Low	23.99	28.25	
				1	Mid	23.49	27.76	
				1	High	23.38	28.29	
				25	Low	22.68	28.80	
				25	High	22.35	28.99	
				50	Low	22.49	29.18	



**OUTPUT POWER FOR LTE BAND 2 (15.0MHZ)**

Band	Band Width	Channel	Frequency (MHz)	Modulation	RB Configuration		Average Power(dBm)	Peak Power(dBm)
					RB Size	RB Offset		
Band 2	15.0 MHz	18675	1857.5	QPSK	1	Low	23.80	28.82
					1	Mid	23.37	28.49
					1	High	23.45	28.37
					36	Low	23.47	29.27
					36	High	23.12	29.27
					75	Low	23.23	29.91
				16QAM	1	Low	23.86	29.28
					1	Mid	23.44	29.42
					1	High	23.54	29.42
					36	Low	22.44	29.29
					36	High	22.19	29.72
					75	Low	22.12	29.45
	15.0 MHz	18900	1880.0	QPSK	1	Low	24.00	27.74
					1	Mid	23.51	27.76
					1	High	23.73	28.56
					36	Low	23.32	27.80
					36	High	23.17	28.98
					75	Low	23.22	29.33
				16QAM	1	Low	23.95	27.76
					1	Mid	23.35	27.88
					1	High	23.66	28.82
					36	Low	22.34	27.71
					36	High	22.22	29.05
					75	Low	22.27	28.87
	15.0 MHz	19125	1902.5	QPSK	1	Low	23.98	29.62
					1	Mid	23.73	28.10
					1	High	23.62	28.54
36					Low	23.73	28.87	
36					High	23.34	28.92	
75					Low	23.61	30.09	
16QAM				1	Low	23.94	29.25	
				1	Mid	23.49	27.67	
				1	High	23.37	28.09	
				36	Low	22.84	29.21	
				36	High	22.40	28.87	
				75	Low	22.65	29.83	

**OUTPUT POWER FOR LTE BAND 2 (20.0MHZ)**

Band	Band Width	Channel	Frequency (MHz)	Modulation	RB Configuration		Average Power(dBm)	Peak Power(dBm)
					RB Size	RB Offset		
Band 2	20.0 MHz	18700	1860.0	QPSK	1	Low	23.99	29.04
					1	Mid	23.31	28.77
					1	High	23.30	28.04
					50	Low	23.55	29.09
					50	High	22.95	29.04
					100	Low	23.13	29.32
				16QAM	1	Low	23.89	29.16
					1	Mid	23.05	29.13
					1	High	23.03	28.04
					50	Low	22.51	29.04
					50	High	22.06	29.20
					100	Low	22.24	29.84
	20.0 MHz	18900	1880.0	QPSK	1	Low	23.94	28.06
					1	Mid	23.36	28.07
					1	High	23.50	28.76
					50	Low	23.69	27.80
					50	High	23.15	28.81
					100	Low	23.34	29.40
				16QAM	1	Low	23.98	28.11
					1	Mid	23.52	28.09
					1	High	23.63	29.23
					50	Low	22.47	27.65
					50	High	22.25	28.96
					100	Low	22.36	29.22
	20.0 MHz	19100	1900.0	QPSK	1	Low	23.98	29.32
					1	Mid	23.66	28.07
					1	High	23.27	28.26
50					Low	23.67	29.46	
50					High	23.20	28.94	
100					Low	23.50	29.52	
16QAM				1	Low	23.98	29.99	
				1	Mid	23.55	28.86	
				1	High	23.05	29.02	
				50	Low	22.70	29.38	
				50	High	22.24	28.93	
				100	Low	22.48	29.53	

### 4.3 LTE BAND 4

#### OUTPUT POWER FOR LTE BAND 4 (1.4MHZ)

Band	Band Width	Channel	Frequency (MHz)	Modulation	RB Configuration		Average Power(dBm)	Peak Power(dBm)
					RB Size	RB Offset		
Band 4	1.4MHz	19957	1710.7	QPSK	1	Low	23.27	29.47
					1	Mid	23.21	29.48
					1	High	23.26	29.83
					3	Low	23.43	30.01
					3	High	23.39	29.92
					6	Low	22.73	29.49
				16QAM	1	Low	22.89	29.62
					1	Mid	22.90	29.68
					1	High	22.84	29.53
					3	Low	22.88	29.60
					3	High	22.89	29.92
					6	Low	21.79	29.60
	1.4MHz	20175	1732.5	QPSK	1	Low	23.36	28.62
					1	Mid	23.37	28.55
					1	High	23.39	28.64
					3	Low	23.41	29.11
					3	High	23.45	29.22
					6	Low	22.68	28.59
				16QAM	1	Low	22.83	28.42
					1	Mid	22.74	28.24
					1	High	22.87	28.46
					3	Low	22.75	29.28
					3	High	22.72	29.23
					6	Low	21.76	28.75
	1.4MHz	20393	1754.3	QPSK	1	Low	23.69	29.33
					1	Mid	23.76	29.13
					1	High	23.68	28.96
					3	Low	23.75	29.08
					3	High	23.72	29.33
					6	Low	22.85	28.69
16QAM				1	Low	22.95	28.61	
				1	Mid	22.95	28.54	
				1	High	22.91	28.46	
				3	Low	22.94	29.83	
				3	High	22.93	29.54	
				6	Low	21.98	28.75	

**OUTPUT POWER FOR LTE BAND 4 (3.0MHZ)**

Band	Band Width	Channel	Frequency (MHz)	Modulation	RB Configuration		Average Power(dBm)	Peak Power(dBm)
					RB Size	RB Offset		
Band 4	3.0 MHz	19965	1711.5	QPSK	1	Low	23.51	29.15
					1	Mid	23.48	29.23
					1	High	23.45	29.04
					8	Low	22.69	28.97
					8	High	22.74	29.01
					15	Low	22.74	29.24
				16QAM	1	Low	23.28	29.92
					1	Mid	23.23	30.26
					1	High	23.06	29.86
					8	Low	22.05	29.25
					8	High	21.98	29.18
					15	Low	21.85	29.37
	3.0 MHz	20175	1732.5	QPSK	1	Low	23.49	28.63
					1	Mid	23.39	28.64
					1	High	23.35	28.50
					8	Low	22.80	28.87
					8	High	22.74	28.83
					15	Low	22.63	29.31
				16QAM	1	Low	22.80	28.34
					1	Mid	22.69	28.31
					1	High	22.75	28.36
					8	Low	21.93	28.38
					8	High	21.92	28.15
					15	Low	21.85	28.86
	3.0 MHz	20385	1753.5	QPSK	1	Low	23.72	29.17
					1	Mid	23.65	29.34
					1	High	23.63	29.12
8					Low	22.95	29.18	
8					High	22.89	29.10	
15					Low	22.94	29.30	
16QAM				1	Low	23.18	28.53	
				1	Mid	23.10	28.47	
				1	High	23.12	28.42	
				8	Low	22.00	28.51	
				8	High	22.05	28.59	
				15	Low	21.92	29.57	

**OUTPUT POWER FOR LTE BAND 4 (5.0MHZ)**

Band	Band Width	Channel	Frequency (MHz)	Modulation	RB Configuration		Average Power(dBm)	Peak Power(dBm)
					RB Size	RB Offset		
Band 4	5.0 MHz	19975	1712.5	QPSK	1	Low	23.75	30.41
					1	Mid	23.53	30.00
					1	High	23.54	29.97
					12	Low	22.75	29.13
					12	High	22.68	29.18
					25	Low	22.75	29.31
				16QAM	1	Low	22.75	29.32
					1	Mid	22.55	28.82
					1	High	22.53	29.12
					12	Low	21.89	29.63
					12	High	21.82	29.59
					25	Low	21.80	29.89
	5.0 MHz	20175	1732.5	QPSK	1	Low	23.50	29.08
					1	Mid	23.43	28.87
					1	High	23.38	28.87
					12	Low	22.79	28.66
					12	High	22.68	28.43
					25	Low	22.74	28.75
				16QAM	1	Low	22.86	29.20
					1	Mid	22.72	28.99
					1	High	22.72	29.10
					12	Low	21.80	28.69
					12	High	21.79	28.41
					25	Low	21.81	29.44
	5.0 MHz	20375	1752.5	QPSK	1	Low	23.83	29.36
					1	Mid	23.70	29.08
					1	High	23.68	29.11
12					Low	22.91	29.67	
12					High	22.88	29.18	
25					Low	22.87	28.98	
16QAM				1	Low	23.13	29.57	
				1	Mid	23.07	29.22	
				1	High	22.99	29.22	
				12	Low	22.16	29.07	
				12	High	22.11	28.93	
				25	Low	22.03	29.33	

**OUTPUT POWER FOR LTE BAND 4 (10.0MHZ)**

Band	Band Width	Channel	Frequency (MHz)	Modulation	RB Configuration		Average Power(dBm)	Peak Power(dBm)
					RB Size	RB Offset		
Band 4	10.0 MHz	20000	1715.0	QPSK	1	Low	23.89	29.54
					1	Mid	23.31	28.66
					1	High	23.42	28.90
					25	Low	22.87	29.53
					25	High	22.66	29.33
					50	Low	22.78	29.41
				16QAM	1	Low	23.58	30.31
					1	Mid	23.14	30.04
					1	High	23.18	30.02
					25	Low	22.03	29.63
					25	High	21.80	29.48
					50	Low	21.81	29.98
	10.0 MHz	20175	1732.5	QPSK	1	Low	23.76	29.15
					1	Mid	23.40	28.57
					1	High	23.50	28.72
					25	Low	22.85	29.19
					25	High	22.76	28.99
					50	Low	22.78	28.75
				16QAM	1	Low	23.13	28.91
					1	Mid	22.69	28.22
					1	High	22.87	28.39
					25	Low	21.97	28.97
					25	High	21.87	28.87
					50	Low	21.87	29.42
	10.0 MHz	20350	1750.0	QPSK	1	Low	23.91	29.59
					1	Mid	23.60	29.15
					1	High	23.71	29.16
25					Low	22.98	29.33	
25					High	22.89	29.14	
50					Low	22.97	29.28	
16QAM				1	Low	23.39	28.66	
				1	Mid	23.05	28.34	
				1	High	23.15	28.57	
				25	Low	22.12	29.71	
				25	High	21.99	29.35	
				50	Low	22.00	29.13	

**OUTPUT POWER FOR LTE BAND 4 (15.0MHZ)**

Band	Band Width	Channel	Frequency (MHz)	Modulation	RB Configuration		Average Power(dBm)	Peak Power(dBm)
					RB Size	RB Offset		
Band 4	15.0 MHz	20025	1717.5	QPSK	1	Low	23.80	29.71
					1	Mid	23.37	28.79
					1	High	23.49	28.92
					36	Low	23.05	29.63
					36	High	22.75	29.34
					75	Low	22.88	30.00
				16QAM	1	Low	23.84	30.47
					1	Mid	23.10	29.96
					1	High	23.22	29.84
					36	Low	22.02	29.91
					36	High	21.79	29.68
					75	Low	21.89	29.57
	15.0 MHz	20175	1732.5	QPSK	1	Low	23.83	29.21
					1	Mid	23.42	28.38
					1	High	23.60	28.69
					36	Low	22.91	29.08
					36	High	22.78	28.85
					75	Low	22.84	29.43
				16QAM	1	Low	23.61	29.04
					1	Mid	23.02	28.33
					1	High	23.13	28.41
					36	Low	22.02	29.25
					36	High	21.82	28.88
					75	Low	21.88	29.15
	15.0 MHz	20325	1747.5	QPSK	1	Low	23.94	29.36
					1	Mid	23.61	29.13
					1	High	23.71	29.16
36					Low	23.11	29.27	
36					High	22.95	29.32	
75					Low	22.96	29.95	
16QAM				1	Low	23.59	28.65	
				1	Mid	23.09	28.32	
				1	High	23.17	28.70	
				36	Low	22.17	29.64	
				36	High	21.91	29.66	
				75	Low	22.03	29.53	

**OUTPUT POWER FOR LTE BAND 4 (20.0MHZ)**

Band	Band Width	Channel	Frequency (MHz)	Modulation	RB Configuration		Average Power(dBm)	Peak Power(dBm)
					RB Size	RB Offset		
Band 4	20.0 MHz	20050	1720.0	QPSK	1	Low	23.98	29.98
					1	Mid	23.28	29.10
					1	High	23.24	28.86
					50	Low	22.93	29.61
					50	High	22.59	29.28
					100	Low	22.77	29.58
				16QAM	1	Low	23.44	29.87
					1	Mid	22.74	29.17
					1	High	22.68	28.78
					50	Low	22.04	29.74
					50	High	21.62	29.53
					100	Low	21.86	30.34
	20.0 MHz	20175	1732.5	QPSK	1	Low	24.00	29.68
					1	Mid	23.30	28.66
					1	High	23.43	29.00
					50	Low	22.98	29.06
					50	High	22.70	28.73
					100	Low	22.78	29.22
				16QAM	1	Low	23.72	29.60
					1	Mid	23.02	28.53
					1	High	23.17	28.93
					50	Low	22.03	29.10
					50	High	21.76	28.78
					100	Low	21.91	29.16
	20.0 MHz	20300	1745.0	QPSK	1	Low	23.99	29.01
					1	Mid	23.49	28.91
					1	High	23.71	28.98
50					Low	22.97	29.15	
50					High	22.84	29.39	
100					Low	22.97	29.55	
16QAM				1	Low	23.53	29.25	
				1	Mid	22.88	29.56	
				1	High	23.07	29.73	
				50	Low	22.13	28.93	
				50	High	21.88	29.39	
				100	Low	21.98	29.61	



4.4 LTE BAND 13

**OUTPUT POWER FOR LTE BAND 13 (5MHZ)**

Band	Band Width	Channel	Frequency (MHz)	Modulation	RB Configuration		Average Power(dBm)	Peak Power(dBm)
					RB Size	RB Offset		
Band 13	5MHz	23205	779.5	QPSK	1	Low	23.85	29.82
					1	Mid	23.99	29.00
					1	High	23.98	30.30
					12	Low	23.28	29.01
					12	High	23.30	29.00
					25	Low	23.39	29.40
				16QAM	1	Low	23.10	29.24
					1	Mid	23.12	28.55
					1	High	23.08	29.29
					12	Low	22.27	29.35
					12	High	22.48	29.18
					25	Low	22.40	29.61
	5MHz	23230	782	QPSK	1	Low	23.94	29.25
					1	Mid	23.98	30.21
					1	High	23.81	30.52
					12	Low	23.27	29.09
					12	High	23.22	29.44
					25	Low	23.26	29.64
				16QAM	1	Low	23.07	28.75
					1	Mid	23.07	29.12
					1	High	22.92	29.20
					12	Low	22.47	29.24
					12	High	22.32	30.11
					25	Low	22.41	29.58
	5MHz	23255	784.5	QPSK	1	Low	24.00	29.91
					1	Mid	23.94	29.76
					1	High	23.79	29.02
12					Low	23.40	29.61	
12					High	23.23	29.08	
25					Low	23.25	29.63	
16QAM				1	Low	23.36	29.92	
				1	Mid	23.30	30.08	
				1	High	23.19	29.11	
				12	Low	22.28	29.17	
				12	High	22.27	29.15	
				25	Low	22.25	29.80	



**OUTPUT POWER FOR LTE BAND 13 (10MHZ)**

Band	Band Width	Channel	Frequency (MHz)	Modulation	RB Configuration		Average Power(dBm)	Peak Power(dBm)
					RB Size	RB Offset		
Band 13	10 MHz	23230	782	QPSK	1	Low	23.79	29.09
					1	Mid	23.86	29.05
					1	High	23.44	28.62
					25	Low	23.37	29.45
					25	High	23.34	29.74
					50	Low	23.44	29.59
				16QAM	1	Low	23.59	29.74
					1	Mid	23.60	30.06
					1	High	23.15	29.11
					25	Low	22.41	29.44
					25	High	22.39	30.01
					50	Low	22.41	29.55



## 5. OCCUPIED BANDWIDTH

### RULE PART(S)

FCC: §2.1049

### LIMITS

For reporting purposes only

### TEST PROCEDURE

The transmitter output was connected to a calibrated coaxial cable and coupler, the other end of which was connected to a spectrum analyzer. The occupied bandwidth was measured with the spectrum analyzer at the low, middle and high channel in each band. The -26dB bandwidth was also measured and recorded.

### MODES TESTED

- LTE Band 2
- LTE Band 4
- LTE Band 13

### RESULTS

PASS

**Test results:**

Band	Mode	RB Size/RB Offset	Frequency (MHz)	99% Occupied Bandwidth (MHz)	-26dBc Occupied Bandwidth (MHz)
LTE Band 2	1.4MHz BAND QPSK	6/0	1880.0	1.09	1.29
	1.4MHz BAND 16QAM	6/0	1880.0	1.09	1.30
	3.0MHz BAND QPSK	15/0	1880.0	2.69	2.92
	3.0MHz BAND 16QAM	15/0	1880.0	2.69	2.93
	5.0MHz BAND QPSK	25/0	1880.0	4.49	4.86
	5.0MHz BAND 16QAM	25/0	1880.0	4.48	4.81
	10.0MHz BAND QPSK	50/0	1880.0	8.98	9.58
	10.0MHz BAND 16QAM	50/0	1880.0	8.97	9.56
	15.0MHz BAND QPSK	75/0	1880.0	13.48	14.30
	15.0MHz BAND 16QAM	75/0	1880.0	13.48	14.28
	20.0MHz BAND QPSK	100/0	1880.0	18.01	19.06
20.0MHz BAND 16QAM	100/0	1880.0	18.01	19.07	

Band	Mode	RB Size/RB Offset	Frequency (MHz)	99% Occupied Bandwidth (MHz)	-26dBc Occupied Bandwidth (MHz)
LTE Band 4	1.4MHz BAND QPSK	6/0	1732.5	1.09	1.33
	1.4MHz BAND 16QAM	6/0	1732.5	1.09	1.33
	3.0MHz BAND QPSK	15/0	1732.5	2.69	2.94
	3.0MHz BAND 16QAM	15/0	1732.5	2.69	2.95
	5.0MHz BAND QPSK	25/0	1732.5	4.49	4.86
	5.0MHz BAND 16QAM	25/0	1732.5	4.48	4.81
	10.0MHz BAND QPSK	50/0	1732.5	8.96	9.55
	10.0MHz BAND 16QAM	50/0	1732.5	8.96	9.53
	15.0MHz BAND QPSK	75/0	1732.5	13.43	14.27
	15.0MHz BAND 16QAM	75/0	1732.5	13.42	14.26
	20.0MHz BAND QPSK	100/0	1732.5	17.90	19.02
	20.0MHz BAND 16QAM	100/0	1732.5	17.89	19.02



Band	Mode	RB Size/RB Offset	Frequency (MHz)	99% Occupied Bandwidth (MHz)	-26dBc Occupied Bandwidth (MHz)
LTE Band 13	5.0MHz BAND QPSK	25/0	782.0	4.49	4.87
	5.0MHz BAND 16QAM	25/0	782.0	4.50	4.85
	10.0MHz BAND QPSK	50/0	782.0	8.97	9.52
	10.0MHz BAND 16QAM	50/0	782.0	8.97	9.51

Note: This test was only measured at maximum RB allocation and at CENTER of band for each LTE BW



### 5.1 LTE BAND 2

Band 2,UL Channel 18900,UL Frequency 1880.0,BW 1.4,NO. RB 6,RB POS. Low,QPSK

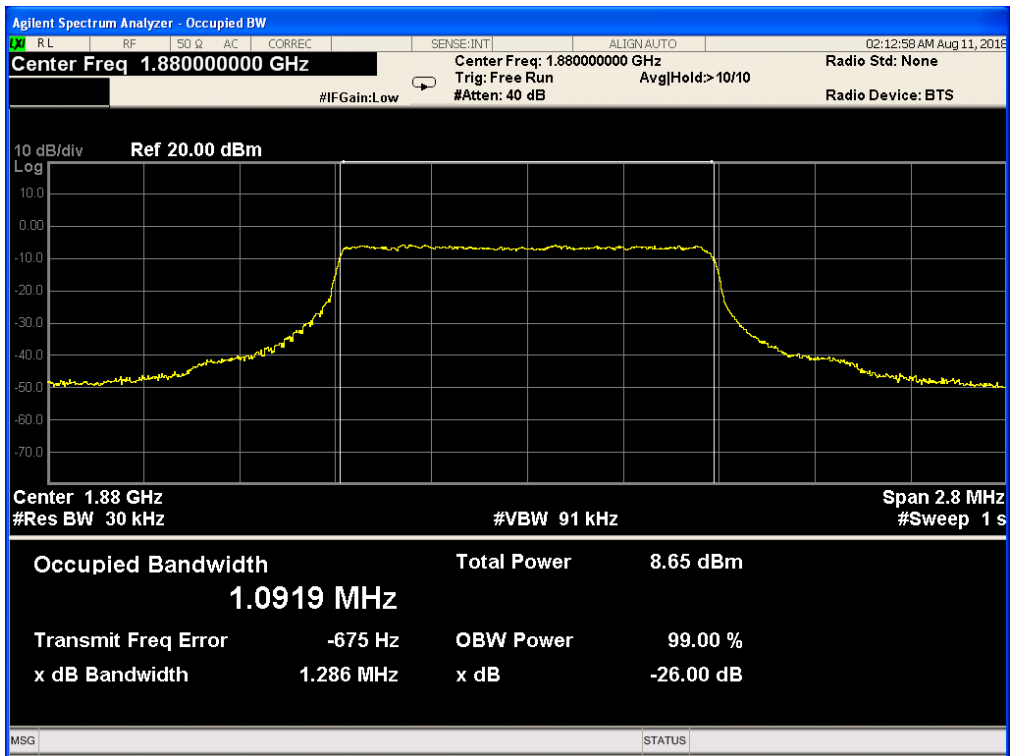

Band 2,UL Channel 18900,UL Frequency 1880.0,BW 1.4,NO. RB 6,RB POS. Low,16-QAM

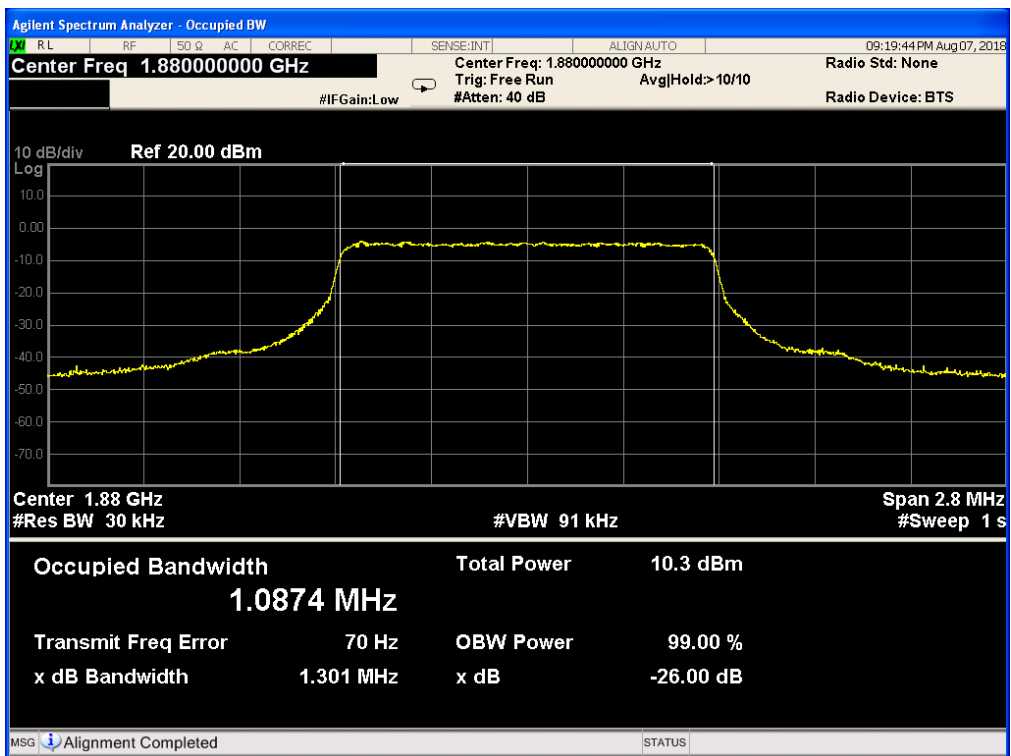



Band 2,UL Channel 18900,UL Frequency 1880.0,BW 3.0,NO. RB 15,RB POS. Low,QPSK

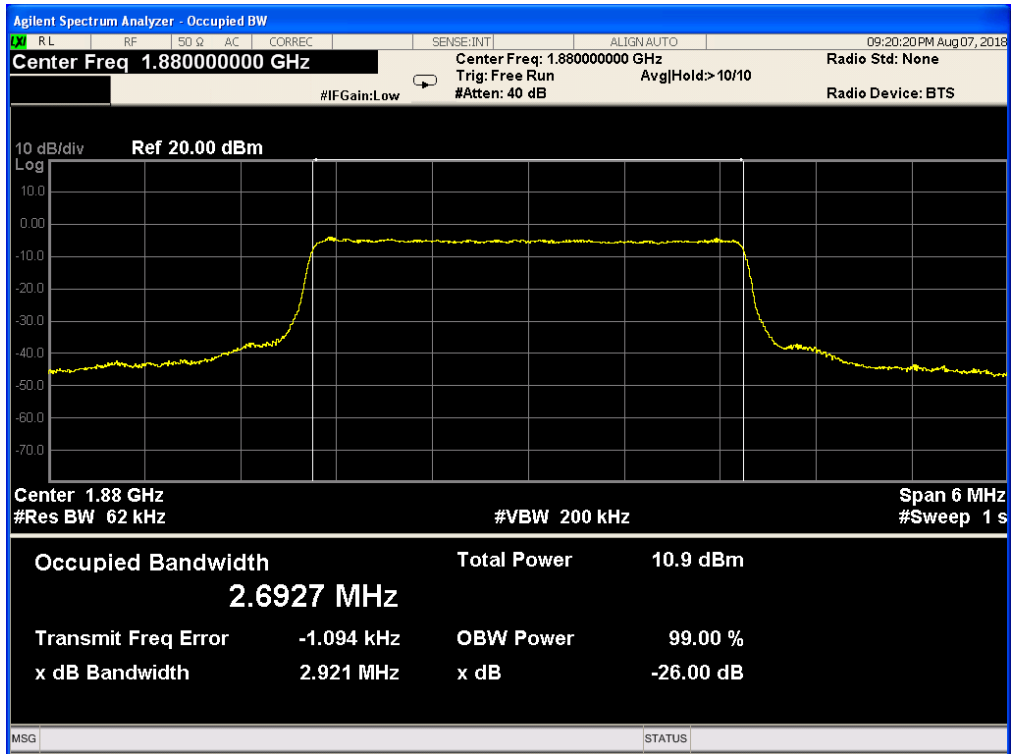

Band 2,UL Channel 18900,UL Frequency 1880.0,BW 3.0,NO. RB 15,RB POS. Low,16-QAM

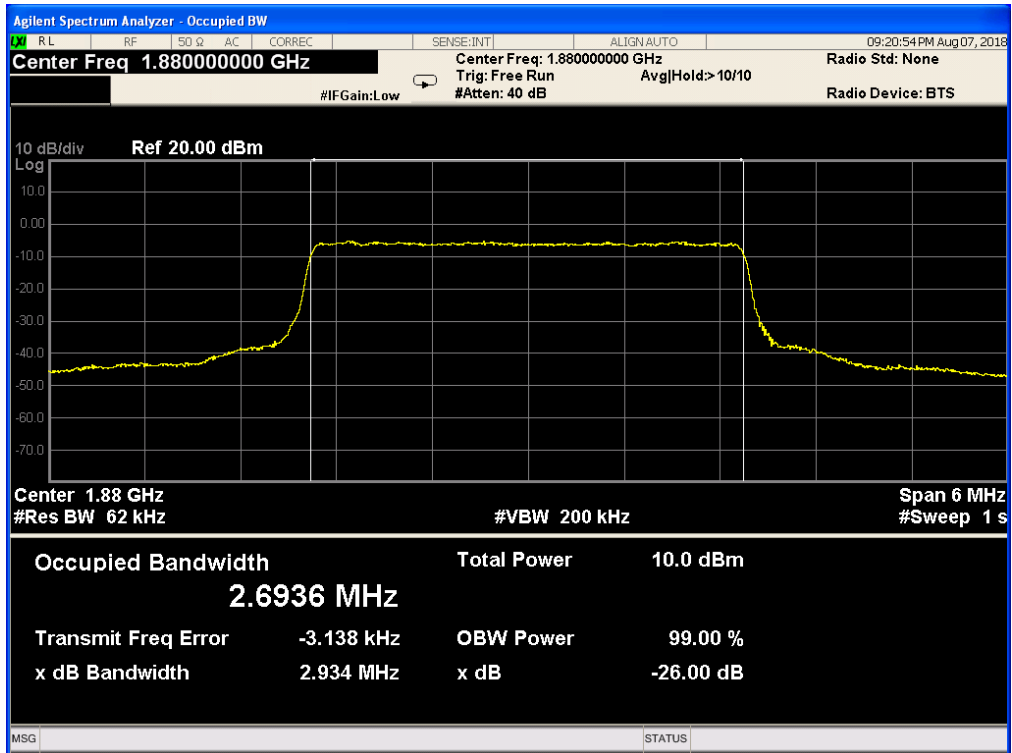



Band 2,UL Channel 18900,UL Frequency 1880.0,BW 5.0,NO. RB 25,RB POS. Low,QPSK

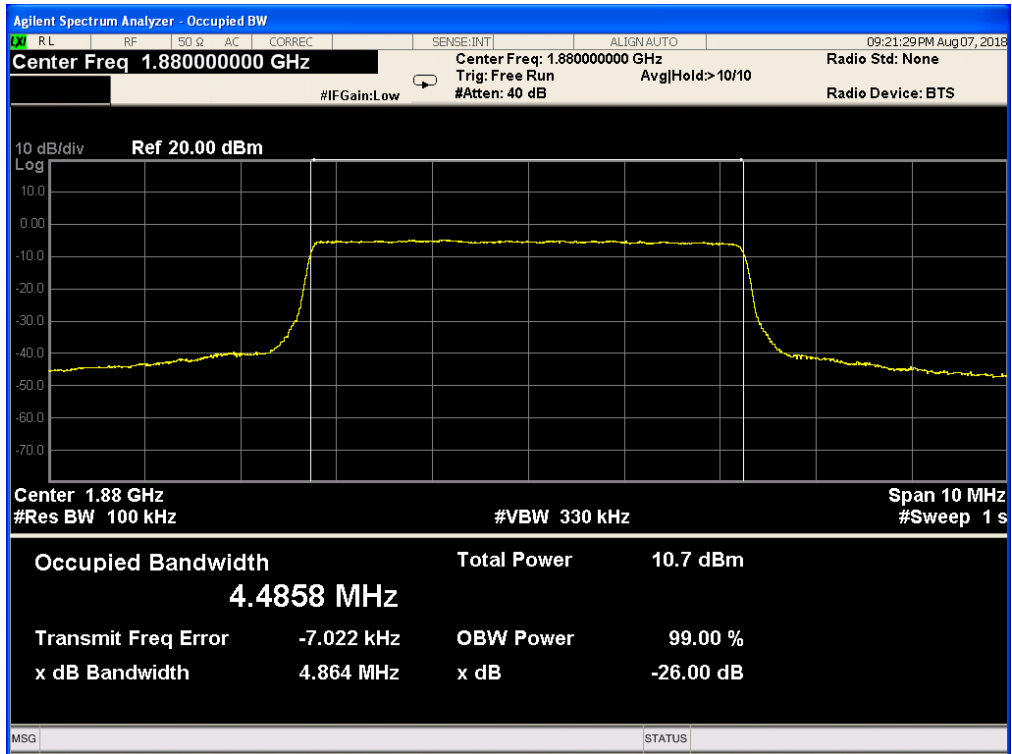

Band 2,UL Channel 18900,UL Frequency 1880.0,BW 5.0,NO. RB 25,RB POS. Low,16-QAM

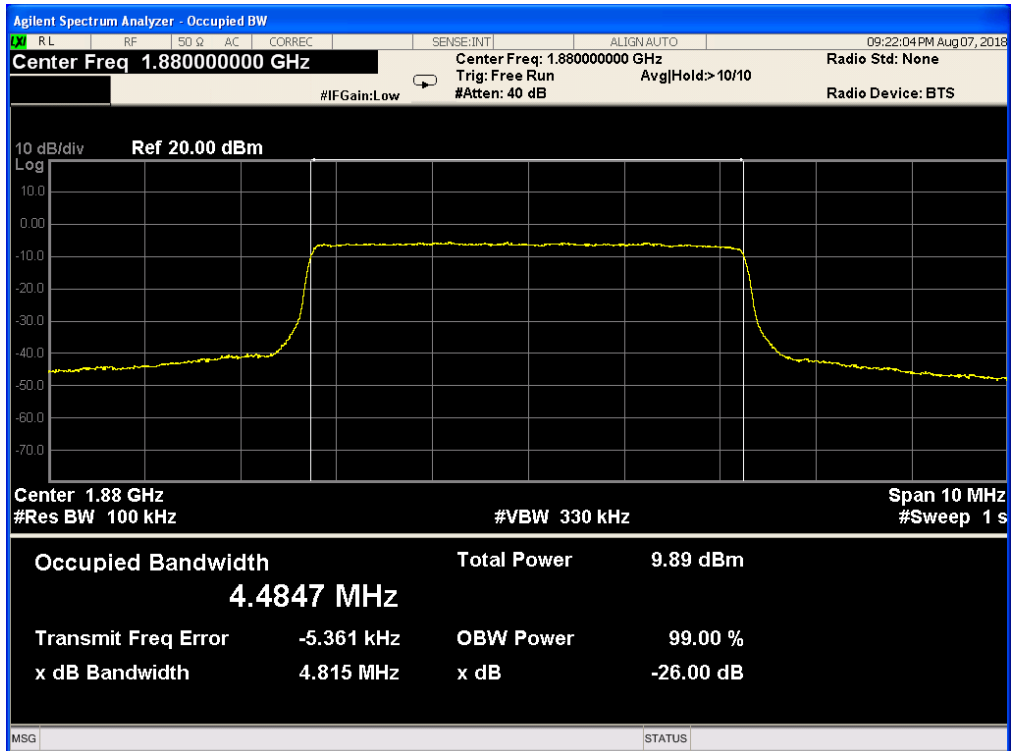





Band 2,UL Channel 18900,UL Frequency 1880.0,BW 10.0,NO. RB 50,RB POS. Low,QPSK

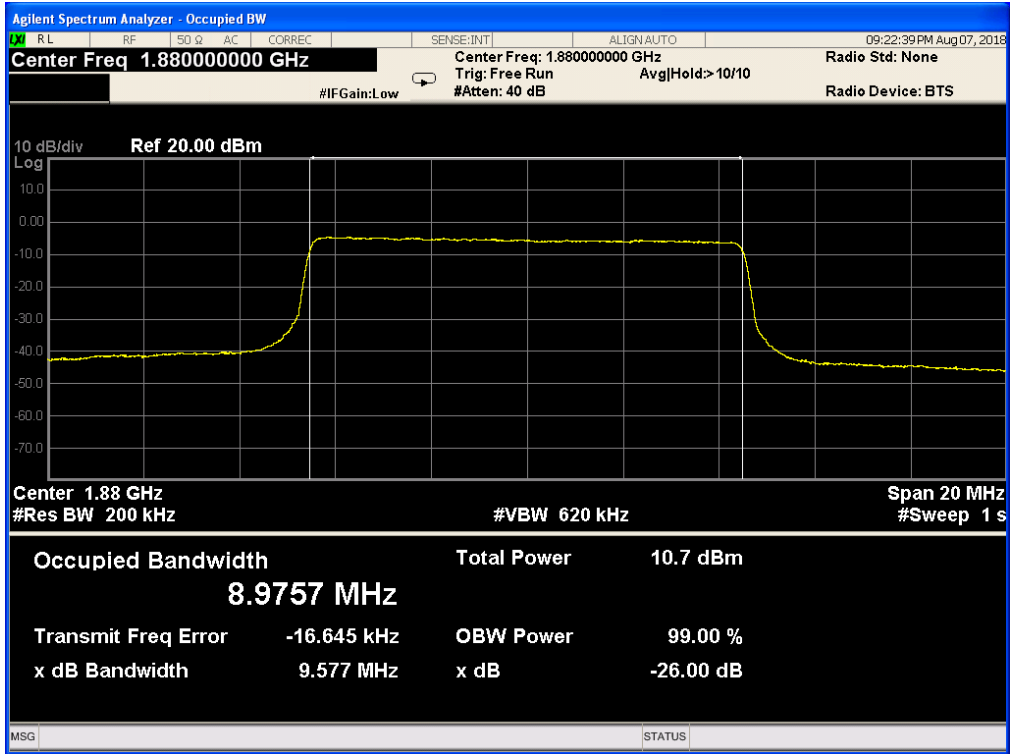

Band 2,UL Channel 18900,UL Frequency 1880.0,BW 10.0,NO. RB 50,RB POS. Low,16-QAM

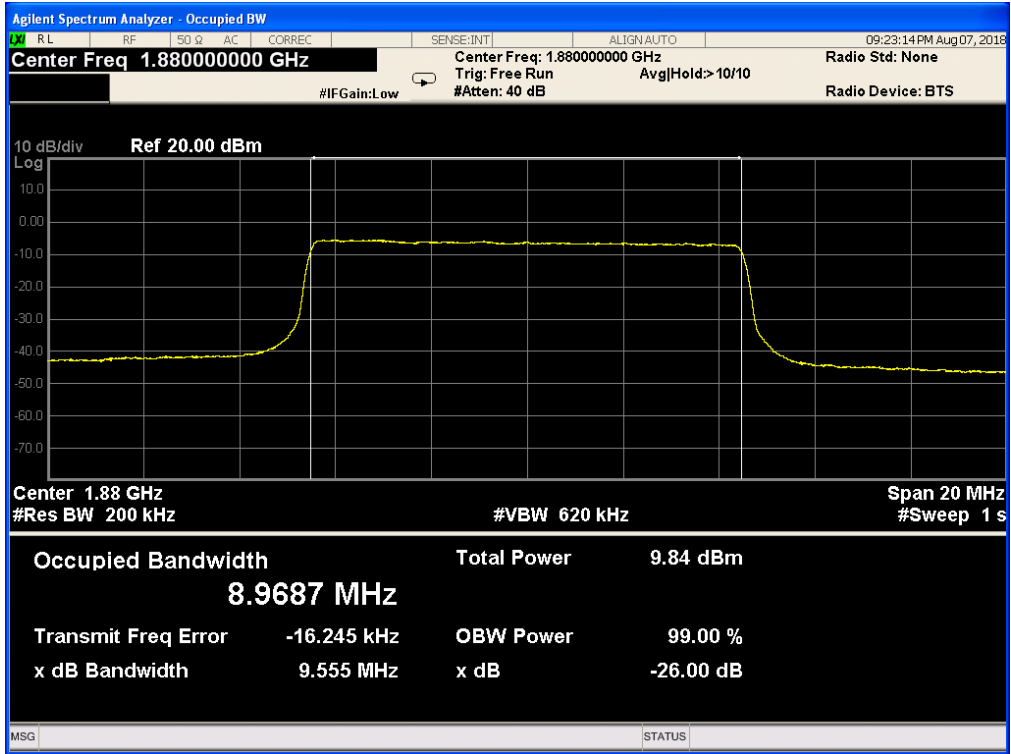



Band 2,UL Channel 18900,UL Frequency 1880.0,BW 15.0,NO. RB 75,RB POS. Low,QPSK

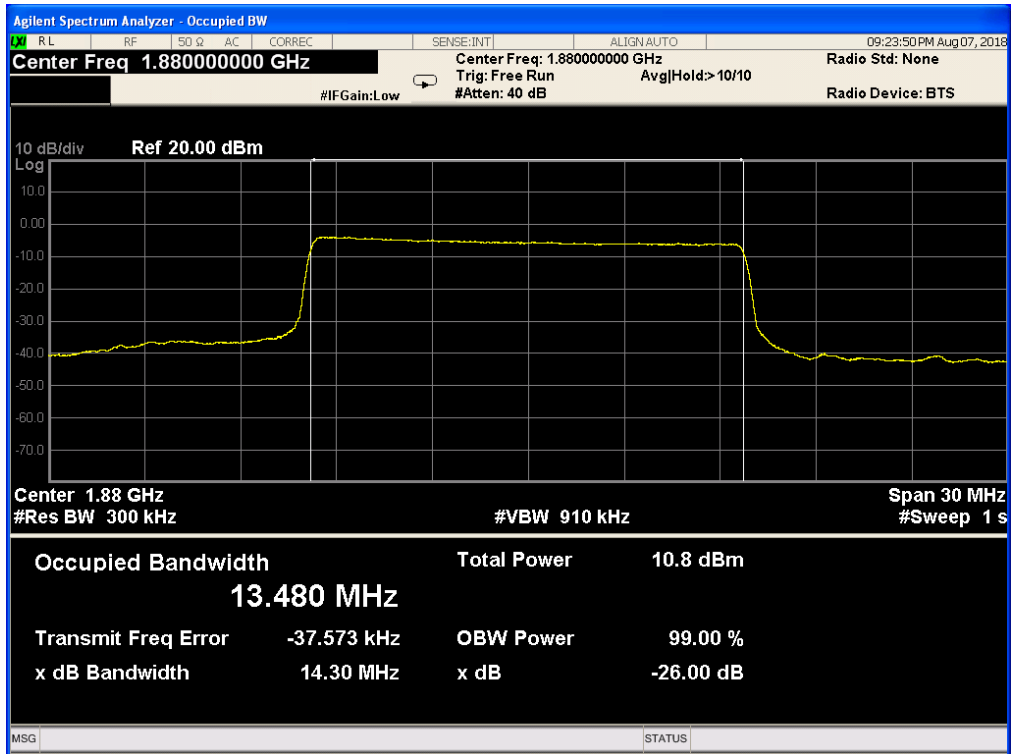

Band 2,UL Channel 18900,UL Frequency 1880.0,BW 15.0,NO. RB 75,RB POS. Low,16-QAM

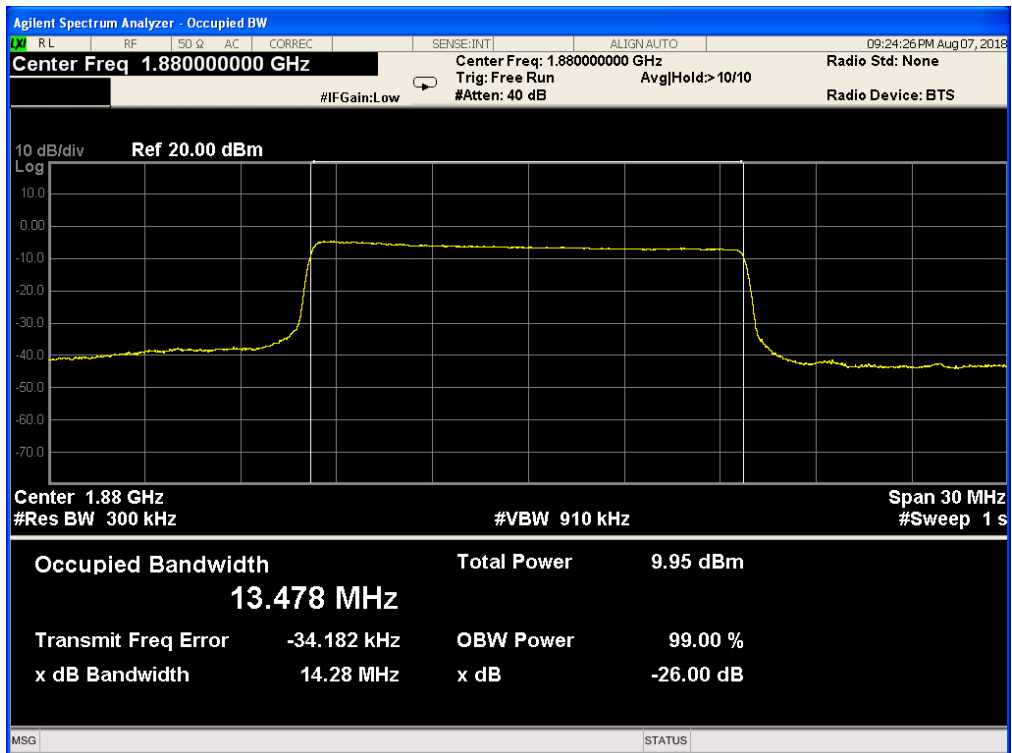



Band 2,UL Channel 18900,UL Frequency 1880.0,BW 20.0,NO. RB 100,RB POS. Low,QPSK

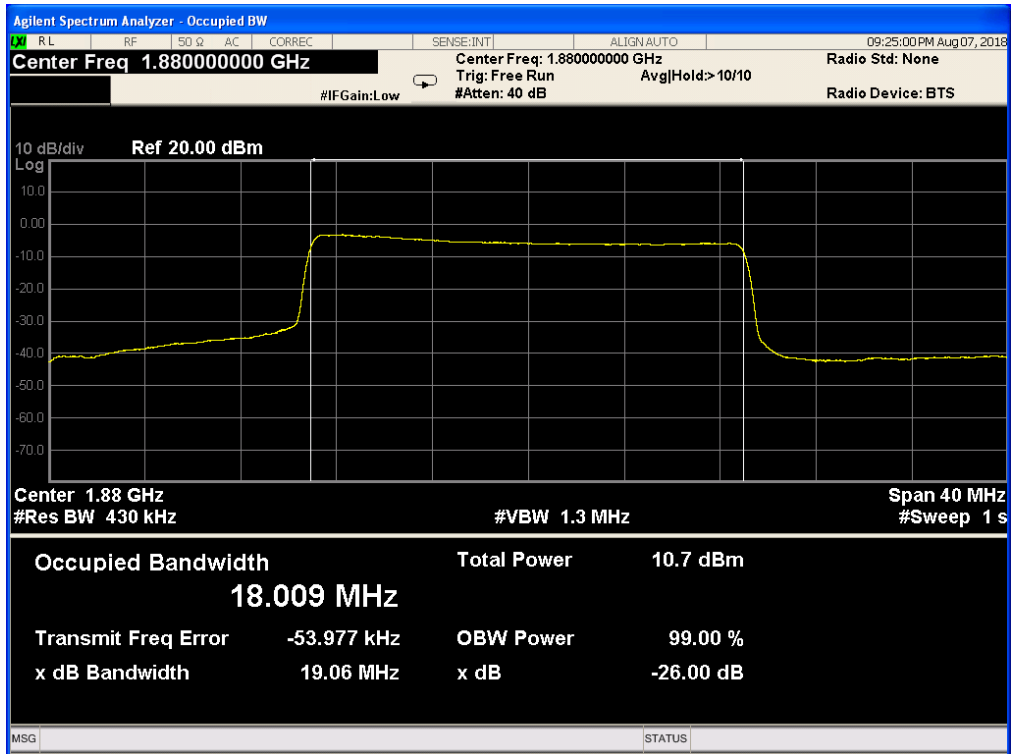

Band 2,UL Channel 18900,UL Frequency 1880.0,BW 20.0,NO. RB 100,RB POS. Low,16-QAM

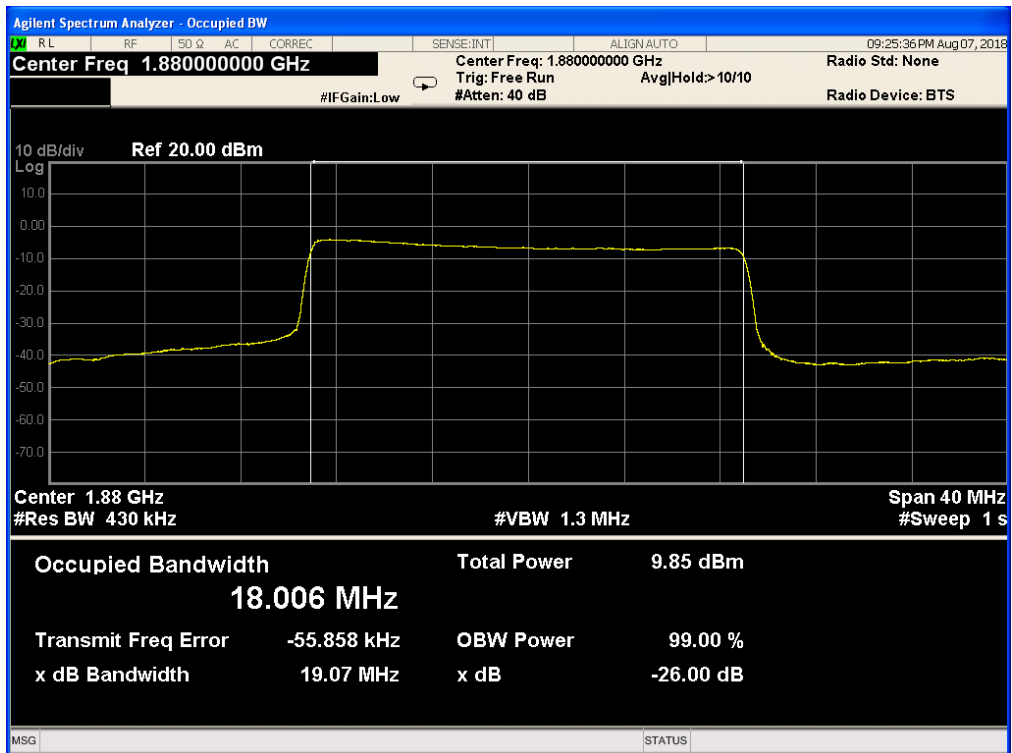



### 5.2 LTE BAND 4

Band 4,UL Channel 20175,UL Frequency 1732.5,BW 1.4,NO. RB 6,RB POS. Low,QPSK

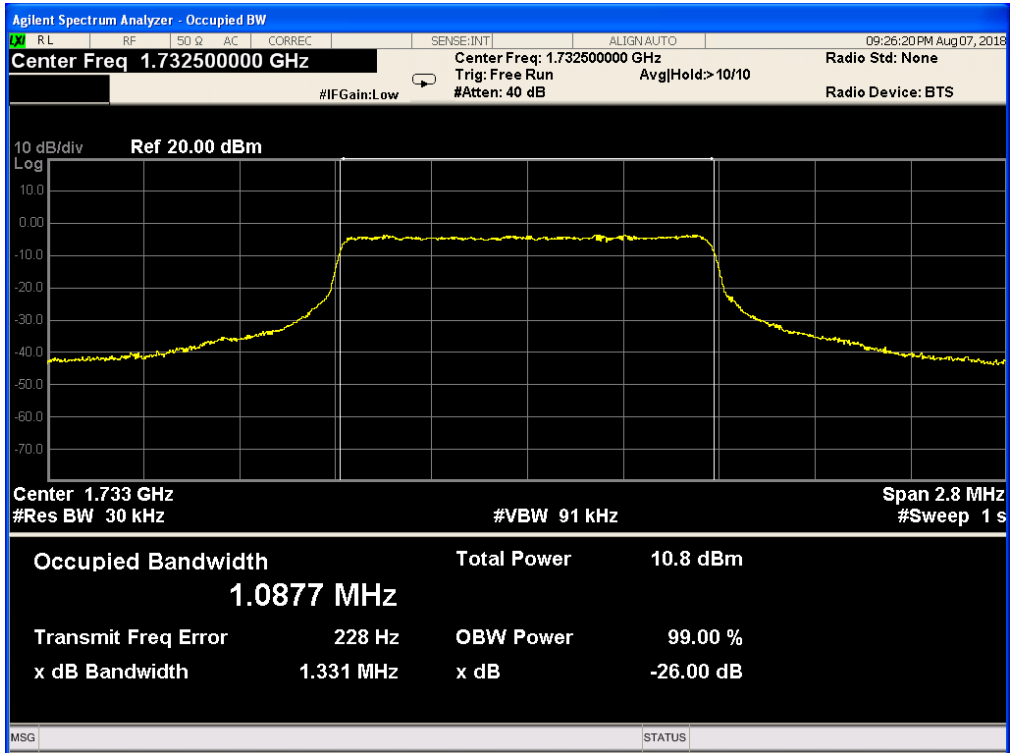

Band 4,UL Channel 20175,UL Frequency 1732.5,BW 1.4,NO. RB 6,RB POS. Low,16-QAM

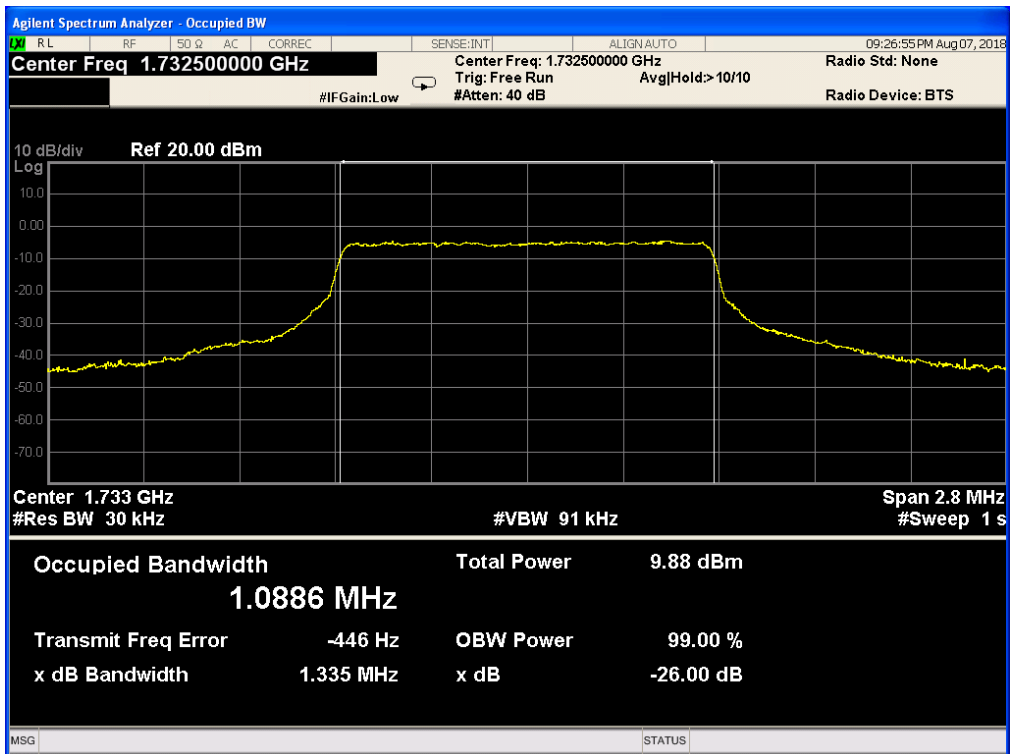



Band 4,UL Channel 20175,UL Frequency 1732.5,BW 3.0,NO. RB 15,RB POS. Low,QPSK

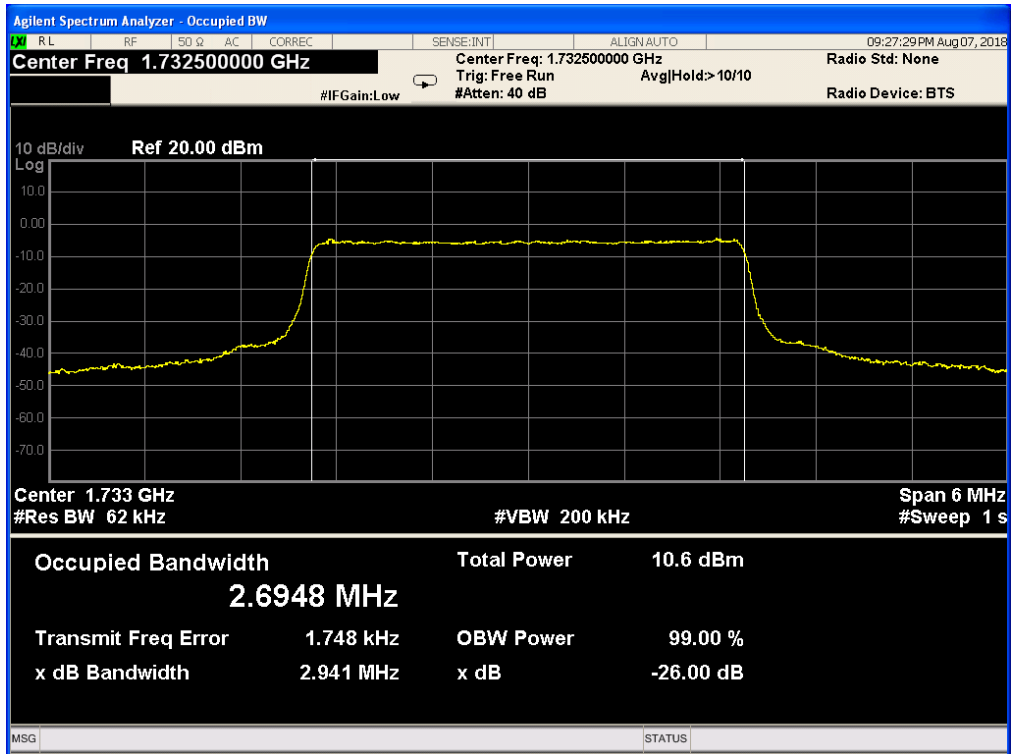

Band 4,UL Channel 20175,UL Frequency 1732.5,BW 3.0,NO. RB 15,RB POS. Low,16-QAM

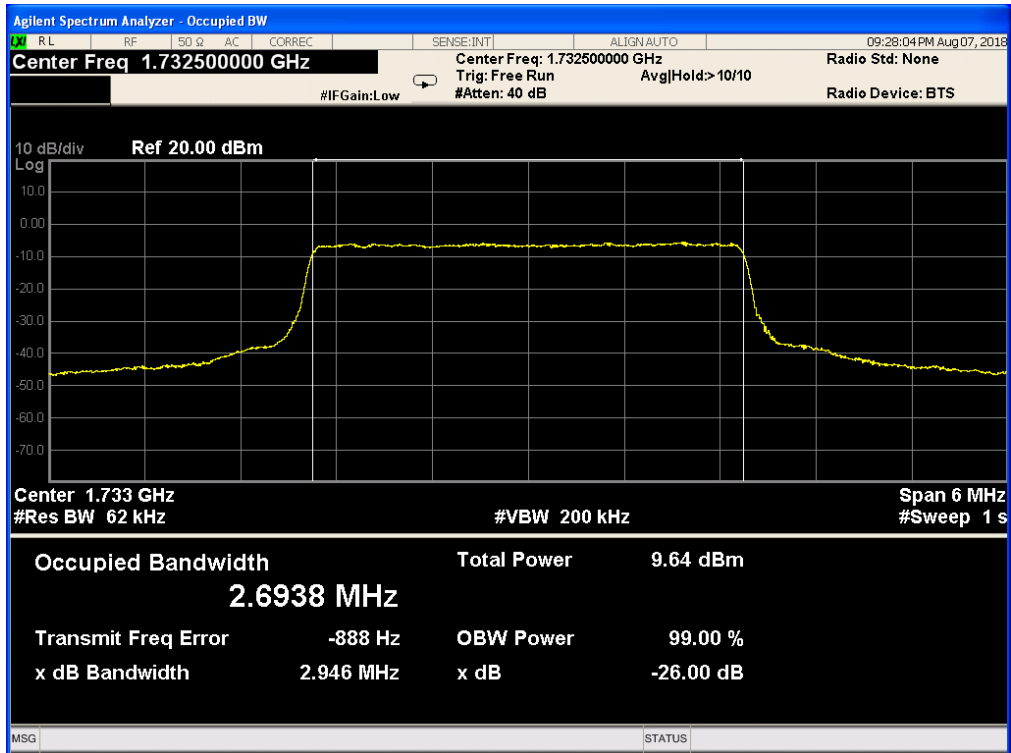



Band 4,UL Channel 20175,UL Frequency 1732.5,BW 5.0,NO. RB 25,RB POS. Low,QPSK

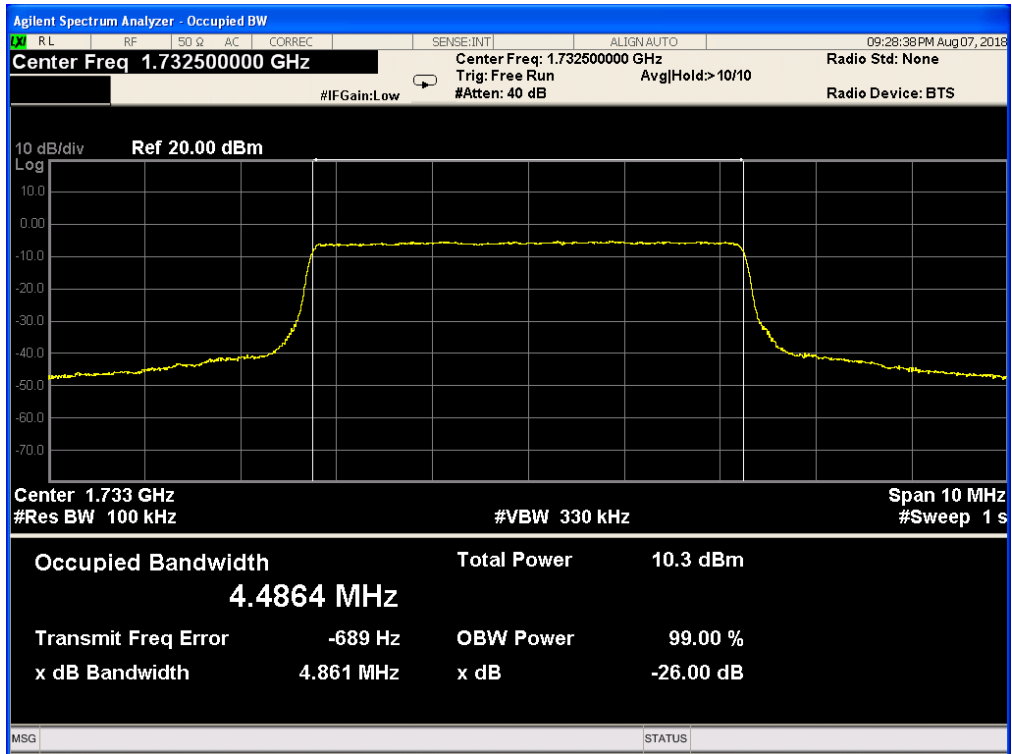

Band 4,UL Channel 20175,UL Frequency 1732.5,BW 5.0,NO. RB 25,RB POS. Low,16-QAM

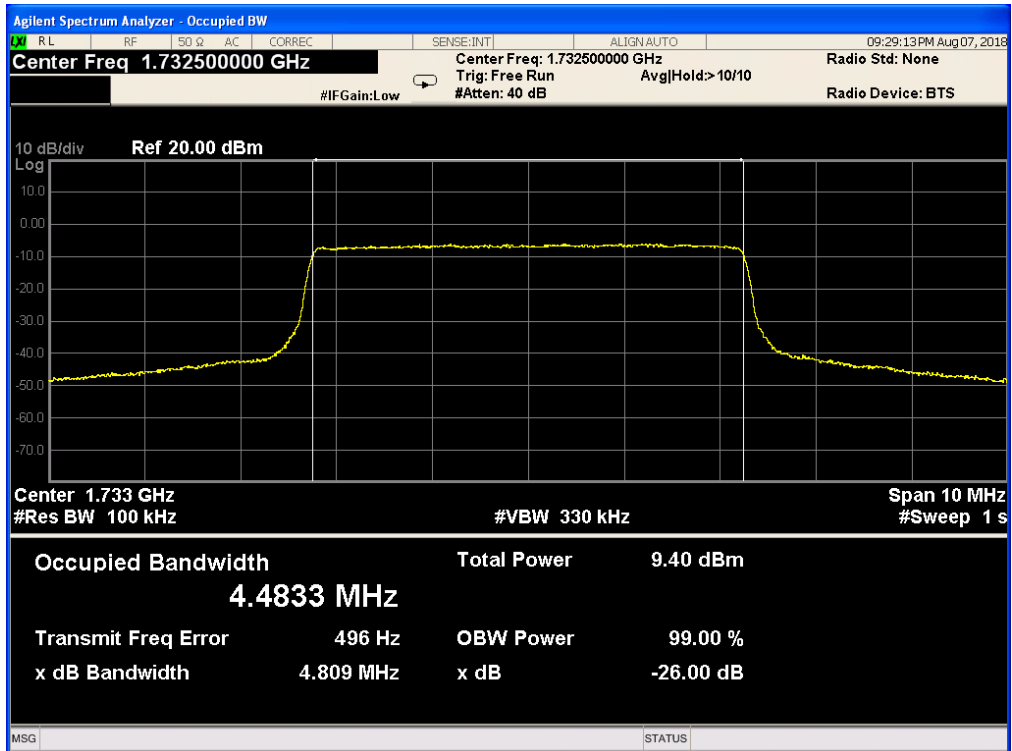



Band 4,UL Channel 20175,UL Frequency 1732.5,BW 10.0,NO. RB 50,RB POS. Low,QPSK

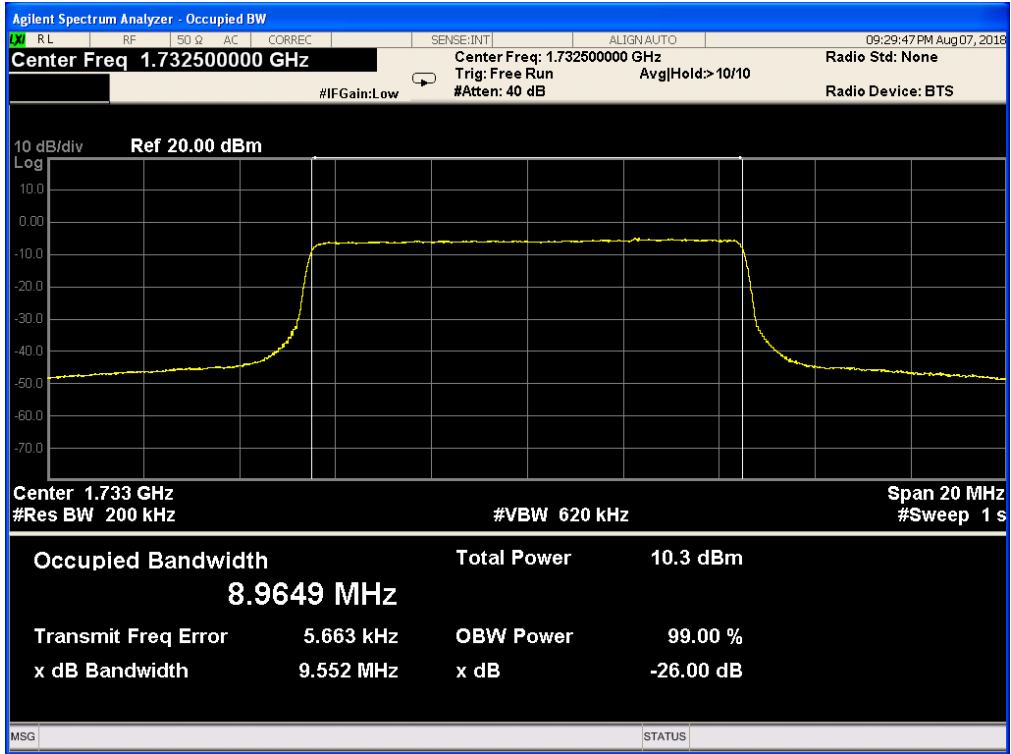

Band 4,UL Channel 20175,UL Frequency 1732.5,BW 10.0,NO. RB 50,RB POS. Low,16-QAM

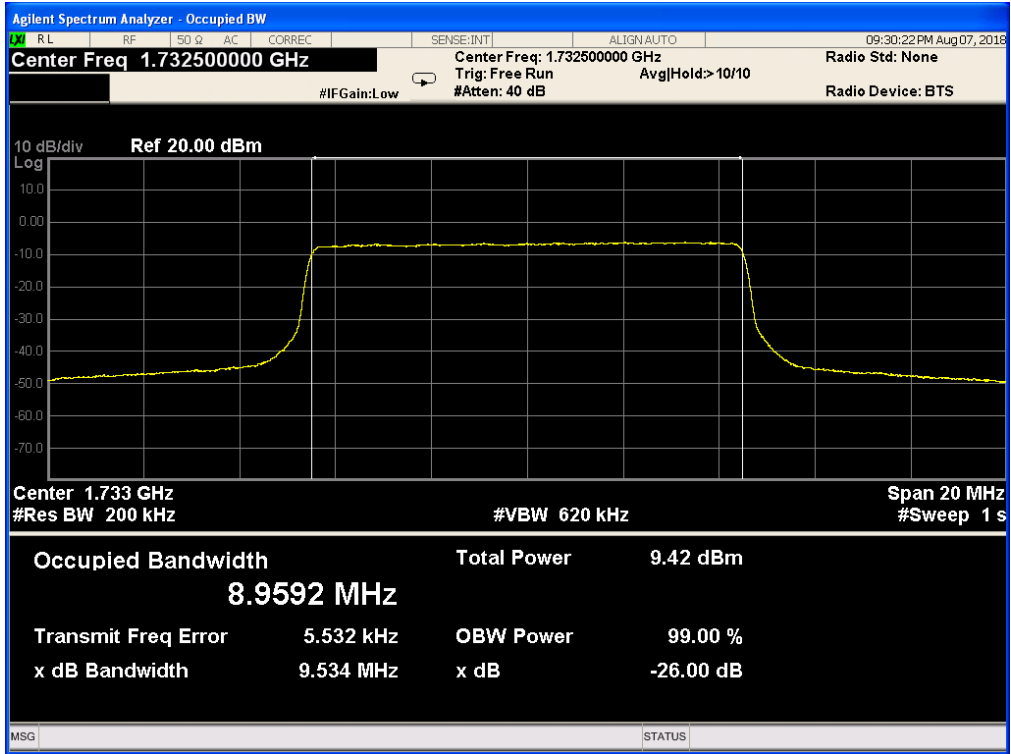



Band 4,UL Channel 20175,UL Frequency 1732.5,BW 15.0,NO. RB 75,RB POS. Low,QPSK

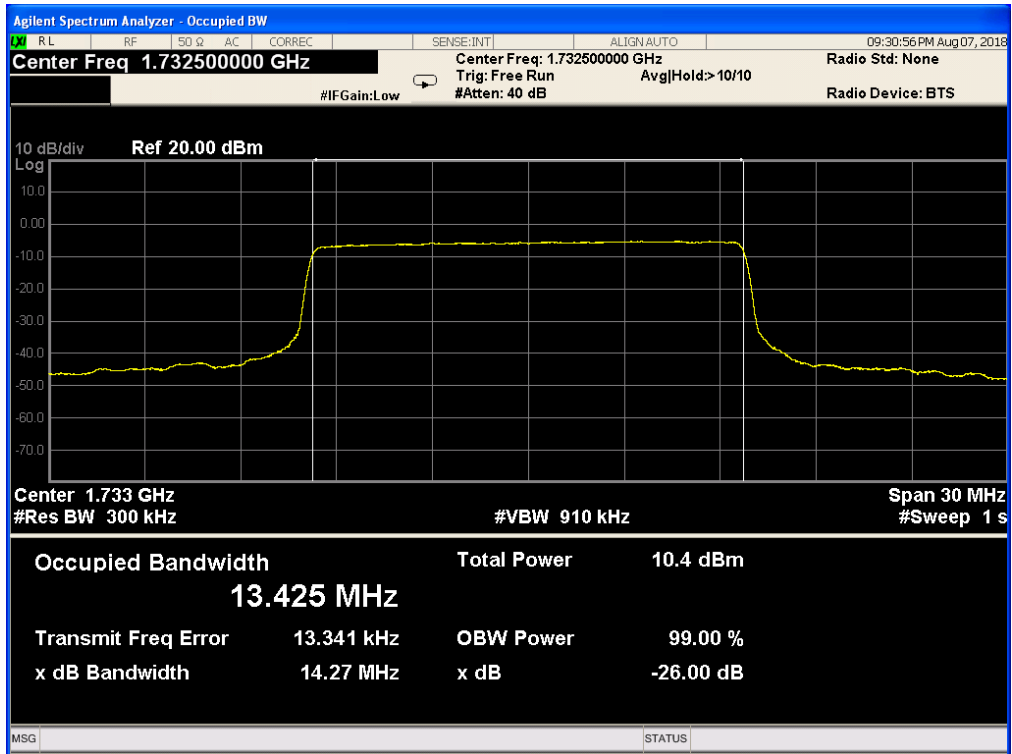

Band 4,UL Channel 20175,UL Frequency 1732.5,BW 15.0,NO. RB 75,RB POS. Low,16-QAM

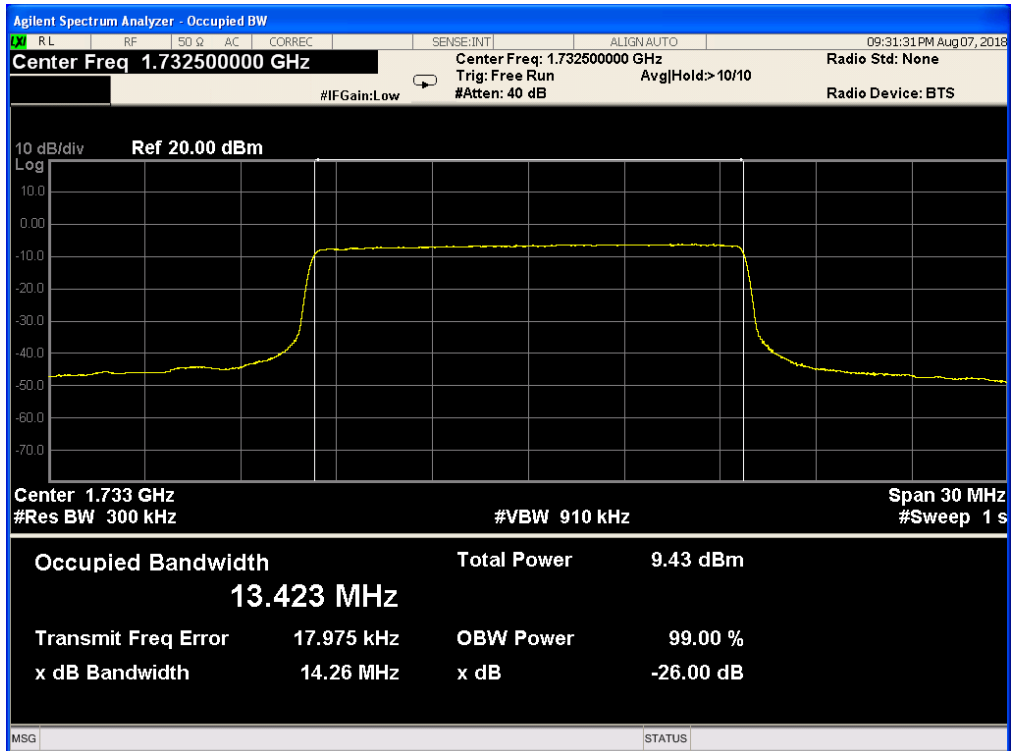





Band 4,UL Channel 20175,UL Frequency 1732.5,BW 20.0,NO. RB 100,RB POS. Low,QPSK

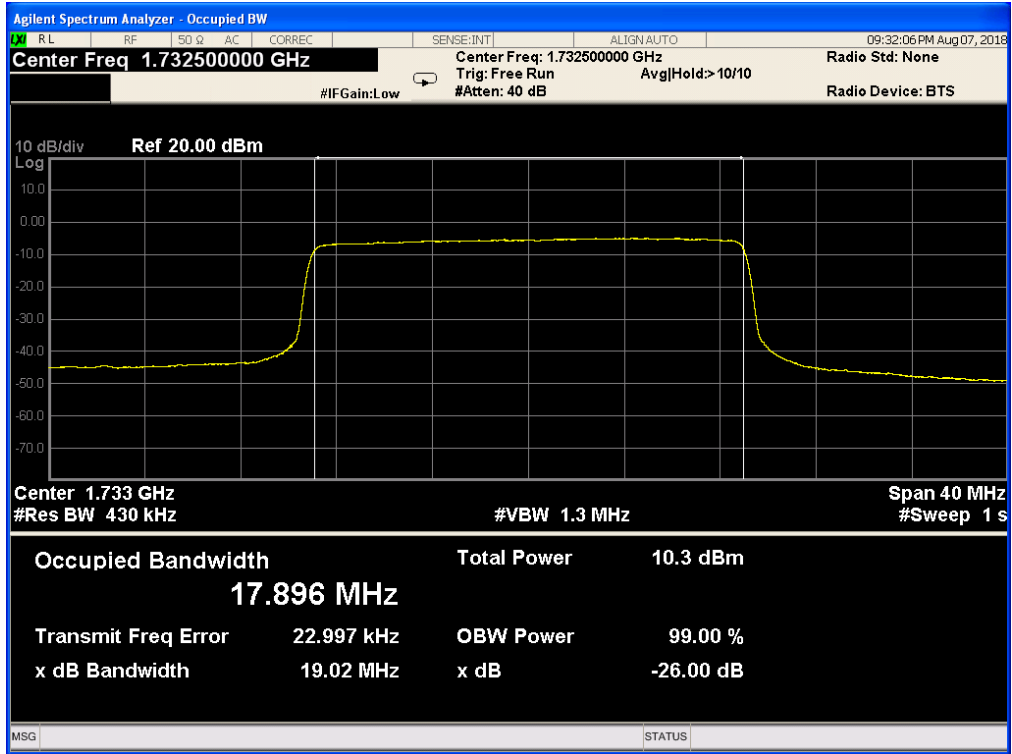

Band 4,UL Channel 20175,UL Frequency 1732.5,BW 20.0,NO. RB 100,RB POS. Low,16-QAM

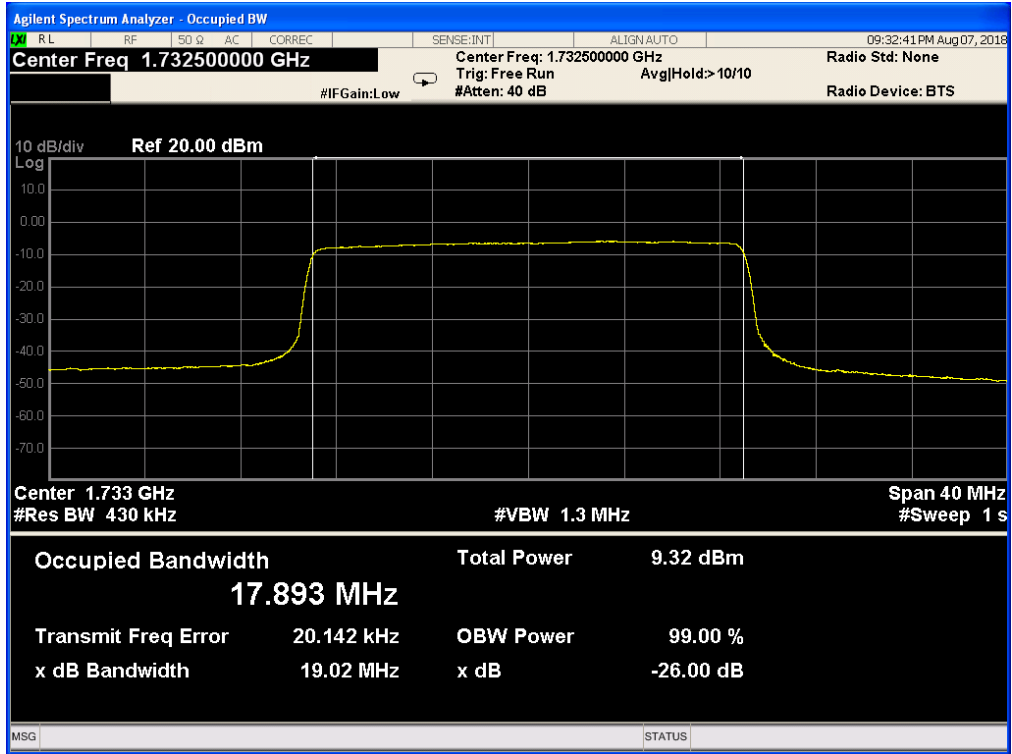



### 5.4 LTE BAND 13

Band 13,UL Channel 23230,UL Frequency 782.0,BW 5.0,NO. RB 25,RB POS. Low,QPSK

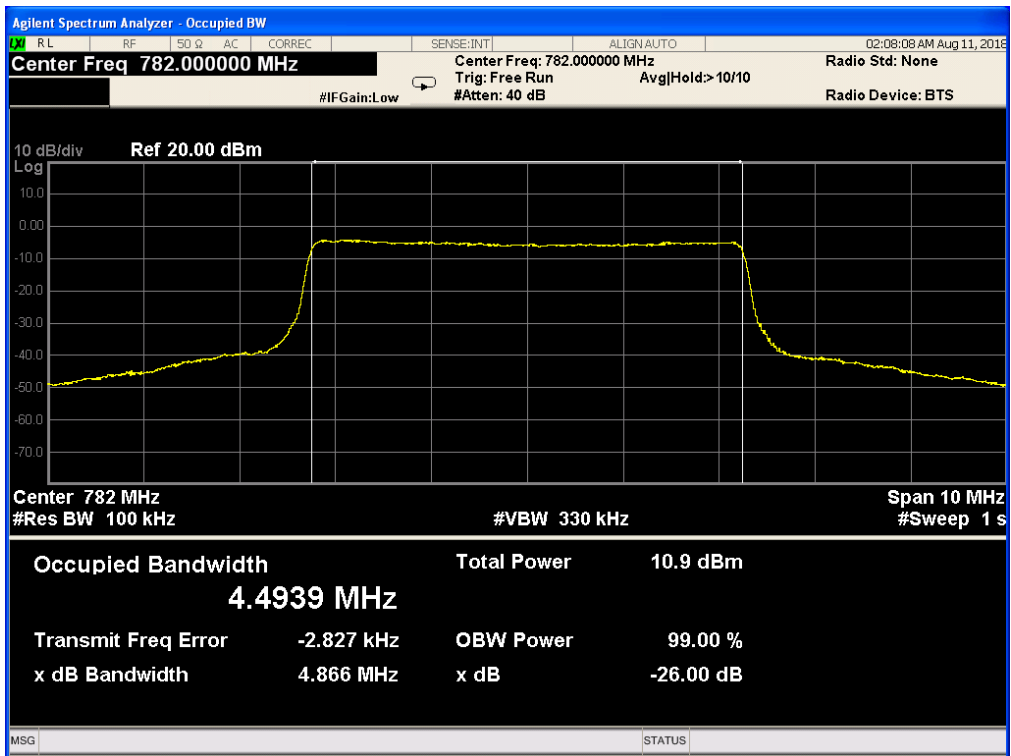

Band 13,UL Channel 23230,UL Frequency 782.0,BW 5.0,NO. RB 25,RB POS. Low,16-QAM

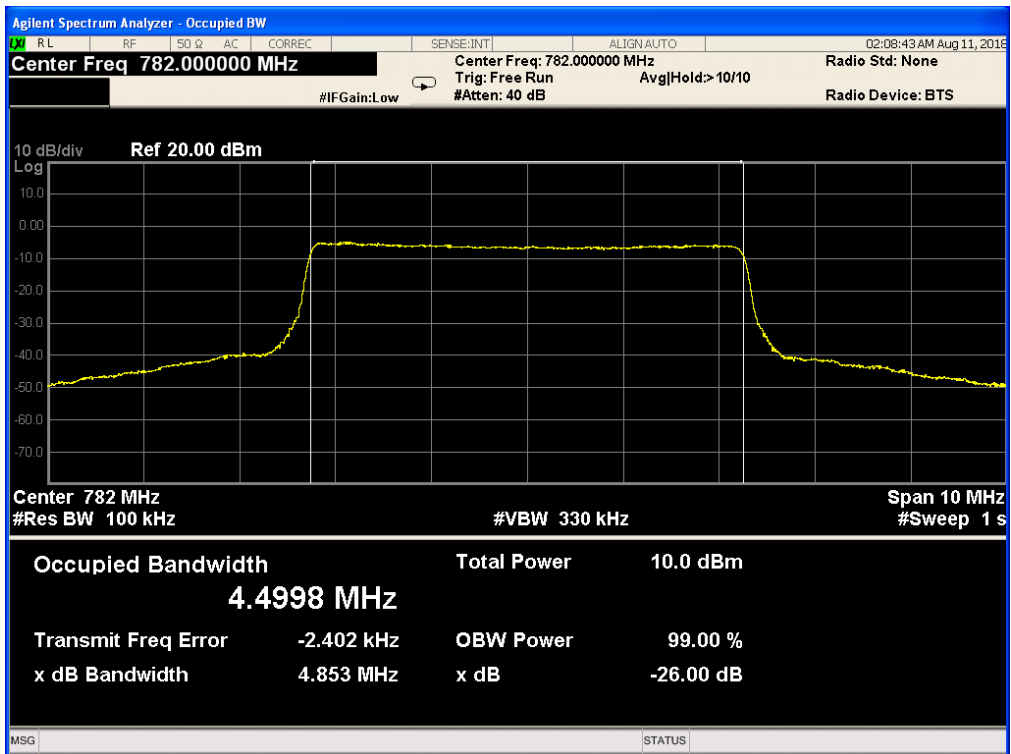



Band 13,UL Channel 23230,UL Frequency 782.0,BW 10.0,NO. RB 50,RB POS. Low,QPSK

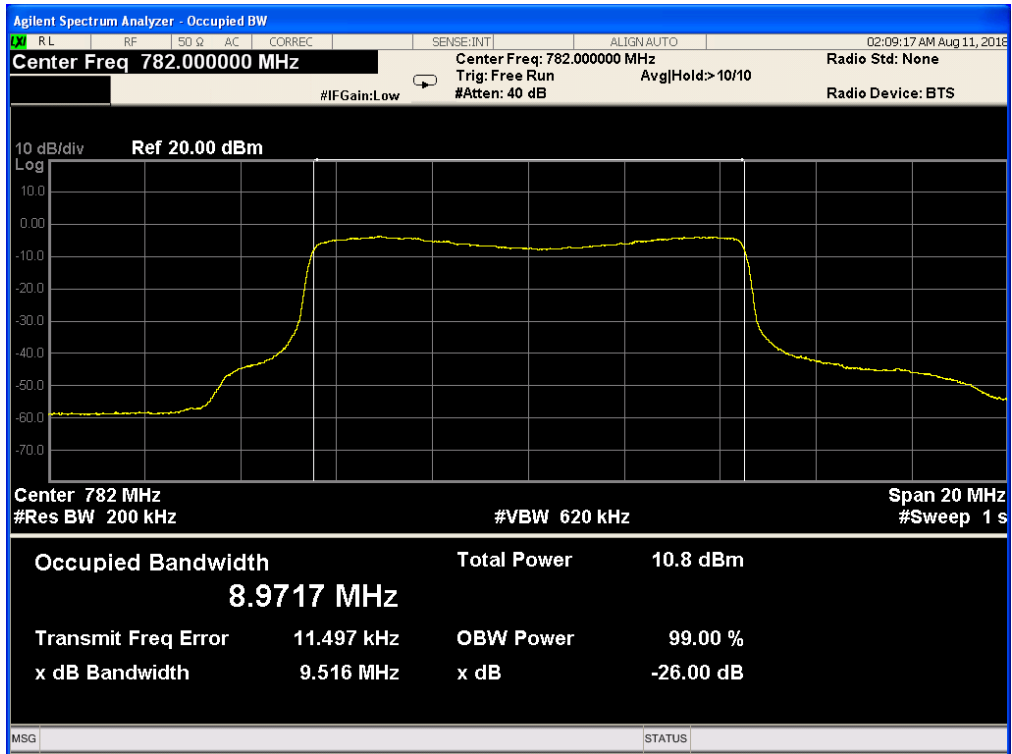

Band 13,UL Channel 23230,UL Frequency 782.0,BW 10.0,NO. RB 50,RB POS. Low,16-QAM

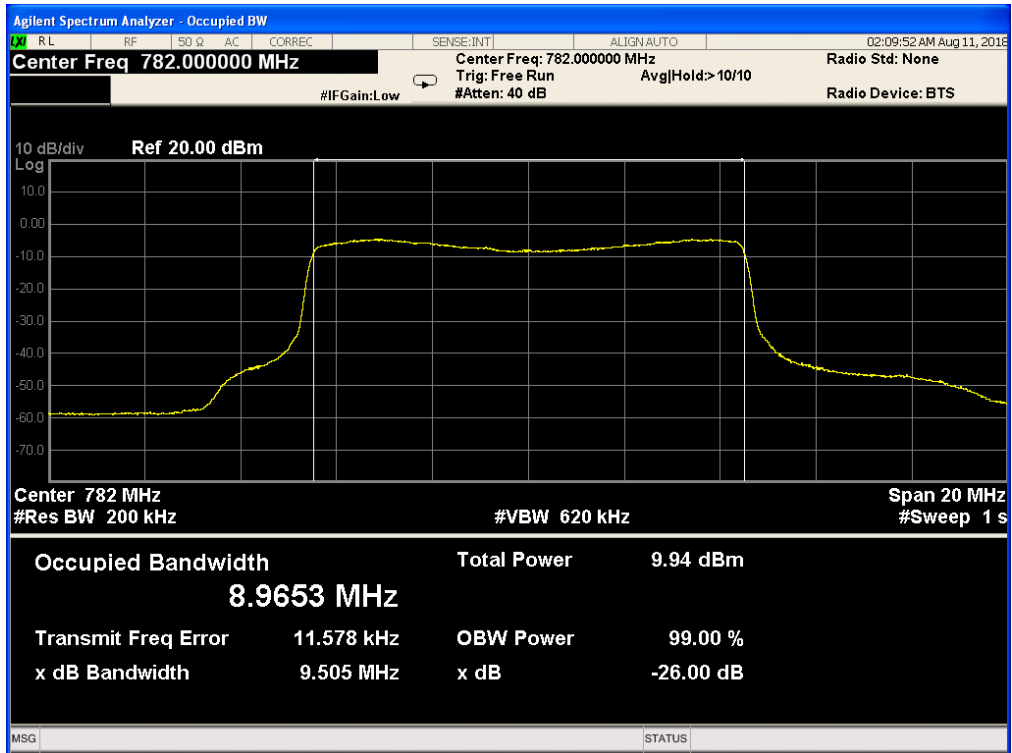



## 6. BANDEDGE AND EMISSION MASK

### RULE PART(S)

FCC: §2.1051, §22.901, §22.917, §24.238, §27.53, and §90.691

FCC: §22.359

### LIMITS

FCC: §22.359, §24.238,

The power of any emission outside of the authorized operating frequency ranges must be attenuated below the transmitting power (P) by a factor of at least  $43 + 10 \log (P)$  dB.

(m)(4) For mobile digital stations, the attenuation factor shall be not less than  $40 + 10 \log (P)$  dB on all frequencies between the channel edge and 5 megahertz from the channel edge,  $43 + 10 \log (P)$  dB on all frequencies between 5 megahertz and X megahertz from the channel edge, and  $55 + 10 \log (P)$  dB on all frequencies more than X megahertz from the channel edge, where X is the greater of 6 megahertz or the actual emission bandwidth as defined in paragraph (m)(6) of this section. In addition, the attenuation factor shall not be less than  $43 + 10 \log (P)$  dB on all frequencies between 2490.5 MHz and 2496 MHz and  $55 + 10 \log (P)$  dB at or below 2490.5 MHz. Mobile Satellite Service licensees operating on frequencies below 2495 MHz may also submit a documented interference complaint against BRS licensees operating on channel BRS Channel 1 on the same terms and conditions as adjacent channel BRS or EBS licensees. Show citation box.

### TEST PROCEDURE

The transmitter output was connected to a CMW500 Test Set and configured to operate at maximum power. The band edge emissions were measured at the required operating frequencies in each band on the Spectrum Analyzer.

For each band edge measurement:

Set the spectrum analyzer span to include the block edge frequency (704, 716, 824, 849, 1710 and 1755, 1850 and 1910MHz)

Set a marker to point the corresponding band edge frequency in each test case.

Set display line at -13 dBm

Set resolution bandwidth to at least 1% of emission bandwidth.

### MODES TESTED

- LTE Band 2
- LTE Band 4
- LTE Band 13

### RESULTS



### 6.1 LTE BAND 2

Band 2,UL Channel 18607,UL Frequency 1850.7,BW 1.4,NO. RB 6,RB POS. Low,QPSK

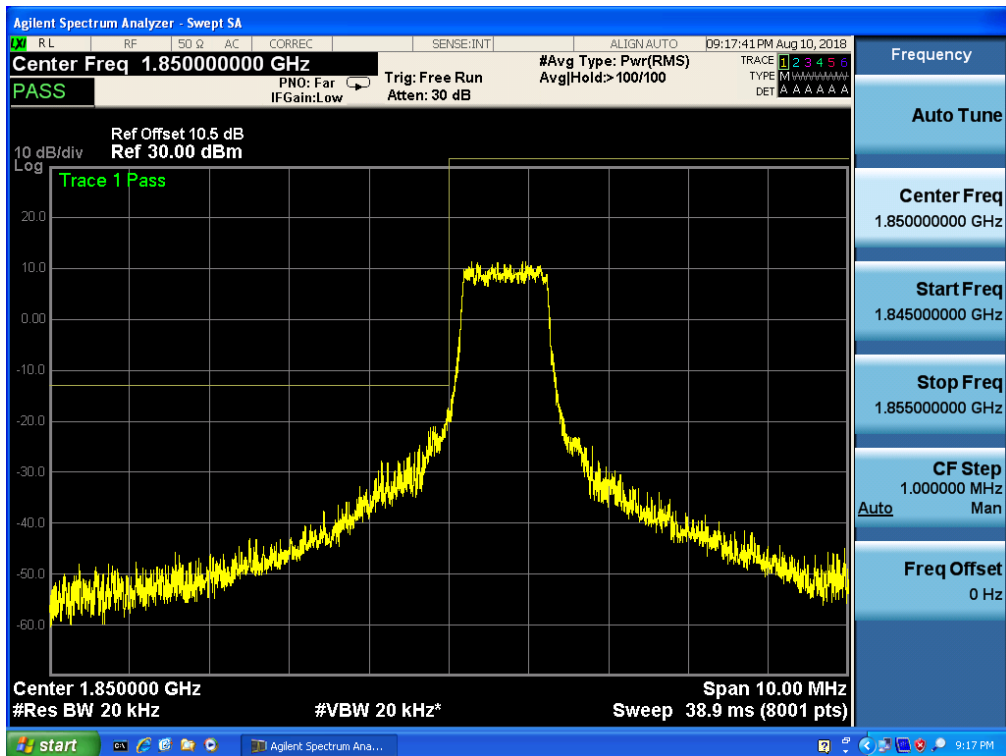

Band 2,UL Channel 18607,UL Frequency 1850.7,BW 1.4,NO. RB 6,RB POS. Low,QPSK

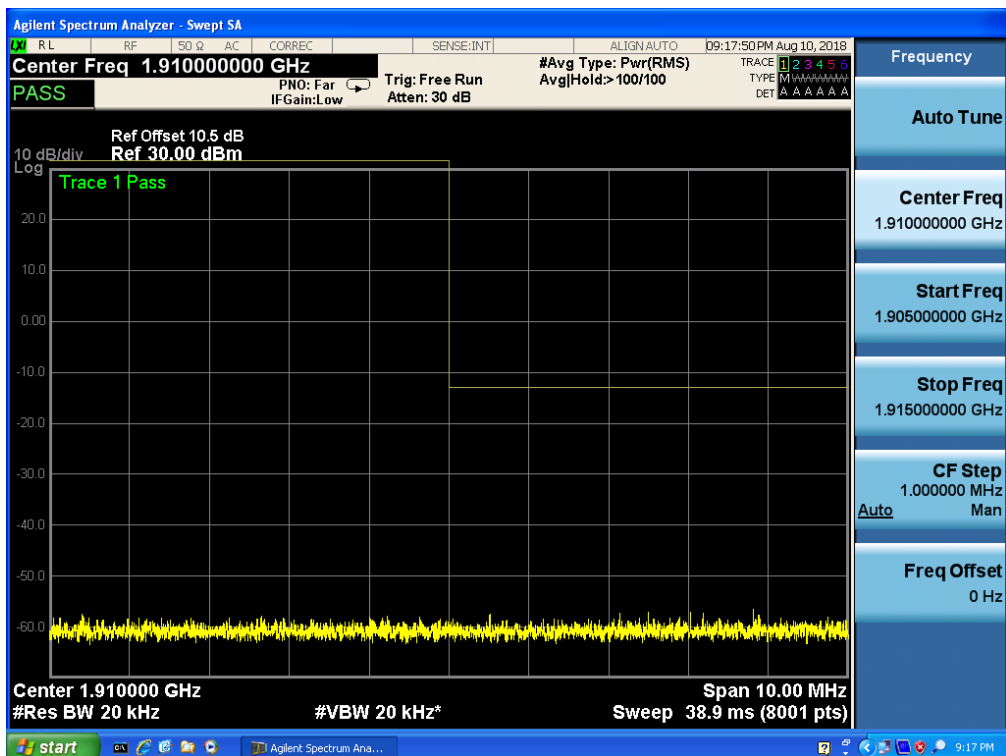



Report No.: SER180628704006E

Band 2,UL Channel 18607,UL Frequency 1850.7,BW 1.4,NO. RB 6,RB POS. Low,16QAM

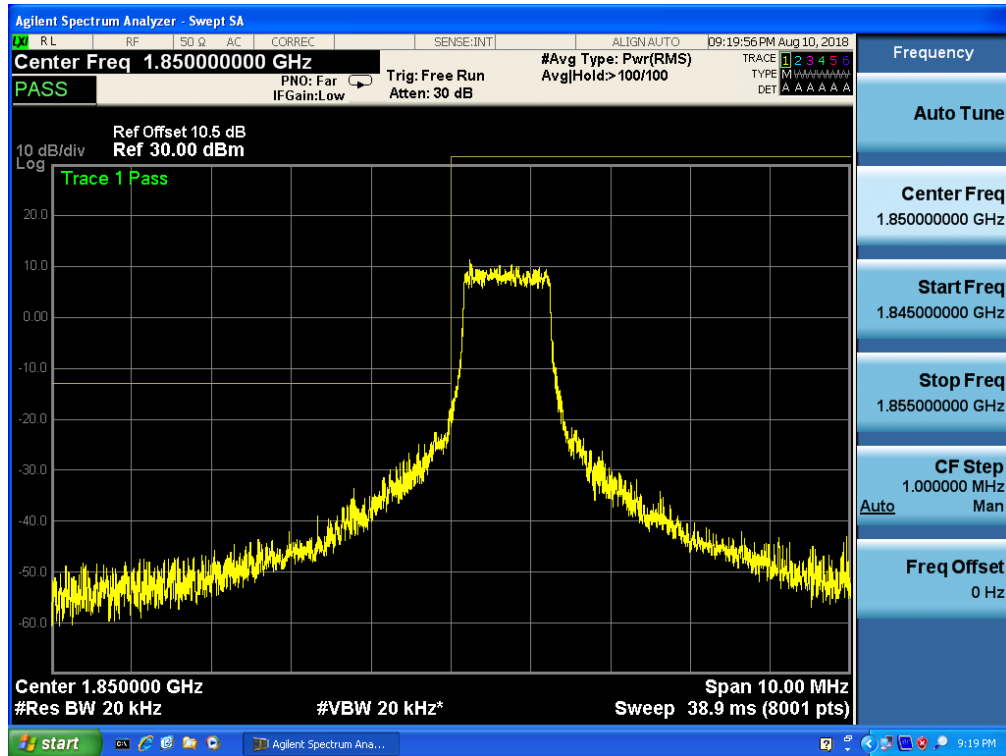

Band 2,UL Channel 18607,UL Frequency 1850.7,BW 1.4,NO. RB 6,RB POS. Low,16QAM

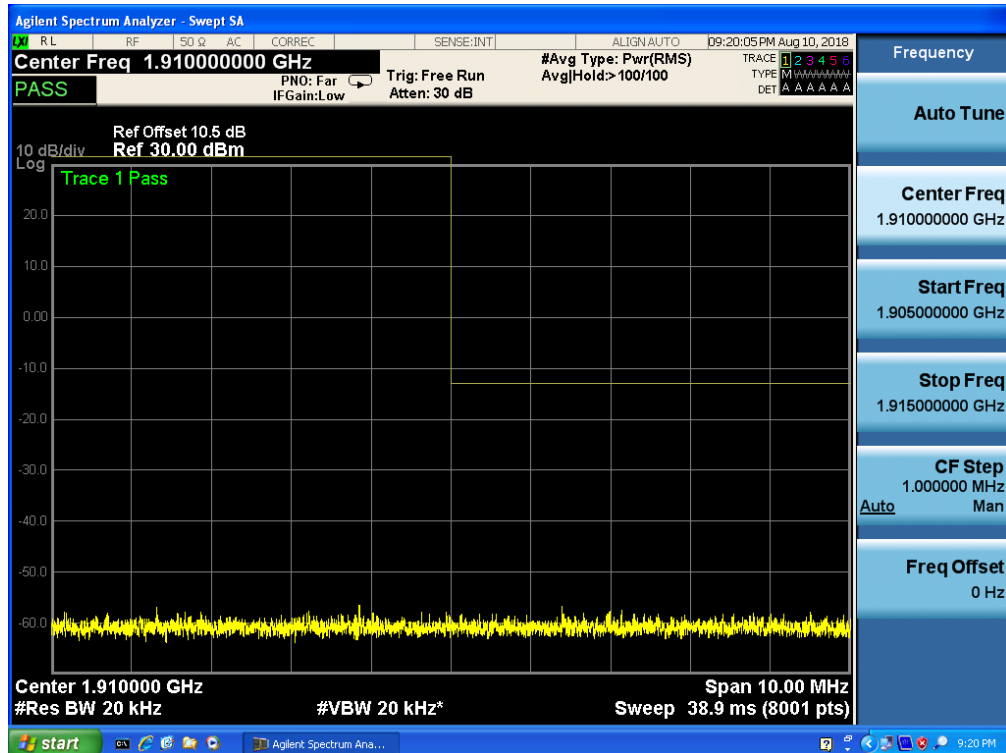



Band 2,UL Channel 19193,UL Frequency 1909.3,BW 1.4,NO. RB 6,RB POS. Low,QPSK

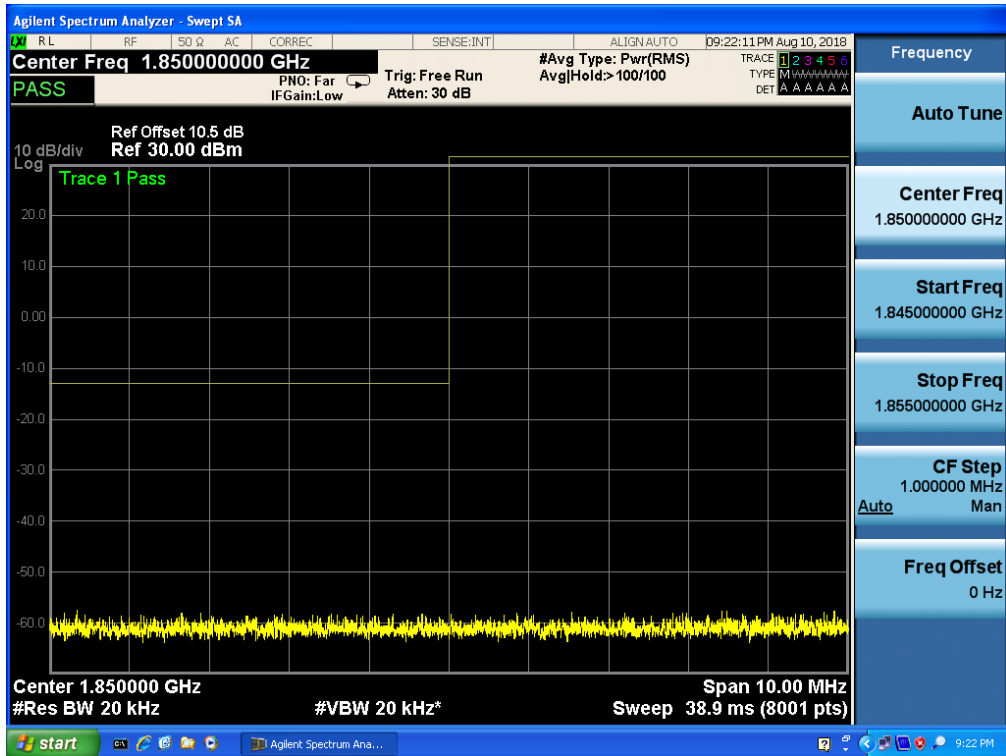

Band 2,UL Channel 19193,UL Frequency 1909.3,BW 1.4,NO. RB 6,RB POS. Low,QPSK

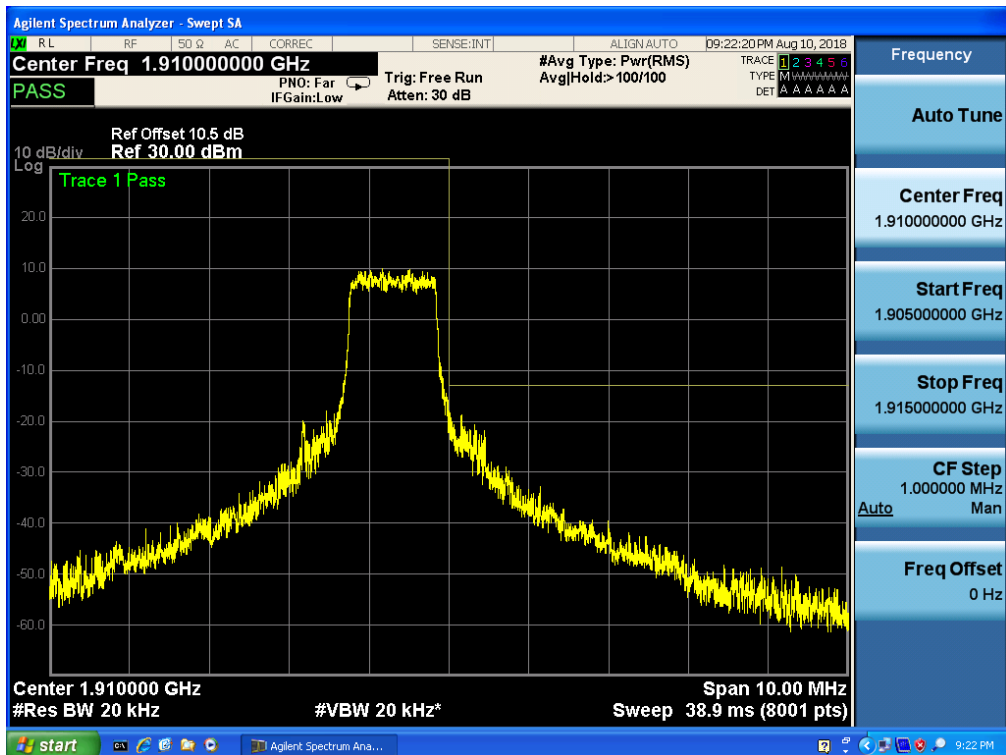



Band 2,UL Channel 19193,UL Frequency 1909.3,BW 1.4,NO. RB 6,RB POS. Low,16QAM

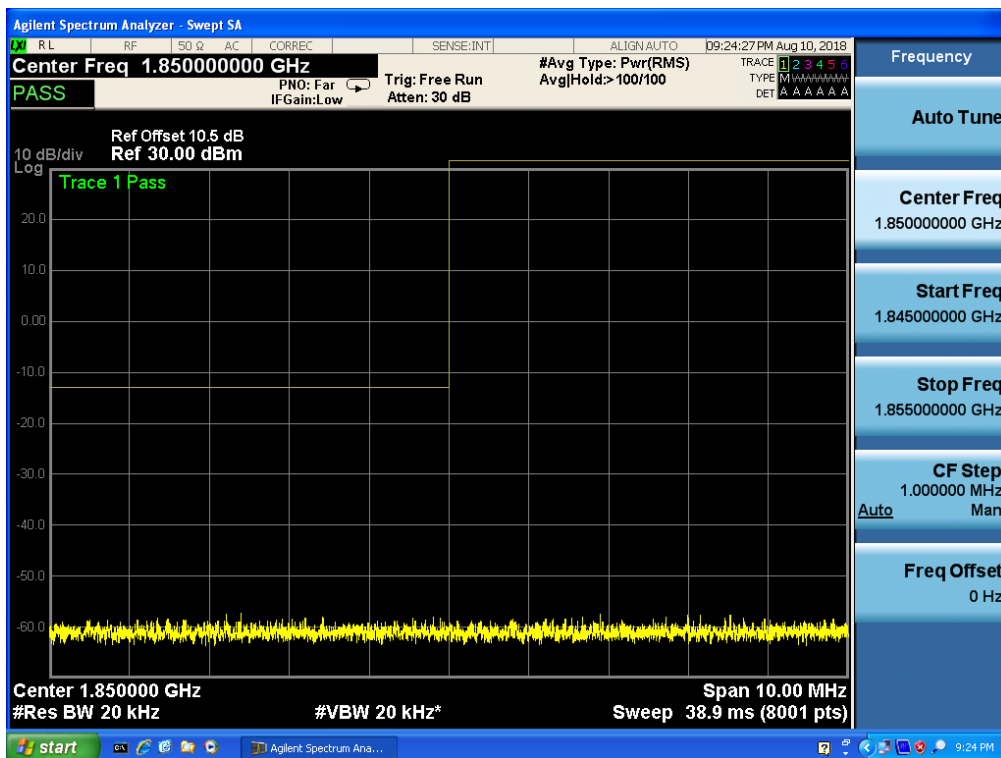

Band 2,UL Channel 19193,UL Frequency 1909.3,BW 1.4,NO. RB 6,RB POS. Low,16QAM

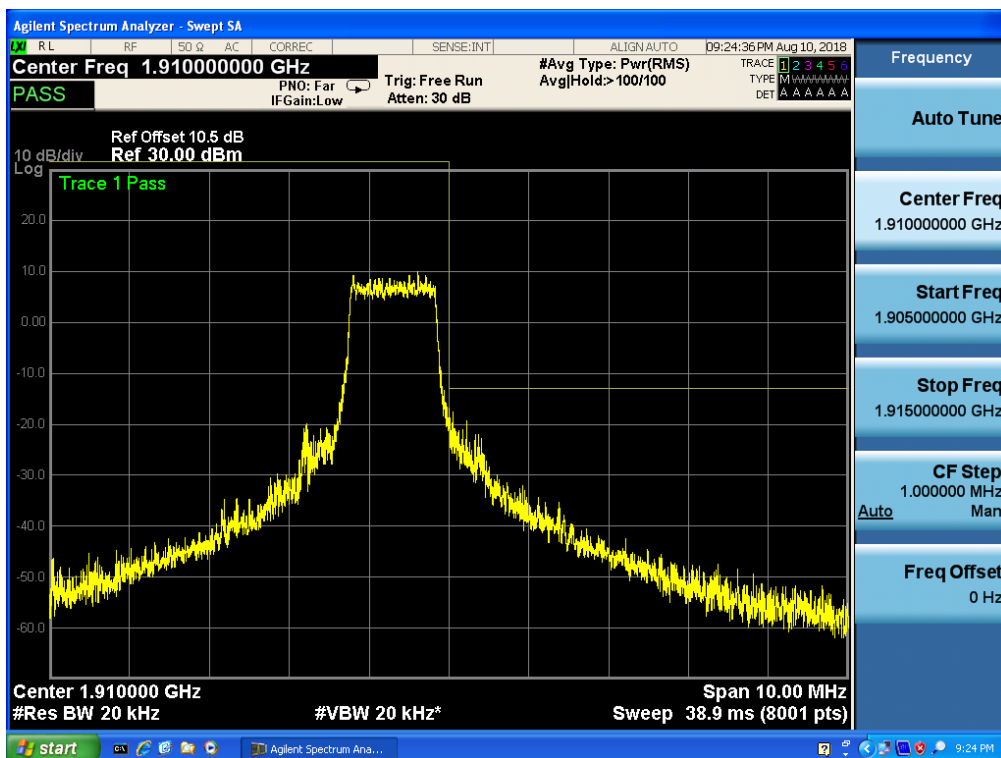





Band 2,UL Channel 18615,UL Frequency 1851.5,BW 3.0,NO. RB 15,RB POS. Low,QPSK

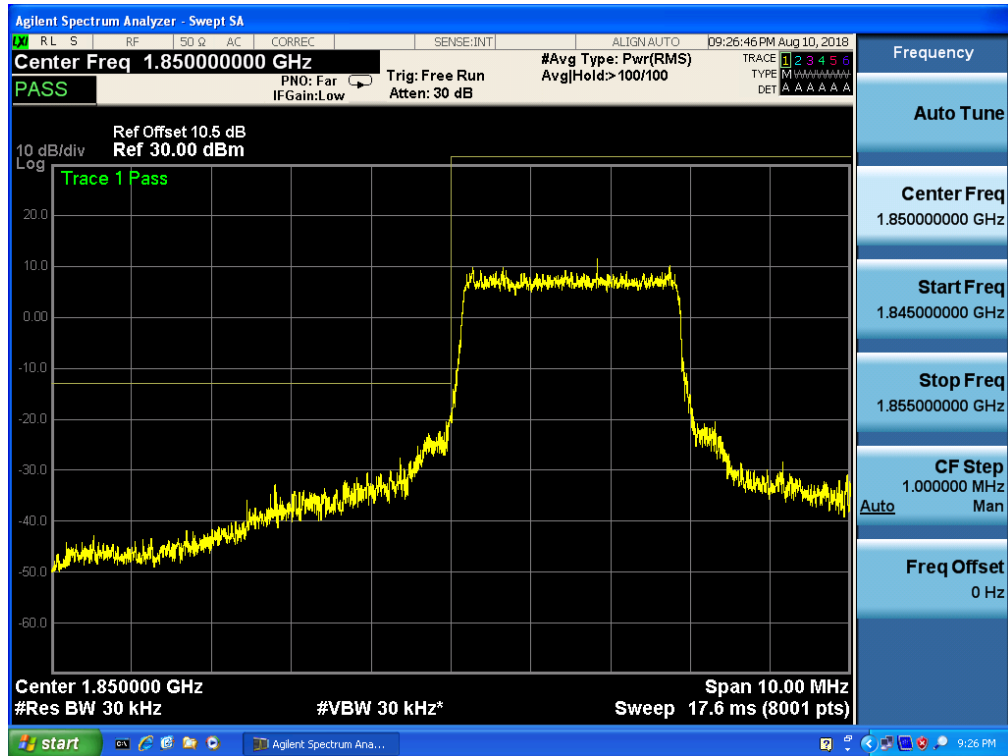

Band 2,UL Channel 18615,UL Frequency 1851.5,BW 3.0,NO. RB 15,RB POS. Low,QPSK

