

FCC Test Report

FCC ID: 2ACC5-GT50VH2

Product: Handheld Device
Trade Mark: N/A
Model Number: GT50VH2
Serial Model: N/A
Report No.: SER180628704007E

Prepared for

AMobile Intelligent Corp.
8F.-1, No.700, Zhongzheng Rd., Zhonghe Dist New Taipei City,
235 Taiwan

Prepared by

Shenzhen NTEK Testing Technology Co., Ltd.
1/F, Building E, Fenda Science Park, Sanwei Community,
Xixiang Street Bao'an District, Shenzhen P.R. China
Tel.: +86-755-6115 6588
Fax.: +86-755-6115 6599
Website:<http://www.ntek.org.cn>



Certificate #4298.01

Report No.: SER180628704007E

TEST RESULT CERTIFICATION

Applicant's name: AMobile Intelligent Corp.
Address: 8F.-1, No.700, Zhongzheng Rd., Zhonghe Dist New Taipei City, 235
Taiwan

Manufacturer's Name.....: AMobile Intelligent Corp.
Address: 8F.-1, No.700, Zhongzheng Rd., Zhonghe Dist New Taipei City, 235
Taiwan

Product description

Product name.....: Handheld Device

Model and/or type reference : GT50VH2

FCC Part15B

Standards.....: ANSI C63.4:2014

This device described above has been tested by NTEK, and the test results show that the equipment under test (EUT) is in compliance with Part 15 of FCC Rules. And it is applicable only to the tested sample identified in the report.

This report shall not be reproduced except in full, without the written approval of NTEK, this document may be altered or revised by NTEK, personnel only, and shall be noted in the revision of the document.

Date of Test

Date (s) of performance of tests: 28 Jun. 2018 ~ 24 Aug. 2018

Date of Issue.....: 27 Aug. 2018

Test Result.....: **Pass**

Testing Engineer : Loren Luo
(Loren Luo)

Technical Manager : Jason Chen
(Jason Chen)

Authorized Signatory : Sam Chen
(Sam Chen)

Table of Contents

Page

1 . TEST SUMMARY	4
1.1 TEST FACILITY	5
1.2 MEASUREMENT UNCERTAINTY	5
2 . GENERAL INFORMATION	6
2.1 GENERAL DESCRIPTION OF EUT	6
2.2 DESCRIPTION OF TEST SETUP	8
2.3 DESCRIPTION TEST PERIPHERAL AND EUT PERIPHERAL	9
2.4 MEASUREMENT INSTRUMENTS LIST	10
3 . EMC EMISSION TEST	11
3.1 CONDUCTED EMISSION MEASUREMENT	11
3.1.1 POWER LINE CONDUCTED EMISSION	11
3.1.2 TEST PROCEDURE	12
3.1.3 TEST SETUP	12
3.1.4 EUT OPERATING CONDITIONS	12
3.1.5 TEST RESULTS	13
3.2 RADIATED EMISSION MEASUREMENT	17
3.2.1 LIMITS OF RADIATED EMISSION MEASUREMENT	17
3.2.2 TEST PROCEDURE	17
3.2.3 TEST SETUP	18
3.2.4 TEST RESULTS	19
3.2.5 TEST RESULTS(1000~6000MHz)	21

1. TEST SUMMARY

Test procedures according to the technical standards:

EMC Emission				
Standard	Test Item	Limit	Judgment	Remark
FCC Part15B ANSI C63.4: 2014	Conducted Emission	Class B	PASS	
	Radiated Emission	Class B	PASS	

NOTE:

- (1) 'N/A' denotes test is not applicable in this Test Report
- (2) For client's request and manual description, the test will not be executed.

1.1 TEST FACILITY

Shenzhen NTEK Testing Technology Co., Ltd
 Add. : 1/F, Building E, Fenda Science Park, Sanwei Community, Xixiang Street, Bao'an District, Shenzhen 518126 P.R. China.
 FCC Registration Number:463705; IC Registration Number:9270A-1
 CNAS Registration Number:L5516

1.2 MEASUREMENT UNCERTAINTY

The reported uncertainty of measurement $y \pm U$, where expanded uncertainty U is based on a standard uncertainty multiplied by a coverage factor of $k=2$, providing a level of confidence of approximately **95** %.

A. Conducted Measurement :

Test Site	Method	Measurement Frequency Range	U, (dB)	NOTE
NTEKC01	ANSI	150 KHz ~ 30MHz	3.2	

B. Radiated Measurement :

Test Site	Method	Measurement Frequency Range	U, (dB)	NOTE
NTEKA01	ANSI	30MHz ~ 1000MHz	4.7	
		1GHz ~12.4GHz	5.0	

2. GENERAL INFORMATION

2.1 GENERAL DESCRIPTION OF EUT

Equipment	Handheld Device	
Trade Mark	N/A	
Model Name	GT50VH2	
Serial Model	N/A	
Model Difference	N/A	
Product Description	The EUT is a Handheld Device.	
	Connecting I/O port:	USB, earphone
	Operation Frequency:	1.3GHz
Based on the application, features, or specification exhibited in User's Manual, the EUT is considered as an multimedia Device. More details of EUT technical specification, please refer to the User's Manual.		
Power Source	DC 3.8V from battery or DC 5V from USB port	
Adapter	Model:PSAF10R-050Q Input: 100-240V~50-60Hz 0.3A Output: 5V ---2.0A	
Battery	DC 3.8V, 5200mAh	
HW Version	GT-500V_MB_V1.1_170929	
SW Version	V018.08.01	

2.1.1 DESCRIPTION OF TEST MODES

To investigate the maximum EMI emission characteristics generates from EUT, the test system was pre-scanning tested base on the consideration of following EUT operation mode or test configuration mode which possible have effect on EMI emission level. Each of these EUT operation mode(s) or test configuration mode(s) mentioned above was evaluated respectively.

Pretest Mode	Description
Mode 1	Connect to PC
Mode 2	TF card Play
Mode 3	REC
Mode 4	FM RX

For Conducted Test	
Final Test Mode	Description
Mode 1	Connect to PC
Mode 2	TF card Play
Mode 3	REC
Mode 4	FM RX

For Radiated Test	
Final Test Mode	Description
Mode 1	Connect to PC
Mode 2	TF card Play
Mode 3	REC
Mode 4	FM RX

Note: Final Test Mode: Through Pre-scan, find the mode 1 is the worst case. Only the worst case mode is recorded in the report.

2.2 DESCRIPTION OF TEST SETUP

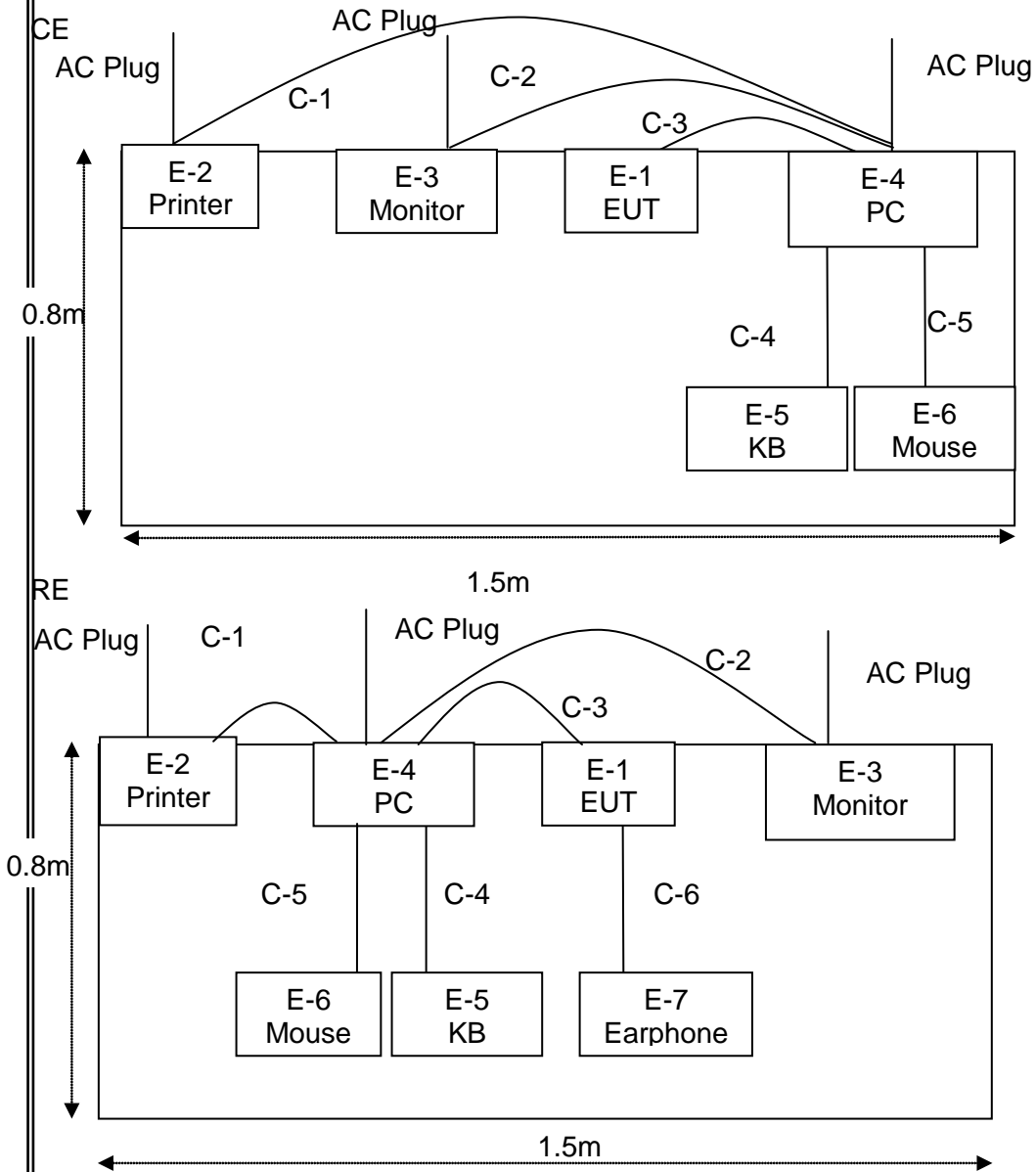

2.3 DESCRIPTION TEST PERIPHERAL AND EUT PERIPHERAL

The EUT has been tested as an independent unit together with other necessary accessories or support units. The following support units or accessories were used to form a representative test configuration during the tests.

Item	Equipment	Brand	Model/Type No.	Series No.	Note
E-1	Handheld Device	N/A	GT50VH2	N/A	EUT
E-2	Printer	Canon	L11121E	N/A	Peripherals
E-3	Monitor	SHARP	LCD-32MS46A	N/A	Peripherals
E-4	Personal computer	DELL	FT4Y23X	N/A	Peripherals
E-5	KB	DELL	SK-8185	N/A	Peripherals
E-6	Mouse	DELL	MS111-P	N/A	Peripherals
E-7	Earphone	N/A	N/A	N/A	Peripherals

Item	Cable Type	Shielded Type	Ferrite Core	Length	Note
C-1	USB Cable	NO	NO	1.0m	
C-2	HDMI Cable	NO	NO	1.0m	
C-3	USB Cable	NO	NO	1.0m	
C-4	KB Cable	NO	NO	1.2m	
C-5	Mouse Cable	NO	NO	1.2m	
C-6	Earphone Cable	NO	NO	1.0m	

Note:

- (1) The support equipment was authorized by Declaration of Confirmation.
- (2) For detachable type I/O cable should be specified the length in cm in 『Length』 column.
- (3) “YES” means “shielded” “with core”; “NO” means “unshielded” “without core”.

2.4 MEASUREMENT INSTRUMENTS LIST

Radiation Test equipment

Item	Kind of Equipment	Manufacturer	Type No.	Serial No.	Last calibration	Calibrated until	Calibration period
1	Spectrum Analyzer	Agilent	E4407B	MY45108040	2018.05.19	2019.05.18	1 year
2	Test Receiver	R&S	ESPI	101318	2018.05.19	2019.05.18	1 year
3	Bilog Antenna	TESEQ	CBL6111D	31216	2018.04.09	2019.04.08	1 year
4	50Ω Coaxial Switch	Anritsu	MP59B	6200264416	2018.05.19	2019.05.18	1 year
5	Spectrum Analyzer	ADVANTEST	R3132	150900201	2018.05.19	2019.05.18	1 year
6	Horn Antenna	EM	EM-AH-10180	2011071402	2018.04.09	2019.04.08	1 year
7	Horn Ant	Schwarzbeck	BBHA 9170	9170-181	2018.05.19	2019.05.18	1 year
8	Amplifier	EMC	EMC051835SE	980246	2018.08.05	2019.08.04	1 year
9	Loop Antenna	ARA	PLA-1030/B	1029	2018.05.19	2019.05.18	1 year
10	Power Sensor	R&S	URV5-Z4	0395.1619.05	2018.05.19	2019.05.18	1 year
11	Test Cable (30MHz-1GHz)	N/A	R-02	N/A	2017.04.21	2020.04.20	3 year
12	High Test Cable(1G-40 GHz)	N/A	R-03	N/A	2017.04.21	2020.04.20	3 year
13	High Test Cable(1G-40 GHz)	N/A	R-04	N/A	2017.04.21	2020.04.20	3 year

AC Conduction Test equipment

Item	Kind of Equipment	Manufacturer	Type No.	Serial No.	Last calibration	Calibrated until	Calibration period
1	Test Receiver	R&S	ESCI	101160	2018.05.19	2019.05.18	1 year
2	LISN	R&S	ENV216	101313	2018.04.19	2019.04.18	1 year
3	LISN	SCHWARZBECK	NNLK 8129	8129245	2018.05.19	2019.05.18	1 year
4	50Ω Coaxial Switch	ANRITSU CORP	MP59B	6200983704	2018.05.19	2019.05.18	1 year
5	Test Cable (9KHz-30MHz)	N/A	C01	N/A	2017.04.21	2020.04.20	3 year
6	Test Cable (9KHz-30MHz)	N/A	C02	N/A	2017.04.21	2020.04.20	3 year
7	Test Cable (9KHz-30MHz)	N/A	C03	N/A	2017.04.21	2020.04.20	3 year

Note: Each piece of equipment is scheduled for calibration once a year except the Test Cable which is scheduled for calibration every 3 years.

3. EMC EMISSION TEST

3.1 CONDUCTED EMISSION MEASUREMENT

3.1.1 POWER LINE CONDUCTED EMISSION (Frequency Range 150KHz-30MHz)

FREQUENCY (MHz)	Class A (dBuV)		Class B (dBuV)	
	Quasi-peak	Average	Quasi-peak	Average
0.15 -0.5	79.00	66.00	66 - 56 *	56 - 46 *
0.50 -5.0	73.00	60.00	56.00	46.00
5.0 -30.0	73.00	60.00	60.00	50.00

Note:

- (1) The tighter limit applies at the band edges.
- (2) The limit of " * " marked band means the limitation decreases linearly with the logarithm of the frequency in the range.

The following table is the setting of the receiver

Receiver Parameters	Setting
Attenuation	10 dB
Start Frequency	0.15 MHz
Stop Frequency	30 MHz
IF Bandwidth	9 kHz

3.1.2 TEST PROCEDURE

- a. The EUT was placed 0.8 meters from the horizontal ground plane with EUT being connected to the power mains through a line impedance stabilization network (LISN). All other support equipments powered from additional LISN(s). The LISN provide 50 Ohm/ 50uH of coupling impedance for the measuring instrument.
- b. Interconnecting cables that hang closer than 40 cm to the ground plane shall be folded back and forth in the center forming a bundle 30 to 40 cm long.
- c. I/O cables that are not connected to a peripheral shall be bundled in the center. The end of the cable may be terminated, if required, using the correct terminating impedance. The overall length shall not exceed 1 m.
- d. LISN at least 80 cm from nearest part of EUT chassis.
- e. For the actual test configuration, please refer to the related Item –EUT Test Photos.

3.1.3 TEST SETUP

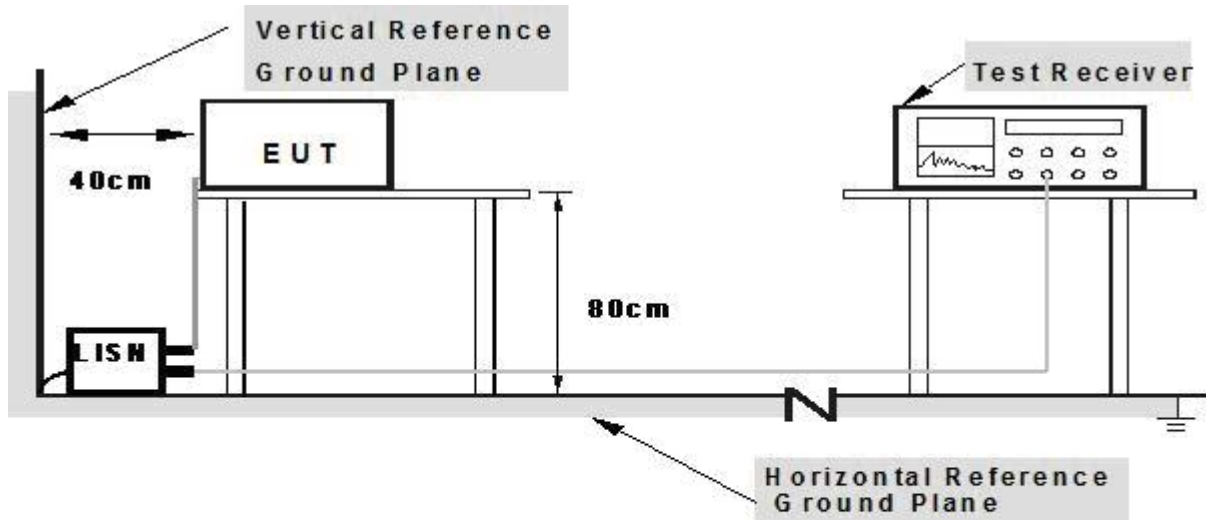

**Note: 1. Support units were connected to second LISN.
 2. Both of LISNs (AMN) are 80 cm from EUT and at least 80 from other units and other metal planes**

3.1.4 EUT OPERATING CONDITIONS

The EUT tested system was configured as the statements of 2.3 Unless otherwise a special operating condition is specified in the follows during the testing.

3.1.5 TEST RESULTS

EUT:	Handheld Device	Model Name. :	GT50VH2
Temperature:	26 °C	Relative Humidity:	54%
Pressure:	1010hPa	Test Date:	2018-7-10
Test Mode:	Mode 1	Phase :	L
Test Voltage:	DC 5V from PC AC120V/60Hz		

Frequency (MHz)	Reading Level (dBμV)	Correct Factor (dB)	Measure-ment (dBμV)	Limits (dBμV)	Margin (dB)	Remark
0.1620	42.84	9.76	52.60	65.36	-12.76	QP
0.1620	26.96	9.76	36.72	55.36	-18.64	AVG
0.5938	35.98	9.74	45.72	56.00	-10.28	QP
0.5938	25.18	9.74	34.92	46.00	-11.08	AVG
0.6500	26.45	9.74	36.19	46.00	-9.81	AVG
0.6540	38.43	9.74	48.17	56.00	-7.83	QP
1.0780	35.79	9.74	45.53	56.00	-10.47	QP
1.1298	20.12	9.74	29.86	46.00	-16.14	AVG
1.3619	38.97	9.75	48.72	56.00	-7.28	QP
1.3619	22.98	9.75	32.73	46.00	-13.27	AVG
13.4458	40.95	10.07	51.02	60.00	-8.98	QP
13.5617	30.34	10.07	40.41	50.00	-9.59	AVG

Remark:

1. All readings are Quasi-Peak and Average values.
2. Factor = Insertion Loss + Cable Loss.

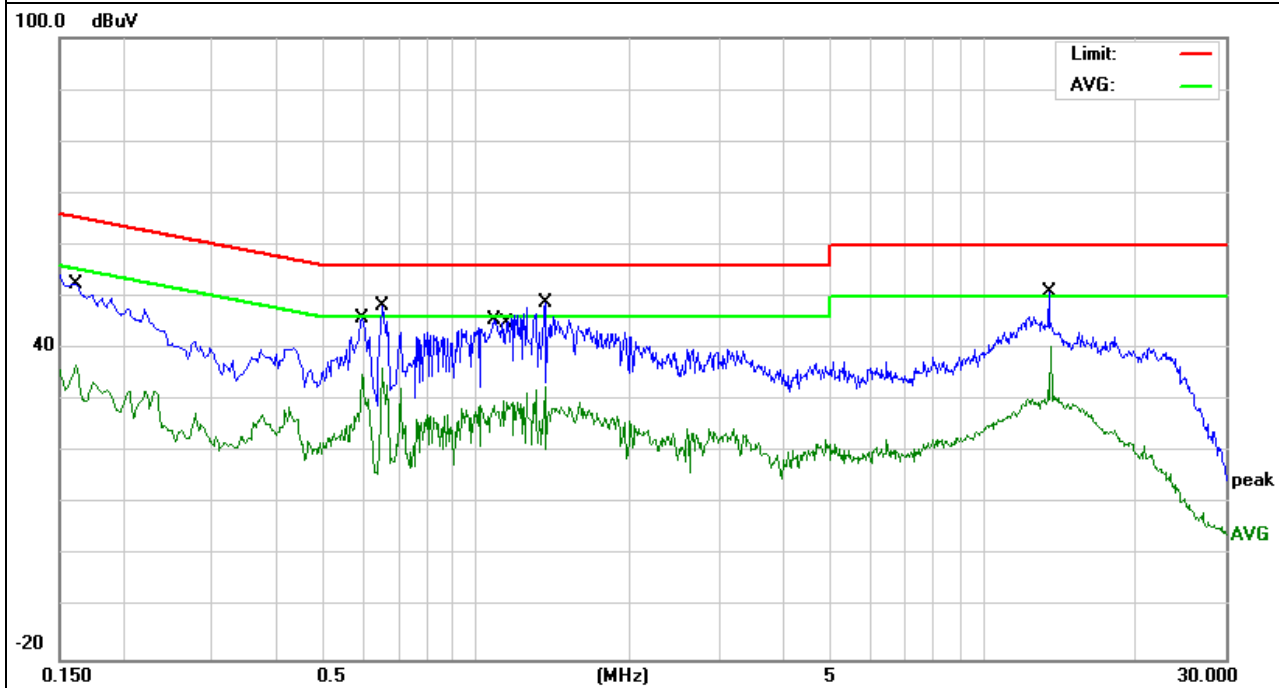

EUT:	Handheld Device	Model Name. :	GT50VH2
Temperature:	26 °C	Relative Humidity:	54%
Pressure:	1010hPa	Test Date:	2018-7-10
Test Mode:	Mode 1	Phase :	N
Test Voltage:	DC 5V from PC AC120V/60Hz		

Frequency (MHz)	Reading Level (dBμV)	Correct Factor (dB)	Measure-ment (dBμV)	Limits (dBμV)	Margin (dB)	Remark
0.1620	46.56	9.76	56.32	65.36	-9.04	QP
0.1620	28.91	9.76	38.67	55.36	-16.69	AVG
0.1980	43.01	9.76	52.77	63.69	-10.92	QP
0.2059	24.09	9.76	33.85	53.37	-19.52	AVG
0.6620	34.63	9.74	44.37	56.00	-11.63	QP
0.6660	19.37	9.74	29.11	46.00	-16.89	AVG
1.3380	33.55	9.75	43.30	56.00	-12.70	QP
1.3619	19.21	9.75	28.96	46.00	-17.04	AVG
12.0938	33.95	10.05	44.00	60.00	-16.00	QP
12.5059	16.98	10.06	27.04	50.00	-22.96	AVG
21.1858	10.27	10.33	20.60	50.00	-29.40	AVG
21.3260	33.75	10.36	44.11	60.00	-15.89	QP

Remark:

1. All readings are Quasi-Peak and Average values.
2. Factor = Insertion Loss + Cable Loss.

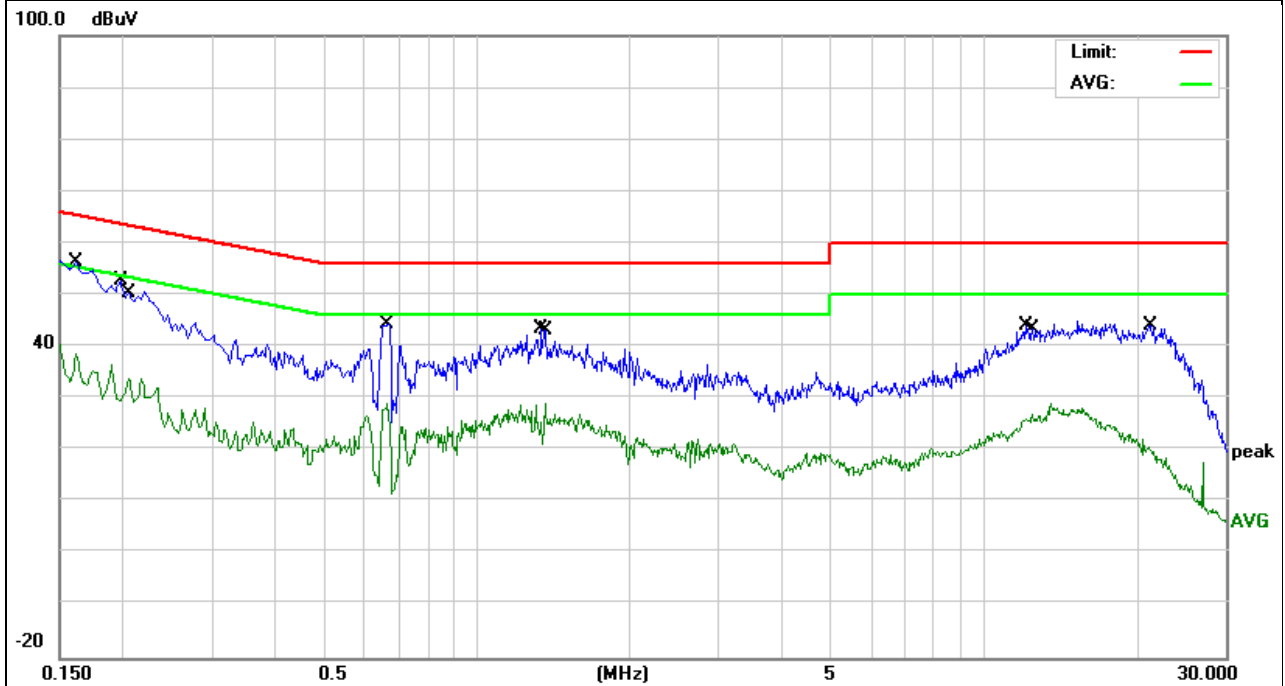

EUT:	Handheld Device	Model Name. :	GT50VH2
Temperature:	26 °C	Relative Humidity:	54%
Pressure:	1010hPa	Test Date:	2018-7-10
Test Mode:	Mode 1	Phase :	L
Test Voltage:	DC 5V from PC AC240V/60Hz		

Frequency (MHz)	Reading Level (dBμV)	Correct Factor (dB)	Measure-ment (dBμV)	Limits (dBμV)	Margin (dB)	Remark
0.6179	38.57	9.74	48.31	56.00	-7.69	QP
0.6179	28.81	9.74	38.55	46.00	-7.45	AVG
0.6740	42.06	9.74	51.80	56.00	-4.20	QP
0.6740	33.20	9.74	42.94	46.00	-3.06	AVG
0.8218	35.59	9.74	45.33	56.00	-10.67	QP
0.8298	20.77	9.74	30.51	46.00	-15.49	AVG
1.3500	41.20	9.75	50.95	56.00	-5.05	QP
1.3500	29.42	9.75	39.17	46.00	-6.83	AVG
1.7459	20.97	9.77	30.74	46.00	-15.26	AVG
1.7980	35.83	9.78	45.61	56.00	-10.39	QP
11.9977	36.09	10.05	46.14	60.00	-13.86	QP
12.0977	22.01	10.05	32.06	50.00	-17.94	AVG

Remark:

1. All readings are Quasi-Peak and Average values.
2. Factor = Insertion Loss + Cable Loss.

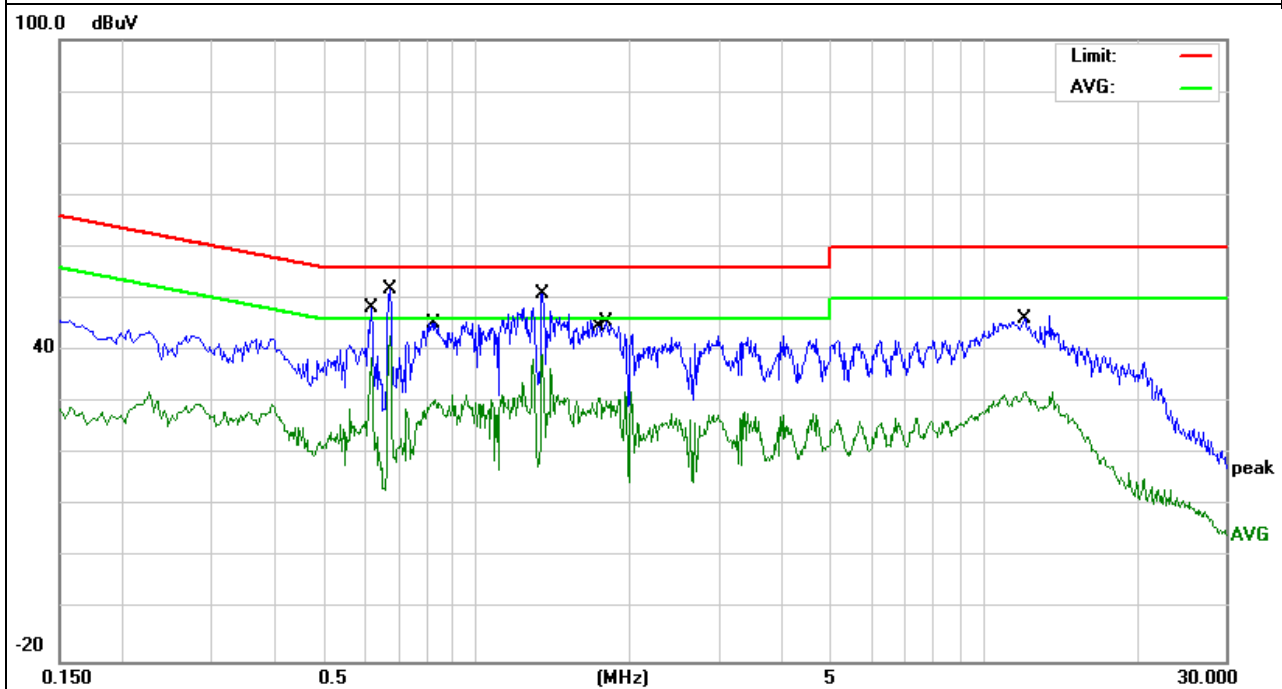

EUT:	Handheld Device	Model Name. :	GT50VH2
Temperature:	26 °C	Relative Humidity:	54%
Pressure:	1010hPa	Test Date:	2018-7-10
Test Mode:	Mode 1	Phase :	N
Test Voltage:	DC 5V from PC AC240V/60Hz		

Frequency (MHz)	Reading Level (dBμV)	Correct Factor (dB)	Measure-ment (dBμV)	Limits (dBμV)	Margin (dB)	Remark
0.5100	12.07	9.75	21.82	46.00	-24.18	AVG
0.5140	30.27	9.75	40.02	56.00	-15.98	QP
0.6139	22.95	9.75	32.70	46.00	-13.30	AVG
0.6179	35.14	9.75	44.89	56.00	-11.11	QP
0.6700	35.37	9.75	45.12	56.00	-10.88	QP
0.6740	27.67	9.75	37.42	46.00	-8.58	AVG
1.3460	37.02	9.76	46.78	56.00	-9.22	QP
1.3460	27.06	9.76	36.82	46.00	-9.18	AVG
1.5660	18.29	9.78	28.07	46.00	-17.93	AVG
1.6220	33.46	9.78	43.24	56.00	-12.76	QP
11.9419	37.16	10.07	47.23	60.00	-12.77	QP
12.0699	19.18	10.07	29.25	50.00	-20.75	AVG

Remark:

1. All readings are Quasi-Peak and Average values.
2. Factor = Insertion Loss + Cable Loss.

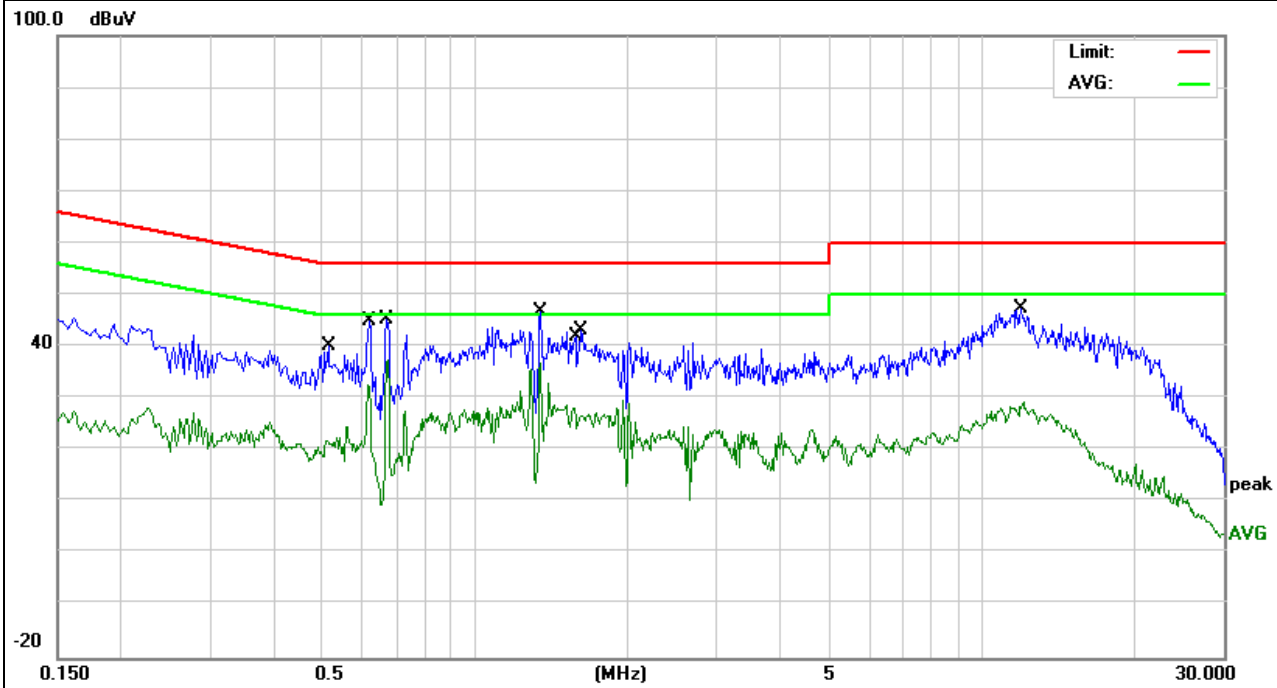

3.2 RADIATED EMISSION MEASUREMENT

3.2.1 LIMITS OF RADIATED EMISSION MEASUREMENT

FREQUENCY (MHz)	Class A (at 10m)	Class B (at 3m)
	dBuV/m	dBuV/m
30 ~ 88	39.0	40.0
88 ~ 216	43.5	43.5
216 ~ 960	46.5	46.0
Above 960	49.5	54.0

Notes:

- (1) The limit for radiated test was performed according to as following:
FCC PART 15B /ICES-003.
- (2) The tighter limit applies at the band edges.
- (3) Emission level (dBuV/m)=20log Emission level (uV/m).

3.2.2 TEST PROCEDURE

Test Arrangement for Radiated Emissions up to 1 GHz

- a. The EUT was placed on the top of a rotating table 0.8 meters above the ground at an accredited test facility. The table was rotated 360 degrees to determine the position of the highest radiation.
- b. The EUT was set 3 meters away from the interference-receiving antenna, which was mounted on the top of a variable-height antenna tower.
- c. The antenna is a broadband antenna, and its height is varied from one meter to four meters above the ground to determine the maximum value of the field strength. Both horizontal and vertical polarizations of the antenna are set to make the measurement.
- d. For each suspected emission, the EUT was arranged to its worst case and then the antenna was tuned to heights from 1 meter to 4 meters and the rotatable table was turned from 0 degrees to 360 degrees to find the maximum reading.

Note: The resolution bandwidth and video bandwidth of test receiver/spectrum analyzer is 120kHz for quasi-peak detection (QP) at frequency below 1GHz.

Test Arrangement for Radiated Emissions above 1 GHz.

- a. The EUT was placed on the top of a rotating table 0.8 meters above the ground at an accredited chamber room. The table was rotated 360 degrees to determine the position of the highest radiation.
- b. The EUT was set 3 meters away from the interference-receiving antenna, which was mounted on the top of a variable-height antenna tower.
- c. The height of antenna can be varied from one meter to four meters, the height of adjustment depends on the EUT height and the antenna 3dB beamwidth both, to detect the maximum value of the field strength.Both horizontal and vertical polarizations of the antenna are set to make the measurement.
- d. For each suspected emission, the EUT was arranged to its worst case and then the antenna was tuned to heights and the rotatable table was turned from 0 degrees to 360 degrees to find the maximum reading.

Note: For the hand-held device, the EUT should be measured for all 3 axes and only the worst case is recorded in the report.

During the radiated emission test, the Spectrum Analyzer was set with the following configurations:

Frequency Band (MHz)	Function	Resolution bandwidth	Video Bandwidth
30 to 1000	QP	120 kHz	300 kHz
Above 1000	Peak	1 MHz	1 MHz
	Avg	1 MHz	10 Hz

3.2.3 TEST SETUP

For Radiated Emission 30~1000MHz

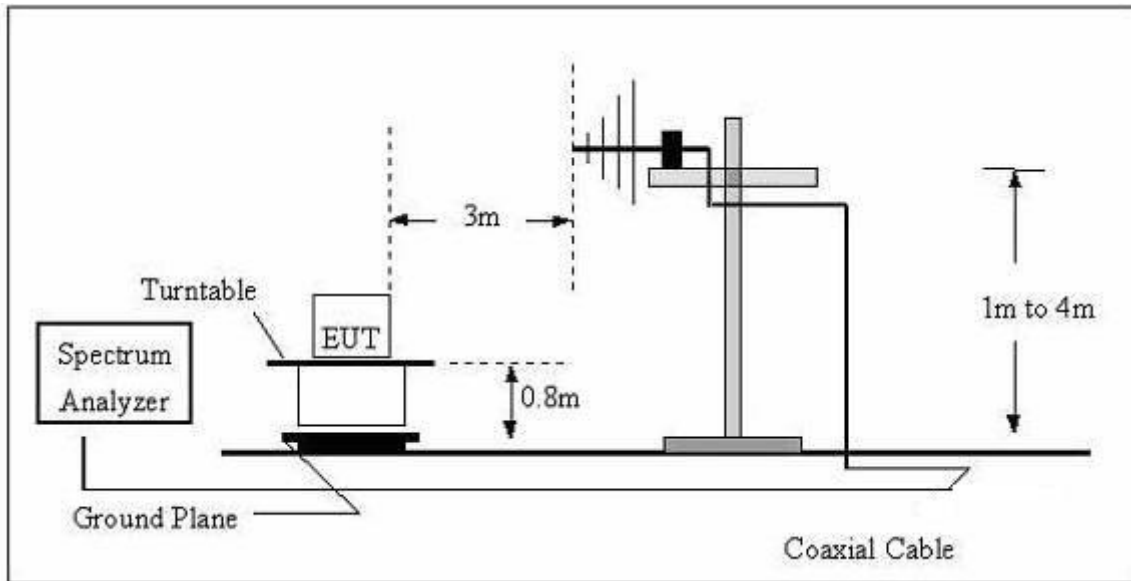

(B) Radiated Emission Test Set-Up Frequency Above 1GHz

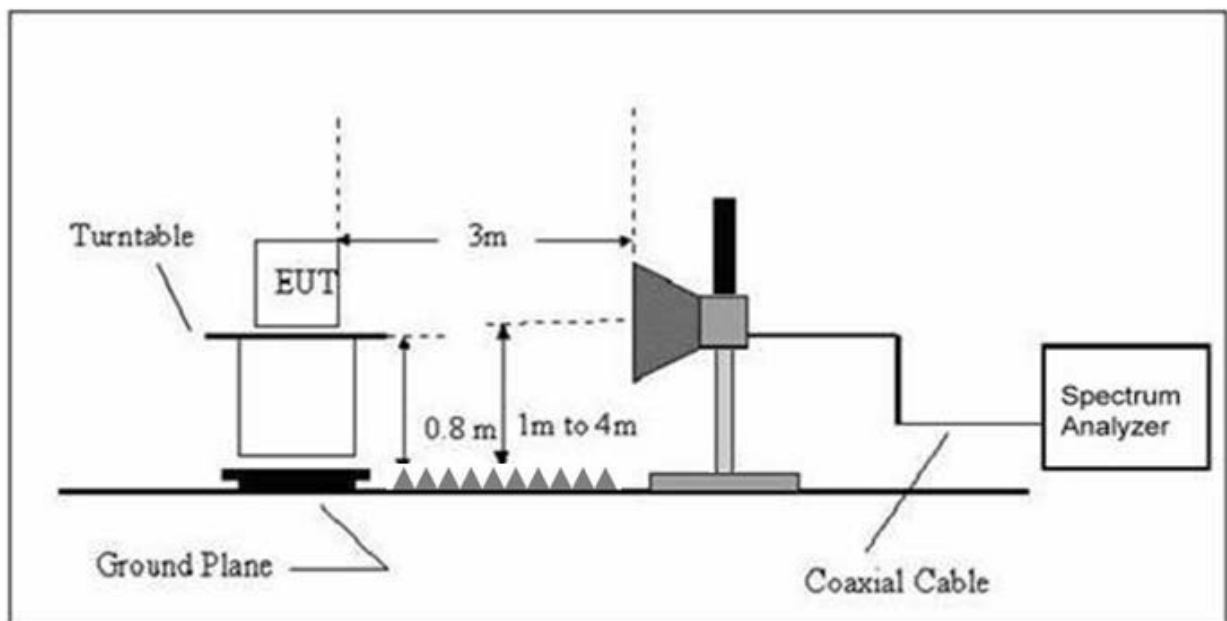

3.2.4 TEST RESULTS

TEST RESULTS (30~1000 MHz)

EUT:	Handheld Device	Model Name:	GT50VH2
Temperature:	24 °C	Relative Humidity:	54%
Pressure:	1010 hPa	Test Date :	2018-7-10
Test Mode :	Mode 1	Polarization :	Horizontal
Test Power :	DC 5V from PC AC120V/60Hz		

Polar (H/V)	Frequency	Meter Reading	Factor	Emission Level	Limits	Margin	Remark
	(MHz)	(dBuV)	(dB)	(dBuV/m)	(dBuV/m)	(dB)	
H	88.6524	14.34	10.08	24.42	43.50	-19.08	QP
H	185.7882	25.73	10.68	36.41	43.50	-7.09	QP
H	309.9977	16.48	16.35	32.83	46.00	-13.17	QP
H	558.7302	6.84	24.38	31.22	46.00	-14.78	QP
H	750.1082	7.70	27.47	35.17	46.00	-10.83	QP
H	965.5421	7.02	31.22	38.24	54.00	-15.76	QP

Remark:
Factor = Antenna Factor + Cable Loss - Amplifier.

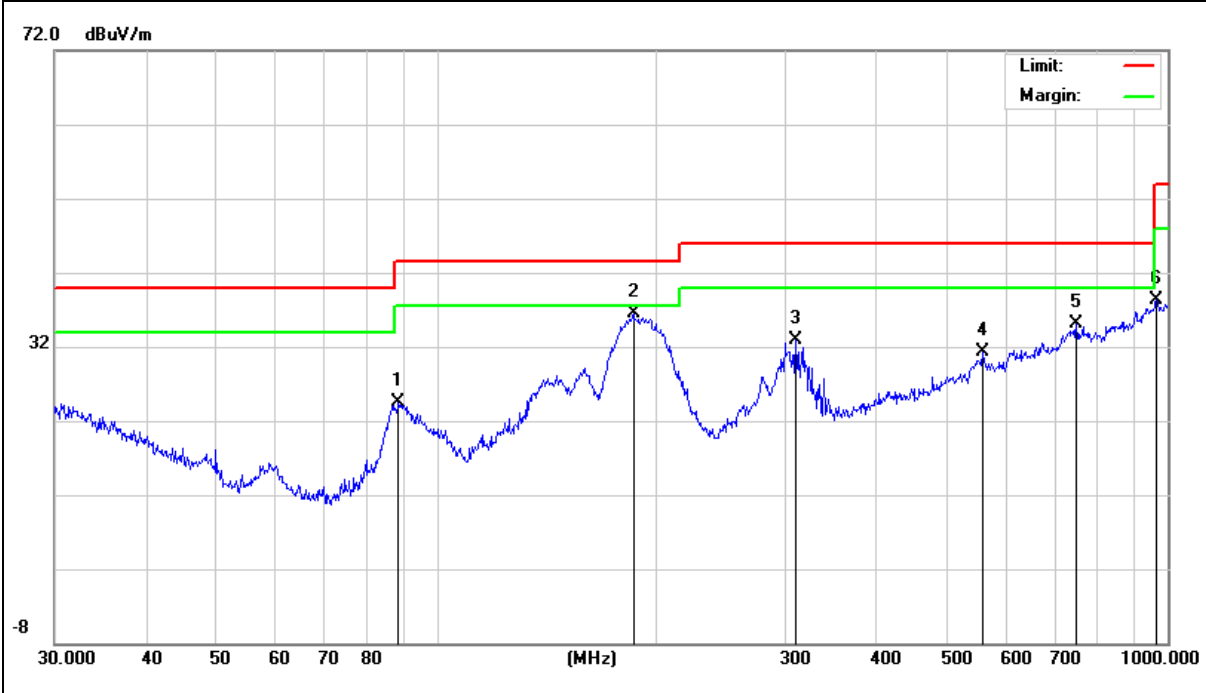

EUT:	Handheld Device	Model Name :	GT50VH2
Temperature:	24 °C	Relative Humidity:	54%
Pressure:	1010 hPa	Test Date :	2018-7-10
Test Mode :	Mode 1	Polarization :	Vertical
Test Power :	DC 5V from PC AC120V/60Hz		

Polar (H/V)	Frequency	Meter Reading	Factor	Emission Level	Limits	Margin	Remark
	(MHz)	(dBuV)	(dB)	(dBuV/m)	(dBuV/m)	(dB)	
V	33.6802	8.41	17.29	25.70	40.00	-14.30	QP
V	47.8260	18.06	11.32	29.38	40.00	-10.62	QP
V	59.8588	22.60	6.50	29.10	40.00	-10.90	QP
V	86.5029	19.61	10.01	29.62	40.00	-10.38	QP
V	177.5092	28.20	10.82	39.02	43.50	-4.48	QP
V	306.7537	11.28	16.26	27.54	46.00	-18.46	QP

Remark:

Factor = Antenna Factor + Cable Loss - Amplifier.

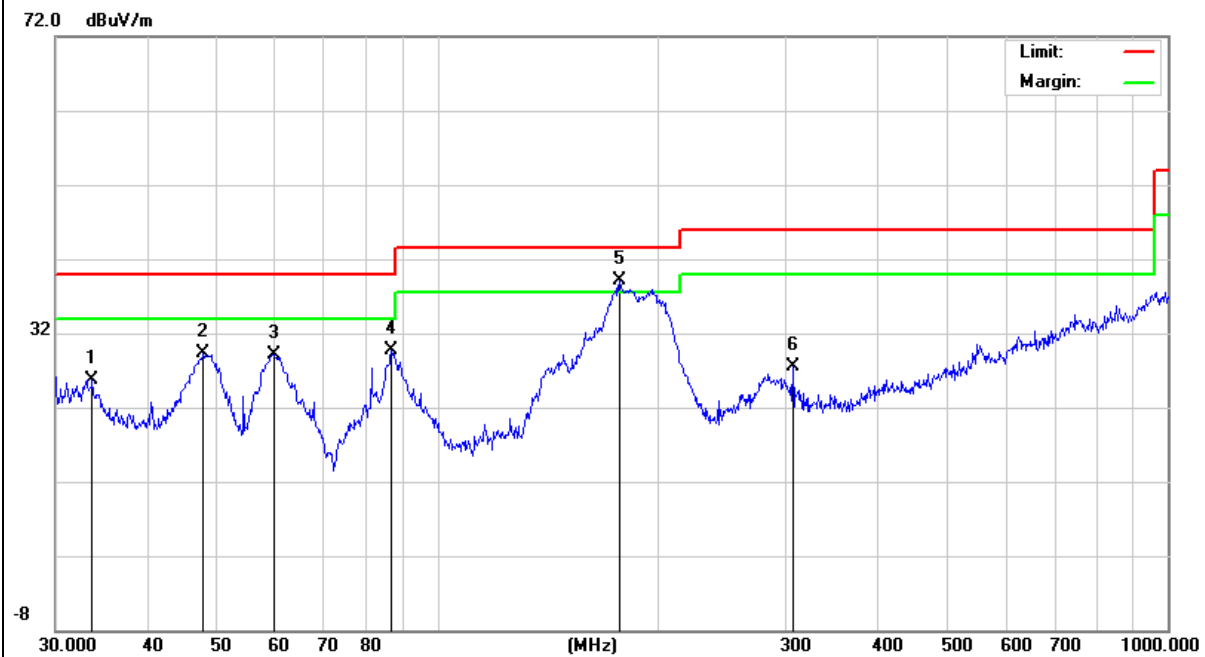

3.2.5 TEST RESULTS(1000~6500MHz)

EUT:	Handheld Device	Model Name :	GT50VH2
Temperature:	24 °C	Relative Humidity:	54%
Pressure:	1010 hPa	Test Date :	2018-7-10
Test Mode :	Mode 1		
Test Power :	DC 5V from PC AC120V/60Hz		

All the modulation modes have been tested, and the worst result was report as below:

Polar (H/V)	Frequency	Reading	Correct	Result	Limit	Over Limit	Remark
	(MHz)	(dBuV/m)	dB/m	(dBuV/m)	(dBuV/m)	(dB)	
V	1212.50	42.57	-2.69	39.88	74.00	-34.12	Pk
V	1212.50	37.34	-2.69	34.65	54.00	-19.35	AV
V	2105.00	40.91	2.34	43.25	74.00	-30.75	Pk
V	2105.00	36.28	2.34	38.62	54.00	-15.38	AV
V	4187.50	38.19	8.88	47.07	74.00	-26.93	Pk
V	4187.50	33.24	8.88	42.12	54.00	-11.88	AV
V	4867.50	36.03	12.60	48.63	74.00	-25.37	Pk
V	4867.50	31.44	12.60	44.04	54.00	-9.96	AV
H	1212.50	42.48	-2.69	39.79	74.00	-34.21	Pk
H	1212.50	38.67	-2.69	35.98	54.00	-18.02	AV
H	2105.00	40.48	2.34	42.82	74.00	-31.18	Pk
H	2105.00	35.29	2.34	37.63	54.00	-16.37	AV
H	4187.50	38.30	8.88	47.18	74.00	-26.82	Pk
H	4187.50	33.64	8.88	42.52	54.00	-11.48	AV
H	4825.00	35.41	12.61	48.02	74.00	-25.98	Pk
H	4825.00	30.27	12.61	42.88	54.00	-11.12	AV

Remark:

Absolute Level= ReadingLevel+ Factor, Margin= Absolute Level – Limit.

The peak value is less than average limit, so average value is meet the requirements.

Note: Only the worst results data points are reported in the report.