



# FCC RADIO TEST REPORT

## FCC ID: 2ACC5-GT50VH2

**Product :** Handheld Device

**Trade Mark :** N/A

**Model Name :** GT50VH2

**Serial Model :** N/A

**Report No. :** SER180628704005E

### Prepared for

AMobile Intelligent Corp.

8F.-1, No.700, Zhongzheng Rd., Zhonghe Dist New Taipei City, 235 Taiwan

### Prepared by

Shenzhen NTEK Testing Technology Co., Ltd.

1/F, Building E, Fenda Science Park, Sanwei Community, Xixiang Street  
Bao'an District, Shenzhen 518126 P.R. China

Tel.: +86-755-6115 6588 Fax.: +86-755-6115 6599

Website: <http://www.ntek.org.cn>

## TEST RESULT CERTIFICATION

**Applicant's name** ..... : AMobile Intelligent Corp.  
**Address** ..... : 8F.-1, No.700, Zhongzheng Rd., Zhonghe Dist New Taipei City,  
235 Taiwan

**Manufacturer's Name** ..... : AMobile Intelligent Corp.  
**Address** ..... : 8F.-1, No.700, Zhongzheng Rd., Zhonghe Dist New Taipei City,  
235 Taiwan

### Product description

**Product name**..... : Handheld Device  
**Model and/or type reference** : GT50VH2  
**Serial Model** : N/A

**Standards** ..... : FCC Part15.225

**Test procedure**..... ANSI C63.10-2013

This device described above has been tested by NTEK, and the test results show that the equipment under test (EUT) is in compliance with the FCC requirements. And it is applicable only to the tested sample identified in the report.

This report shall not be reproduced except in full, without the written approval of NTEK, this document may be altered or revised by NTEK, personnel only, and shall be noted in the revision of the document.

**Date of Test** ..... :

**Date (s) of performance of tests**..... : 28 Jun. 2018 ~ 24 Aug. 2018

**Date of Issue**..... : 27 Aug. 2018

**Test Result**..... : **Pass**

**Testing Engineer** : Loren Luo  
(Loren Luo)

**Technical Manager** : Jason Chen  
(Jason Chen)

**Authorized Signatory** : Sam Chen  
(Sam Chen)

**Table of Contents**

**Page**

<b>1 . SUMMARY OF TEST RESULTS</b>	<b>4</b>
1.1 TEST FACILITY	5
1.2 MEASUREMENT UNCERTAINTY	5
<b>2 . GENERAL INFORMATION</b>	<b>6</b>
2.1 GENERAL DESCRIPTION OF EUT	6
2.2 DESCRIPTION OF TEST MODES	7
2.3 BLOCK DIGRAM SHOWING THE CONFIGURATION OF SYSTEM TESTED	8
2.4 DESCRIPTION OF SUPPORT UNITS(CONDUCTED MODE)	9
2.5 EQUIPMENTS LIST FOR ALL TEST ITEMS	10
<b>3 . ANTENNA REQUIREMENT</b>	<b>11</b>
3.1 STANDARD REQUIREMENT	11
3.2 EUT ANTENNA	11
<b>4 . EMC EMISSION TEST</b>	<b>12</b>
4.1 CONDUCTED EMISSION MEASUREMENT	12
4.1.1 POWER LINE CONDUCTED EMISSION LIMITS	12
4.1.2 TEST CONFIGURATION	12
4.1.3 TEST PROCEDURE	12
4.1.4 TEST RESULT	13
4.2 RADIATED EMISSION MEASUREMENT	17
4.2.1 RADIATED EMISSION LIMITS	17
4.2.2 TEST PROCEDURE	18
4.2.3 DEVIATION FROM TEST STANDARD	18
4.2.4 TEST SETUP	19
4.2.5 TEST RESULTS (BELOW 30MHZ)	20
4.2.6 TEST RESULTS (BETWEEN 30 – 1000 MHZ)	22
<b>5 . BANDWIDTH TEST</b>	<b>24</b>
5.1 TEST PROCEDURE	24
5.2 DEVIATION FROM STANDARD	24
5.3 TEST SETUP	24
5.4 TEST RESULTS	25
<b>6. FREQUENCY TOLERANCE</b>	<b>26</b>

## 1. SUMMARY OF TEST RESULTS

Test procedures according to the technical standards:

FCC Part15, Subpart C (15.231)			
Standard Section	Test Item	Judgment	Remark
15.207	Conducted Emission	Pass	
15.205(a) 15.209 15.225	Radiated Spurious Emission	Pass	
15.225	20dB Bandwidth	Pass	
15.225	Frequency Tolerance	Pass	
15.203	Antenna Requirement	Pass	

**NOTE:**

(1) " N/A" denotes test is not applicable in this Test Report.

### 1.1 TEST FACILITY

All measurement facilities used to collect the measurement data are located at 1/F, Building E, Fenda Science Park, Sanwei Community, Xixiang Street, Bao'an District, Shenzhen 518126 P.R. China.

The sites are constructed in conformance with the requirements of ANSI C63.7, ANSI C63.10 and CISPR Publication 22.

Site Description

CNAS-Lab. : The Laboratory has been assessed and proved to be in compliance with CNAS-CL01:2006 (identical to ISO/IEC 17025:2005)  
The Certificate Registration Number is L5516.

IC-Registration The Certificate Registration Number is 9270A-1.

FCC- Accredited Test Firm Registration Number: 463705.  
Designation Number: CN1184

A2LA-Lab. The Certificate Registration Number is 4298.01  
This laboratory is accredited in accordance with the recognized International Standard ISO/IEC 17025:2005 General requirements for the competence of testing and calibration laboratories.  
This accreditation demonstrates technical competence for a defined scope and the operation of a laboratory quality management system  
(refer to joint ISO-ILAC-IAF Communiqué dated 8 January 2009).

Name of Firm : Shenzhen NTEK Testing Technology Co., Ltd.

Site Location : 1/F, Building E, Fenda Science Park, Sanwei Community, Xixiang Street, Bao'an District, Shenzhen 518126 P.R. China.

### 1.2 MEASUREMENT UNCERTAINTY

The reported uncertainty of measurement  $y \pm U$ , where expanded uncertainty  $U$  is based on a standard uncertainty multiplied by a coverage factor of  $k=2$ , providing a level of confidence of approximately 95 %.

No.	Item	Uncertainty
1	Conducted Emission Test	±1.38dB
2	RF power,conducted	±0.16dB
3	Spurious emissions,conducted	±0.21dB
4	All emissions,radiated(<1G)	±4.68dB
5	All emissions,radiated(>1G)	±4.89dB
6	Temperature	±0.5°C
7	Humidity	±2%

## 2. GENERAL INFORMATION

### 2.1 GENERAL DESCRIPTION OF EUT

Equipment	Handheld Device
Trade Mark	N/A
Model Name	GT50VH2
Serial Model	N/A
Model Difference	N/A
Product Description	The EUT is a Handheld Device
	Operation Frequency: 13.56MHz
	Modulation Type: ASK
	Number Of Channel 1CH.
	Antenna Designation: Loop Antenna
Antenna Gain(Peak) 1.0 dBi	
Adapter	Model:PSAF10R-050Q Input: 100-240V~50-60Hz 0.3A Output: 5V---2.0A
Battery	DC 3.8V/5200mAh
Rating	DC 3.8V from Battery or DC 5V from USB Port.
HW Version	GT-500V_MB_V1.1_170929
SW Version	V018.08.01

Note:

1. For a more detailed features description, please refer to the manufacturer's specifications or the User's Manual.

- 2.

Table for Filed Antenna

Ant	Brand	Model Name	Antenna Type	Connector	Gain (dBi)	NOTE
1	N/A	N/A	Loop Antenna	N/A	1.0	Antenna

## 2.2 DESCRIPTION OF TEST MODES

To investigate the maximum EMI emission characteristics generates from EUT, the test system was pre-scanning tested base on the consideration of following EUT operation mode or test configuration mode which possible have effect on EMI emission level. Each of these EUT operation mode(s) or test configuration mode(s) mentioned above was evaluated respectively.

Pretest Mode	Description
Mode 1	TX-13.56MHz

For Conducted Emission	
Final Test Mode	Description
Mode 1	TX-13.56MHz

For Radiated Emission	
Final Test Mode	Description
Mode 1	TX-13.56MHz

### 2.3 BLOCK DIGRAM SHOWING THE CONFIGURATION OF SYSTEM TESTED

For AC Conducted Emission Mode

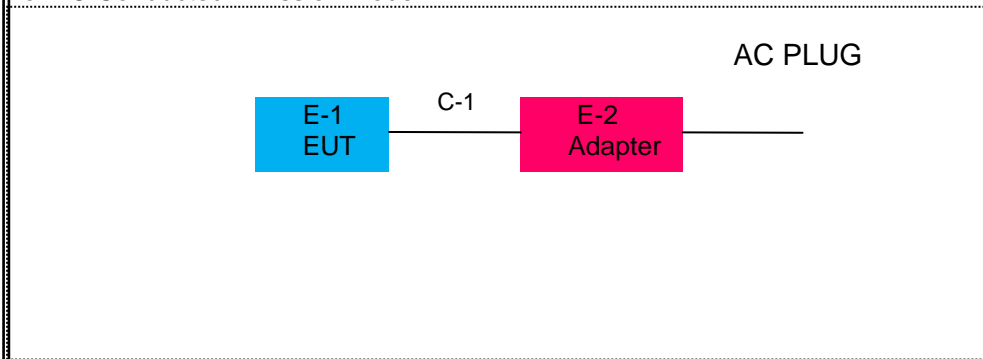

For Radiated Test Cases

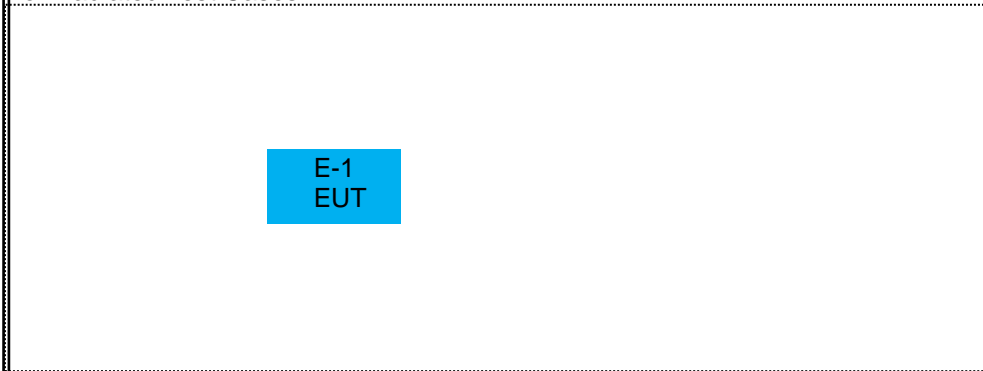

For Conducted Test Cases

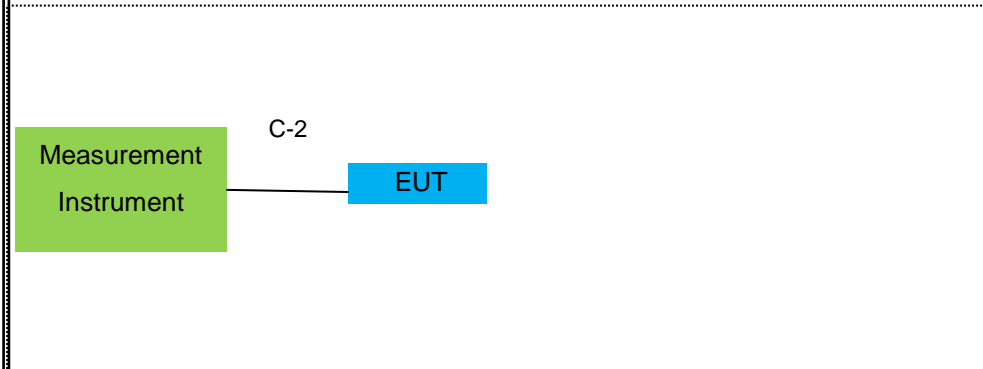

Note: The temporary antenna connector is soldered on the PCB board in order to perform conducted tests and this temporary antenna connector is listed in the equipment list.



**2.4 DESCRIPTION OF SUPPORT UNITS(CONDUCTED MODE)**

The EUT has been tested as an independent unit together with other necessary accessories or support units. The following support units or accessories were used to form a representative test configuration during the tests.

Item	Equipment	Brand	Model/Type No.	Series No.	Note
E-1	Handheld Device	N/A	GT50VH2	N/A	EUT
E-2	Adapter	N/A	PSAF10R-050Q	N/A	Peripherals

Item	Shielded Type	Ferrite Core	Length	Note
C-1	NO	NO	1.0m	
C-2	NO	NO	0.5m	

Note:

- (1) The support equipment was authorized by Declaration of Confirmation.
- (2) For detachable type I/O cable should be specified the length in cm in 『Length』 column.

## 2.5 EQUIPMENTS LIST FOR ALL TEST ITEMS

### Radiation & Conducted Test equipment

Item	Kind of Equipment	Manufacturer	Type No.	Serial No.	Last calibration	Calibrated until	Calibration period
1	Spectrum Analyzer	Agilent	E4407B	MY45108040	2018.05.19	2019.05.18	1 year
2	Spectrum Analyzer	Agilent	N9020A	MY49100060	2017.10.26	2018.10.25	1 year
3	Spectrum Analyzer	R&S	FSV40	101417	2017.10.26	2018.10.25	1 year
4	Test Receiver	R&S	ESPI7	101318	2018.05.19	2019.05.18	1 year
5	Bilog Antenna	TESEQ	CBL6111D	31216	2018.04.08	2019.04.07	1 year
6	50Ω Coaxial Switch	Anritsu	MP59B	6200983705	2018.05.19	2020.05.18	3 year
7	Horn Antenna	EM	EM-AH-10180	2011071402	2018.04.08	2019.04.07	1 year
8	Active Loop Antenna	SCHWARZBECK	FMZB 1519B	055	2017.12.06	2018.12.06	1 year
9	LF Cable	N/A	R-03	N/A	2018.06.05	2021.06.05	3 year
10	PSG Analog Signal Generator	Agilent	E8257D	MY51110112	2018.08.05	2019.08.04	1 year
11	Test Cable (9KHz-30MHz)	N/A	R-01	N/A	2017.04.21	2020.04.20	3 year
12	Test Cable (30MHz-1GHz)	N/A	R-02	N/A	2017.04.21	2020.04.20	3 year

Note:

1. We will use the temporary antenna connector (soldered on the PCB board) When conducted test And this temporary antenna connector is listed within the instrument list
2. Each piece of equipment is scheduled for calibration once a year except the Test Cable & Aux Equipment which is scheduled for calibration every 3 years.

### **3. ANTENNA REQUIREMENT**

#### **3.1 STANDARD REQUIREMENT**

15.203 requirement: For intentional device, according to 15.203: an intentional radiator shall be designed to ensure that no antenna other than that furnished by the responsible party shall be used with the device.

#### **3.2 EUT ANTENNA**

The EUT antenna is permanent attached antenna. It comply with the standard requirement.

## 4. EMC EMISSION TEST

### 4.1 CONDUCTED EMISSION MEASUREMENT

#### 4.1.1 POWER LINE CONDUCTED EMISSION Limits (Frequency Range 150KHz-30MHz)

Frequency(MHz)	Conducted Emission Limit	
	Quasi-peak	Average
0.15-0.5	66-56*	56-46*
0.5-5.0	56	46
5.0-30.0	60	50

Note: 1. \*Decreases with the logarithm of the frequency  
 2. The lower limit shall apply at the transition frequencies  
 3. The limit decreases in line with the logarithm of the frequency in the range of 0.15 to 0.50MHz.

#### 4.1.2 TEST CONFIGURATION

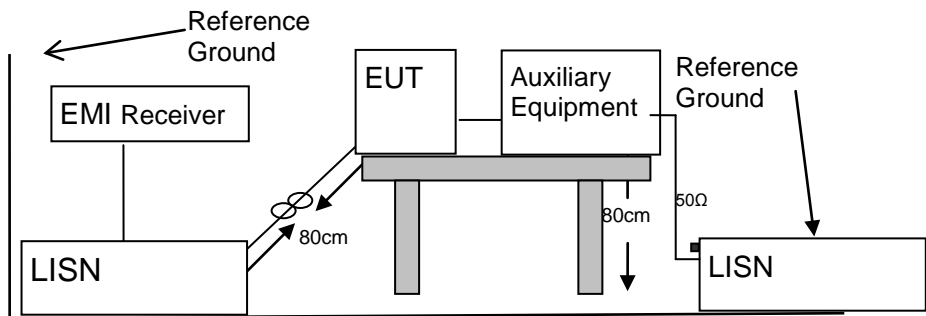

#### 4.1.3 TEST PROCEDURE

According to the requirements in Section 13.1.4.1 of ANSI C63.10-2013 Conducted emissions the EUT measured in the frequency range between 0.15 MHz and 30 MHz using CISPR Quasi-Peak and average detector mode.

1. The EUT was placed 0.4 meter from the conducting wall of the shielding room.
2. The EUT was placed on a table which is 0.8m above ground plane.
3. Connect EUT to the power mains through a line impedance stabilization network (LISN). All other support equipments powered from additional LISN(s). The LISN provide 50 Ohm/ 50uH of coupling impedance for the measuring instrument.
4. Interconnecting cables that hang closer than 40 cm to the ground plane shall be folded back and forth in the center forming a bundle 30 to 40cm long.
5. I/O cables that are not connected to a peripheral shall be bundled in the center. The end of the cable may be terminated, if required, using the correct terminating impedance. The overall length shall not exceed 1 m.
6. LISN at least 80 cm from nearest part of EUT chassis.
7. The frequency range from 150KHz to 30MHz was searched.
8. Set the test-receiver system to Peak Detect Function and specified bandwidth(IF bandwidth=9KHz) with Maximum Hold Mode
9. For the actual test configuration, please refer to the related Item –EUT Test Photos.

**4.1.4 TEST RESULT**

EUT :	Handheld Device	Model Name :	GT50VH2
Temperature :	26 °C	Relative Humidity :	54%
Pressure :	1010hPa	Phase :	L
Test Voltage :	DC 5V from adapter AC 120V/60Hz	Test Mode :	Mode 1

Frequency (MHz)	Reading Level (dBμV)	Correct Factor (dB)	Measure-ment (dBμV)	Limits (dBμV)	Margin (dB)	Remark
0.15	44.36	10.12	54.48	65.99	-11.51	QP
0.15	26.4	10.12	36.52	55.99	-19.47	AVG
0.2179	33.45	10.13	43.58	62.89	-19.31	QP
0.2179	17.31	10.13	27.44	52.89	-25.45	AVG
0.3699	31.56	10.07	41.63	58.5	-16.87	QP
0.3699	23.03	10.07	33.1	48.5	-15.4	AVG
0.4939	27.26	9.81	37.07	56.1	-19.03	QP
0.4939	16.21	9.81	26.02	46.1	-20.08	AVG
3.5899	38.98	9.75	48.73	56	-7.27	QP
3.5899	24.43	9.75	34.18	46	-11.82	AVG
12.4938	22.35	9.82	32.17	60	-27.83	QP
12.4938	16.08	9.82	25.9	50	-24.1	AVG

Remark:

1. All readings are Quasi-Peak and Average values.
2. Factor = Insertion Loss + Cable Loss.

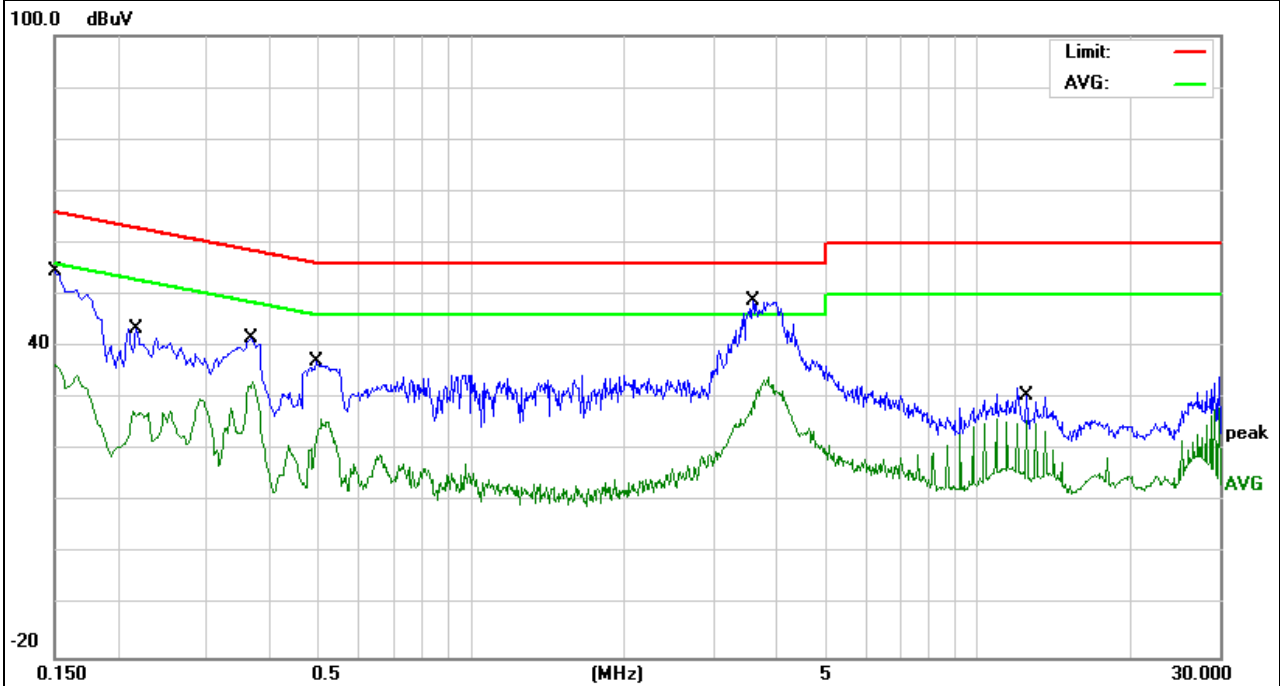

EUT :	Handheld Device	Model Name :	GT50VH2
Temperature :	26 °C	Relative Humidity :	54%
Pressure :	1010hPa	Phase :	N
Test Voltage :	DC 5V from adapter AC 120V/60Hz	Test Mode :	Mode 1

Frequency (MHz)	Reading Level (dBμV)	Correct Factor (dB)	Measure-ment (dBμV)	Limits (dBμV)	Margin (dB)	Remark
0.15	45.28	10.08	55.36	65.99	-10.63	QP
0.15	31.31	10.08	41.39	55.99	-14.6	AVG
0.226	34.44	10.05	44.49	62.59	-18.1	QP
0.226	21.62	10.05	31.67	52.59	-20.92	AVG
0.3659	31.92	10.08	42	58.59	-16.59	QP
0.3659	22.94	10.08	33.02	48.59	-15.57	AVG
0.4979	26.69	9.82	36.51	56.03	-19.52	QP
0.4979	14.99	9.82	24.81	46.03	-21.22	AVG
3.97	39.66	9.72	49.38	56	-6.62	QP
3.97	24.83	9.72	34.55	46	-11.45	AVG
9.6178	27.25	9.76	37.01	60	-22.99	QP
9.6178	16.39	9.76	26.15	50	-23.85	AVG

Remark:

1. All readings are Quasi-Peak and Average values.
2. Factor = Insertion Loss + Cable Loss.

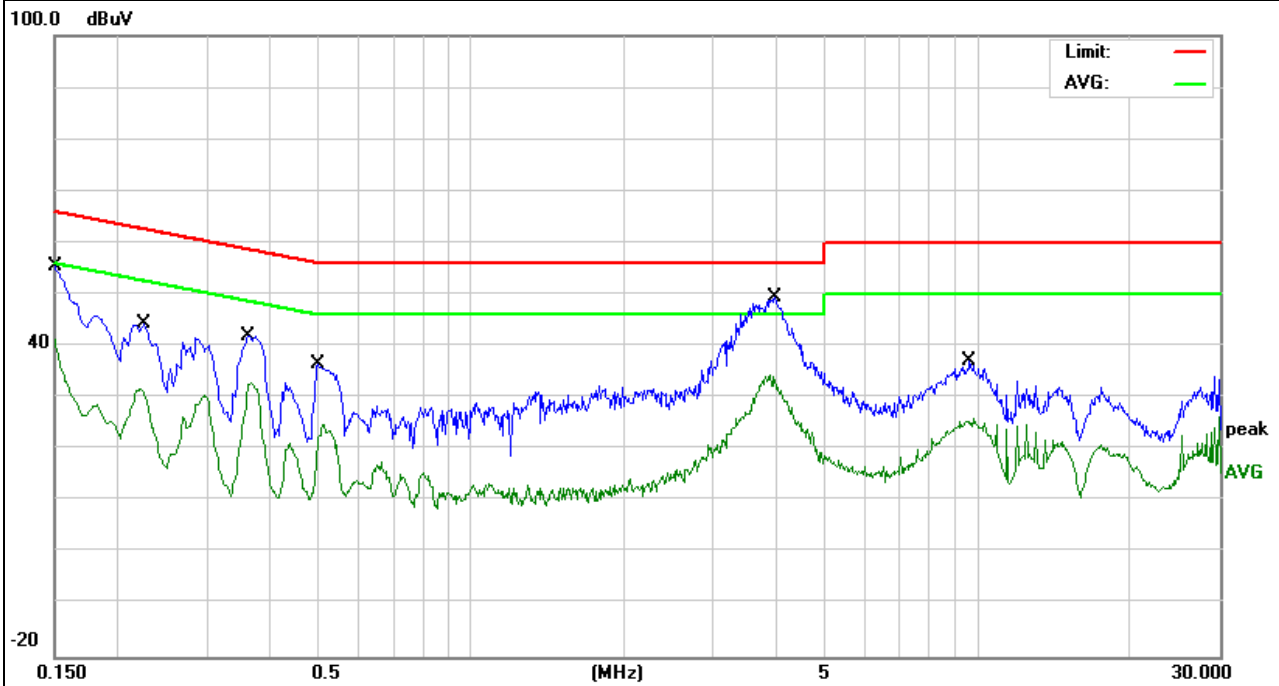

EUT :	Handheld Device	Model Name :	GT50VH2
Temperature :	26 °C	Relative Humidity :	54%
Pressure :	1010hPa	Phase :	L
Test Voltage :	DC 5V from adapter AC 240V/60Hz	Test Mode :	Mode 1

Frequency (MHz)	Reading Level (dBμV)	Correct Factor (dB)	Measure-ment (dBμV)	Limits (dBμV)	Margin (dB)	Remark
0.17	45.96	10.06	56.02	64.96	-8.94	QP
0.17	27.64	10.06	37.7	54.96	-17.26	AVG
0.202	42.73	10.02	52.75	63.52	-10.77	QP
0.202	27.2	10.02	37.22	53.52	-16.3	AVG
0.342	31.94	10.1	42.04	59.15	-17.11	QP
0.342	23.93	10.1	34.03	49.15	-15.12	AVG
0.454	30.54	9.93	40.47	56.8	-16.33	QP
0.454	21.26	9.93	31.19	46.8	-15.61	AVG
4.022	40.82	9.72	50.54	56	-5.46	QP
4.022	25.68	9.72	35.4	46	-10.6	AVG
9.3698	27.13	9.76	36.89	60	-23.11	QP
9.3698	15.82	9.76	25.58	50	-24.42	AVG

Remark:

1. All readings are Quasi-Peak and Average values.
2. Factor = Insertion Loss + Cable Loss.

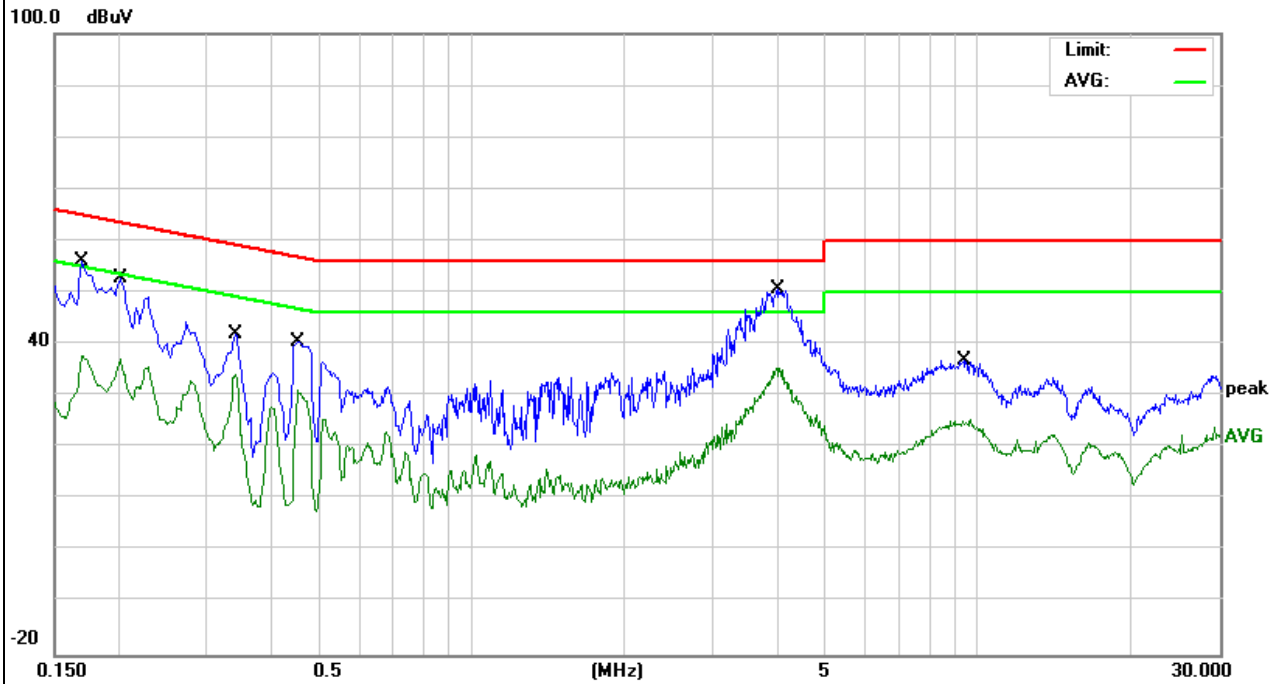

EUT :	Handheld Device	Model Name :	GT50VH2
Temperature :	26 °C	Relative Humidity :	54%
Pressure :	1010hPa	Phase :	N
Test Voltage :	DC 5V from adapter AC 240V/60Hz	Test Mode :	Mode 1

Frequency (MHz)	Reading Level (dBμV)	Correct Factor (dB)	Measure-ment (dBμV)	Limits (dBμV)	Margin (dB)	Remark
0.174	44.12	10.05	54.17	64.76	-10.59	QP
0.462	31.54	9.91	41.45	56.66	-15.21	AVG
4.038	41.45	9.72	51.17	56	-4.83	QP
0.234	26.51	10.06	36.57	52.3	-15.73	AVG
4.022	26.32	9.72	36.04	46	-9.96	QP

Remark:

1. All readings are Quasi-Peak and Average values.
2. Factor = Insertion Loss + Cable Loss.

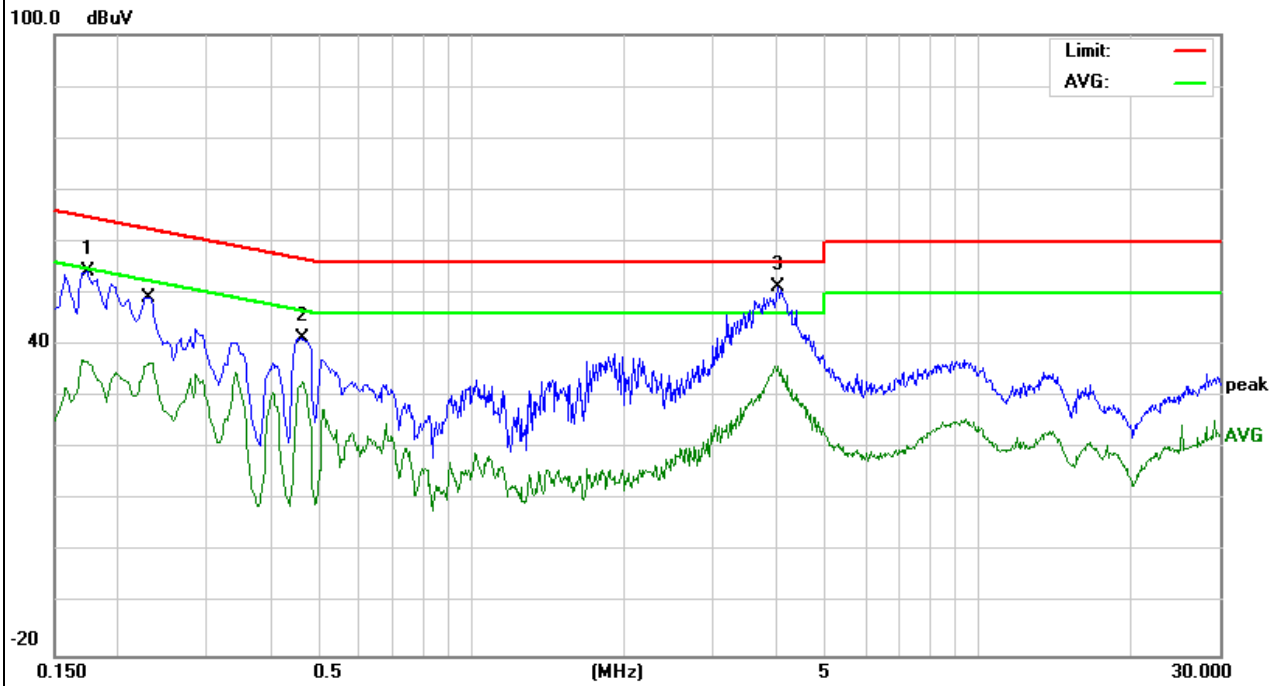



## 4.2 RADIATED EMISSION MEASUREMENT

### 4.2.1 Radiated Emission Limits ( FCC 15.209 )

Frequencies (MHz)	Field Strength (micorvolts/meter)	Measurement Distance (meters)
0.009~0.490	2400/F(KHz)	300
0.490~1.705	24000/F(KHz)	30
1.705~30.0	30	30
30~88	100	3
88~216	150	3
216~960	200	3
Above 960	500	3

Note:

- (1) The tighter limit applies at the band edges.
- (2) Emission level (dBuV/m)=20log Emission level (uV/m).

### LIMITS OF RADIATED EMISSION MEASUREMENT ( FCC 15.225)

- (a) The field strength of any emissions within the band 13.553-13.567 MHz shall not exceed 15,848 microvolts/meter at 30 meters, equal to 104dBuV/m at 3 meters.
- (b) Within the bands 13.410-13.553 MHz and 13.567-13.710 MHz, the field strength of any emissions shall not exceed 334 microvolts/meter at 30 meters, equal to 74.5dBuV/m at 3 meters.
- (c) Within the bands 13.110-13.410 MHz and 13.710-14.010 MHz the field strength of any emissions shall not exceed 106 microvolts/meter at 30 meters, equal to 60.5dBuV/m at 3 meters..
- (d) The field strength of any emissions appearing outside of the 13.110-14.010 MHz band shall not exceed the general radiated emission limits in § 15.209.

Spectrum Parameter	Setting
Attenuation	Auto
Start Frequency	1000 MHz
Stop Frequency	10th carrier harmonic
RB / VB (emission in restricted band)	1MHz / 1MHz for Peak

Receiver Parameter	Setting
Attenuation	Auto
Start ~ Stop Frequency	9kHz~150kHz / RB 200Hz for QP
Start ~ Stop Frequency	150kHz~30MHz / RB 9kHz for QP
Start ~ Stop Frequency	30MHz~1000MHz / RB 120kHz for QP

**4.2.2 TEST PROCEDURE**

- a. The measuring distance of at 3 m shall be used for measurements at frequency up to 1GHz And above 1GHz,
- b. The EUT was placed on the top of a rotating table 0.8 meters above the ground at a 3m meter. The table was rotated 360 degrees to determine the position of the highest radiation.
- c. The height of the equipment or of the substitution antenna shall be 0.8 m; the height of the test antenna shall vary between 1 m to 4 m.
- d. The initial step in collecting conducted emission data is a spectrum analyzer peak detector mode pre-scanning the measurement frequency range. Significant peaks are then marked and then Quasi Peak detector mode re-measured.
- e. If the Peak Mode measured value compliance with and lower than Quasi Peak Mode Limit, the EUT shall be deemed to meet QP Limits and then no additional QP Mode measurement performed.
- f. For the actual test configuration, please refer to the related Item –EUT Test Photos.

Note:

Both horizontal and vertical antenna polarities were tested and performed pretest to three orthogonal axis. The worst case emissions were reported

**4.2.3 DEVIATION FROM TEST STANDARD**

No deviation

### 4.2.4 TEST SETUP

(A) Radiated Emission Test-Up Frequency Below 30MHz

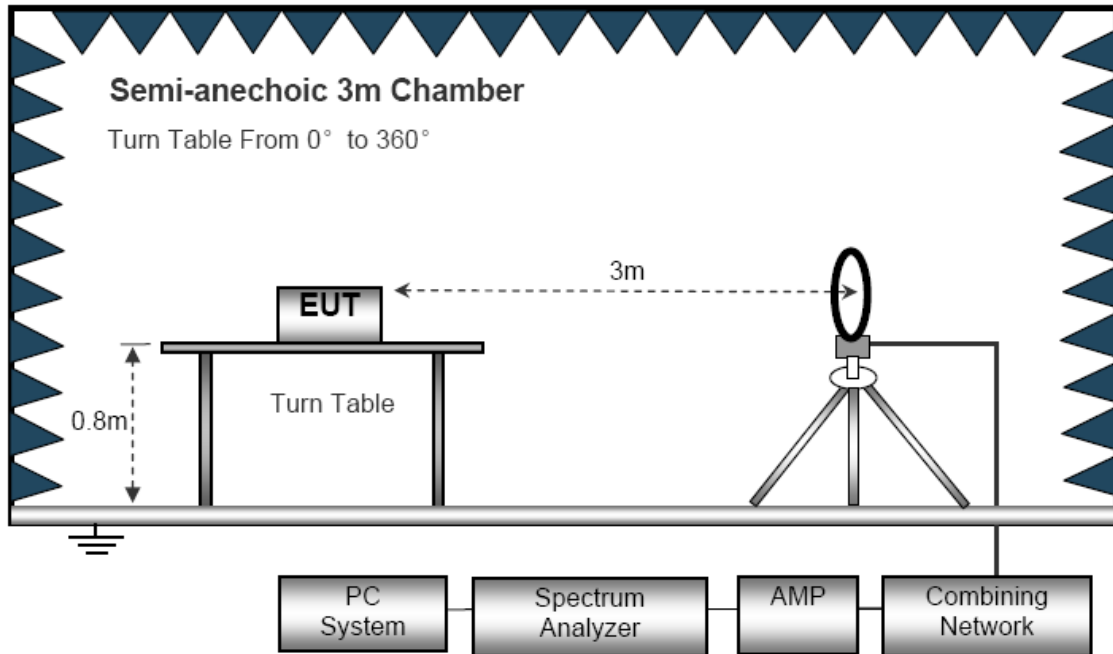

(B) Radiated Emission Test-Up Frequency 30MHz~1GHz

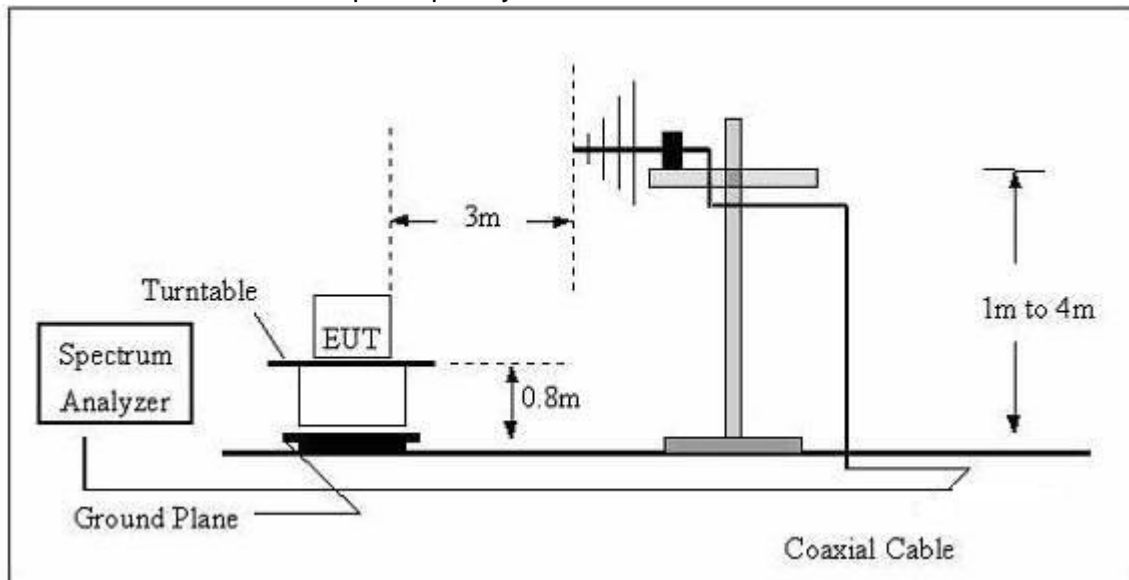

### 4.2.5 TEST RESULTS (BELOW 30MHz)

EUT :	Handheld Device	Model Name. :	GT50VH2
Temperature :	20 °C	Relative Humidity :	54%
Pressure :	1010 hPa	Test Voltage :	DC 3.8V
Test Mode :	TX-13.56MHz		

Freq.	Reading	Factor	Emission Level	Limit	Margin	Polar
(MHz)	(dBuV/m)	(dB)	(dBuV/m)	(dBuV/@3m)	(dB)	
13.5609	62	0	62	124.0 0	-62	X

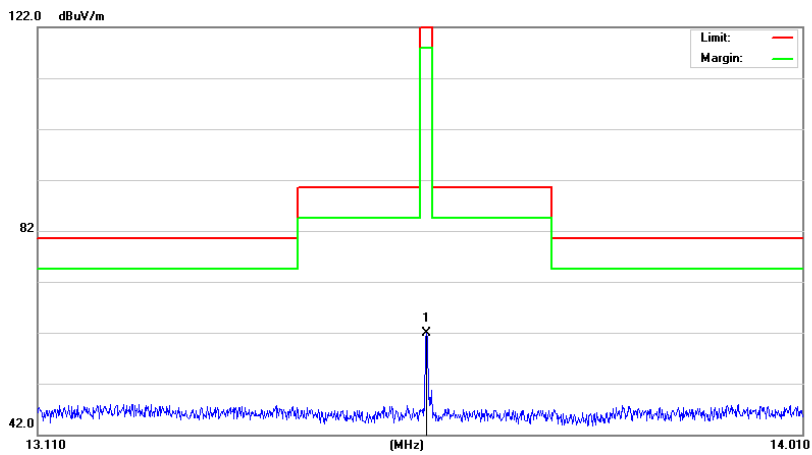

Freq.	Reading	Factor	Emission Level	Limit	Margin	Polar
(MHz)	(dBuV/m)	(dB)	(dBuV/m)	(dBuV/@3m)	(dB)	
13.5609	61.4	0	61.4	124.0 0	-62.6	Y

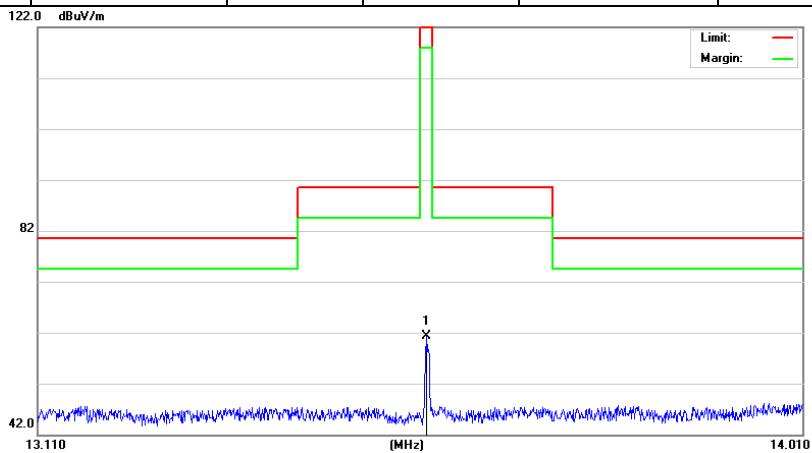

Freq.	Reading	Factor	Emission Level	Limit	Margin	Polar
(MHz)	(dBuV/m)	(dB)	(dBuV/m)	(dBuV/@3m)	(dB)	
13.5609	61.1	0	61.1	124.0 0	-62.9	Z

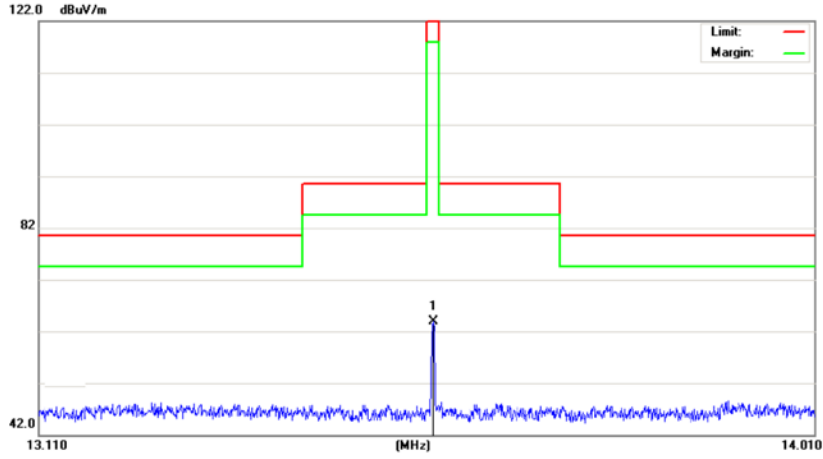

Spurious emissions at 9kHz~30MHz

Frequency Range	Frequency	Measurement results	Measurement results (calculated)	Limits	Margin	Detector
(MHz)	(MHz)	dB $\mu$ V @3m	dB $\mu$ V/m &30m	dB $\mu$ V/m @30m	(dB)	
0.490-1.705	1.157	28.74	18.74	26.34	-7.60	QP
1.705-30.0	5.291	23.25	13.25	29.54	-16.29	QP
1.705-30.0	21.654	32.26	22.56	29.54	-6.98	QP

**4.2.6 TEST RESULTS (BETWEEN 30 – 1000 MHZ)**

EUT :	Handheld Device	Model Name :	GT50VH2
Temperature :	20 °C	Relative Humidity :	54%
Pressure :	1010 hPa	Test Voltage :	DC 3.8V
Test Mode :	TX	Polarization :	Horizontal

Freq. (MHz)	Reading (dBµV/m)	Factor (dB)	Measurement (dBµV/m)	Limit (dBµV/m)	Over (dB)	Detector
31.62	7.35	18.32	25.67	40.00	-14.33	QP
138.87	18.66	13.32	31.98	43.50	-11.52	QP
176.27	19.10	10.81	29.91	43.50	-13.59	QP
300.37	16.04	16.09	32.13	46.00	-13.87	QP
326.74	15.94	16.69	32.63	46.00	-13.37	QP
665.80	10.02	24.99	35.01	46.00	-10.99	QP

Remark:

Factor = Antenna Factor + Cable Loss.

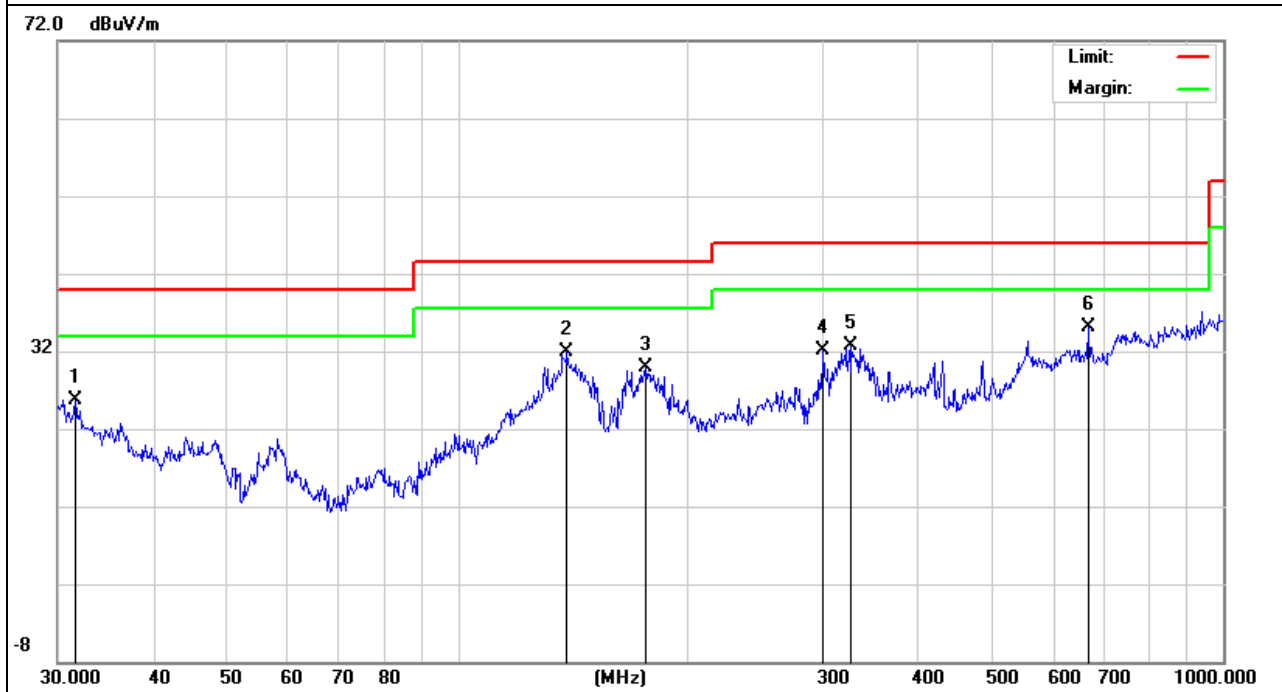

EUT :	Handheld Device	Model Name :	GT50VH2
Temperature :	20 °C	Relative Humidity :	54%
Pressure :	1010 hPa	Test Voltage :	DC 3.8V
Test Mode :	TX	Polarization :	Vertical

Freq. (MHz)	Reading (dBμV/m)	Factor (dB)	Measurement (dBμV/m)	Limit (dBμV/m)	Over (dB)	Detector
49.53	15.89	9.71	25.60	40.00	-14.40	QP
56.79	19.26	6.84	26.10	40.00	-13.90	QP
129.01	18.65	13.43	32.08	43.50	-11.42	QP
416.18	11.80	20.21	32.01	46.00	-13.99	QP
552.88	11.08	24.51	35.59	46.00	-10.41	QP
665.80	15.24	24.99	40.23	46.00	-5.77	QP

Remark:  
Factor = Antenna Factor + Cable Loss.

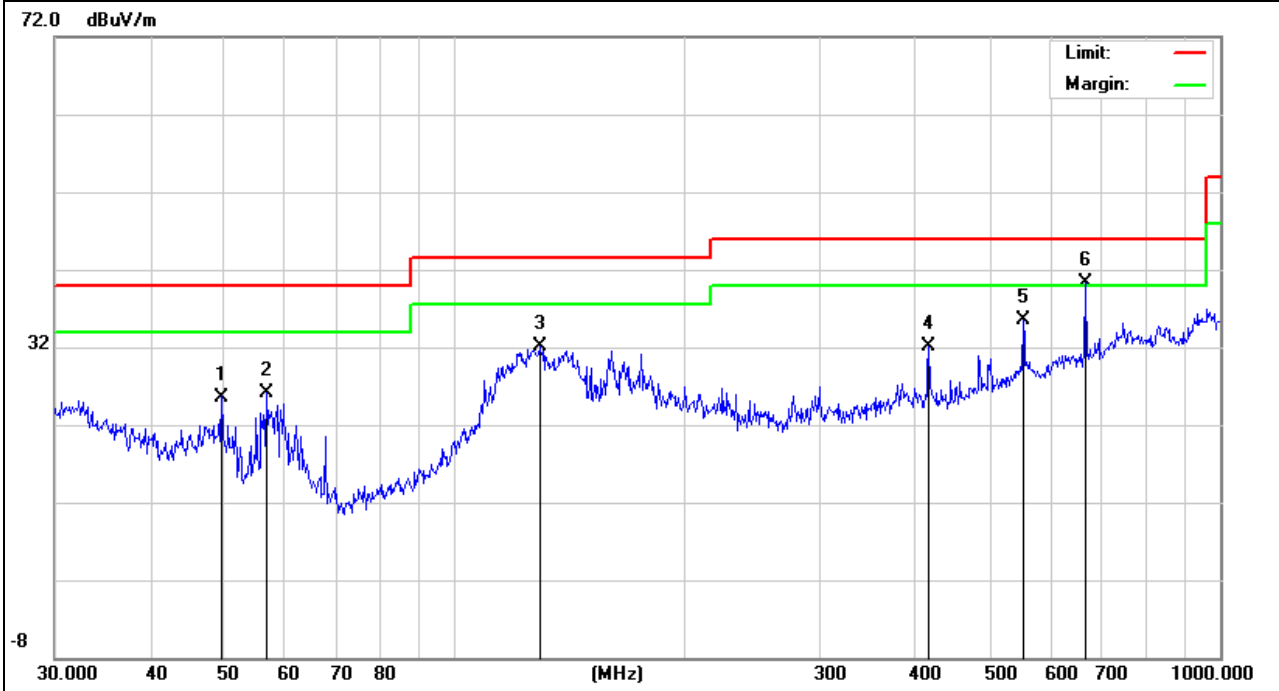

## 5. BANDWIDTH TEST

### 5.1 TEST PROCEDURE

1. The transmitter output (antenna port) was connected to the spectrum analyzer in peak mode.
2. 20dB Bandwidth the resolution bandwidth of 1 kHz and the video bandwidth of 1 kHz were used.
3. Measured the spectrum width with power higher than 20dB below carrier.

### 5.2 DEVIATION FROM STANDARD

FCC Part15.225

### 5.3 TEST SETUP





### 5.4 TEST RESULTS

EUT :	Handheld Device	Model Name :	GT50VH2
Temperature :	26 °C	Relative Humidity :	54%
Pressure :	1020 hPa	Test Power :	DC 3.8V
Test Mode :	TX		

Test Channel	Frequency (MHz)	20 dBc Bandwidth (kHz)
CH01	13.56	250.7

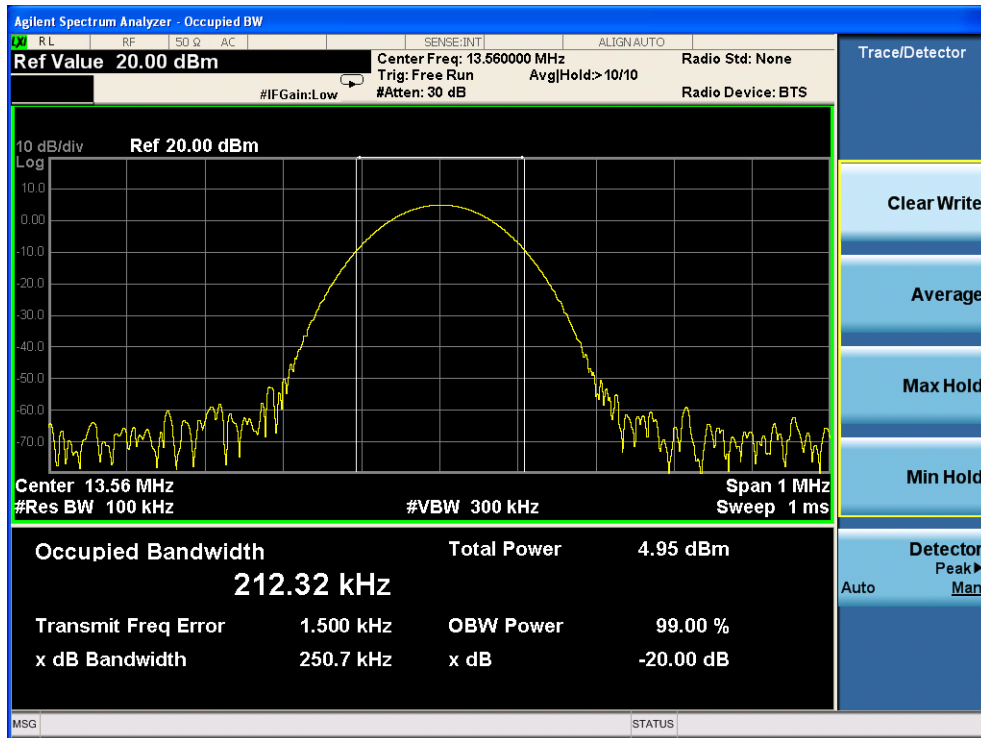

## 6. FREQUENCY TOLERANCE

### 6.1 Requirement:

Test Requirement: FCC Part15.225

Requirement:

Test Method: ANSI C63.4:2003

Requirement: The frequency tolerance of the carrier signal shall be maintained within +/- 0.01% of the operating frequency over a temperature variation of -20 degrees to +50 degrees C at normal supply voltage, and for a variation in the primary supply voltage from 85% to 115% of the rated supply voltage at a temperature of 20 degrees C. For battery operated equipment, the equipment tests shall be performed using a new battery.

### 6.2 Test Procedure

- 1.The EUT was placed on a turn table which is 0.8m above ground plane.
- 2.Set EUT as normal operation
- 3.Set SPA Center Frequency = fundamental frequency, RBW, VBW= 10kHz, Span =100kHz.
- 4.Set SPA Max hold. Mark peak.

**Test Result**

Power Supply	Temperature (°C)	Measured Frequency (MHz)	Frequency Error (MHz)	Result (ppm)	Part 15.225 Limit
DC 3.23V	-20	13.561009	0.001009	74.4100295	+/- 0.01%(100ppm)
	20	13.56101	0.00101	74.4837758	+/- 0.01%(100ppm)
	50	13.561014	0.001014	74.7787611	+/- 0.01%(100ppm)
DC 3.8V	-20	13.561012	0.001012	74.6312684	+/- 0.01%(100ppm)
	20	13.56101	0.00101	74.4837758	+/- 0.01%(100ppm)
	50	13.56101	0.00101	74.4837758	+/- 0.01%(100ppm)
DC 4.37V	-20	13.561103	0.001103	81.3421829	+/- 0.01%(100ppm)
	20	13.561011	0.001011	74.5575221	+/- 0.01%(100ppm)
	50	13.561007	0.001007	74.2625369	+/- 0.01%(100ppm)

END REPORT