		NAZWA DOKUMENTU/ DOCUMENT'S TITLE:	
		Instruction for SBO Range Tester NL 4	
NR DOKUMENTU/ DOCUMENT'S NO.:	WERSJA/VERSION:	DATA WYDANIA WERSJI/ RELEASE DATE OF VERSION:	STRONA/PAGE:
			1 of 18

INSTRUCTION

SBO Range Tester NL 4



SBO Hearing A/S
 Kongebakken 9
 DK-2765 Smørum
 Denmark

WŁAŚCICIEL – ZATWIERDZENIE WYDANIA: OWNER - APPROVAL :		AUTOR: AUTHOR:		RECENZENT: REVIEWER:	
WYDRUK NADZOROWANY PRZEZ: PRINT-OUT IS SUPERVISED BY:				DATA WYDRUKU/ DATE OF PRINT	2017-11-15

		NAZWA DOKUMENTU/ DOCUMENT'S TITLE:	
		Instruction for SBO Range Tester NL 4	
NR DOKUMENTU/ DOCUMENT'S NO.:	WERSJA/VERSION:	DATA WYDANIA WERSJI/ RELEASE DATE OF VERSION:	STRONA/PAGE:
			2 of 18

Table of contents:

1. Introduction	4
1.1. Warning notice	4
1.2. Manufacturer	4
1.3. Type Approval label	4
1.4. Technical characteristic	5
1.4.1. General information	5
1.4.2. Dimensions	5
1.4.3. Power supply	5
1.5. Copyright	5
1.6. Responsibility	6
2. Precautions	7
2.1. Symbols	7
2.2. Warning signs	7
2.2.1. Waste Electrical and Electronic Equipment (WEEE) Directive	7
2.3. General safety instruction	7
2.4. Environmental conditions	8
3. Device description	9
3.1. Functionality of the device	9
3.2. Front Panel	9
3.3. Working area	9
3.4. Operation manual	10
4. Maintenance	12
4.1. General maintenance activities	12
4.2. Faults and remedies	12
4.3. Calibration	12
4.4. Firmware update	12
5. Spare parts	13
6. List of appendix	14
6.1. Appendix 1. Mechanical drawing	14
6.2. Appendix 2. Declaration of conformity	14

WŁAŚCICIEL – ZATWIERDZENIE WYDANIA: OWNER - APPROVAL :		AUTOR: AUTHOR:		RECENZENT: REVIEWER:	
WYDRUK NADZOROWANY PRZEZ: PRINT-OUT IS SUPERVISED BY:				DATA WYDRUKU/ DATE OF PRINT	2017-11-15

NR DOKUMENTU/ DOCUMENT'S NO.:	WERSJA/VERSION:	DATA WYDANIA WERSJI/ RELEASE DATE OF VERSION:	STRONA/PAGE:
			3 of 18

6.3. Appendix 3. Pictures.....	14
Appendix 1. Mechanical drawing.....	15
Appendix 2. Declaration of conformity.....	16
Appendix 3. Pictures.....	17

WŁAŚCICIEL – ZATWIERDZENIE WYDANIA: OWNER - APPROVAL :		AUTOR: AUTHOR:		RECENZENT: REVIEWER:	
WYDRUK NADZOROWANY PRZEZ: PRINT-OUT IS SUPERVISED BY:				DATA WYDRUKU/ DATE OF PRINT	2017-11-15

		NAZWA DOKUMENTU/ DOCUMENT'S TITLE:	
		Instruction for SBO Range Tester NL 4	
NR DOKUMENTU/ DOCUMENT'S NO.:	WERSJA/VERSION:	DATA WYDANIA WERSJI/ RELEASE DATE OF VERSION:	STRONA/PAGE:
			4 of 18

1. Introduction

1.1. Warning notice

This manual informs the operator about the safety conditions (and daily maintenance) of SBO Range Tester NL 4.

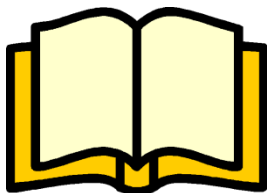

Read this manual carefully before using SBO Range Tester NL 4 or doing any operation on it. Operation and daily maintenance have to be done according to following instruction.

1.2. Manufacturer

Name and full address of the manufacturer
SBO Hearing A/S
Kongebakken 9
DK-2765 Smørum
Denmark

1.3. Type Approval label

Equipment is identified as a SBO Range Tester NL 4.

SBO Range Tester NL 4



ID: 2ACAH-RTBNL4
IC: 11936A-RTBNL4

Item no: 182631

Serial No. 12345678

Made in Poland

Figure 1. Type Approval label of the SBO Range Tester NL 4

NOTICE:

WŁAŚCICIEL – ZATWIERDZENIE WYDANIA: OWNER - APPROVAL :		AUTOR: AUTHOR:		RECENZENT: REVIEWER:	
WYDRUK NADZOROWANY PRZEZ: PRINT-OUT IS SUPERVISED BY:				DATA WYDRUKU/ DATE OF PRINT	2017-11-15

		NAZWA DOKUMENTU/ DOCUMENT'S TITLE:	
		Instruction for SBO Range Tester NL 4	
NR DOKUMENTU/ DOCUMENT'S NO.:	WERSJA/VERSION:	DATA WYDANIA WERSJI/ RELEASE DATE OF VERSION:	STRONA/PAGE:
			5 of 18

This device complies with Part 15 of the FCC Rules and with RSS-210 and RSS-247 of Industry Canada.

Operation is subject to the following two conditions:

- (1) This device may not cause harmful interference, and
- (2) This device must accept any interference received, including interference that may cause undesired operation.

Changes or modifications made to this equipment not expressly approved by SBO Hearing A/S may void the FCC authorization to operate this equipment.

Le présent appareil est conforme aux CNR d'Industrie Canada applicables aux appareils radio exempts de licence. L'exploitation est autorisée aux deux conditions suivantes:

- (1) l'appareil ne doit pas produire de brouillage, et*
- (2) l'utilisateur de l'appareil doit accepter tout brouillage radioélectrique subi, même si le brouillage est susceptible d'en compromettre le fonctionnement.*

1.4. Technical characteristic

1.4.1. General information

- Name: SBO Range Tester NL 4
- Item no: 182631

1.4.2. Dimensions

- Length: 104.50 [mm]
- Width: 61.30 [mm]
- Height: 27.50 [mm]
- Weight: 100 [g]

1.4.3. Power supply

- 9V D.C battery with max. dimensions 48.5x26.5x17.5 mm (alkaline, zinc-carbon and nickel-metal hydride). Nominal voltage has to be in range 8.4 – 9.6 V D.C.

1.5. Copyright

Copyright © SBO Hearing A/S. All rights reserved.

This document is the property of SBO Hearing A/S (the part of William Demant Group) and may not be copied or communicated to a third party or used for any purpose other than that for which it is supplied without the express written consent of the William Demant Group.

WŁAŚCICIEL – ZATWIERDZENIE WYDANIA: OWNER - APPROVAL :		AUTOR: AUTHOR:		RECENZENT: REVIEWER:	
WYDRUK NADZOROWANY PRZEZ: PRINT-OUT IS SUPERVISED BY:				DATA WYDRUKU/ DATE OF PRINT	2017-11-15

		NAZWA DOKUMENTU/ DOCUMENT'S TITLE:	
		Instruction for SBO Range Tester NL 4	
NR DOKUMENTU/ DOCUMENT'S NO.:	WERSJA/VERSION:	DATA WYDANIA WERSJI/ RELEASE DATE OF VERSION:	STRONA/PAGE:
			6 of 18

1.6. Responsibility

The manufacturer of the SBO Range Tester NL 4 is not responsible for dangerous situation, accidents and damage causes by:

- Use the SBO Range Tester NL 4 for purposes other than those specified in the operating instruction.
- Modification of the device. This includes the use of other spare parts and software changes.
- Insufficient maintenance.

WŁAŚCICIEL – ZATWIERDZENIE WYDANIA: OWNER - APPROVAL :		AUTOR: AUTHOR:		RECENZENT: REVIEWER:	
WYDRUK NADZOROWANY PRZEZ: PRINT-OUT IS SUPERVISED BY:				DATA WYDRUKU/ DATE OF PRINT	2017-11-15

DGS 		NAZWA DOKUMENTU/ DOCUMENT'S TITLE:	
		Instruction for SBO Range Tester NL 4	
NR DOKUMENTU/ DOCUMENT'S NO.:	WERSJA/VERSION:	DATA WYDANIA WERSJI/ RELEASE DATE OF VERSION:	STRONA/PAGE:
			7 of 18

2. Precautions

2.1. Symbols



Warning: A warning indicates a potential for hardware damage, loss of data, personal injury, or death if instructions are not followed.

2.2. Warning signs

2.2.1. Waste Electrical and Electronic Equipment (WEEE) Directive

In the European Union, this label indicates that this product should not be disposed of with household waste. It should be deposited at an appropriate facility to enable recovery and recycling.

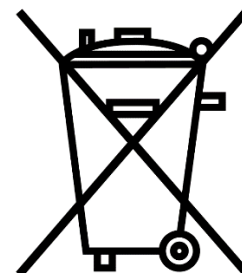

2.3. General safety instruction

SBO Range Tester NL 4 meets the essential safety and health requirements of the European Union. This means that the device can be operated and maintained safely when all safety measures are adhered to. Dangerous situations may occur due to negligence or recklessness of the user.



To avoid any device damaged, do not attempt to remove cover or touch the inside of the box. Only exception is the battery cover in a case of replacing battery. Only trained personnel can make repairs of the SBO Range Tester NL 4.



Use your equipment in accordance with environmental condition requirements.

WŁAŚCICIEL – ZATWIERDZENIE WYDANIA: OWNER - APPROVAL :		AUTOR: AUTHOR:		RECENZENT: REVIEWER:	
WYDRUK NADZOROWANY PRZEZ: PRINT-OUT IS SUPERVISED BY:				DATA WYDRUKU/ DATE OF PRINT	2017-11-15

DGS 		NAZWA DOKUMENTU/ DOCUMENT'S TITLE:	
		Instruction for SBO Range Tester NL 4	
NR DOKUMENTU/ DOCUMENT'S NO.:	WERSJA/VERSION:	DATA WYDANIA WERSJI/ RELEASE DATE OF VERSION:	STRONA/PAGE:
			8 of 18



Use your equipment in accordance with operating instruction.



Do not make any unauthorized modification of the device.



Any repairs or part replacing need to be performed by manufacturer of the SBO Range Tester NL 4.

2.4. Environmental conditions

User of the device have to follow below condition during operation:

- Distance from metal objects have to be more than 15 cm (from SBO Range Tester NL 4 on all sides, from device under test on all sides and from a straight line between the SBO Range Tester NL 4 on all sides).
- Magnetic field measured on test station have to be less than 0.4 mT.
- No powered instruments with nEARlink 4 within the range 35 cm from working area.
- No powered equipment (computers, powers supplies, mobiles etc.) in working area.
- Temp. range: 10 - 27 °C.

WŁAŚCICIEL – ZATWIERDZENIE WYDANIA: OWNER - APPROVAL :		AUTOR: AUTHOR:		RECENZENT: REVIEWER:	
WYDRUK NADZOROWANY PRZEZ: PRINT-OUT IS SUPERVISED BY:				DATA WYDRUKU/ DATE OF PRINT	2017-11-15

		NAZWA DOKUMENTU/ DOCUMENT'S TITLE:	
		Instruction for SBO Range Tester NL 4	
NR DOKUMENTU/ DOCUMENT'S NO.:	WERSJA/VERSION:	DATA WYDANIA WERSJI/ RELEASE DATE OF VERSION:	STRONA/PAGE:
			9 of 18

3. Device description

3.1. Functionality of the device

Main function of the SBO Range Tester NL 4 is to verify the nEARlink 4 communication performance on a certain range for custom devices with nEARlink 4.

3.2. Front Panel

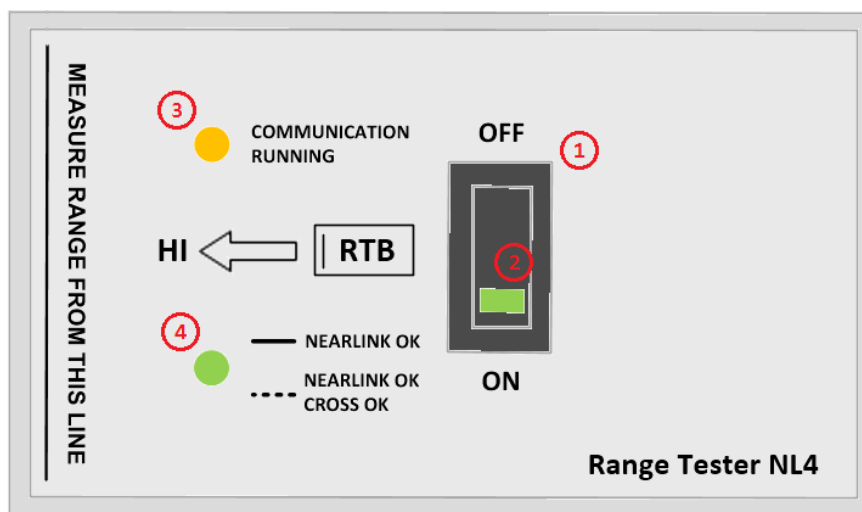



Figure 2. Front panel of the SBO Range Tester NL 4

1. Main switch
2. Green LED – power on indication
3. Yellow LED – received packets indication
4. Green LED – pass/fail indication

3.3. Working area

SBO Range Tester NL 4 is designed to be use in well-defined area (see picture below).

WŁAŚCICIEL – ZATWIERDZENIE WYDANIA: OWNER - APPROVAL :		AUTOR: AUTHOR:		RECENZENT: REVIEWER:	
WYDRUK NADZOROWANY PRZEZ: PRINT-OUT IS SUPERVISED BY:				DATA WYDRUKU/ DATE OF PRINT	2017-11-15

		NAZWA DOKUMENTU/ DOCUMENT'S TITLE:	
		Instruction for SBO Range Tester NL 4	
NR DOKUMENTU/ DOCUMENT'S NO.:	WERSJA/VERSION:	DATA WYDANIA WERSJI/ RELEASE DATE OF VERSION:	STRONA/PAGE:
			10 of 18

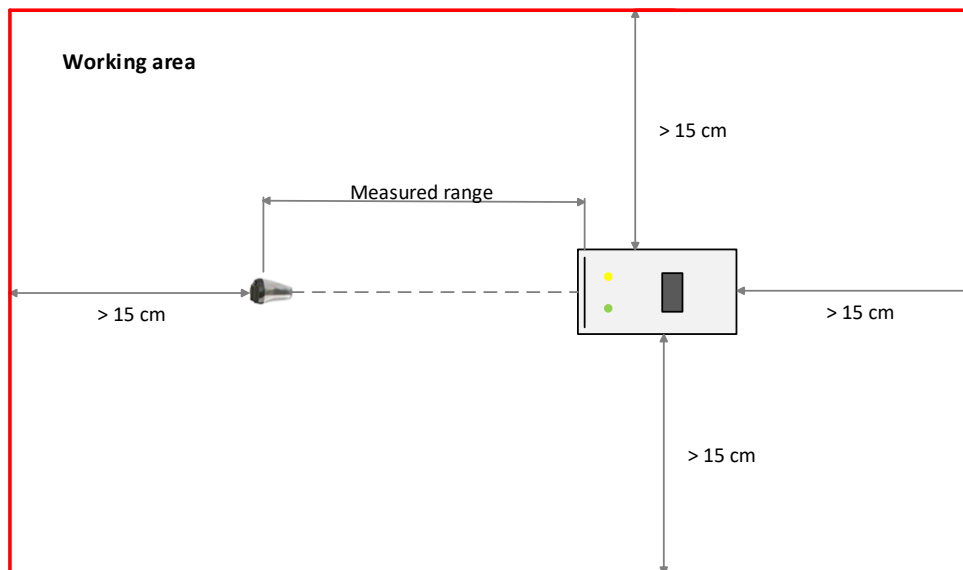

Figure 3. Working area.

Custom instrument must be oriented in such a way that the surface of the battery door is perpendicular to the line connecting hearing instrument and the tester. The inlet must be on the tester side. Range is measured between the line on the Range Tester (MEASURE RANGE FROM THIS LINE) and the line on the hearing instrument where faceplate and the shell are connected together. All environmental conditions must be fulfilled.

SBO Range Tester NL 4 is able to work just with one Hearing Instrument at the time. Please ensure that only one Hearing Instrument is within the range. It means that other powered Hearing Instruments have to be placed more than 35 cm from working area.

3.4. Operation manual

To check communication performance with Range Tester NL4 you should go thru below steps:

- Place Hearing Instrument in a fixed position in a working area. Hearing Instrument has to be powered with a new battery (according to HI specifications).
- Place SBO Range Tester NL 4 about 35 cm from Hearing Instrument according to Figure 3. Working area.
- Turn on Tester with main switch ①.
- Check if power indication LED ② lights. If not, battery has to be replaced with new one.
- During start green LED ④ will light up for about 5s. After that Tester is ready to be used.
- Move Tester towards the Hearing Instrument and find distance where yellow LED ③ will start blinking. Yellow LED is turned on for a short whenever Hearing Instrument is able to report back successful reception of a packet.

WŁAŚCICIEL – ZATWIERDZENIE WYDANIA: OWNER - APPROVAL :		AUTOR: AUTHOR:		RECENZENT: REVIEWER:	
WYDRUK NADZOROWANY PRZEZ: PRINT-OUT IS SUPERVISED BY:				DATA WYDRUKU/ DATE OF PRINT	2017-11-15

		NAZWA DOKUMENTU/ DOCUMENT'S TITLE:	
		Instruction for SBO Range Tester NL 4	
NR DOKUMENTU/ DOCUMENT'S NO.:	WERSJA/VERSION:	DATA WYDANIA WERSJI/ RELEASE DATE OF VERSION:	STRONA/PAGE:
			11 of 18

- Move Tester closer to the Hearing Instrument and find distance where green LED ④ lights up. Steady light means that the Tester received information that 45 out of 50 packets were received correctly by the Hearing Instrument, which is enough for instruments without streaming audio. Fast green LED ④ blinking means that the Tester received information that the Hearing Instrument received 100 000 bits without any error (with 1 second delay), which is mandatory for instruments with audio streaming.

WŁAŚCICIEL – ZATWIERDZENIE WYDANIA: OWNER - APPROVAL :		AUTOR: AUTHOR:		RECENZENT: REVIEWER:	
WYDRUK NADZOROWANY PRZEZ: PRINT-OUT IS SUPERVISED BY:				DATA WYDRUKU/ DATE OF PRINT	2017-11-15

		NAZWA DOKUMENTU/ DOCUMENT'S TITLE:	
		Instruction for SBO Range Tester NL 4	
NR DOKUMENTU/ DOCUMENT'S NO.:	WERSJA/VERSION:	DATA WYDANIA WERSJI/ RELEASE DATE OF VERSION:	STRONA/PAGE:
			12 of 18

4. Maintenance

4.1. General maintenance activities

Area	Maintenance activity
Battery	To ensure proper operation of the Tester, indication on the rocker switch ② has to lights whenever switch is in ON position. Replace battery with new one if above condition is not fulfilled.
Working area	Before starting work, make sure that there are no metal parts in the work area. Before starting work, make sure that there are no magnets in the work area. Check if there are no powered Hearing Instruments within the range 35 cm from working area. Check if there are no powered equipment in the working area.

4.2. Faults and remedies

Fault	Cause	Remedies
Tester is not turning ON	Low battery voltage	Replace battery with new one
	Rocker switch is broken	Replace rocker switch with new one. Can be done only by personnel trained by manufacturer.
	Battery connector is broken	Replace battery connector. Can be done only by personnel trained by manufacturer.

4.3. Calibration

Calibration of transmit power and trimming of the resonance tank are performed during production of the Tester.

Manufacturer is able to verify Tester by using golden samples. It is recommended to verify Testers once per year.

In case of failed verification, the Tester should be sent back to the manufacturer for re-calibration.

4.4. Firmware update

Any firmware update should be done by the manufacturer.

WŁAŚCICIEL – ZATWIERDZENIE WYDANIA: OWNER - APPROVAL :		AUTOR: AUTHOR:		RECENZENT: REVIEWER:	
WYDRUK NADZOROWANY PRZEZ: PRINT-OUT IS SUPERVISED BY:				DATA WYDRUKU/ DATE OF PRINT	2017-11-15

		NAZWA DOKUMENTU/ DOCUMENT'S TITLE:	
		Instruction for SBO Range Tester NL 4	
NR DOKUMENTU/ DOCUMENT'S NO.:	WERSJA/VERSION:	DATA WYDANIA WERSJI/ RELEASE DATE OF VERSION:	STRONA/PAGE:
			13 of 18

5. Spare parts

	Name	Type	Manufacturer
1	Rocker switch	DM64J72S205Q6	C & K
2	Battery connector	440005P	MULTICOMP

WŁAŚCICIEL – ZATWIERDZENIE WYDANIA: OWNER - APPROVAL :		AUTOR: AUTHOR:		RECENZENT: REVIEWER:	
WYDRUK NADZOROWANY PRZEZ: PRINT-OUT IS SUPERVISED BY:				DATA WYDRUKU/ DATE OF PRINT	2017-11-15

		NAZWA DOKUMENTU/ DOCUMENT'S TITLE:	
		Instruction for SBO Range Tester NL 4	
NR DOKUMENTU/ DOCUMENT'S NO.:	WERSJA/VERSION:	DATA WYDANIA WERSJI/ RELEASE DATE OF VERSION:	STRONA/PAGE:
			14 of 18

6. List of appendix.

- 6.1. **Appendix 1. Mechanical drawing.**
- 6.2. **Appendix 2. Declaration of conformity.**
- 6.3. **Appendix 3. Pictures.**

WŁAŚCICIEL – ZATWIERDZENIE WYDANIA: OWNER - APPROVAL :		AUTOR: AUTHOR:		RECENZENT: REVIEWER:	
WYDRUK NADZOROWANY PRZEZ: PRINT-OUT IS SUPERVISED BY:				DATA WYDRUKU/ DATE OF PRINT	2017-11-15

		NAZWA DOKUMENTU/ DOCUMENT'S TITLE:	
		Instruction for SBO Range Tester NL 4	
NR DOKUMENTU/ DOCUMENT'S NO.:	WERSJA/VERSION:	DATA WYDANIA WERSJI/ RELEASE DATE OF VERSION:	STRONA/PAGE:
			15 of 18

Appendix 1. Mechanical drawing.

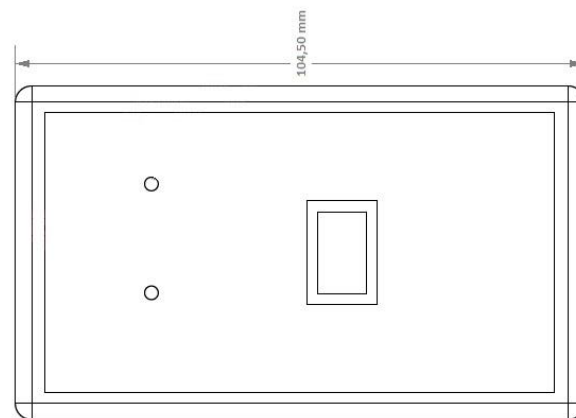
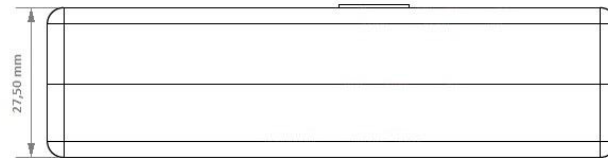
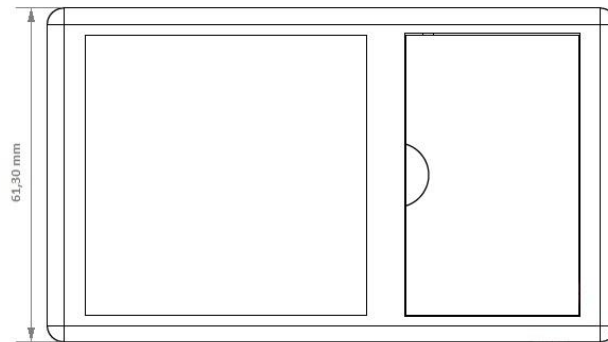

WŁAŚCICIEL – ZATWIERDZENIE WYDANIA: OWNER - APPROVAL :		AUTOR: AUTHOR:		RECENZENT: REVIEWER:	
WYDRUK NADZOROWANY PRZEZ: PRINT-OUT IS SUPERVISED BY:				DATA WYDRUKU/ DATE OF PRINT	2017-11-15

		NAZWA DOKUMENTU/ DOCUMENT'S TITLE:	
		Instruction for SBO Range Tester NL 4	
NR DOKUMENTU/ DOCUMENT'S NO.:	WERSJA/VERSION:	DATA WYDANIA WERSJI/ RELEASE DATE OF VERSION:	STRONA/PAGE:
			16 of 18

Appendix 2. Declaration of conformity.

DECLARATION OF CONFORMITY (RED)

(Manufacturer's Declaration)

Manufacturer: SBO Hearing A/S,
Kongebakken 9,
DK-2765 Smørum,
Denmark
Telephone: +45 39 17 71 00

The Manufacturer declares under its sole responsibility that the following device:

Family: Nearlink Range Tester
Model: SBO Range Tester NL 4

is in conformity with the essential requirements and other relevant requirements of the following Directives and Regulations:

Radio Equipment Directive 2014/53/EU and council recommendation 1999/519/EC on the limitation of exposure of the general public to electromagnetic fields (0 Hz to 300 GHz).

Standard(s) Applied in Full:

Article 3.1a: EN 62479:2010
IEC 62368-1: 2014 (2.Edition) and Cor. 1: 2015, and
EN 62368-1: 2014/AC: 2015/A11: 2017

Article 3.1b: EN 301 489 -1 v.2.2.0 (Draft)
ETSI EN 301 489-3 v.2.1.1 (Final Draft)

Article 3.2: EN 300 330 v.2.1.1 (Final Draft)

Testing Organization:

CTC advanced GmbH, Untertürkheimer Strasse 6–10, 66117 Saarbrücken, Germany

Signed in Smørum, 2017-11-03.



Ole Myrtue, on behalf of SBO Hearing A/S
Regulatory Affairs Officer



SBO Hearing A/S

WŁAŚCICIEL – ZATWIERDZENIE WYDANIA: OWNER - APPROVAL :		AUTOR: AUTHOR:		RECENZENT: REVIEWER:	
WYDRUK NADZOROWANY PRZEZ: PRINT-OUT IS SUPERVISED BY:				DATA WYDRUKU/ DATE OF PRINT	2017-11-15

DGS ✓		NAZWA DOKUMENTU/ DOCUMENT'S TITLE:	
		Instruction for SBO Range Tester NL 4	
NR DOKUMENTU/ DOCUMENT'S NO.:	WERSJA/VERSION:	DATA WYDANIA WERSJI/ RELEASE DATE OF VERSION:	STRONA/PAGE:
			17 of 18

Appendix 3. Pictures

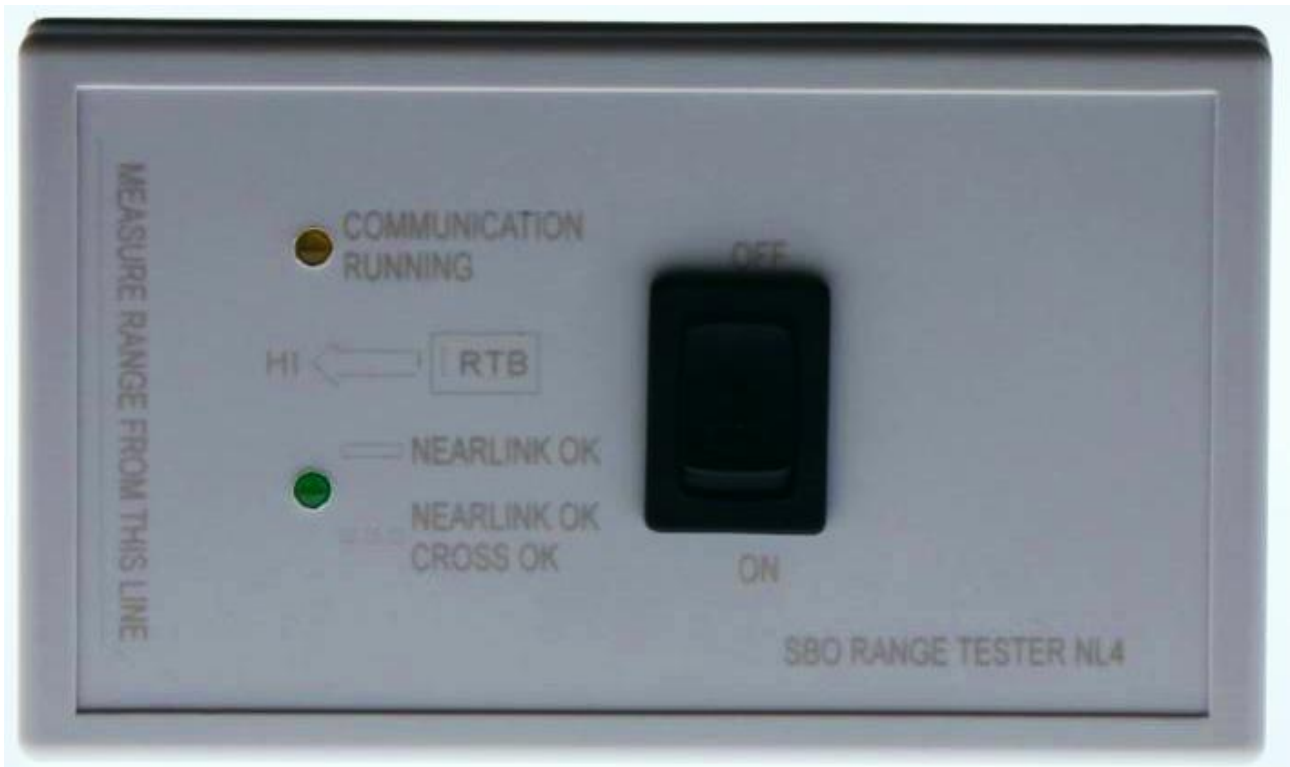

Figure 4. Front panel with main switch and LEDs.

WŁAŚCICIEL - ZATWIERDZENIE WYDANIA: OWNER - APPROVAL :		AUTOR: AUTHOR:		RECENZENT: REVIEWER:	
WYDRUK NADZOROWANY PRZEZ: PRINT-OUT IS SUPERVISED BY:				DATA WYDRUKU/ DATE OF PRINT	2017-11-15

		NAZWA DOKUMENTU/ DOCUMENT'S TITLE:	
		Instruction for SBO Range Tester NL 4	
NR DOKUMENTU/ DOCUMENT'S NO.:	WERSJA/VERSION:	DATA WYDANIA WERSJI/ RELEASE DATE OF VERSION:	STRONA/PAGE:
			18 of 18



Figure 5. Back side with Type Approval label and battery compartment.

WŁAŚCICIEL – ZATWIERDZENIE WYDANIA: OWNER - APPROVAL :		AUTOR: AUTHOR:		RECENZENT: REVIEWER:	
WYDRUK NADZOROWANY PRZEZ: PRINT-OUT IS SUPERVISED BY:				DATA WYDRUKU/ DATE OF PRINT	2017-11-15