

FCC Radio Test Report

FCC ID: 2AC9W-CMC191

This report concerns (check one): Original Grant Class II Change

Project No. : 1407C152
Equipment : **ESL READER**
Model Name : CMC191
Applicant : FUTAIHUA INDUSTRIAL (SHENZHEN) CO.,LTD.
Address : B District, Foxconn Technology Park, Guanlan Town,
Baonan, Shenzhen, Guangdong, China

Date of Receipt : Jul. 21, 2014
Date of Test : Jul. 21, 2014~ Sep. 03, 2014
Issued Date : Sep. 05, 2014
Tested by : BTL Inc.

Testing Engineer : David Mao
(David Mao)

Technical Manager : Leo Hung
(Leo Hung)

Authorized Signatory : Steven Lu
(Steven Lu)

B T L I N C .

No.3, Jinshagang 1st Road, Shixia, Dalang Town, Dongguan, China.
TEL: +86-769-8318-3000 FAX: +86-769-8319-6000

Declaration

BTL represents to the client that testing is done in accordance with standard procedures as applicable and that test instruments used has been calibrated with the standards traceable to National Measurement Laboratory (**NML**) of **R.O.C.**, or National Institute of Standards and Technology (**NIST**) of **U.S.A.**

BTL's reports apply only to the specific samples tested under conditions. It is manufacture's responsibility to ensure that additional production units of this model are manufactured with the identical electrical and mechanical components. **BTL** shall have no liability for any declarations, inferences or generalizations drawn by the client or others from **BTL** issued reports.

BTL's reports must not be used by the client to claim product endorsement by the authorities or any agency of the Government.

This report is the confidential property of the client. As a mutual protection to the clients, the public and **BTL-self**, extracts from the test report shall not be reproduced except in full with **BTL's** authorized written approval.

BTL's laboratory quality assurance procedures are in compliance with the **ISO Guide 17025** requirements, and accredited by the conformity assessment authorities listed in this test report.

Limitation

For the use of the authority's logo is limited unless the Test Standard(s)/Scope(s)/Item(s) mentioned in this test report is (are) included in the conformity assessment authorities acceptance respective.

Table of Contents	Page
1 . CERTIFICATION	6
2 . SUMMARY OF TEST RESULTS	7
2.1 TEST FACILITY	8
2.2 MEASUREMENT UNCERTAINTY	8
3 . GENERAL INFORMATION	9
3.1 GENERAL DESCRIPTION OF EUT	9
3.2 DESCRIPTION OF TEST MODES	10
3.3 BLOCK DIAGRAM SHOWING THE CONFIGURATION OF SYSTEM TESTED	11
3.4 DESCRIPTION OF SUPPORT UNITS	11
4 . EMC EMISSION TEST	12
4.1 CONDUCTED EMISSION MEASUREMENT	12
4.1.1 POWER LINE CONDUCTED EMISSION	12
4.1.2 TEST PROCEDURE	12
4.1.3 DEVIATION FROM TEST STANDARD	12
4.1.4 TEST SETUP	13
4.1.5 EUT OPERATING CONDITIONS	13
4.1.6 EUT TEST CONDITIONS	13
4.1.7 TEST RESULTS	13
4.2 RADIATED EMISSION MEASUREMENT	14
4.2.1 RADIATED EMISSION LIMITS	14
4.2.2 TEST PROCEDURE	15
4.2.3 DEVIATION FROM TEST STANDARD	15
4.2.4 TEST SETUP	16
4.2.5 EUT OPERATING CONDITIONS	17
4.2.6 EUT TEST CONDITIONS	17
4.2.7 TEST RESULTS (BELOW 30MHz)	17
4.2.8 TEST RESULTS (BETWEEN 30 – 1000 MHz)	17
4.2.9 TEST RESULTS (ABOVE 1000 MHz)	18
5 . BANDWIDTH TEST	19
5.1 TEST PROCEDURE	19
5.2 DEVIATION FROM STANDARD	19
5.3 TEST SETUP	19
5.4 EUT OPERATION CONDITIONS	19
5.5 EUT TEST CONDITIONS	19
5.6 TEST RESULTS	19
6 . ANTENNA CONDUCTED SPURIOUS EMISSION	20
6.1 APPLIED PROCEDURES / LIMIT	20

Table of Contents	Page
6.2 TEST PROCEDURE	20
6.3 DEVIATION FROM STANDARD	20
6.4 TEST SETUP	20
6.5 EUT OPERATION CONDITIONS	21
6.6 EUT TEST CONDITIONS	21
6.7 TEST RESULTS	21
7 . MEASUREMENT INSTRUMENTS LIST AND SETTING	22
8 . EUT TEST PHOTO	23
ATTACHMENT A - CONDUCTED EMISSION	27
ATTACHMENT B - RADIATED EMISSION (9KHZ to 30MHZ)	30
ATTACHMENT C - RADIATED EMISSION (30MHZ TO 1000MHZ)	32
ATTACHMENT D - RADIATED EMISSION (ABOVE 1000MHZ)	39
ATTACHMENT E - BANDWIDTH	52
ATTACHMENT F - ANTENNA CONDUCTED SPURIOUS EMISSION	55

REPORT ISSUED HISTORY

Issued No.	Description	Issued Date
BTL-FCCP-1-1407C152	Original Issue.	Sep. 05, 2014

1. CERTIFICATION

Equipment : ESL READER
Brand Name : CMCID
Model Name : CMC191
Applicant : FUTAIHUA INDUSTRIAL (SHENZHEN) CO.,LTD.
Manufacturer : FUTAIHUA INDUSTRIAL (SHENZHEN) CO.,LTD.
Address : B District, Foxconn Technology Park, Guanlan Town, Baoan, Shenzhen,
GuangDong, China
Factory : FUTAIHUA INDUSTRIAL (SHENZHEN) CO.,LTD.
Address : B District, Foxconn Technology Park, Guanlan Town, Baoan, Shenzhen,
GuangDong, China
Date of Test : Jul, 21. 2014~ Sep, 03. 2014
Test Sample : Engineering Sample
Standard(s) : FCC Part15, Subpart C(15.249)/ ANSI C63.4-2009
RSS-GEN Issue 3, Dec 2010

The above equipment has been tested and found compliance with the requirement of the relative standards by BTL Inc.

The test data, data evaluation, and equipment configuration contained in our test report (Ref No. BTL-FCCP-1-1407C152) were obtained utilizing the test procedures, test instruments, test sites that has been accredited by the Authority of TAF according to the ISO-17025 quality assessment standard and technical standard(s).

2. SUMMARY OF TEST RESULTS

Test procedures according to the technical standard(s):

FCC Part15, Subpart C (15.249)			
StandardSection	Test Item	Judgment	Remark
15.207	Conducted Emission	PASS	
15.209 15.249	Radiated Spurious Emission	PASS	

NOTE:

(1) "N/A" denotes test is not applicable in this test report.

2.1 TEST FACILITY

The test facilities used to collect the test data in this report is **DG-C02/DG-CB03** at the location of No.3,Jinshagang 1st Road, ShiXia, Dalang Town,Dong Guan, China.523792

BTL's test firm number for FCC: 319330

2.2 MEASUREMENT UNCERTAINTY

Where relevant, the following measurement uncertainty levels have been estimated for tests performed on the EUT as specified in CISPR 16-4-2:

The reported uncertainty of measurement $y \pm U$, where expanded uncertainty U is based on a standard uncertainty multiplied by a coverage factor of $k=2$, providing a level of confidence of approximately 95 %.

A. Conducted Measurement :

Test Site	Method	Measurement Frequency Range	U , (dB)	NOTE
DG-C02	CISPR	150 KHz ~ 30MHz	3.4	

B. Radiated Measurement :

Test Site	Method	Measurement Frequency Range	Ant. H / V	U,(dB)	NOTE
DG-CB03	CISPR	9KHz~30MHz	V	3.79	
		9KHz~30MHz	H	3.57	
		30MHz ~ 200MHz	V	3.82	
		30MHz ~ 200MHz	H	3.60	
		200MHz ~ 1,000MHz	V	3.86	
		200MHz ~ 1,000MHz	H	3.94	
		1GHz~18GHz	V	3.12	
		1GHz~18GHz	H	3.68	
		18GHz~40GHz	V	4.15	
		18GHz~40GHz	H	4.14	

3. GENERAL INFORMATION

3.1 GENERAL DESCRIPTION OF EUT

Equipment	ESL READER	
Brand Name	CMCID	
Model Name	CMC191	
Model Difference	N/A	
Product Description	Operation Frequency	2401~2445 MHz
	Modulation Technology	GFSK(2Mbps)
	Data rate	
	Field Strength	84.98dBuV/m(AV Max)
Power Source	DC Voltage supplied from AC/DC adapter.(SUPPORT UNITS)	
Power Rating	I/P 120-240V 50/60Hz 500mAh O/P:120V/1000mAh	
Connecting I/O Port(s)	Please refer to the User's Manual	

Note:

1. For a more detailed features description, please refer to the manufacturer's specifications or the User's Manual.

2.

Channel	Frequency (MHz)
01	2401
02	2408
03	2414
04	2421
05	2427
06	2433
07	2439
08	2445

3. Table for Filed Antenna

Ant.	Manufacturer	Model Name	Antenna Type	Connector	Gain (dBi)	Note
1	N/A	N/A	Printed	N/A	5.0	-

3.2 DESCRIPTION OF TEST MODES

To investigate the maximum EMI emission characteristics generated from EUT, the test system was pre-scanning tested based on the consideration of following EUT operation mode or test configuration mode which possible have effect on EMI emission level. Each of these EUT operation mode(s) or test configuration mode(s) mentioned above was evaluated respectively.

Pretest Mode	Description
Mode 1	TX Low Channel
Mode 2	TX Middle Channel
Mode 3	TX High Channel

For Radiated Test	
Final Test Mode	Description
Mode 1	TX Low Channel
Mode 2	TX Middle Channel
Mode 3	TX High Channel

Note:

(1) The measurements are performed at the high, middle, low available channels.

3.3 BLOCK DIAGRAM SHOWING THE CONFIGURATION OF SYSTEM TESTED

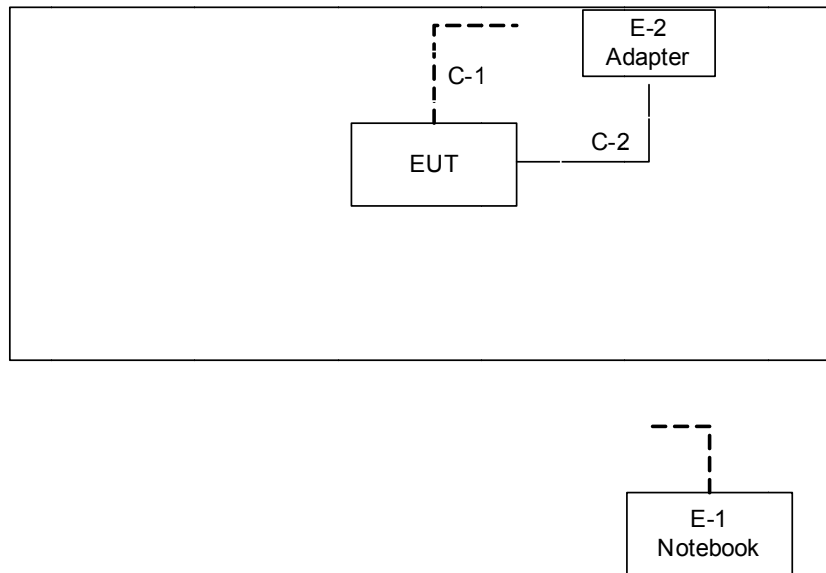

3.4 DESCRIPTION OF SUPPORT UNITS

The EUT has been tested as an independent unit together with other necessary accessories or support units. The following support units or accessories were used to form a representative test configuration during the tests.

Item	Equipment	Mfr/Brand	Model/Type No.	FCC ID	Series No.	Note
E-1	Notebook	DELL	INSPIRON 1420	DOC	NA	
E-2	Adapter	NA	NA	NA	NA	

Item	Shielded Type	Ferrite Core	Length	Note
C-1	NO	NO	10m	RJ45
C-2	NO	NO	2m	USB Cable

4. EMC EMISSION TEST

4.1 CONDUCTED EMISSION MEASUREMENT

4.1.1 POWER LINE CONDUCTED EMISSION (FREQUENCY RANGE 150KHZ-30MHZ)

Frequency of Emission (MHz)	Conducted Limit (dB μ V)	
	Quasi-peak	Average
0.15 -0.5	66 to 56*	56 to 46*
0.50 -5.0	56	46
5.0 -30.0	60	50

Note:

- (1) The limit of " * " decreases with the logarithm of the frequency

The following table is the setting of the receiver

Receiver Parameters	Setting
Attenuation	10 dB
Start Frequency	0.15 MHz
Stop Frequency	30 MHz
IF Bandwidth	9 kHz

4.1.2 TEST PROCEDURE

- a. The EUT was placed 0.8 meters from the horizontal ground plane with EUT being connected to the power mains through a line impedance stabilization network (LISN). All other support equipments powered from additional LISN(s). The LISN provide 50 Ohm/ 50uH of coupling impedance for the measuring instrument.
- b. Interconnecting cables that hang closer than 40 cm to the ground plane shall be folded back and forth in the center forming a bundle 30 to 40 cm long.
- c. I/O cables that are not connected to a peripheral shall be bundled in the center. The end of the cable may be terminated, if required, using the correct terminating impedance. The overall length shall not exceed 1 m.
- d. LISN at least 80 cm from nearest part of EUT chassis.
- e. For the actual test configuration, please refer to the related Item –EUT Test Photos.

4.1.3 DEVIATION FROM TEST STANDARD

No deviation

4.1.4 TEST SETUP

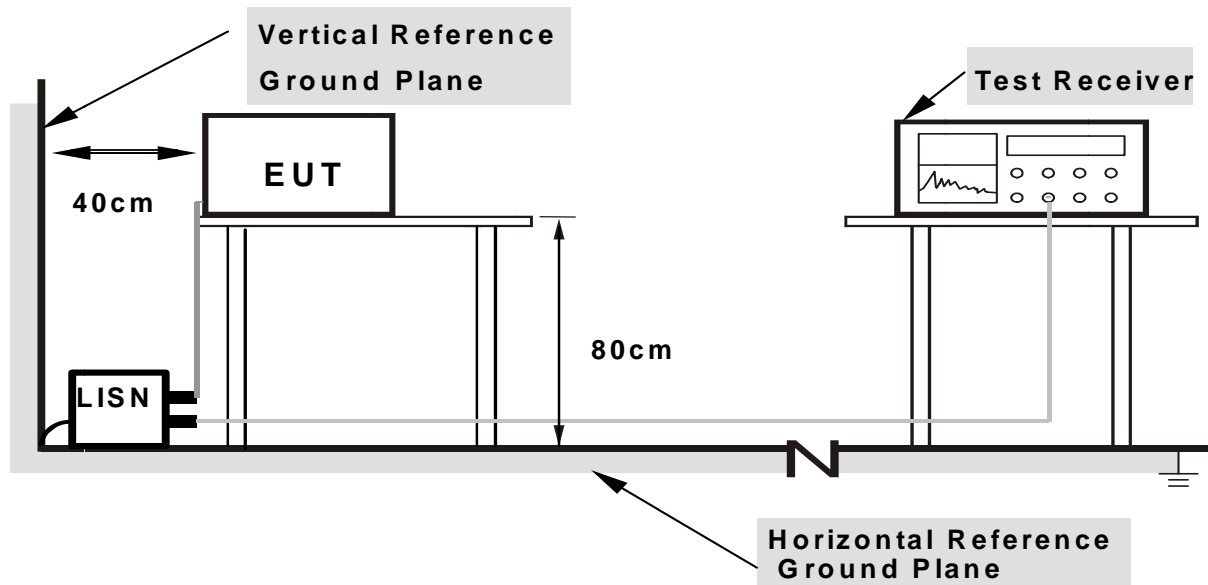

- Note: 1. Support units were connected to second LISN.**
2. Both of LISNs (AMN) are 80 cm from EUT and at least 80 cm from other units and other metal planes

4.1.5 EUT OPERATING CONDITIONS

The EUT was configured for testing in a typical fashion (as a customer would normally use it). The EUT has been programmed to continuously transmit during test. This operating condition was tested and used to collect the included data.
 The EUT was programmed to be in continuously transmitting mode.

4.1.6 EUT TEST CONDITIONS

Temperature: 25°C
 Relative Humidity: 55%
 Test Voltage: AC 120V/60Hz

4.1.7 TEST RESULTS

Please refer to the Attachment A.

Remark:

- (1) All readings are QP Mode value unless otherwise stated AVG in column of 'Note'. If the QP Mode Measured value compliance with the QP Limits and lower than AVG Limits, the EUT shall be deemed to meet both QP & AVG Limits and then only QP Mode was measured, but AVG Mode didn't perform in this case, a "*" marked in AVG Mode column of Interference Voltage Measured.
- (2) Measuring frequency range from 150KHz to 30MHz.

4.2 RADIATED EMISSION MEASUREMENT

4.2.1 RADIATED EMISSION LIMITS (FCC 15.209)

Frequencies (MHz)	Field Strength (micorvolts/meter)	Measurement Distance (meters)
0.009~0.490	2400/F(KHz)	300
0.490~1.705	24000/F(KHz)	30
1.705~30.0	30	30
30~88	100	3
88~216	150	3
216~960	200	3
960~1000	500	3

Harmonic emissions limits comply with below 54 dBuV/m at 3m. Other emissions radiated outside of the specified frequency bands, except for harmonics, shall be attenuated by at least 50 dB below the level of the fundamental or comply with the radiated emissions limits specified in section 15.209(a) limit in the table below has to be followed.

Note:

- (1) The tighter limit applies at the band edges.
- (2) Emission level (dBuV/m)=20log Emission level (uV/m).

LIMITS OF RADIATED EMISSION MEASUREMENT (FCC 15.209)

FREQUENCY (MHz)	(dBuV/m) (at 3m)	
	PEAK	AVERAGE
Above 1000	74	54

Notes:

- (1) The limit for radiated test was performed according to FCC PART 15C.
- (2) The tighter limit applies at the band edges.
- (3) Emission level (dBuV/m)=20log Emission level (uV/m).

LIMITS OF RADIATED EMISSION MEASUREMENT (FCC Part 15.249)

FCC Part15 (15.249) , Subpart C	
Limit	Frequency Range (MHz)
Field strength of fundamental 50000 μ V/m (94 dB μ V/m) @ 3 m	2400-2483.5
Field strength of harmonics 500 μ V/m (54 dB μ V/m) @ 3 m	Above 2483.5

Spectrum Parameter	Setting
Attenuation	Auto
Start Frequency	1000 MHz
Stop Frequency	10th carrier harmonic

Receiver Parameter	Setting
Attenuation	Auto
Start ~ Stop Frequency	9kHz~90kHz for PK/AVG detector
Start ~ Stop Frequency	90kHz~110kHz for QP detector
Start ~ Stop Frequency	110kHz~490kHz for PK/AVG detector
Start ~ Stop Frequency	490kHz~30MHz for QP detector
Start ~ Stop Frequency	30MHz~1000MHz for QP detector

4.2.2 TEST PROCEDURE

- a. The EUT was placed on the top of a rotating table 0.8 meters above the ground at a 3 meter semi-anechoic chamber. The table was rotated 360 degrees to determine the position of the highest radiation.(below 1GHz)
- b. The EUT was placed on the top of a rotating table 0.8 meters above the ground at a 3 meter semi-anechoic chamber. The table was rotated 360 degrees to determine the position of the highest radiation.(above 1GHz)
- c. The height of the equipment or of the substitution antenna shall be 0.8 m; the height of the test antenna shall vary between 1 m to 4 m. Both horizontal and vertical polarizations of the antenna are set to make the measurement.
- d. The initial step in collecting conducted emission data is a spectrum analyzer peak detector mode pre-scanning the measurement frequency range. Significant peaks are then marked and then AV detector mode re-measured.
- e. If the Peak Mode measured value compliance with and lower than Quasi Peak Mode Limit, the EUT shall be deemed to meet QP Limits and then no additional QP Mode measurement performed.
- f. For the actual test configuration, please refer to the related Item –EUT Test Photos.

4.2.3 DEVIATION FROM TEST STANDARD

No deviation

4.2.4 TEST SETUP

(A) Radiated Emission Test Set-Up Frequency Below 1 GHz

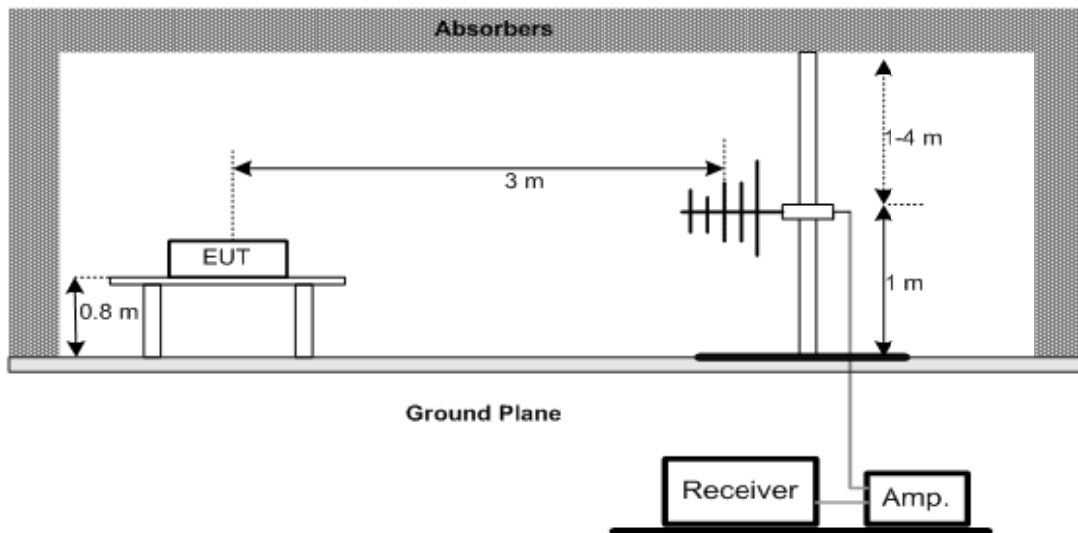

(B) Radiated Emission Test Set-Up Frequency Above 1 GHz

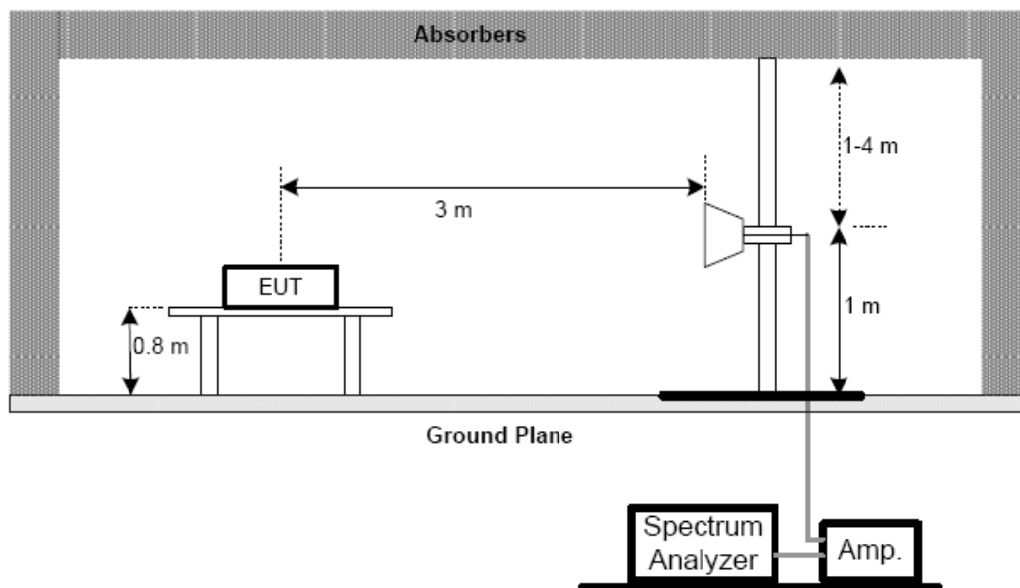

(C) For radiated emissions below 30MHz

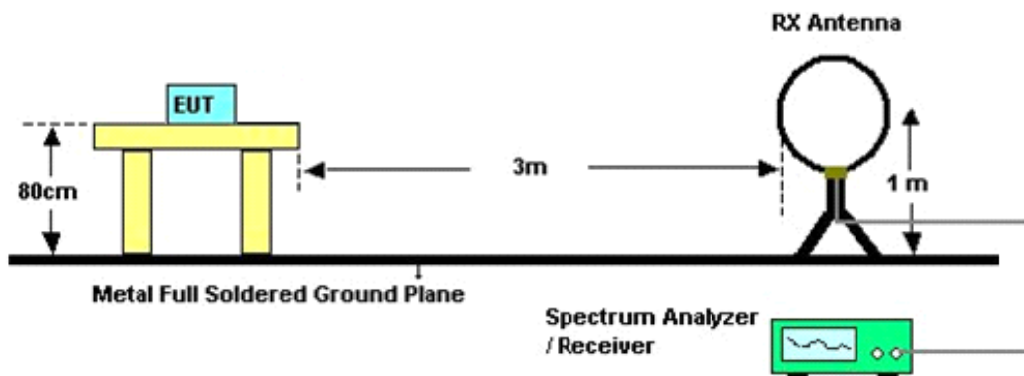

4.2.5 EUT OPERATING CONDITIONS

The EUT tested system was configured as the statements of 4.1.6 Unless otherwise a special operating condition is specified in the follows during the testing.

4.2.6 EUT TEST CONDITIONS

Temperature: 25°C

Relative Humidity: 55%

Test Voltage: AC 120V/60Hz

4.2.7 TEST RESULTS (BELOW 30MHz)

Please refer to the Attachment B.

Remark

- (1) The amplitude of spurious emissions which are attenuated by more than 20 dB below the permissible value has no need to be reported.
- (2) Distance extrapolation factor = $40 \log(\text{specific distance} / \text{test distance})$ (dB);.
- (3) Limit line = specific limits (dBuV) + distance extrapolation factor..

4.2.8 TEST RESULTS (BETWEEN 30 – 1000 MHz)

Please refer to the Attachment C

Remark :

- (1) All readings are Peak unless otherwise stated QP in column of 『Note』 . Peak denotes that the Peak reading compliance with the QP Limits and then QP Mode measurement didn't perform.
- (2) Measuring frequency range from 30MHz to 1000MHz or the 10th harmonic of highest fundamental frequency. "F" denotes fundamental frequency; "H" denotes spurious frequency. "E" denotes band edge frequency.
- (3) Radiated emissions measured in frequency range from 30 MHz to 1000 MHz were made with an instrument using Peak detector mode or QP detector mode of the emission .

4.2.9 TEST RESULTS (ABOVE 1000 MHz)

Please refer to the Attachment D

Remark :

- (1) All readings are Peak unless otherwise stated QP in column of 『Note』 . Peak denotes that the Peak reading compliance with the QP Limits and then QP Mode measurement didn't perform.
- (2) Radiated emissions measured in frequency range above 1000MHz were made with an instrument using Peak detector mode and AV detector mode of the emission .
- (3) Data of measurement within this frequency range shown “ * ” in the table above means the reading of emissions are attenuated more than 20dB below the permissible limits or the field strength is too small to be measured.
- (4) A preamp and high pass filter were used for this test in order to provide sufficient measurement sensitivity.
- (5) EUT Orthogonal Axis :
“X” - denotes Laid on Table ; “Y” - denotes Vertical Stand ; “Z” - denotes Side Stand
- (6) During the measurements above 1 GHz it is taken care of that the EUT is always within the 3 dB cone of radiation BW of the used antenna
- (7) The average value of fundamental frequency is:
Average = Peak value + 20log(Duty cycle) ,Final AV=PK-19.49

5. BANDWIDTH TEST

5.1 TEST PROCEDURE

- a. The EUT was directly connected to the spectrum analyzer and antenna output port as show in the block diagram below,
- b. Spectrum Setting: RBW= 100KHz, VBW=100KHz, Sweep time = Auto.

5.2 DEVIATION FROM STANDARD

No deviation.

5.3 TEST SETUP



5.4 EUT OPERATION CONDITIONS

The EUT tested system was configured as the statements of 4.1.6 Unless otherwise a special operating condition is specified in the follows during the testing.

5.5 EUT TEST CONDITIONS

Temperature: 25°C
Relative Humidity: 55%
Test Voltage: AC 120V/60Hz

5.6 TEST RESULTS

Please refer to the Attachment E

6. ANTENNA CONDUCTED SPURIOUS EMISSION

6.1 APPLIED PROCEDURES / LIMIT

In any 100 kHz bandwidth outside the frequency band in which the spread spectrum or digitally modulated intentional radiator is operating, the radio frequency power that is produced by the intentional radiator shall be at least 20 dB below that in the 100 kHz bandwidth within the band that contains the highest level of the desired power, based on either an RF conducted measurement, provided the transmitter demonstrates compliance with the peak conducted power limits.

6.2 TEST PROCEDURE

- a. The EUT was directly connected to the spectrum analyzer and antenna output port as show in the block diagram below,
- b. Spectrum Setting: RBW= 100KHz, VBW=100KHz, Sweep time = 10 ms.

6.3 DEVIATION FROM STANDARD

No deviation.

6.4 TEST SETUP



6.5 EUT OPERATION CONDITIONS

The EUT tested system was configured as the statements of 4.1.6 Unless otherwise a special operating condition is specified in the follows during the testing.

6.6 EUT TEST CONDITIONS

Temperature: 25°C

Relative Humidity: 55%

Test Voltage: AC 120V/60Hz

6.7 TEST RESULTS

Please refer to the Attachment F

7. MEASUREMENT INSTRUMENTS LIST AND SETTING

Conducted Emission Measurement					
Item	Kind of Equipment	Manufacturer	Type No.	Serial No.	Calibrated until
1	LISN	EMCO	3816/2	00052765	Mar. 29, 2015
2	LISN	R&S	ENV216	101447	Mar. 29, 2015
3	Test Cable	N/A	C_17	N/A	Mar. 14, 2015
4	EMI TEST RECEIVER	R&S	ESCS30	833364/017	Mar. 29, 2015
5	50Ω Terminator	SHX	TF2-3G-A	08122902	Mar. 29, 2015

Radiated Emission Measurement					
Item	Kind of Equipment	Manufacturer	Type No.	Serial No.	Calibrated until
1	Antenna	Schwarbeck	VULB9160	9160-3232	Mar. 29, 2015
2	Amplifier	HP	8447D	2944A09673	Mar. 29, 2015
3	Test Receiver	R&S	ESCI	100382	Mar. 29, 2015
4	Test Cable	N/A	C-01_CB03	N/A	Jul. 01, 2015
5	Antenna	ETS	3115	00075789	Mar. 29, 2015
6	Amplifier	Agilent	8449B	3008A02274	Mar. 29, 2015
7	Spectrum	Agilent	E4408B	US39240143	Nov. 09, 2014
8	Test Cable	HUBER+SUHNER	C-45	N/A	Jan. 14, 2015
9	Controller	CT	SC100	N/A	N/A
10	Horn Antenna	EMCO	3115	9605-4803	Mar. 29, 2015
11	Active Loop Antenna	R&S	HFH2-Z2	830749/020	Mar. 29, 2015
12	Broad-Band Horn Antenna	Schwarzbeck	BBHA 9170	9170319	Oct. 22, 2014

Bandwidth					
Item	Kind of Equipment	Manufacturer	Type No.	Serial No.	Calibrated until
1	Spectrum Analyzer	R&S	FSP 40	100185	Nov. 11, 2014

Remark: "N/A" denotes no model name, serial no. or calibration specified.
All calibration period of equipment list is one year.

8. EUT TEST PHOTO

Conducted Measurement Photos



Radiated Measurement Photos

9KHz to 30MHz



Radiated Measurement Photos

30MHz to 1000MHz

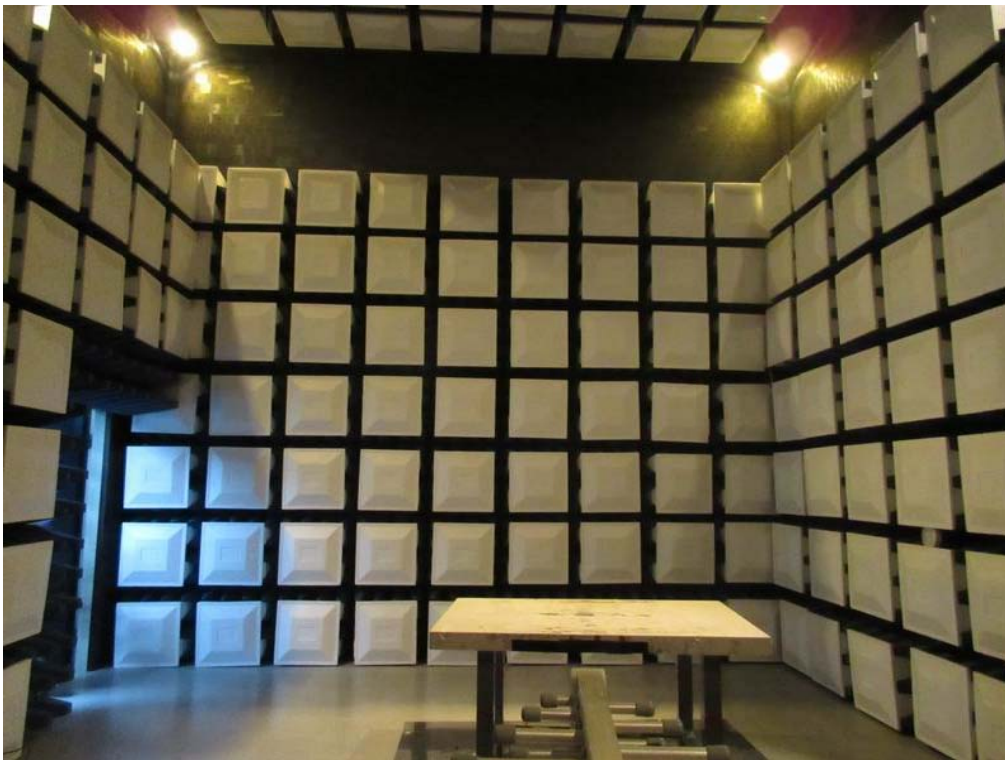

Radiated Measurement Photos

Above 1000MHz

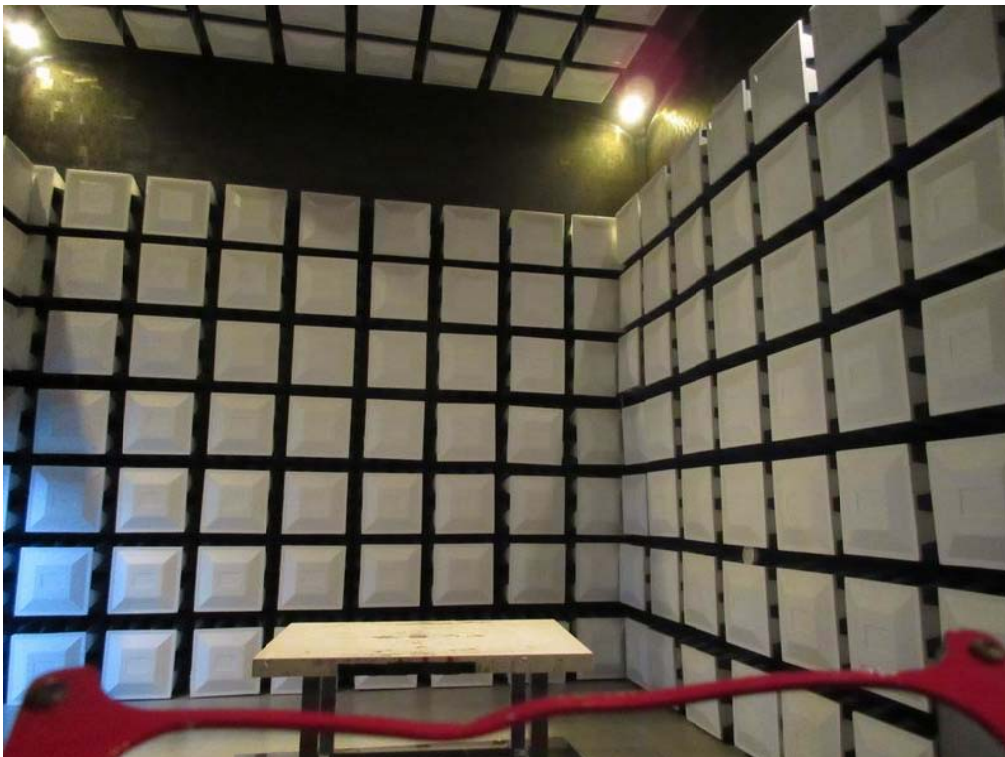

ATTACHMENT A - CONDUCTED EMISSION

Test Mode: TX Mode

Line

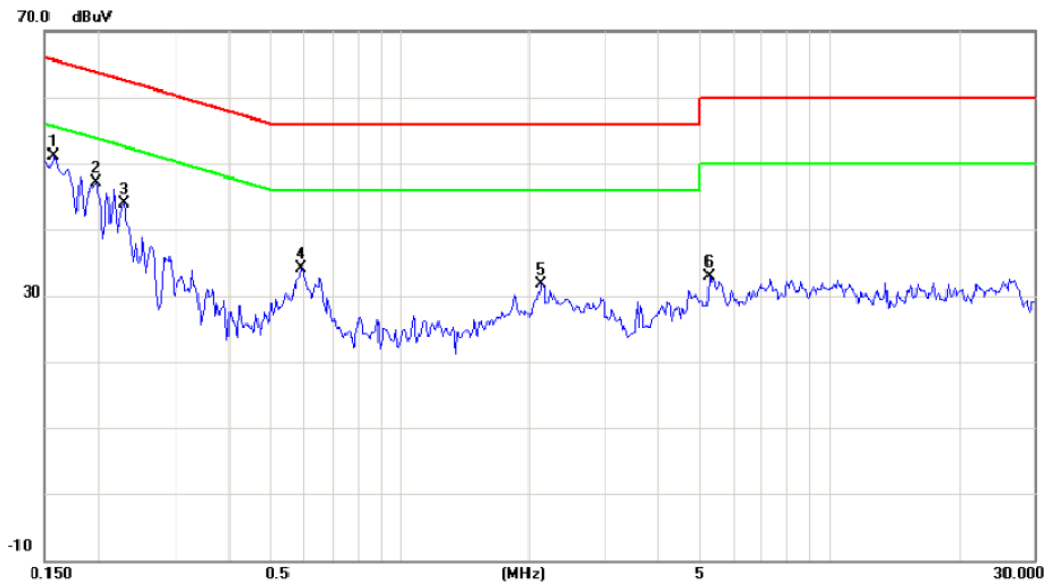

No. Mk.	Freq. MHz	Reading Level dBuV	Correct Factor dB	Measure- ment dBuV	Limit dBuV	Over dB	Detector	Comment
1 *	0.1577	41.55	9.52	51.07	65.58	-14.51	peak	
2	0.1968	37.53	9.54	47.07	63.74	-16.67	peak	
3	0.2280	34.28	9.55	43.83	62.52	-18.69	peak	
4	0.5914	24.49	9.66	34.15	56.00	-21.85	peak	
5	2.1381	22.06	9.72	31.78	56.00	-24.22	peak	
6	5.2656	22.95	9.89	32.84	60.00	-27.16	peak	

Test Mode: TX Mode

Neutral

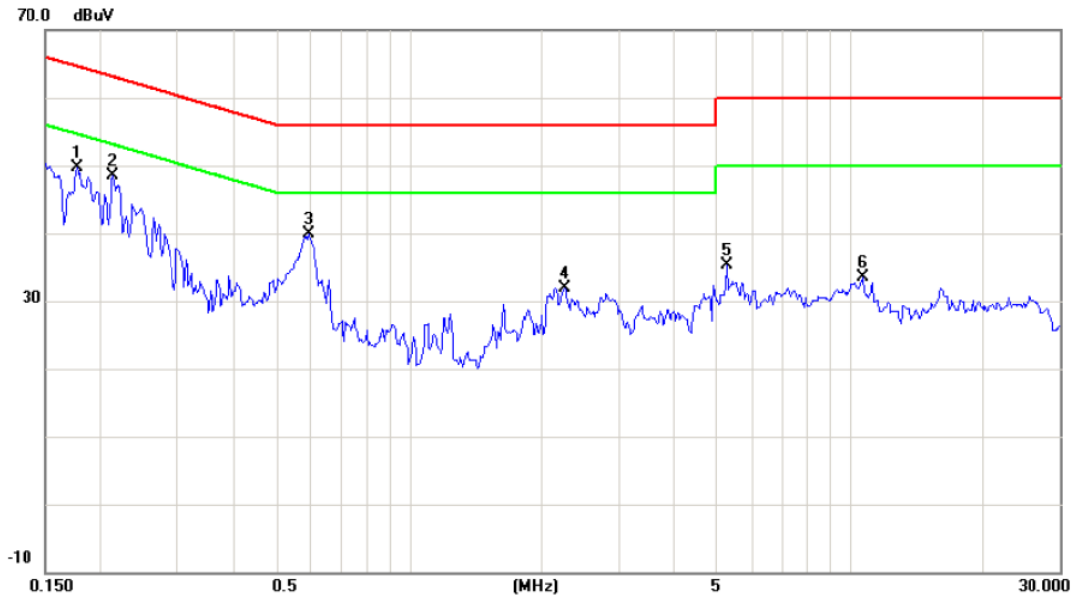

No.	Mk.	Freq. MHz	Reading Level dBuV	Correct Factor dB	Measure- ment dBuV	Limit dBuV	Over dB	Detector	Comment
1		0.1773	40.01	9.62	49.63	64.61	-14.98	peak	
2	*	0.2127	38.89	9.61	48.50	63.10	-14.60	peak	
3		0.5916	30.19	9.65	39.84	56.00	-16.16	peak	
4		2.2553	22.17	9.75	31.92	56.00	-24.08	peak	
5		5.2694	25.51	9.89	35.40	60.00	-24.60	peak	
6		10.6640	23.40	10.11	33.51	60.00	-26.49	peak	

ATTACHMENT B - RADIATED EMISSION (9KHZ to 30MHZ)

Test Mode:	TX Mode
------------	---------

Freq. (MHz)	Ant. 0°/90°	Reading(RA) (dBuV)	Corr.Factor(CF) (dB)	Measured(FS) (dBuV/m)	Limits(QP) (dBuV/m)	Margin (dB)	Note
0.0163	0°	14.41	24.53	38.94	103.36	-64.42	AVG
0.0163	0°	13.32	24.53	37.85	123.36	-85.51	PEAK
0.0324	0°	8.11	23.51	31.62	97.39	-65.77	AVG
0.0324	0°	6.25	23.51	29.76	117.39	-87.63	PEAK
0.0379	0°	5.56	23.17	28.73	96.03	-67.31	AVG
0.0379	0°	3.33	23.17	26.50	116.03	-89.54	PEAK
0.0466	0°	2.46	22.62	25.08	94.24	-69.16	AVG
0.0466	0°	0.89	22.62	23.51	114.24	-90.73	PEAK
2.0621	0°	30.27	19.46	49.73	69.54	-19.81	QP
3.3652	0°	21.25	18.94	40.19	69.54	-29.35	QP

Freq. (MHz)	Ant. 0°/90°	Reading(RA) (dBuV)	Corr.Factor(CF) (dB)	Measured(FS) (dBuV/m)	Limits(QP) (dBuV/m)	Margin (dB)	Note
0.0139	90°	14.25	24.30	38.55	124.74	-86.19	AVG
0.0139	90°	13.21	24.30	37.51	144.74	-107.23	PEAK
0.0326	90°	8.34	23.50	31.84	117.34	-85.50	AVG
0.0326	90°	6.51	23.50	30.01	137.34	-107.33	PEAK
0.0357	90°	5.48	23.31	28.79	116.55	-87.77	AVG
0.0357	90°	3.17	23.31	26.48	136.55	-110.08	PEAK
0.0673	90°	2.42	22.05	24.47	111.04	-86.57	AVG
0.0673	90°	0.95	22.05	23.00	131.04	-108.04	PEAK
2.0534	90°	30.23	19.47	49.70	69.54	-19.84	QP
3.2477	90°	21.42	18.92	40.34	69.54	-29.20	QP

Remark:

- (1) The amplitude of spurious emissions which are attenuated by more than 20 dB below the permissible value has no need to be reported.
- (2) Distance extrapolation factor = 40 log (specific distance / test distance) (dB);
- (3) Limit line = specific limits (dBuV) + distance extrapolation factor.

ATTACHMENT C - RADIATED EMISSION (30MHZ TO 1000MHZ)

Test Mode: TX Low Channel

Vertical

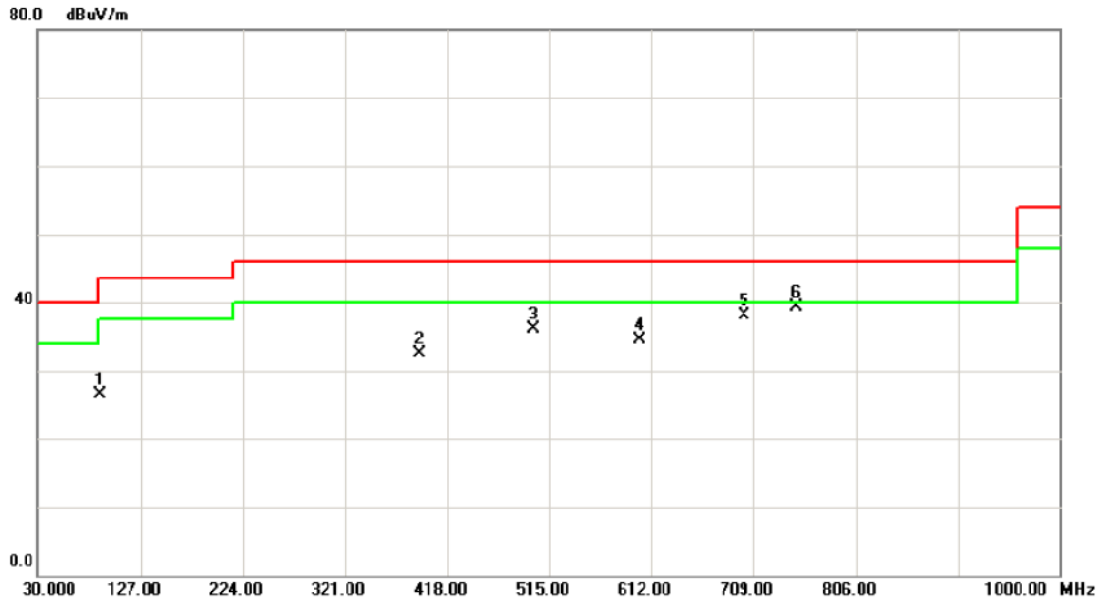

No. Mk.	Freq. MHz	Reading Level dBuV	Correct Factor dB	Measure- ment dBuV/m	Limit dBuV/m	Over dB	Detector	Comment
1	88.2000	41.92	-15.33	26.59	43.50	-16.91	peak	
2	390.8400	40.52	-8.08	32.44	46.00	-13.56	peak	
3	500.4500	43.63	-7.51	36.12	46.00	-9.88	peak	
4	600.3600	39.39	-4.96	34.43	46.00	-11.57	peak	
5	700.2700	38.94	-0.85	38.09	46.00	-7.91	peak	
6 *	749.7400	40.47	-1.12	39.35	46.00	-6.65	peak	

Test Mode: TX Low Channel

Horizontal

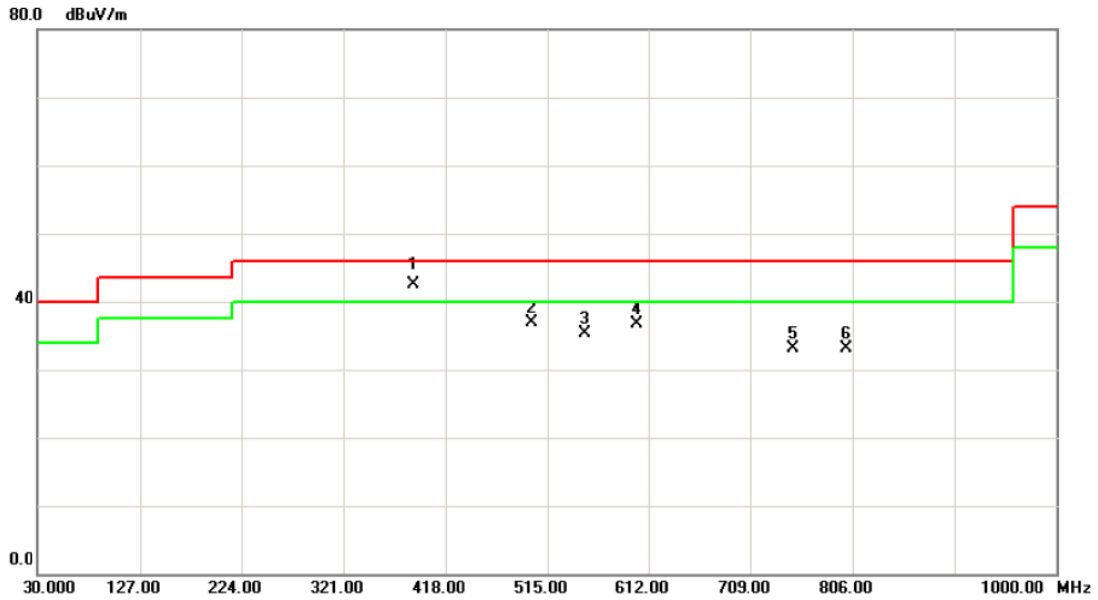

No.	Mk.	Freq. MHz	Reading Level dBuV	Correct Factor dB	Measure- ment dBuV/m	Limit dBuV/m	Over dB	Detector	Comment
1	*	387.9300	50.76	-8.22	42.54	46.00	-3.46	QP	
2		500.4500	44.47	-7.51	36.96	46.00	-9.04	peak	
3		549.9200	38.18	-2.88	35.30	46.00	-10.70	peak	
4		600.3600	41.57	-4.96	36.61	46.00	-9.39	peak	
5		749.7400	34.26	-1.12	33.14	46.00	-12.86	peak	
6		800.1800	31.34	1.83	33.17	46.00	-12.83	peak	

Test Mode: TX Middle Channel

Vertical

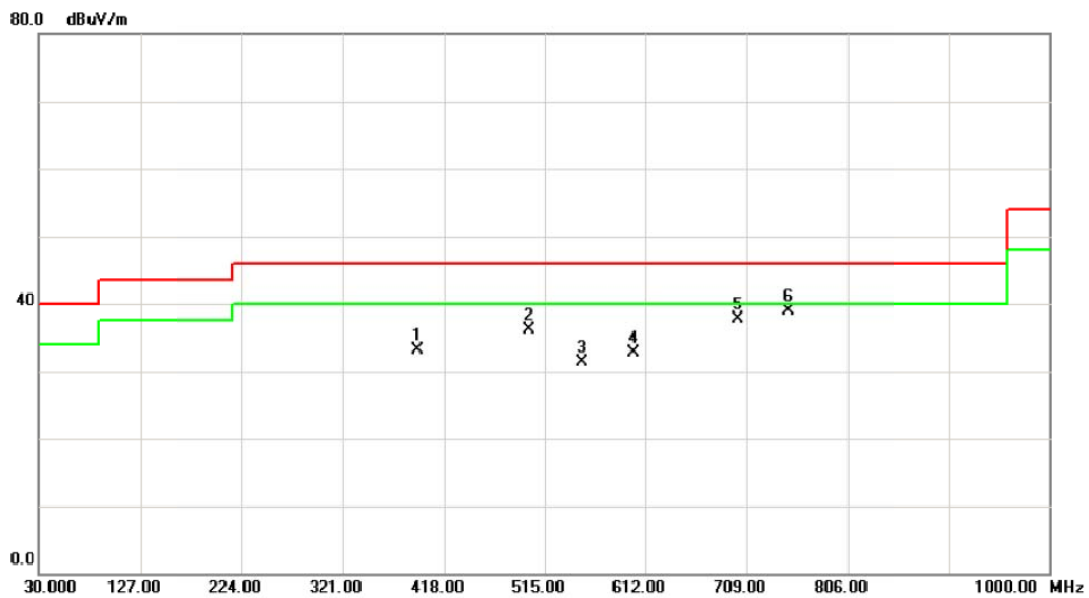

No. Mk.	Freq. MHz	Reading Level dBuV	Correct Factor dB	Measure- ment dBuV/m	Limit dBuV/m	Over dB	Detector	Comment
1	392.7800	41.06	-7.99	33.07	46.00	-12.93	peak	
2	500.4500	43.71	-7.51	36.20	46.00	-9.80	peak	
3	549.9200	34.22	-2.88	31.34	46.00	-14.66	peak	
4	600.3600	37.62	-4.96	32.66	46.00	-13.34	peak	
5	700.2700	38.58	-0.85	37.73	46.00	-8.27	peak	
6 *	749.7400	40.04	-1.12	38.92	46.00	-7.08	peak	

Test Mode: TX Middle Channel

Horizontal

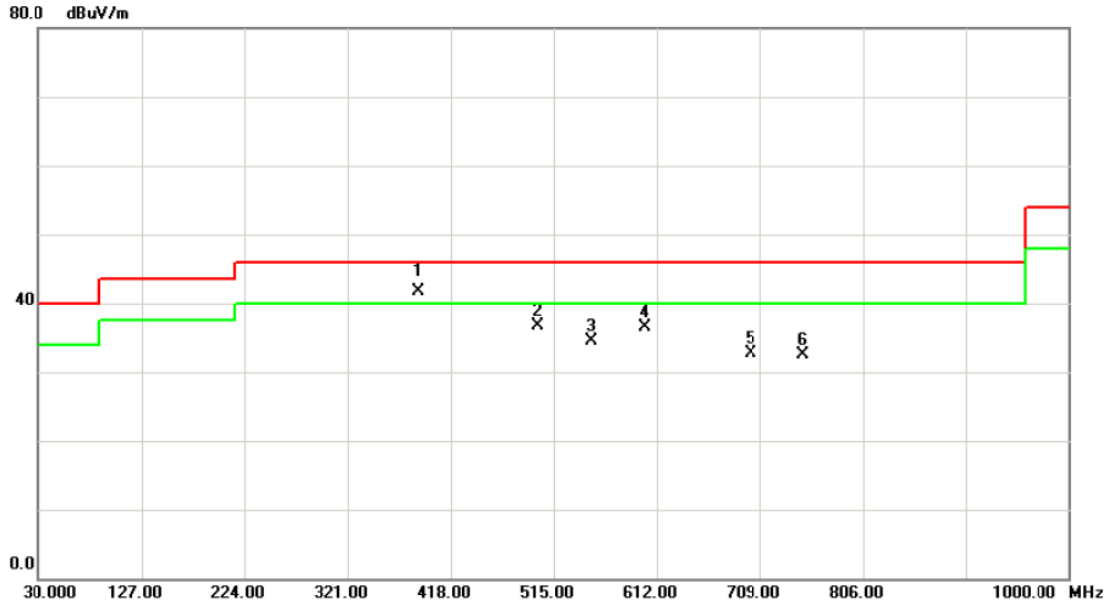

No.	Mk.	Freq. MHz	Reading Level dBuV	Correct Factor dB	Measure- ment dBuV/m	Limit dBuV/m	Over dB	Detector	Comment
1	*	386.9600	49.89	-8.27	41.62	46.00	-4.38	QP	
2		500.4500	44.30	-7.51	36.79	46.00	-9.21	peak	
3		549.9200	37.36	-2.88	34.48	46.00	-11.52	peak	
4		600.3600	41.50	-4.96	36.54	46.00	-9.46	peak	
5		700.2700	33.52	-0.85	32.67	46.00	-13.33	peak	
6		749.7400	33.71	-1.12	32.59	46.00	-13.41	peak	

Test Mode: TX High Channel

Vertical

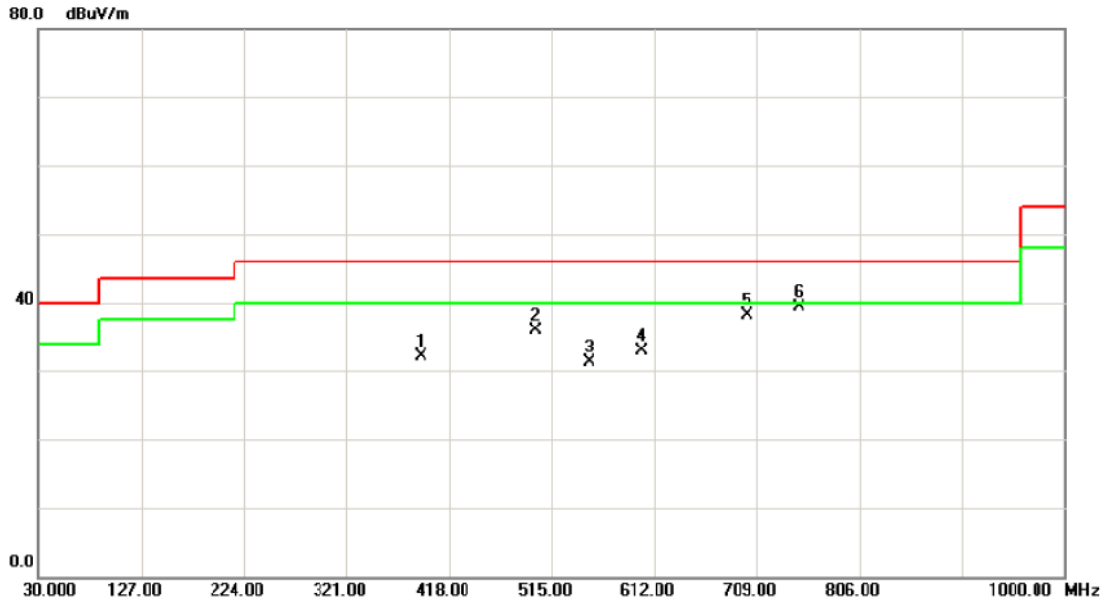

No.	Mk.	Freq. MHz	Reading Level dBuV	Correct Factor dB	Measure- ment dBuV/m	Limit dBuV/m	Over dB	Detector	Comment
1		390.8400	40.28	-8.08	32.20	46.00	-13.80	peak	
2		500.4500	43.34	-7.51	35.83	46.00	-10.17	peak	
3		549.9200	34.09	-2.88	31.21	46.00	-14.79	peak	
4		600.3600	37.88	-4.96	32.92	46.00	-13.08	peak	
5		700.2700	38.97	-0.85	38.12	46.00	-7.88	peak	
6	*	749.7400	40.39	-1.12	39.27	46.00	-6.73	peak	

Test Mode: TX High Channel

Horizontal

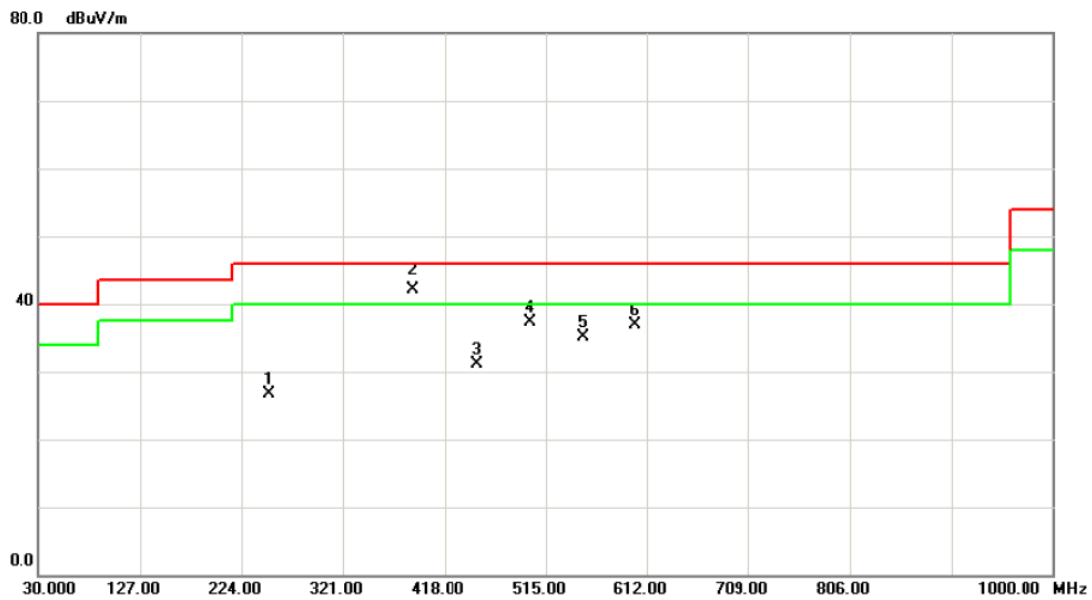

No. Mk.	Freq. MHz	Reading Level dBuV	Correct Factor dB	Measure- ment dBuV/m	Limit dBuV/m	Over dB	Detector	Comment
1	250.1900	40.06	-13.28	26.78	46.00	-19.22	peak	
2 *	387.9300	50.25	-8.22	42.03	46.00	-3.97	QP	
3	450.0100	36.87	-5.77	31.10	46.00	-14.90	peak	
4	500.4500	44.74	-7.51	37.23	46.00	-8.77	peak	
5	549.9200	37.97	-2.88	35.09	46.00	-10.91	peak	
6	600.3600	41.96	-4.96	37.00	46.00	-9.00	peak	

ATTACHMENT D - RADIATED EMISSION (ABOVE 1000MHZ)

Orthogonal Axis :	X
Test Mode :	TX Low Channel

Vertical

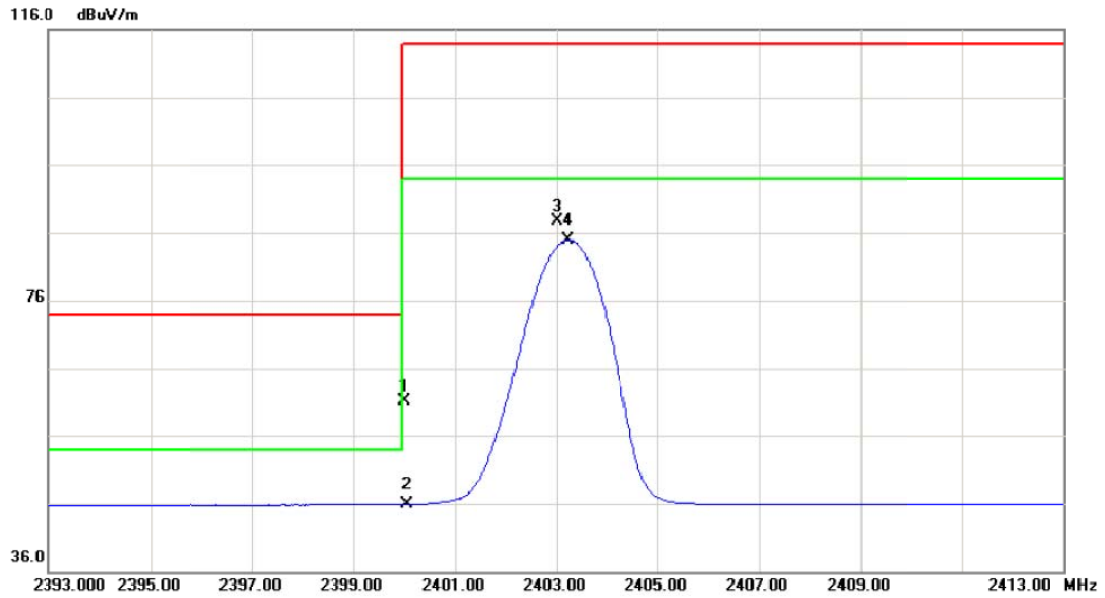

No.	Mk.	Freq. MHz	Reading Level dBuV	Correct Factor dB	Measure- ment dBuV/m	Limit dBuV/m	Over dB	Detector	Comment
1		2400.000	29.17	31.89	61.06	74.00	-12.94	peak	
2	*	2400.000	14.01	31.89	45.90	54.00	-8.10	AVG	
3		2403.000	55.72	31.89	87.61	114.00	-26.39	peak	
4		2403.220	53.09	31.89	84.98	94.00	-9.02	AVG	

Orthogonal Axis :	X
Test Mode :	TX Low Channel

Vertical

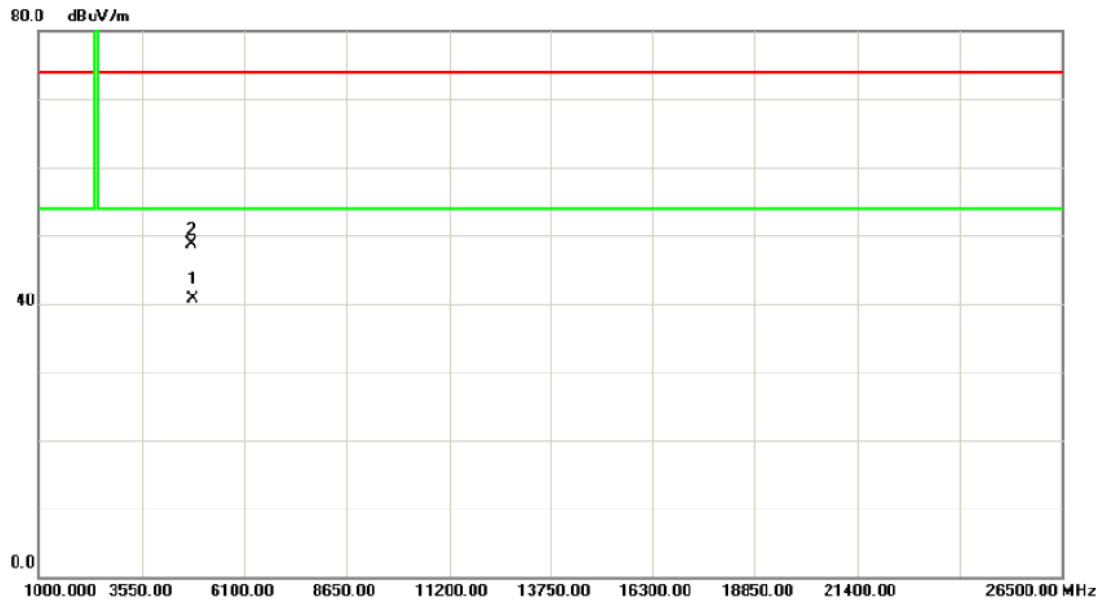

No.	Mk.	Freq. MHz	Reading Level dBuV	Correct Factor dB	Measure- ment dBuV/m	Limit dBuV/m	Over dB	Detector	Comment
1	*	4806.600	37.12	3.58	40.70	54.00	-13.30	AVG	
2		4806.650	45.10	3.58	48.68	74.00	-25.32	peak	

Orthogonal Axis :	X
Test Mode :	TX Low Channel

Horizontal

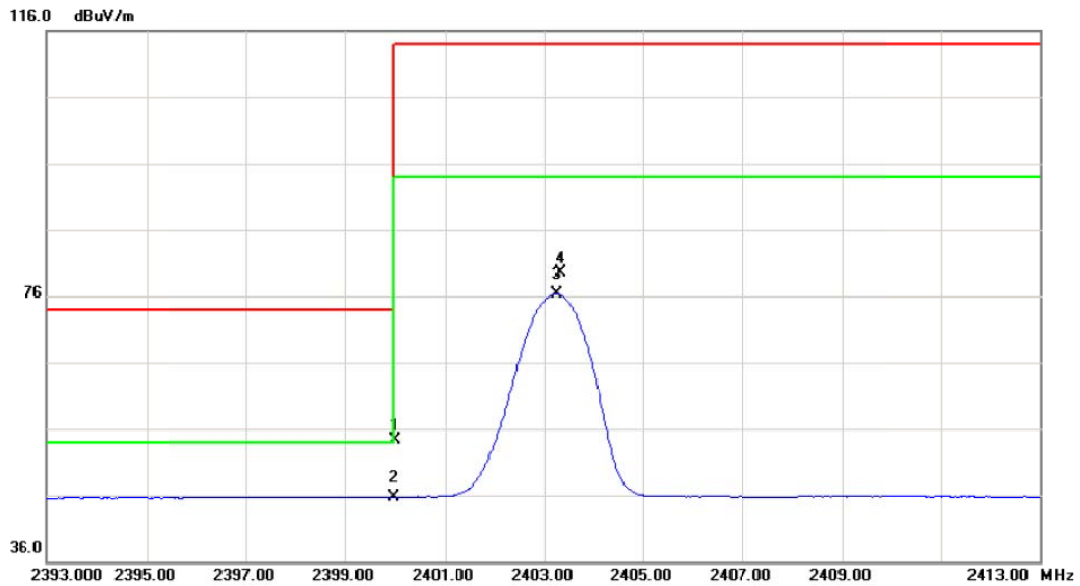

No. Mk.	Freq. MHz	Reading Level dBuV	Correct Factor dB	Measure- ment dBuV/m	Limit dBuV/m	Over dB	Detector	Comment
1	2400.000	22.49	31.89	54.38	74.00	-19.62	peak	
2 *	2400.000	13.82	31.89	45.71	54.00	-8.29	AVG	
3	2403.240	44.42	31.89	76.31	94.00	-17.69	AVG	
4	2403.340	47.62	31.89	79.51	114.0	-34.49	peak	

Orthogonal Axis :	X
Test Mode :	TX Low Channel

Horizontal

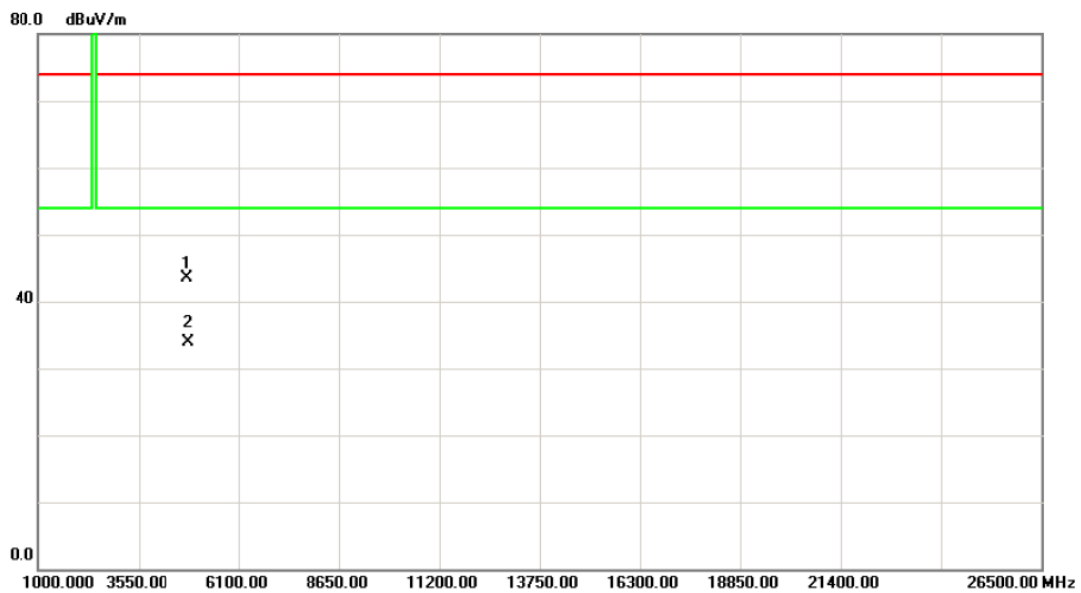

No. Mk.	Freq. MHz	Reading Level dBuV	Correct Factor dB	Measure- ment dBuV/m	Limit dBuV/m	Over dB	Detector	Comment
1	4806.650	39.88	3.58	43.46	74.00	-30.54	peak	
2 *	4806.650	30.28	3.58	33.86	54.00	-20.14	AVG	

Orthogonal Axis :	X
Test Mode :	TX Middle Channel

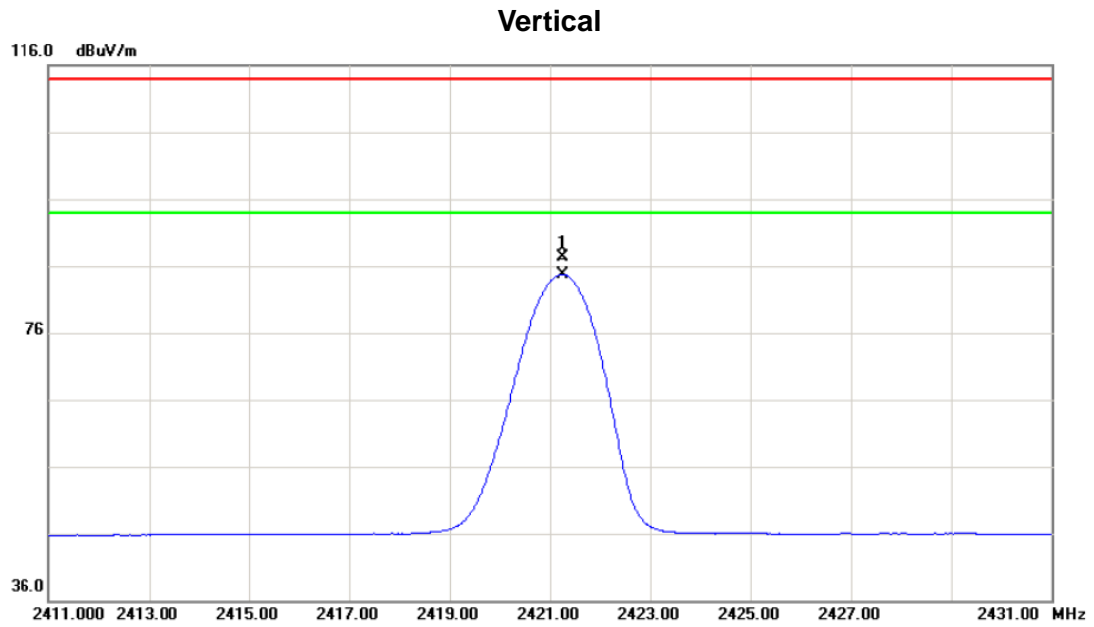

No.	Mk.	Freq. MHz	Reading Level dBuV	Correct Factor dB	Measure- ment dBuV/m	Limit dBuV/m	Over dB	Detector	Comment
1		2421.240	55.36	31.92	87.28	114.0	-26.72	peak	
2	*	2421.240	52.82	31.92	84.74	94.00	-9.26	AVG	

Orthogonal Axis :	X
Test Mode :	TX Middle Channel

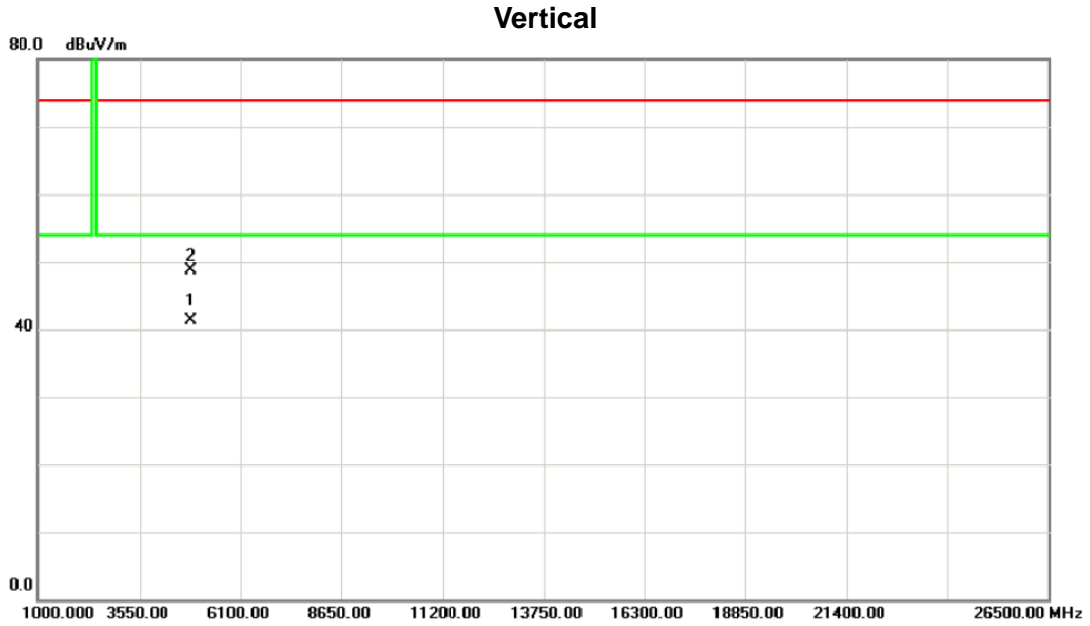

No. Mk.	Freq. MHz	Reading Level dBuV	Correct Factor dB	Measure- ment dBuV/m	Limit dBuV/m	Over dB	Detector	Comment
1 *	4842.600	37.62	3.66	41.28	54.00	-12.72	AVG	
2	4842.600	45.14	3.66	48.80	74.00	-25.20	peak	

Orthogonal Axis :	X
Test Mode :	TX Middle Channel

Horizontal

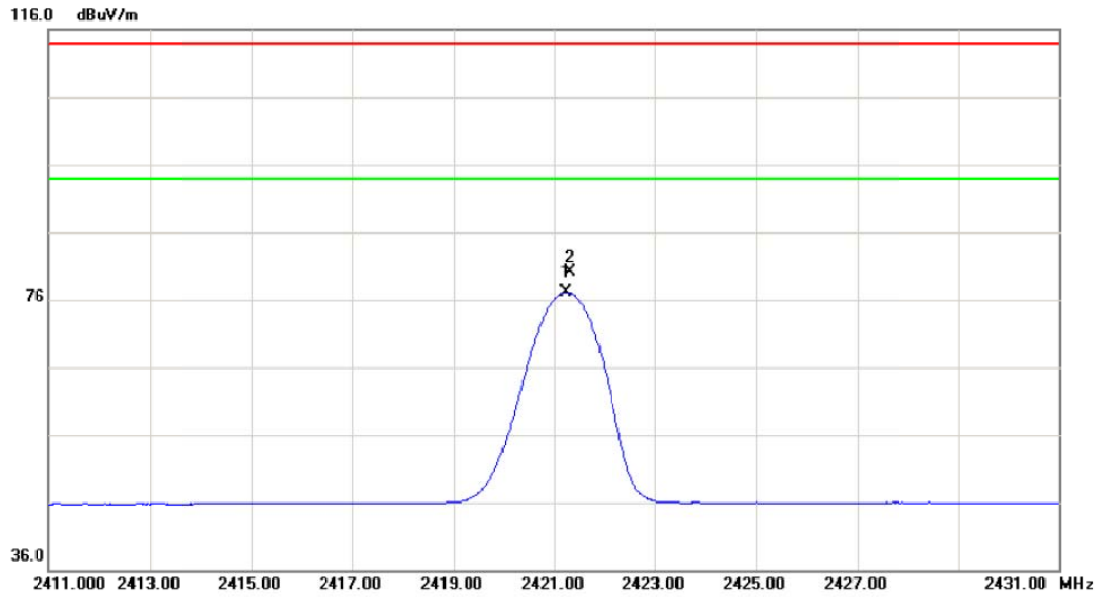

No.	Mk.	Freq.	Reading Level	Correct Factor	Measurement	Limit	Over	Detector	Comment
		MHz	dBuV	dB	dBuV/m	dBuV/m	dB		
1	*	2421.220	45.19	31.92	77.11	94.00	-16.89	AVG	
2		2421.300	48.19	31.92	80.11	114.00	-33.89	peak	

Orthogonal Axis :	X
Test Mode :	TX Middle Channel

Horizontal

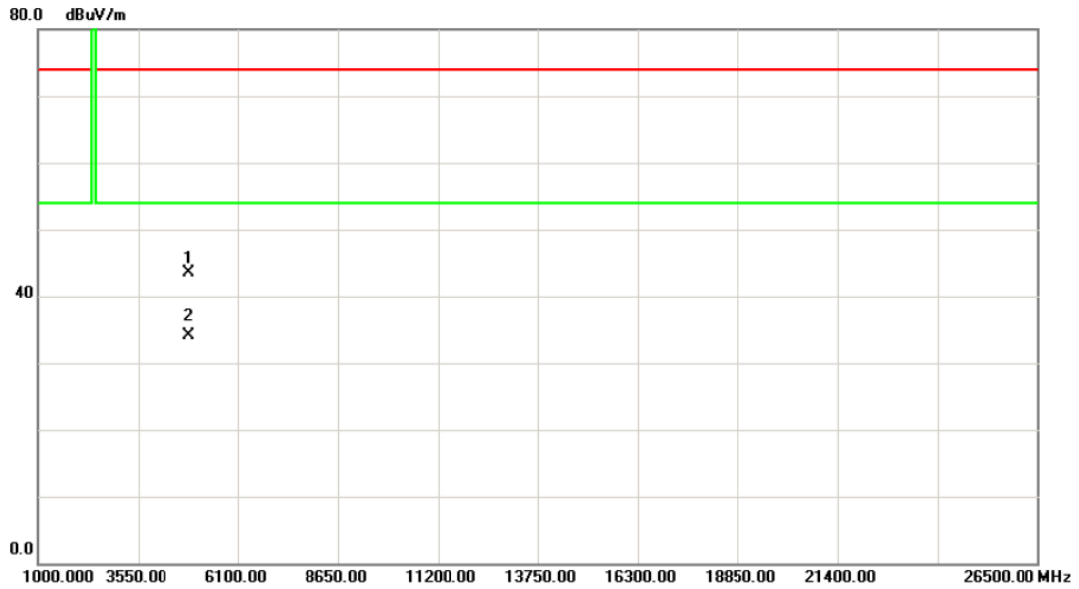

No. Mk.	Freq. MHz	Reading Level dBuV	Correct Factor dB	Measure- ment dBuV/m	Limit dBuV/m	Over dB	Detector	Comment
1	4842.600	39.89	3.66	43.55	74.00	-30.45	peak	
2 *	4842.600	30.37	3.66	34.03	54.00	-19.97	AVG	

Orthogonal Axis :	X
Test Mode :	TX High Channel

Vertical

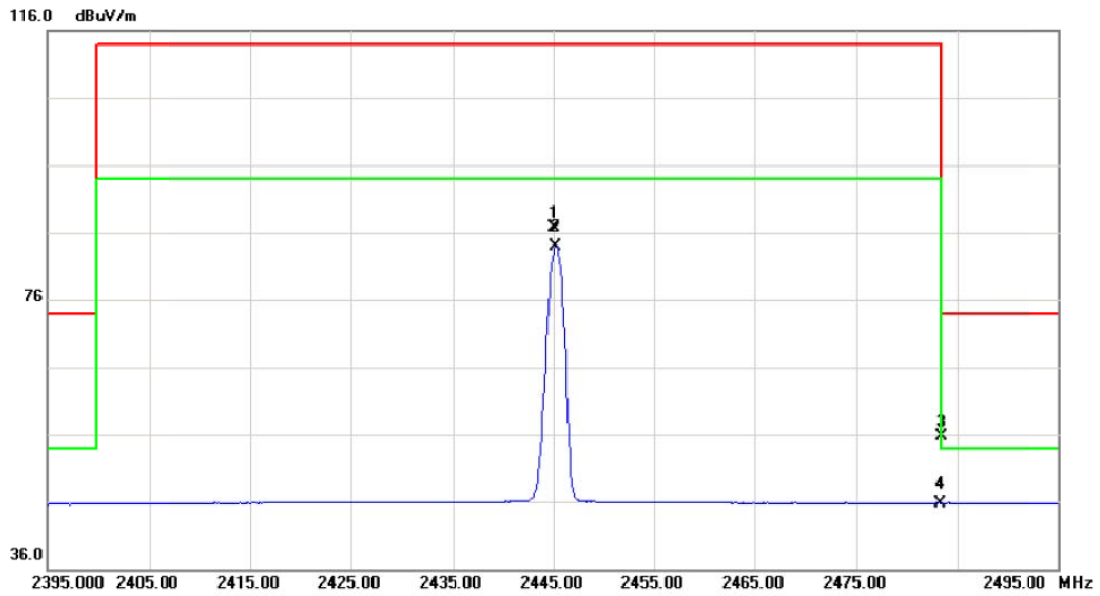

No.	Mk.	Freq. MHz	Reading Level dBuV	Correct Factor dB	Measure- ment dBuV/m	Limit dBuV/m	Over dB	Detector	Comment
1		2445.000	54.74	31.96	86.70	114.0	-27.30	peak	
2		2445.200	51.91	31.96	83.87	94.00	-10.13	AVG	
3		2483.500	23.78	32.01	55.79	74.00	-18.21	peak	
4	*	2483.500	13.76	32.01	45.77	54.00	-8.23	AVG	

Orthogonal Axis :	X
Test Mode :	TX High Channel

Vertical

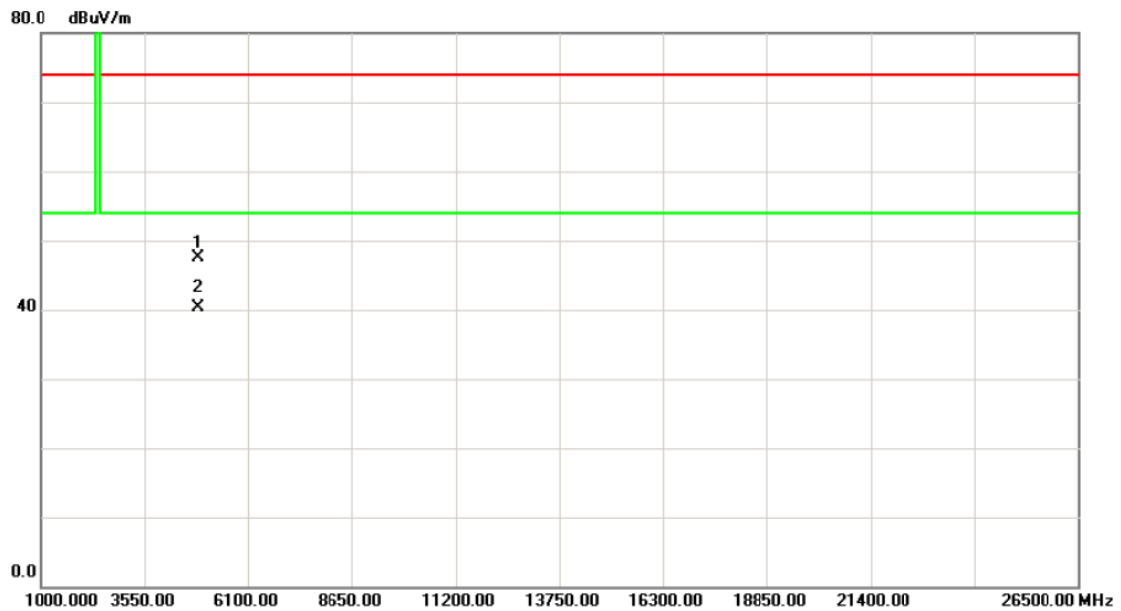

No.	Mk.	Freq. MHz	Reading Level dBuV	Correct Factor dB	Measure- ment dBuV/m	Limit dBuV/m	Over dB	Detector	Comment
1		4890.750	43.69	3.75	47.44	74.00	-26.56	peak	
2	*	4890.750	36.65	3.75	40.40	54.00	-13.60	AVG	

Orthogonal Axis :	X
Test Mode :	TX High Channel

Horizontal

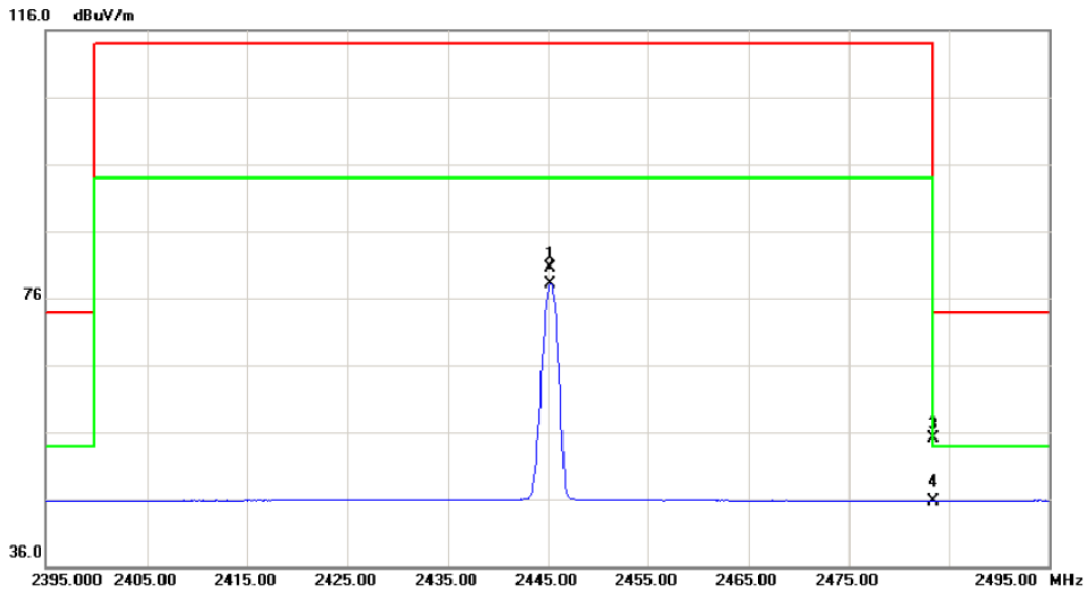

No. Mk.	Freq. MHz	Reading Level dBuV	Correct Factor dB	Measurement dBuV/m	Limit dBuV/m	Over dB	Detector	Comment
1	2445.200	48.60	31.96	80.56	114.0	-33.44	peak	
2	2445.200	46.16	31.96	78.12	94.00	-15.88	AVG	
3	2483.500	23.13	32.01	55.14	74.00	-18.86	peak	
4 *	2483.500	13.73	32.01	45.74	54.00	-8.26	AVG	

Orthogonal Axis :	X
Test Mode :	TX High Channel

Horizontal

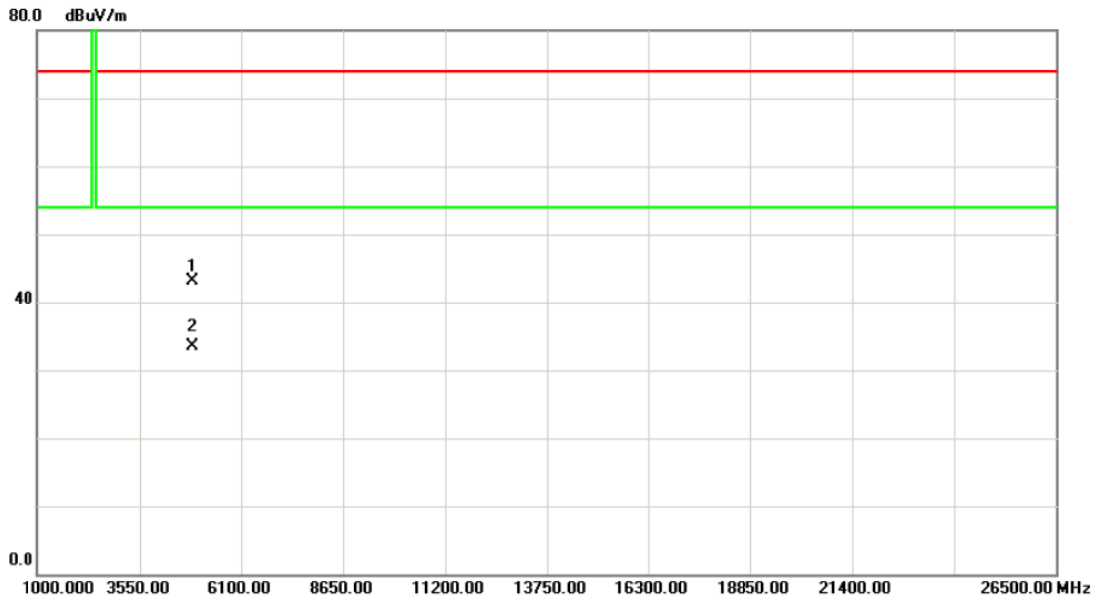

No.	Mk.	Freq. MHz	Reading Level dBuV	Correct Factor dB	Measure- ment dBuV/m	Limit dBuV/m	Over dB	Detector	Comment
1		4890.750	39.35	3.75	43.10	74.00	-30.90	peak	
2	*	4890.750	29.75	3.75	33.50	54.00	-20.50	AVG	

ATTACHMENT E - BANDWIDTH

TX Low Channel

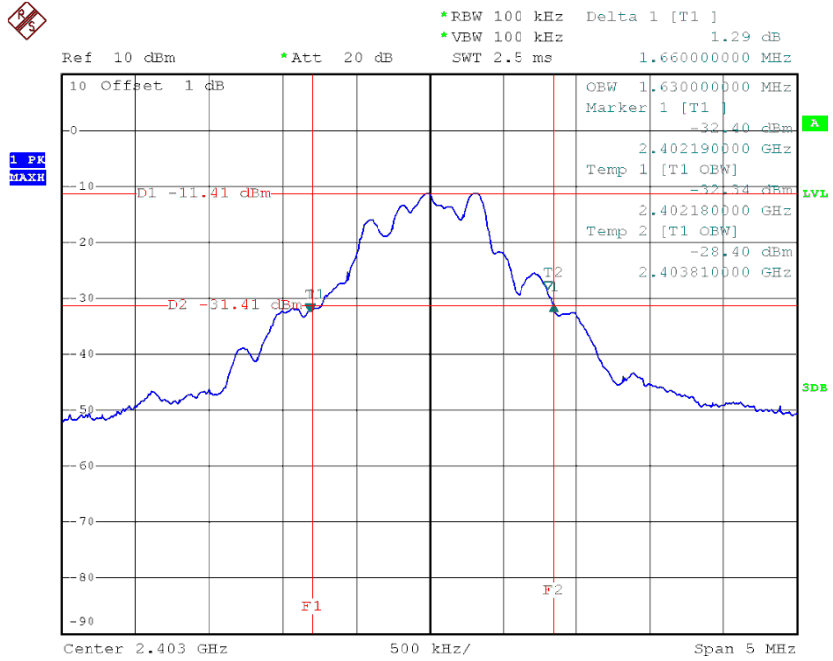

Date: 30.AUG.2014 11:45:10

TX Middle Channel

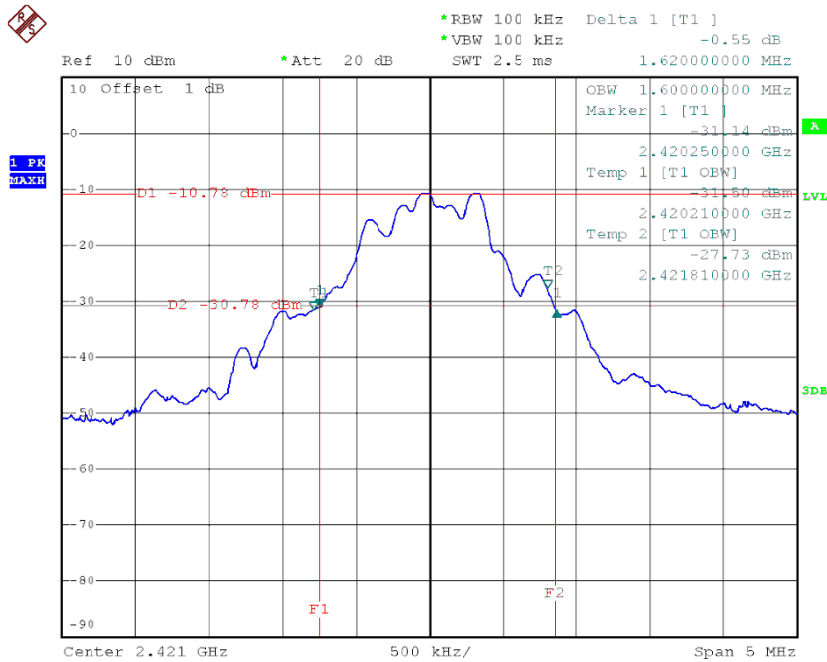

Date: 30.AUG.2014 12:04:23

TX High Channel

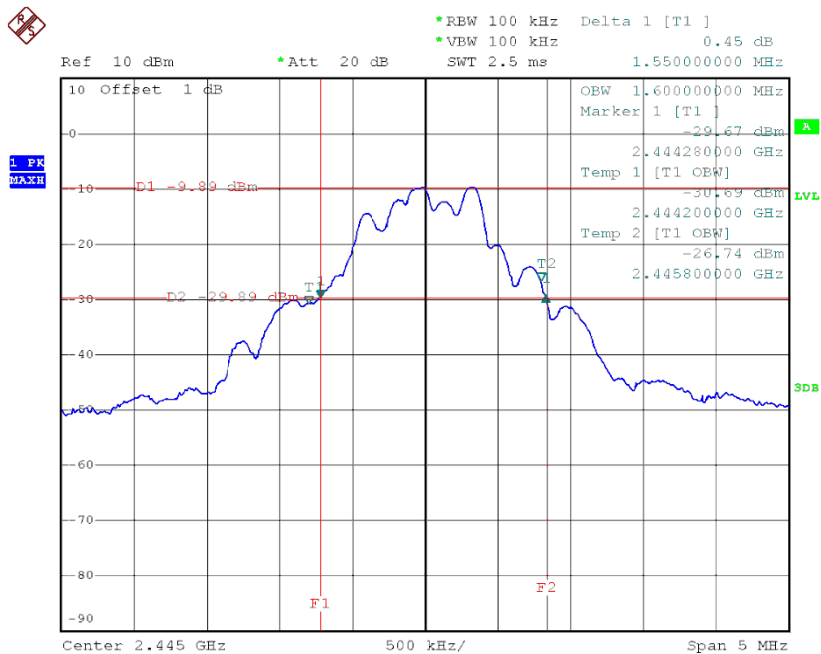

Date: 30.AUG.2014 12:06:16

ATTACHMENT F - ANTENNA CONDUCTED SPURIOUS EMISSION

Test Mode: N/A

Note: "N/A" denotes test is not applicable to this device.