



TESTING LABORATORY
CERTIFICATE #4820.01



FCC PART 15.247

TEST REPORT

For

**HONGKONG U-CLOUDLINK NETWORK
TECHNOLOGY LIMITED**

Suite 603 6/F, Laws Commercial Plaza, 788 Chueng Sha Wan Road, Kowloon Hong Kong

FCC ID: 2AC88-GLMU20A01

Report Type: Original Report	Product Name: TD-LTE Wireless Data Terminal
Report Number:	<u>RDG200911002-00A</u>
Report Date:	<u>2020-12-01</u>
Reviewed By:	Ivan Cao Assistant Manager 
Test Laboratory:	Bay Area Compliance Laboratories Corp. (Dongguan) No.69 Pulongcun, Puxinhu Industry Area, Tangxia, Dongguan, Guangdong, China Tel: +86-769-86858888 Fax: +86-769-86858891 www.baclcorp.com.cn

TABLE OF CONTENTS

GENERAL INFORMATION.....	4
PRODUCT DESCRIPTION FOR EQUIPMENT UNDER TEST (EUT).....	4
OBJECTIVE	4
RELATED SUBMITTAL(S)/GRANT(S).....	4
TEST METHODOLOGY	4
MEASUREMENT UNCERTAINTY	5
TEST FACILITY	5
DECLARATIONS.....	5
SYSTEM TEST CONFIGURATION.....	6
DESCRIPTION OF TEST CONFIGURATION	6
EQUIPMENT MODIFICATIONS	6
EUT EXERCISE SOFTWARE	6
SUPPORT EQUIPMENT LIST AND DETAILS	9
BLOCK DIAGRAM OF TEST SETUP	9
SUMMARY OF TEST RESULTS.....	10
FCC §15.247 (i) & §1.1310 & §2.1093- RF Exposure	11
APPLICABLE STANDARD	11
FCC §15.203 - ANTENNA REQUIREMENT.....	12
APPLICABLE STANDARD	12
ANTENNA CONNECTOR CONSTRUCTION	12
FCC §15.207 (a) – AC LINE CONDUCTED EMISSIONS	13
APPLICABLE STANDARD	13
EUT SETUP.....	13
EMI TEST RECEIVER SETUP.....	13
TEST PROCEDURE	14
CORRECTED AMPLITUDE & MARGIN CALCULATION	14
TEST EQUIPMENT LIST AND DETAILS.....	14
TEST DATA	15
FCC §15.209, §15.205 & §15.247(d) - SPURIOUS EMISSIONS.....	17
APPLICABLE STANDARD	17
EUT SETUP.....	17
EMI TEST RECEIVER & SPECTRUM ANALYZER SETUP	18
TEST PROCEDURE	18
CORRECTED AMPLITUDE & MARGIN CALCULATION	18
TEST EQUIPMENT LIST AND DETAILS.....	19
TEST DATA	19
FCC §15.247(a) (2)–6 dB EMISSION BANDWIDTH.....	28
APPLICABLE STANDARD	28
TEST PROCEDURE	28
TEST EQUIPMENT LIST AND DETAILS.....	28
TEST DATA	28
FCC §15.247(b) (3) - MAXIMUM PEAK CONDUCTED OUTPUT POWER.....	36
APPLICABLE STANDARD	36
TEST PROCEDURE	36
TEST EQUIPMENT LIST AND DETAILS.....	36

TEST DATA37

FCC §15.247(d)– 100 kHz BANDWIDTH OF FREQUENCY BAND EDGE.....38

 APPLICABLE STANDARD38

 TEST PROCEDURE38

 TEST EQUIPMENT LIST AND DETAILS.....38

 TEST DATA39

FCC §15.247(e) - POWER SPECTRAL DENSITY44

 APPLICABLE STANDARD44

 TEST PROCEDURE44

 TEST EQUIPMENT LIST AND DETAILS.....44

 TEST DATA44

GENERAL INFORMATION

Product Description for Equipment under Test (EUT)

EUT Name:	TD-LTE Wireless Data Terminal
EUT Model:	GLMU20A01
Operation Frequency:	2412-2462 MHz(802.11b/g/n ht20), 2422-2452 MHz(802.11n ht40)
Maximum Peak Output Power (Conducted):	22.78 dBm(802.11b/g/n)
Modulation Type:	DSSS, OFDM(802.11b/g/n)
Antenna Gain^Δ:	2.73 dBi
Rated Input Voltage:	DC 3.85V from battery or 5V form USB port
Serial Number:	RDG200911002-RF -S1
EUT Received Date:	2020.09.14
EUT Received Status:	Good

Objective

This report is prepared on behalf of **HONGKONG UCLOUDLINK NETWORK TECHNOLOGY LIMITED** in accordance with Part 2, Subpart J, Part 15, Subparts A and C of the Federal Communications Commission's rules.

The tests were performed in order to determine the compliance of the EUT with FCC Rules Part 15-Subpart C, section 15.203, 15.205, 15.207, 15.209 and 15.247 rules.

Related Submittal(s)/Grant(s)

FCC Part 22H, 24E,27,90 PCB submissions with FCC ID: 2AC88-GLMU20A01.

Test Methodology

All measurements contained in this report were conducted with ANSI C63.10-2013, American National Standard of Procedures for Compliance Testing of Unlicensed Wireless Devices and KDB 558074 D01 DTS Meas Guidance v05r02.

All emissions measurement was performed and Bay Area Compliance Laboratories Corp. (Dongguan).

Measurement Uncertainty

Parameter	Measurement Uncertainty
Occupied Channel Bandwidth	±5 %
RF output power, conducted	±0.61dB
Power Spectral Density, conducted	±0.61 dB
Unwanted Emissions, radiated	30M~200MHz: 4.55 dB,200M~1GHz: 5.92 dB,1G~6GHz: 4.98 dB, 6G~18GHz: 5.89 dB,18G~26.5G:5.47 dB,26.5G~40G:5.63 dB
Unwanted Emissions, conducted	±1.5 dB
Temperature	±1 °C
Humidity	±5%
DC and low frequency voltages	±0.4%
Duty Cycle	1%
AC Power Lines Conducted Emission	3.12 dB (150 kHz to 30 MHz)

Note: Otherwise required by the applicant or Product Regulations, Decision Rule in this report did not consider the uncertainty. The extended uncertainty given in this report is obtained by combining the standard uncertainty times the coverage factor K with the 95% confidence interval.

Test Facility

The Test site used by Bay Area Compliance Laboratories Corp. (Dongguan) to collect test data is located on the No.69 Pulongcun, Puxinhu Industry Area, Tangxia, Dongguan, Guangdong, China.

The lab has been recognized as the FCC accredited lab under the KDB 974614 D01 and is listed in the FCC Public Access Link (PAL) database, FCC Registration No. : 897218, the FCC Designation No. : CN1220.

The lab has been recognized by Innovation, Science and Economic Development Canada to test to Canadian radio equipment requirements, the CAB identifier: CN0022.

Declarations

BACL is not responsible for the authenticity of any test data provided by the applicant. Data included from the applicant that may affect test results are marked with a triangle symbol “ Δ ”. Customer model name, addresses, names, trademarks etc. are not considered data.

Unless otherwise stated the results shown in this test report refer only to the sample(s) tested.

This report cannot be reproduced except in full, without prior written approval of the Company.

This report is valid only with a valid digital signature. The digital signature may be available only under the Adobe software above version 7.0.

This report may contain data that are not covered by the accreditation scope and shall be marked with an asterisk “★”.

SYSTEM TEST CONFIGURATION

Description of Test Configuration

The system was configured for testing in Engineering Mode, which was provided by the manufacturer.

For 2.4GHz band, total 11 channels are provided:

Channel	Frequency (MHz)	Channel	Frequency (MHz)
1	2412	7	2442
2	2417	8	2447
3	2422	9	2452
4	2427	10	2457
5	2432	11	2462
6	2437	/	/

For 802.11b, 802.11g, and 802.11n ht20 modes were test with channel 1, 6, 11.

For 802.11n ht40 modes were test with channel 3, 6, 9.

The worst-case data rates are determined to be as follows for each mode based upon investigations by measuring the average power and PSD across all data rates, bandwidths, and modulations.

Equipment Modifications

No modification was made to the EUT.

EUT Exercise Software

The software “QRCT3” was used for testing, which was provided by manufacturer. The maximum power was configured as below table, that provided by the manufacturer^Δ :

Mode	Channel	Frequency (MHz)	Data rate	Power level Setting
802.11 b	Low	2412	1 Mbps	8
	Middle	2437	1 Mbps	11
	High	2462	1 Mbps	10
802.11 g	Low	2412	6 Mbps	5
	Middle	2437	6 Mbps	7
	High	2462	6 Mbps	6
802.11n ht20	Low	2412	MCS0	4
	Middle	2437	MCS0	6
	High	2462	MCS0	5
802.11n ht40	Low	2422	MCS0	7
	Middle	2437	MCS0	7
	High	2452	MCS0	7

The maximum duty cycle as following table:

Test mode	T _{on} (ms)	T _{on+off} (ms)	Duty Cycle (%)
802.11b	100	100	100
802.11g	1.395	1.563	89.25
802.11n ht20	1.316	1.485	88.62
802.11n ht40	0.549	0.841	65.28

802.11b

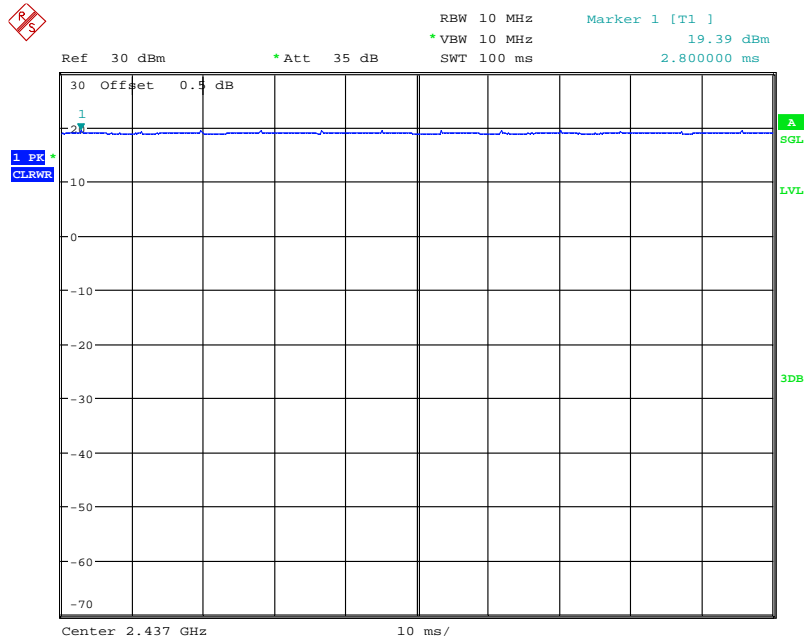

Date: 20.NOV.2020 18:57:45

802.11g

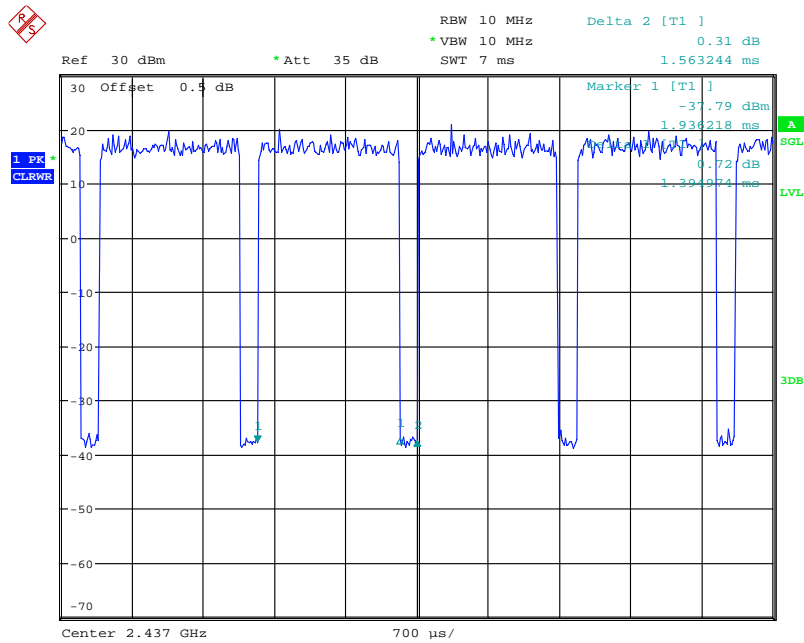

Date: 20.NOV.2020 18:58:40

802.11n ht20

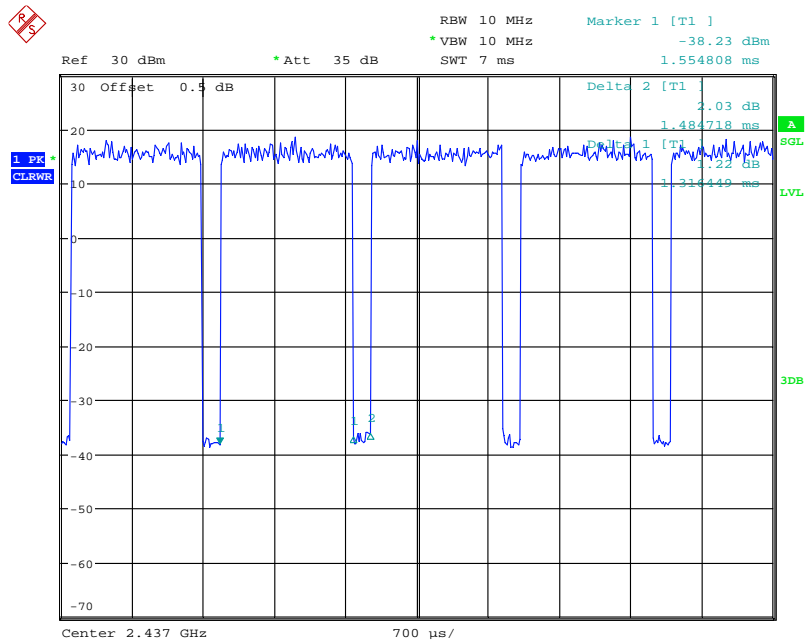

Date: 20.NOV.2020 18:59:27

802.11n ht40

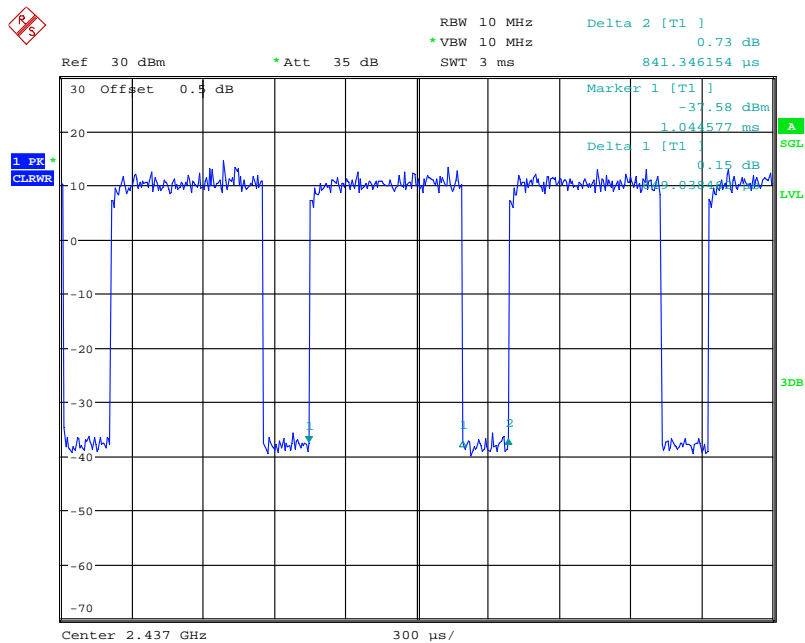

Date: 20.NOV.2020 18:56:15

Support Equipment List and Details

Manufacturer	Description	Model	Serial Number
tiejia	Adapter	TEKA006-0501000CHU	TEKA000501000
huawei	Phone	COL-AL10	48451991258
Apple	Phone	A1864	2017011606002397
Huawei	Phone	JEF-AN00	Eg546842158

Support Cable List and Details

Cable Description	Shielding Type	Ferrite Core	Length (m)	From Port	To
USB Cable	No	No	1	Adapter	EUT
USB Cable	No	No	0.1	EUT	Phone
USB Cable	No	No	0.1	EUT	Phone
USB Cable	No	No	0.1	EUT	Phone

Block Diagram of Test Setup

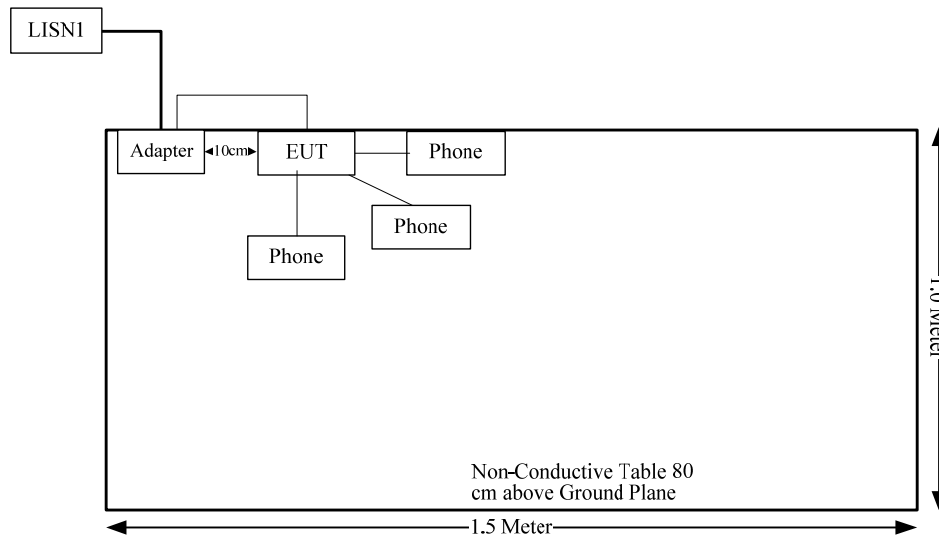

SUMMARY OF TEST RESULTS

FCC Rules	Description of Test	Result
FCC §15.247 (i) & §1.1310 & §2.1093	RF Exposure	Compliance
§15.203	Antenna Requirement	Compliance
§15.207 (a)	AC Line Conducted Emissions	Compliance
§15.205, §15.209, §15.247(d)	Spurious Emissions	Compliance
§15.247 (a)(2)	6 dB Bandwidth	Compliance
§15.247(b)(3)	Maximum Conducted Output Power	Compliance
§15.247(d)	100 kHz Bandwidth of Frequency Band Edge	Compliance
§15.247(e)	Power Spectral Density	Compliance

FCC §15.247 (i) & §1.1310 & §2.1093- RF Exposure

Applicable Standard

According to §15.247(i) and §1.1310, systems operating under the provisions of this section shall be operated in a manner that ensure that the public is not exposed to radio frequency energy level in excess of the Commission's guideline.

Measurement Result

Result: Compliance. Please refer to the SAR report: RDG200911002-SA.

FCC §15.203 - ANTENNA REQUIREMENT

Applicable Standard

According to § 15.203, an intentional radiator shall be designed to ensure that no antenna other than that furnished by the responsible party shall be used with the device. The use of a permanently attached antenna or of an antenna that uses a unique coupling to the intentional radiator shall be considered sufficient to comply with the provisions of this section. The manufacturer may design the unit so that a broken antenna can be replaced by the user, but the user of a standard antenna jack or electrical connector is prohibited. The structure and application of the EUT were analyzed to determine compliance with section §15.203 of the rules. §15.203 state that the subject device must meet the following criteria:

- a. Antenna must be permanently attached to the unit.
- b. Antenna must use a unique type of connector to attach to the EUT.
- c. Unit must be professionally installed, and installer shall be responsible for verifying that the correct antenna is employed with the unit.

Antenna Connector Construction

The EUT has one internal FPC antenna arrangement, fulfill the requirement of this section. Please refer to the EUT photos.

Antenna Type	input impedance (Ohm)	Antenna Gain /Frequency Range
FPC	50	2.73 dBi/2.4~2.5GHz

Result: Compliance.

FCC §15.207 (a) – AC LINE CONDUCTED EMISSIONS

Applicable Standard

FCC§15.207(a).

EUT Setup

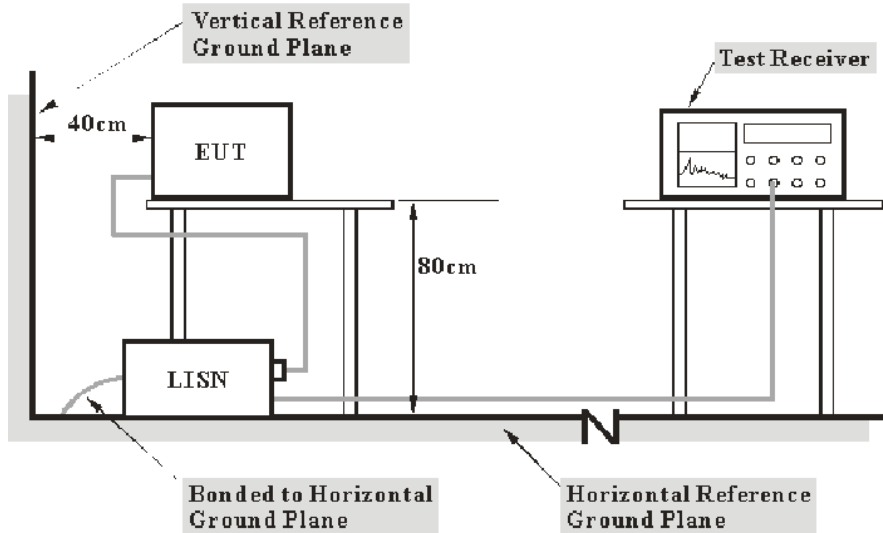

- Note: 1. Support units were connected to second LISN.
 2. Both of LISNs (AMN) 80 cm from EUT and at the least 80 cm from other units and other metal planes support units.

The setup of EUT is according with per ANSI C63.10-2013 measurement procedure. The specification used was with the FCC Part 15.207 limits.

The spacing between the peripherals was 10 cm.

The adapter was connected to the main LISN with a 120 V/60 Hz AC power source.

EMI Test Receiver Setup

The EMI test receiver was set to investigate the spectrum from 150 kHz to 30 MHz.

During the conducted emission test, the EMI test receiver was set with the following configurations:

Frequency Range	IF B/W
150 kHz – 30 MHz	9 kHz

Test Procedure

During the conducted emission test, the adapter was connected to the outlet of the first LISN.

The frequency and amplitude of the six highest ac power-line conducted emissions relative to the limit, measured over all the current-carrying conductors of the EUT power cords, and the operating frequency or frequency to which the EUT is tuned (if appropriate), should be reported, unless such emissions are more than 20 dB below the limit. AC power-line conducted emissions measurements are to be separately carried out only on each of the phase (“hot”) line(s) and (if used) on the neutral line(s), but not on the ground [protective earth] line(s). If less than six emission frequencies are within 20 dB of the limit, then the noise level of the measuring instrument at representative frequencies should be reported. The specific conductor of the power-line cord for each of the reported emissions should be identified. Measure the six highest emissions with respect to the limit on each current-carrying conductor of each power cord associated with the EUT (but not the power cords of associated or peripheral equipment that are part of the test configuration). Then, report the six highest emissions with respect to the limit from among all the measurements identifying the frequency and specific current-carrying conductor identified with the emission. The six highest emissions should be reported for each of the current-carrying conductors, or the six highest emissions may be reported over all the current-carrying conductors.

Corrected Amplitude & Margin Calculation

The basic equation is as follows:

$$V_C = V_R + A_C + VDF$$

$$C_f = A_C + VDF$$

Herein,

V_C (cord. Reading): corrected voltage amplitude

V_R : reading voltage amplitude

A_C : attenuation caused by cable loss

VDF: voltage division factor of AMN

C_f : Correction Factor

The “**Margin**” column of the following data tables indicates the degree of compliance within the applicable limit. For example, a margin of 7dB means the emission is 7dB below the limit. The equation for margin calculation is as follows:

$$\text{Margin} = \text{Limit} - \text{Corrected Amplitude}$$

Test Equipment List and Details

Manufacturer	Description	Model	Serial Number	Calibration Date	Calibration Due Date
R&S	LISN	ENV 216	101614	2020-09-12	2021-09-12
R&S	EMI Test Receiver	ESCI	101121	2020-07-07	2021-07-07
MICRO-COAX	Coaxial Cable	C-NJNJ-50	C-0200-01	2020-09-05	2021-09-05
R&S	Test Software	EMC32	Version 9.10.00	N/A	N/A

* **Statement of Traceability:** Bay Area Compliance Laboratories Corp. (Dongguan) attests that all calibrations have been performed, traceable to National Primary Standards and International System of Units (SI).

Test Data

Environmental Conditions

Temperature:	23.6°C
Relative Humidity:	52%
ATM Pressure:	100.9 kPa
Tester:	Barry Yang
Test Date:	2020-10-23

Test Result: *Compliance*

Test Mode: *Transmitting(802.11b mode high channel was the worst)*

AC120 V, 60 Hz, Line:

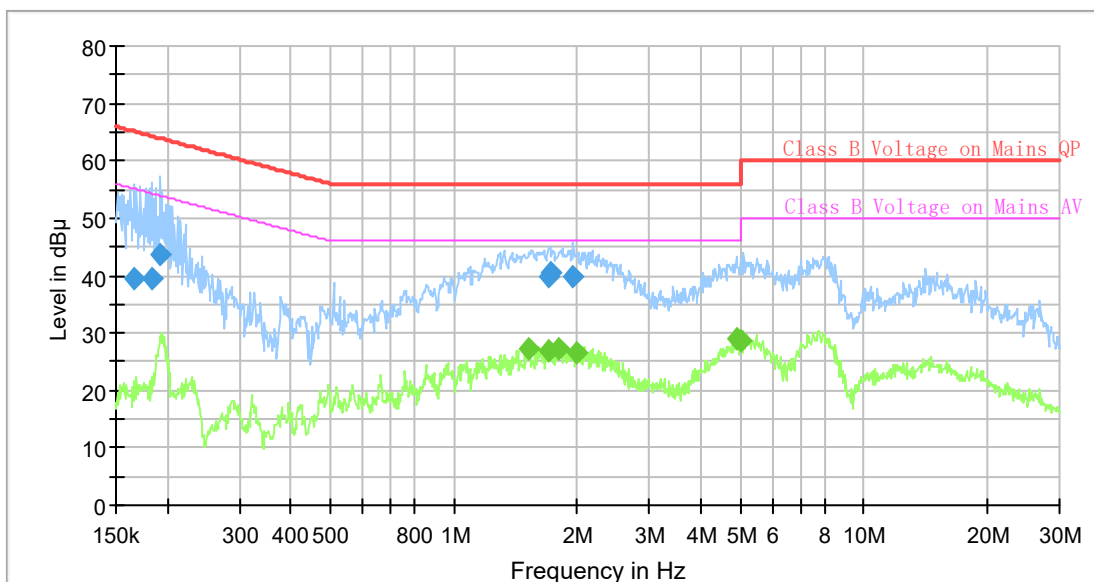

Final Result

Frequency (MHz)	QuasiPeak (dB μV)	Average (dB μV)	Limit (dB μV)	Margin (dB)	Bandwidth (kHz)	Line	Corr. (dB)
0.166563	39.42	---	65.13	25.71	9.000	L1	9.6
0.183119	39.51	---	64.34	24.83	9.000	L1	9.6
0.192484	43.57	---	63.93	20.36	9.000	L1	9.6
1.525141	---	27.21	46.00	18.79	9.000	L1	9.7
1.702015	39.85	---	56.00	16.15	9.000	L1	9.7
1.710525	---	26.82	46.00	19.18	9.000	L1	9.7
1.719078	40.48	---	56.00	15.52	9.000	L1	9.7
1.798001	---	27.12	46.00	18.88	9.000	L1	9.7
1.957100	39.69	---	56.00	16.31	9.000	L1	9.7
1.986604	---	26.38	46.00	19.62	9.000	L1	9.7
4.924186	---	28.91	46.00	17.09	9.000	L1	9.7
4.998419	---	28.74	46.00	17.26	9.000	L1	9.7

AC120 V, 60 Hz, Neutral:

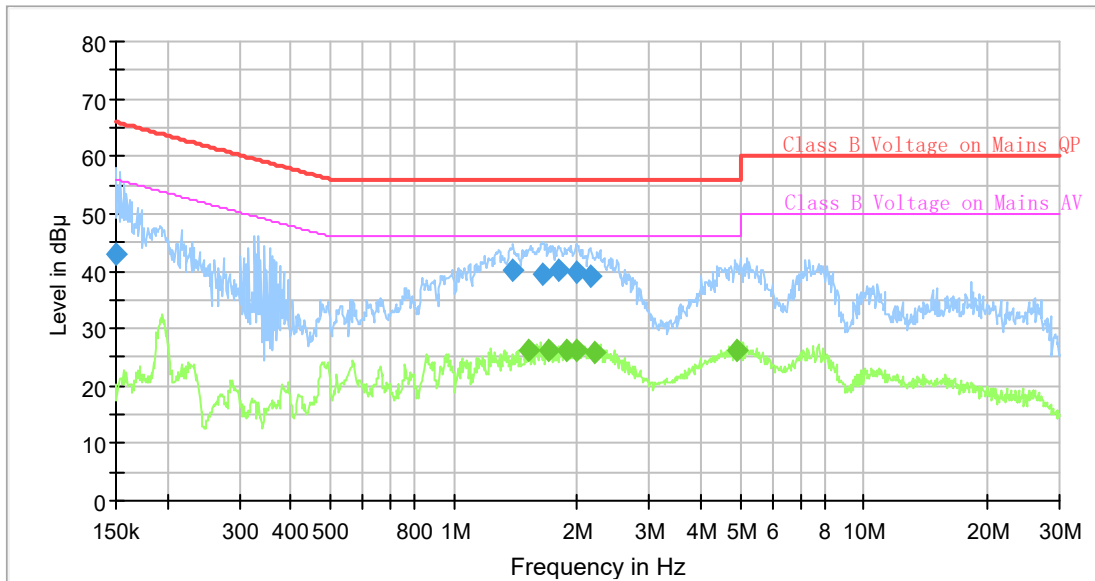

Final Result

Frequency (MHz)	QuasiPeak (dB µ V)	Average (dB µ V)	Limit (dB µ V)	Margin (dB)	Bandwidth (kHz)	Line	Corr. (dB)
0.150000	42.87	---	66.00	23.13	9.000	N	9.6
1.394186	40.02	---	56.00	15.98	9.000	N	9.6
1.525141	---	26.13	46.00	19.87	9.000	N	9.6
1.651836	39.41	---	56.00	16.59	9.000	N	9.6
1.710525	---	26.21	46.00	19.79	9.000	N	9.6
1.798001	40.05	---	56.00	15.95	9.000	N	9.6
1.889951	---	26.11	46.00	19.89	9.000	N	9.6
1.986604	39.71	---	56.00	16.29	9.000	N	9.6
1.986604	---	26.28	46.00	19.72	9.000	N	9.6
2.151633	39.14	---	56.00	16.86	9.000	N	9.6
2.194990	---	25.98	46.00	20.02	9.000	N	9.6
4.924186	---	26.33	46.00	19.67	9.000	N	9.6

FCC §15.209, §15.205 & §15.247(d) - SPURIOUS EMISSIONS

Applicable Standard

FCC §15.247 (d); §15.209; §15.205;

EUT Setup

Below 1GHz:

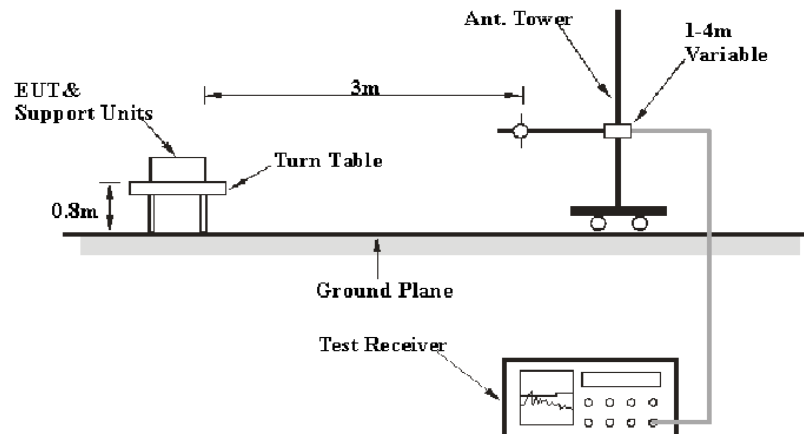

Above 1GHz:

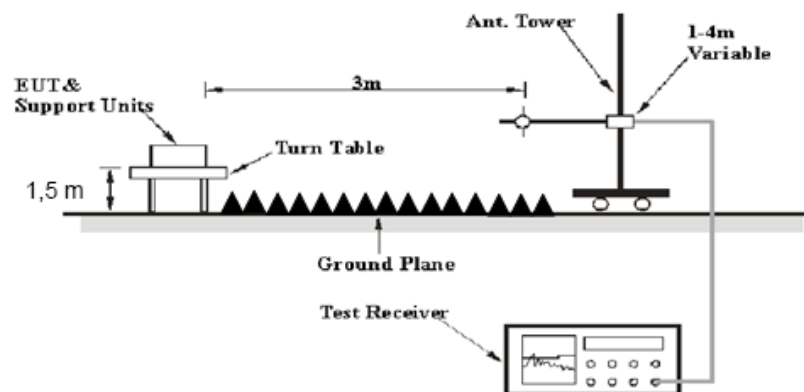

The radiated emission below 1GHz tests were performed in the 10 meters chamber test site, above 1GHz tests were performed in the 3 meters chamber test site B, using the setup accordance with the ANSI C63.10-2013. The specification used was the FCC 15.209, and FCC 15.247 limits.

The external I/O cables were draped along the test table and formed a bundle 30 to 40 cm long in the middle.

The spacing between the peripherals was 10 cm.

EMI Test Receiver & Spectrum Analyzer Setup

The system was investigated from 30 MHz to 25 GHz.

During the radiated emission test, the EMI test receiver & Spectrum Analyzer Setup were set with the following configurations:

30MHz-1000MHz:

Measurement	RBW	Video B/W	IF B/W
QP	120 kHz	300 kHz	120kHz

1GHz- 25GHz:

Measurement	Duty cycle	RBW	Video B/W
PK	Any	1MHz	3 MHz
AV	>98%	1MHz	10 Hz
	<98%	1MHz	1/T

Note: T is minimum transmission duration

If the maximized peak measured value complies with under the QP/Average limit more than 6dB, then it is unnecessary to perform an QP/Average measurement.

Test Procedure

Maximizing procedure was performed on the highest emissions to ensure that the EUT complied with all installation combinations.

Data was recorded in Quasi-peak detection mode for frequency range of 30 MHz-1 GHz, peak and Average detection modes for frequencies above 1 GHz.

Corrected Amplitude & Margin Calculation

The Corrected Amplitude is calculated by adding the Antenna Factor and Cable Loss, and subtracting the Amplifier Gain from the Meter Reading. The basic equation is as follows:

$$\text{Corrected Amplitude} = \text{Meter Reading} + \text{Antenna Factor} + \text{Cable Loss} - \text{Amplifier Gain}$$

The “**Margin**” column of the following data tables indicates the degree of compliance with the applicable limit. For example, a margin of 7dB means the emission is 7dB below the limit. The equation for margin calculation is as follows:

$$\text{Margin} = \text{Limit} - \text{Corrected Amplitude}$$

Test Equipment List and Details

Manufacturer	Description	Model	Serial Number	Calibration Date	Calibration Due Date
Radiation Below 1GHz					
Sunol Sciences	Antenna	JB3	A060611-2	2020-08-25	2023-08-25
R&S	EMI Test Receiver	ESCI	100224	2020-09-12	2021-09-12
Unknown	Coaxial Cable	C-NJNJ-50	C-1000-01	2020-09-05	2021-09-05
Unknown	Coaxial Cable	C-NJNJ-50	C-0400-02	2020-09-05	2021-09-05
Unknown	Coaxial Cable	C-NJNJ-50	C-0530-01	2020-09-24	2021-09-24
Sonoma	Amplifier	310N	185914	2020-10-13	2021-10-13
Farad	Test Software	EZ-EMC	V1.1.4.2	N/A	N/A
Radiation Above 1GHz					
ETS-Lindgren	Horn Antenna	3115	000 527 35	2018-10-12	2021-10-12
Ducommun Technologies	Horn Antenna	ARH-4223-02	1007726-01 1304	2017-12-06	2020-12-05
Agilent	Spectrum Analyzer	E4440A	SG43360054	2020-07-07	2021-07-07
Unknown	Coaxial Cable	C-SJSJ-50	C-0800-01	2020-09-05	2021-09-05
Unknown	Coaxial Cable	C-2.4J2.4J-50	C-0700-02	2020-06-27	2021-06-27
Mini-Circuit	Amplifier	ZVA-213-S+	54201245	2020-09-05	2021-09-05
Quinstar	Amplifier	QLW-18405536-JO	15964001001	2020-06-27	2021-06-27
Farad	Test Software	EZ-EMC	V1.1.4.2	N/A	N/A
E-Microwave	Band-stop Filters	OBSF-2400-2483.5-S	OE01601525	2020-06-16	2021-06-16
Micro-tronics	High Pass Filter	HPM50111	S/N-G217	2020-06-16	2021-06-16

* **Statement of Traceability:** Bay Area Compliance Laboratories Corp. (Dongguan) attests that all calibrations have been performed, traceable to National Primary Standards and International System of Units (SI).

Test Data**Environmental Conditions**

Test Items	Radiation Below 1GHz	Radiation Above 1GHz
Temperature:	27.4 °C	26 °C
Relative Humidity:	41 %	37 %
ATM Pressure:	100.9 kPa	100.8 kPa
Tester:	Michael Zhang	Bond Qin
Test Date:	2020-10-30	2020-10-24

Test Result: Compliance, please Refer to the following data

Test Mode: Transmitting

1) 30MHz-1GHz(802.11b_High channel was the worst)

Horizontal:

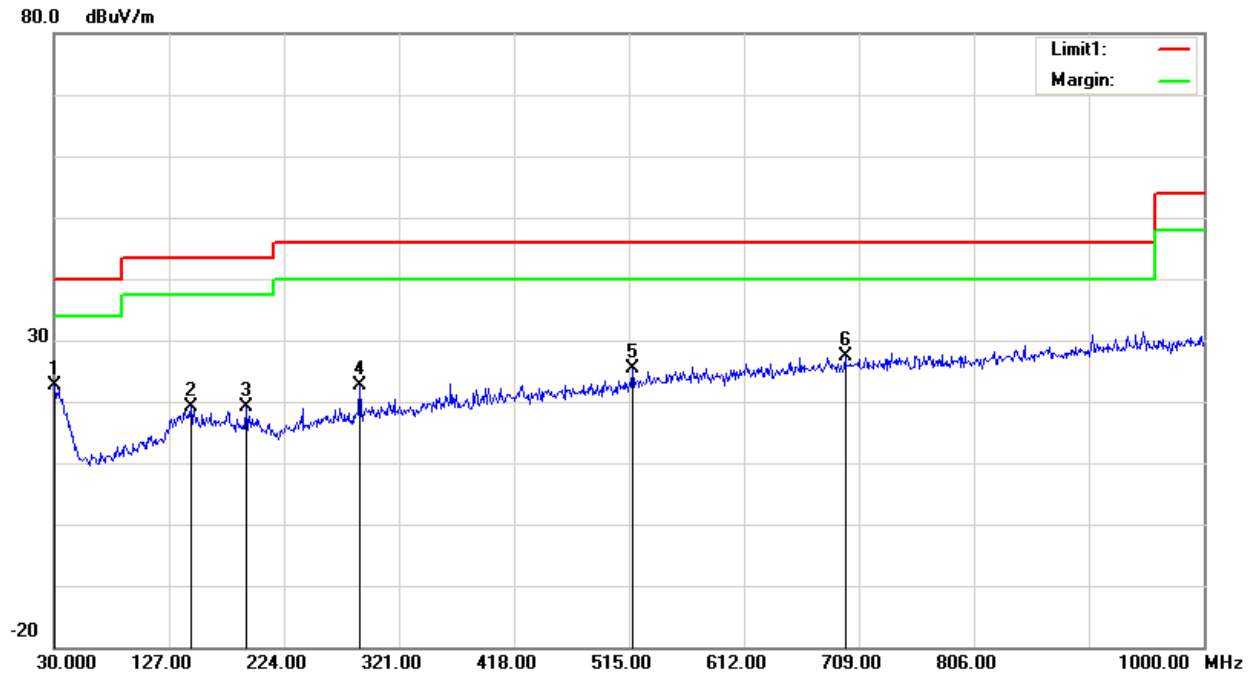

Frequency (MHz)	Receiver Reading (dBuV)	Detector	Correction Factor (dB/m)	Cord. Amp. (dBuV/m)	Limit (dBuV/m)	Margin (dB)
30.0000	26.75	peak	-4.10	22.65	40.00	17.35
145.4300	28.29	peak	-9.11	19.18	43.50	24.32
191.9900	29.42	peak	-10.32	19.10	43.50	24.40
288.0200	30.79	peak	-8.23	22.56	46.00	23.44
517.9100	28.03	peak	-2.72	25.31	46.00	20.69
697.3600	27.38	peak	0.11	27.49	46.00	18.51

Vertical:

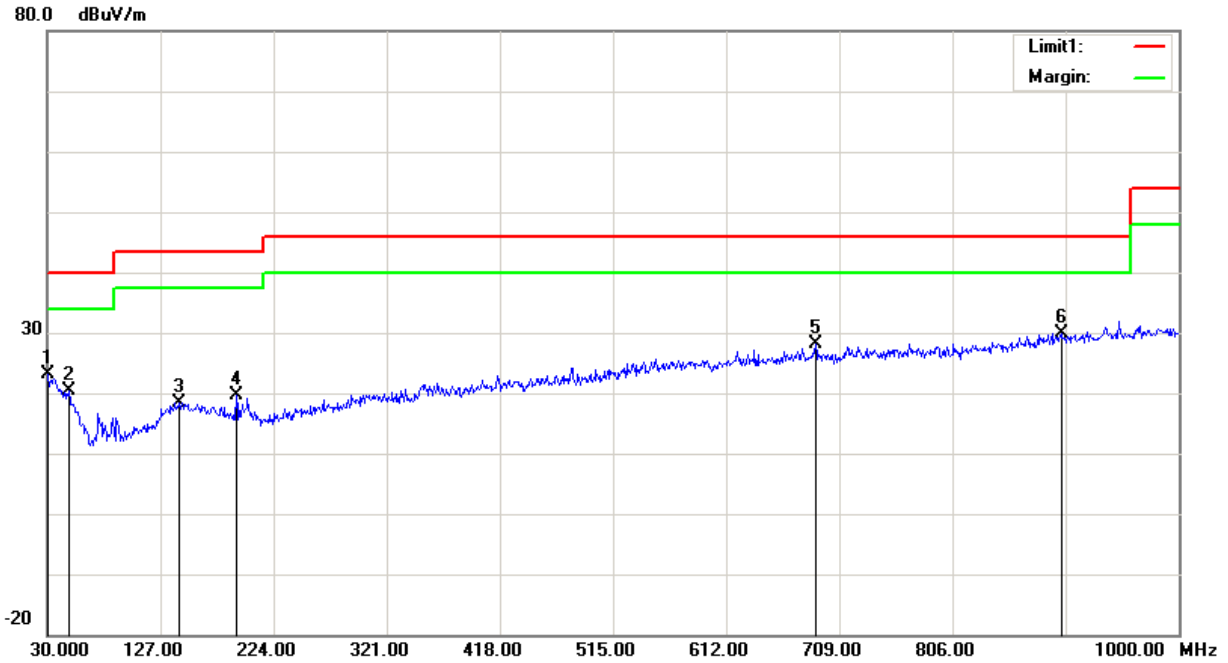

Frequency (MHz)	Receiver Reading (dBuV)	Detector	Correction Factor (dB/m)	Cord. Amp. (dBuV/m)	Limit (dBuV/m)	Margin (dB)
30.9700	27.84	peak	-4.66	23.18	40.00	16.82
48.4300	35.45	peak	-15.12	20.33	40.00	19.67
143.4900	27.40	peak	-9.02	18.38	43.50	25.12
191.9900	30.02	peak	-10.32	19.70	43.50	23.80
688.6300	27.89	peak	0.17	28.06	46.00	17.94
899.1200	26.51	peak	3.41	29.92	46.00	16.08

2) 1-25GHz:

802.11b Mode:

Frequency (MHz)	Receiver		Rx Antenna		Cable loss (dB)	Amplifier Gain (dB)	Corrected Amplitude (dB μ V/m)	Limit (dB μ V/m)	Margin (dB)
	Reading (dB μ V)	Detector	Polar (H/V)	Factor (dB/m)					
Low Channel: 2412 MHz									
2412.00	73.29	PK	H	28.12	1.81	0.00	103.22	N/A	N/A
2412.00	69.92	AV	H	28.12	1.81	0.00	99.85	N/A	N/A
2412.00	70.28	PK	V	28.12	1.81	0.00	100.21	N/A	N/A
2412.00	66.69	AV	V	28.12	1.81	0.00	96.62	N/A	N/A
2390.00	27.82	PK	H	28.08	1.80	0.00	57.70	74.00	16.30
2390.00	17.39	AV	H	28.08	1.80	0.00	47.27	54.00	6.73
4824.00	37.95	PK	H	32.95	3.19	25.62	48.47	74.00	25.53
4824.00	25.41	AV	H	32.95	3.19	25.62	35.93	54.00	18.07
7236.00	36.08	PK	H	35.81	4.77	25.64	51.02	74.00	22.98
7236.00	23.41	AV	H	35.81	4.77	25.64	38.35	54.00	15.65
Middle Channel: 2437 MHz									
2437.00	72.49	PK	H	28.17	1.82	0.00	102.48	N/A	N/A
2437.00	69.01	AV	H	28.17	1.82	0.00	99.00	N/A	N/A
2437.00	68.95	PK	V	28.17	1.82	0.00	98.94	N/A	N/A
2437.00	65.32	AV	V	28.17	1.82	0.00	95.31	N/A	N/A
4874.00	38.46	PK	H	33.05	3.26	25.65	49.12	74.00	24.88
4874.00	26.30	AV	H	33.05	3.26	25.65	36.96	54.00	17.04
7311.00	35.68	PK	H	36.01	4.64	25.71	50.62	74.00	23.38
7311.00	23.41	AV	H	36.01	4.64	25.71	38.35	54.00	15.65
High Channel: 2462 MHz									
2462.00	72.93	PK	H	28.22	1.83	0.00	102.98	N/A	N/A
2462.00	69.20	AV	H	28.22	1.83	0.00	99.25	N/A	N/A
2462.00	69.87	PK	V	28.22	1.83	0.00	99.92	N/A	N/A
2462.00	66.36	AV	V	28.22	1.83	0.00	96.41	N/A	N/A
2483.50	26.93	PK	H	28.27	1.84	0.00	57.04	74.00	16.96
2483.50	15.37	AV	H	28.27	1.84	0.00	45.48	54.00	8.52
4924.00	37.20	PK	H	33.15	3.27	25.65	47.97	74.00	26.03
4924.00	25.10	AV	H	33.15	3.27	25.65	35.87	54.00	18.13
7386.00	35.88	PK	H	36.20	4.51	25.79	50.80	74.00	23.20
7386.00	23.41	AV	H	36.20	4.51	25.79	38.33	54.00	15.67

802.11g Mode:

Frequency (MHz)	Receiver		Rx Antenna		Cable loss (dB)	Amplifier Gain (dB)	Corrected Amplitude (dB μ V/m)	Limit (dB μ V/m)	Margin (dB)
	Reading (dB μ V)	Detector	Polar (H/V)	Factor (dB/m)					
Low Channel: 2412 MHz									
2412.00	73.91	PK	H	28.12	1.81	0.00	103.84	N/A	N/A
2412.00	62.57	AV	H	28.12	1.81	0.00	92.50	N/A	N/A
2412.00	70.48	PK	V	28.12	1.81	0.00	100.41	N/A	N/A
2412.00	59.20	AV	V	28.12	1.81	0.00	89.13	N/A	N/A
2390.00	39.50	PK	H	28.08	1.80	0.00	69.38	74.00	4.62
2390.00	23.64	AV	H	28.08	1.80	0.00	53.52	54.00	0.48
4824.00	36.41	PK	H	32.95	3.19	25.62	46.93	74.00	27.07
4824.00	23.89	AV	H	32.95	3.19	25.62	34.41	54.00	19.59
7236.00	36.00	PK	H	35.81	4.77	25.64	50.94	74.00	23.06
7236.00	23.41	AV	H	35.81	4.77	25.64	38.35	54.00	15.65
Middle Channel: 2437 MHz									
2437.00	73.18	PK	H	28.17	1.82	0.00	103.17	N/A	N/A
2437.00	61.52	AV	H	28.17	1.82	0.00	91.51	N/A	N/A
2437.00	70.01	PK	V	28.17	1.82	0.00	100.00	N/A	N/A
2437.00	58.75	AV	V	28.17	1.82	0.00	88.74	N/A	N/A
4874.00	36.25	PK	H	33.05	3.26	25.65	46.91	74.00	27.09
4874.00	24.01	AV	H	33.05	3.26	25.65	34.67	54.00	19.33
7311.00	35.52	PK	H	36.01	4.64	25.71	50.46	74.00	23.54
7311.00	23.42	AV	H	36.01	4.64	25.71	38.36	54.00	15.64
High Channel: 2462 MHz									
2462.00	74.08	PK	H	28.22	1.83	0.00	104.13	N/A	N/A
2462.00	62.52	AV	H	28.22	1.83	0.00	92.57	N/A	N/A
2462.00	70.25	PK	V	28.22	1.83	0.00	100.30	N/A	N/A
2462.00	58.69	AV	V	28.22	1.83	0.00	88.74	N/A	N/A
2483.50	33.65	PK	H	28.27	1.84	0.00	63.76	74.00	10.24
2483.50	17.06	AV	H	28.27	1.84	0.00	47.17	54.00	6.83
4924.00	36.05	PK	H	33.15	3.27	25.65	46.82	74.00	27.18
4924.00	23.54	AV	H	33.15	3.27	25.65	34.31	54.00	19.69
7386.00	36.02	PK	H	36.20	4.51	25.79	50.94	74.00	23.06
7386.00	23.54	AV	H	36.20	4.51	25.79	38.46	54.00	15.54

802.11n ht20 Mode:

Frequency (MHz)	Receiver		Rx Antenna		Cable loss (dB)	Amplifier Gain (dB)	Corrected Amplitude (dB μ V/m)	Limit (dB μ V/m)	Margin (dB)
	Reading (dB μ V)	Detector	Polar (H/V)	Factor (dB/m)					
Low Channel: 2412 MHz									
2412.00	73.43	PK	H	28.12	1.81	0.00	103.36	N/A	N/A
2412.00	61.95	AV	H	28.12	1.81	0.00	91.88	N/A	N/A
2412.00	69.72	PK	V	28.12	1.81	0.00	99.65	N/A	N/A
2412.00	57.98	AV	V	28.12	1.81	0.00	87.91	N/A	N/A
2390.00	38.28	PK	H	28.08	1.80	0.00	68.16	74.00	5.84
2390.00	22.74	AV	H	28.08	1.80	0.00	52.62	54.00	1.38
4824.00	35.53	PK	H	32.95	3.19	25.62	46.05	74.00	27.95
4824.00	23.21	AV	H	32.95	3.19	25.62	33.73	54.00	20.27
7236.00	35.54	PK	H	35.81	4.77	25.64	50.48	74.00	23.52
7236.00	23.41	AV	H	35.81	4.77	25.64	38.35	54.00	15.65
Middle Channel: 2437 MHz									
2437.00	72.70	PK	H	28.17	1.82	0.00	102.69	N/A	N/A
2437.00	60.98	AV	H	28.17	1.82	0.00	90.97	N/A	N/A
2437.00	69.52	PK	V	28.17	1.82	0.00	99.51	N/A	N/A
2437.00	57.69	AV	V	28.17	1.82	0.00	87.68	N/A	N/A
4874.00	35.69	PK	H	33.05	3.26	25.65	46.35	74.00	27.65
4874.00	23.54	AV	H	33.05	3.26	25.65	34.20	54.00	19.80
7311.00	35.74	PK	H	36.01	4.64	25.71	50.68	74.00	23.32
7311.00	23.45	AV	H	36.01	4.64	25.71	38.39	54.00	15.61
High Channel: 2462 MHz									
2462.00	73.54	PK	H	28.22	1.83	0.00	103.59	N/A	N/A
2462.00	61.78	AV	H	28.22	1.83	0.00	91.83	N/A	N/A
2462.00	69.89	PK	V	28.22	1.83	0.00	99.94	N/A	N/A
2462.00	57.98	AV	V	28.22	1.83	0.00	88.03	N/A	N/A
2483.50	33.98	PK	H	28.27	1.84	0.00	64.09	74.00	9.91
2483.50	16.61	AV	H	28.27	1.84	0.00	46.72	54.00	7.28
4924.00	35.48	PK	H	33.15	3.27	25.65	46.25	74.00	27.75
4924.00	23.25	AV	H	33.15	3.27	25.65	34.02	54.00	19.98
7386.00	35.74	PK	H	36.20	4.51	25.79	50.66	74.00	23.34
7386.00	23.69	AV	H	36.20	4.51	25.79	38.61	54.00	15.39

802.11n ht40 Mode:

Frequency (MHz)	Receiver		Rx Antenna		Cable loss (dB)	Amplifier Gain (dB)	Corrected Amplitude (dB μ V/m)	Limit (dB μ V/m)	Margin (dB)
	Reading (dB μ V)	Detector	Polar (H/V)	Factor (dB/m)					
Low Channel: 2422 MHz									
2422.00	70.07	PK	H	28.14	1.81	0.00	100.02	N/A	N/A
2422.00	57.58	AV	H	28.14	1.81	0.00	87.53	N/A	N/A
2422.00	67.26	PK	V	28.14	1.81	0.00	97.21	N/A	N/A
2422.00	55.63	AV	V	28.14	1.81	0.00	85.58	N/A	N/A
2390.00	36.94	PK	H	28.08	1.80	0.00	66.82	74.00	7.18
2390.00	22.02	AV	H	28.08	1.80	0.00	51.90	54.00	2.10
4844.00	35.69	PK	H	32.99	3.22	25.63	46.27	74.00	27.73
4844.00	23.41	AV	H	32.99	3.22	25.63	33.99	54.00	20.01
7266.00	36.02	PK	H	35.89	4.72	25.67	50.96	74.00	23.04
7266.00	23.87	AV	H	35.89	4.72	25.67	38.81	54.00	15.19
Middle Channel: 2437 MHz									
2437.00	72.78	PK	H	28.17	1.82	0.00	102.77	N/A	N/A
2437.00	60.87	AV	H	28.17	1.82	0.00	90.86	N/A	N/A
2437.00	70.25	PK	V	28.17	1.82	0.00	100.24	N/A	N/A
2437.00	58.36	AV	V	28.17	1.82	0.00	88.35	N/A	N/A
4874.00	36.05	PK	H	33.05	3.26	25.65	46.71	74.00	27.29
4874.00	23.47	AV	H	33.05	3.26	25.65	34.13	54.00	19.87
7311.00	35.55	PK	H	36.01	4.64	25.71	50.49	74.00	23.51
7311.00	23.41	AV	H	36.01	4.64	25.71	38.35	54.00	15.65
High Channel: 2452 MHz									
2452.00	73.21	PK	H	28.20	1.83	0.00	103.24	N/A	N/A
2452.00	61.23	AV	H	28.20	1.83	0.00	91.26	N/A	N/A
2452.00	70.56	PK	V	28.20	1.83	0.00	100.59	N/A	N/A
2452.00	58.41	AV	V	28.20	1.83	0.00	88.44	N/A	N/A
2483.50	37.56	PK	H	28.27	1.84	0.00	67.67	74.00	6.33
2483.50	19.28	AV	H	28.27	1.84	0.00	49.39	54.00	4.61
4904.00	35.45	PK	H	33.11	3.30	25.67	46.19	74.00	27.81
4904.00	23.25	AV	H	33.11	3.30	25.67	33.99	54.00	20.01
7356.00	35.77	PK	H	36.13	4.56	25.76	50.70	74.00	23.30
7356.00	23.41	AV	H	36.13	4.56	25.76	38.34	54.00	15.66

Test plots(802.11n ht40 low channel was the worst)

Horizontal:

Fundamental
Test with Band
Rejection Filter

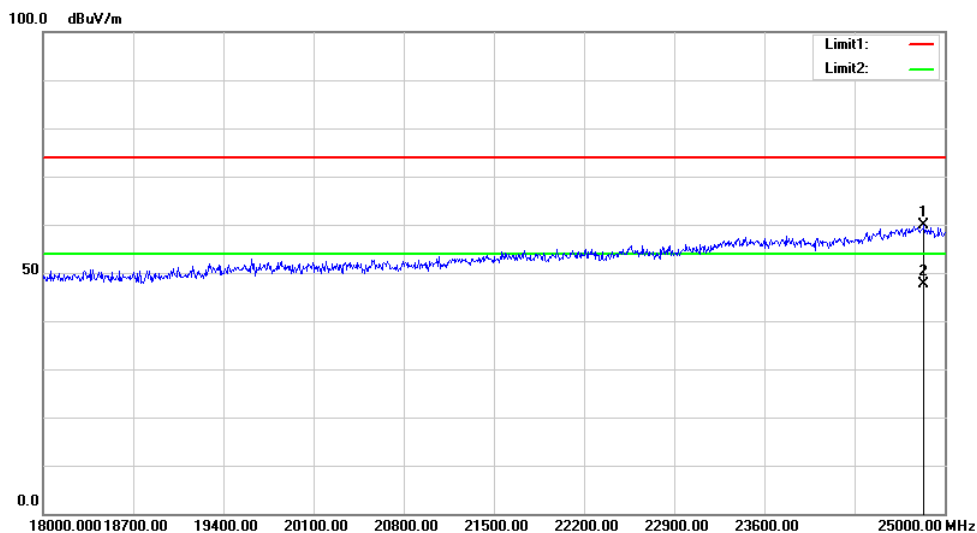
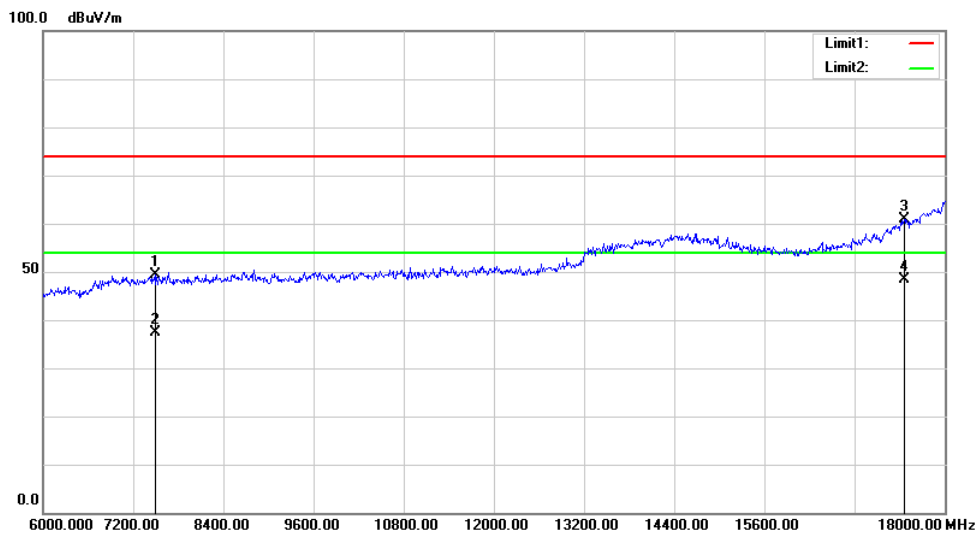
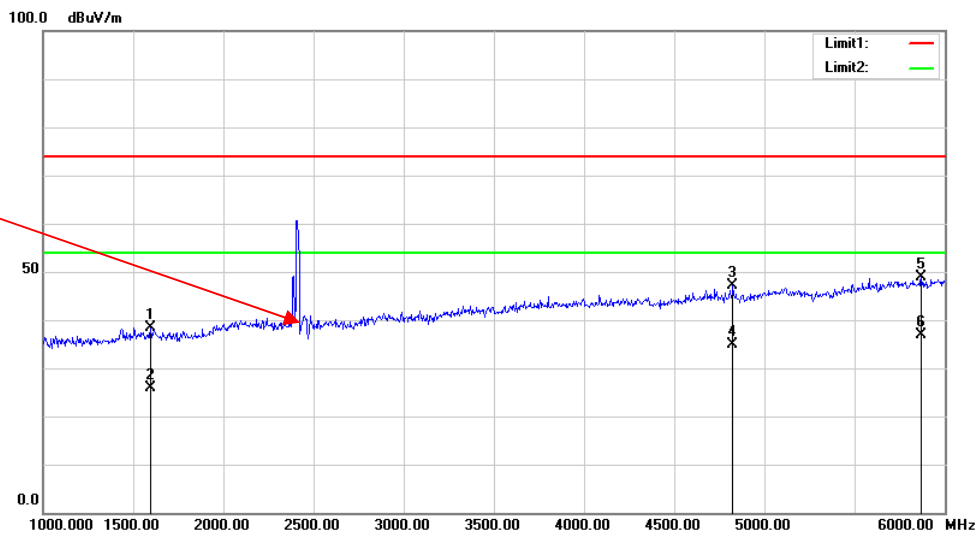

Vertical:

Fundamental
Test with Band
Rejection Filter

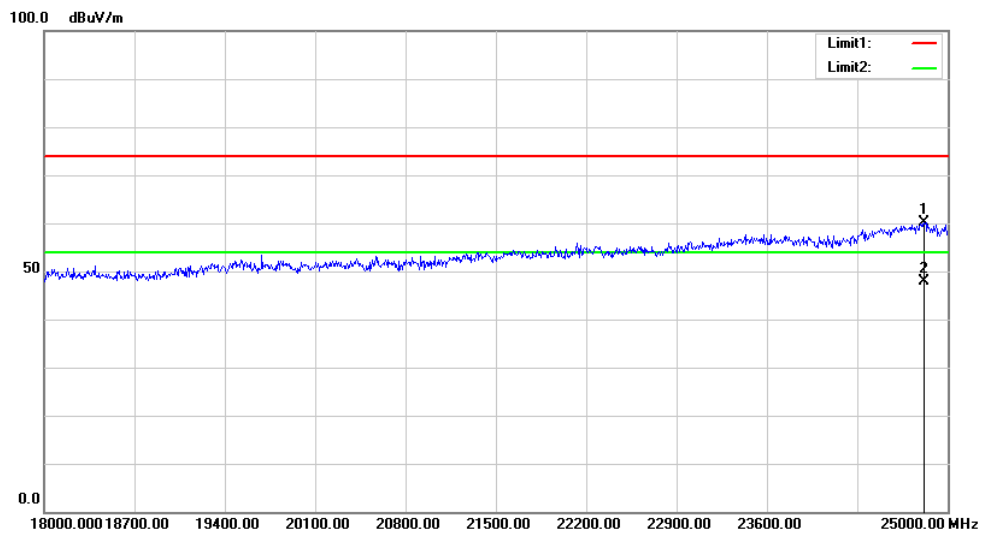
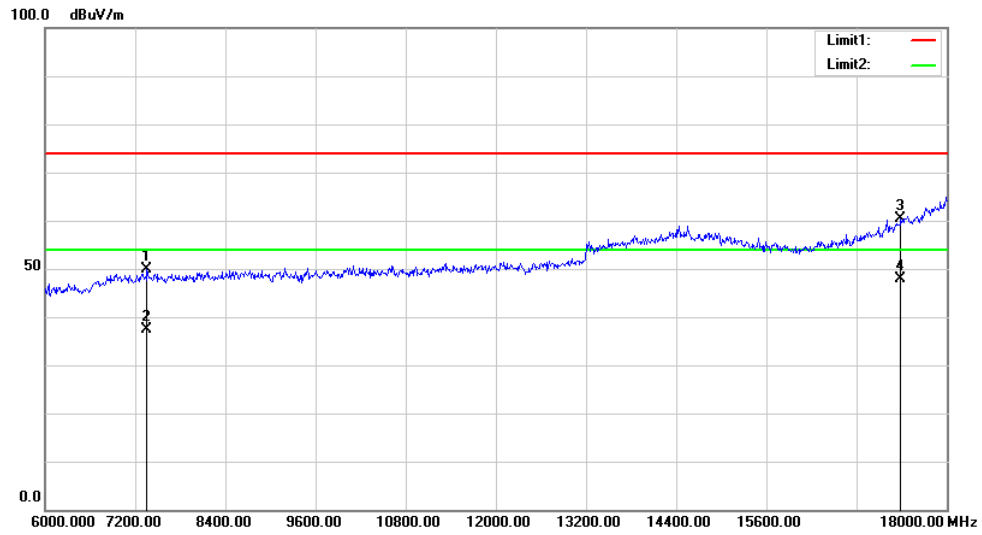
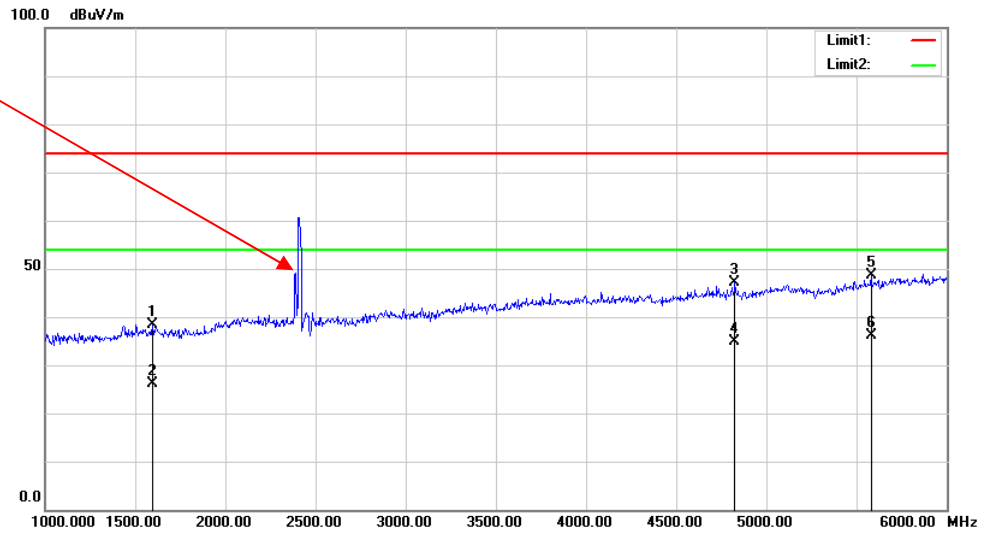

FCC §15.247(a) (2)–6 dB EMISSION BANDWIDTH

Applicable Standard

According to FCC §15.247(a) (2)

Systems using digital modulation techniques may operate in the 902–928 MHz, 2400–2483.5 MHz, and 5725–5850 MHz bands. The minimum 6 dB bandwidth shall be at least 500 kHz.

Test Procedure

- a) Set RBW = 100 kHz.
- b) Set the video bandwidth (VBW) $\geq 3 \times$ RBW.
- c) Detector = Peak.
- d) Trace mode = max hold.
- e) Sweep = auto couple.
- f) Allow the trace to stabilize.
- g) Measure the maximum width of the emission that is constrained by the frequencies associated with the two outermost amplitude points (upper and lower frequencies) that are attenuated by 6 dB relative to the maximum level measured in the fundamental emission.

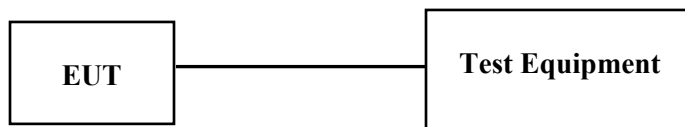

Test Equipment List and Details

Manufacturer	Description	Model	Serial Number	Calibration Date	Calibration Due Date
R&S	Spectrum Analyzer	FSU 26	200256	2020-07-07	2021-07-07
yzjingcheng	Coaxial Cable	KTRFBU-141-50	41005011	Each time	N/A

* **Statement of Traceability:** Bay Area Compliance Laboratories Corp. (Dongguan) attests that all calibrations have been performed, traceable to National Primary Standards and International System of Units (SI).

Test Data

Environmental Conditions

Temperature:	26.8 °C
Relative Humidity:	41 %
ATM Pressure:	101.2 kPa
Tester:	James Chen
Test Date:	2020-11-20

Test Mode: Transmitting

Test Result: Compliance. Please refer to the following table and plots.

Test mode	Channel	Frequency (MHz)	6 dB Bandwidth (MHz)	Limit (MHz)
802.11b	Low	2412	8.640	≥ 0.5
	Middle	2437	10.00	≥ 0.5
	High	2462	9.04	≥ 0.5
802.11g	Low	2412	16.400	≥ 0.5
	Middle	2437	16.480	≥ 0.5
	High	2462	16.320	≥ 0.5
802.11n ht20	Low	2412	17.440	≥ 0.5
	Middle	2437	17.680	≥ 0.5
	High	2462	17.440	≥ 0.5
802.11n ht40	Low	2422	35.360	≥ 0.5
	Middle	2437	36.000	≥ 0.5
	High	2452	35.360	≥ 0.5

802.11b Low Channel

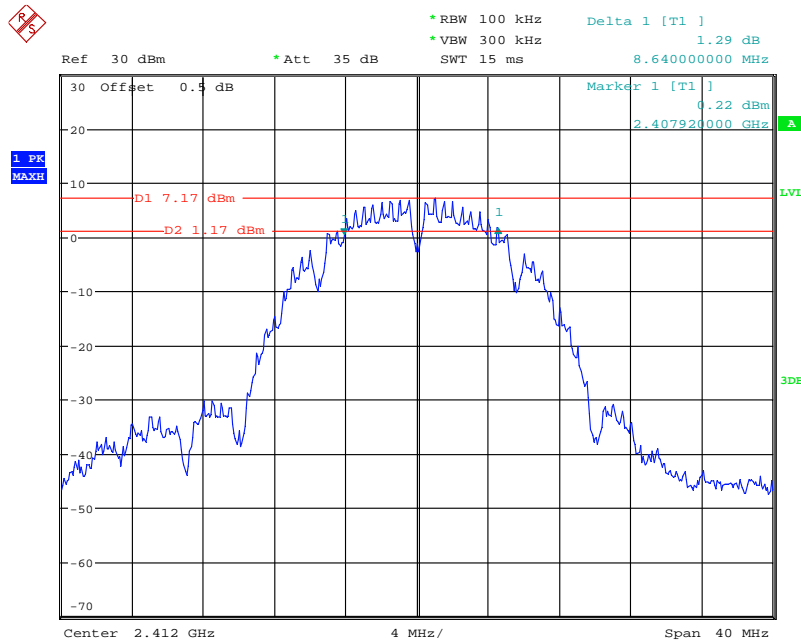

Date: 20.NOV.2020 18:30:25

802.11b Middle Channel

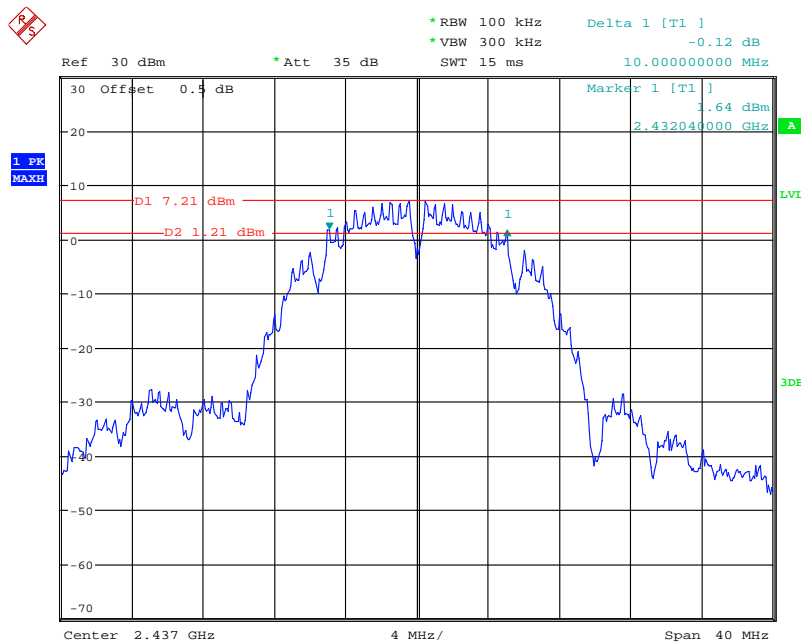

Date: 20.NOV.2020 18:34:01

802.11b High Channel

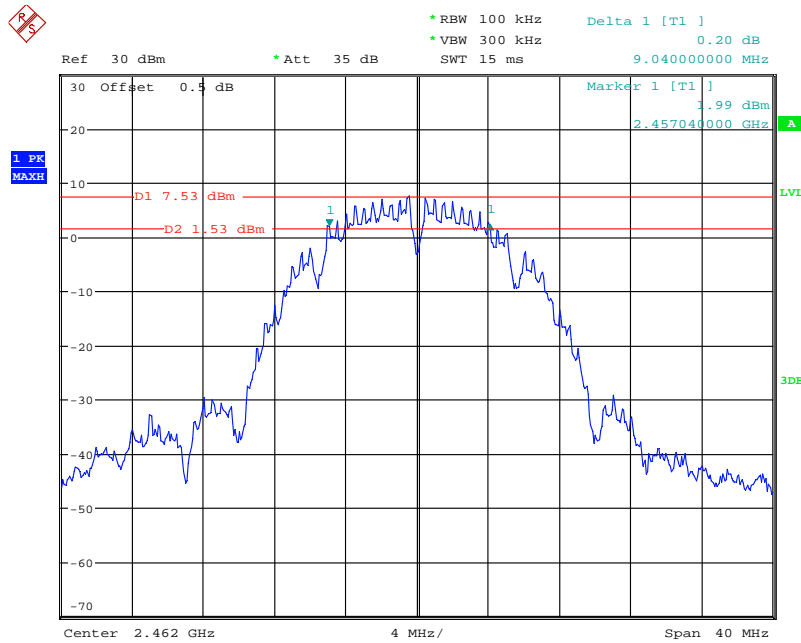

Date: 20.NOV.2020 18:32:32

802.11g Low Channel

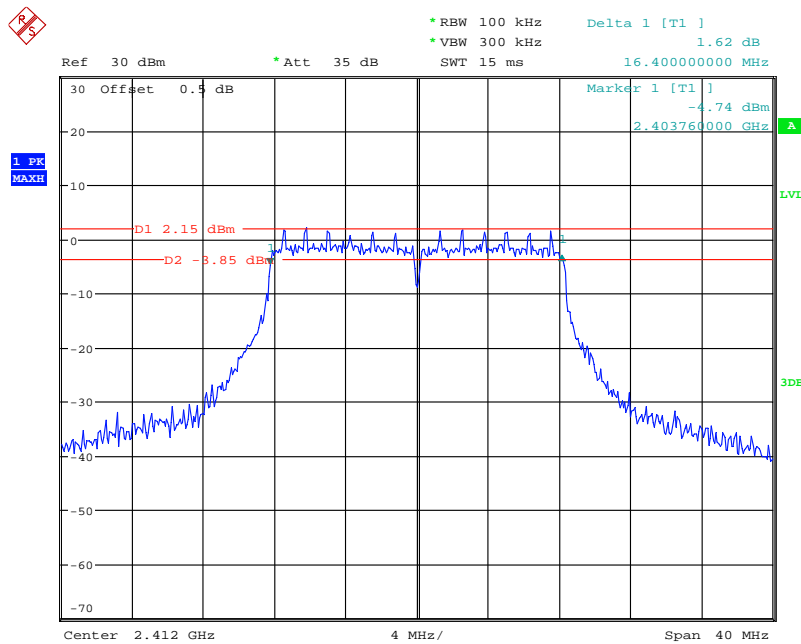

Date: 20.NOV.2020 18:35:31

802.11g Middle Channel

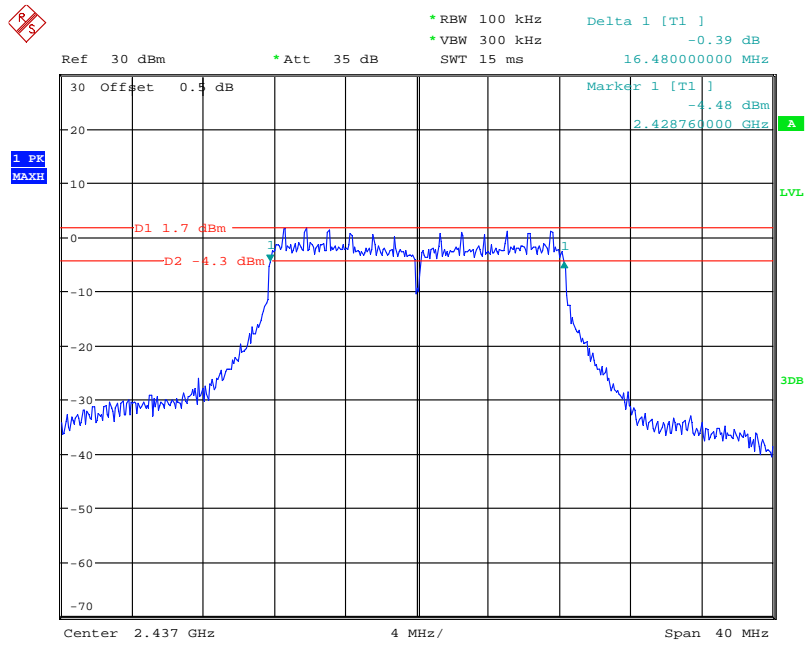

Date: 20.NOV.2020 18:37:22

802.11g High Channel

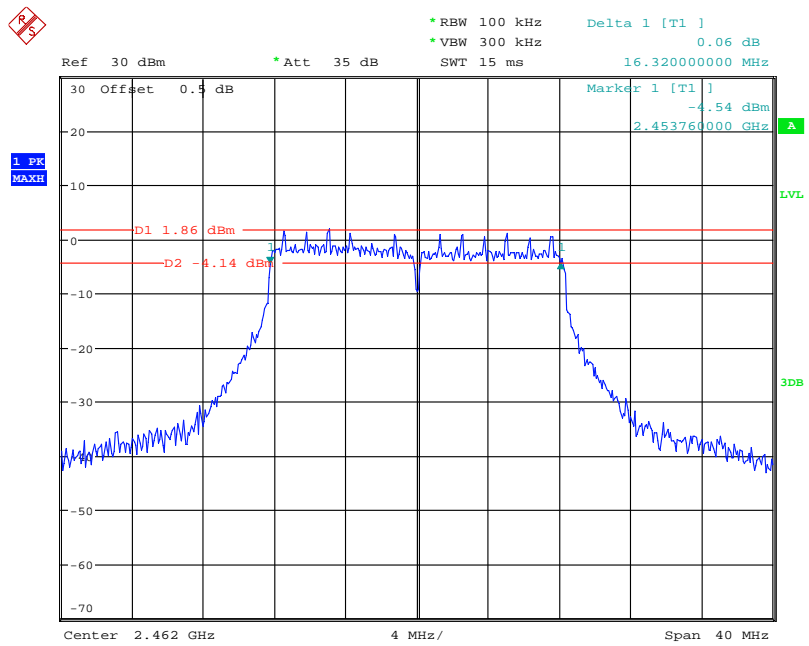

Date: 20.NOV.2020 18:39:10

802.11n ht20 Low Channel

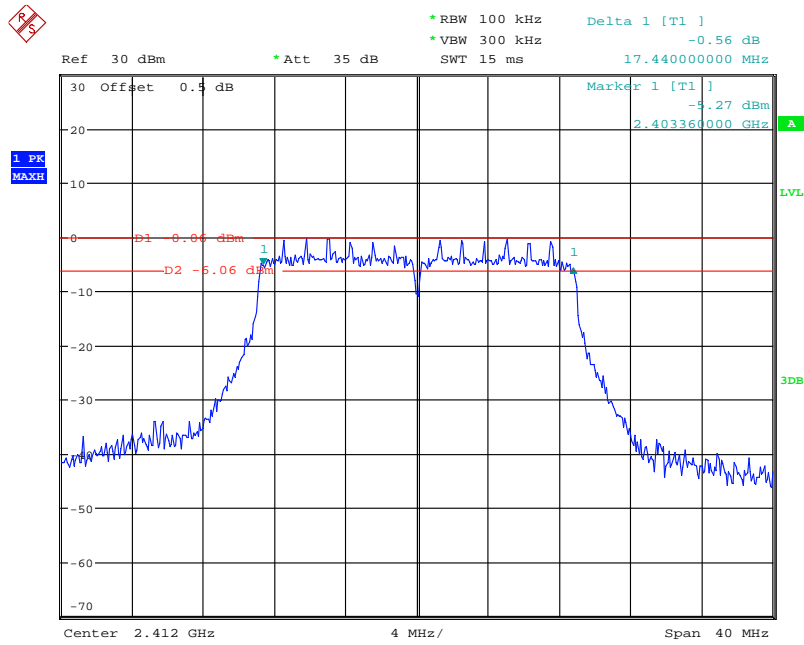

Date: 20.NOV.2020 18:41:12

802.11n ht20 Middle Channel

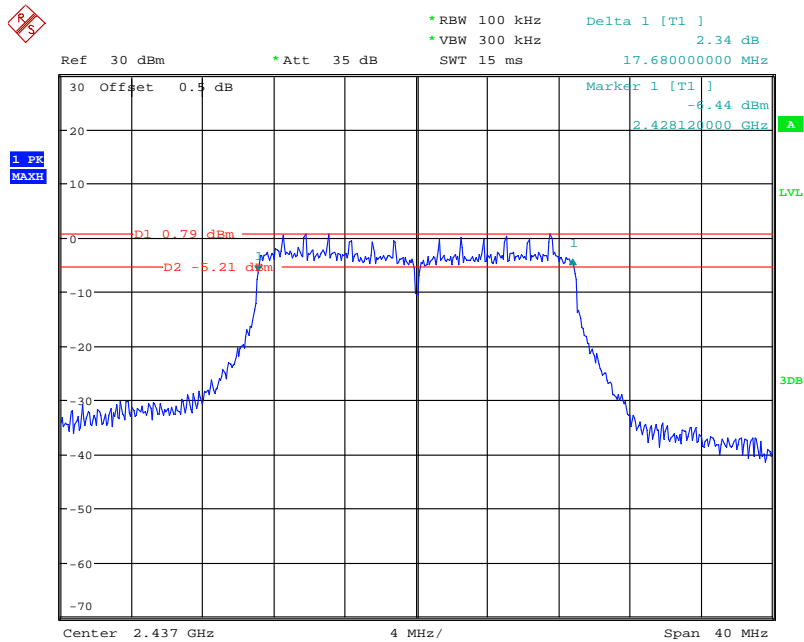

Date: 20.NOV.2020 18:42:59

802.11n ht20 High Channel

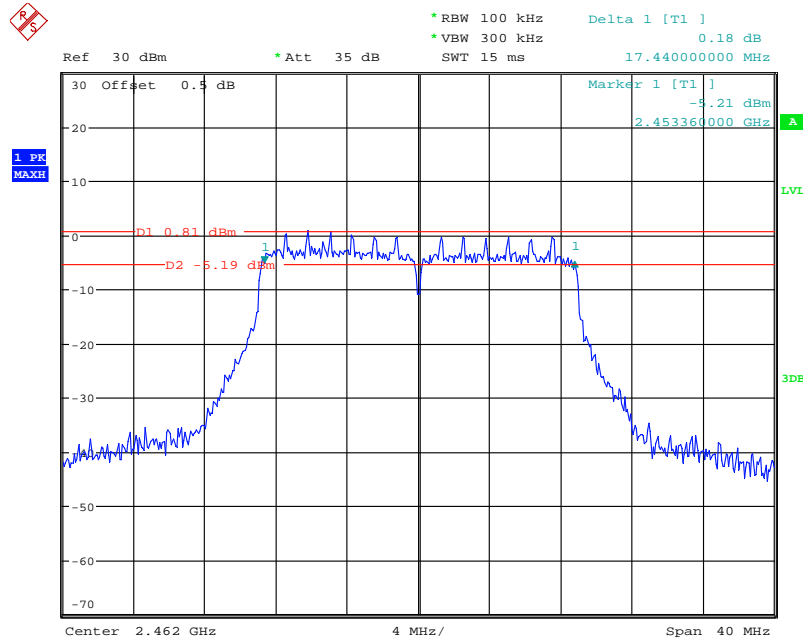

Date: 20.NOV.2020 18:45:00

802.11n ht40 Low Channel

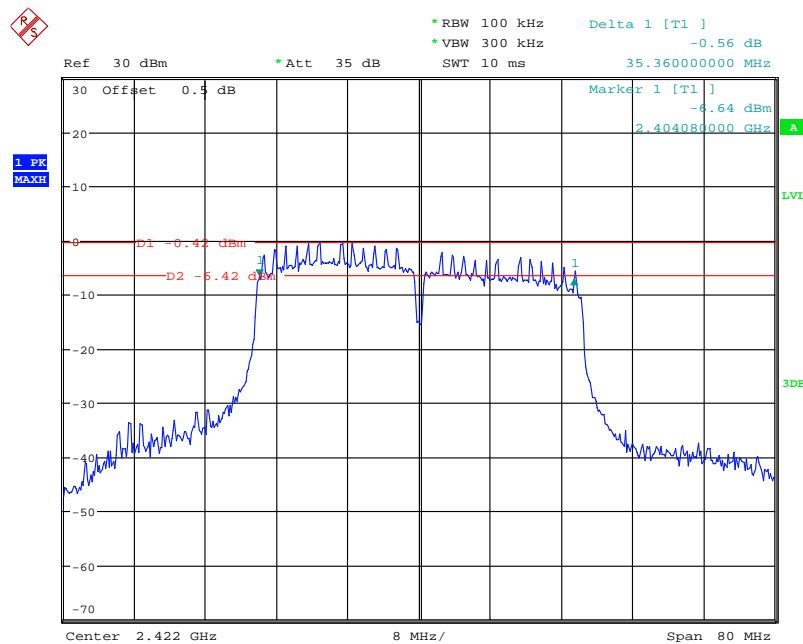

Date: 20.NOV.2020 18:47:10

802.11n ht40 Middle Channel

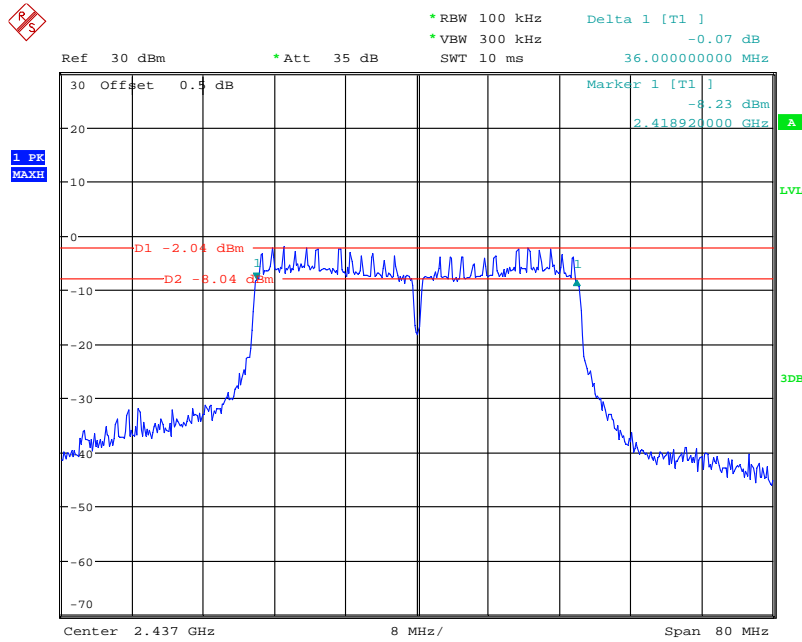

Date: 20.NOV.2020 18:49:32

802.11n ht40 High Channel

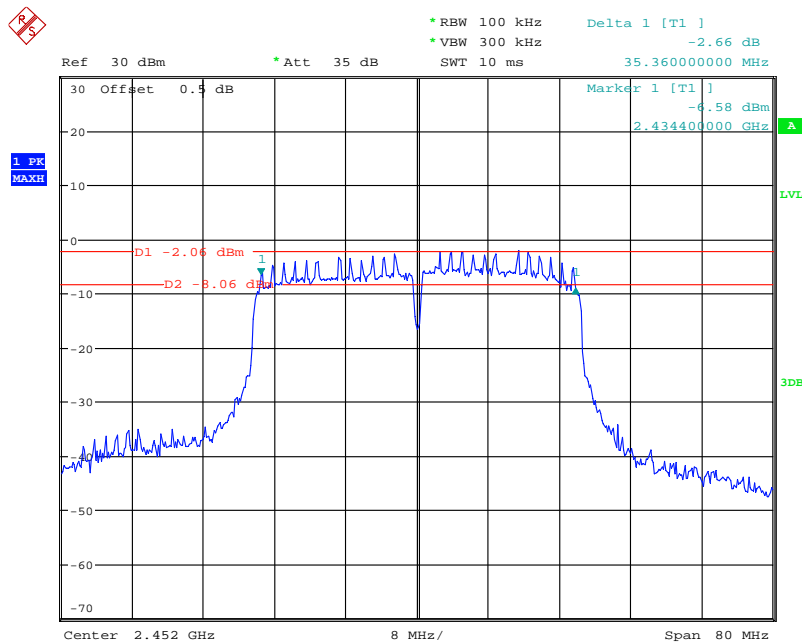

Date: 20.NOV.2020 18:52:02

FCC §15.247(b) (3) - MAXIMUM PEAK CONDUCTED OUTPUT POWER

Applicable Standard

According to FCC §15.247(b) (3), for systems using digital modulation in the 902-928 MHz, 2400-2483.5 MHz, and 5725-5850 MHz bands: 1 Watt. As an alternative to a peak power measurement, compliance with the one Watt limit can be based on a measurement of the maximum conducted output power. Maximum Conducted Output Power is defined as the total transmit power delivered to all antennas and antenna elements averaged across all symbols in the signaling alphabet when the transmitter is operating at its maximum power control level. Power must be summed across all antennas and antenna elements. The average must not include any time intervals during which the transmitter is off or is transmitting at a reduced power level. If multiple modes of operation are possible (e.g., alternative modulation methods), the maximum conducted output power is the highest total transmit power occurring in any mode.

Test Procedure

1. Place the EUT on a bench and set it in transmitting mode.
2. Remove the antenna from the EUT and then connect a low loss RF cable from the antenna port to test equipment.
3. Add a correction factor to the display.
4. Set the power meter to test average output power, record the result as average power.

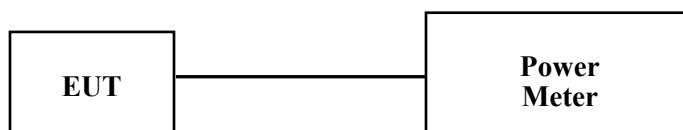

Test Equipment List and Details

Manufacturer	Description	Model	Serial Number	Calibration Date	Calibration Due Date
E-Microwave	Coaxial Attenuators	EMCA10-5RN-6	OE01203239	Each time	N/A
yzjingcheng	Coaxial Cable	KTRFBU-141-50	41005011	Each time	N/A
Agilent	USB Wideband Power Sensor	U2021XA	MY54080014	2020-09-12	2021-09-12

* **Statement of Traceability:** Bay Area Compliance Laboratories Corp. (Dongguan) attests that all calibrations have been performed, traceable to National Primary Standards and International System of Units (SI).

Test Data**Environmental Conditions**

Temperature:	26.8 °C
Relative Humidity:	41 %
ATM Pressure:	101.2kPa
Tester:	James Chen
Test Date:	2020-11-20

Test Mode: Transmitting

Test Result: Compliance. Please refer to the following table.

Test mode	Frequency (MHz)	Conducted Peak Output Power (dBm)	Conducted Average Output Power (dBm)	Limit (dBm)
802.11b	2412	18.54	15.89	30
	2437	18.48	15.69	30
	2462	18.69	15.80	30
802.11g	2412	21.42	13.31	30
	2437	22.12	12.76	30
	2462	21.92	12.65	30
802.11n ht20	2412	20.96	12.15	30
	2437	21.61	11.79	30
	2462	21.14	11.59	30
802.11n ht40	2422	22.78	12.02	30
	2437	22.26	11.56	30
	2452	22.23	12.01	30

Note: The data above was tested in conducted mode.

FCC §15.247(d)– 100 kHz BANDWIDTH OF FREQUENCY BAND EDGE

Applicable Standard

According to FCC§15.247(d):In any 100 kHz bandwidth outside the frequency band in which the spread spectrum or digitally modulated intentional radiator is operating, the radio frequency power that is produced by the intentional radiator shall be at least 20 dB below that in the 100 kHz bandwidth within the band that contains the highest level of the desired power, based on either an RF conducted or a radiated measurement, provided the transmitter demonstrates compliance with the peak conducted power limits. If the transmitter complies with the conducted power limits based on the use of RMS averaging over a time interval, as permitted under paragraph (b)(3) of this section, the attenuation required under this paragraph shall be 30 dB instead of 20 dB. Attenuation below the general limits specified in §15.209(a) is not required. In addition, radiated emissions which fall in the restricted bands, as defined in §15.205(a), must also comply with the radiated emission limits specified in §15.209(a) (see §15.205(c)).

Test Procedure

1. Check the calibration of the measuring instrument using either an internal calibrator or a known signal from an external generator.
2. Position the EUT without connection to measurement instrument. Turn on the EUT and connect its antenna terminal to measurement instrument via a low loss cable. Then set it to any one measured frequency within its operating range, and make sure the instrument is operated in its linear range.
3. Set RBW to 100 kHz and VBW of spectrum analyzer to 300 kHz with a convenient frequency span including 100 kHz bandwidth from band edge.
4. Measure the highest amplitude appearing on spectral display and set it as a reference level. Plot the graph with marking the highest point and edge frequency.
5. Repeat above procedures until all measured frequencies were complete.

Test Equipment List and Details

Manufacturer	Description	Model	Serial Number	Calibration Date	Calibration Due Date
R&S	Spectrum Analyzer	FSU 26	200256	2020-07-07	2021-07-07
yzjingcheng	Coaxial Cable	KTRFBU-141-50	41005011	Each time	N/A

* **Statement of Traceability:** Bay Area Compliance Laboratories Corp. (Dongguan) attests that all calibrations have been performed, traceable to National Primary Standards and International System of Units (SI).

Test Data

Environmental Conditions

Temperature:	26.8 °C
Relative Humidity:	41 %
ATM Pressure:	101.2kPa
Tester:	James Chen
Test Date:	2020-11-20

Test mode: Transmitting

Test Result: Compliance. Please refer to following plots.

802.11b: Band Edge, Left Side

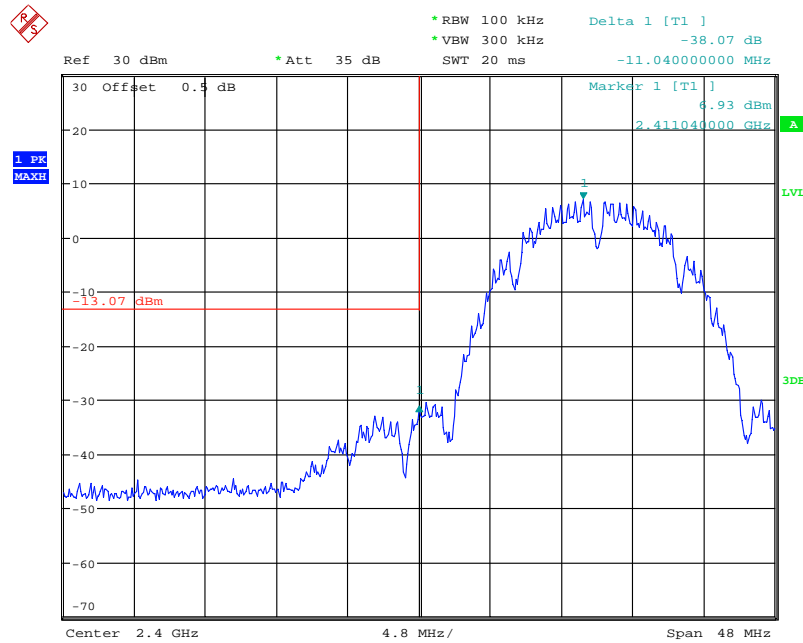

Date: 20.NOV.2020 18:31:20

802.11b: Band Edge, Right Side

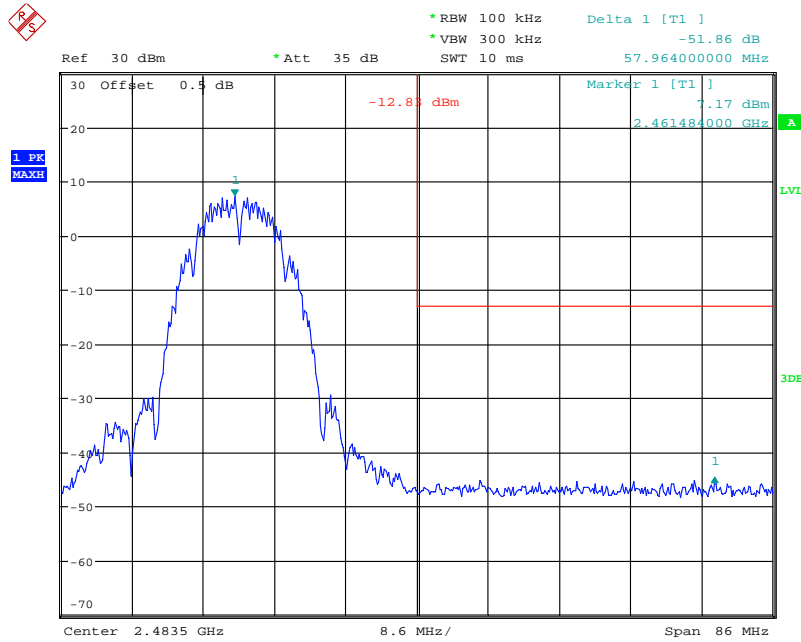

Date: 20.NOV.2020 18:33:27

802.11g: Band Edge, Left Side

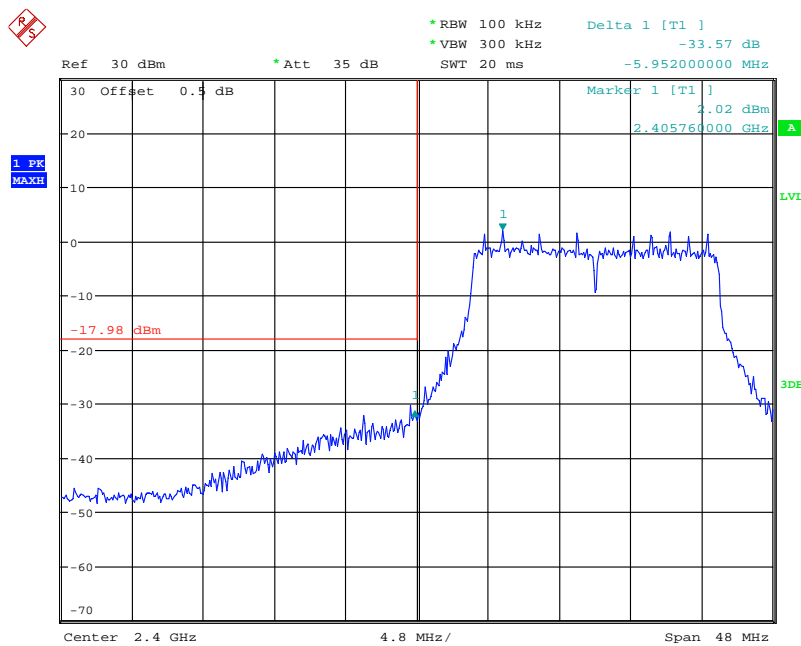

Date: 20.NOV.2020 18:36:46

802.11g: Band Edge, Right Side

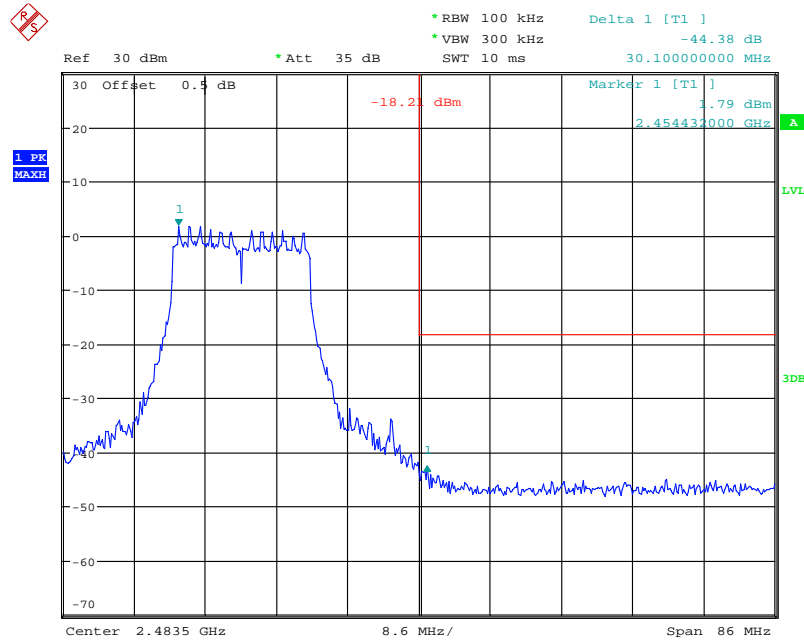

Date: 20.NOV.2020 18:40:19

802.11n ht20 Band Edge, Left Side

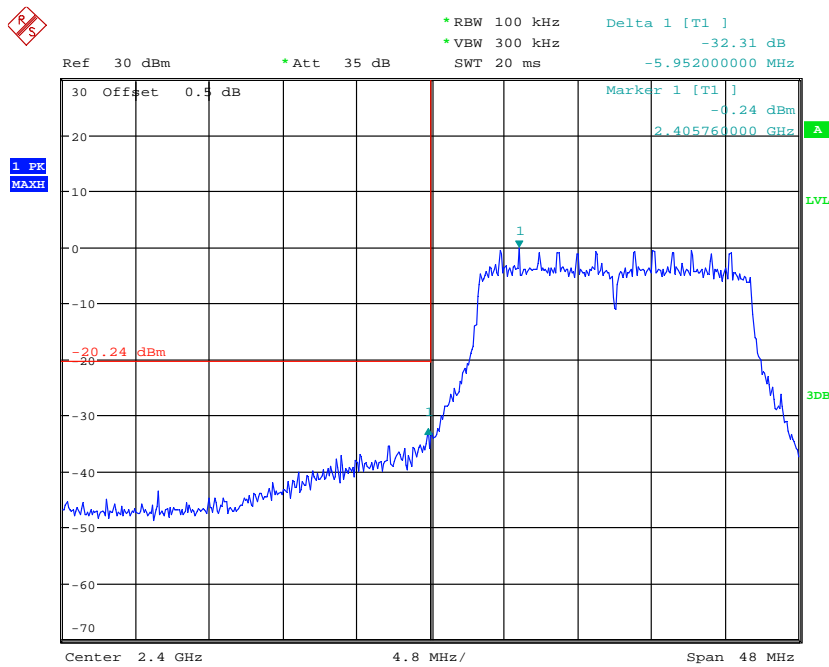

Date: 20.NOV.2020 18:42:23

802.11n ht20 Band Edge, Right Side

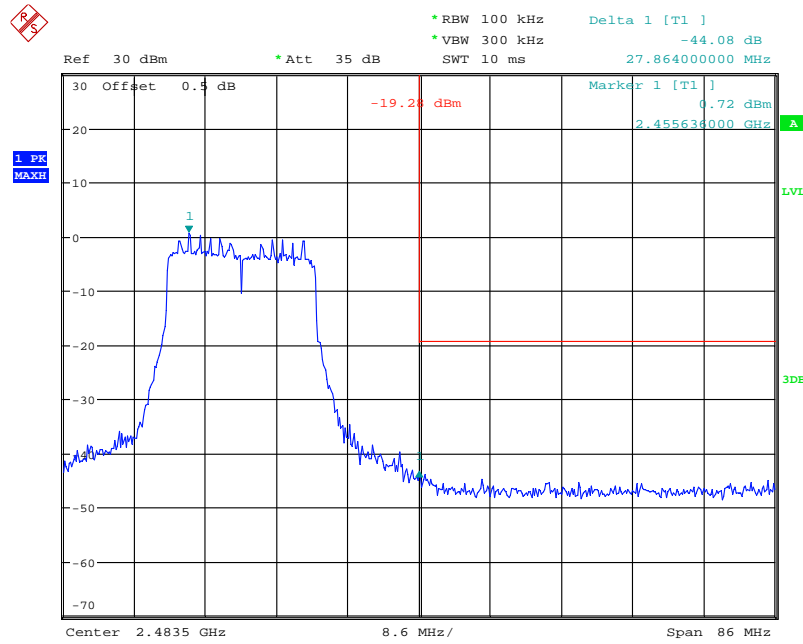

Date: 20.NOV.2020 18:46:07

802.11n ht40 Band Edge, Left Side

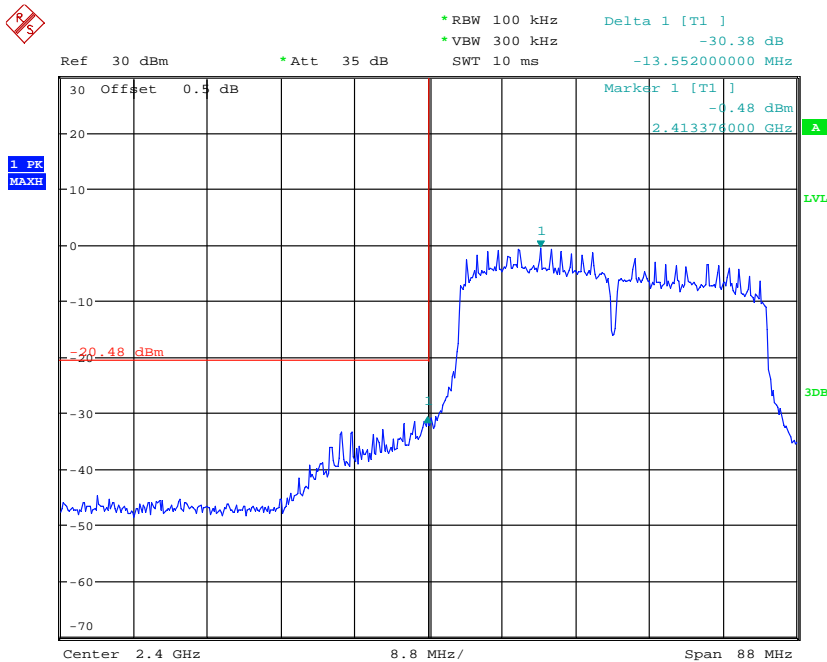

Date: 20.NOV.2020 18:48:50

802.11n ht40 Band Edge, Right Side

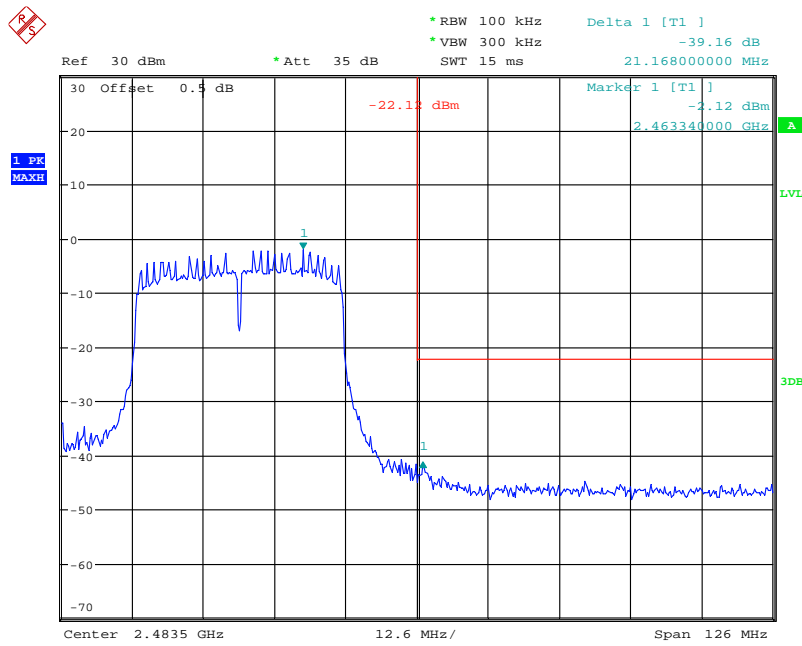

Date: 20.NOV.2020 18:53:43

FCC §15.247(e) - POWER SPECTRAL DENSITY

Applicable Standard

For digitally modulated systems, the power spectral density conducted from the intentional radiator to the antenna shall not be greater than 8 dBm in any 3 kHz band during any time interval of continuous transmission. This power spectral density shall be determined in accordance with the provisions of paragraph (b) of this section. The same method of determining the conducted output power shall be used to determine the power spectral density.

Test Procedure

1. Check the calibration of the measuring instrument using either an internal calibrator or a known signal from an external generator.
2. Position the EUT was set without connection to measurement instrument. Turn on the EUT and connect its antenna terminal to measurement instrument via a low loss cable. Then set it to any one measured frequency within its operating range, and make sure the instrument is operated in its linear range.
3. Set the RBW = 3 kHz, VBW = 10 kHz, Set the span to 1.5 times the DTS bandwidth.
4. Use the peak marker function to determine the maximum amplitude level.

Test Equipment List and Details

Manufacturer	Description	Model	Serial Number	Calibration Date	Calibration Due Date
R&S	Spectrum Analyzer	FSU 26	200256	2020-07-07	2021-07-07
yzjingcheng	Coaxial Cable	KTRFBU-141-50	41005011	Each time	N/A

* **Statement of Traceability:** Bay Area Compliance Laboratories Corp. (Dongguan) attests that all calibrations have been performed, traceable to National Primary Standards and International System of Units (SI).

Test Data

Environmental Conditions

Temperature:	26.8 °C
Relative Humidity:	41 %
ATM Pressure:	101.2 kPa
Tester:	James Chen
Test Date:	2020-11-20

Test Result: Compliance. Please refer to the following table and plots

Test Mode: Transmitting

Test mode	Frequency (MHz)	Power Spectral Density (dBm/3kHz)	Limit (dBm/3kHz)
802.11b	2412	-7.05	≤8
	2437	-7.61	≤8
	2462	-5.97	≤8
802.11g	2412	-11.45	≤8
	2437	-12.75	≤8
	2462	-12.44	≤8
802.11n ht20	2412	-14.28	≤8
	2437	-13.83	≤8
	2462	-14.15	≤8
802.11n ht40	2422	-14.20	≤8
	2437	-14.46	≤8
	2452	-16.82	≤8

Power Spectral Density, 802.11b Low Channel

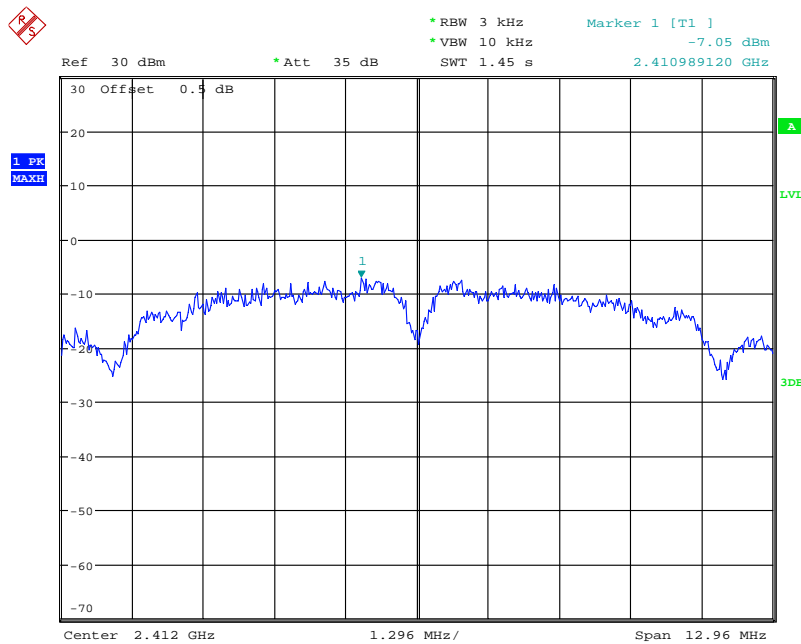

Date: 20.NOV.2020 18:31:03

Power Spectral Density, 802.11b Middle Channel

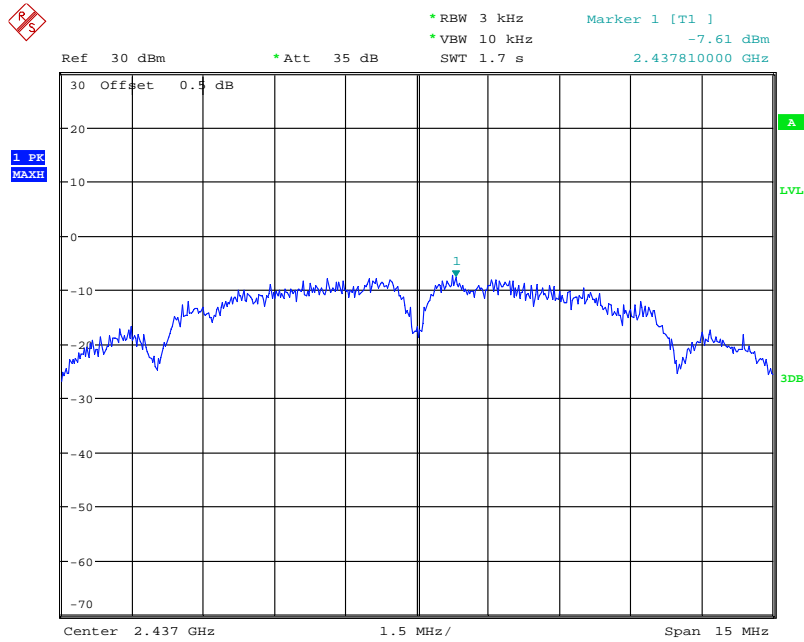

Date: 20.NOV.2020 18:34:41

Power Spectral Density, 802.11b High Channel

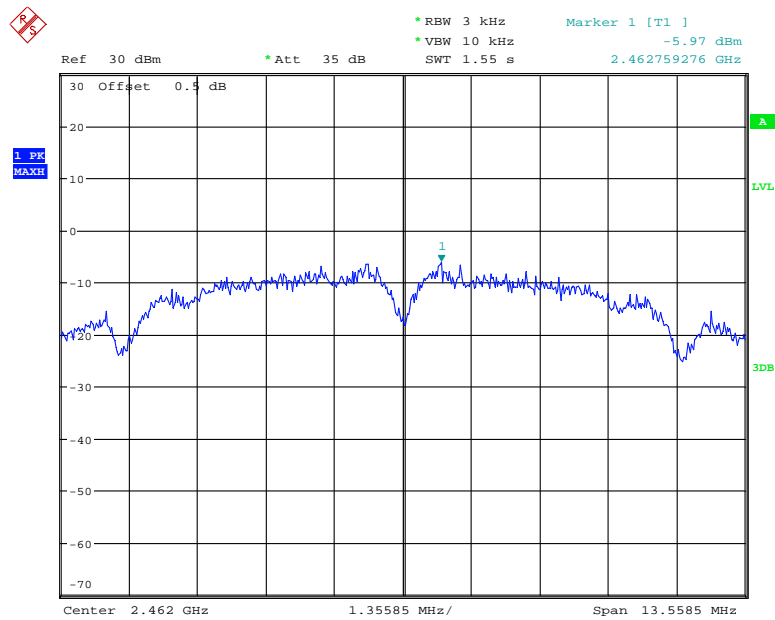

Date: 20.NOV.2020 18:33:13

Power Spectral Density, 802.11g Low Channel

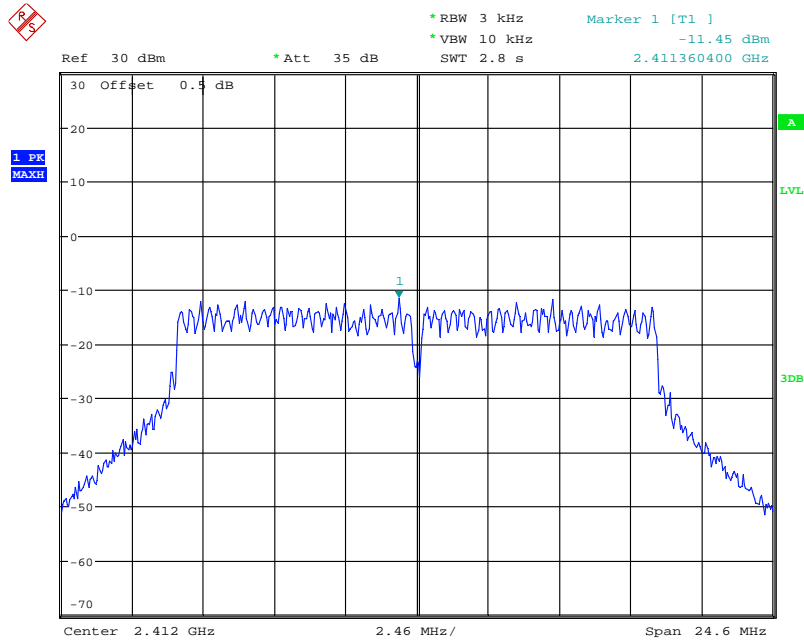

Date: 20.NOV.2020 18:36:33

Power Spectral Density, 802.11g Middle Channel

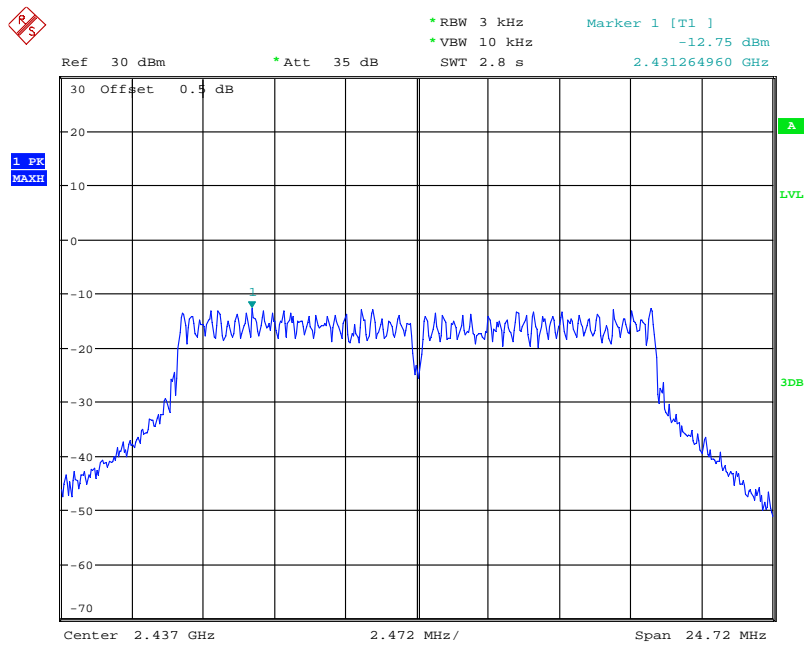

Date: 20.NOV.2020 18:38:14

Power Spectral Density, 802.11g High Channel

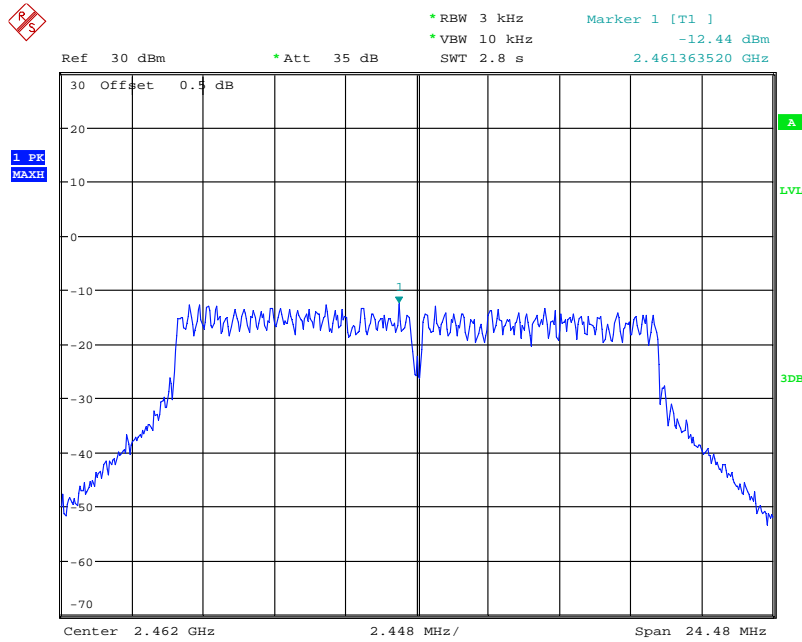

Date: 20.NOV.2020 18:40:02

Power Spectral Density, 802.11n ht20 Low Channel

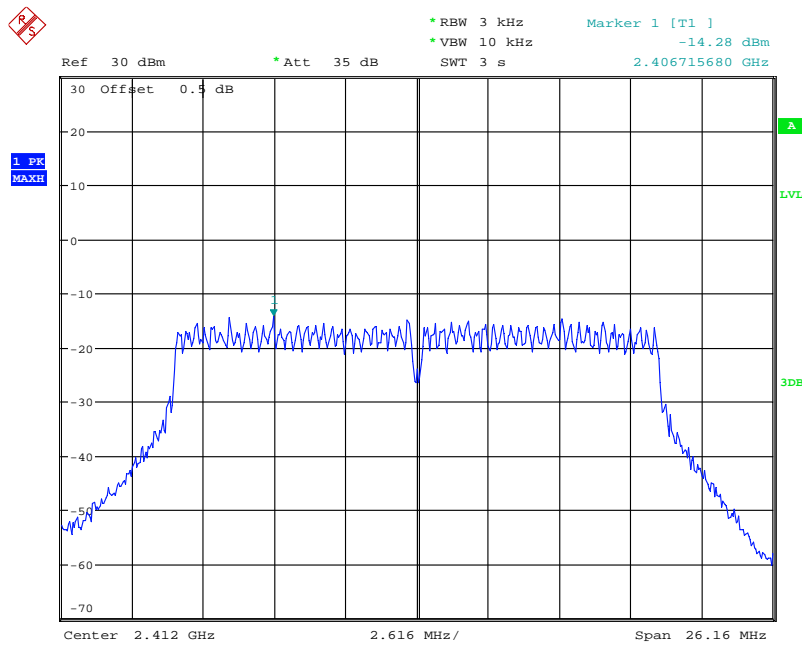

Date: 20.NOV.2020 18:42:06

Power Spectral Density, 802.11n ht20 Middle Channel

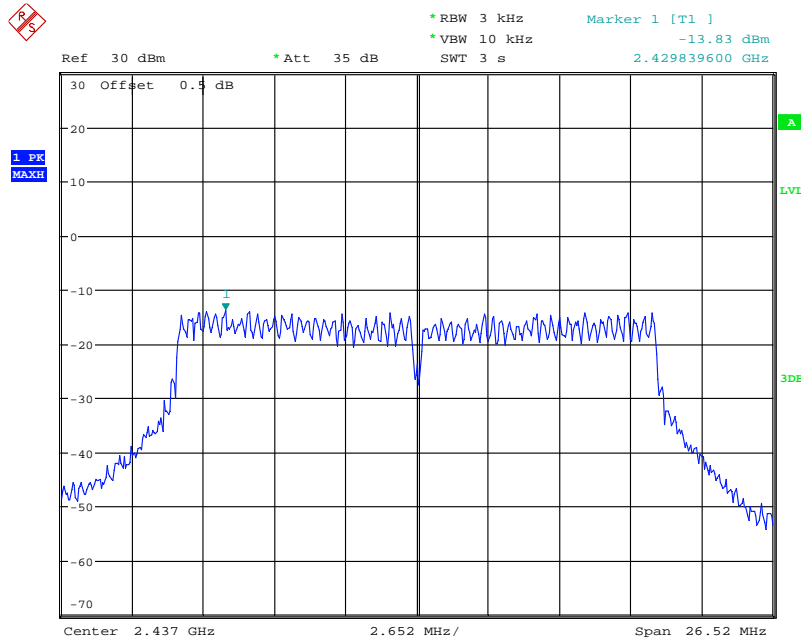

Date: 20.NOV.2020 18:44:04

Power Spectral Density, 802.11n ht20 High Channel

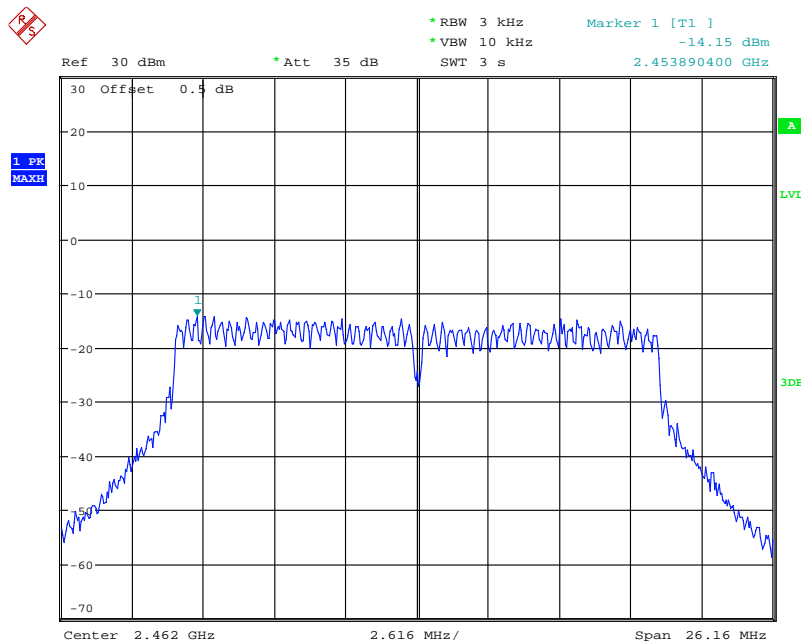

Date: 20.NOV.2020 18:45:54

Power Spectral Density, 802.11n ht40 Low Channel

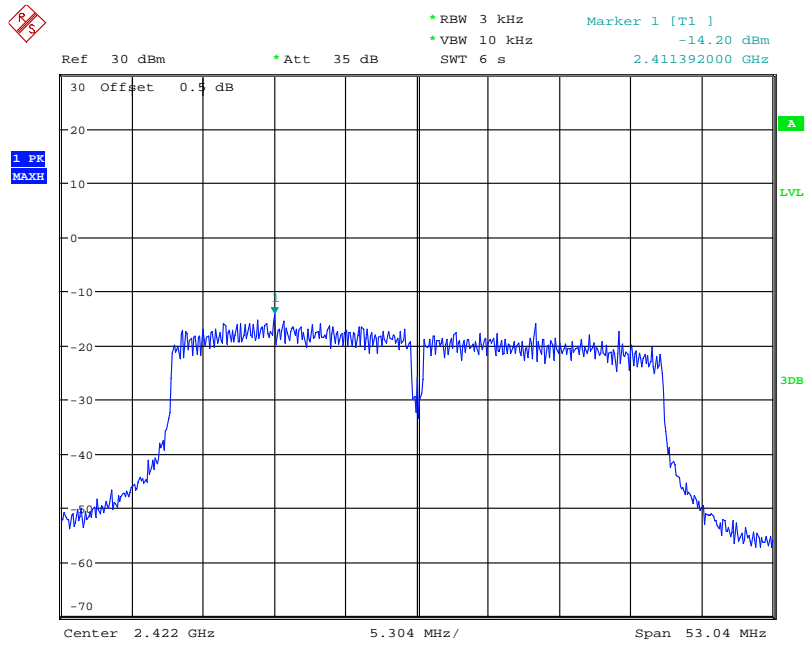

Date: 20.NOV.2020 18:48:33

Power Spectral Density, 802.11n ht40 Middle Channel

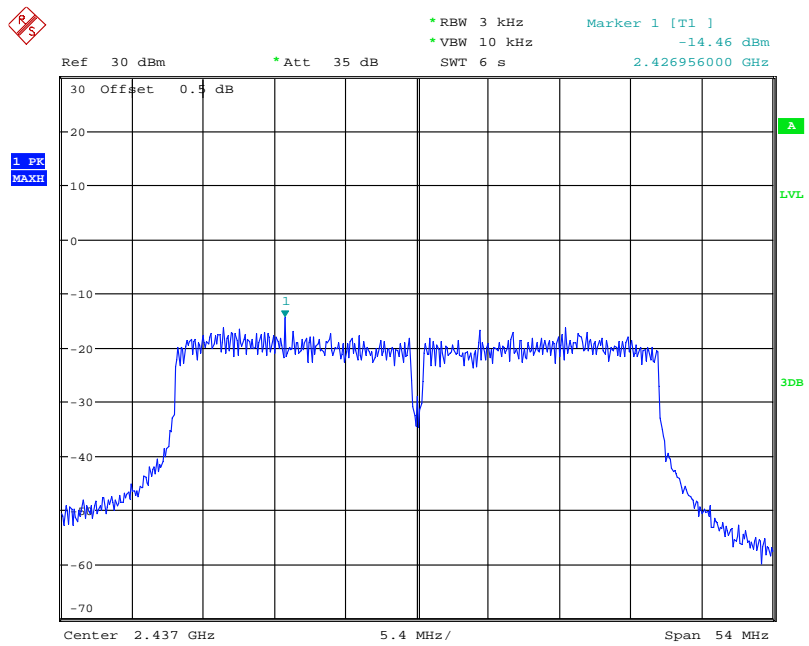

Date: 20.NOV.2020 18:51:16

Power Spectral Density, 802.11n ht40 High Channel

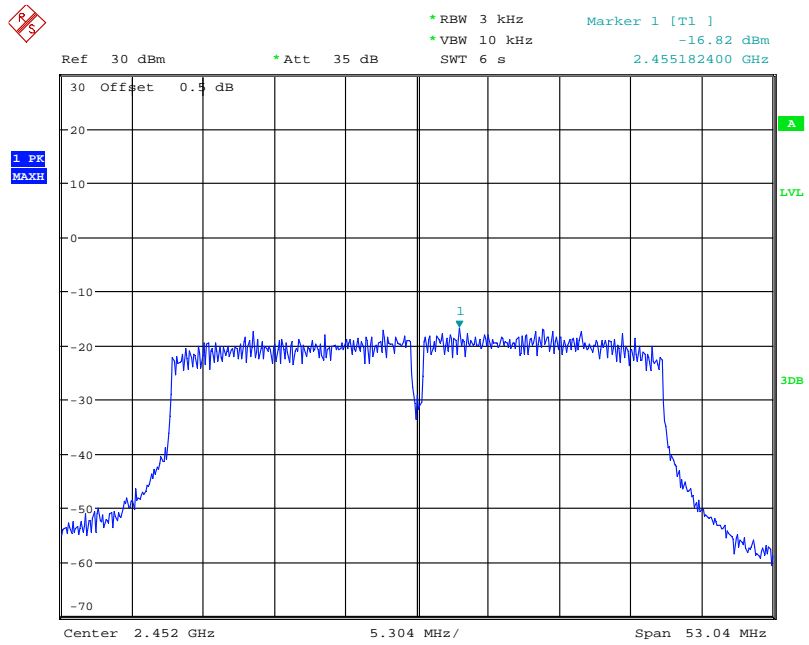

Date: 20.NOV.2020 18:53:26

***** END OF REPORT *****