

# TEST REPORT

**Reference No.**..... : WTS16S0243054-5E  
**FCC ID** ..... : 2AC88-E1  
**Applicant**..... : HONGKONG UCLOUDLINK NETWORK TECHNOLOGY LIMITED  
**Address**..... : Unit D.16F.chenknang plaza 250 Hennessy Road,Wanchai  
Hongkong  
**Manufacturer** ..... : Shenzhen Ukelink New Technology Co.,Ltd  
**Address**..... : 3 Floor, Building A, Unit 1, the Software industry base, Xuefuroad,  
Nanshan district, Shenzhen, Guangdong, China  
**Product Name**..... : 4G Free Roaming Hotspot  
**Model No**..... : E1  
**Brand**..... : GlocalMe  
**Standards**..... : FCC CFR47 Part 22 Subpart H:2015  
FCC CFR47 Part 24 Subpart E:2015  
**Date of Receipt sample** .... : Feb. 17, 2016  
**Date of Test** ..... : Feb. 18 – Jun. 08, 2016  
**Date of Issue**..... : Jun. 08, 2016  
**Test Result**..... : **Pass**

Remarks:

The results shown in this test report refer only to the sample(s) tested, this test report cannot be reproduced, except in full, without prior written permission of the company. The report would be invalid without specific stamp of test institute and the signatures of compiler and approver.

**Prepared By:**

**Waltek Services (Shenzhen) Co., Ltd.**

Address: 1/F., Fukangtai Building, West Baima Road, Songgang Street, Baoan District, Shenzhen,  
Guangdong, China

Tel :+86-755-83551033

Fax:+86-755-83552400

Compiled by:



Zero Zhou / Test Engineer

Approved by:



Philo Zhong / Manager

## 2 Test Summary

Test Items	Test Requirement	Result
RF Output Power	2.1046 22.913 (a) 24.232 (c)	PASS
Peak-to-Average Ratio	24.232 (d)	PASS
Bandwidth	2.1049 22.905 22.917 24.238	PASS
Spurious Emissions at Antenna Terminal	2.1051 22.917 (a) 24.238 (a)	PASS
Field Strength of Spurious Radiation	2.1053 22.917 (a) 24.238 (a)	PASS
Out of band emission, Band Edge	22.917 (a) 24.238 (a)	PASS
Frequency Stability	2.1055 22.355 24.235	PASS
Maximum Permissible Exposure (SAR)	1.1307 2.1093	PASS

### 3 Contents

	<b>Page</b>
<b>1 COVER PAGE.....</b>	<b>1</b>
<b>2 TEST SUMMARY .....</b>	<b>2</b>
<b>3 CONTENTS .....</b>	<b>3</b>
<b>4 GENERAL INFORMATION.....</b>	<b>4</b>
4.1 GENERAL DESCRIPTION OF E.U.T. ....	4
4.2 DETAILS OF E.U.T. ....	4
4.3 TEST MODE .....	7
4.4 TEST FACILITY.....	7
<b>5 EQUIPMENT USED DURING TEST .....</b>	<b>8</b>
5.1 EQUIPMENTS LIST .....	8
5.2 MEASUREMENT UNCERTAINTY .....	9
5.3 TEST EQUIPMENT CALIBRATION .....	9
<b>6 RF OUTPUT POWER .....</b>	<b>10</b>
6.1 EUT OPERATION.....	10
6.2 TEST PROCEDURE .....	10
6.3 TEST RESULT .....	11
<b>7 PEAK-TO-AVERAGE RATIO.....</b>	<b>14</b>
7.1 EUT OPERATION.....	14
7.2 TEST PROCEDURE .....	14
7.3 TEST RESULT .....	15
<b>8 BANDWIDTH.....</b>	<b>17</b>
8.1 EUT OPERATION.....	17
8.2 TEST PROCEDURE .....	17
8.3 TEST RESULT .....	18
<b>9 SPURIOUS EMISSIONS AT ANTENNA TERMINALS .....</b>	<b>26</b>
9.1 EUT OPERATION.....	26
9.2 TEST PROCEDURE .....	26
9.3 TEST RESULT .....	27
<b>10 SPURIOUS RADIATED EMISSIONS.....</b>	<b>31</b>
10.1 EUT OPERATION .....	31
10.2 TEST SETUP .....	31
10.3 SPECTRUM ANALYZER SETUP .....	32
10.4 TEST PROCEDURE.....	33
10.5 SUMMARY OF TEST RESULTS .....	34
<b>11 BAND EDGE MEASUREMENT .....</b>	<b>36</b>
11.1 EUT OPERATION.....	36
11.2 TEST PROCEDURE.....	36
11.3 TEST RESULT .....	37
<b>12 FREQUENCY STABILITY.....</b>	<b>41</b>
12.1 EUT OPERATION.....	41
12.2 TEST PROCEDURE.....	41
12.3 TEST RESULT .....	42
<b>13 RF EXPOSURE.....</b>	<b>46</b>

## 4 General Information

### 4.1 General Description of E.U.T.

Product Name	: 4G Free Roaming Hotspot
Model No.	: E1
Model Description	: N/A
GSM Band(s)	: GSM 850/900/1800/1900MHz
GPRS/EDGE Class	: 12
CDMA	: 800/1900MHz
WCDMA Band(s)	: FDD Band I/II/IV/V/VIII
LTE Bnad(s)	: LTE Band 2/4/5/17/41
Wi-Fi Specification	: 2.4G: 802.11b/g/n HT20/n
Bluetooth Version	: Bluetooth v4.0 with BLE
GPS	: Support
NFC	: N/A
Hardware Version	LA0908 Ver.B
Software Version	E1_CTA_V01
storage location	: Internal Storage

Test Exercise : The EUT was operated in a normal mode.

Note: Main board(Modem1):  
 The EUT Main board support GSM850/900/DCS1800/PCS1900, CDMA 800/1900MHz,WCDMA Band 1/2/4/5/8, LTE Band 2/4/5/17/41 function. It is intended for speech, Multimedia Message Service (MMS) transmission and 4G free roaming hotspot. It is equipped with GPRS/EDGE class 12 for GSM850/900/DCS1800/PCS1900, GPS, Bluetooth and Wi-Fi functions. For more information see the following datasheet.  
 Vice board(Modem2):  
 The EUT Vice board support GSM850/900/DCS1800/PCS1900, CDMA 800/1900MHz, WCDMA Band 1/2/4/5/8. It is intended for system localization. It is equipped with GPRS/EDGE class 12 for GSM850/900/DCS1800/PCS1900

### 4.2 Details of E.U.T.

Operation Frequency	: GSM/GPRS/EDGE 850: 824~849MHz PCS/GPRS/EDGE 1900: 1850~1910MHz CDMA800 Ev-Do Rev. A: 824.70~848.31MHz CDMA1900 Ev-Do Rev. A: 1851.25~1908.75MHz WCDMA Band II: 1850~1910MHz WCDMA Band IV: 1710~1755MHz WCDMA Band V: 824~849MHz LTE Band 2: 1850~1910MHz LTE Band 4: 1710~1755MHz
---------------------	--

	<p>LTE Band 5: 824~849MHz          LTE Band 17: 706~714MHz          LTE Band 41: 2498~2688MHz          WiFi:          802.11b/g/n HT20: 2412~2462MHz          Bluetooth: 2402~2480MHz</p>
Max. RF output power	<p>: Main Board:          GSM 850: 32.62dBm          PCS1900:29.68dBm          CDMA800:24.64dBm          CDMA1900:24.47dBm          WCDMA Band II: 22.30dBm          WCDMA Band V: 22.25dBm          WCDMA Band IV: 22.59dBm          LTE Band 2: 23.49dBm          LTE Band 4: 23.5dBm          LTE Band 5: 23.63dBm          LTE Band 17: 23.79dBm          LTE Band 41: 23.85dBm          Vice Board:          GSM 850: 32.75dBm          PCS1900:29.75dBm          CDMA800:24.81dBm          CDMA1900:24.44dBm          WCDMA Band II: 22.46dBm          WCDMA Band V: 22.55dBm          WCDMA Band IV: 22.68dBm          WiFi(2.4G): 9.28dBm          Bluetooth: -0.37dBm</p>
Type of Modulation	<p>: GSM,GPRS: GMSK          CDMA2000 1xEV-DO:QPSK,8PSK          WCDMA: BPSK          LTE: QPSK, 16QAM          WiFi: CCK, OFDM          Bluetooth: GFSK, Pi/4 DQPSK,8DPSK</p>
Antenna installation	<p>: GSM/CDMA/WCDMA/LTE: internal permanent antenna          WiFi/Bluetooth: internal permanent antenna</p>
Antenna Gain	<p>Main Board:          GSM 850: -0.95dBi          PCS1900: -1.9dBi          CDMA800: -0.95dBi</p>

CDMA1900: -1.9dBi  
WCDMA Band II: -1.9dBi  
WCDMA Band IV: -2.6dBi  
WCDMA Band V: -0.95dBi  
LTE Band 2: -1.8dBi  
LTE Band 4: 0.05dBi  
LTE Band 5: -0.95dBi  
LTE Band 7: 0.9dBi  
LTE Band 17: -4.5dBi  
LTE Band 41: 1.5dBi  
Vice Board:  
GSM 850: -0.95dBi  
PCS1900: -1.9dBi  
CDMA800: -0.95dBi  
CDMA1900: -1.9dBi  
WCDMA Band II: -1.9dBi  
WCDMA Band IV: -2.6dBi  
WCDMA Band V: -0.95dBi  
WiFi(2.4G): 0dBi  
Bluetooth: 0dBi

Technical Data:

Battery DC 3.8V, 13.3Wh  
DC 5V, 1.0A, charging from mini USB port

### 4.3 Test Mode

All test mode(s) and condition(s) mentioned were considered and evaluated respectively by performing full tests, the worst data were recorded and reported.

Support Band	Test Mode	Channel Frequency	Channel Number
CDMA 800	Ev-Do Rev.A	824.70 MHz	1013
		836.52 MHz	384
		848.31 MHz	777
CDMA 1900	Ev-Do Rev.A	1851.25 MHz	25
		1880.00 MHz	600
		1908.75 MHz	1175
Remark: This device only supports data communication without Voice.			

### 4.4 Test Facility

The test facility has a test site registered with the following organizations:

- IC – Registration No.: 7760A**  
 Waltek Services(Shenzhen) Co., Ltd. Has been registered and fully described in a report filed with the Industry Canada. The acceptance letter from the Industry Canada is maintained in our files. Registration number 7760A, October 15, 2015.
- FCC Test Site 1#– Registration No.: 880581**  
 Waltek Services(Shenzhen) Co., Ltd. EMC Laboratory `has been registered and fully described in a report filed with the (FCC) Federal Communications Commission. The acceptance letter from the FCC is maintained in our files. Registration 880581, April 29, 2014.
- FCC Test Site 2#– Registration No.: 328995**  
 Waltek Services(Shenzhen) Co., Ltd. EMC Laboratory `has been registered and fully described in a report filed with the (FCC) Federal Communications Commission. The acceptance letter from the FCC is maintained in our files. Registration 328995, December 3, 2014.

## 5 Equipment Used during Test

### 5.1 Equipments List

<b>RF Conducted Test</b>						
<b>Item</b>	<b>Equipment</b>	<b>Manufacturer</b>	<b>Model No.</b>	<b>Serial No.</b>	<b>Last Calibration Date</b>	<b>Calibration Due Date</b>
1.	EMC Analyzer (9k~26.5GHz)	Agilent	E7405A	MY45114943	Aug.15,2015	Aug.14,2016
2.	Spectrum Analyzer (9k-6GHz)	R&S	FSL6	100959	Aug.15,2015	Aug.14,2016
3.	Humidity Chamber	GF	GTH-225-40-1P	IAA061213	Aug.15,2015	Aug.14,2016
4.	Universal Radio Communication Tester	R&S	CMU 200	112461	Aug.15,2015	Aug.14,2016
<b>3m Semi-anechoic Chamber for Radiated Emissions</b>						
<b>Item</b>	<b>Equipment</b>	<b>Manufacturer</b>	<b>Model No.</b>	<b>Serial No.</b>	<b>Last Calibration Date</b>	<b>Calibration Due Date</b>
1	EMC Analyzer	Agilent	E7405A	MY45114943	Sep.15,2015	Sep.14,2016
2	Active Loop Antenna	Beijing Dazhi	ZN30900A	-	Sep.15,2015	Sep.14,2016
3	Trilog Broadband Antenna	SCHWARZBECK	VULB9163	336	Aug.15,2015	Aug.14,2016
4	Coaxial Cable (below 1GHz)	Top	TYPE16(13M)	-	Sep.15,2015	Sep.14,2016
5	Broad-band Horn Antenna	SCHWARZBECK	BBHA 9120 D	667	Apr.18,2015	Apr.17,2016
6	Broad-band Horn Antenna	SCHWARZBECK	BBHA 9120 D	669	Apr.18,2015	Apr.17,2016
7	Broadband Preamplifier	COMPLIANCE DIRECTION	PAP-1G18	2004	Sep.15,2015	Sep.14,2016
8	Coaxial Cable (above 1GHz)	Top	1000MHZ- 25GHz	EW02014-7	Aug.15,2015	Aug.14,2016
9	Broad-band Horn Antenna	SCHWARZBECK	BBHA 9170	335	Sep.15,2015	Sep.14,2016
10	Universal Radio Communication Tester	R&S	CMU 200	112461	Aug.15,2015	Aug.14,2016
11	Signal Generator	R&S	SMR20	100046	Sep.15,2015	Sep.14,2016



## 5.2 Measurement Uncertainty

Parameter	Uncertainty
Radio Frequency	$\pm 1 \times 10^{-6}$
RF Power	$\pm 1.0$ dB
RF Power Density	$\pm 2.2$ dB
Radiated Spurious Emissions test	$\pm 5.03$ dB (Bilog antenna 30M~1000MHz)
	$\pm 5.47$ dB (Horn antenna 1000M~25000MHz)
Conducted Spurious Emissions test	$\pm 3.64$ dB (AC mains 150KHz~30MHz)

## 5.3 Test Equipment Calibration

All the test equipments used are valid and calibrated by CEPREI Certification Body that address is No.110 Dongguan Zhuang RD. Guangzhou, P.R.China.

## 6 RF OUTPUT POWER

Test Requirement:	FCC Part 2.1046, 22.913 (a),24.232 (c)
Test Method:	TIA/EIA-603-D:2010 KDB971168 D01 v02r02
Test Mode:	Transmitting

### 6.1 EUT Operation

Operating Environment :

Temperature:	22.5 °C
Humidity:	52.1 % RH
Atmospheric Pressure:	101.2kPa

### 6.2 Test Procedure

Conducted method:

The RF output of the transmitter was connected to the wireless test set and the spectrum analyzer through sufficient attenuation.

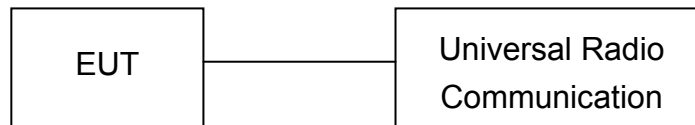

Radiated method:

1. The setup of EUT is according with per TIA/EIA Standard 603D measurement procedure.
2. The measurement antenna was placed at a distance of 3 meters from the EUT. During the tests, the antenna height and polarization as well as EUT azimuth were varied in order to identify the maximum level of emissions from the EUT. The test was performed by placing the EUT on 3-orthogonal axis.
3. The frequency range up to tenth harmonic of the fundamental frequency was investigated.
4. Remove the EUT and replace it with substitution antenna. A signal generator was connected to the substitution antenna by a non-radiating cable. The absolute levels of the spurious emissions were measured by the substitution.

### 6.3 Test Result

#### Main board

Conducted Power(dBm)						
Band	CDMA2000 BC0			CDMA2000 BC1		
Channel	1013	384	777	25	600	1175
Frequency	824.70	836.52	848.31	1851.25	1880.00	1908.75
Ev-Do Rev.A RTAP 153.6kpbs	<b>24.64</b>	24.14	24.30	24.34	23.78	<b>24.47</b>
Ev-Do Rev.A RETAP 4096Bits	24.52	24.08	24.16	24.21	23.65	24.33

#### Vice board

Conducted Power(dBm)						
Band	CDMA2000 BC0			CDMA2000 BC1		
Channel	1013	384	777	25	600	1175
Frequency	824.70	836.52	848.31	1851.25	1880.00	1908.75
Ev-Do Rev.A RTAP 153.6kpbs	<b>24.81</b>	24.45	24.23	24.19	<b>24.44</b>	24.05
Ev-Do Rev.A RETAP 4096Bits	24.65	24.31	24.19	24.30	24.18	24.31

**Radiated Power(Measured at max. conducted power channel)**

Main board

Max. ERP and EIRP

Cellular Band (Part 22H)

Frequency	Receiver Reading	Turn table Angle	RX Antenna		Substituted			Absolute Level	Part 22H	
			Height	Polar	SG Level	Cable	Antenna Gain		Limit	Margin
(MHz)	(dBμV)	Degree	(m)	(H/V)	(dBm)	(dB)	(dB)	(dBm)	(dBm)	(dB)
CDMA 800 Channel 1013										
824.70	90.36	150	1.9	H	23.33	0.20	0.00	23.13	38.45	-15.32
824.70	97.16	249	2.5	V	30.06	0.20	0.00	24.31	38.45	-14.14
CDMA 800 Channel 384										
836.52	91.35	223	1.3	H	24.32	0.20	0.00	24.12	38.45	-14.33
836.52	97.90	79	1.1	V	30.80	0.20	0.00	26.13	38.45	-12.32
CDMA 800 Channel 777										
848.31	92.78	245	1.4	H	25.75	0.20	0.00	25.55	38.45	-12.90
848.31	97.44	154	1.5	V	30.34	0.20	0.00	24.65	38.45	-13.80

Cellular Band (Part 24E)

Frequency	Receiver Reading	Turn table Angle	RX Antenna		Substituted			Absolute Level	Part 24E	
			Height	Polar	SG Level	Cable	Antenna Gain		Limit	Margin
(MHz)	(dBμV)	Degree	(m)	(H/V)	(dBm)	(dB)	(dB)	(dBm)	(dBm)	(dB)
CDMA 1900 Channel 25										
1851.25	86.53	315	2.3	H	12.56	0.31	10.40	22.65	33	-10.35
1851.25	92.00	123	2.3	V	18.72	0.31	10.40	28.81	33	-4.19
CDMA 1900 Channel 600										
1880.00	84.70	92	1.6	H	10.85	0.31	10.40	20.94	33	-12.06
1880.00	92.77	178	1.7	V	19.65	0.31	10.40	29.74	33	-3.26
CDMA 1900 Channel 1175										
1908.75	85.02	357	1.9	H	11.29	0.32	10.40	21.37	33	-11.63
1908.75	92.89	270	1.7	V	19.93	0.32	10.40	30.01	33	-2.99

Vice board  
ERP and EIRP  
Cellular Band (Part 22H)

Frequency	Receiver Reading	Turn table Angle	RX Antenna		Substituted			Absolute Level	Part 22H	
			Height	Polar	SG Level	Cable	Antenna Gain		Limit	Margin
(MHz)	(dB $\mu$ V)	Degree	(m)	(H/V)	(dBm)	(dB)	(dB)	(dBm)	(dBm)	(dB)
CDMA 800 Channel 1013										
824.70	92.12	224	1.2	H	25.09	0.20	0.00	24.36	38.45	-14.09
824.70	97.36	340	1.0	V	30.26	0.20	0.00	26.18	38.45	-12.27
CDMA 800 Channel 384										
836.52	90.54	83	1.9	H	23.51	0.20	0.00	23.31	38.45	-15.14
836.52	97.47	9	2.4	V	30.37	0.20	0.00	24.59	38.45	-13.86
CDMA 800 Channel 777										
848.31	90.20	65	1.1	H	23.17	0.20	0.00	22.97	38.45	-15.48
848.31	97.23	89	2.2	V	30.13	0.20	0.00	24.65	38.45	-13.80

Cellular Band (Part 24E)

Frequency	Receiver Reading	Turn table Angle	RX Antenna		Substituted			Absolute Level	Part 24E	
			Height	Polar	SG Level	Cable	Antenna Gain		Limit	Margin
(MHz)	(dB $\mu$ V)	Degree	(m)	(H/V)	(dBm)	(dB)	(dB)	(dBm)	(dBm)	(dB)
CDMA 1900 Channel 25										
1851.25	86.86	96	1.6	H	12.89	0.31	10.40	26.35	33	-6.65
1851.25	92.69	328	2.2	V	19.41	0.31	10.40	23.21	33	-9.79
CDMA 1900 Channel 600										
1880.00	87.25	133	1.8	H	13.40	0.31	10.40	25.32	33	-7.68
1880.00	92.78	205	1.8	V	19.66	0.31	10.40	22.95	33	-10.05
CDMA 1900 Channel 1175										
1908.75	84.68	16	1.2	H	10.95	0.32	10.40	21.03	33	-11.97
1908.75	92.47	37	1.1	V	19.51	0.32	10.40	26.12	33	-6.88

## 7 Peak-to-Average Ratio

Test Requirement:	24.232 (d)
Test Method:	N/A
Test Mode:	Transmitting

### 7.1 EUT Operation

Operating Environment :

Temperature:	22.5 °C
Humidity:	52.3% RH
Atmospheric Pressure:	101.2kPa

### 7.2 Test Procedure

1. The EUT was connected to spectrum analyzer and system simulator via a power divider.
2. Set EUT to transmit at maximum output power.
3. When the duty cycle is less than 98%, then signal gating will be implemented on the spectrum analyzer by triggering from the system simulator.
4. Set the CCDF (Complementary Cumulative Distribution Function) option of the spectrum analyzer. Record the maximum PAPR level associated with a probability of 0.1%.

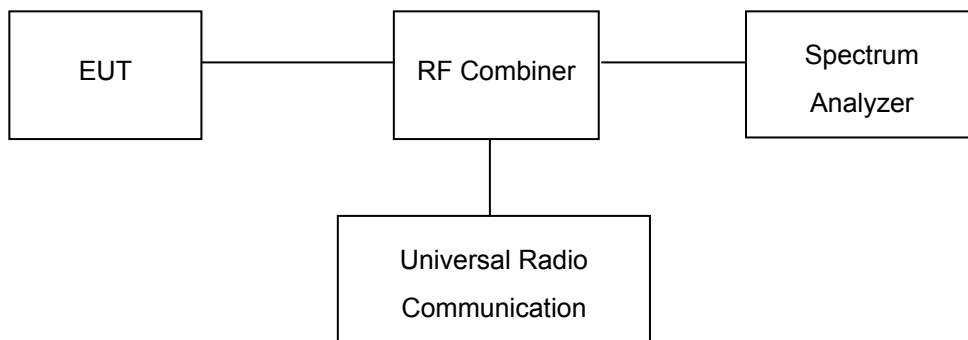

### 7.3 Test Result

#### Cellular Band (Part 24E)

##### Main board

Mode	CDMA 1900			Limit (dB)
Channel	25	600	1175	
Frequency (MHz)	1851.25	1880.00	1908.75	
Peak-to-Average Ratio (dB)	4.26	4.28	4.35	13

#### Test Plots (Part 24E)

##### CDMA 1900 Middle Channel

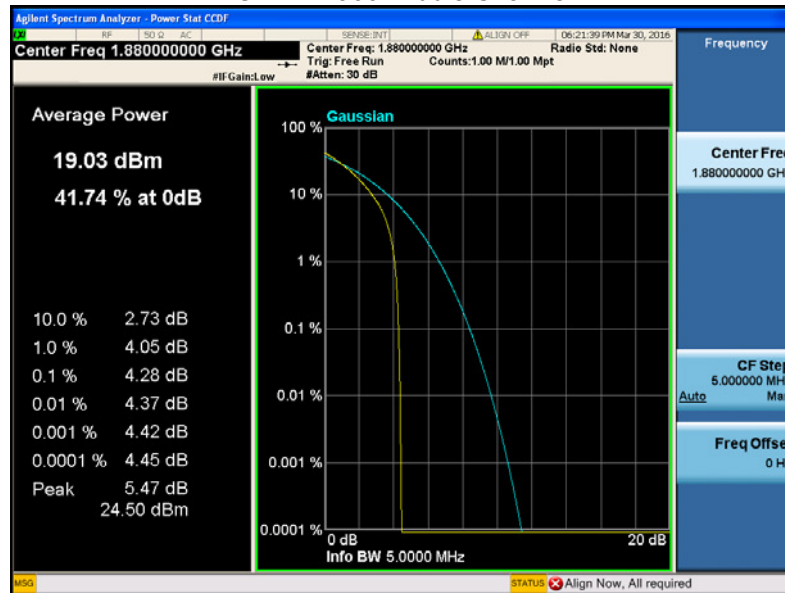

Voice board

Mode	CDMA 1900			Limit (dB)
Channel	25	600	1175	
Frequency (MHz)	1851.25	1880.00	1908.75	
Peak-to-Average Ratio (dB)	4.26	4.31	4.37	13

Test Plots (Part 24E)

CDMA 1900 Middle Channel

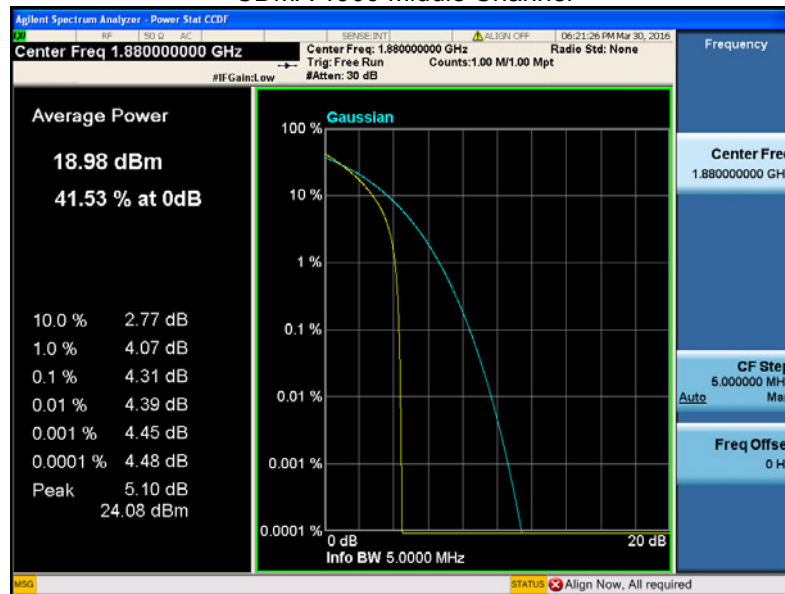



## 8 BANDWIDTH

Test Requirement:	FCC Part 2.1049,22.917,22.905,24.238
Test Method:	TIA/EIA-603-D:2010 KDB971168 D01 v02r02
Test Mode:	Transmitting

### 8.1 EUT Operation

Operating Environment :

Temperature:	22.5 °C
Humidity:	52.3% RH
Atmospheric Pressure:	101.2kPa

### 8.2 Test Procedure

The RF output of the transmitter was connected to the wireless test set and the spectrum analyzer through sufficient attenuation.

The resolution bandwidth of the spectrum analyzer was set at 3 kHz (Cellular /PCS) and the 26 dB & 99%bandwidth was recorded.

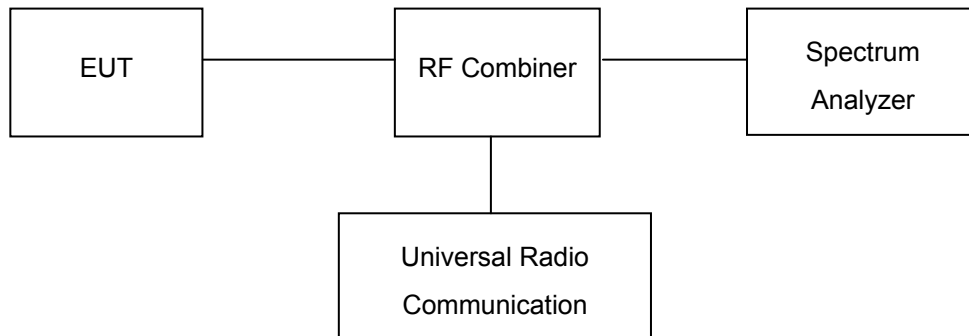

### 8.3 Test Result

#### Main board

Test Mode	Channel	Frequency (MHz)	99% Occupied Bandwidth(mHz)	26 dB Emission Bandwidth(mHz)
CDMA 800	1013	824.70	1.27	1.42
	384	836.52	1.27	1.42
	777	848.31	1.28	1.45
CDMA 1900	25	1851.25	1.28	1.44
	600	1880.00	1.28	1.43
	1175	1908.75	1.30	1.77

#### Test Plots

#### CDMA 800 Low Channel

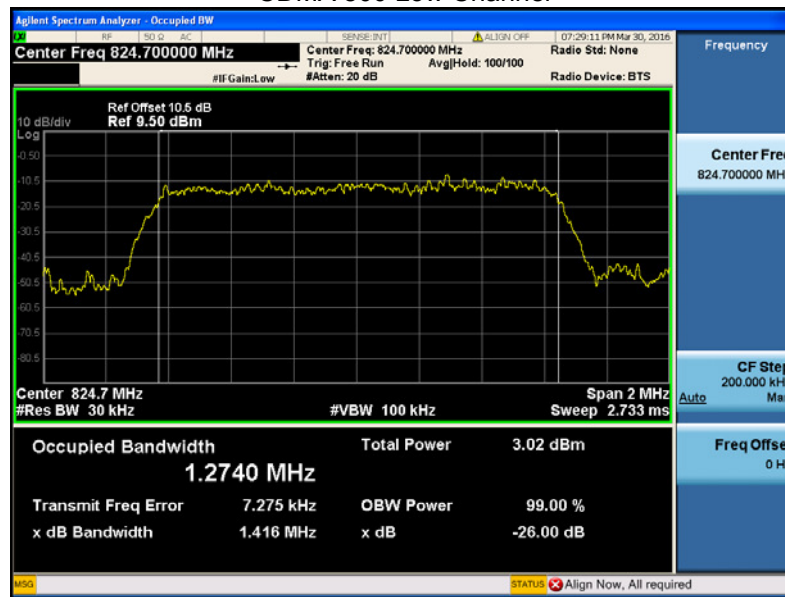

CDMA 800 Middle Channel

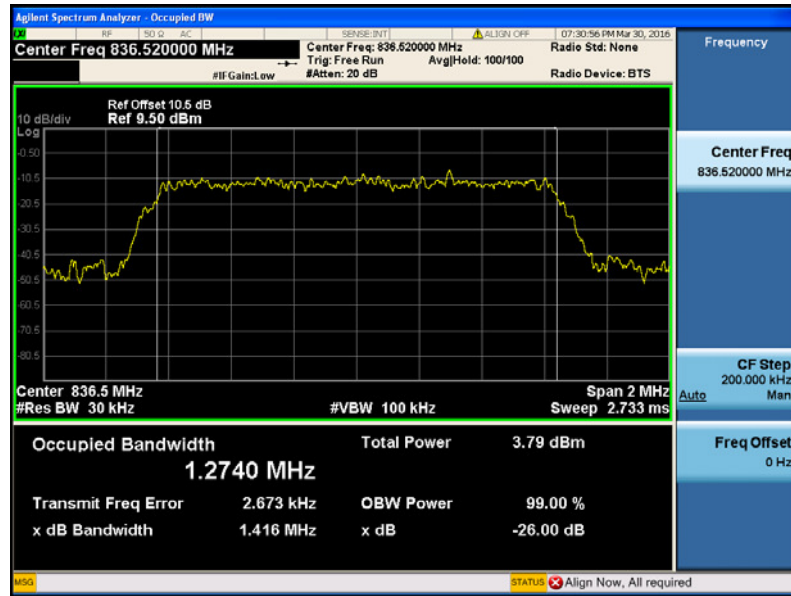

CDMA 800 High Channel

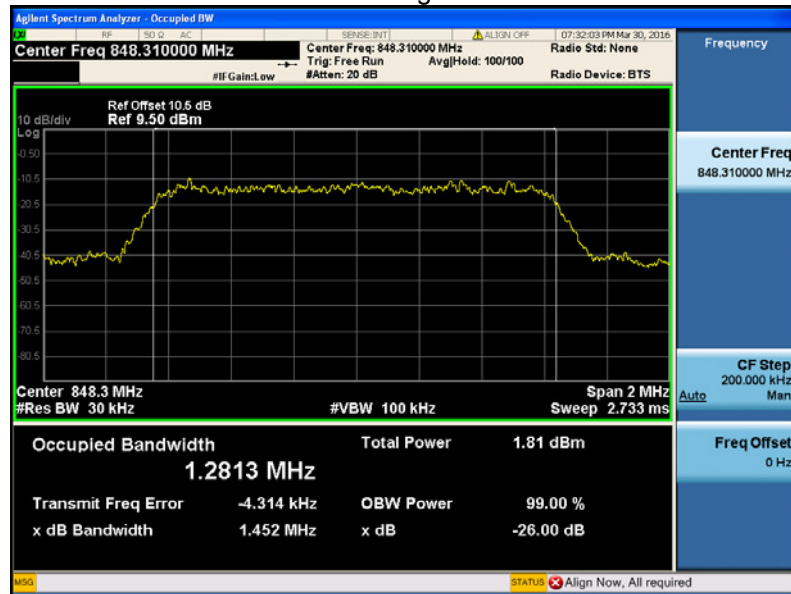

CDMA 1900 Low Channel

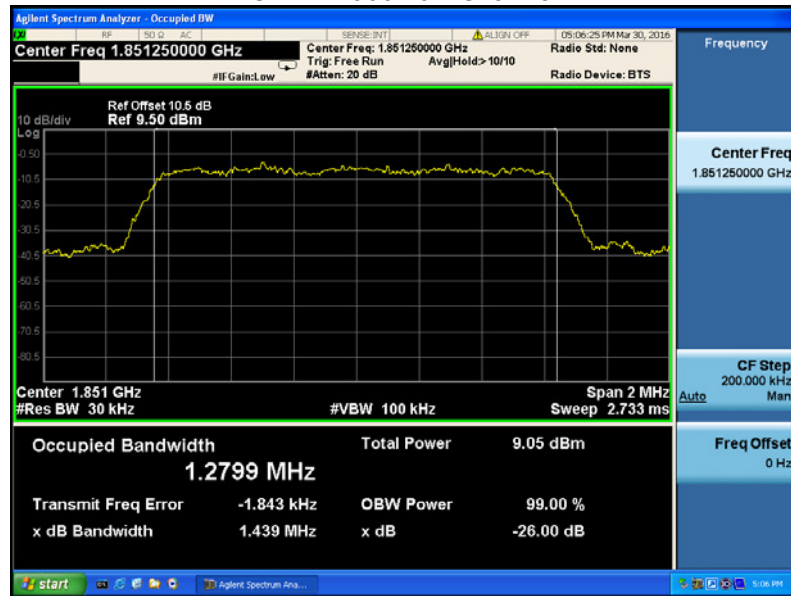

CDMA 1900 Middle Channel

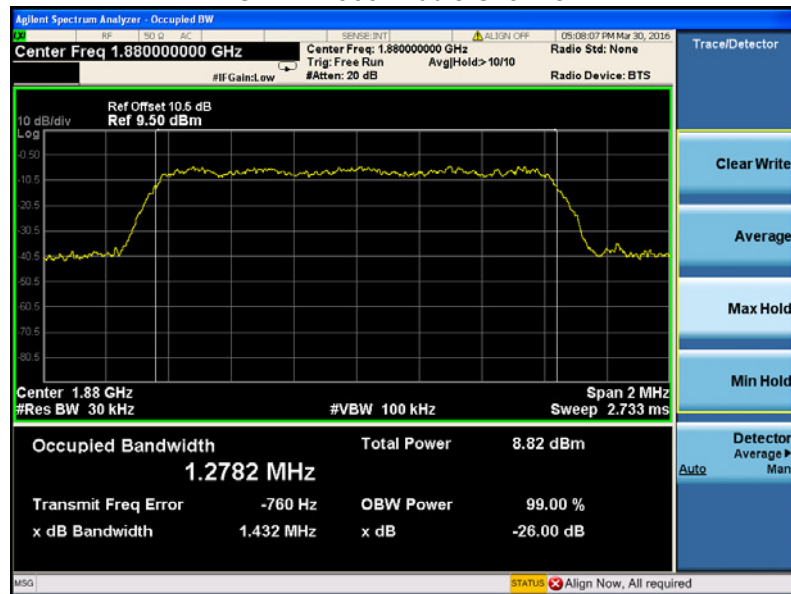

CDMA 1900 High Channel

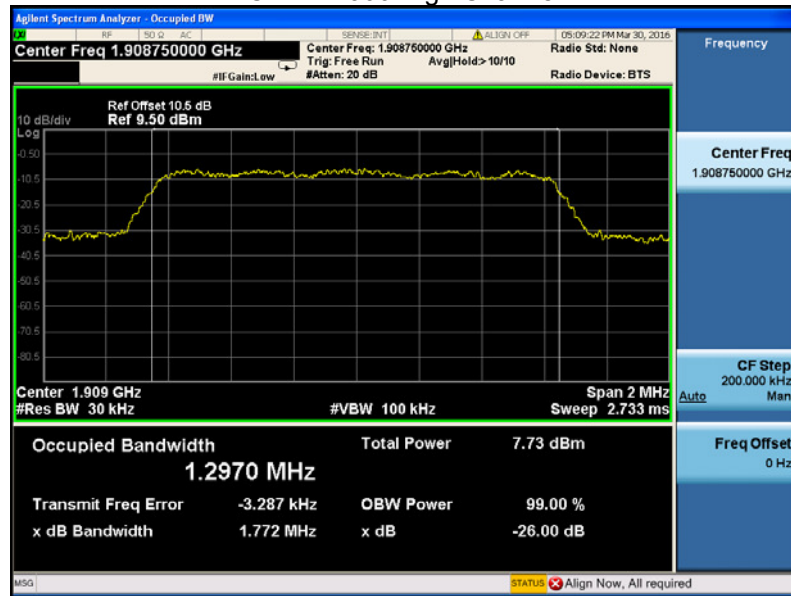

Vice board

Test Mode	Channel	Frequency (MHz)	99% Occupied Bandwidth(kHz)	26 dB Emission Bandwidth(kHz)
CDMA 800	1013	824.70	1.27	1.42
	384	836.52	1.27	1.43
	777	848.31	1.29	1.44
CDMA 1900	25	1851.25	1.28	1.44
	600	1880.00	1.28	1.45
	1175	1908.75	1.31	1.86

Test Plots

CDMA 800 Low Channel

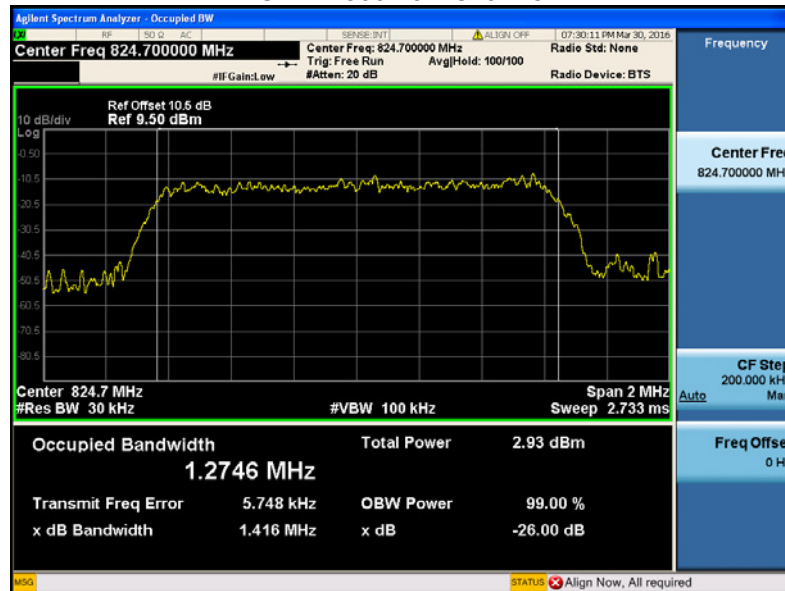

CDMA 800 Middle Channel

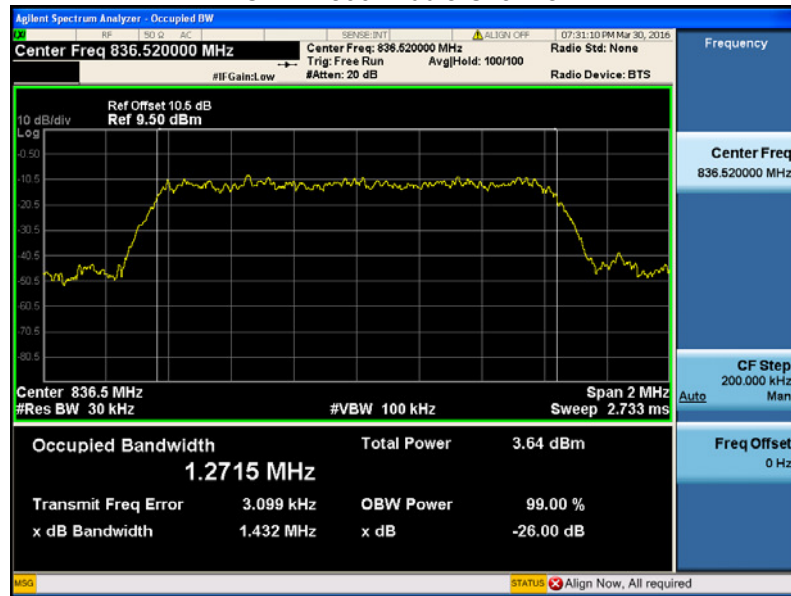

CDMA 800 High Channel

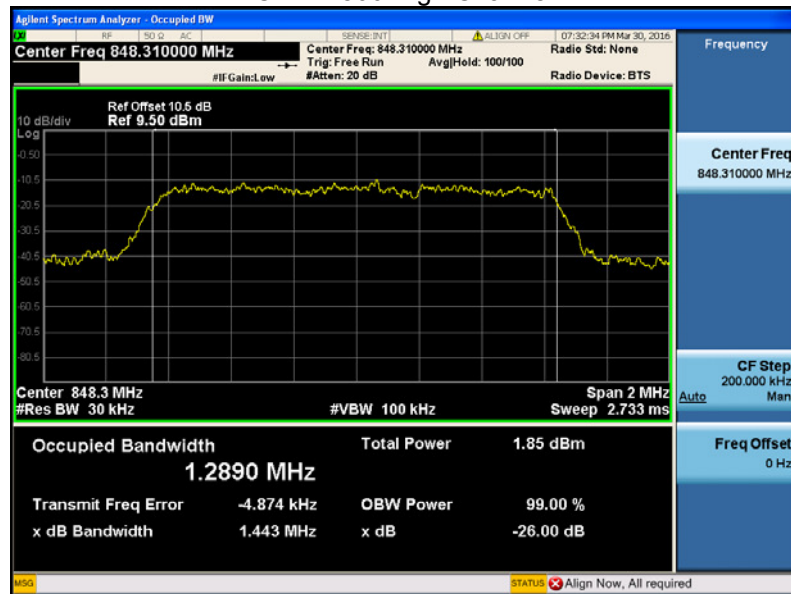

CDMA 1900 Low Channel

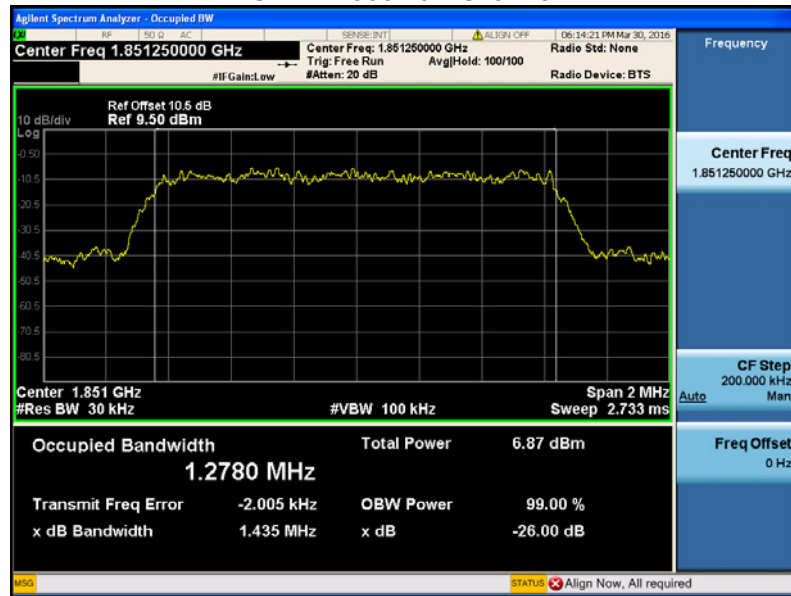

CDMA 1900 Middle Channel

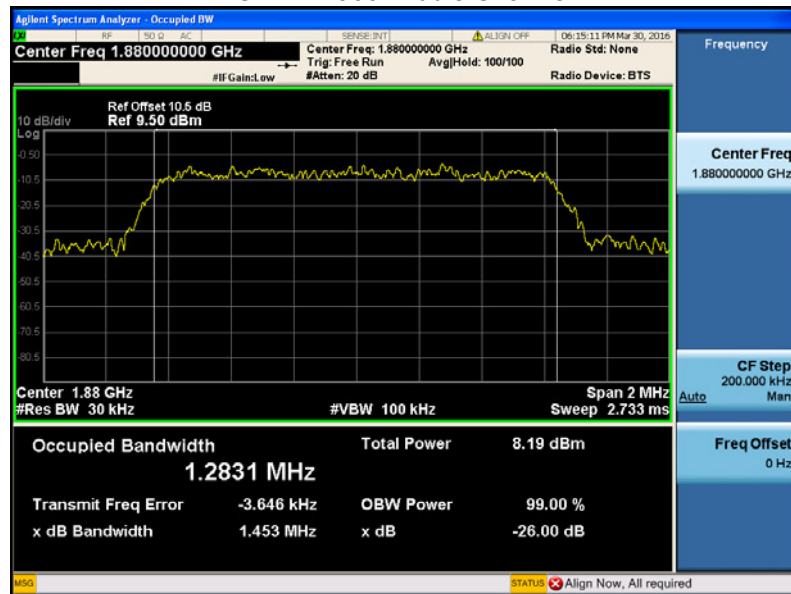



CDMA 1900 High Channel

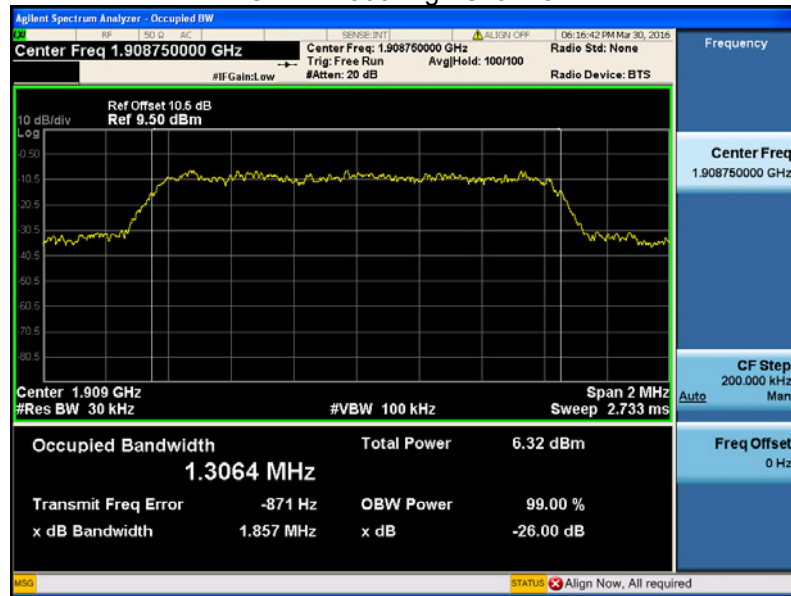

## 9 SPURIOUS EMISSIONS AT ANTENNA TERMINALS

Test Requirement:	FCC Part 2.1051,22.917(a),24.238(a)
Test Method:	TIA/EIA-603-D:2010 KDB971168 D01 v02r02
Test Mode:	Transmitting

### 9.1 EUT Operation

Operating Environment :

Temperature:	23.5 °C
Humidity:	52.1 % RH
Atmospheric Pressure:	101.3kPa

### 9.2 Test Procedure

The RF output of the transceiver was connected to a spectrum analyzer and simulator through appropriate attenuation. The resolution bandwidth of the spectrum analyzer was set at 1MHz. Sufficient scans were taken to show any out of band emissions up to 10th harmonics.

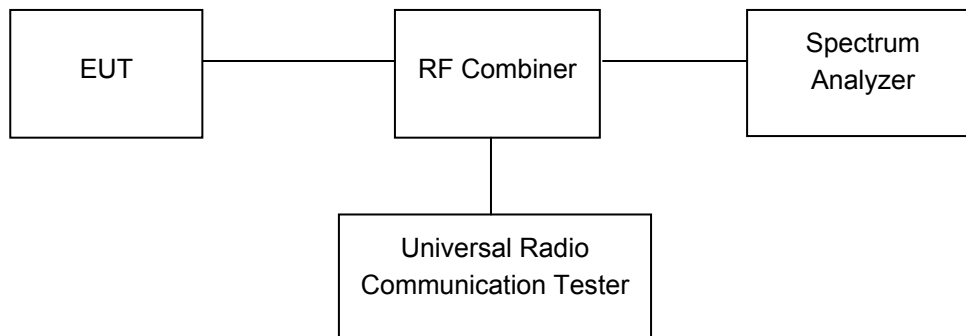

### 9.3 Test Result

Remark: only the worst data were recorded.

Cellular Band (Part 22H)

Main board

CDMA 800 - channel 384

30MHz-1GHz

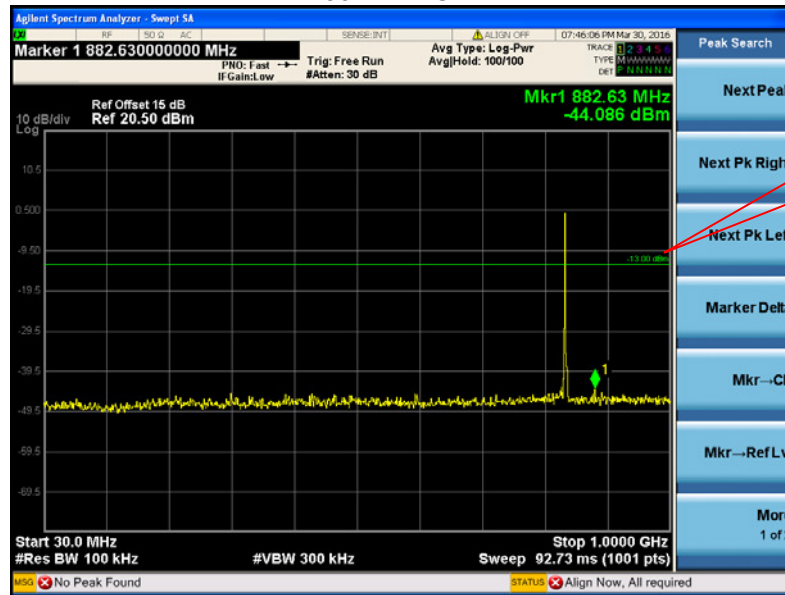

Fundamental

Above 1GHz

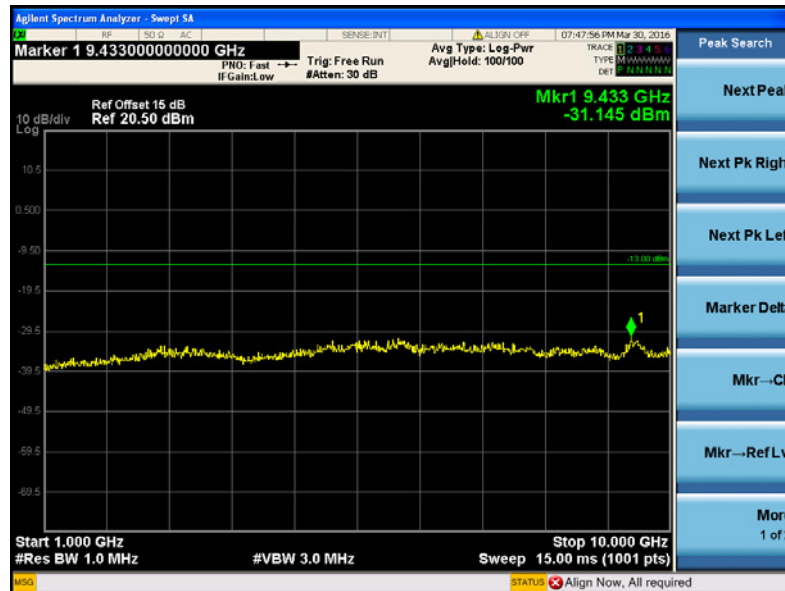

Cellular Band (Part 24E)  
CDMA 1900 - channel 600  
30MHz-1GHz

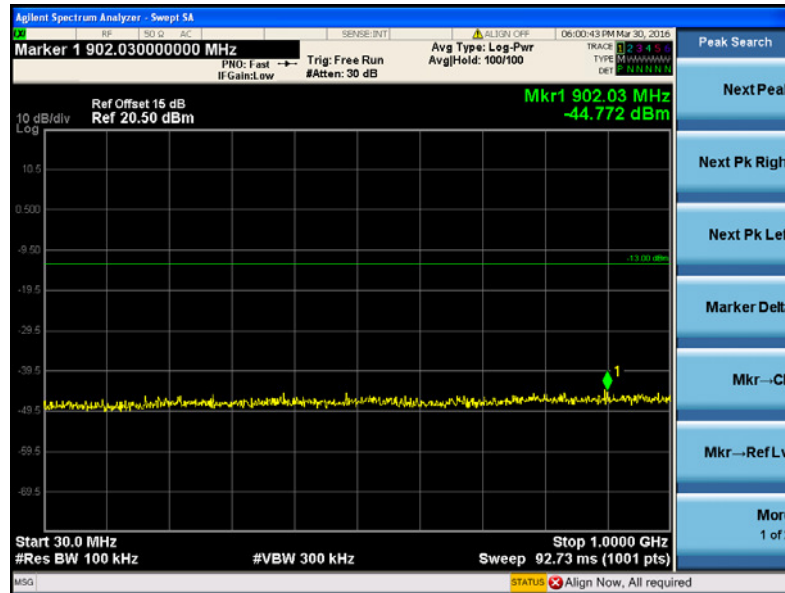

Above 1GHz

Fundamental

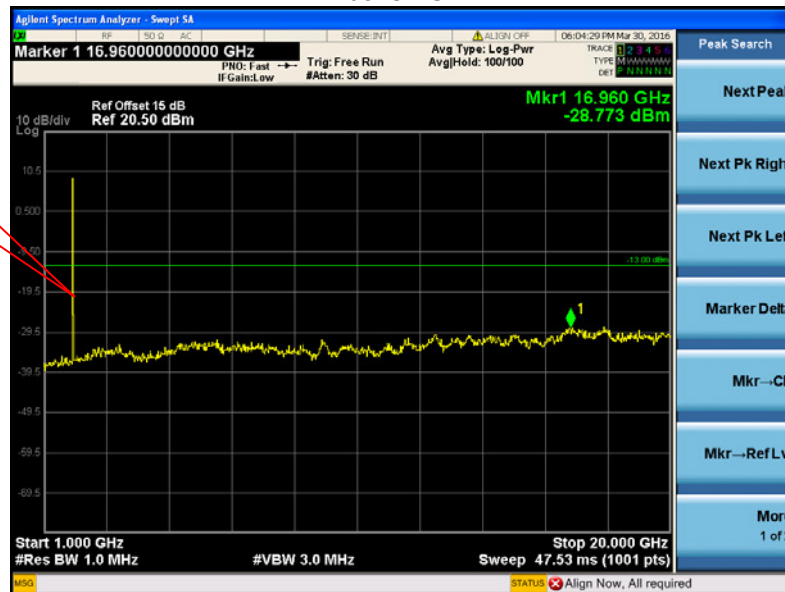

Vice board  
CDMA 800 - channel 384  
30MHz-1GHz

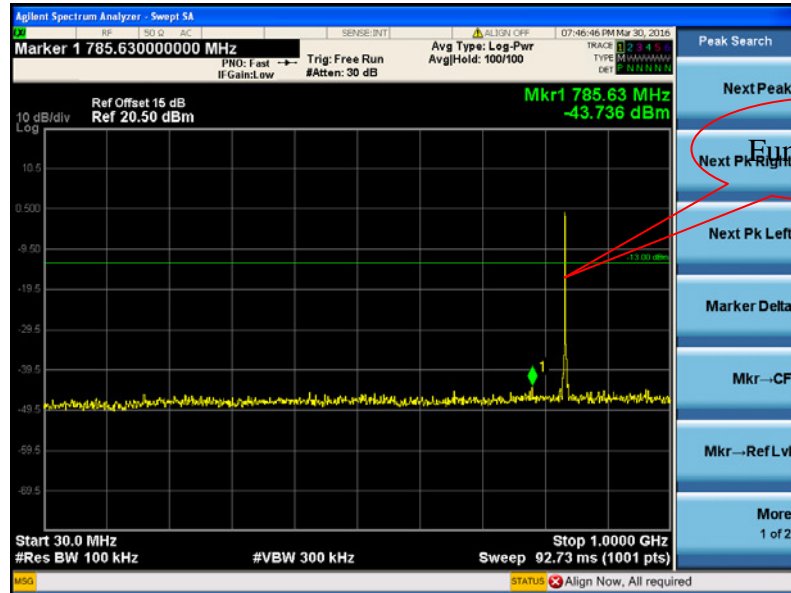

Above 1GHz

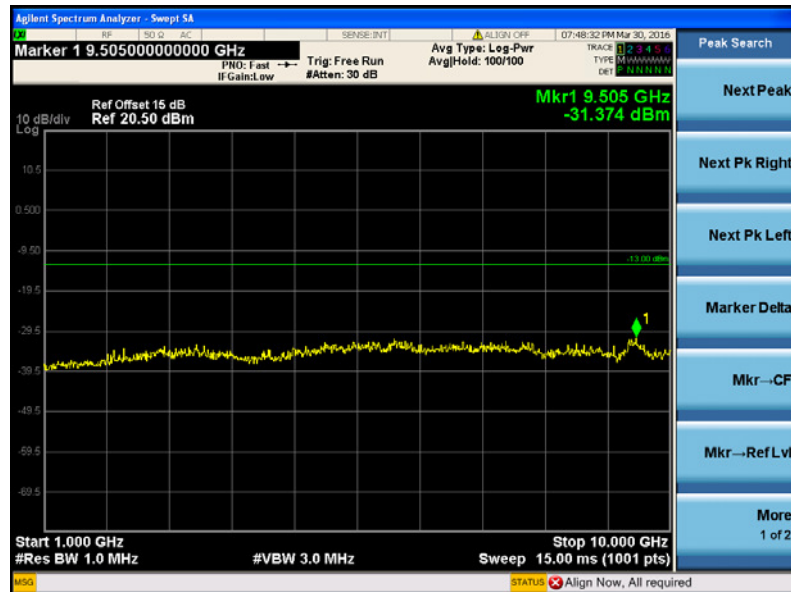

Cellular Band (Part 24E)  
CDMA 1900 - channel 600  
30MHz-1GHz

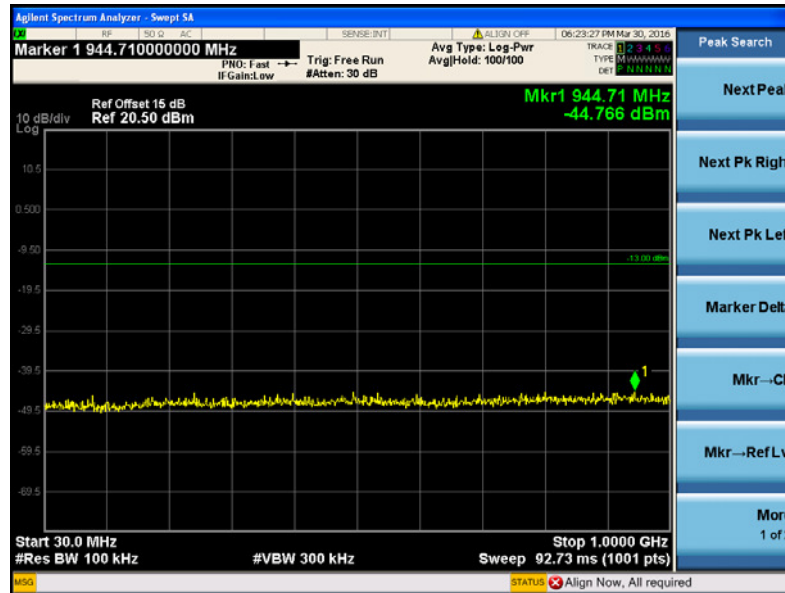

Above 1GHz

Fundamental

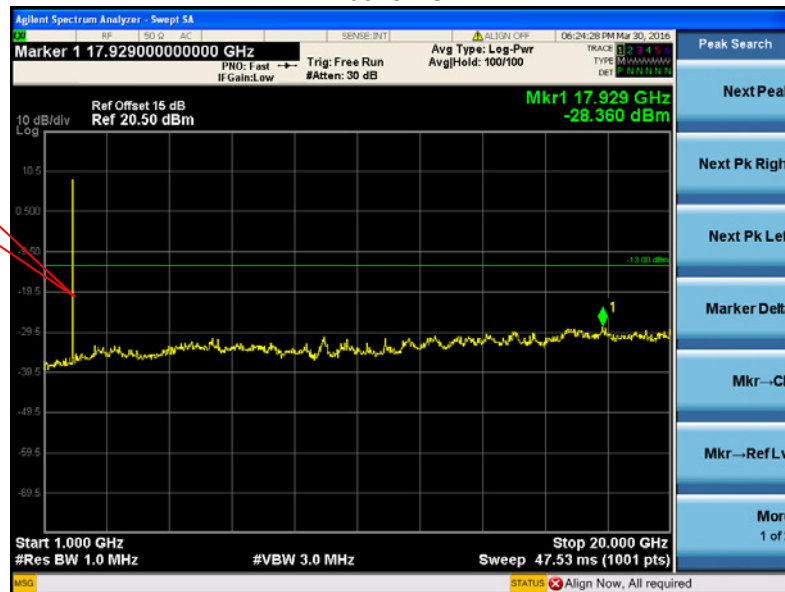

## 10 SPURIOUS RADIATED EMISSIONS

Test Requirement: FCC Part 2.1053,22.917,24.238,27.53(h)

Test Method: TIA/EIA-603-D:2010  
KDB971168 D01 v02r02

Test Mode: Transmitting

### 10.1 EUT Operation

Operating Environment :

Temperature: 23.5 °C

Humidity: 52.1 % RH

Atmospheric Pressure: 101.2kPa

### 10.2 Test Setup

The radiated emission tests were performed in the 3m Semi- Anechoic Chamber test site, using the setup accordance with the test setup for emission measurement from 30 MHz to 1 GHz.

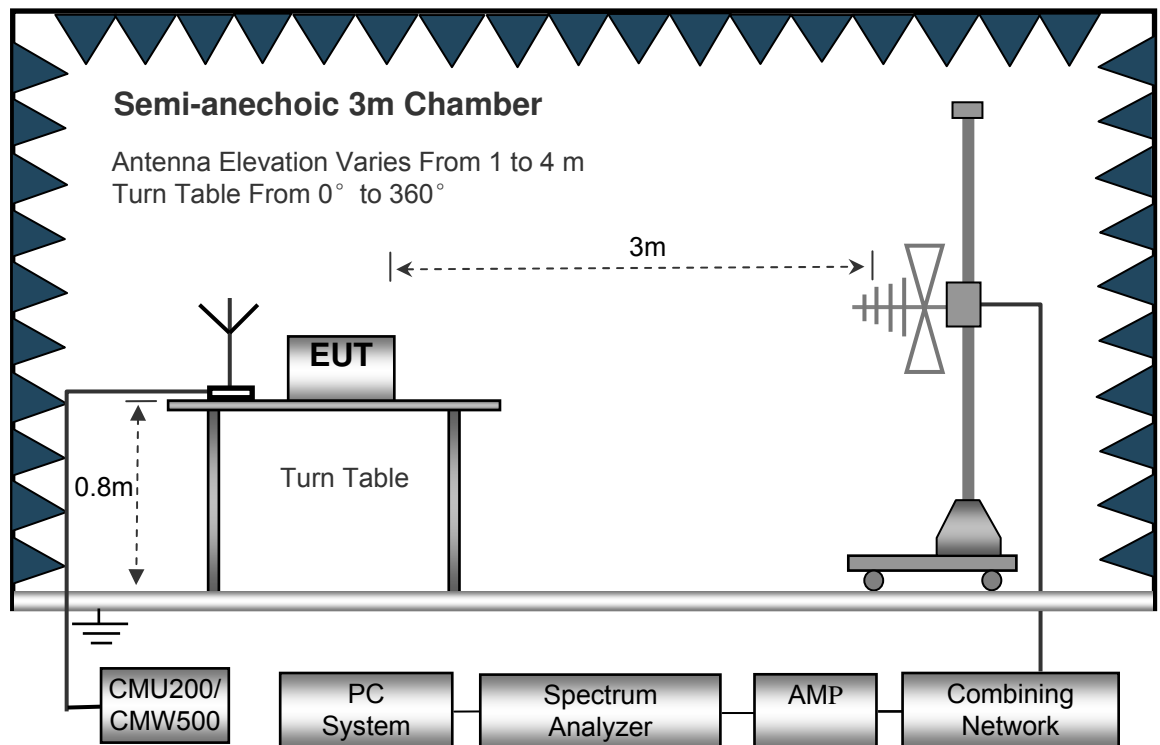

The test setup for emission measurement above 1 GHz.

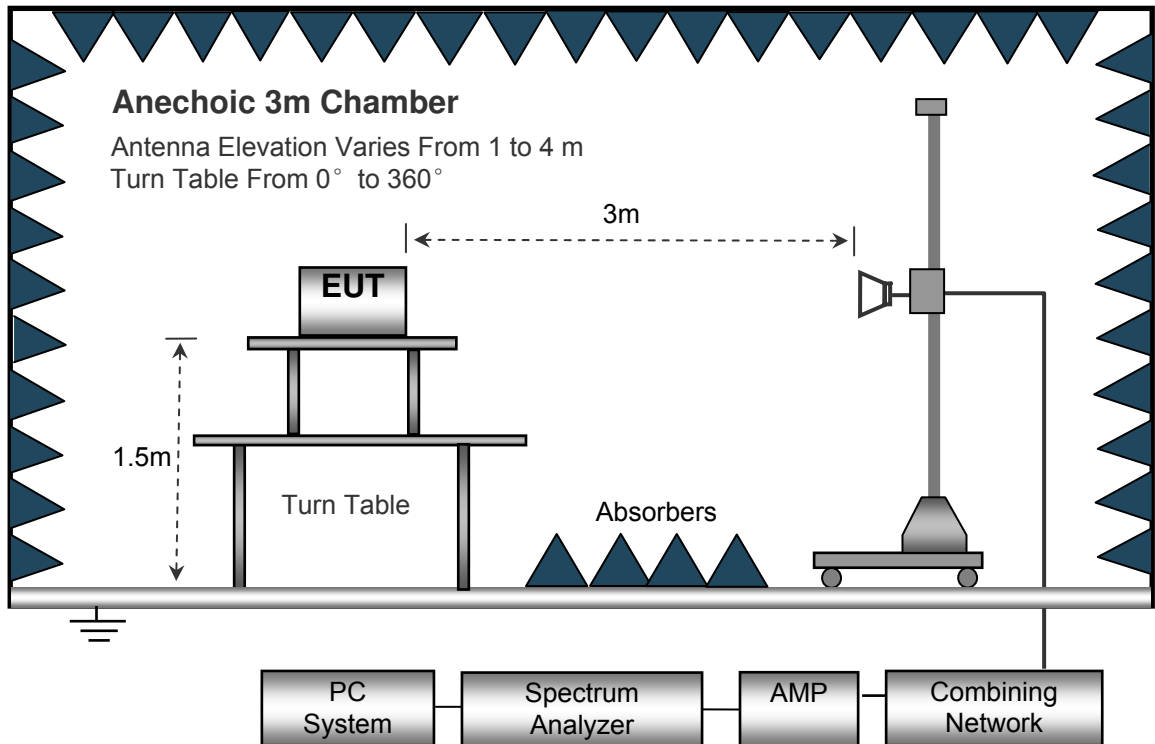

### 10.3 Spectrum Analyzer Setup

30MHz ~ 1GHz

Sweep Speed ..... Auto  
 Detector ..... PK  
 Resolution Bandwidth..... 100kHz  
 Video Bandwidth..... 300kHz

Above 1GHz

Sweep Speed ..... Auto  
 Detector ..... PK  
 Resolution Bandwidth..... 1MHz  
 Video Bandwidth..... 3MHz  
 Detector ..... Ave.  
 Resolution Bandwidth..... 1MHz  
 Video Bandwidth..... 10Hz



## 10.4 Test Procedure

1. The EUT is placed on a turntable, which is 1.5m above ground plane.
2. The turntable shall be rotated for 360 degrees to determine the position of maximum emission level.
3. EUT is set 3m away from the receiving antenna, which is moved from 1m to 4m to find out the maximum emissions. The spectrum was investigated from 30MHz up to the tenth harmonic of the highest fundamental frequency.
4. Maximum procedure was performed on the six highest emissions to ensure EUT compliance.
5. And also, each emission was to be maximized by changing the polarization of receiving antenna both horizontal and vertical.
6. The radiation measurements are tested under 3-axes(X,Y,Z) position(X denotes lying on the table, Y denotes side stand and Z denotes vertical stand), After pre-test, It was found that the worse radiation emission was get at the X position. So the data shown was the X position only.
7. Remove the EUT and replace it with substitution antenna. A signal generator was connected to the substitution antenna by a non-radiating cable. The absolute levels of the spurious emissions were measured by the substitution.  
Spurious emissions in dB =  $10 \lg(\text{TXpwr in Watts}/0.001)$  – the absolute level  
Spurious attenuation limit in dB =  $43 + 10 \text{Log}_{10}(\text{power out in Watts})$
8. Repeat above procedures until the measurements for all frequencies are completed.

## 10.5 Summary of Test Results

For 19.2MHz,

The measurements were more than 20 dB below the limit and not reported.

Remark: Test performed from 30MHz to 10<sup>th</sup> harmonics with low/middle/high channels, only the worst data were recorded.

Main board

### Cellular Band (Part 22H)

Frequency	Receiver Reading	Turn table Angle	RX Antenna		Substituted			Absolute Level	Result	
			Height	Polar	SG Level	Cable	Antenna Gain		Limit	Margin
(MHz)	(dB $\mu$ V)	Degree	(m)	(H/V)	(dBm)	(dB)	(dB)	(dBm)	(dBm)	(dB)
CDMA 800 Channel 1013										
201.33	41.43	262	1.4	H	-69.08	0.15	0.00	-69.23	-13.00	-56.23
201.33	45.65	318	1.2	V	-61.94	0.15	0.00	-62.09	-13.00	-49.09
1649.40	65.47	293	1.8	H	-48.50	0.30	9.40	-39.40	-13.00	-26.40
1649.40	58.32	298	1.9	V	-55.21	0.30	9.40	-46.11	-13.00	-33.11
2474.10	55.36	337	1.2	H	-58.64	0.43	10.60	-48.47	-13.00	-35.47
2474.10	49.35	110	2.0	V	-60.93	0.43	10.60	-50.76	-13.00	-37.76

### Cellular Band (Part 24E/27)

Frequency	Receiver Reading	Turn table Angle	RX Antenna		Substituted			Absolute Level	Result	
			Height	Polar	SG Level	Cable	Antenna Gain		Limit	Margin
(MHz)	(dB $\mu$ V)	Degree	(m)	(H/V)	(dBm)	(dB)	(dB)	(dBm)	(dBm)	(dB)
CDMA 1900 Channel 1175										
201.33	46.67	44	1.2	H	-63.84	0.15	0.00	-63.99	-13.00	-50.99
201.33	39.03	335	2.1	V	-68.56	0.15	0.00	-68.71	-13.00	-55.71
3817.50	65.95	268	1.2	H	-45.59	2.37	12.50	-35.46	-13.00	-22.46
3817.50	59.98	358	1.2	V	-49.83	2.37	12.50	-39.70	-13.00	-26.70
5726.25	53.58	200	1.7	H	-56.03	2.86	12.90	-45.99	-13.00	-32.99
5726.25	44.73	324	1.7	V	-64.15	2.86	12.90	-54.11	-13.00	-41.11

Vice board  
Cellular Band (Part 22H)

Frequency	Receiver Reading	Turn table Angle	RX Antenna		Substituted			Absolute Level	Result	
			Height	Polar	SG Level	Cable	Antenna Gain		Limit	Margin
(MHz)	(dB $\mu$ V)	Degree	(m)	(H/V)	(dBm)	(dB)	(dB)	(dBm)	(dBm)	(dB)
CDMA 800 Channel 384										
201.33	40.34	53	1.4	H	-70.17	0.15	0.00	-70.32	-13.00	-57.32
201.33	46.75	329	1.8	V	-60.84	0.15	0.00	-60.99	-13.00	-47.99
1649.40	68.43	105	1.7	H	-45.54	0.30	9.40	-36.44	-13.00	-23.44
1649.40	57.22	217	1.9	V	-56.31	0.30	9.40	-47.21	-13.00	-34.21
2474.10	54.97	273	1.1	H	-59.03	0.43	10.60	-48.86	-13.00	-35.86
2474.10	50.56	8	1.6	V	-59.72	0.43	10.60	-49.55	-13.00	-36.55

Cellular Band (Part 24E/27)

Frequency	Receiver Reading	Turn table Angle	RX Antenna		Substituted			Absolute Level	Result	
			Height	Polar	SG Level	Cable	Antenna Gain		Limit	Margin
(MHz)	(dB $\mu$ V)	Degree	(m)	(H/V)	(dBm)	(dB)	(dB)	(dBm)	(dBm)	(dB)
CDMA 1900 Channel 1175										
201.33	44.20	329	1.2	H	-66.31	0.15	0.00	-66.46	-13.00	-53.46
201.33	40.30	47	1.8	V	-67.29	0.15	0.00	-67.44	-13.00	-54.44
3760.00	65.95	320	1.7	H	-45.59	2.37	12.50	-35.46	-13.00	-22.46
3760.00	59.98	247	1.2	V	-49.83	2.37	12.50	-39.70	-13.00	-26.70
5640.00	53.58	186	2.0	H	-56.03	2.86	12.90	-45.99	-13.00	-32.99
5640.00	44.73	63	1.6	V	-64.15	2.86	12.90	-54.11	-13.00	-41.11

Note: 1) Absolute Level = SG Level - Cable loss + Antenna Gain

2) Margin = Limit- Absolute Level

## 11 Band Edge Measurement

Test Requirement:	FCC Part 2.1051,22.917(a),24.238(a)
Test Method:	TIA/EIA-603-D:2010 KDB971168 D01 v02r02
Test Mode:	Transmitting

### 11.1 EUT Operation

Operating Environment :

Temperature:	23.5 °C
Humidity:	52.3 % RH
Atmospheric Pressure:	101.3kPa

### 11.2 Test Procedure

The RF output of the transmitter was connected to the input of the spectrum analyzer through sufficient attenuation.

According to FCC Part 22.917(a), the power of any emissions outside of the authorized operating frequency ranges must be attenuated below the transmitting power (P) by a factor of at least  $43 + 10 \log(P)$  dB.

According to FCC Part 24.238(a), the power of any emissions outside of the authorized operating frequency ranges must be attenuated below the transmitting power (P) by a factor of at least  $43 + 10 \log(P)$  dB.

The center of the spectrum analyzer was set to block edge frequency

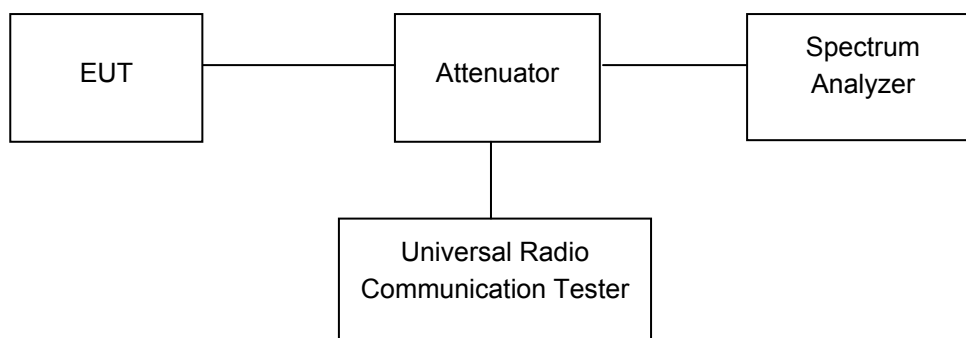

### 11.3 Test Result

Test plots  
Cellular Band (Part 22H)

Main board

CDMA 800 band edge-left side



CDMA 800 band edge-right side



Cellular Band (Part 24E)

CDMA 1900 band edge-left side

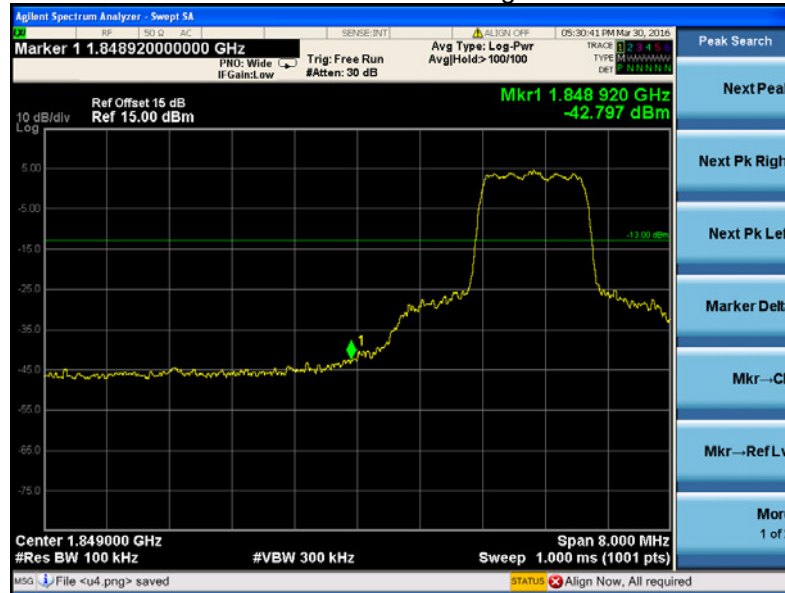

CDMA 1900 band edge-right side

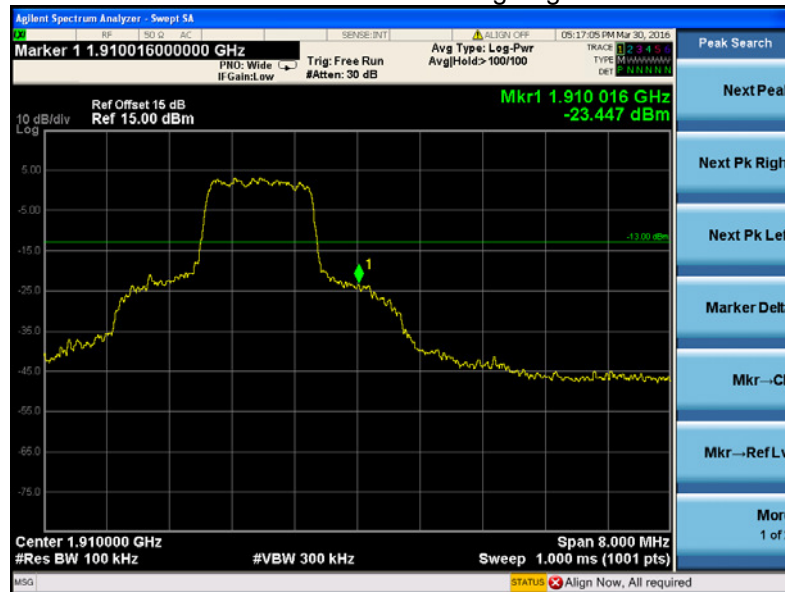

Vice board

CDMA 800 band edge-left side



CDMA 800 band edge-right side



### Cellular Band (Part 24E)

#### CDMA 1900 band edge-left side

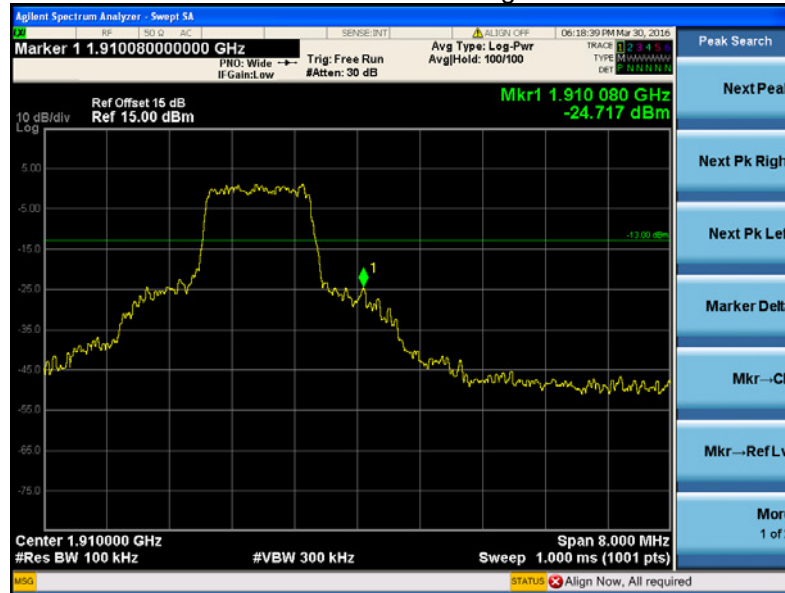

#### CDMA 1900 band edge-right side

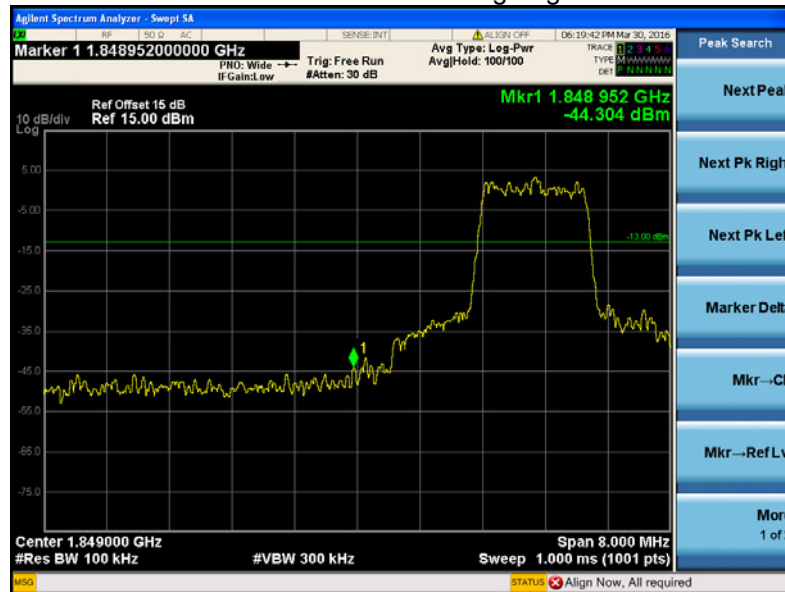



## 12 FREQUENCY STABILITY

Test Requirement:	FCC Part 2.1055,22.355,24.235,27.5(h),27.54
Test Method:	TIA/EIA-603-D:2010 KDB971168 D01 v02r02
Test Mode:	Transmitting

### 12.1 EUT Operation

Operating Environment :	
Temperature:	22.9 °C
Humidity:	52.0 % RH
Atmospheric Pressure:	101.3kPa

### 12.2 Test Procedure

Frequency Stability vs. Temperature: The equipment under test was connected to an external DC power supply and the RF output was connected to communication test set via feed-through attenuators. The EUT was placed inside the temperature chamber. The DC leads and RF output cable exited the chamber through an opening made for the purpose.

After the temperature stabilized for approximately 20 minutes, the frequency output was recorded from the communication test set.

Frequency Stability vs. Voltage: For hand carried, battery powered equipment; reduce primary supply voltage to the battery operating end point which shall be specified by the manufacturer.

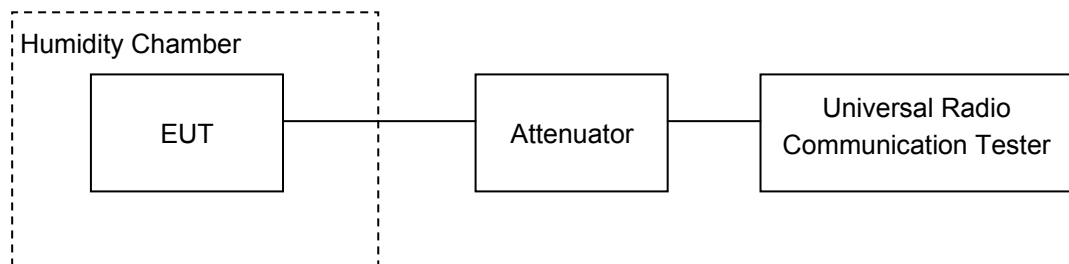

### 12.3 Test Result

Main board

Cellular Band (Part 22H)

CDMA 800 Test Frequency:836.52MHz				
Temperature (°C)	Power Supply (VDC)	Frequency Error (Hz)	Frequency Error (ppm)	Limit (ppm)
50	3.7	-5	-0.0060	2.5
40		2	0.0024	2.5
30		-7	-0.0084	2.5
20		2	0.0020	2.5
10		8	0.0096	2.5
0		2	0.0024	2.5
-10		0	0.0000	2.5
-20		-1	-0.0012	2.5
-30		-5	-0.0060	2.5
20		3.3	-4	-0.0048
20	4.2	2	0.0024	2.5

## PCS Band (Part 24E)

CDMA 1900 Test Frequency:1880.00MHz				
Temperature (°C)	Power Supply (VDC)	Frequency Error (Hz)	Frequency Error (ppm)	Limit (ppm)
50	3.7	-9	-0.0048	2.5
40		-2	-0.0011	2.5
30		-1	-0.0005	2.5
20		0	-0.0002	2.5
10		-7	-0.0037	2.5
0		-9	-0.0048	2.5
-10		-1	-0.0005	2.5
-20		-3	-0.0016	2.5
-30		-1	-0.0005	2.5
20		3.3	5	0.0027
20	4.2	6	0.0032	2.5

## Vice board

## Cellular Band (Part 22H)

CDMA 800 Test Frequency:836.52MHz				
Temperature (°C)	Power Supply (VDC)	Frequency Error (Hz)	Frequency Error (ppm)	Limit (ppm)
50	3.7	-5	-0.0060	2.5
40		9	0.0108	2.5
30		0	0.0000	2.5
20		0	-0.0003	2.5
10		6	0.0072	2.5
0		1	0.0012	2.5
-10		0	0.0000	2.5
-20		-5	-0.0060	2.5
-30		2	0.0024	2.5
20		3.3	3	0.0036
20	4.2	8	0.0096	2.5

## PCS Band (Part 24E)

CDMA 1900 Test Frequency:1880.00MHz				
Temperature (°C)	Power Supply (VDC)	Frequency Error (Hz)	Frequency Error (ppm)	Limit (ppm)
50	3.7	9	0.0048	2.5
40		-7	-0.0037	2.5
30		1	0.0005	2.5
20		0	-0.0002	2.5
10		3	0.0016	2.5
0		4	0.0021	2.5
-10		8	0.0043	2.5
-20		-3	-0.0016	2.5
-30		5	0.0027	2.5
20		3.3	-4	-0.0021
20	4.2	-9	-0.0048	2.5

